

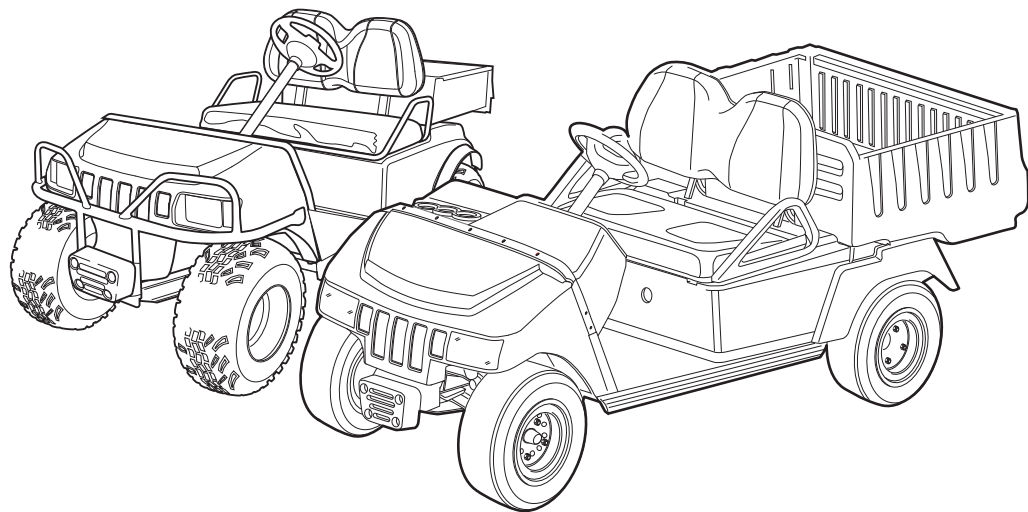

2007-2008 MAINTENANCE SERVICE MANUAL



**XRT 800, 810 and 850
GASOLINE/ELECTRIC**

MANUAL NUMBER 103209106
EDITION CODE 0907E0312D

FOREWORD

Club Car vehicles are designed and built to provide the ultimate in performance efficiency; however, proper maintenance and repair are essential for achieving maximum service life and continued safe and reliable operation.

This manual provides detailed information for the maintenance and repair of the Club Car XRT 800, 810 and 850 series vehicles, and should be thoroughly reviewed prior to servicing the vehicle. The procedures provided must be properly implemented, and the DANGER, WARNING, and CAUTION statements must be heeded.

This manual was written for the trained technician who already possesses knowledge and skills in electrical and mechanical repair. *If the technician does not have such knowledge and skills, attempted service or repairs to the vehicle may render the vehicle unsafe.* For this reason, Club Car advises that all repairs and/or service be performed by an authorized Club Car distributor/dealer representative or by a Club Car factory-trained technician.

It is the policy of Club Car to assist its distributors and dealers in continually updating their service knowledge and facilities so they can provide prompt and efficient service for vehicle owners. Regional technical representatives, vehicle service seminars, periodic service bulletins, maintenance and service manuals, and other service publications also represent Club Car's continuing commitment to customer support.

This manual covers all aspects of typical vehicle service; however, unique situations sometimes occur when servicing a vehicle. If it appears that a service question is not answered in this manual, you may write to us at: Club Car, Inc., P.O. Box 204658; Augusta, GA 30917-4658 USA, Attention: Technical Services, or contact a Club Car Technical Service Representative at (706) 863-3000, ext. 3580.

Copyright © 2007, 2008, 2012 Club Car, Inc.
Club Car and Carryall are registered
trademarks of Club Car, Inc

This manual effective August 1, 2006.

WARNING

- **Read Section 1 – Safety before attempting any service on the vehicle.**
- **Before servicing vehicle, read complete section(s) and any referenced information that may be relevant to the service or repair to be performed.**

NOTE: *This manual represents the most current information at the time of publication. Club Car is continually working to further improve its vehicles and other products. These improvements may affect servicing procedures. Any modification and/or significant change in specifications or procedures will be forwarded to all Club Car dealers and will, when applicable, appear in future editions of this manual.*

Club Car reserves the right to change specifications and designs at any time without notice and without the obligation of making changes to units previously sold.

There are no warranties expressed or implied in this manual. See the limited warranty found in the vehicle Owner's Manual.

CONTENTS

SECTION 1 – SAFETY

General Warning	1-1
-----------------------	-----

SECTION 2 – VEHICLE SPECIFICATIONS

800 and 810 Specifications	2-1
850 Specifications	2-3

SECTION 3 – GENERAL INFORMATION

Serial Number Identification	3-1
Storage – Gasoline Vehicle	3-2
Preparing the Gasoline Vehicle for Extended Storage	3-2
Returning the Stored Gasoline Vehicle to Service	3-4
Storage – Electric Vehicle	3-4
Preparing the Electric Vehicle for Extended Storage	3-5
Returning the Stored Electric Vehicle to Service	3-5

SECTION 4 – BODY AND TRIM

Cleaning the Vehicle	4-1
Seat Cleaning	4-1
Front and Rear Body Repair	4-2
Minor Scratches and Surface Blemishes	4-2
Small Scratches That Cannot Be Buffed Out	4-2
Gouges, Punctures, Tears, Large Scratches, and Abrasions	4-2
Front Body – 800 and 810	4-3
Bumper/Brush Guard Removal	4-3
Bumper/Brush Guard Installation	4-3
Front Body Removal	4-3
Molded Dash Removal	4-4
Molded Dash Installation	4-4
Front Body Installation	4-4

Front Body – 850	4-5
Bumper/Brush Guard (Standard) Removal	4-5
Bumper/Brush Guard (Standard) Installation	4-6
Bumper/Brush Guard (Heavy Duty) Removal	4-7
Bumper/Brush Guard (Heavy Duty) Installation	4-7
Front Removal	4-7
Front Body Installation	4-7
Cargo Bed – 800 and 810	4-8
Cargo Bed Removal	4-8
Cargo Bed Installation	4-9
Bed Latch Assembly	4-9
Bed Latch Assembly Installation	4-11
Seat Back Support Brackets – 800 and 810	4-11
Seat Back Support Bracket Removal	4-11
Seat Back Support Bracket Installation	4-12
Rear Body and Fenders – 800 and 810	4-12
Rear Body Removal	4-12
Rear Fender Removal	4-14
Rear Fender Installation	4-14
Rear Body Installation	4-15
Rear Body – 850	4-15
Rear Body Removal	4-15
Rear Body Installation	4-19
Floor Mat	4-19
Floor Mat Removal	4-19
Floor Mat Installation	4-19

SECTION 5 – ACCELERATOR AND BRAKE PEDAL GROUP

Brake Pedal and Park Brake	5-1
Brake Pedal Removal	5-1
Brake Pedal Installation	5-2
Park Brake Removal	5-3
Park Brake Installation	5-4
Accelerator Pedal – Gasoline Vehicles	5-5
Accelerator Pedal Removal	5-5
Accelerator Pedal Installation	5-7
Accelerator Pedal – Electric Vehicles	5-8
Accelerator Pedal Removal	5-8
Accelerator Pedal Installation	5-10
Pedal Group Adjustment – Gasoline Vehicle	5-11
Pedal Group Adjustment – Electric Vehicles	5-16

SECTION 6 – WHEEL BRAKE ASSEMBLIES

Brake Shoe Removal	6-1
Brake Assembly Cleaning	6-5
Brake Shoe Installation	6-6
Brake Adjustment	6-8
Brake Cluster Removal and Installation	6-8
Brake Cluster Installation	6-9
Brake Cable Removal and Installation	6-10

SECTION 7 – STEERING AND FRONT SUSPENSION

General Information	7-1
Steering Wheel	7-1
Steering Wheel Removal	7-1
Steering Wheel Installation	7-2
Steering Column	7-2
Steering Column Removal	7-2
Steering Column Disassembly	7-4
Steering Column Assembly	7-4
Steering Column Installation	7-5
Steering Adjustment	7-6
Rack and Pinion	7-7
Rack and Pinion Removal	7-7
Rack and Pinion Disassembly	7-7
Rack and Pinion Assembly	7-10
Rack and Pinion Installation	7-12
Tie Rod and Drag Link	7-12
Tie Rod and Drag Link Removal	7-12
Tie Rod and Drag Link Installation	7-12
Front Suspension	7-13
Lubrication	7-13
Wheel Alignment	7-13
Front Suspension Components	7-15
Tapered Leaf Spring Removal	7-15
Tapered Leaf Spring Installation	7-15
Kingpin and Steering Spindle Removal	7-16
Kingpin and Steering Spindle Installation	7-16
Delta A-Plate Removal	7-16
Delta A-Plate Installation	7-19
Shock Absorber Removal	7-19
Shock Absorber Installation	7-19

Front Wheel Bearings and Hubs	7-19
Front Wheel Free Play Inspection	7-19
Front Hub Removal	7-19
Front Hub Installation	7-20

SECTION 8 – WHEELS AND TIRES

General Information	8-1
Wheels	8-1
Wheel Removal	8-1
Wheel Installation	8-1
Tires	8-1
Tire Removal	8-1
Tire Repair	8-2
Tire Installation	8-3

SECTION 9 – REAR SUSPENSION

General Information	9-1
Shock Absorbers	9-1
Shock Absorber Removal and Inspection	9-1
Shock Absorber Installation	9-1
Leaf Springs	9-2
Leaf Spring Removal – 800 and 810	9-2
Leaf Spring Removal – 850	9-4
Leaf Spring Installation – All Vehicles	9-4
Stabilizer Bar Removal	9-7
Stabilizer Bar Installation	9-7

SECTION 10 – PERIODIC MAINTENANCE

General Information	10-1
Periodic Service Schedules	10-1
Periodic Lubrication Schedules	10-4
Engine Oil – Gasoline Vehicles	10-6
Engine Oil Level Check	10-6
Engine Oil And Filter Change	10-7
Oil Viscosity	10-9

SECTION 11 – TROUBLESHOOTING AND ELECTRICAL SYSTEM: 800 AND 810 GAS

General Information	11-1
Troubleshooting Guide	11-1

Electrical System	11-5
Lockout Cam	11-5
Wiring Diagrams	11-6
Test Procedures	11-8
Index of Test Procedures	11-8

SECTION 12 – TROUBLESHOOTING AND ELECTRICAL SYSTEM: 850 GAS

General Information	12-1
Troubleshooting Guide	12-1
Wiring Diagram	12-6
Electrical System	12-8
Test Procedures	12-8
Index of Test Procedures	12-8

SECTION 13 – ELECTRICAL COMPONENTS: 800 AND 810 GASOLINE VEHICLES

Starter/Generator	13-1
Voltage Regulator	13-11
Diode	13-12
Key Switch	13-14
Solenoid	13-15
Fuse	13-16
Lockout Cam Limit Switch	13-17
Lockout Cam	13-18
Reverse Warning Buzzer	13-19
Reverse Buzzer Limit Switch	13-20
Oil Warning Light	13-20
Fuel Gauge/Hour Meter	13-21
Fuel Level Sending Unit	13-22
RPM Limiter	13-23
Ignition Coil	13-24
Oil Level Sensor	13-27
Headlights	13-27
Voltage Limiter	13-28
Light Switch	13-29
Battery	13-30
Ground Cables	13-34

SECTION 14 – ELECTRICAL COMPONENTS: 850 GASOLINE VEHICLE

Starter/Generator	14-1
Voltage Regulator	14-11

Key Switch	14-12
Solenoid	14-14
Fuse	14-14
Kill Limit Switch	14-15
Neutral Lockout Limit Switch	14-16
Reverse Warning Buzzer	14-18
Reverse Buzzer Limit Switch	14-19
Low Oil Warning Light	14-20
Fuel Gauge/Hour Meter	14-21
Fuel Level Sending Unit	14-22
RPM Limiter	14-22
Ignition Coil	14-23
Oil Level Sensor	14-26
Headlights	14-26
Voltage Limiter	14-28
Headlight Switch	14-29
Battery	14-30
Ground Cables	14-34

SECTION 15 – ENGINE

General Information	15-1
Before Servicing	15-1
Engine Rotation	15-1
Spark Plug	15-1
Cylinder Head	15-3
General Information	15-3
Breather Valve (Reed Valve)	15-3
Crankcase	15-3
Engine Removal	15-3
Crankcase Cover Removal	15-3
Oil Level Sensor	15-5
Crankcase Cover Installation	15-5
Ignition Coil and Flywheel	15-6
Flywheel Installation	15-8
Engine Installation	15-9
Torque Specifications	15-10
Adjustments and Settings	15-10

SECTION 16 – FUEL SYSTEM: GASOLINE VEHICLE

General Information	16-1
---------------------------	------

Carburetor	16-1
Main Jet Elevation/Size Chart	16-3
Changing the Main Jet	16-3
Engine Control Linkage	16-6
General Information	16-6
Accelerator Rod	16-7
Governor Cable	16-9
Accelerator Cable	16-10
Closed Throttle or Idle Adjustment	16-11
Engine RPM Adjustment	16-12
Choke and Air Intake System	16-12
Choke Button Removal	16-12
Choke Button Installation	16-12
Air Box Removal	16-13
Air Box Installation	16-13
Intake Duct Removal	16-13
Intake Duct Installation	16-14
Air Filter	16-16
Fuel Filters	16-17
Fuel Filter Removal	16-17
Fuel Filter Installation	16-17
Fuel Pump	16-19
General Information	16-19
Fuel Pump Removal	16-19
Fuel Pump Disassembly	16-19
Fuel Pump Cleaning and Inspection	16-20
Fuel Pump Assembly	16-20
Fuel Pump Installation	16-21
Fuel Tank	16-21
General Information	16-21
Fuel Tank Removal	16-22
Fuel Tank Disposal	16-23
Fuel Tank Storage	16-23
Fuel Tank Installation	16-23
Fuel Lines	16-25
Fuel Shut-Off Valve	16-25
Fueling Instructions	16-26

SECTION 17 – EXHAUST SYSTEM: GASOLINE VEHICLES

Muffler	17-1
Muffler Removal	17-1
Muffler Installation	17-1

SECTION 18 – UNITIZED TRANSAXLE: 800/810 GASOLINE VEHICLES

General Information	18-1
Lubrication	18-2
Axle Shaft	18-2
Axle Shaft and Oil Seal Removal	18-2
Axle Bearing	18-3
Axle Shaft Installation	18-5
Unitized Transaxle Removal	18-6
Unitized Transaxle Installation	18-13
Forward/Reverse Shifter Cable	18-19
Forward/Reverse Shifter Cable Removal	18-19
Forward/Reverse Shifter Cable Installation	18-19
Forward/Reverse Shifter Cable Adjustment	18-20

SECTION 19 – UNITIZED TRANSAXLE: 850 GASOLINE VEHICLE

General Information	19-1
Lubrication	19-2
Axle Shaft	19-2
Axle Shaft and Oil Seal Removal	19-2
Axle Bearing	19-3
Axle Shaft Installation	19-5
Unitized Transaxle Removal	19-6
Unitized Transaxle Installation	19-14
Forward/Reverse Shifter Cable	19-19
Forward/Reverse Shifter Cable Removal	19-19
Forward/Reverse Shifter Cable Installation	19-19
Forward/Reverse Shifter Cable Adjustment	19-21

SECTION 20 – TORQUE CONVERTER: GASOLINE VEHICLE

General Information	20-1
Troubleshooting	20-1
Drive Belt	20-2
Drive Belt Removal	20-2
Drive Belt Installation	20-3

Drive Clutch	20-4
Drive Clutch Removal	20-4
Drive Clutch Cleaning and Inspection	20-5
Drive Clutch Disassembly	20-7
Inspection of Drive Clutch Parts	20-9
Drive Clutch Assembly	20-10
Drive Clutch Installation	20-12
Driven Clutch	20-12
Driven Clutch Removal	20-12
Driven Clutch Disassembly	20-12
Driven Clutch Inspection	20-13
Driven Clutch Assembly	20-13
Driven Clutch Installation	20-16

SECTION 21 – ELECTRICAL SYSTEM AND TESTING: ELECTRIC VEHICLE

General Information	21-1
Wiring Diagram	21-2
Troubleshooting	21-4
Troubleshooting the Vehicle with the Diagnostic Handset	21-4
Troubleshooting Guide 1	21-5
Troubleshooting Guide 2	21-8
Test Procedures	21-10
Index of Test Procedures	21-10
Communication Display Module (CDM)	21-33
Using the CDM to Retrieve Data from the Onboard Computer	21-34
CDM Troubleshooting Guide	21-35

SECTION 22 – IQ DISPLAY MODULE (IQDM) AND IQDM-P DIAGNOSTICS

Plugging the Handset into the Vehicle	22-1
Introductory Display	22-2
Menu Navigation	22-2
Monitor Menu	22-4
Faults Menu	22-6
Functions Menu	22-11
Get Settings From Controller	22-11
Write Settings to Controller	22-12
Reset All Settings	22-13
Information	22-14

Programmer Setup	22-14
Program	22-14
Faults	22-14
Information	22-15
IQDM and IQDM-P Handset Troubleshooting	22-16
Test Procedures	22-17
Index of Test Procedures	22-17

SECTION 23 – ELECTRICAL COMPONENTS: ELECTRIC VEHICLE

Key Switch – 800 and 810	23-1
Key Switch – 850	23-2
Forward/Reverse Switch – 800 and 810	23-4
Forward/Reverse Rocker Switch – 850	23-6
Tow/Run Switch	23-7
Motor Controller Output Regulator (MCOR)	23-8
Reverse Buzzer	23-9
Solenoid	23-10
Onboard Computer (OBC)	23-11
Solid State Speed Controller	23-13
Charger Receptacle	23-15
Receptacle Fuse Link	23-16
Battery Warning Light	23-17

SECTION 24 – BATTERIES: ELECTRIC VEHICLES

General Information	24-1
Battery Troubleshooting Chart	24-2
Battery Testing	24-3
Battery Charger Test	24-3
On-Charge Voltage Test	24-3
Hydrometer Test	24-3
Discharge Test	24-5
Battery Troubleshooting Examples	24-7
Battery Replacement	24-8
Battery Care	24-9
Preventive Maintenance	24-9
Self-Discharge	24-10
Electrolyte Level	24-10
Mineral Content	24-11
Vibration Damage	24-11

Battery Charger	24-12
Charging Batteries	24-12
Plug and Receptacle	24-13
Receptacle Fuse Link	24-14
Charger Shuts Off After 16 Hours	24-14
Deep-Discharge	24-14
Early Excessive Discharging	24-15
Incoming AC Service	24-15
Fleet Rotation	24-15
Numbering Vehicles and Chargers	24-15
Battery Storage	24-15
Charging a Battery Pack that has Low Voltage	24-16

SECTION 25 – BATTERY CHARGER: ELECTRIC VEHICLE

Refer to the appropriate Battery Charger Maintenance and Service Manual.

SECTION 26 – MOTOR (MODEL 5BC59JBS6390)

General Information	26-1
Motor Identification	26-1
External Motor Testing	26-1
Motor	26-2
Motor Component Testing and Inspection	26-5
Armature	26-5
Field Windings Inspection	26-6
Motor Components	26-6
Bearing Inspection	26-7
Bearing Removal	26-7
Bearing Installation	26-7
Speed Sensor Magnet Inspection	26-9
Speed Sensor Magnet Removal	26-9
Speed Sensor Magnet Installation	26-9
Reconditioning the Motor	26-9
Motor Assembly	26-10
Motor Installation	26-12
Motor Speed Sensor	26-15

SECTION 27 – MOTOR (MODEL EJ4-4001)

General Information	27-1
Motor Identification	27-1
External Motor Testing	27-1

Motor	27-2
Motor Removal	27-2
Motor Disassembly	27-4
Motor Component Testing and Inspection	27-6
Armature Inspection and Testing	27-6
Motor Frame and Field Windings Inspection	27-7
Motor Brush, Spring, and Terminal Insulator Inspection	27-8
Reconditioning the Motor	27-11
Motor Assembly	27-11
Motor Installation	27-13

SECTION 28 – TRANSAXLE (TYPE G): ELECTRIC VEHICLE

Transaxle Identification	28-1
Lubrication	28-1
Axle Bearing and Shaft	28-1
Axle Shaft	28-1
Axle Bearing	28-4
Transaxle	28-5
Transaxle Removal	28-5
Transaxle Disassembly, Inspection, and Assembly	28-7
Transaxle Disassembly and Inspection	28-7
Transaxle Assembly	28-9
Transaxle Installation	28-10

SECTION 29 – IQ DISPLAY MODULE (IQDM-P) PROGRAMMING

Plugging the Handset into the Vehicle	29-1
Program Menu	29-2
Speed Setting	29-2
Fast Accel	29-3
Pedal Up Mode	29-3
Speed Cal	29-3
Code A, Code B, and Code C	29-3

SECTION i – INDEX

SECTION 1 – SAFETY

To ensure the safety of those servicing these vehicles, and to protect the vehicles from possible damage resulting from improper service or maintenance, the procedures in this manual must be followed.

It is important to note that throughout this manual there are statements labeled DANGER, WARNING, or CAUTION. These special statements relate to specific safety issues, and must be read, understood, and heeded before proceeding with procedures. There are statements labeled NOTE, which provide other essential service or maintenance information.

⚠ DANGER

- A DANGER indicates an immediate hazard that will result in severe personal injury or death.

⚠ WARNING

- A WARNING indicates an immediate hazard that could result in severe personal injury or death.

⚠ CAUTION

- A CAUTION with the safety alert symbol indicates a hazard or unsafe practice that could result in minor personal injury.

CAUTION

- A CAUTION without the safety alert symbol indicates a potentially hazardous situation that could result in property damage.

GENERAL WARNING

The following safety statements must be heeded whenever the vehicle is being operated, repaired, or serviced. Service technicians should become familiar with these general safety statements. Also, other specific safety statements appear throughout this manual and on the vehicle.

⚠ DANGER

- **Battery – Explosive gases! Do not smoke. Keep sparks and flames away from the vehicle and service area. Ventilate when charging or operating vehicle in an enclosed area. Wear a full face shield and rubber gloves when working on or near batteries.**
- **Battery – Poison! Contains acid! Causes severe burns. Avoid contact with skin, eyes, or clothing. Antidotes:**
 - **External: Flush with water. Call a physician immediately.**
 - **Internal: Drink large quantities of milk or water. Follow with milk of magnesia or vegetable oil. Call a physician immediately.**
 - **Eyes: Flush with water for 15 minutes. Call a physician immediately.**
- **Gasoline – Flammable! Explosive! Do not smoke. Keep sparks and flames away from the vehicle and service area. Service only in a well-ventilated area.**
- **Do not operate gasoline vehicle in an enclosed area without proper ventilation. The engine produces carbon monoxide, which is an odorless, deadly poison.**

 WARNING

- Follow the procedures exactly as stated in this manual, and heed all **DANGER**, **WARNING**, and **CAUTION** statements in this manual as well as those on the vehicle.
- Only trained technicians should service or repair the vehicle. Anyone doing even simple repairs or service should have knowledge and experience in electrical and mechanical repair. The appropriate instructions must be used when performing maintenance, service, or accessory installation.
- Prior to servicing the vehicle or leaving the vehicle unattended, turn the key switch **OFF**, remove the key, and place the Forward/Reverse handle in the **NEUTRAL** position. Chock the wheels when servicing the vehicle.

Gasoline vehicles only:

- To avoid unintentionally starting the vehicle:
 - Disconnect battery cables, negative (–) cable first (Figure 1-1, Page 1-3).
 - Disconnect the spark plug wire from the spark plug.
- Frame ground – Do not allow tools or other metal objects to contact frame when disconnecting battery cables or other electrical wiring. Do not allow a positive wire to touch the vehicle frame, engine, or any other metal component.

Electric vehicles only:

- Place Tow/Run switch in the **TOW** position before disconnecting or connecting the batteries.
- To avoid unintentionally starting the vehicle, disconnect the batteries as shown (Figure 1-2, Page 1-3).
- After disconnecting the batteries, wait 90 seconds for the controller capacitors to discharge.

All vehicles:

- Wear safety glasses or approved eye protection when servicing the vehicle or battery charger. Wear a full face shield and rubber gloves when working on or near batteries.
- Do not wear loose clothing or jewelry such as rings, watches, chains, etc., when servicing the vehicle.
- Moving parts! Do not attempt to service the vehicle while it is running.
- Hot! Do not attempt to service hot engine or exhaust system. Failure to heed this warning could result in severe burns.
- Use insulated tools when working near batteries or electrical connections. Use extreme caution to avoid shorting of components or wiring.
- Check the vehicle owner's manual for proper location of all vehicle safety and operation decals and make sure they are in place and are easy to read.
- Any modification or change to the vehicle that affects the stability or handling of the vehicle, or increases maximum vehicle speed beyond factory specifications, could result in severe personal injury or death.
- Lift only one end of the vehicle at a time. Use a suitable lifting device (chain hoist or hydraulic floor jack) with 1000 lb. (454 kg) minimum lifting capacity. Do not use lifting device to hold vehicle in raised position. Use approved jack stands of proper weight capacity to support the vehicle and chock the wheels that remain on the floor. When not performing a test or service procedure that requires movement of the wheels, lock the brakes.
- If wires are removed or replaced, make sure wiring and wire harness are properly routed and secured. Failure to properly route and secure wiring could result in vehicle malfunction, property damage, personal injury, or death.

WARNING CONTINUED ON NEXT PAGE...

⚠ WARNING

- For vehicles with cargo beds, remove all cargo before raising the bed or servicing the vehicle. If the vehicle is equipped with a prop rod, ensure that it is securely engaged while bed is raised. Do not close bed until all persons are clear of cargo bed area. Keep hands clear of all crush areas. Do not drop cargo bed; lower gently and keep entire body clear. Failure to heed this warning could result in severe personal injury or death.
- Improper use of the vehicle or failure to properly maintain it could result in decreased vehicle performance, severe personal injury, or death.
- Do not leave children unattended on vehicle.

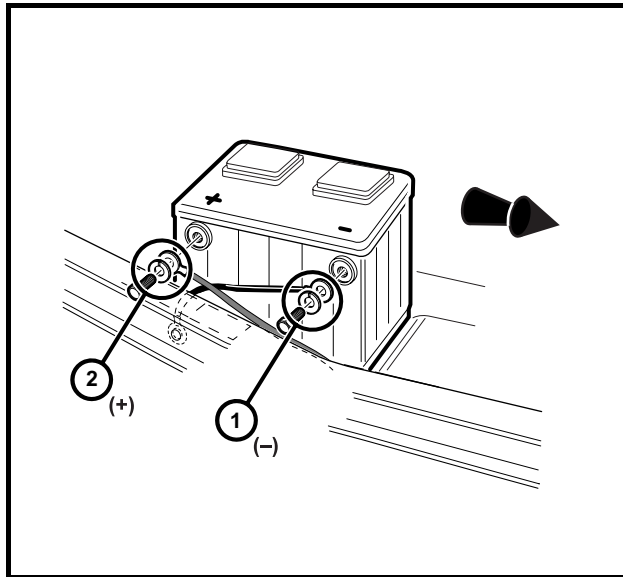

Figure 1-1 Gasoline Vehicle

(Viewed from passenger side of vehicle)
 1. Remove negative battery cable.
 2. Remove positive battery cable.
 Connect battery cables in reverse order.

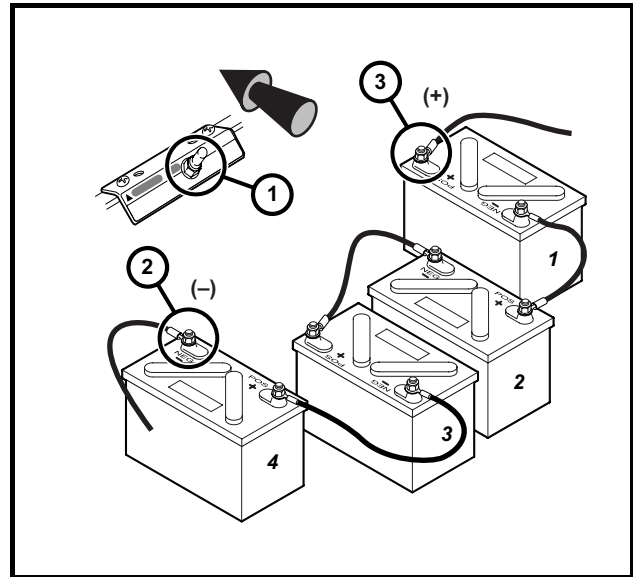

Figure 1-2 IQ System Electric Vehicle

(Viewed from driver side of vehicle)
 1. Place TOW/RUN Switch in TOW before disconnecting or connecting battery cables.
 2. Remove negative battery cable.
 3. Remove positive battery cable.
 Connect battery cables in reverse order.

SECTION 2 – VEHICLE SPECIFICATIONS

800 AND 810 SPECIFICATIONS

SPECIFICATIONS	Electric XRT 800-E	Electric XRT 810-E	Gasoline XRT 800	Gasoline XRT 810
POWER SOURCE				
Drive motor: Direct drive, 48 volts DC, shunt-wound, 3.2 hp	•			
Engine: 4-cycle OHV, 286 cc, 9.5 maximum hp@ 3600 RPM (per SAE J 1940/1349), single-cylinder, air-cooled, with pressure lubrication system			•	
Engine: 4-cycle OHV, 351cc, 11.5 maximum hp@ 3600 RPM (per SAE J 1940/1349), single-cylinder, air-cooled, with pressure lubrication system				•
Fuel system: Side-draft carburetor with float bowl, fixed jets, fuel filters, and impulse fuel pump			•	
Governor: Automatic ground-speed sensing, internally geared in unitized transaxle			•	
Ignition: Transistor electronic ignition with electronic RPM limiter			•	
Transaxle: Double reduction helical gear with 12.3:1 direct drive axle	•			
Unitized transaxle: Fully synchronized forward and reverse with neutral and reduced speed reverse (11.8:1 forward, 17.1:1 reverse)			•	
Torque converter: Automatic, variable-speed, dry type			•	
Electrical system: 48 volts DC, reduced speed reverse	•			
Electrical system: 12 volt, 500 cca at 0 °F (-17.8 °C), 650 at 32 °F (0 °C). 105-minute reserve capacity and 35-amp charging capacity			•	
Batteries: High capacity, deep cycle, Trojan PowerDrive 12-volt	•			
Charger: Automatic, 48-volt; UL and CSA listed	•			
STEERING/SUSPENSION/BRAKES				
Steering: Self-adjusting rack and pinion			•	
Suspension: Front and rear tapered mono-leaf springs with dual hydraulic shocks			•	
Brakes: Dual rear wheel self-adjusting brakes with cast iron drums and single brake pedal with automatic-release park brake			•	
BODY/CHASSIS				
Frame/Chassis: Twin I-Beam welded aluminum			•	
Front body: ABS			•	
Rear body: TPO			•	
Tires: 20 x 10.0 – 8 tubeless, 4 ply rated			•	
DIMENSIONS/WEIGHT				
Overall length	100.2 inches (2545 mm)			
Overall width	45 inches (1143 mm)			
Overall height (at steering wheel)	46.9 inches (1191 mm)			
Wheelbase	66.5 inches (1689 mm)			
Ground clearance	5.5 inches (140 mm)			
Front wheel tread	34.5 in (88 cm)			
Rear wheel tread	38.5 in. (98 cm)			
Weight: (without batteries)	874 lb. (396 kg)	889 lb. (403 kg)		
Vehicle Specifications continued on next page...				

SPECIFICATIONS	Electric XRT 800-E	Electric XRT 810-E	Gasoline XRT 800	Gasoline XRT 810
Weight: (dry, without battery)			781 lb. (354 kg)	805 lb. (365 kg)
Vehicle rated capacity: Level surface only	800 lb. (363 kg)			
Forward speed	17 mph (27 km)			
Standard seating capacity	2			
Liquid Capacities				
Transaxle	22 oz. (0.67 L)			
Engine crankcase (without filter)			32 oz. (0.95 L)	
Engine crankcase (with filter)			38 oz. (1.12 L)	
Unitized transaxle			27 oz. (0.8 L)	
Fuel tank			7 gallons (26.5 L)	
Tire Pressure				
Front and rear	18-20 psi (1.24-1.38 Bars)		18-20 psi (1.24-1.38 Bars)	

850 SPECIFICATIONS

SPECIFICATIONS	Electric XRT 850-E	Gasoline XRT 850
POWER SOURCE		
Drive motor: Direct drive, 48 volts DC, shunt-wound, 3.2 hp	•	
Engine: 4-cycle OHV, 351cc, 11.5 maximum hp @ 3600 RPM (per SAE J 1940/1349), single-cylinder, air-cooled, with pressure lubrication system		•
Fuel system: Side-draft carburetor with float bowl, fixed jets, fuel filters, and impulse fuel pump		•
Governor: Automatic ground-speed sensing, internally geared in unitized transaxle		•
Ignition: Transistor electronic ignition with electronic RPM limiter		•
Transaxle: Double reduction helical gear with 12.3:1 direct drive axle	•	
Unitized transaxle: Fully synchronized forward and reverse with neutral and reduced speed reverse (11.8:1 forward, 17.1:1 reverse)		•
Torque converter: Automatic, variable-speed, dry type		•
Electrical system: 48 volts DC, reduced speed reverse	•	
Electrical system: 12 volt, 500 cca at 0 °F (-17.8 °C), 650 at 32 °F (0 °C). 105-minute reserve capacity and 35-amp charging capacity		•
Batteries: High capacity, deep cycle	•	
Charger: Automatic, 48-volt; UL and CSA listed	•	
STEERING/SUSPENSION/BRAKES		
Steering: Self-adjusting rack and pinion		•
Suspension: Front and rear tapered mono-leaf springs with dual hydraulic shocks		•
Brakes: Dual rear wheel self-adjusting brakes with cast iron drums and single brake pedal with automatic-release park brake		•
BODY/CHASSIS		
Frame/Chassis: Twin I-Beam welded aluminum		•
Front body: ABS		•
Rear body: TPO		•
Tires: 22 x 11.0 – 10 tubeless, 6ply rated		•
DIMENSIONS/WEIGHT		
Overall length	110.1 inches (280 cm)	
Overall width	50.8 inches (129 cm)	
Overall height (at steering wheel)	51.8 inches (132 cm)	
Overall height (with canopy installed)	81.3 inches (207 cm)	
Wheelbase	67.3 inches (171 cm)	
Ground clearance	6.3 inches (16 cm)	
Front wheel tread	39.3 in (100 cm)	
Rear wheel tread	40.9 in. (104 cm)	
Weight (without batteries)	1022 lb. (464 kg)	
Weight (dry, without battery)		938 lb. (425 kg)
Vehicle rated capacity: Level surface only	800 lb. (363 kg)	
Forward speed	16 mph (26 km/h)	
Standard seating capacity	2/4	
Vehicle Specifications continued on next page...		

SPECIFICATIONS	Electric XRT 850-E	Gasoline XRT 850
LIQUID CAPACITIES		
Transaxle	22 oz. (0.67 L)	
Engine crankcase (without filter)		32 oz. (0.95 L)
Engine crankcase (with filter)		38 oz. (1.12 L)
Unitized transaxle		27 oz. (0.8 L)
Fuel tank		7 gallons (26.5 L)
TIRE PRESSURE		
Front and rear	14-16 psi (0.97-1.10 Bars)	

SECTION 3 – GENERAL INFORMATION

⚠ DANGER

- See General Warning on page 1-1.

⚠ WARNING

- See General Warning on page 1-1.

Important features unique to the different models covered in this manual are highlighted. It is recommended that the owner/operator read and understand this manual and pay special attention to features specific to their vehicle(s).

Refer to the owner's manual provided with the vehicle for information on the following topics:

- Controls and Indicators
- Pre-Operation and Daily Safety Checklist
- Driving Instructions
- Towing
- Transporting on a Trailer
- Subsequent Owner Registration
- Warranties

SERIAL NUMBER IDENTIFICATION

The serial number of the vehicle is printed on a bar code decal mounted on the frame, directly above the accelerator pedal (Example: XH0601-583947) (**Figure 3-1, Page 3-1**). There is also a second serial number decal mounted on the front frame behind the dash. The dash must be removed to view this decal.

NOTE: Have the vehicle serial number available when ordering parts or making inquiries.



Figure 3-1 Serial Number Decal

STORAGE – GASOLINE VEHICLE

See General Warning on page 1-1.

DANGER

- Do not attempt to drain fuel when the engine is hot or while it is running.
- Be sure to clean up any spilled gasoline before operating the vehicle.
- Store fuel in an approved fuel container only. Store in a well-ventilated area away from sparks, open flames, heaters, or heat sources.
- Keep fuel out of the reach of children.
- Do not siphon fuel from the vehicle.

WARNING

- Only trained technicians should service or repair the vehicle or battery charger. Anyone doing even simple repairs or service should have knowledge and experience in electrical and mechanical repair. The appropriate instructions must be used when performing maintenance, service, or accessory installation.
- Turn the key switch to the OFF position, remove the key, and leave the Forward/Reverse handle in the NEUTRAL position during storage. This is to prevent unintentionally starting the vehicle or a fire hazard.
- Turn the fuel shut-off valve to the closed (OFF) position (Figure 3-3, Page 3-4 or Figure 3-4, Page 3-4).

CAUTION

- Batteries in a low state of charge will freeze at low temperatures.

PREPARING THE GASOLINE VEHICLE FOR EXTENDED STORAGE

1. Store vehicle in a cool, dry place. This will minimize battery self-discharge. If the battery appears to be weak, have it charged by a trained technician. Use an automotive-type 12-volt battery charger rated at 10 amps or less.
2. Drain carburetor and seal the fuel tank.
 - 2.1. **XRT 800/810:** Place the Forward/Reverse handle in the NEUTRAL position. Turn the fuel shut-off valve (1) to the closed (OFF) position (**Figure 3-3, Page 3-4 or Figure 3-4, Page 3-4**) and run the engine until fuel remaining in the carburetor and fuel lines is depleted and the engine stalls.
 - 2.2. **XRT 850:** Place the Forward/Reverse handle in the NEUTRAL position and the neutral lockout switch in the MAINTENANCE position. Turn the fuel shut-off valve (1) to the closed (OFF) position (**Figure 3-3, Page 3-4 or Figure 3-4, Page 3-4**) and run the engine until fuel remaining in the carburetor and fuel lines is depleted and the engine stalls. Return the neutral lockout switch in the OPERATE position.
 - 2.3. Loosen, but do not remove, the carburetor drain screw and drain fuel remaining in bowl into a small, clean container, then pour the fuel from the container into vehicle fuel tank. Tighten the carburetor drain screw.
 - 2.4. Disconnect fuel vent line from fuel tank vent nipple.
 - 2.5. Plug the fuel tank vent nipple so that it is air tight. We recommend using a slip-on vinyl cap.

3. Disconnect the battery cables, negative (–) cable first. **See WARNING “To avoid unintentionally starting...” in General Warning on page 1-2.**
4. Batteries should be clean and free of corrosion. Wash tops and terminals of batteries with a solution of baking soda and water (237 mL (1 cup) baking soda per 3.8 L (1 gallon) of water). Rinse solution off batteries. Do not allow this solution to enter the batteries. Be sure terminals are tight. Let the terminals dry and then coat them with Battery Terminal Protector Spray.
5. To protect the engine, remove spark plug and pour 14.2 mL (1/2 oz.) of SAE 10 weight oil into the engine through the spark plug hole. Rotate engine crankshaft by hand several times, then install the spark plug and tighten to 27 N·m (20 ft-lb).
6. Adjust tires to recommended tire pressure. **See Section 2 – Vehicle Specifications.**
7. Perform semiannual periodic lubrication. **See Periodic Lubrication Schedules on page 10-4.**
8. Thoroughly clean front body, rear body, seats, engine compartment, and underside of vehicle.
9. Do not engage the park brake. Chock the wheels to prevent the vehicle from rolling.

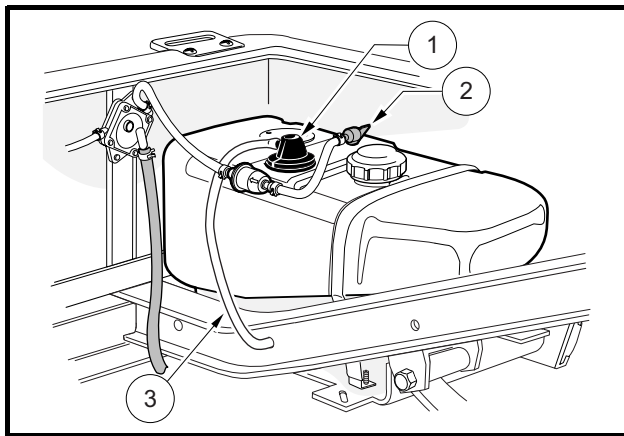
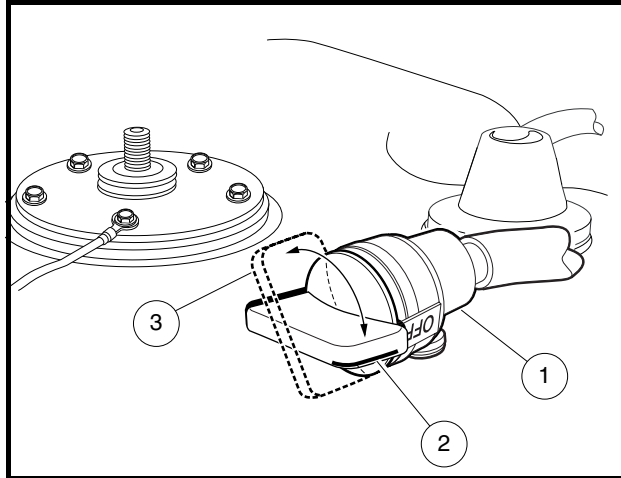

Figure 3-2 Fuel Tank, Vent, and Lines

1. Vent 2. Shut-off Valve 3. Vent Tubes



**Figure 3-3 Fuel Shut-off Valve –
49-State Fuel Tank Shown**

1. Fuel Shut-off Valve 2. Closed (OFF) 3. Open (ON)
NOTE: When selecting valve position, ensure that it is fully opened or fully closed.

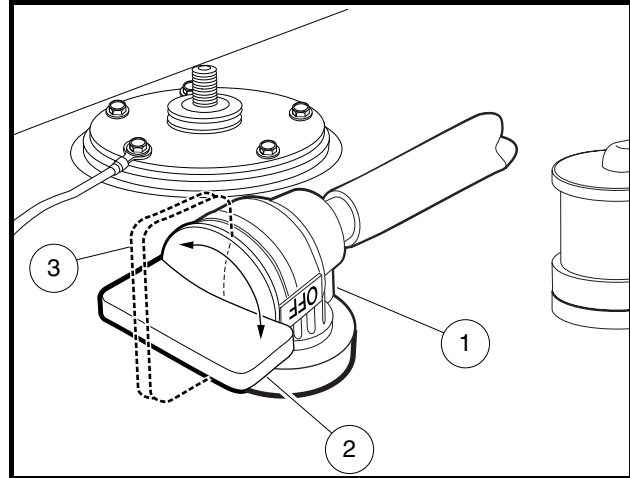

**Figure 3-4 Fuel Shut-off Valve –
California Fuel Tank Shown**

1. Fuel Shut-off Valve 2. Closed (OFF) 3. Open (ON)
NOTE: When selecting valve position, ensure that it is fully opened or fully closed.

RETURNING THE STORED GASOLINE VEHICLE TO SERVICE

1. Restore fuel system to operation (**Figure 3-2, Page 3**).
 - 1.1. Remove plug from fuel tank vent.
 - 1.2. Connect vent tube to fuel tank vent.
2. Connect battery cables, positive (+) cable first, and tighten terminals to 16 N·m (12 ft·lb).
3. Completely open the fuel shut-off valve (**Figure 3-3, Page 3-4** or **Figure 3-4, Page 3-4**). Make sure the valve is fully open. A partially closed fuel shut-off valve combined with the use of the choke can result in a fouled spark plug and engine failure.
4. **XRT 800/810:** Place the Forward/Reverse handle in the NEUTRAL position. Crank the engine until fuel is pumped into the carburetor and fuel lines and the engine starts. Turn the engine off. **See following NOTE.**
5. **XRT 850:** Place the Forward/Reverse handle in the NEUTRAL position and the neutral lockout switch in the MAINTENANCE position. Crank the engine until fuel is pumped into the carburetor and fuel lines and the engine starts. Turn the engine off and return the neutral lockout switch to the OPERATE position. **See following NOTE.**

NOTE: Due to the oil added to the engine in preparation for storage, engine may smoke excessively for a short time when it is run for the first time after storage.

6. Adjust tires to recommended tire pressure. **See Section 2 – Vehicle Specifications.**
7. Perform the Pre-Operation and Daily Safety Checklist. **See the vehicle owner's manual.**

STORAGE – ELECTRIC VEHICLE

See General Warning on page 1-1.

⚠ WARNING

- Turn the key switch to the OFF position, remove the key, and leave the Forward/Reverse handle or switch in the NEUTRAL position during storage. This is to prevent unintentionally starting the vehicle or a fire hazard. Place the Tow/Run switch in the TOW position.
- Do not attempt to charge frozen batteries or batteries with bulged cases. Discard the battery. Frozen batteries can explode.

⚠ CAUTION

- Batteries in a low state of charge will freeze at low temperatures.
- To avoid exposing electrical components to moisture and subsequent damage, do not use any type of pressure washing or steam cleaning equipment to wash the vehicle.

PREPARING THE ELECTRIC VEHICLE FOR EXTENDED STORAGE

1. Fully charge batteries. **See Battery Charger on page 24-12.**
2. Batteries should be clean and free of corrosion. Wash tops and terminals of batteries with a solution of baking soda and water (237 mL (1 cup) baking soda per 3.8 L (1 gallon) of water). Rinse solution off batteries. Do not allow this solution to enter the batteries. Be sure terminals are tight. Let the terminals dry and then coat them with Battery Terminal Protector Spray.
3. Store vehicle in a cool, dry place. This will minimize battery self-discharge.
4. Adjust tires to recommended tire pressure. **See Section 2 – Vehicle Specifications.**
5. Perform semiannual periodic lubrication. **See Periodic Lubrication Schedules on page 10-4.**
6. Thoroughly clean front body, rear body, seats, battery compartment, and underside of vehicle.
7. Do not engage the park brake. Chock the wheels to prevent the vehicle from rolling.
8. Keep batteries fully charged during storage.
 - Leave battery chargers plugged in during storage. The onboard computer will automatically activate the charger when necessary. If charger cannot remain plugged in, or AC power will not be available during extended storage, disconnect the batteries for storage (**Figure 1-2, Page 1-3**). **See following CAUTION.**

CAUTION

- Be sure to check the batteries and charger monthly to maintain correct battery water level and to ensure the charger is operating correctly during storage.

RETURNING THE STORED ELECTRIC VEHICLE TO SERVICE

1. If necessary, connect batteries, and tighten terminals to 12.4 N·m (110 in-lb).
2. Fully charge batteries.
3. Adjust tires to recommended tire pressure. **See Section 2 – Vehicle Specifications.**
4. Perform the Pre-Operation and Daily Safety Checklist. **See the vehicle owner's manual.**

SECTION 4 – BODY AND TRIM

⚠ DANGER

- See General Warning on page 1-1.

⚠ WARNING

- See General Warning on page 1-1.

CLEANING THE VEHICLE

See General Warning on page 1-1.

CAUTION

- Do not use detergents or cleaning solvents that contain ammonia, aromatic solvents, or alkali materials on body panels or seats.
- Do not allow battery acid to drip on body panels. Battery acid will cause permanent damage. Wash spilled battery acid from body panels immediately.

These vehicles are equipped with ABS front body and TPO rear bodies. Use only commercially available automotive cleaners with a sponge or soft cloth for normal cleaning. A garden hose at normal residential water pressure is adequate.

We do not recommend any type of pressure washing or steam cleaning. Such a process (especially if the body has been removed) will expose electrical components to moisture. Moisture entering electrical components can result in water damage and subsequent component failure.

Use non-abrasive wax products. Battery acid, fertilizers, tars, asphalt, creosote, paint, or chewing gum should be removed immediately to prevent possible stains. **See following NOTE.**

NOTE: *Dispose of waste water properly.*

SEAT CLEANING

To preserve seat appearance, clean regularly with mild soap or detergent applied with a sponge or soft cloth. Use a soft bristle brush to clean areas that are especially soiled. Use the following guidelines:

Light Soiling: A solution of 10% liquid dish soap and warm water applied with a soft, damp cloth is recommended. A soft bristle brush may be used if necessary. Wipe off any residue with a water dampened cloth.

Difficult Stains: Dampen a soft, white cloth with a solution of 10% household bleach (sodium hypochlorite) and 90% water. Rub gently to remove stain, then rinse with a water dampened cloth to remove bleach concentration.

More Difficult Stains: Perform previous procedure using full-strength bleach, or allow bleach to puddle on affected area for approximately 30 minutes. Rinse with a water dampened cloth to remove any remaining bleach concentration. **See following CAUTION.**

CAUTION

- To prevent damage to the vehicle when removing difficult stains or heavy soiling, remove the seat bottom from the vehicle first.

FRONT AND REAR BODY REPAIR

See General Warning on page 1-1.

MINOR SCRATCHES AND SURFACE BLEMISHES

For minor scratches or blemishes in the body that do not penetrate the finish:

1. Thoroughly clean the affected area using a strong, non-abrasive detergent and hot water, then clean with Ultra-Kleen[®] Solvent Cleaner to remove any oil-based contaminants.
2. Lightly buff imperfection with a clean soft cloth or buff pad. Do not use any kind of rubbing (abrasive) compound on body assemblies.
3. Wax the entire body part to restore luster and weather protection.

SMALL SCRATCHES THAT CANNOT BE BUFFED OUT

1. Thoroughly clean the affected area with alcohol and then dry thoroughly.
2. Using 240 grit or finer sandpaper, lightly sand the scratch to feather the edges. Finish sand the scratch with 320 grit or finer paper to remove gloss from the surface. Sand as little body surface as possible beyond the scratch. **See following CAUTION.**

CAUTION

- **Be careful not to sand completely through the finish to the body material.**
3. Using the brush provided with the touch-up paint apply paint to the scratch. Multiple layers of paint may be required to fill the scratch.
 4. Allow paint to dry completely (approximately 10-20 minutes), then lightly buff the imperfection.
 5. Wax the entire body part to restore luster and weather protection.

Touch-Up Paint Color Chart

COLOR	CLUB CAR P/N
Black	101997207
Classic Blue (Navy)	101997211
Green	101997209
Metallic Silver	TBD
Red	101997203

GOUGES, PUNCTURES, TEARS, LARGE SCRATCHES, AND ABRASIONS

Touch-up is not recommended. Replace the entire body part or have it repaired by a professional paint and body repair shop with experience repairing TPO bodies.

FRONT BODY – 800 AND 810

See General Warning on page 1-1.

BUMPER/BRUSH GUARD REMOVAL

1. Remove bolts (3) and lock nuts (4) (Figure 4-1, Page 4-3 or Figure 4-2, Page 4-3).
2. Remove screws (5) and pull the bumper (1) or brush guard (2) from vehicle. See following WARNING.

⚠ WARNING

- Have another person hold the bumper or brush guard firmly against the frame when removing the last bolt. The bumper weighs approximately 40 pounds. Hold the bumper or brush guard securely during removal to avoid personal injury.
- Do not operate the vehicle without an installed front bumper or brush guard that is specifically designed and approved for use on this vehicle. Instability in the vehicle could cause serious injury or death.

BUMPER/BRUSH GUARD INSTALLATION

1. Position the bumper (1) or brush guard (2) against body and front frame and loosely install top bolts (3) and lock nuts (4) (Figure 4-1, Page 4-3 or Figure 4-2, Page 4-3). See preceding WARNING.
2. Install bottom screws (5) and tighten to 14 ft-lb (19 N·m).
3. Tighten lock nuts (4) to 17.5 ft-lb (24 N·m).

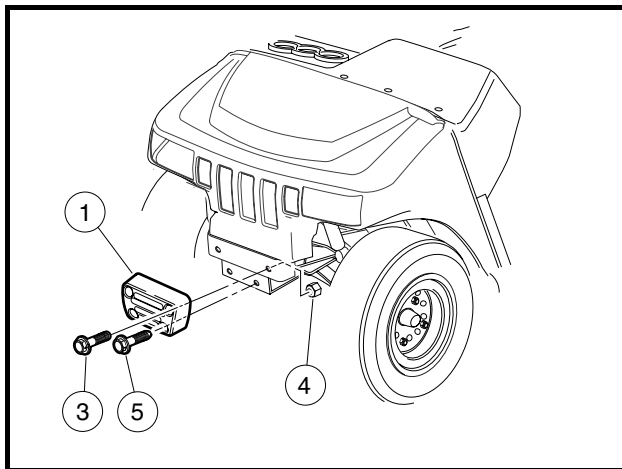

Figure 4-1 Bumper – 800 and 810

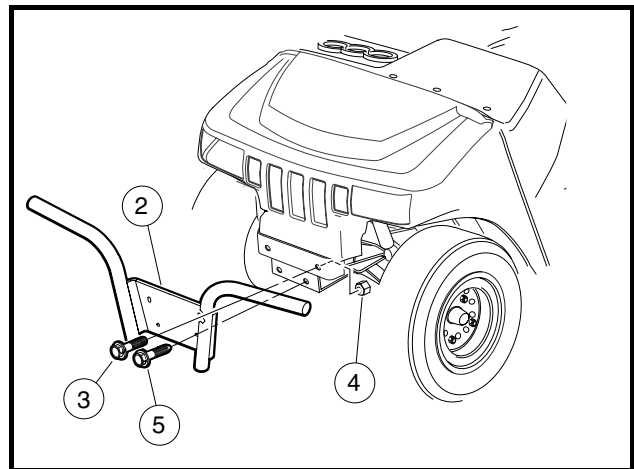

Figure 4-2 Brush Guard – 800 and 810

FRONT BODY REMOVAL

1. Remove bumper or brush guard. See Bumper/Brush Guard Removal on page 4-3.
2. Remove caps (5) from body and dash screws (Figure 4-3, Page 4-5).
3. Remove screws (4) and plastic scalloped washers (6) from body and body support and slide body away from dash.
4. Remove plastic screws from sides of dash and body.

5. Pull front body (9) from body covers (12) and (13).

NOTE: Body cover is not attached to the vehicle frame and may stay with the body when removed.

6. Disconnect headlights from wire harness at spade connectors and remove from the vehicle.

MOLDED DASH REMOVAL

1. Remove instrument panel:
 - 1.1. Loosen and remove the seven Tuflok screws securing the instrument panel to the dash (7) (**Figure 13-18, Page 13-15**). See **Key Switch Removal on page 13-14**.
 - 1.2. Pull panel away from the dash to access electrical components.
 - 1.3. Disconnect the wires from the electrical components mounted on the instrument panel. Do not allow wires to touch.
 - 1.4. Slide instrument panel up and away from the steering column.
2. Slide the three dash clips (15) along the bottom edge of the dash up and away from the frame and floor mat (**Figure 4-3, Page 4-5**).
3. Raise dash up and pass steering wheel through instrument panel opening to remove dash from vehicle.

MOLDED DASH INSTALLATION

1. Pass the steering wheel through the instrument panel opening in the dash (**Figure 4-3, Page 4-5**).
2. Attach the dash clips along the bottom edge of the dash onto the frame above the floor mat.
3. Install the instrument panel:
 - 3.1. Attach electrical components to connections on the back of the instrument panel
 - 3.2. Position the instrument panel onto the dash and push plastic fasteners into place.
4. Install front body. See **Front Body Installation on page 4-4**.

FRONT BODY INSTALLATION

1. Position front body onto frame and attach headlights to wire harness at spade connectors.
2. Install body (9) under body covers (12) and (13) and align holes with dash and body support (**Figure 4-3, Page 4-5**).
3. Install body and dash screws and scalloped washers on the top of the body. Tighten to 45 in-lb (5 N·m).
4. Attach plastic caps (5) onto dash screws.
5. Install plastic screws on the sides of the dash and body.
6. Install bumper or brush guard. See **Bumper/Brush Guard Installation on page 4-3**.

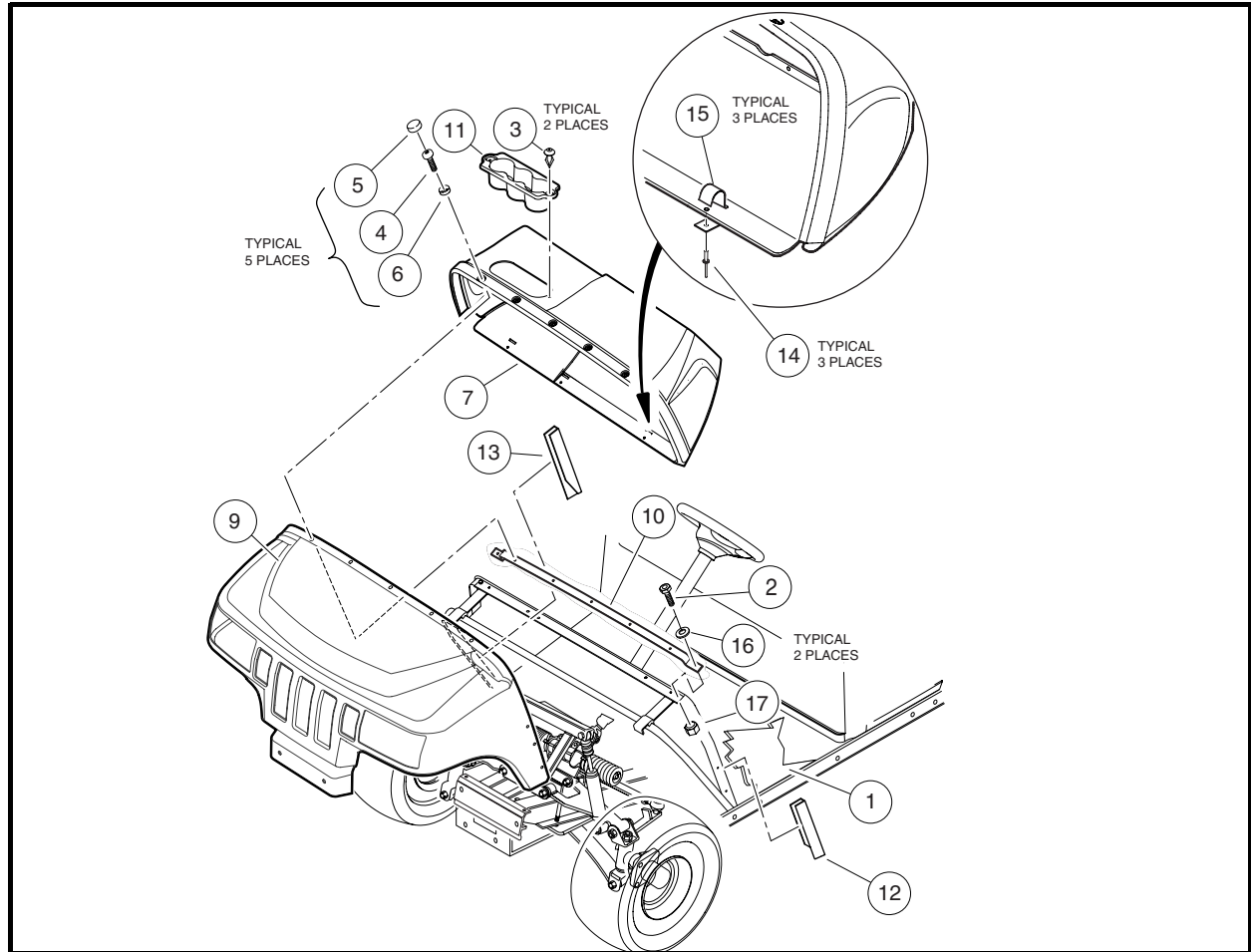

Figure 4-3 Front Body Assembly – 800 and 810

FRONT BODY – 850

See General Warning on page 1-1.

BUMPER/BRUSH GUARD (STANDARD) REMOVAL

1. Remove bolts (4) and lock nuts (5) (Figure 4-4, Page 4-6).
2. Remove screws (6) and pull the standard bumper (1) from vehicle. **See following WARNING.**

⚠ WARNING

- Have another person hold brush guard firmly against the frame when removing the last bolt. The brush guard weighs approximately 40 pounds. Hold the brush guard securely during removal to avoid personal injury.
- Do not operate the vehicle without an installed front bumper and brush guard that are specifically designed and approved for use on this vehicle. Instability in the vehicle could cause serious injury or death.

3. Remove screws (7) securing the standard brush guard to the vehicle.
4. Remove bolts (8), washers (9) and spacers (10) and pull the standard brush guard (2) from the vehicle.

BUMPER/BRUSH GUARD (STANDARD) INSTALLATION

1. Position the standard brush guard (2) on vehicle and loosely install spacers (10), washers (9), bolts (8) and screws (7) (**Figure 4-4, Page 4-6**). **See preceding WARNING.**
2. Position the standard bumper (1) against body and front frame and loosely install top bolts (4) and lock nuts (5).
3. Install bottom screws (6) and tighten to 14 ft-lb (19 N·m).
4. Tighten lock nuts (5) to 17.5 ft-lb (24 N·m).

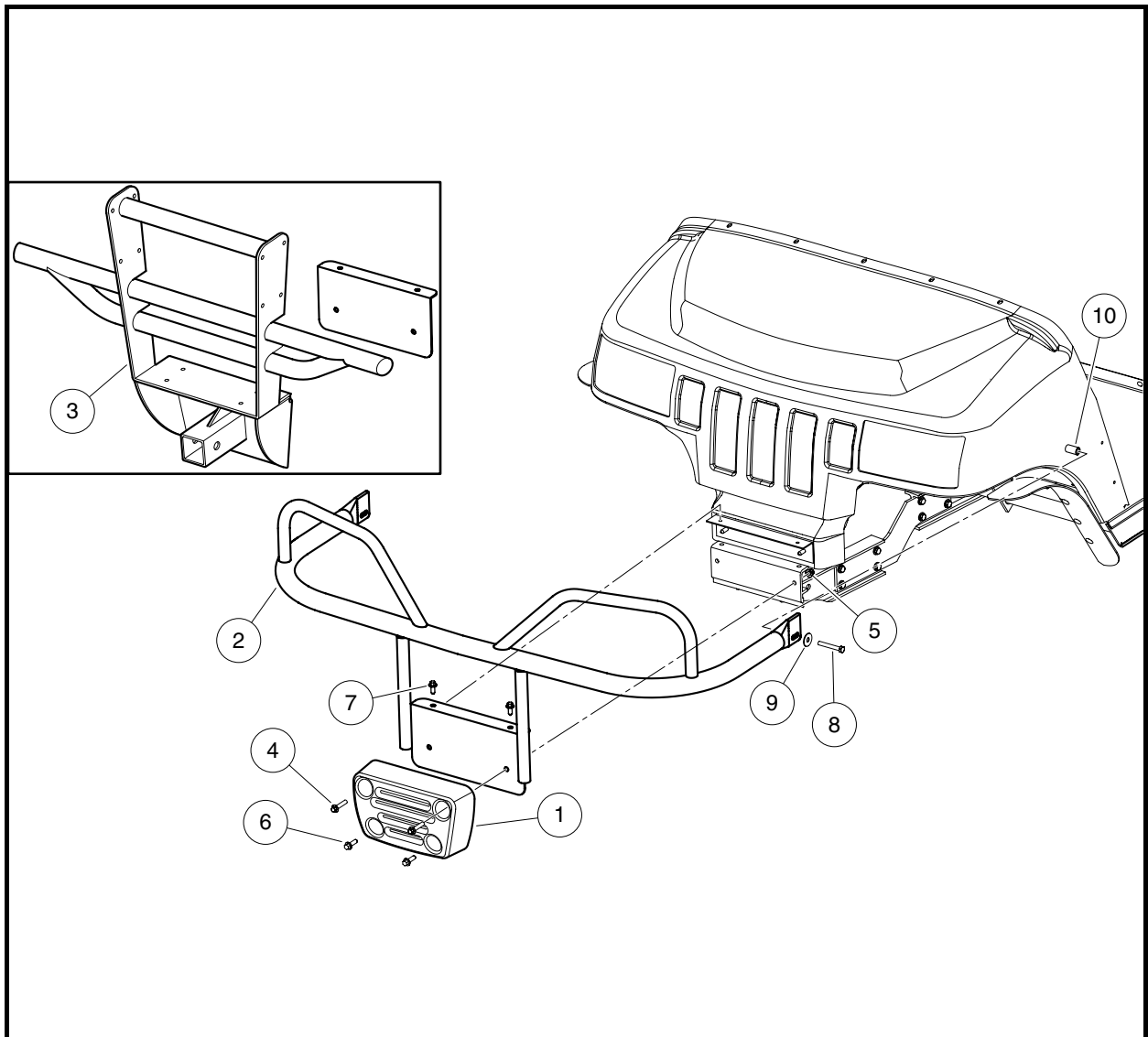

Figure 4-4 Standard Bumper and Brush Guard – 850 (Heavy Duty Shown in Inset)

BUMPER/BRUSH GUARD (HEAVY DUTY) REMOVAL

1. Remove bolts (4) and lock nuts (5) (**Figure 4-4, Page 4-6**).
2. Remove screws (6) and pull the heavy duty bumper/brush guard (3) from vehicle. **See following WARNING.**

⚠ WARNING

- **Have another person hold brush guard firmly against the frame when removing the last bolt. The brush guard weighs approximately 40 pounds. Hold the brush guard securely during removal to avoid personal injury.**
- **Do not operate the vehicle without an installed front bumper and brush guard that are specifically designed and approved for use on this vehicle. Instability in the vehicle could cause serious injury or death.**

BUMPER/BRUSH GUARD (HEAVY DUTY) INSTALLATION

1. Position the heavy duty bumper/brush guard (3) against body and front frame and loosely install top bolts (4) and lock nuts (5) (**Figure 4-4, Page 4-6**). **See preceding WARNING.**
2. Install bottom screws (6) and tighten to 14 ft-lb (19 N·m).
3. Tighten lock nuts (5) to 17.5 ft-lb (24 N·m).

FRONT REMOVAL

1. Remove bumper/brush guard. **See Bumper/Brush Guard (Standard) Removal on page 4-5 or Bumper/Brush Guard (Heavy Duty) Removal on page 4-7.**
2. Remove caps (1) from screws (2) (**Figure 4-5, Page 4-8**).
3. Remove screws (2) and plastic scalloped washers (3) securing the dash trim strip (4) and front body (5).
4. Remove covers (6 and 7) and plastic rivets (8) from each side of front body.
5. Disconnect wire harness from headlights and remove front body from vehicle.

FRONT BODY INSTALLATION

1. Position front body (5) onto frame and connect wire harness to headlights.
2. Align front body (5) and dash trim strip (4) holes with holes in frame and install the five screws (2) and scalloped washers (3). Tighten to screws to 45 in-lb (5 N·m). Attach plastic caps (1) onto screws (2).
3. Secure each side of front body to frame with plastic rivets (8).
4. Install body covers (6) and (7) (**Figure 4-5, Page 4-8**).
5. Install plastic screws (5) on the sides of the dash and body.
6. Install bumper and brush guard. **See Bumper/Brush Guard (Standard) Installation on page 4-6 or Bumper/Brush Guard (Heavy Duty) Installation on page 4-7.**

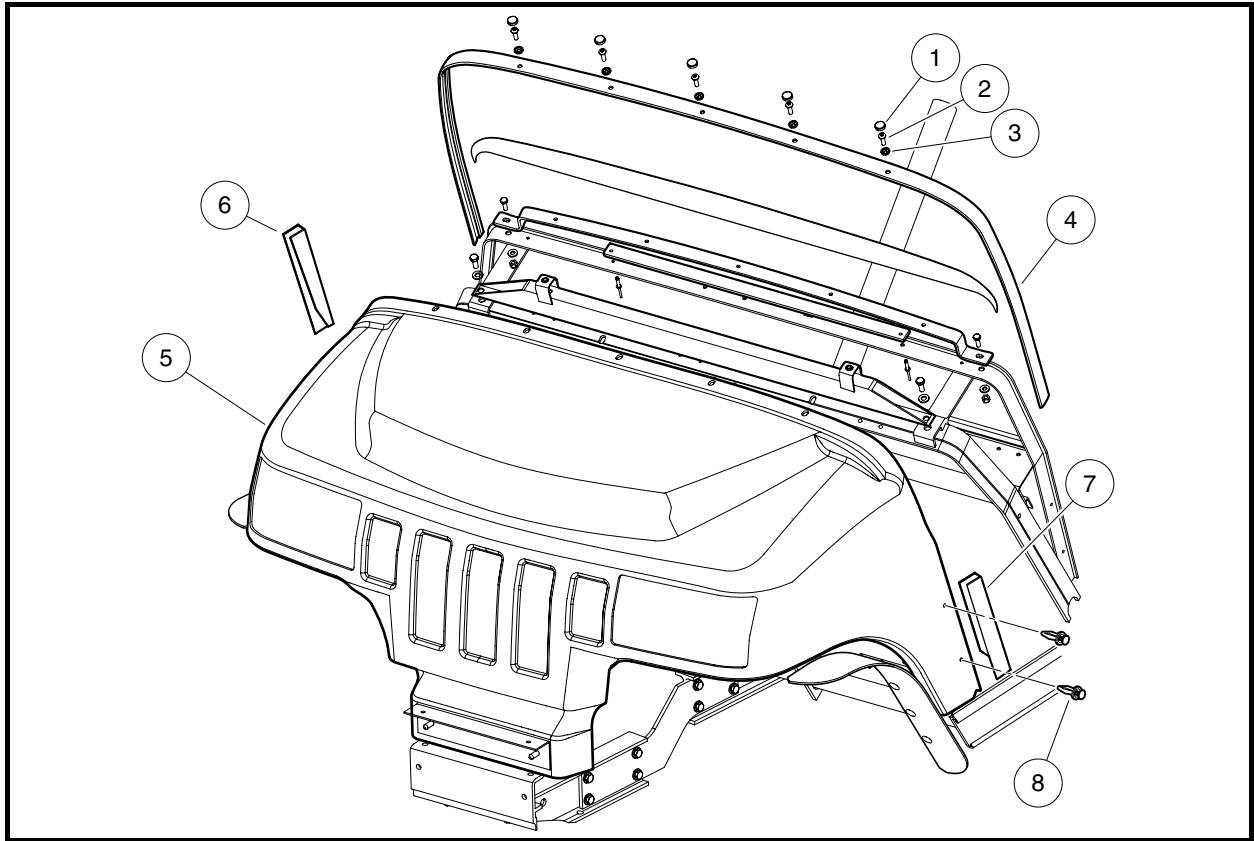

Figure 4-5 Front Body Assembly – 850

CARGO BED – 800 AND 810

See General Warning on page 1-1.

CARGO BED REMOVAL

NOTE: This procedure requires two people.

1. Raise bed and remove the rue rings on the end of each clevis pin.
2. Remove hinge clevis pins and remove bed from vehicle. **See following CAUTION and WARNING.**

CAUTION

- Support bed as pins are removed.
- Keep bed hinges as close to alignment as possible to avoid binding the pins during removal.

WARNING

- Keep hands and arms from between the bed and vehicle frame and do not allow the bed to drop.

CARGO BED INSTALLATION

NOTE: This procedure requires two people.

Lubricate the hinge clevis pins with light motor oil prior to assembly.

1. Position the bed to align with the hinge locations.
2. Install hinge clevis pins and washers, with the head of the pin to the inside portion of the bed. **See following CAUTION and WARNING.**

CAUTION

- Keep bed hinges as close to alignment as possible to avoid binding the pins during removal.

⚠ WARNING

- Keep hands and arms from between the bed and vehicle frame and do not allow the bed to drop.
3. Install rue rings and washers on the end of the hinge clevis pins.
 4. Lower the bed onto the bed latch plates. Adjust the latch plates if necessary.

BED LATCH ASSEMBLY

1. Remove the two latch link support bolts and remove latch rod and catch plate assembly from bed (**Figure 4-6, Page 4-9**).
2. Remove and replace any damaged or broken latch springs.



Figure 4-6 Bed Latch Link Bolt



Figure 4-7 Passenger Side Catch Rods and Catch Plate

Catch Rod and Catch Plate Removal

1. Remove latch springs.
2. Remove bolts and mechanical lock nuts from latch link and catch plates (**Figure 4-7, Page 4-9**).
3. Remove bronze bearings from catch plates.

4. Pry off push nuts from catch rod ends (**Figure 4-9, Page 4-10**). See following **NOTE**.

NOTE: Push nuts cannot be reused. Replace with either new push nuts or use cotter pins and washers.

Catch Rod and Catch Plate Installation

1. Install new bronze bearings into the catch plates.
2. Install the bolts and use new mechanical lock nuts to assemble the catch plates and latch link. Tighten hardware to 75 in-lb (8.4 N·m), then back-off 1/2 turn so that latch operates freely.
3. Install bed catch rods. Use new push nuts or use a flat washer and cotter pin to secure the ends of the rods (**Figure 4-9, Page 4-10**).
4. Install new springs from the catch plates to the catch rods (**Figure 4-8, Page 4-10**).



Figure 4-8 Latch Spring

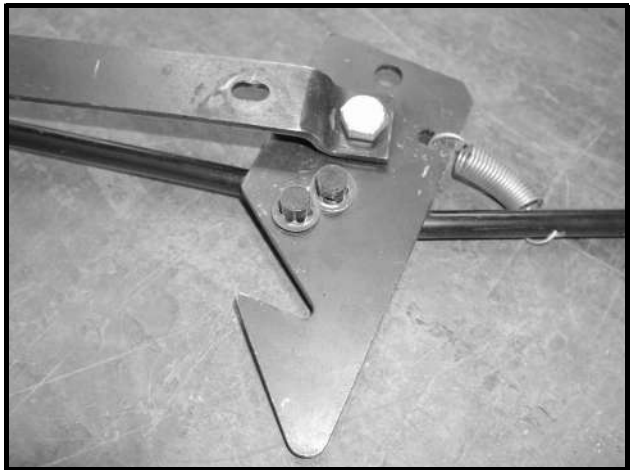

Figure 4-9 Push Nuts

Bed Hinge and Support Bracket Removal

1. Remove steel bushings and urethane bushings from hinge brackets (**Figure 4-10, Page 4-11**).
2. Remove bolts from hinges and remove hinges from supports.
3. Remove support channel bolts and bushings from hinge support channel (**Figure 4-11, Page 4-11**).
4. Remove hinge support bolts and supports (**Figure 4-11, Page 4-11**). See following **NOTE**.

NOTE: Note the location of the two different size bolts.

It may be necessary to deflect the rear fender slightly to remove support bolts.

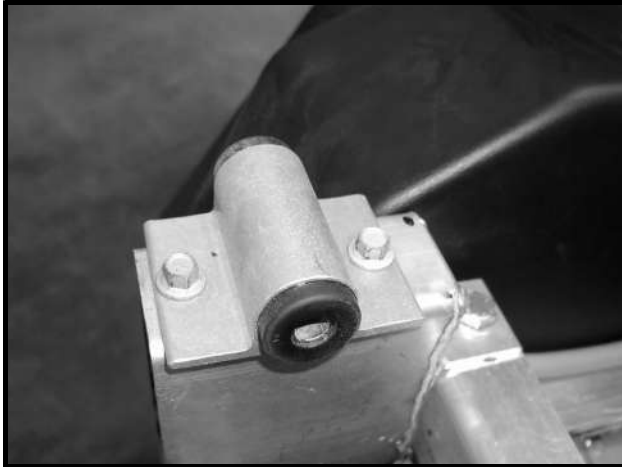

Figure 4-10 Bed Hinge



Figure 4-11 Hinge Support

BED LATCH ASSEMBLY INSTALLATION

1. Position latch link and catch plate assembly onto bed with support located at bolt holes and catch rods positioned into bed slots.
2. Attach latch link with screws. Tighten hardware to 7 ft-lb (9.5 N·m) (**Figure 4-6, Page 4-9**).

SEAT BACK SUPPORT BRACKETS – 800 AND 810

See General Warning on page 1-1.

NOTE: The bed latch plates are a part of each of the seat back support bracket. Removing latch plates will require adjustment for bed catch plates (**Figure 4-12, Page 4-11**).



Figure 4-12 Bed Latch Plates

SEAT BACK SUPPORT BRACKET REMOVAL

1. Remove bolts from seat back and support brackets and remove seat back.

2. Remove seat back support bolts and bed support weldment with bed bumpers from seat back supports (**Figure 4-13, Page 4-12**).
3. Remove seat back support bolts from body and remove from vehicle (**Figure 4-14, Page 4-12**).

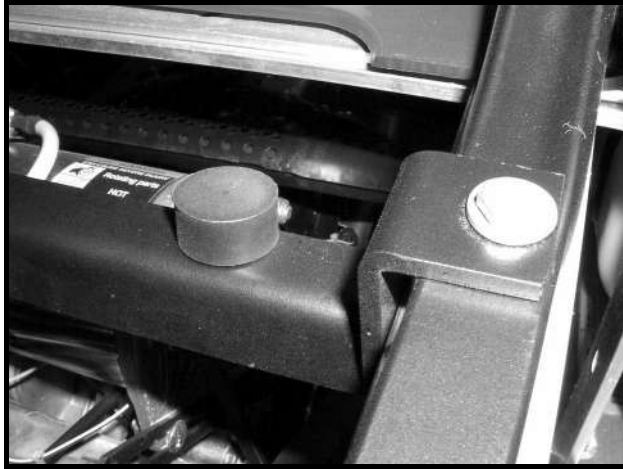

Figure 4-13 Seat Weldment Support



Figure 4-14 Seat Back Body Support

SEAT BACK SUPPORT BRACKET INSTALLATION

1. Align passenger and driver side seat back support brackets with holes in body (**Figure 4-14, Page 4-12**). See following **NOTE**.

NOTE: Striker plates should be to the outside of each bracket.

2. Install bracket bolts to body and tighten hardware to 14.5 ft-lb (19.6 N·m).
3. Position bed support with bumpers onto seat back supports and frame (**Figure 4-13, Page 4-12**).
4. Install bracket and bed support bolts to frame and tighten to 100 in-lb (11.3 N·m).

REAR BODY AND FENDERS – 800 AND 810

See General Warning on page 1-1.

NOTE: The driver side rear fender can be removed without removing any other component, but the passenger side rear fender cannot be removed without either removing the fuel tank or removing the rear body. It is easier to remove the rear body than to remove the fuel tank.

REAR BODY REMOVAL

1. Remove the seat from the rear body.
2. Disconnect the battery cables as instructed. See **WARNING “To avoid unintentionally starting...”** in **General Warning on page 1-2**. Remove cargo bed. See **Cargo Bed Removal on page 4-8**.
3. Remove seat back support brackets. See **Seat Back Support Bracket Removal on page 4-11**.
4. Remove the two screws, nuts and washers located at the bottom edge of the seat support panel (in kick-plate just above the floormat) (**Figure 4-15, Page 4-13**).

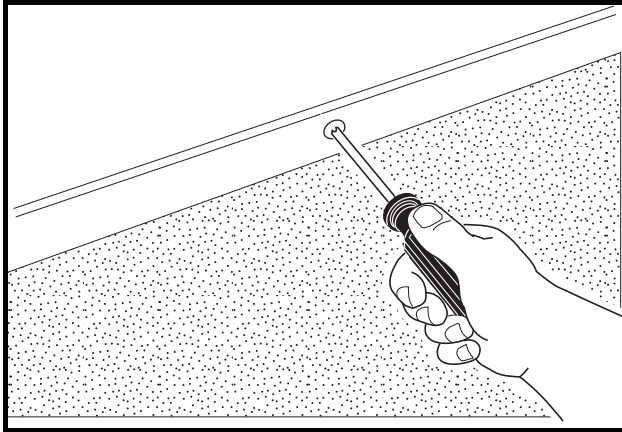

Figure 4-15 Remove Kick-Plate Screws

Electric vehicles:

5. Disconnect or remove charger receptacle:
 - 5.1. Remove wire ties binding 10-gauge red wire (from charger receptacle to battery) to the vehicle frame. Disconnect the 10-gauge red wire at the positive post of battery no. 1.
 - 5.2. Remove the retaining nut and disconnect the 10-gauge black wire (from the onboard computer) from the receptacle.
 - 5.3. Unplug the fuse holder assembly to disconnect the gray sense lead from the receptacle.

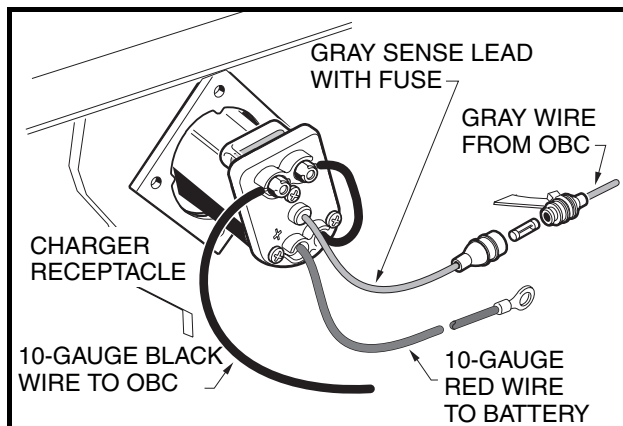

Figure 4-16 Charger Receptacle

6. If the Forward/Reverse switch is mounted on the rear body, disconnect and remove Forward/Reverse switch. **See Forward/Reverse Switch Removal on page 23-4.**

Gasoline Vehicles:

NOTE: To remove the rear body, the choke button assembly does not have to be removed from the body. However, adjustment of the choke positioner may be necessary after the rear body is reinstalled.

7. If the Forward/Reverse shifter is mounted on the rear body, remove Forward/Reverse shifter.
8. Remove two bolts, washers and nylon lock nuts from rear fenders at frame locations (**Figure 4-17, Page 4-14**).
9. Lift rear body and fenders from the vehicle.



Figure 4-17 Rear Fender Frame Bolts

REAR FENDER REMOVAL

NOTE: The driver side rear fender can be removed without removing any other component, but the passenger side rear fender cannot be removed without either removing the fuel tank or removing the rear body. It is easier to remove the rear body than to remove the fuel tank.

1. Disconnect the battery cables as instructed. See **WARNING “To avoid unintentionally starting...”** in **General Warning on page 1-2.**
2. **Driver side rear fender:**
 - 2.1. Remove the seat.
 - 2.2. Raise the cargo bed.
 - 2.3. Remove rear fender frame bolt (**Figure 4-17, Page 4-14**).
 - 2.4. Remove the top body and fender bolt.
 - 2.5. Remove the two outside body and fender bolts and remove the fender from the vehicle.
3. **Passenger side rear fender:**
 - 3.1. Remove the seat.
 - 3.2. Remove the cargo bed. See **Cargo Bed Removal on page 4-8.**
 - 3.3. Remove the seat back support brackets. See **Seat Back Support Bracket Removal on page 4-11.**
 - 3.4. Remove rear fender frame bolt.
 - 3.5. Remove the rear body. See **Rear Body Removal on page 4-12.**
 - 3.6. Place body and fender on a clean flat surface and remove the top body and fender bolt.
 - 3.7. Remove the two outside body and fender bolts and separate the passenger side fender from the rear body.

REAR FENDER INSTALLATION

NOTE: If both fenders have been removed, attach them to the rear body first, then install the rear body with fenders attached.

Rear Body and Fenders

NOTE: Use the floor as a method of keeping the fenders and rear body in alignment for height.

1. Position the rear body on a large flat surface such as a concrete floor. **See following NOTE.**
2. Attach both fenders to the sides on the rear body and leave bolts loose.
3. Attach both fenders to the top locations on the rear body and snug bolts but do not tighten.
4. Tighten the side bolts on both fenders to 25 in-lb (2.8 N·m).
5. Tighten top bolts on both fenders to 25 in-lb (2.8 N·m).

Driver side rear fender:

NOTE: If only the driver side fender has been removed, use the following procedure for installation

1. Install fender in reverse order of removal.
2. Tighten side bolts to 25 in-lb (2.8 N·m).
3. Tighten top bolt to 25 in-lb (2.8 N·m).

REAR BODY INSTALLATION

NOTE: This procedure is easier using two people.

1. Position rear body with fenders attached onto the vehicle frame.
2. Position front edge of the body behind floor mat back rail and down into the side trim.
3. Install the front edge of the body to the rail with screws and tighten to 50 in-lb (5.6 N·m).
4. Install the rear bolts on both fenders and tighten to 50 in-lb (5.6 N·m).
5. If previously removed, install Forward/Reverse selector.

REAR BODY – 850

See General Warning on page 1-1.

REAR BODY REMOVAL

1. Disconnect the battery cables as instructed. **See WARNING “To avoid unintentionally starting...” in General Warning on page 1-1.**
2. Remove the forward-facing seat from the rear body.
3. Remove two mats from the rear body by gently pulling mats at each plastic barrel.
4. Remove two screws (1), washers and lock nuts located at the rear of the vehicle (**Figure 4-18, Page 4-16**).
5. Remove two screws, washers and nuts located at the bottom edge of the seat support panel (in kick-plate just above the floor mat) (**Figure 4-19, Page 4-16**).

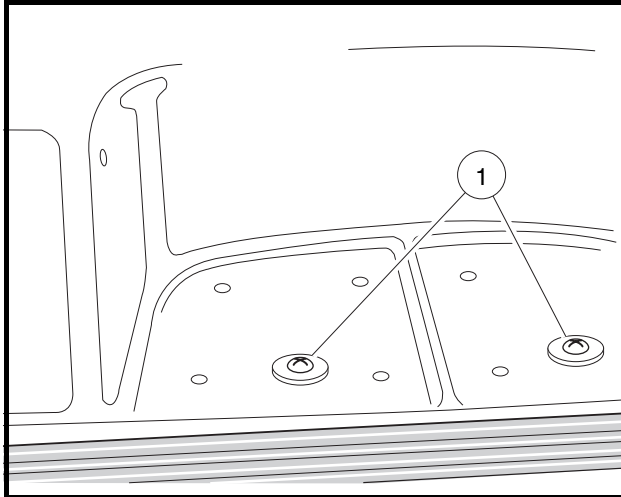

Figure 4-18 Rear Body Screws

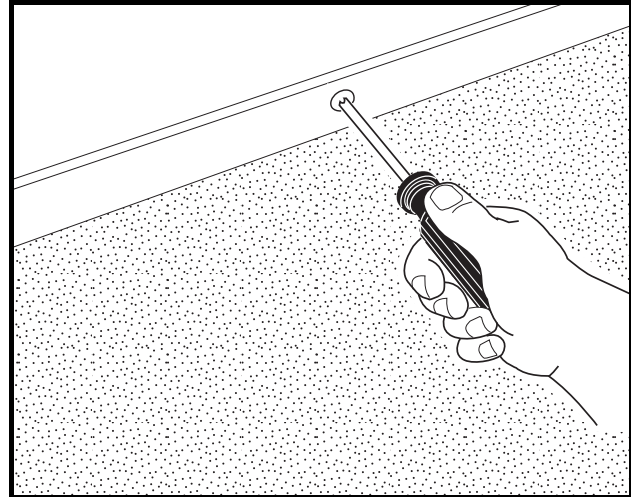

Figure 4-19 Kick-Plate Screws

850 Electric Vehicles Only:

NOTE: To remove the rear body, the charger receptacle must be disconnected, but does not have to be removed from the body.

6. Disconnect the charger receptacle (**Figure 4-16, Page 4-13**):
 - 6.1. Remove wire ties binding 10-gauge red wire (from charger receptacle to battery) to the vehicle frame. Disconnect the 10-gauge red wire at the positive post of battery no. 1.
 - 6.2. Remove the retaining nut and disconnect the 10-gauge black wire (from the onboard computer) from the receptacle.
 - 6.3. Unplug the fuse holder assembly to disconnect the gray sense lead from the receptacle.

850 Gasoline Vehicles Only:

NOTE: To remove the rear body, the choke button assembly does not have to be removed from the body. However, adjustment of the choke positioner may be necessary after the rear body is reinstalled.

7. Remove two nylon lock nuts from fuel pump and remove fuel pump from seat support.

Vehicles Equipped with Rear Facing Seat:

8. Remove handrail and rear seat:
 - 8.1. Remove the hardware (1) that secures the rear handrails (2 and 3) to the rear footrest assembly (**Figure 4-20, Page 4-17**).
 - 8.2. Remove the hardware (4) that connects the two rear handrails (2 and 3) together between the seat back support brackets (5 and 6).
 - 8.3. Remove the hardware (7) that secures the two rear handrails (2 and 3) to the seat back support brackets (5 and 6) and remove the handrails from the vehicle.
 - 8.4. Remove the hardware (8) that secures the rear seat support (9) to the chassis.
 - 8.5. Remove the hardware (10) that secures the seat bottom/cargo deck (11) to the seat back support brackets (5 and 6) and remove the seat bottom/cargo deck from the vehicle.
 - 8.6. Remove the hardware (12 and 13) that secures the seat back support brackets (5 and 6) to the rear body and lift the seat back support brackets away from the vehicle.

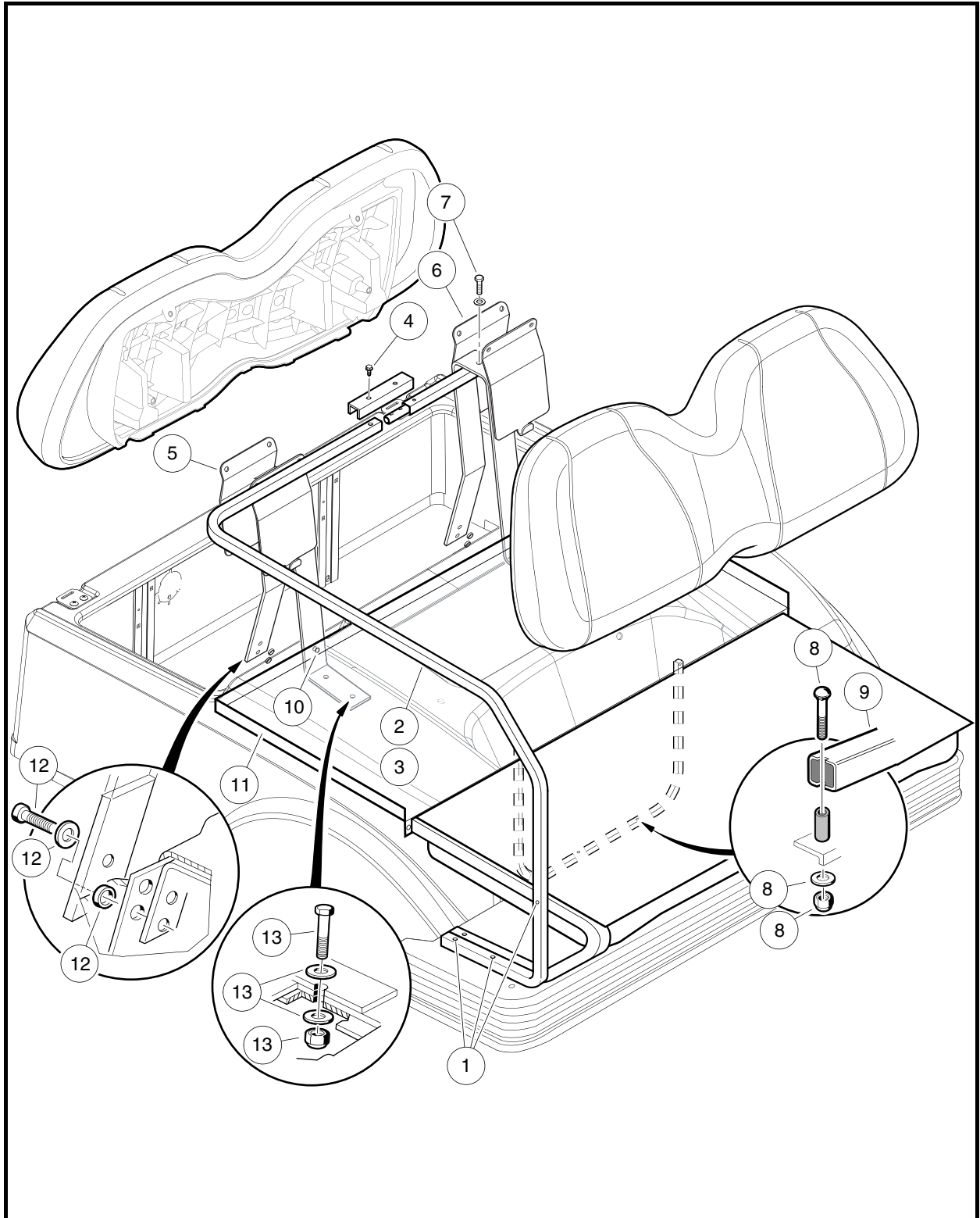

Figure 4-20 Rear Seat/Handrail – 850

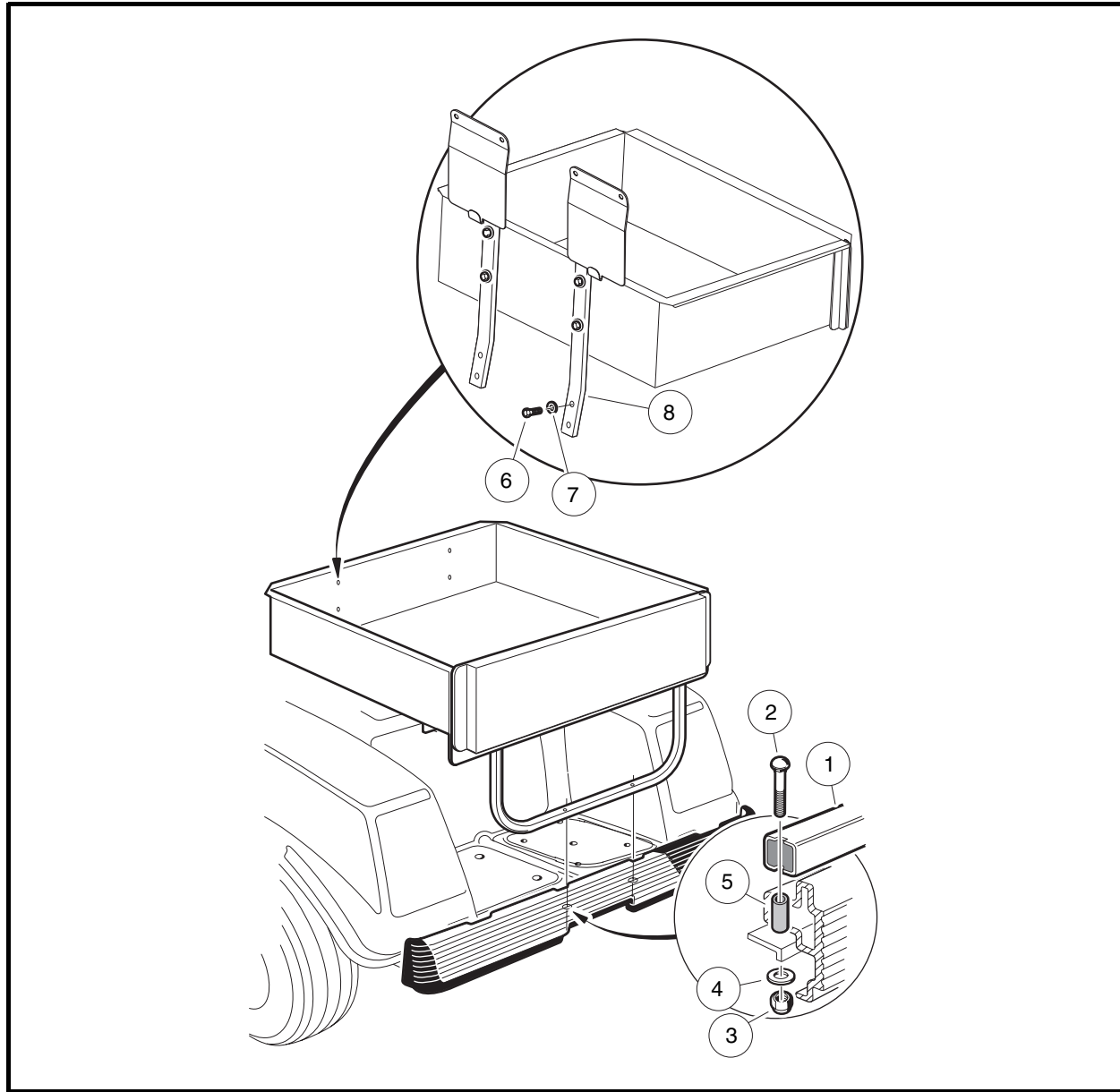

Figure 4-21 Cargo Bed – 850

Vehicles Equipped with Cargo Bed:

9. Remove seat and cargo bed:
 - 9.1. Remove the bottom seat cushion from the rear body.
 - 9.2. Remove the two bolts (2), nuts (3), flat washers (4) and spacers (5) that attach the cargo bed support (1) to the body (**Figure 4-21, Page 4-18**).
 - 9.3. Remove the four screws (6) and flat washers (7) that attach the seat back supports (8) to the body.
 - 9.4. Remove cargo box and seat back assembly from the vehicle.
10. Lift the rear body from the vehicle.

REAR BODY INSTALLATION

1. Install in reverse order of removal.
 - 1.1. Tighten kick-plate nuts to 48 in-lb (5.4 N·m) while holding the kick-plate screws (**Figure 4-19, Page 4-16**).
 - 1.2. Tighten two screws (1) and lock nuts located under rear body to 20 in-lb (2.3 N·m) (**Figure 4-18, Page 4-16**).
 - 1.3. **Gasoline vehicles only:**
 - 1.3.1. Install fuel pump. **See Fuel Pump Installation on page 16-21.**
 - 1.3.2. Check the choke positioner for proper adjustment on gasoline-powered vehicles and adjust if necessary.
 - 1.4. **Electric vehicles only:**
 - 1.4.1. If necessary, install the charger receptacle and tighten the four screws to 16 in-lb (1.8 N·m) (**Figure 4-16, Page 4-13**). Tighten the nut that secures the 10-gauge black wire to the charger receptacle to 23 in-lb (2.6 N·m).

Vehicles Equipped with Rear Facing Seat:

- 1.5. Tighten hardware (12) attaching the front legs of the seat back support assembly to the chassis to 120 in-lb (13.6 N·m) (**Figure 4-20, Page 4-17**).
- 1.6. Tighten the hardware (13) attaching the rear legs of the seat back support assembly to the chassis to 11 ft-lb (14.9 N·m).
- 1.7. Tighten the hardware (10, 7 and 1) to 124 in-lb (14 N·m).
- 1.8. Tighten the hardware (8) securing the rear seat support (9) to the chassis to 108 in-lb (12.2 N·m).
- 1.9. Tighten the hardware (4) to 65 in-lb (7.35 N·m).

Vehicles Equipped with Cargo Bed:

- 1.10. Tighten the bolts (6) attaching the seat back supports (8) to the chassis to 156 in-lb (17.6 N·m) (**Figure 4-21, Page 4-18**).
- 1.11. Tighten the nuts (3) securing the cargo bed support (1) to the chassis to 108 in-lb (12.2 N·m).
- 1.12. Install seat bottom.

FLOOR MAT

See General Warning on page 1-1.

FLOOR MAT REMOVAL

1. Remove the brake and accelerator pedals. **See Section 5 – Accelerator and Brake Pedal Group.**
2. Slide the mat from under the edge of the rear body. Loosen the rear body screws if necessary.
3. Slide the mat away from the trim up under the dash and remove the floor mat.

FLOOR MAT INSTALLATION

1. Reverse the removal procedure to install the floormat. If loosened, tighten rear body screws to 48 in-lb (5.4 N·m).
2. Install the brake and accelerator pedals. **See Section 5 – Accelerator and Brake Pedal Group.**

SECTION 5 – ACCELERATOR AND BRAKE PEDAL GROUP

⚠ DANGER

- See General Warning on page 1-1.

⚠ WARNING

- See General Warning on page 1-1.

BRAKE PEDAL AND PARK BRAKE

See General Warning on page 1-1.

BRAKE PEDAL REMOVAL

1. Disconnect the battery cables as instructed. **See WARNING “To avoid unintentionally starting...” in General Warning on page 1-2.**
2. Place chocks under the rear wheels and lift the front end of the vehicle with a chain hoist or floor jack. Place jack stands under the front cross tube of the vehicle frame and lower the vehicle onto the jack stands. **See following WARNING.**

⚠ WARNING

- **Lift only one end of the vehicle at a time. Use a suitable lifting device (chain hoist or hydraulic floor jack) with 1000 lb. (454 kg) minimum lifting capacity. Do not use lifting device to hold vehicle in raised position. Use approved jack stands of proper weight capacity to support the vehicle and chock the wheels that remain on the floor. When not performing a test or service procedure that requires movement of the wheels, lock the brakes.**
3. Remove the brake pedal assembly.
 - 3.1. Disconnect the equalizer rod (13) from the pedal shaft by removing the clevis pin (14) and bow-tie pin (15) (**Figure 5-1, Page 5-2**).
 - 3.2. Remove the nuts (5), washers (2), bolts (4) and mounting blocks (23). If the mounting blocks show signs of excessive wear or are damaged, they must be replaced with new ones before installing pedal assembly.
 - 3.3. Remove the nut (12) and brake stop bumper (11).
 - 3.4. Lift the pedal assembly (8) through the floorboard.

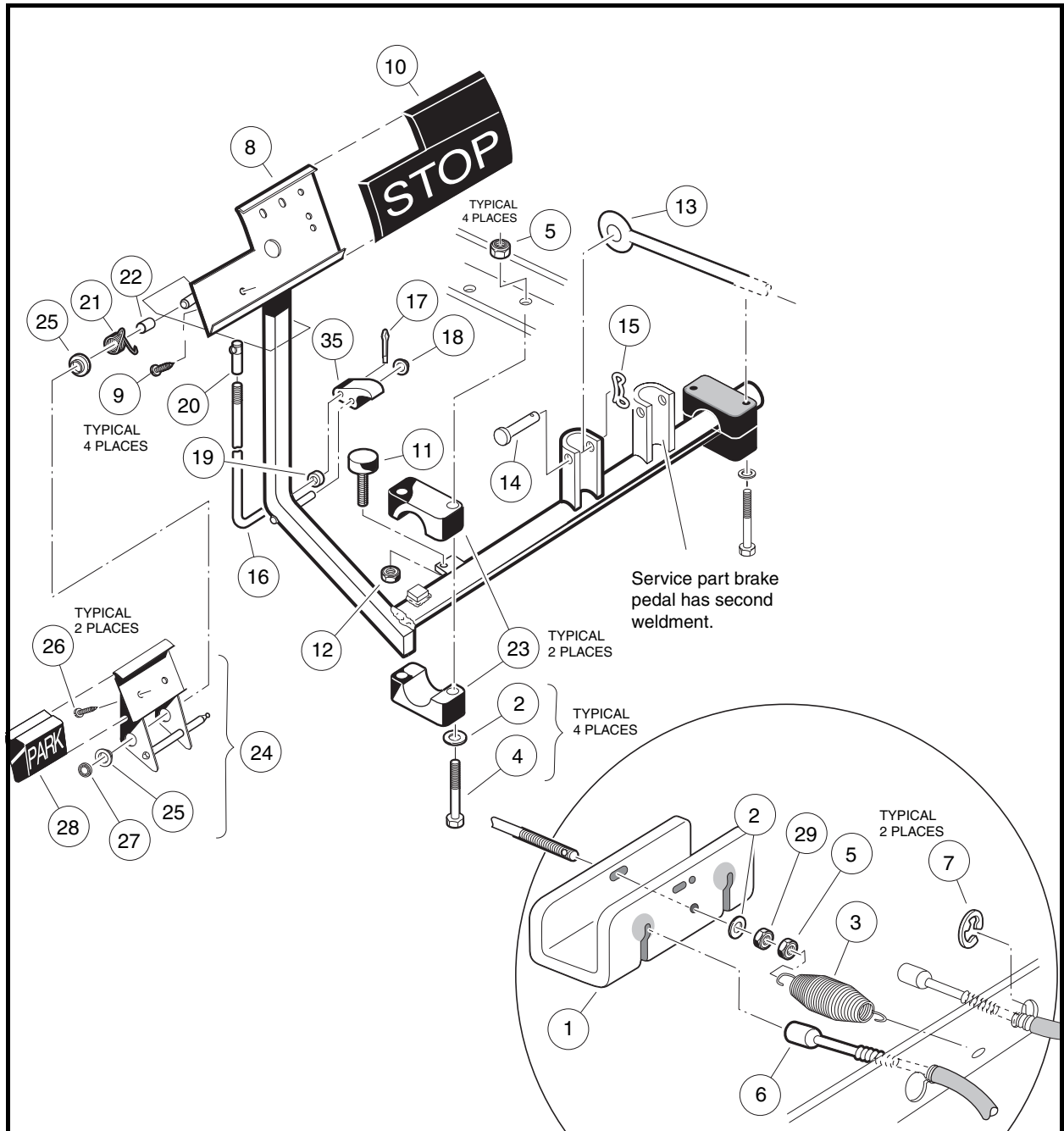

Figure 5-1 Brake and Park Brake Pedal Assembly

BRAKE PEDAL INSTALLATION

1. From the top side of the floorboard, insert the brake pedal assembly through the opening in the floor, and install the brake pedal stop bumper (11) on the brake pedal assembly (**Figure 5-1, Page 5-2**). Do not tighten the jam nut (12) at this time.
2. Secure the equalizer rod (13) to the brake pedal assembly (8) with the clevis pin (14) and bow-tie pin (15) as shown.
3. Position and attach brake pedal assembly, mounting blocks (23) and washers (2) to vehicle frame as shown. Tighten the bolts and nuts to 113 in-lb (12.8 N·m).

4. Tighten the nut (2) on the equalizer rod (1) so that brake pedal free-play is 1/4 inch to 1/2 inch (6 mm to 13 mm) (**Figure 5-2, Page 5-3**). **See following NOTE.**

NOTE: Brake pedal free-play is the distance the brake pedal can be pressed before the brake actuator arm moves.

5. Tighten the jam nut (3) while holding the adjustment nut (2) in the correct position (**Figure 5-2, Page 5-3**).
6. Adjust the pedal group. Refer to the appropriate adjustment procedure:
 - Pedal Group Adjustment – Gasoline Vehicle on page 5-11
 - Pedal Group Adjustment – Electric Vehicles on page 5-16

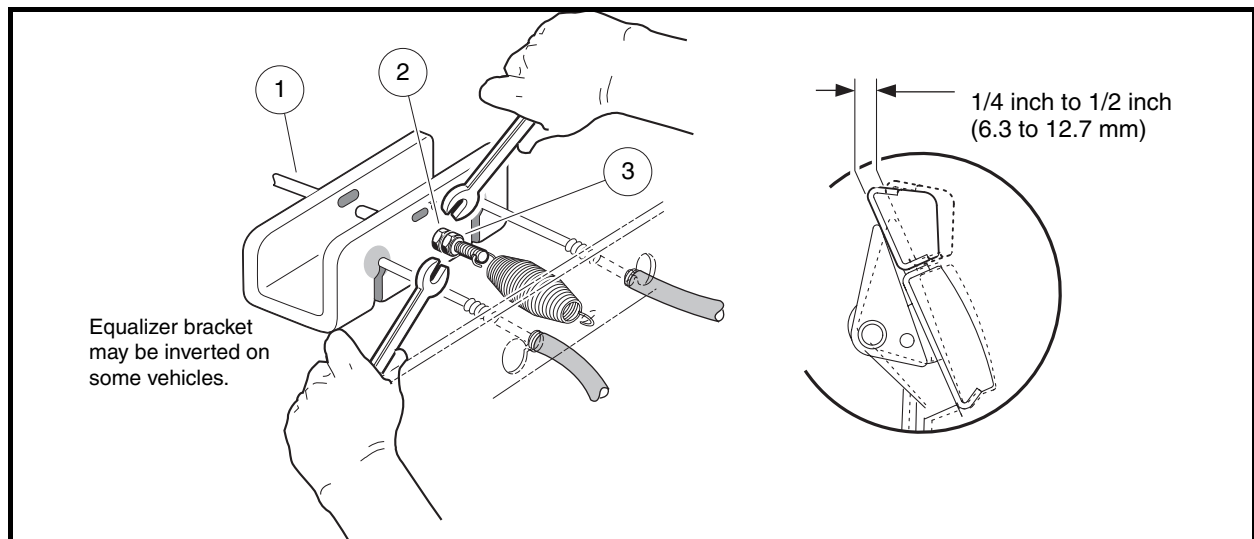

Figure 5-2 Brake Pedal Free-Play Adjustment

PARK BRAKE REMOVAL

1. Disconnect the battery cables as instructed. **See WARNING “To avoid unintentionally starting...” in General Warning on page 1-2.**
2. Place chocks under the rear wheels and lift the front end of the vehicle with a chain hoist or floor jack. Place jack stands under the front cross tube of the vehicle frame and lower the vehicle onto the jack stands. **See following WARNING.**

⚠ WARNING

- Lift only one end of the vehicle at a time. Use a suitable lifting device (chain hoist or hydraulic floor jack) with 1000 lb. (454 kg) minimum lifting capacity. Do not use lifting device to hold vehicle in raised position. Use approved jack stands of proper weight capacity to support the vehicle and chock the wheels that remain on the floor. When not performing a test or service procedure that requires movement of the wheels, lock the brakes.
3. Remove the park brake assembly.
 - 3.1. To remove the park brake rod and pawl assembly (16 through 19 and 35), remove the push nut (18) and disconnect the ball joint sleeve (20) from the park brake pedal (24) (**Figure 5-1, Page 5-2**). **See following NOTE.**

NOTE: New push nuts (18) and (27) must be used when reassembling the park brake (**Figure 5-3, Page 5-4**).

- 3.2. To remove the park brake pedal (1), remove the push nut (27), disconnect the torsion spring (21) (**Figure 5-3, Page 5-4**) and slide the pedal off of the shaft. **See preceding NOTE.**
- 3.3. Inspect all parts for wear or damage and replace as necessary.

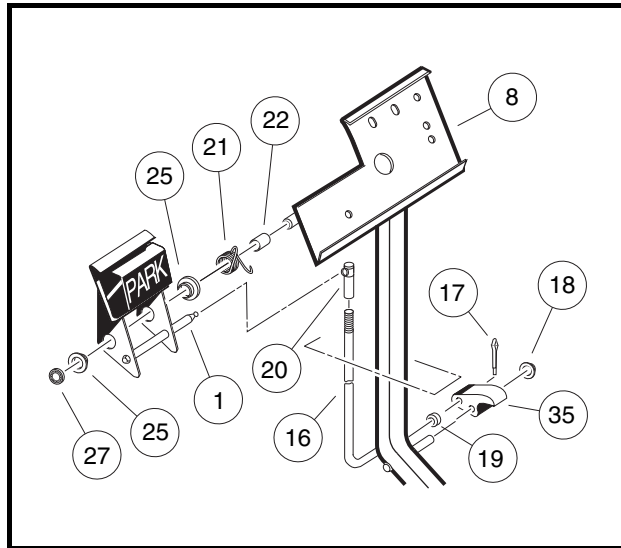

Figure 5-3 Park Brake Assembly

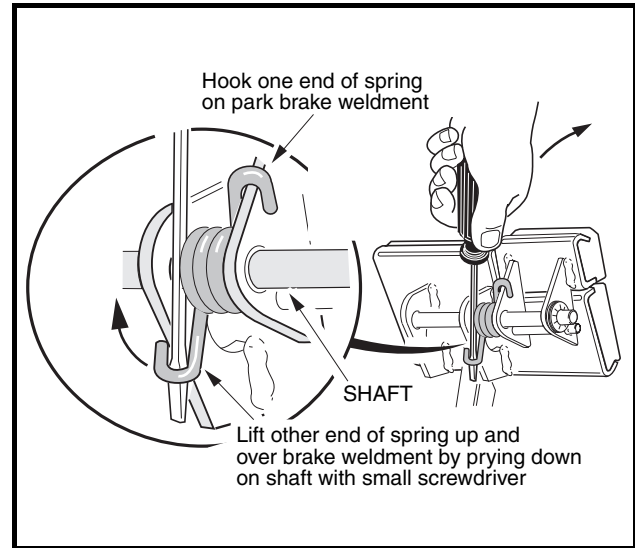

Figure 5-4 Torsion Spring Installation

PARK BRAKE INSTALLATION

1. From the bottom side of the floorboard, insert the park brake rod (16) through the brake pedal assembly opening. Then install the park brake pawl (35) onto the shaft on the brake pedal assembly (8) and also insert the park brake rod (16) into the park brake pawl.
2. Install the push nut (18) onto the park brake pawl shaft.
3. Install the spacer (22) and torsion spring (21) on the park brake pedal shaft on the brake pedal assembly.
4. Install the two bushings (25) in the park brake pedal and position the park brake pedal on the shaft on the brake pedal assembly weldment (**Figure 5-3, Page 5-4**). Then attach the ends of the torsion spring to the park brake pedal and to the brake pedal weldment as shown (**Figure 5-4, Page 5-4**).
5. Install the push nut (27) on the park brake pedal shaft (**Figure 5-3, Page 5-4**).
6. Connect park brake rod (16) ball joint to ball stud on park brake pedal assembly.
7. Adjust park brake ratchet/pawl gap and pawl engagement. Refer to the appropriate adjustment procedure:
 - **Pedal Group Adjustment – Gasoline Vehicle on page 5-12, Step 4**
 - **Pedal Group Adjustment – Electric Vehicles on page 5-17, Step 4**

ACCELERATOR PEDAL – GASOLINE VEHICLES

See General Warning on page 1-1.

NOTE: This section pertains to gasoline vehicles. For electric vehicles, proceed to Accelerator Pedal – Electric Vehicles on page 5-8.

ACCELERATOR PEDAL REMOVAL

1. Disconnect the battery cables as instructed. See **WARNING “To avoid unintentionally starting...”** in **General Warning on page 1-2.**
2. Place chocks under the rear wheels and lift the front end of the vehicle with a chain hoist or floor jack. Place jack stands under the front cross tube of the vehicle frame and lower the vehicle onto the jack stands. See following **WARNING.**

WARNING

- **Lift only one end of the vehicle at a time. Use a suitable lifting device (chain hoist or hydraulic floor jack) with 1000 lb. (454 kg) minimum lifting capacity. Do not use lifting device to hold vehicle in raised position. Use approved jack stands of proper weight capacity to support the vehicle and chock the wheels that remain on the floor. When not performing a test or service procedure that requires movement of the wheels, lock the brakes.**
3. Disconnect the accelerator rod assembly (17, 18, and 19) (**Figure 5-5, Page 5-6**) at the front and rear ball studs and remove it from the vehicle.
 4. Use a 9/16-inch socket and 9/16-inch wrench to remove the nut (23), two washers (25), and bolt (4) securing the accelerator pedal (1) to the pivot rod (6).
 5. Remove the nut (10) and ball stud (16) from the accelerator pivot rod assembly (6).
 6. Slide the spring retainer (11) off of the accelerator pivot rod.
 7. Inspect the pivot support bearing (9) for wear and replace if necessary.
 8. Use a marker to mark the position of the park brake ratchet (24) on the accelerator pivot rod (6). See following **NOTE.**
- NOTE:** Failure to mark position of the ratchet could cause it to be installed improperly, resulting in improper adjustment and possible failure of the park brake.
9. Remove the lock nut (26) from the accelerator pivot shaft (**Figure 5-5, Page 5-6**).
 10. Press the brake pedal slightly and slide the park brake ratchet (24) toward the end of the accelerator pivot rod. Rotate the ratchet and remove it from the pivot rod.
 11. Remove the pivot rod (6) and spacer (20) from the accelerator pivot rod supports (21).

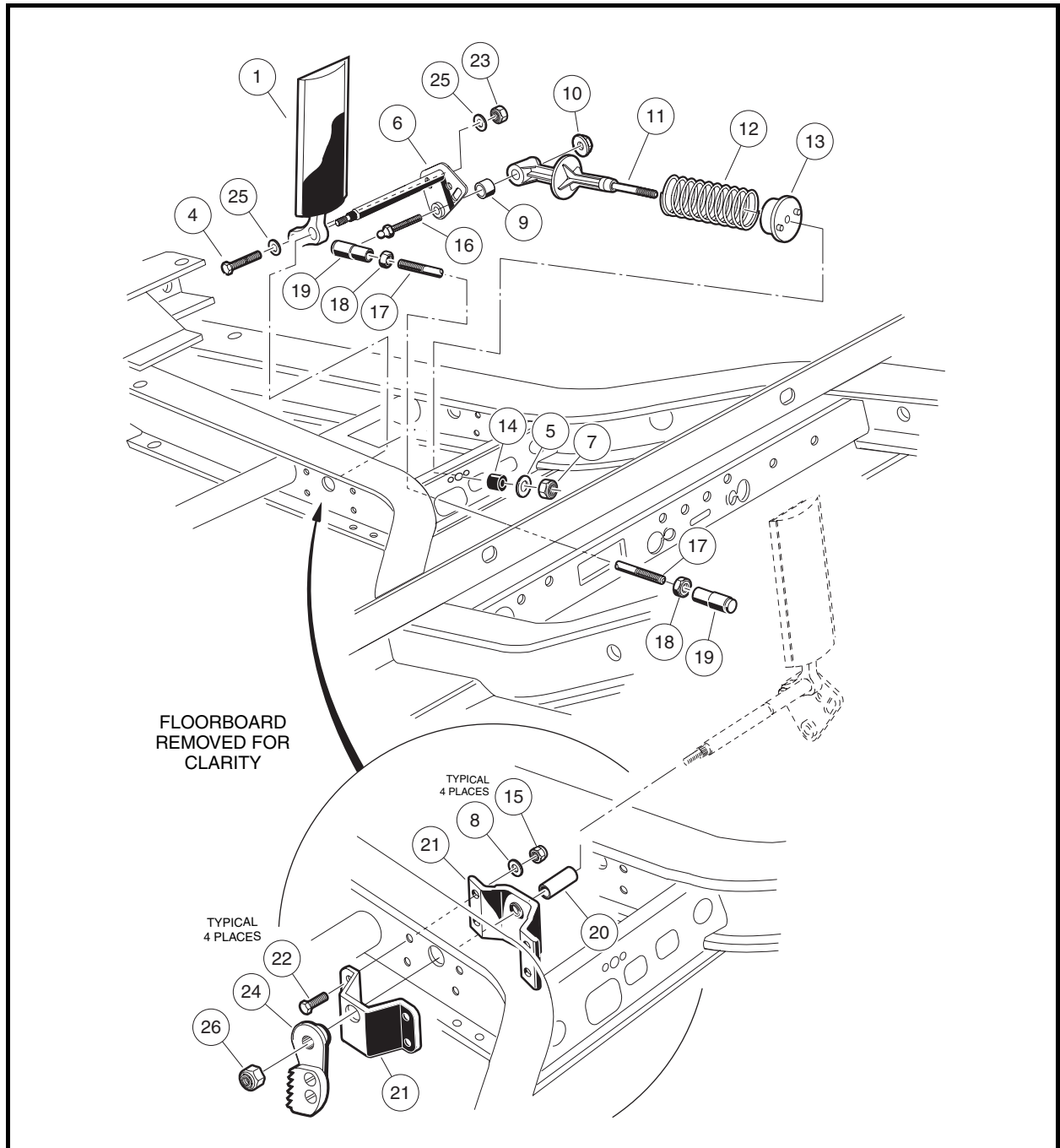

Figure 5-5 Accelerator Pedal Assembly – Gasoline Vehicles

12. Inspect the accelerator pivot rod supports (21) for wear or damage and replace as necessary. If the pivot rod supports do not require replacement, loosen, but do not remove the four bolts (22) and lock nuts (15) to make installation of the pivot rod easier.
13. Remove the accelerator pedal (1) from the vehicle.
14. Inspect all parts for wear and damage. Replace as necessary

ACCELERATOR PEDAL INSTALLATION

1. If the accelerator pivot rod supports were replaced, position the supports (21) on the vehicle frame and install the four bolts (22), flat washers (8), and lock nuts (15). Finger-tighten nuts at this time (**Figure 5-5, Page 5-6**).
2. Insert the lower end of the accelerator pedal (1) through the floorboard and install the accelerator pivot rod (6) through the uppermost hole in the pedal.
3. Install the plastic spacer (20) on the pivot rod.
4. Insert the pivot rod through the pivot rod supports on the vehicle frame.
5. Tighten the four bolts (22) attaching the pivot rod supports to the frame to 75 in-lb (8.5 N·m).
6. Insert the bolt (4), with washer (25), through the lower hole in the pedal and through the pivot rod. Secure with washer (25) and new lock nut (23) (**Figure 5-5, Page 5-6**). Finger-tighten lock nut at this time.
7. Install the ball stud (16) through the pivot rod. Install the spring retainer (11) onto the ball stud. Secure these parts with the nut (10). Tighten the nut to 50 in-lb (5.5 N·m).
8. Press the brake pedal slightly, and with the park brake ratchet oriented so that the tip of the ratchet is pointed toward the rear of vehicle, slide the ratchet onto the pivot rod (do not slide the ratchet onto the pivot rod splines). Release the brake pedal and allow the ratchet to rotate until its tip is pointed downward (**Figure 5-6, Page 5-7**). The ratchet should now rotate freely on the rod.

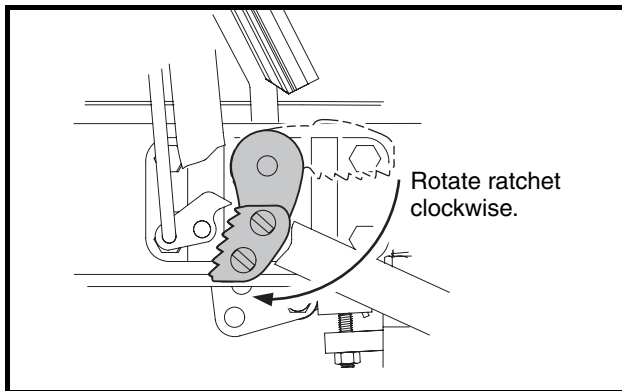

Figure 5-6 Ratchet Installation

9. Rotate ratchet clockwise until it touches the park brake pawl, then slide the ratchet onto the splines of the pivot rod (it may be necessary to push the pivot rod toward the driver-side of the vehicle to make the splines accessible). The ratchet may have to be rotated counterclockwise slightly to align the splines.
10. Move the pivot rod back toward the driver side of the vehicle and line up the match marks on the pivot rod and ratchet. Rotate the pivot rod back and forth slightly to align the splines and slide the ratchet onto the splines.
11. Install the lock nut (26) on pivot rod and tighten the nut to 18 ft-lb (24.5 N·m) (**Figure 5-5, Page 5-6**).
12. Install the accelerator rod assembly (17, 18, and 19).
13. Adjust the accelerator pedal height. Refer to the appropriate adjustment procedure:
 - **Pedal Group Adjustment – Gasoline Vehicle on page 5-14, Step 5**
 - Adjust the accelerator rod (gasoline vehicles only). **Pedal Group Adjustment – Gasoline Vehicle on page 5-14, Step 6**

ACCELERATOR PEDAL – ELECTRIC VEHICLES

See **General Warning** on page 1-1.

NOTE: This section pertains to electric vehicles only. For gasoline vehicles go to *Accelerator Pedal – Gasoline Vehicles* on page 5-5.

ACCELERATOR PEDAL REMOVAL

1. Disconnect the battery cables as instructed. See **WARNING “To avoid unintentionally starting...”** in **General Warning** on page 1-2.
2. Place chocks under the rear wheels and lift the front end of the vehicle with a chain hoist or floor jack. Place jack stands under the front cross tube of the vehicle frame and lower the vehicle onto the jack stands. See following **WARNING**.

⚠ WARNING

- **Lift only one end of the vehicle at a time. Use a suitable lifting device (chain hoist or hydraulic floor jack) with 1000 lb. (454 kg) minimum lifting capacity. Do not use lifting device to hold vehicle in raised position. Use approved jack stands of proper weight capacity to support the vehicle and chock the wheels that remain on the floor. When not performing a test or service procedure that requires movement of the wheels, lock the brakes.**
3. Remove the MCOR (2) and drive bar (3) as instructed (**Figure 5-7, Page 5-9**). See **MCOR Removal, Section 23, Page 23-8**.
 4. Use a 9/16-inch socket and 9/16-inch wrench to remove the nut (7), two washers (5), and bolt (4) securing the accelerator pedal (1) to the pivot rod (6) (**Figure 5-7, Page 5-9**).
 5. Remove the nut (10) and bolt (8) from the accelerator pivot rod assembly (6).
 6. Slide the spring retainer (11) off of the accelerator pivot rod.
 7. Inspect the pivot support bearing (9) for wear and replace if necessary.
 8. Use a marker to mark the position of the park brake ratchet (24) on the accelerator pivot rod (6). See following **NOTE**.

NOTE: Failure to mark position of the ratchet could cause it to be installed improperly, resulting in improper adjustment and possible failure of the park brake.

9. Remove the lock nut (23) from the accelerator pivot rod (**Figure 5-7, Page 5-9**).
10. Press the brake pedal slightly and slide the park brake ratchet (24) toward the end of the accelerator pivot rod. Rotate the ratchet and remove it from the pivot rod.
11. Remove the pivot rod (6) and spacer (20) from the accelerator pivot rod supports (21).
12. Inspect the accelerator pivot rod supports (21) for wear and damage and replace as necessary. If the pivot rod supports do not require replacement, loosen (but do not remove) the four bolts (22) and lock nuts (15) to make installation of the pivot rod easier.
13. Remove the accelerator pedal (1) from the vehicle.
14. Inspect all parts for wear and damage. Replace as necessary.

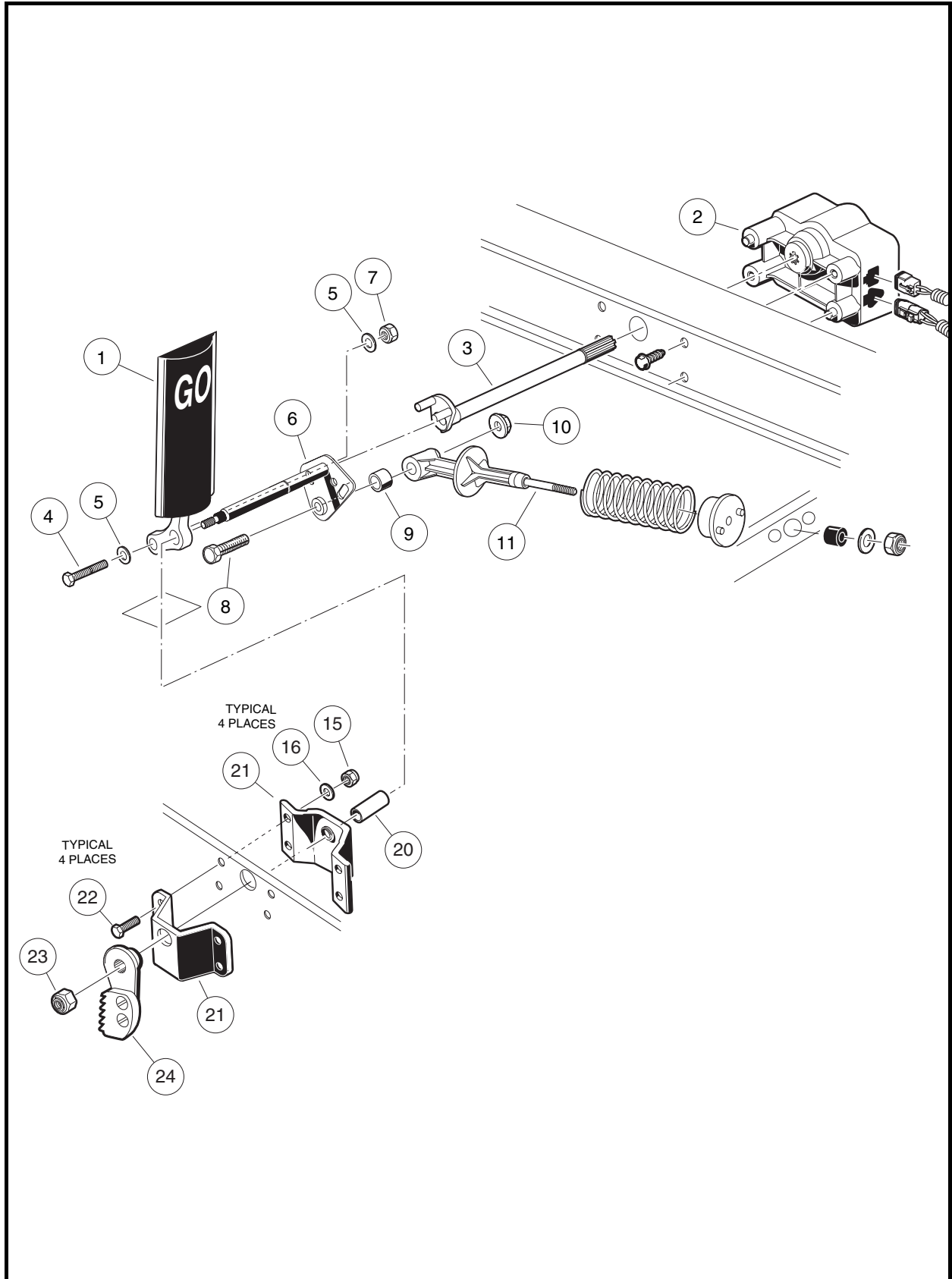

Figure 5-7 Accelerator Pedal – Electric Vehicle

ACCELERATOR PEDAL INSTALLATION

1. If the accelerator pivot rod supports were replaced, position the supports (21) on the vehicle frame and install the four bolts (22), flat washers (16), and lock nuts (15) (**Figure 5-7, Page 5-9**). Finger-tighten hardware at this time.
2. Insert the lower end of the accelerator pedal (1) through the floorboard and install the accelerator pivot rod (6) through the uppermost hole in the pedal.
3. Install plastic spacer (20) on pivot rod (6).
4. Insert the pivot rod through the pivot rod supports (21) on the vehicle frame.
5. Tighten the four bolts (22) attaching the pivot rod supports to the frame to 75 in-lb (8.5 N·m).
6. Insert the bolt (4), with washer (5), through the lower hole in the pedal and through the pivot rod. Secure with washer (5) and new lock nut (7). Finger-tighten lock nut at this time.
7. Install the bolt (8) through the pivot rod (6) and spring retainer (11). Secure these parts with the nut (10). Tighten the nut to 50 in-lb (5.5 N·m).
8. Press the brake pedal slightly, and with the park brake ratchet oriented so that the tip of the ratchet is pointed toward the rear of the vehicle, slide the ratchet onto the pivot rod (do not slide the ratchet onto the pivot rod splines). Release the brake pedal and allow the ratchet to rotate until its tip is pointed downward (**Figure 5-8, Page 5-10**). The ratchet should now rotate freely on the rod.

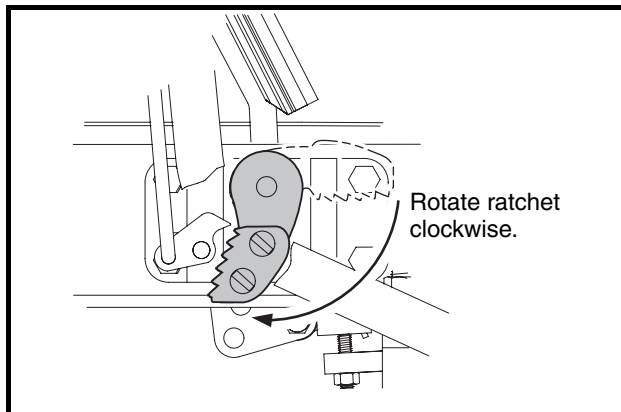

Figure 5-8 Ratchet Installation

9. Rotate the ratchet clockwise until it touches the park brake pawl, then slide the ratchet onto the splines of the pivot rod (it may be necessary to push the pivot rod toward the driver-side of the vehicle to make the splines accessible). The ratchet may have to be rotated counterclockwise slightly to align the splines.
10. Move the pivot rod back toward the driver-side of the vehicle and line up the match marks on the pivot rod and ratchet. Rotate the pivot rod back and forth slightly to align the splines and slide the ratchet onto the splines.
11. Install lock nut (23) on pivot rod (**Figure 5-7, Page 5-9**). Tighten to 18 ft-lb (24.5 N·m).
12. Install the MCOR (2) and drive bar (3) as instructed. **See MCOR Installation, Section 23, Page 23-9.**
13. Adjust the accelerator pedal height. **See step 5 of Pedal Group Adjustment – Electric Vehicles on page 5-19.**

PEDAL GROUP ADJUSTMENT – GASOLINE VEHICLE

See General Warning on page 1-1.

1. Disconnect the battery cables as instructed. See **WARNING “To avoid unintentionally starting...”** in **General Warning on page 1-2**.
2. Adjust brake pedal height.
 - 2.1. Chock wheels and release park brake. Lift rear of vehicle and place jack stands under the axle tubes to support the vehicle.
 - 2.2. To provide slack in the brake cables, loosen the equalizer retaining nuts (2 and 3) on the equalizer rods (1) (**Figure 5-9, Page 5-11**).

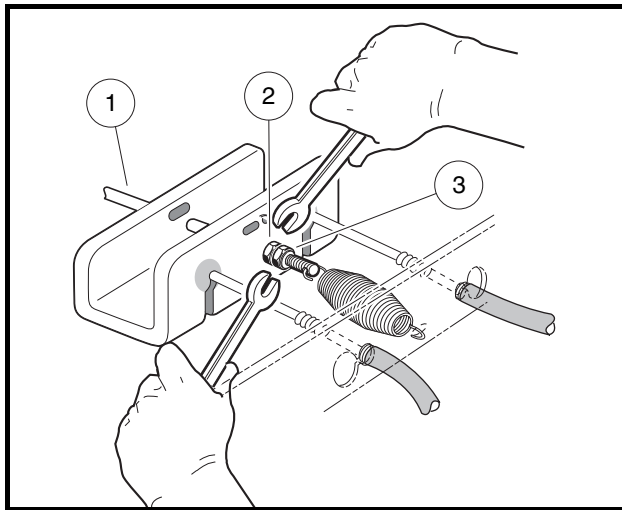

Figure 5-9 Loosen Rear Brake Equalizer Rod Nuts

- 2.3. Loosen the brake stop jam nut (31), then relieve pedal pressure on the stop by pushing down slightly on the pedal. Next, adjust the brake stop bumper (22) up or down (**Figure 5-10, Page 5-11**). Adjusting the bumper upward decreases distance between pedal and floorboard. Adjusting the bumper downward increases distance between pedal and floorboard. Proper brake pedal height is 6 inches (15.2 cm) (**Figure 5-11, Page 5-11**).
- 2.4. Tighten the jam nut (31) to 8 ft-lb (9.5 N·m) (**Figure 5-10, Page 5-11**).

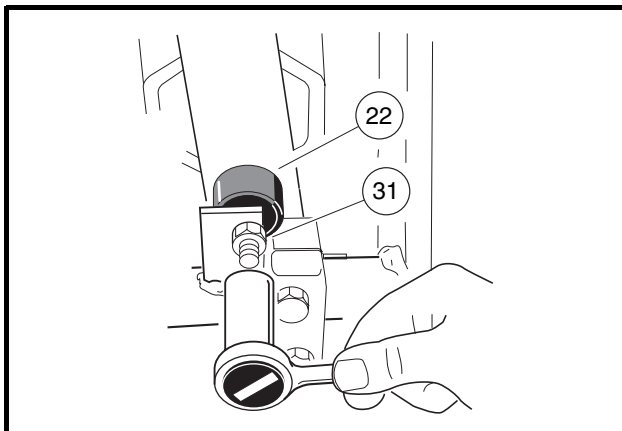

Figure 5-10 Brake Pedal Height Adjustment

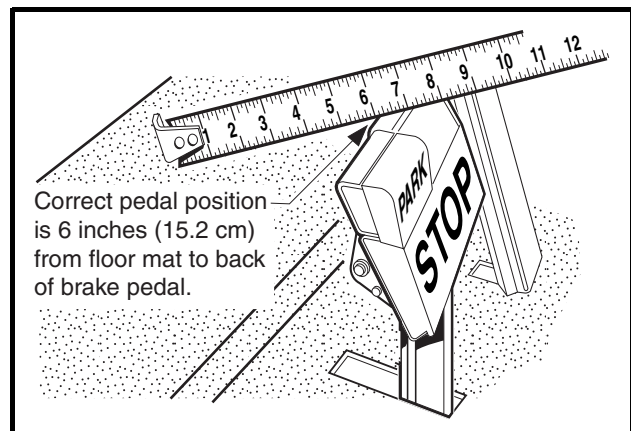

Figure 5-11 Brake Pedal Height Measurement

3. Adjust brake pedal free play. **See following NOTE.**

NOTE: Brake pedal free play is the distance the brake pedal can be pressed before the brake actuator arm (at the brake cluster) moves.

- 3.1. Measuring perpendicular from the floorboard to the back of the brake pedal, press the brake pedal and measure the distance that the pedal moves before all of the slack is taken out of the brake cables (**Figure 5-11, Page 5-11**).
- 3.2. Tighten the nut (2) on the equalizer rod (1) so that the brake pedal free play is 1/4 to 1/2 inch (6.3 to 12.7 mm) (**Figure 5-12, Page 5-12**).
- 3.3. Tighten the jam nut (3) while holding the adjustment nut (2) in the correct position.

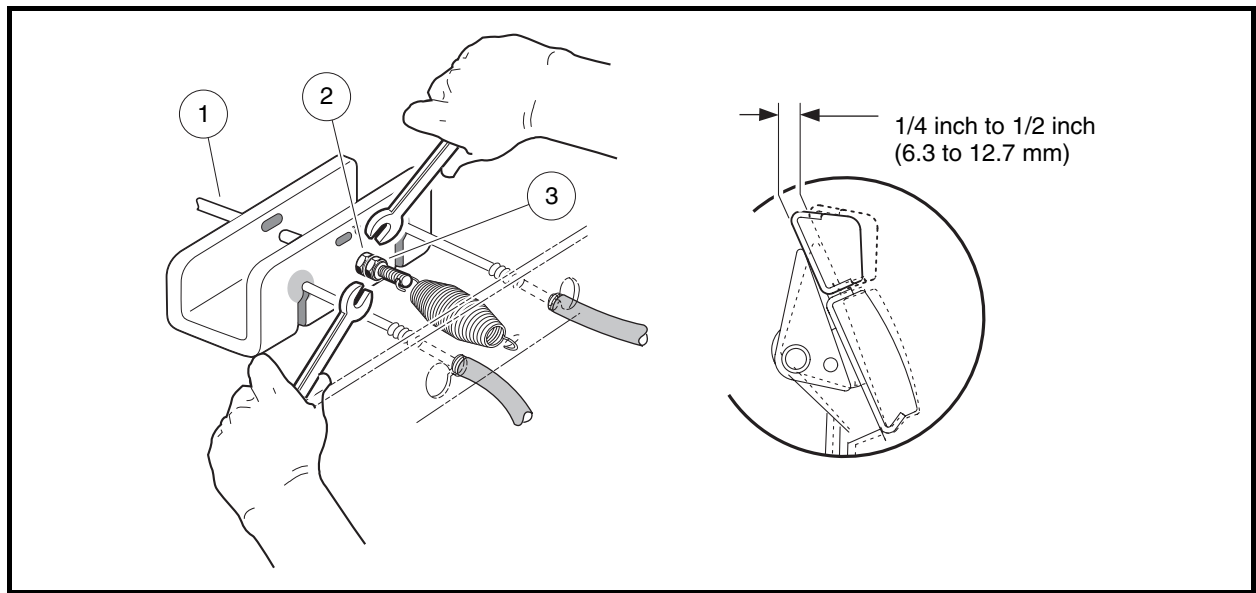

Figure 5-12 Brake Pedal Free-Play Adjustment

4. Adjust park brake ratchet/pawl gap and pawl engagement.

- 4.1. Inspect the park brake pawl and ratchet for excessive wear, grooves, cracks or chips. If either the pawl or ratchet is damaged, both must be replaced.
- 4.2. Adjust retaining nut (7) on spring support rod until there is a 0.060 inch (1.5 mm) gap between the pawl and the tips of the ratchet teeth. Use a feeler gauge to verify the gap (**Figure 5-13, Page 5-13**). The gap should be consistent through range of pawl movement. If the gap is not consistent, loosen the four bolts (6) securing the accelerator pivot rod supports and adjust the supports. If the gap becomes smaller as the park brake pedal is pressed, move the pivot rod supports slightly rearward until the gap is consistent. If the gap becomes larger as the park brake pedal is pressed, move the pivot rod supports slightly forward until gap is consistent. **See following NOTE.**

NOTE: The accelerator rod must also be checked if the ratchet/pawl gap is adjusted. **See step 6 of Pedal Group Adjustment – Gasoline Vehicle on page 5-14.**

The accelerator rod must be disconnected before proceeding to step 4.3.

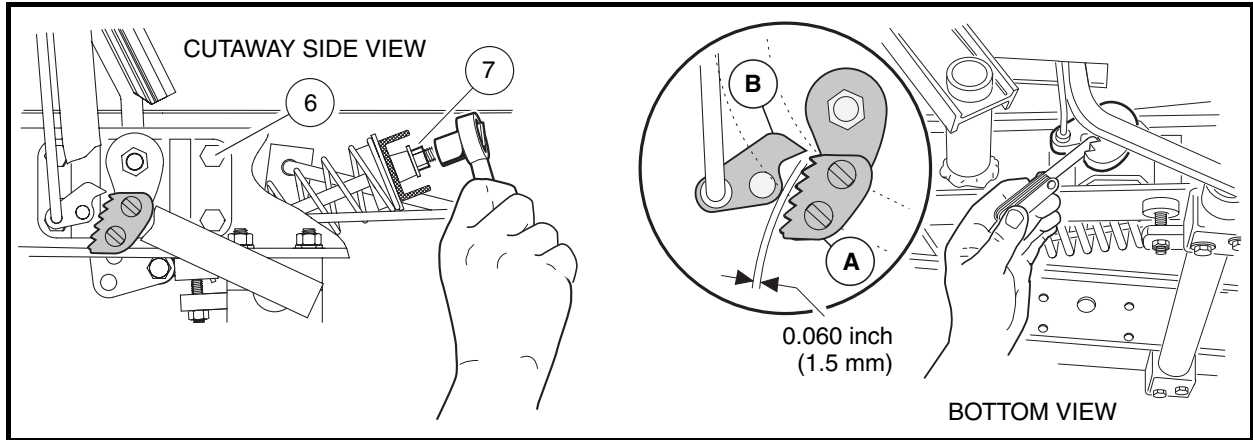

Figure 5-13 Park Brake Ratchet/Pawl Gap Adjustment

- 4.3. With the park brake unlocked, measure and note the distance from the top of the accelerator pedal to the floorboard, and then lock the park brake (Figure 5-14, Page 5-13).
- 4.4. With the park brake locked, make sure at least 75% of ratchet tooth length engages the pawl (Figure 5-15, Page 5-13). Tooth engagement should be between the two lines marked on the pawl.

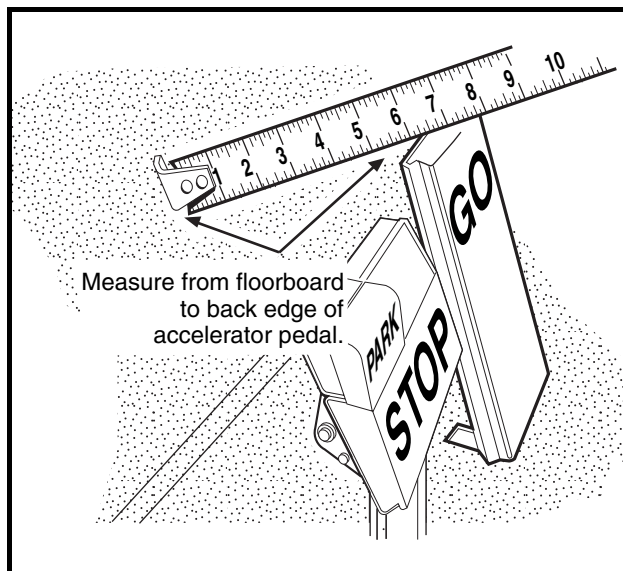

Figure 5-14 Accelerator Pedal Height Measurement

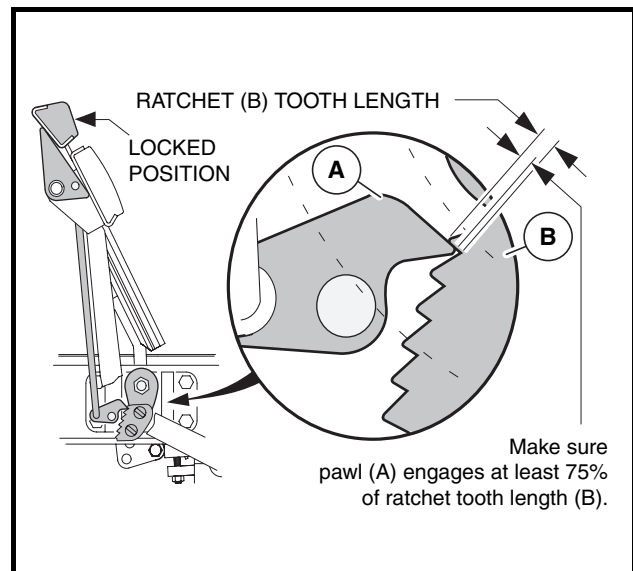

Figure 5-15 Ratchet/Pawl Tooth Engagement

- 4.5. With park brake still locked, measure the distance from the top of accelerator pedal to floorboard. If the measurement has changed, ratchet tooth engagement is too deep and must be adjusted.
- 4.6. If ratchet/pawl engagement must be adjusted, disconnect the ball joint at the top of the brake rod and rotate the ball joint sleeve clockwise to increase engagement or counterclockwise to decrease engagement. Reconnect ball joint (Figure 5-16, Page 5-14).
- 4.7. If the accelerator push rod was disconnected from the accelerator pedal, reconnect it.
- 4.8. Check for proper brake operation prior to driving the vehicle.

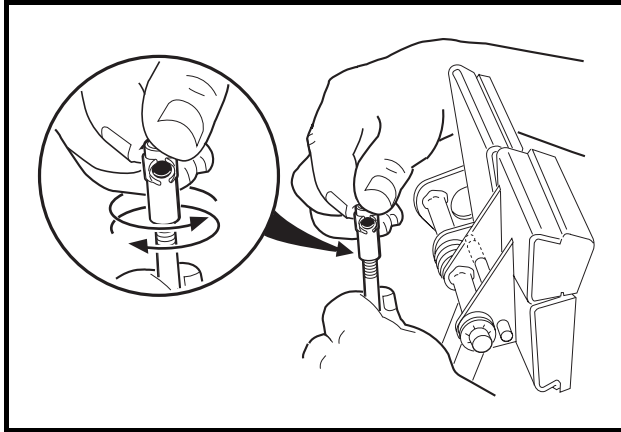

Figure 5-16 Brake Rod Adjustment

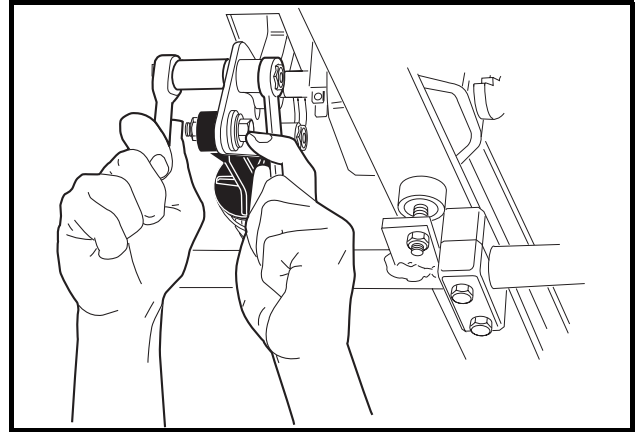

Figure 5-17 Accelerator Pedal Height Adjustment

5. Adjust accelerator pedal height.

- 5.1. Loosen the nut and bolt (Figure 5-17, Page 5-14) securing the accelerator pedal to the pivot plate.
- 5.2. Clamp the accelerator pedal adjustment tool (CCI P/N 101871001) to the accelerator pedal, with the end marked *accelerator pedal height* closest to the floorboard (Figure 5-18, Page 5-14). Press the accelerator pedal until the end of the tool rests against the floorboard; (pedal height should be 5-5/8 inches (14.3 cm)). Use a rubber strap to hold pedal in position against the floorboard and then tighten nut to 26 ft-lb (35.3 N·m).

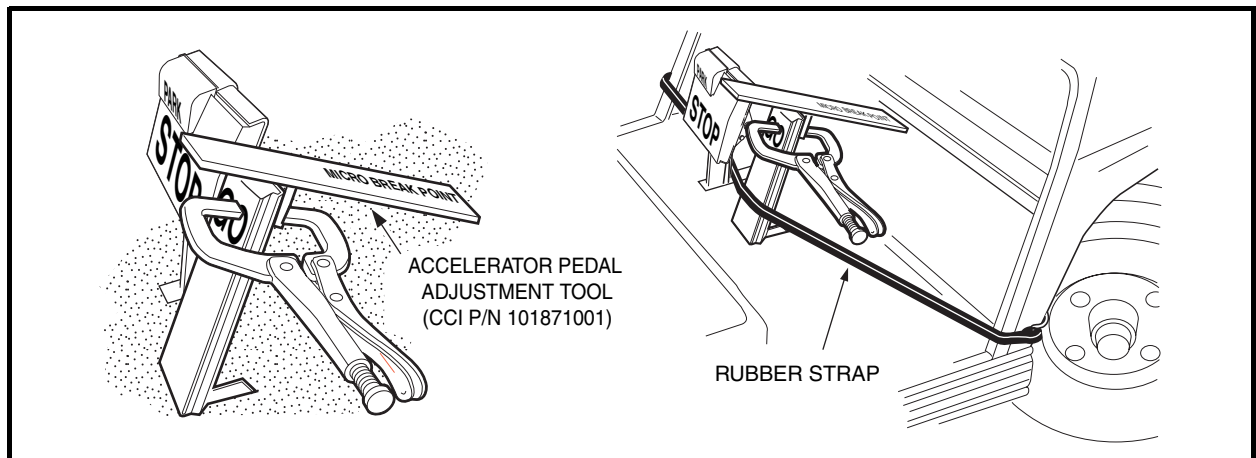

Figure 5-18 Accelerator Pedal Height Adjustment

6. Adjust the accelerator rod. **See following DANGER.**

⚠ DANGER

- Before servicing, turn the key switch to OFF and place the Forward/Reverse handle in the NEUTRAL position.
- To prevent accidentally starting the vehicle, disconnect the battery as instructed in WARNING “To avoid unintentionally starting...” in General Warning on page 1-2. This will prevent the possibility of the vehicle running over you when you are adjusting the accelerator rod.

- 6.1. Remove the electrical box screw and cover. **See preceding DANGER.**

- 6.2. Loosen the jam nuts (18) and disconnect the accelerator rod (17) at the accelerator pedal. Adjust the length of the rod (**Figure 5-5, Page 5-6**) to obtain an accelerator cable cam position of 14° as shown (**Figure 5-19, Page 5-15**). See following **CAUTION**.

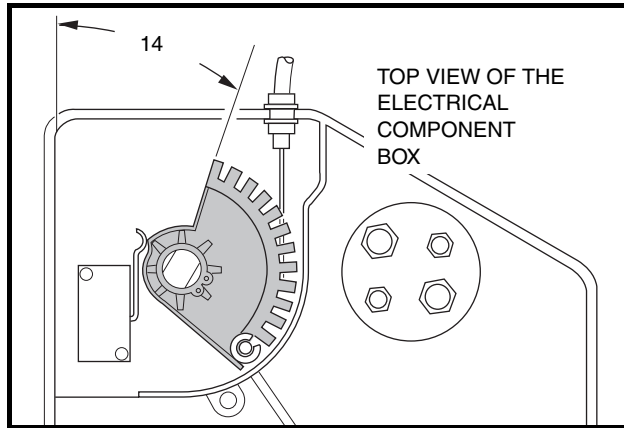

Figure 5-19 Accelerator Cable

⚠ CAUTION

- After accelerator rod adjustment, make sure that approximately the same number of threads are exposed at each end of the accelerator rod.
- If lever on the limit switch in the electrical box is bent, replace limit switch.
- When loosening jam nuts on the accelerator rod with one end disconnected, hold the disconnected accelerator rod with locking pliers.
- When tightening jam nuts on the accelerator rod, hold the disconnected ball joint with locking pliers.

- 6.3. Reconnect the accelerator rod at the accelerator pedal.
- 6.4. Before tightening jam nuts on accelerator rod, set park brake to first ratchet and pawl position. Press accelerator pedal and make sure the following events occur in the **exact order shown**:

EVENT	APPROXIMATE PEDAL TRAVEL
Park brake release	2° - 4°
Solenoid activation	4° - 8°
Carburetor throttle actuation	8° - 12°

- 6.5. If the events above occur as they should, hold the ball joint at each end of the accelerator rod with pliers and tighten the accelerator rod jam nut against it.
- 6.6. Ensure that the events occur as described in step 6.4 above. See following **NOTE**.

NOTE: After the accelerator pedal and rod are adjusted, the final governed engine RPM should be set at 3300 (± 30) RPM (800/810) or 2600 (± 30) RPM (850).

- 6.7. Install the electrical box cover and screw.

7. Adjust the brakes. See **Brake Adjustment, Section 6, Page 6-8**.

PEDAL GROUP ADJUSTMENT – ELECTRIC VEHICLES

See General Warning on page 1-1.

1. Disconnect the battery cables as instructed. See **WARNING “To avoid unintentionally starting...”** in General Warning on page 1-2.
2. Adjust brake pedal height.
 - 2.1. Chock wheels and release park brake. Lift rear of vehicle and place jack stands under the axle tubes to support the vehicle.
 - 2.2. To provide slack in the brake cables, loosen the equalizer retaining nuts (2 and 3) on the equalizer rods (1) (**Figure 5-20, Page 5-16**).

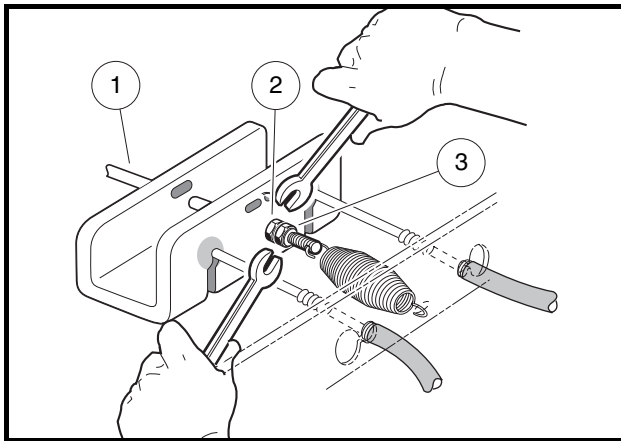

Figure 5-20 Loosen Rear Brake Equalizer Rod Nuts

- 2.3. Loosen the brake stop jam nut (31), then relieve pedal pressure on the stop by pushing down slightly on the pedal. Next, adjust the brake stop bumper (22) up or down (**Figure 5-21, Page 5-16**). Adjusting the bumper upward decreases distance between pedal and floorboard. Adjusting the bumper downward increases distance between pedal and floorboard. Proper brake pedal height is 6 inches (15.2 cm) (**Figure 5-22, Page 5-16**).
- 2.4. Tighten the jam nut (31) to 8 ft-lb (9.5 N·m) (**Figure 5-21, Page 5-16**).

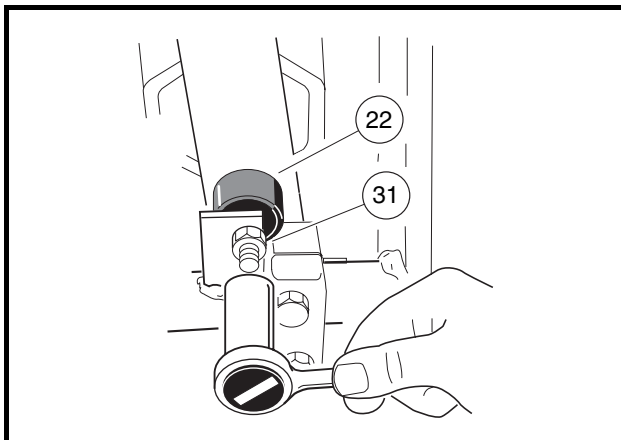

Figure 5-21 Brake Pedal Height Adjustment

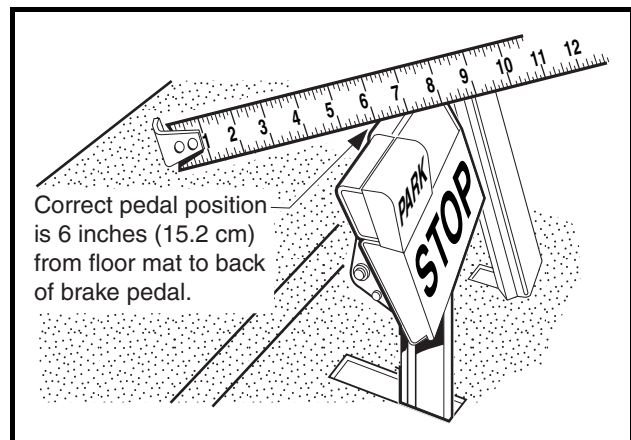

Figure 5-22 Brake Pedal Height Measurement

3. Adjust brake pedal free play. **See following NOTE.**

NOTE: Brake pedal free play is the distance the brake pedal can be pressed before the brake actuator arm (at the brake cluster) moves.

- 3.1. Measuring perpendicular from the floorboard to the back of the brake pedal, press the brake pedal and measure the distance that the pedal moves before all of the slack is taken out of the brake cables (**Figure 5-22, Page 5-16**).
- 3.2. Tighten the nut (2) on the equalizer rod (1) so that the brake pedal free play is 1/4 to 1/2 inch (6.3 to 12.7 mm) (**Figure 5-23, Page 5-17**).
- 3.3. Tighten the jam nut (3) while holding the adjustment nut (2) in the correct position (**Figure 5-23, Page 5-17**).

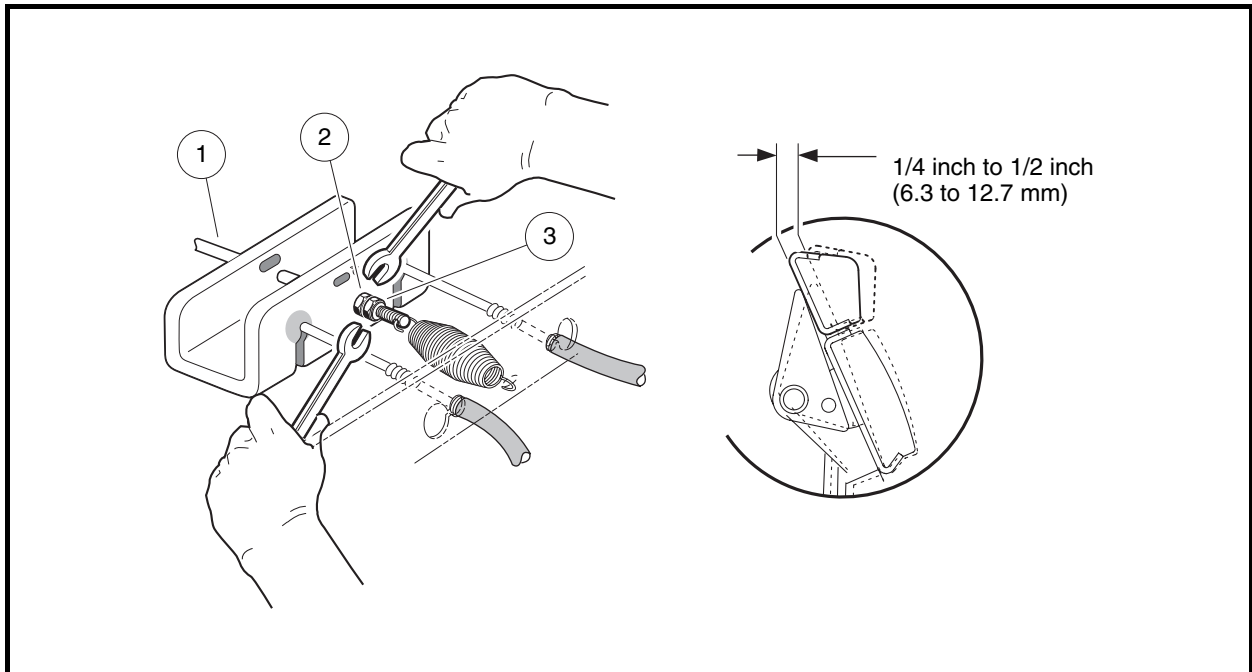

Figure 5-23 Brake Pedal Free-Play Adjustment

4. Adjust park brake ratchet/pawl gap and pawl engagement.

- 4.1. Inspect the park brake pawl and ratchet for excessive wear, grooves, cracks or chips. If either the pawl or ratchet is damaged, both must be replaced.
- 4.2. Adjust retaining nut (7) on spring support rod until there is a 0.060 inch (1.5 mm) gap between the pawl and the tips of the ratchet teeth. Use a feeler gauge to verify the gap (**Figure 5-24, Page 5-18**). The gap should be consistent through range of pawl movement. If the gap is not consistent, loosen the four bolts (6) securing the accelerator pivot rod supports and adjust the supports. If the gap becomes smaller as the park brake pedal is pressed, move the pivot rod supports slightly rearward until the gap is consistent. If the gap becomes larger as the park brake pedal is pressed, move the pivot rod supports slightly forward until gap is consistent.

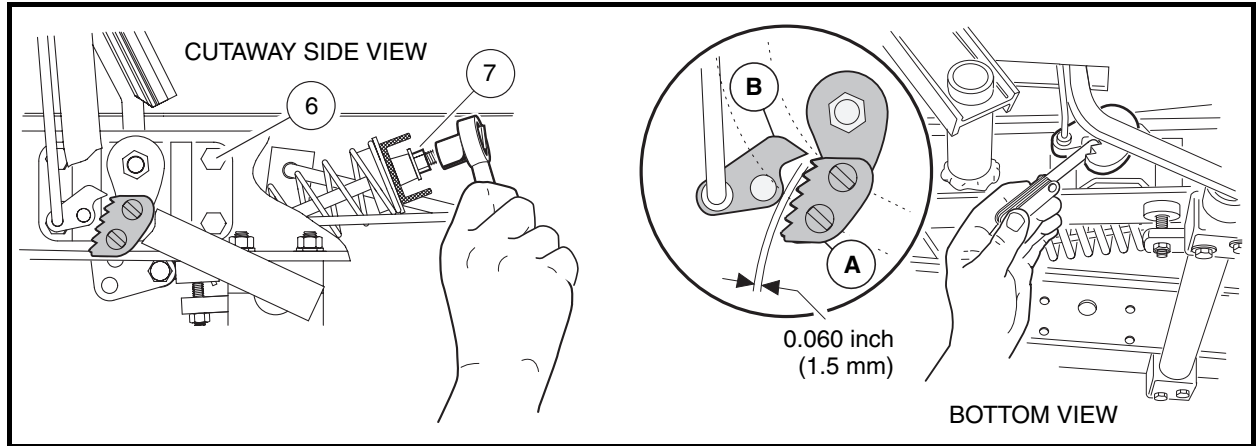

Figure 5-24 Park Brake Ratchet/Pawl Gap Adjustment

- 4.3. With the park brake unlocked, measure and note the distance from the top of the accelerator pedal to the floorboard, and then lock the park brake (**Figure 5-25, Page 5-18**).
- 4.4. With the park brake locked, make sure at least 75% of ratchet tooth length engages the pawl (**Figure 5-26, Page 5-18**). Tooth engagement should be between the two lines marked on the pawl.

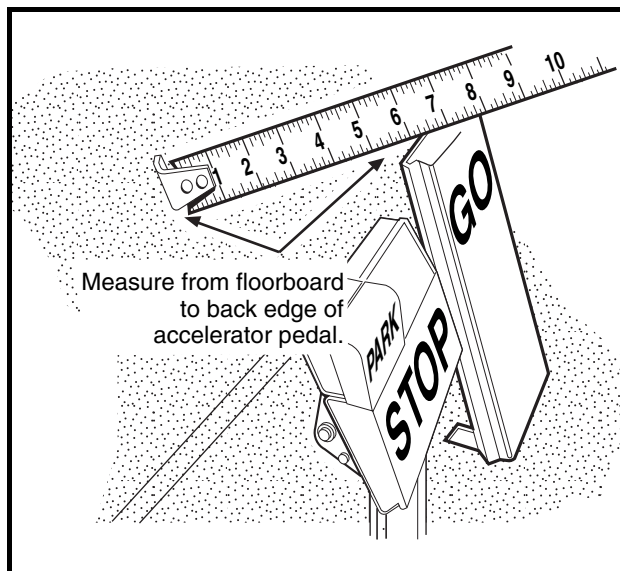

Figure 5-25 Accelerator Pedal Height Measurement

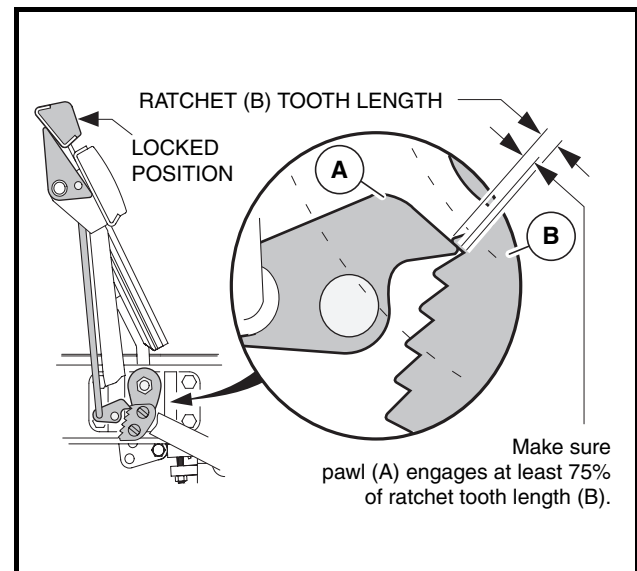

Figure 5-26 Ratchet/Pawl Tooth Engagement

- 4.5. With park brake still locked, measure the distance from the top of accelerator pedal to floorboard. If the measurement has changed, ratchet tooth engagement is too deep and must be adjusted.
- 4.6. If ratchet/pawl engagement must be adjusted, disconnect the ball joint at the top of the brake rod and rotate the ball joint sleeve clockwise to increase engagement or counterclockwise to decrease engagement. Reconnect ball joint (**Figure 5-27, Page 5-19**).
- 4.7. Check for proper brake operation prior to driving the vehicle.

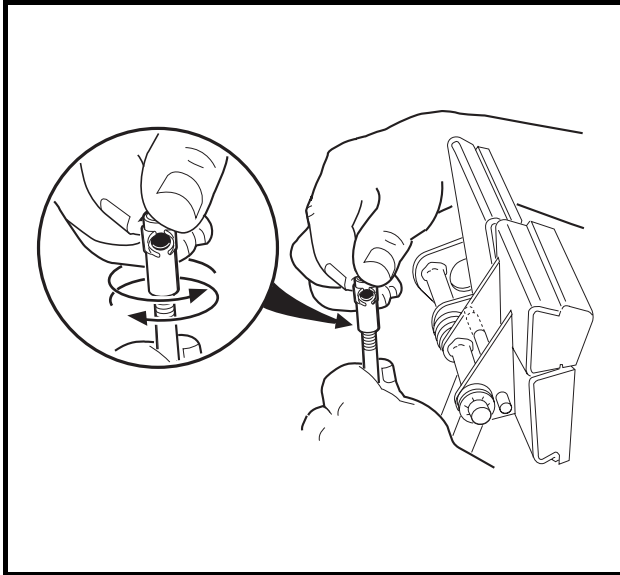

Figure 5-27 Brake Rod Adjustment

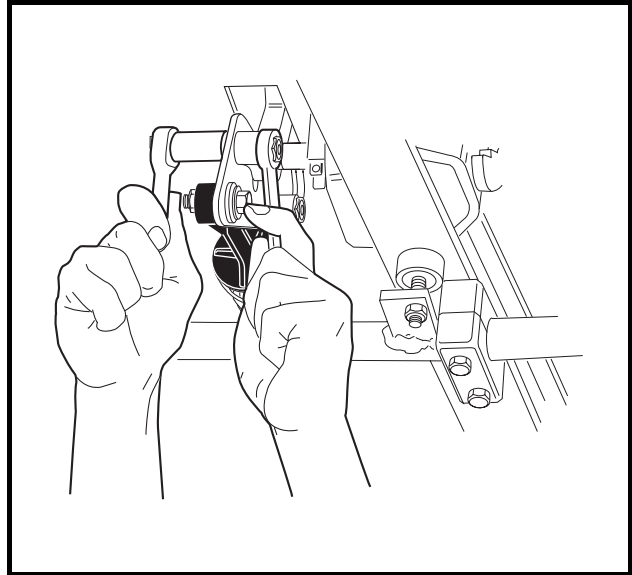

Figure 5-28 Accelerator Pedal Height Adjustment

5. Adjust accelerator pedal height.

- 5.1. Loosen the nut and bolt (**Figure 5-28, Page 5-19**) securing the accelerator pedal to the pivot plate.
- 5.2. Clamp the accelerator pedal adjustment tool (CCI P/N 101871001) to the accelerator pedal, with the end marked *accelerator pedal height* closest to the floorboard (**Figure 5-29, Page 5-19**). Press the accelerator pedal until the end of the tool rests against the floorboard; pedal height should be 5-5/8 inches (14.3 cm). Use a rubber strap to hold pedal in position against the floorboard and then tighten nut to 26 ft-lb (35.3 N·m).

6. Adjust the brakes. **See Brake Adjustment, Section 6, Page 6-8.**

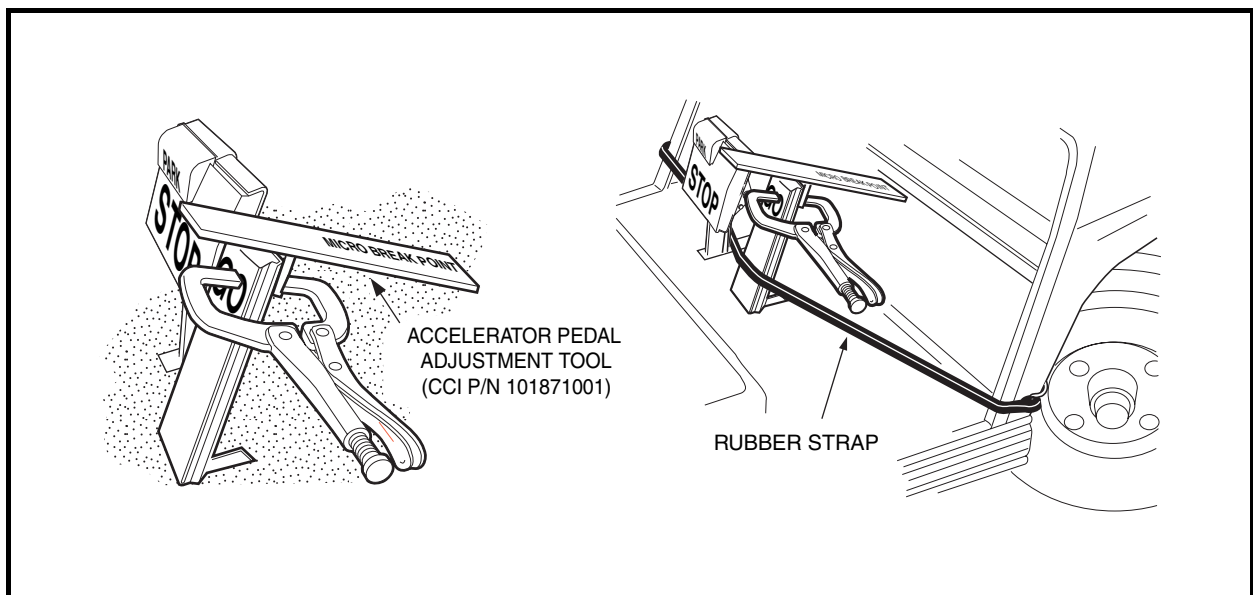

Figure 5-29 Accelerator Pedal Height Adjustment

SECTION 6 – WHEEL BRAKE ASSEMBLIES

⚠ DANGER

- See General Warning on page 1-1.

⚠ WARNING

- See General Warning on page 1-1.
- Some aftermarket brake shoes contain asbestos fiber, and asbestos dust is created when these brake mechanisms are handled. Wear approved eye and respiratory protection when disassembling and cleaning brake mechanisms. Inhalation of asbestos could result in severe personal injury or death. Do not use compressed air or aerosol sprays to clean the brake mechanism. Clean brake mechanism using the negative pressure enclosure/hepa vacuum system or low pressure/wet cleaning method per OSHA/29 CFR - 1910.1001.

BRAKE SHOE REMOVAL

See General Warning on page 1-1. See also Warning on Page 6-1.

1. Disconnect the battery cables as instructed. See **WARNING** “To avoid unintentionally starting...” in General Warning on page 1-2.
2. Place chocks at the front wheels. Loosen, but do not remove lug nuts on rear wheels and lift the rear of the vehicle with a chain hoist or floor jack. Place jack stands under the axle tubes to support the vehicle.
3. Loosen the equalizer retaining nuts (2 and 3) on the equalizer rod (1) to loosen the brake cable (Figure 6-1, Page 6-2).
4. Remove the rear wheels and then the brake drums. If the brake drums were easily removed, proceed to step 6. See following **CAUTION** and **NOTE**.

⚠ CAUTION

- Worn or damaged brake drums cannot be machined to refinish them. Replace as necessary.

NOTE: When servicing vehicles with severely worn brake shoes and when the drums cannot be removed by normal methods, proceed to step 5 to minimize damage to the brake cluster and brake components.

5. Remove brake drums and badly worn brake shoes.
 - 5.1. On the back of each brake cluster assembly, locate the heads of two brake shoe retainer pins. It may be necessary to remove sealant material around the head of each pin.

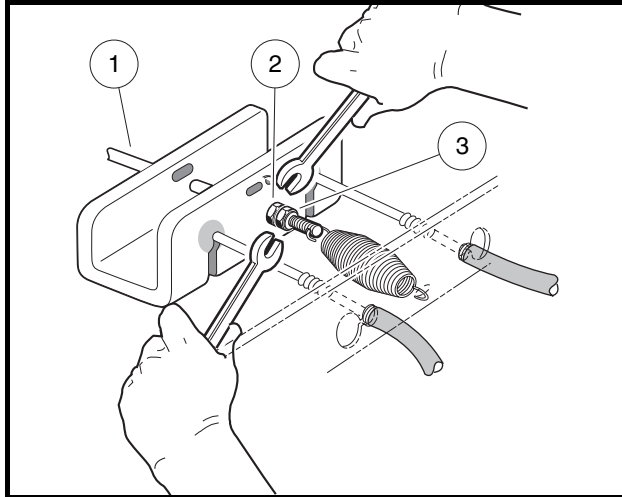

Figure 6-1 Loosen Equalizer Retaining Nuts

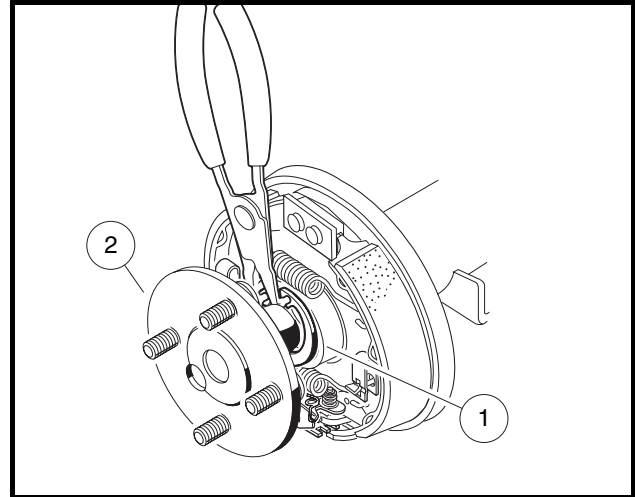

Figure 6-2 Remove Axle Retaining Ring

5.2. Insert a 1/2 inch x 5/8 inch cold chisel under the head of each pin and shear them off as illustrated (**Figure 6-3, Page 6-2**). This will release the shoes from the backing plate, allowing them to pivot away from the inside of the brake drum, which should then allow the brake drum to be pulled free. After completing step 6, skip step 7. **See following NOTE.**

NOTE: Although step 6 allows easier access to the brake shoes, it is not imperative to do so in order to remove the brake shoes.

6. Remove the axle.

- 6.1. Using 90° snap ring pliers (CCI P/N 1012560), remove the axle retaining ring (1) (**Figure 6-2, Page 6-2**).
- 6.2. Pull the axle shaft (2) from the axle tube (**Figure 6-2, Page 6-2**).

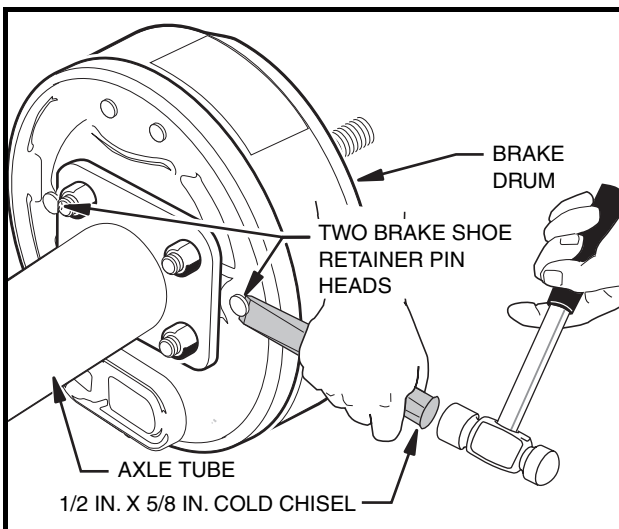

Figure 6-3 Shoe Retainer Pins

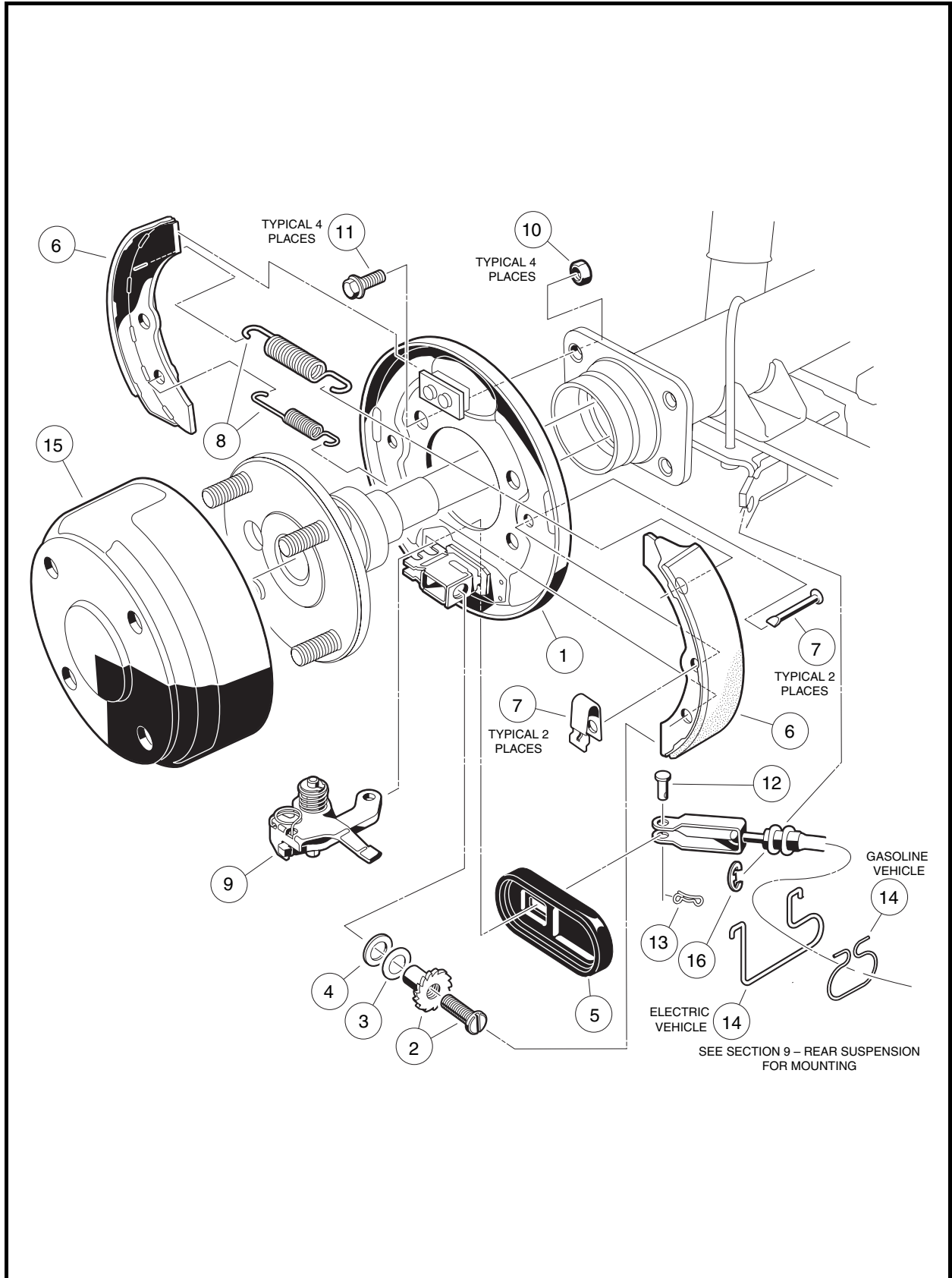

Figure 6-4 Self-adjusting Wheel Brake Assembly

- Using needle nose pliers, turn the clip retainer pin (1) 90° to remove the shoe retainer clip (2) (Figure 6-5, Page 6-4). See following CAUTION.

⚠ CAUTION

- The brake shoes are under pressure and can release suddenly when brake shoe retainers are removed.
- Grasp both brake shoes and pull them, together with the springs, out of the brake assembly as shown (Figure 6-6, Page 6-4).

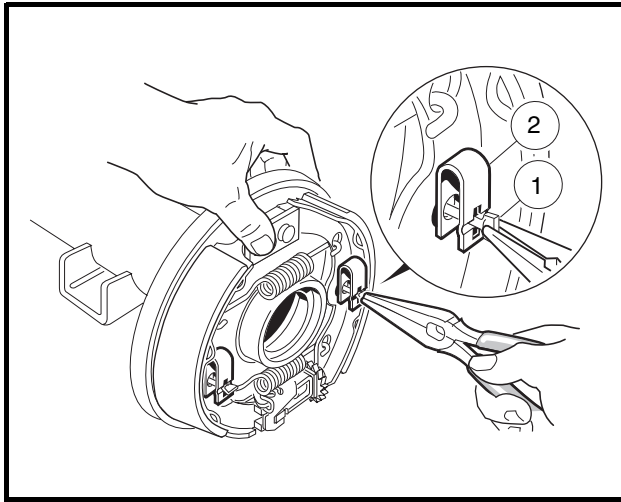

Figure 6-5 Remove Shoe Retainer Clip

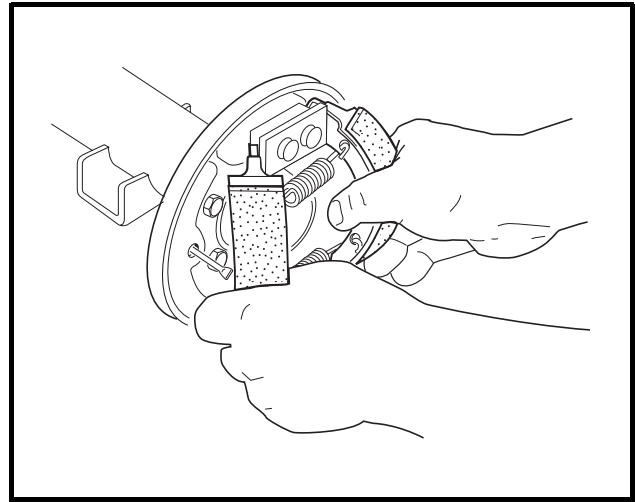

Figure 6-6 Remove Brake Shoes

- Remove adjuster wheel (1) with two washers (2 and 3) from the backing plate (Figure 6-7, Page 6-4).

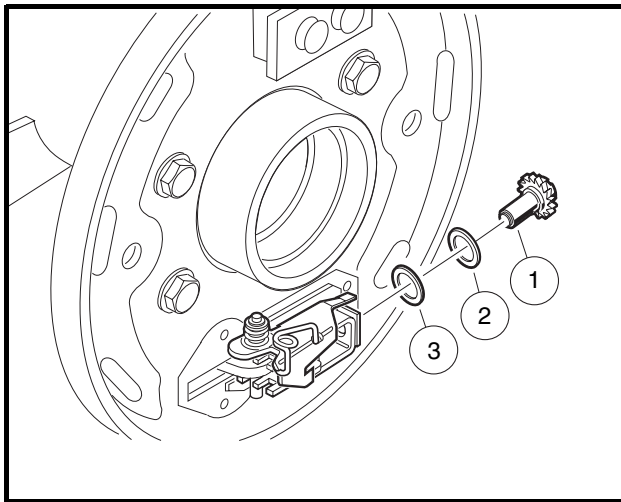

Figure 6-7 Remove Adjuster Wheel

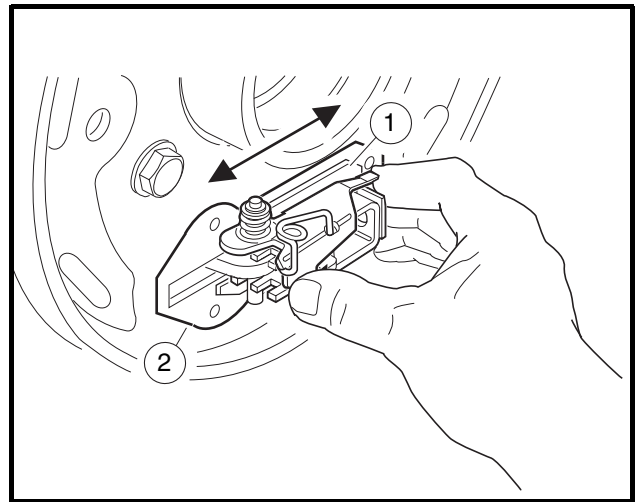

Figure 6-8 Lubricate Slide and Slide Plate

BRAKE ASSEMBLY CLEANING

See General Warning on page 1-1. See also Warning on Page 6-1.

1. Carefully clean the brake backing plate and all of its mechanical components.
2. Remove the rubber boot from backing plate and wipe with a clean damp cloth.
3. Lubricate the slide (1) and slide plate (2) with dry moly lubricant (CCI P/N 1012151) on both sides of the backing plate (**Figure 6-8, Page 6-4**). After lubricating, work the slide back and forth to ensure that it slides smoothly and easily. Reinstall rubber boot onto backing plate. **See following WARNING.**

⚠ WARNING

- **Apply grease carefully when performing the following steps. Do not allow any grease to get onto the friction surfaces of the brake shoe pads. Failure to heed this warning could cause diminished brake performance, possibly resulting in property damage or severe personal injury.**
4. Use a small brush to carefully apply a light coat of white lithium NLGI #2 grease (Dow Corning BR2-Plus or equivalent) on each of the six raised bosses on the brake backing plate (**Figure 6-9, Page 6-5**). **See preceding WARNING.**
 5. Use a small brush to carefully apply a light coat of white lithium NLGI #2 grease (Dow Corning BR2-Plus or equivalent) to each end of both brake shoes and into the slots in the brake shoe mounting block as shown (**Figure 6-10, Page 6-5**). **See preceding WARNING.**

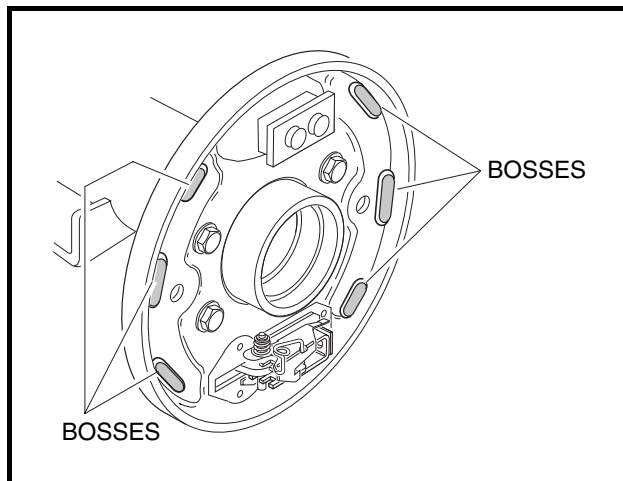

Figure 6-9 Apply Grease On Bosses

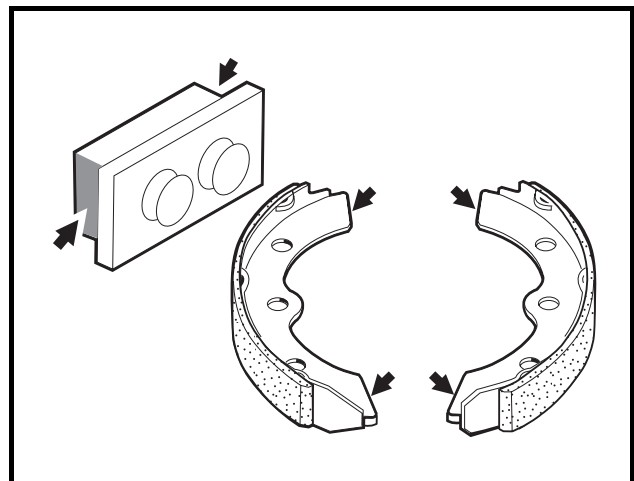

Figure 6-10 Apply Grease To Brake Shoes and Slots

6. Use a small brush to carefully apply a light coat of white lithium NLGI #2 grease (Dow Corning BR2-Plus or equivalent) to the brake adjuster assembly, adjuster wheel shoe slots, and the shaft of the adjuster wheel as shown (**Figure 6-11, Page 6-6**). **See preceding WARNING.**
7. Install the adjuster wheel (1) and two washers (2 and 3) into the adjuster assembly (**Figure 6-7, Page 6-4**).

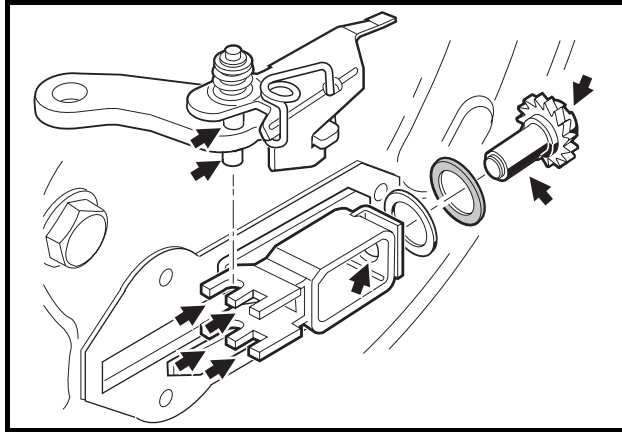

Figure 6-11 Apply Grease To Brake Adjuster

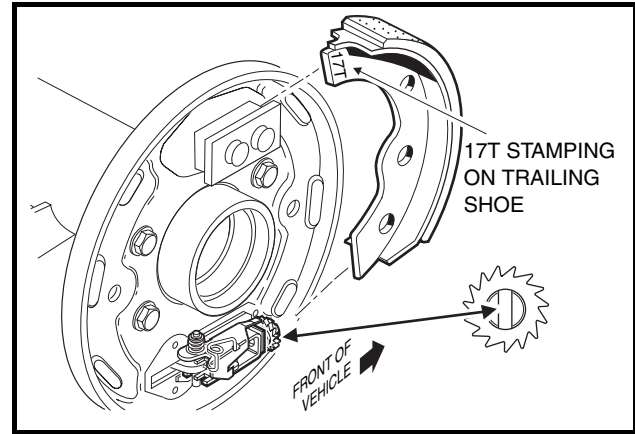

Figure 6-12 Install Adjuster Wheel, Trailing Shoe

BRAKE SHOE INSTALLATION

See General Warning on page 1-1. See also Warning on Page 6-1.

1. Turn the adjusting wheel screw so that the shoe slot is vertical, then position the trailing shoe in the slots in the shoe mounting block and adjuster assembly (Figure 6-12, Page 6-6). See following NOTE.

NOTE: The trailing shoe has 17T stamped into the tip of the shoe flange (Figure 6-12, Page 6-6). The leading shoe is stamped 17L. When installing the shoes, the stamping on both shoes should be oriented to the top of the brake assembly. When installing the shoes on the passenger side of the vehicle, the side of the trailing shoe flange marked 17T should be facing out and be visible. On the driver side, the 17L on the leading shoe should be facing out and be visible.

When installed on the backing plate, the **leading shoe** (stamped 17L) is **always** oriented toward the **rear** of the vehicle.

2. Install the shoe retainer clip, using pliers to compress the clip (1) while turning the retainer pin (2) into position (Figure 6-13, Page 6-6).
3. Attach the springs onto the trailing shoe already installed. Then hold the leading shoe next to the trailing shoe, correctly oriented, and attach the springs to it (Figure 6-14, Page 6-6).

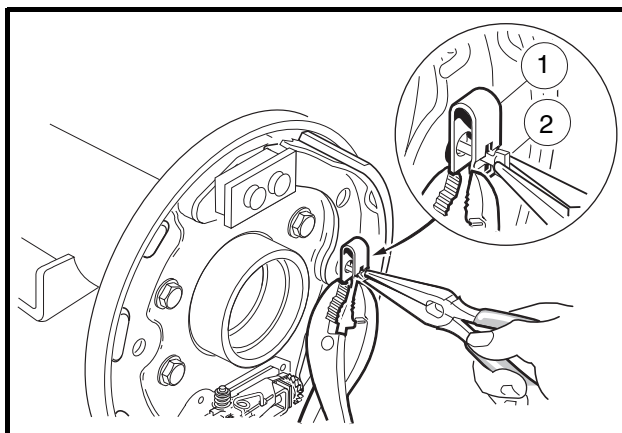

Figure 6-13 Install Trailing Shoe Retainer Clip

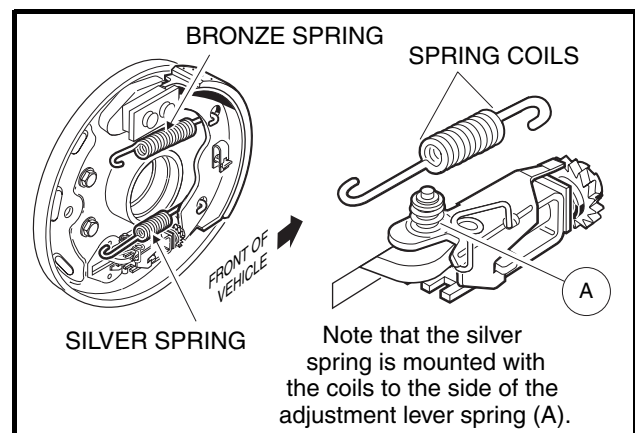

Figure 6-14 Attach Springs

4. While maintaining spring attachment on both shoes, position tips of leading shoe in the mounting slots and then push shoe into place. Hold shoe in position and install retaining clip (**Figure 6-15, Page 6-7**).
5. After the shoes are installed, move them together up and down and side to side to make sure that they will easily slide approximately 1/4 to 3/8 inch (6.3 to 9.5 mm) without binding (**Figure 6-16, Page 6-7**).

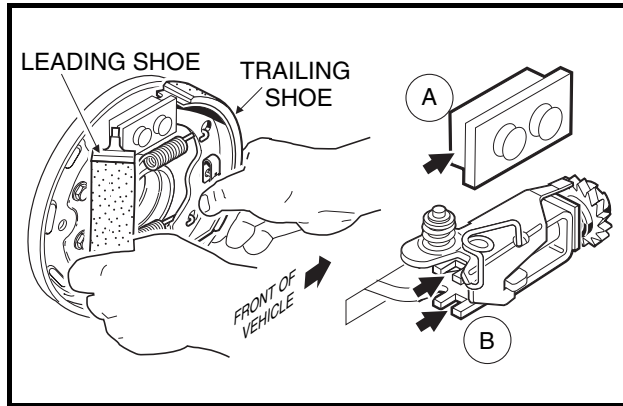

Figure 6-15 Install Leading Shoe

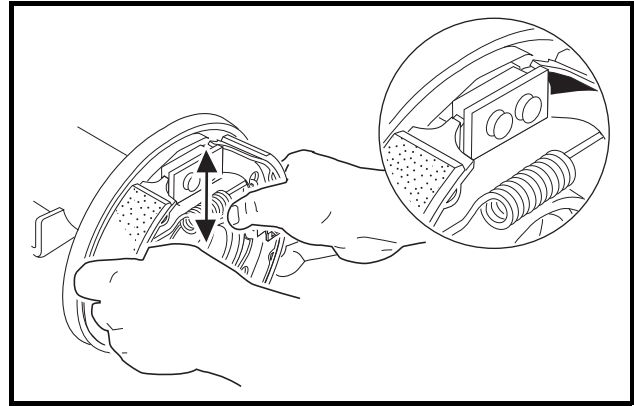

Figure 6-16 Check Shoe Positions

6. Place a flatblade screwdriver under the adjusting arm and raise the arm off of the adjusting wheel. While holding the arm up, turn the wheel upward until it stops (**Figure 6-17, Page 6-7**). Remove the screwdriver.

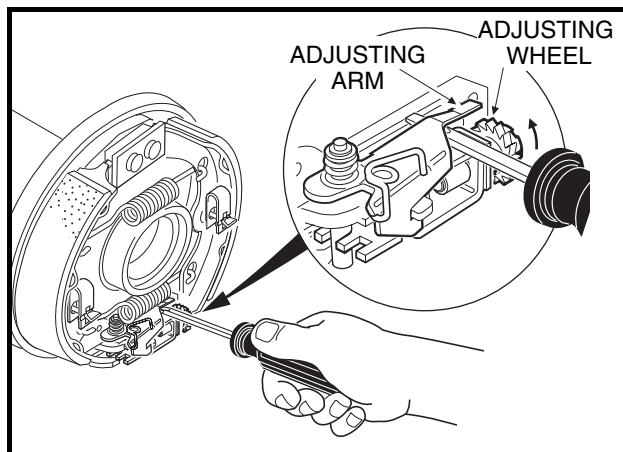

Figure 6-17 Set Adjusting Wheel

7. Install the axle shaft (2) into the axle tube and install the retaining ring (1) (**Figure 6-2, Page 6-2**). See following **WARNING** and **CAUTION**.

⚠ WARNING

- Be sure retaining ring is properly seated in groove. If ring is not properly installed, the axle assembly will separate from the transaxle and damage the axle assembly and other components. Loss of control of the vehicle could result in severe personal injury or death.

⚠ CAUTION

- **Before installing axle shaft, clean any residual oil from the exposed end of the axle tube and from the oil seal area.**
8. Install the brake drum, and make sure that it is properly seated. **See following NOTE.**
- NOTE:** *If drum installation is difficult, the brake shoes may need to be adjusted vertically in the mounting slots.*
9. After the drum is installed, make sure the axle and drum turn freely and then install the wheel. **See Wheel Installation, Section 8, Page 8-1.**

BRAKE ADJUSTMENT

See General Warning on page 1-1. See also Warning on Page 6-1.

1. When cleaning or repair on both wheels is complete, and with the brake cable still loose, lower the vehicle to the floor.
2. Make the brake shoe and drum adjustment by pressing and releasing the brake pedal repeatedly until an audible clicking can no longer be heard.
3. Adjust brake pedal free play.
 - **For gasoline vehicles: See Pedal Group Adjustment – Gasoline Vehicle, Section 5, Page 5-11.**
 - **For electric vehicles: See Pedal Group Adjustment – Electric Vehicles, Section 5, Page 5-16.**

BRAKE CLUSTER REMOVAL AND INSTALLATION

See General Warning on page 1-1. See also Warning on Page 6-1.

Brake Cluster Removal

1. Disconnect the battery cables as instructed. **See WARNING “To avoid unintentionally starting...” in General Warning on page 1-2.**
2. Place chocks at the front wheels and loosen the lug nuts on the rear wheels. Lift the rear of the vehicle with a chain hoist or floor jack. Place jack stands under the axle tubes to support the vehicle. **See General Warning, Section 1, Page 1-1.**
3. Loosen the equalizer retaining nuts (2 and 3) on the equalizer rod (1) to loosen the brake cable (**Figure 6-1, Page 6-2**).
4. Remove lug nuts and rear wheels and then the brake drums. **See following NOTE.**

NOTE: *When servicing vehicles with self-adjusting brakes with badly worn brake shoes and when the drums cannot be removed by normal methods, perform Step 5 of Brake Shoe Removal on page 6-1, then continue with this procedure.*

*Although step 5 – **Removing the Axle** allows easier access to the brake shoes, it is not imperative to do so in order to remove the brake shoes.*

5. Remove the axle.

- 5.1. Using 90° snap ring pliers (CCI P/N 1012560), remove the axle retaining ring (1) (**Figure 6-2, Page 6-2**).
- 5.2. Pull the axle shaft (2) from the axle tube (**Figure 6-2, Page 6-2**).
6. Remove bow-tie pin (13) and clevis pin (12) from brake cable (**Figure 6-4, Page 6-3**).
7. Remove four bolts (11) and lock nuts (10) that mount the brake assembly to the transaxle (**Figure 6-4, Page 6-3**).
8. Remove brake assembly from transaxle.

BRAKE CLUSTER INSTALLATION

1. Install in reverse order of disassembly. Use new bow-tie pins when installing brake cables. **See following CAUTION.**

⚠ CAUTION

- **Before installing axle shaft, clean any residual oil from the exposed end of the axle tube and from the oil seal area.**
2. Be sure bolts (11) (CCI P/N 1014153) and new lock nuts (10) (CCI P/N 1013924) are used to mount the brake assembly (**Figure 6-4, Page 6-3**).
 3. Tighten nuts to 17 ft-lb (23.0 N·m). If torquing the bolt heads, torque to 30 ft-lb (40.6 N·m).
 4. Install the rear axle onto the transaxle.
 - 4.1. Insert the splined end of the axle shaft into the axle tube. Be careful not to damage the seal on the inside of the axle tube hub. Advance the shaft through to the bearing on the shaft, and rotate it to align the shaft splines with the splined bore of the differential gear. Continue advancing the shaft until the bearing on the axle is firmly seated within the axle tube hub seal.
 - 4.2. Use a 90° internal snap ring pliers (.090 tip) to attach the internal retaining ring into the axle tube hub so that it seats against the axle bearing assembly and into the machined slot in the inside wall of the axle tube hub.
 - 4.3. Place a 1/4 to 3/8 - inch (6 - 10 mm) diameter rod against the retaining ring and tap lightly at four or five locations to ensure it is properly seated. **See following WARNING.**

⚠ WARNING

- **Be sure retaining ring is properly seated in groove. If ring is not properly installed, the axle assembly will separate from the transaxle and damage the axle assembly and other components. Loss of control of the vehicle could result in severe personal injury or death.**
5. Tighten lug nuts on rear wheels, using crisscross pattern, to 55 ft-lb (74.6 N·m). **See Wheel Installation, Section 8, Page 8-1.**
 6. Adjust the brakes. **See Brake Adjustment on page 6-8.**

BRAKE CABLE REMOVAL AND INSTALLATION

See **General Warning** on page 1-1. See also **Warning** on Page 6-1.

Brake Cable Removal

1. Disconnect the battery cables as instructed. See **WARNING “To avoid unintentionally starting...”** in **General Warning** on page 1-2.
2. Place chocks at the front wheels.
3. Release the park brake if engaged and loosen equalizer retaining nuts (1) on equalizer rod (2) to slightly loosen the brake cables (3) (**Figure 6-18, Page 6-10**).

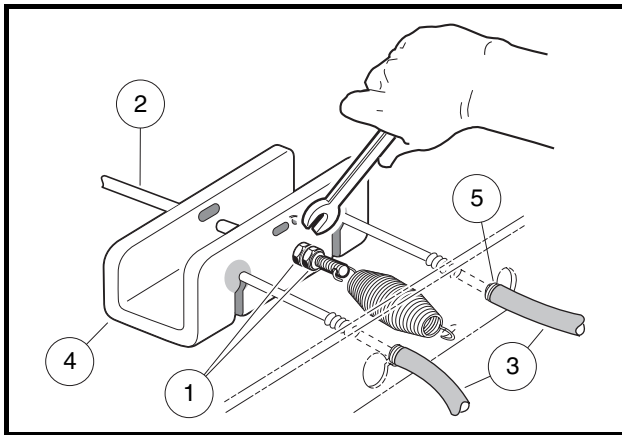

Figure 6-18 Loosen Brake Cables

4. Rotate the brake cable upward and pull cable end through hole in top of equalizer (4).
5. Remove E-clip from cable at vehicle frame (5) (**Figure 6-18, Page 6-10**). Remove cable from frame.
6. Remove bow-tie pin (1) and the clevis pin (2) from the brake lever on each wheel and pull the clevis (3) away from the lever. (**Figure 6-19, Page 6-10**).
7. Remove E-clip (4) from cable at the cable support bracket (5). Remove cable from bracket.

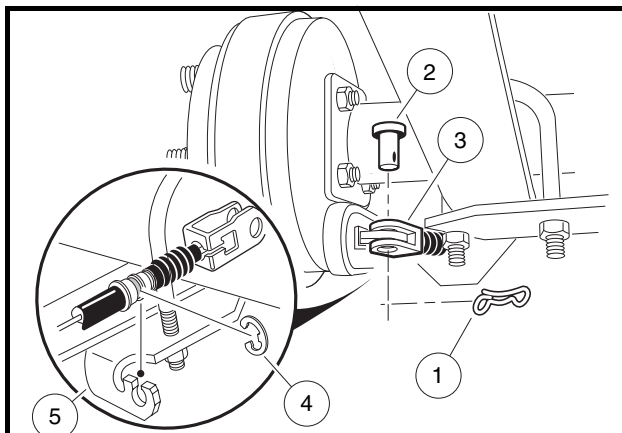

Figure 6-19 Disconnect Cables at Rear Brakes

For Vehicles with Clip:

8. Locate the brake cable hanger clip (1), if equipped, on the frame and remove it from the vehicle (**Figure 6-20, Page 6-12**). Discard the clip.
9. Remove the forward leaf spring mounting bolt (3/8-16 x 3-3/8-inch) (5) and 3/8-16 nylon locknut (6). Discard the mounting bolt.

For Vehicles with P-Clamp:

10. Remove the 3/8-16 nylon locknut (6) and p-clamp (2) that secure the brake cable (3) to the frame.
11. If replacing brake cable, remove the p-clamp (2) from the brake cable (3) and retain for installation of new cable.

For All Vehicles:

12. Note routing of cable through hanger for installation of new cable. Pull cable from vehicle.

Brake Cable Installation

1. Place the end of the new cable into the equalizer (4) (**Figure 6-18, Page 6-10**). Secure the cable to the vehicle frame with new E-clip. Route cable through hanger in the same manner as before.
2. At the rear wheel brake, connect the cable to the brake actuator arm using new clevis pin (2) and new bow-tie pin (1) (**Figure 6-19, Page 6-10**).
3. Place the cable in the cable support bracket (5) and secure with new E-clip (3).

For Vehicles Originally Equipped With Clip:

4. Insert a new 3/8-16 x 3-1/2-inch hex-head bolt (5) through the leaf spring mount and leaf spring (**Figure 6-20, Page 6-12**).

For All Vehicles:

5. Install the brake cable p-clamp (2) over the smaller diameter portion of the brake cable (3) so that the flat face of the p-clamp is oriented to the inboard side of the leaf spring mount (4) on the frame.
6. Secure the brake cable p-clamp (2) to the leaf spring mounting bolt (5) finger-tight with the 3/8-16 nylon locknut (6). **See following NOTE.**

NOTE: Make sure there is a 1/8-3/16-inch clearance between the tire and the brake cable. If clearance is not adequate, slide the brake cable forward inside the p-clamp until the correct clearance is obtained.

7. Tighten the locknut (6) to 15 ft-lb (20.3 N·m). Do not allow the p-clamp to rotate while tightening the hardware.
8. Adjust the brakes. **See Brake Adjustment on page 6-8.**

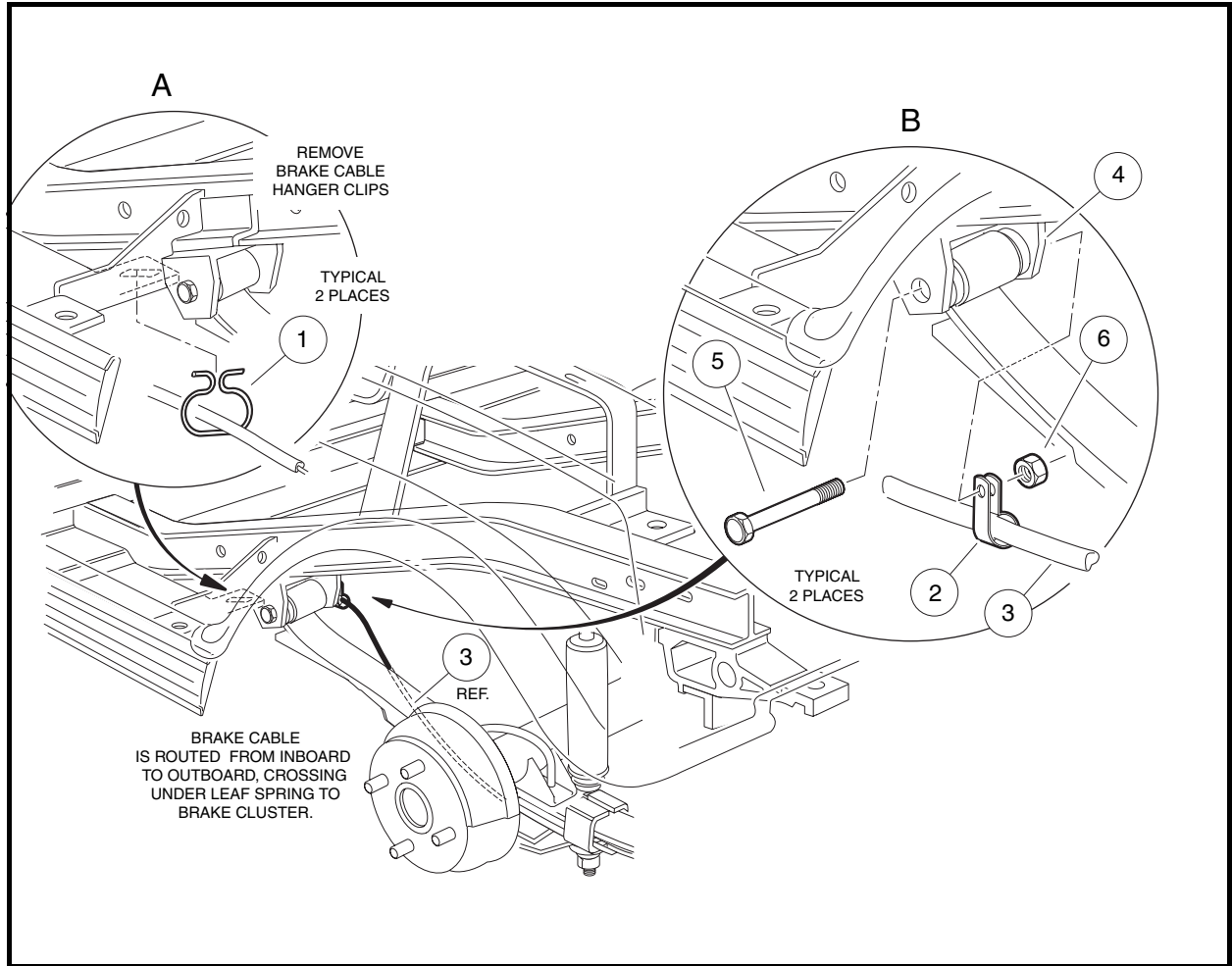

Figure 6-20 Brake Cable Clip and P-Clamp

SECTION 7 – STEERING AND FRONT SUSPENSION

▲ DANGER

- See General Warning on page 1-1.

▲ WARNING

- See General Warning on page 1-1.

GENERAL INFORMATION

Steering is controlled through a rack and pinion steering assembly that is connected by a steering column to a steering wheel. No manual adjustment to the rack and pinion gear assembly is required. A spring loaded self-adjusting mechanism is incorporated into the assembly.

STEERING WHEEL

See General Warning on page 1-1.

STEERING WHEEL REMOVAL

1. Disconnect the battery cables as instructed. **See WARNING “To avoid unintentionally starting...” in General Warning on page 1-2.**
2. Remove the plate (28) (**Figure 7-3, Page 7-3**).
3. Match mark the steering wheel (25) and steering shaft (19) so when the steering wheel is removed it can be placed back in exactly the same position on steering column shaft.
4. Loosen the steering wheel nut (27) and back it off approximately 1/4 inch (6 mm). Do not remove the nut.
5. Use the steering wheel puller (CCI P/N 102061201) to remove steering wheel.
 - 5.1. Place the puller anvil (4) through the top opening of the steering wheel (**Figure 7-1, Page 7-2**).
 - 5.2. Insert the anvil feet through the two slots in the base plate (marked “B”) (5) as shown (**Figure 7-1, Page 7-2**).
 - 5.3. Rotate the anvil screw (6) clockwise until the base plate contacts the bottom of the steering wheel where it attaches to the steering column (**Figure 7-2, Page 7-2**).
 - 5.4. Using a 1/2 inch drive air impact wrench, tighten the anvil screw (6) until the steering wheel breaks free from the steering shaft.
 - 5.5. Remove the steering wheel puller.
 - 5.6. Remove the steering wheel nut (27) and the steering wheel (25) from the steering column (20) (**Figure 7-3, Page 7-3**).

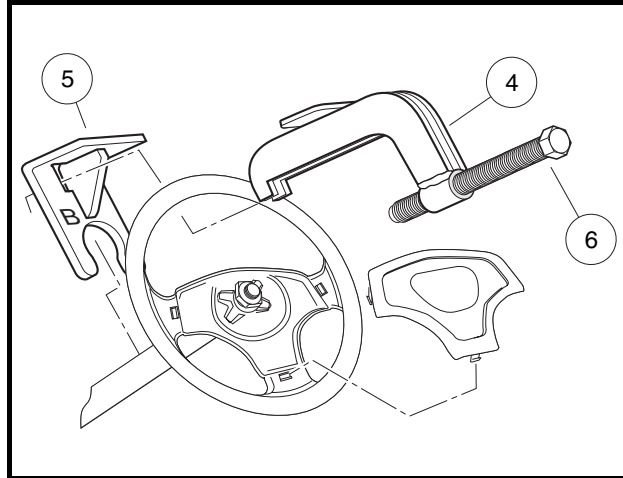

Figure 7-1 Steering Wheel Puller

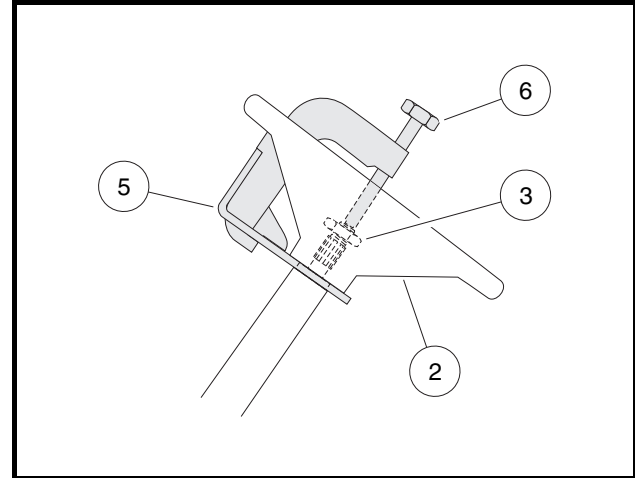

Figure 7-2 Steering Wheel Puller

STEERING WHEEL INSTALLATION

NOTE: To minimize corrosion and to make future removal of the steering wheel easier, apply a small amount of oil or anti-seize compound to steering shaft splines and taper before installing the steering wheel.

1. Install the steering wheel (25) on the splines of the steering shaft (19). Be sure to align the match marks placed on the wheel and steering column in step 3 above (**Figure 7-3, Page 7-3**).
2. Install the steering wheel nut (27) and tighten to 13 ft-lb (17.6 N·m).
3. Install the plate (28) (**Figure 7-3, Page 7-3**).

STEERING COLUMN

See General Warning on page 1-1.

STEERING COLUMN REMOVAL

1. Disconnect the battery cables as instructed. See **WARNING “To avoid unintentionally starting...”** in **General Warning on page 1-2**.
2. Remove the steering wheel. See **Steering Wheel Removal on page 7-1**.
3. Remove the front body as instructed in Section 4 – Body and Trim.
4. Remove the instrument panel.
 - 4.1. Remove the plastic panel screws from the instrument panel.
 - 4.2. Pull dash panel from the dash.
 - 4.3. Disconnect the wires from the electrical components mounted on the dash panel. Do not allow wires to touch.
 - 4.4. Slide dash panel up and away from the steering column.

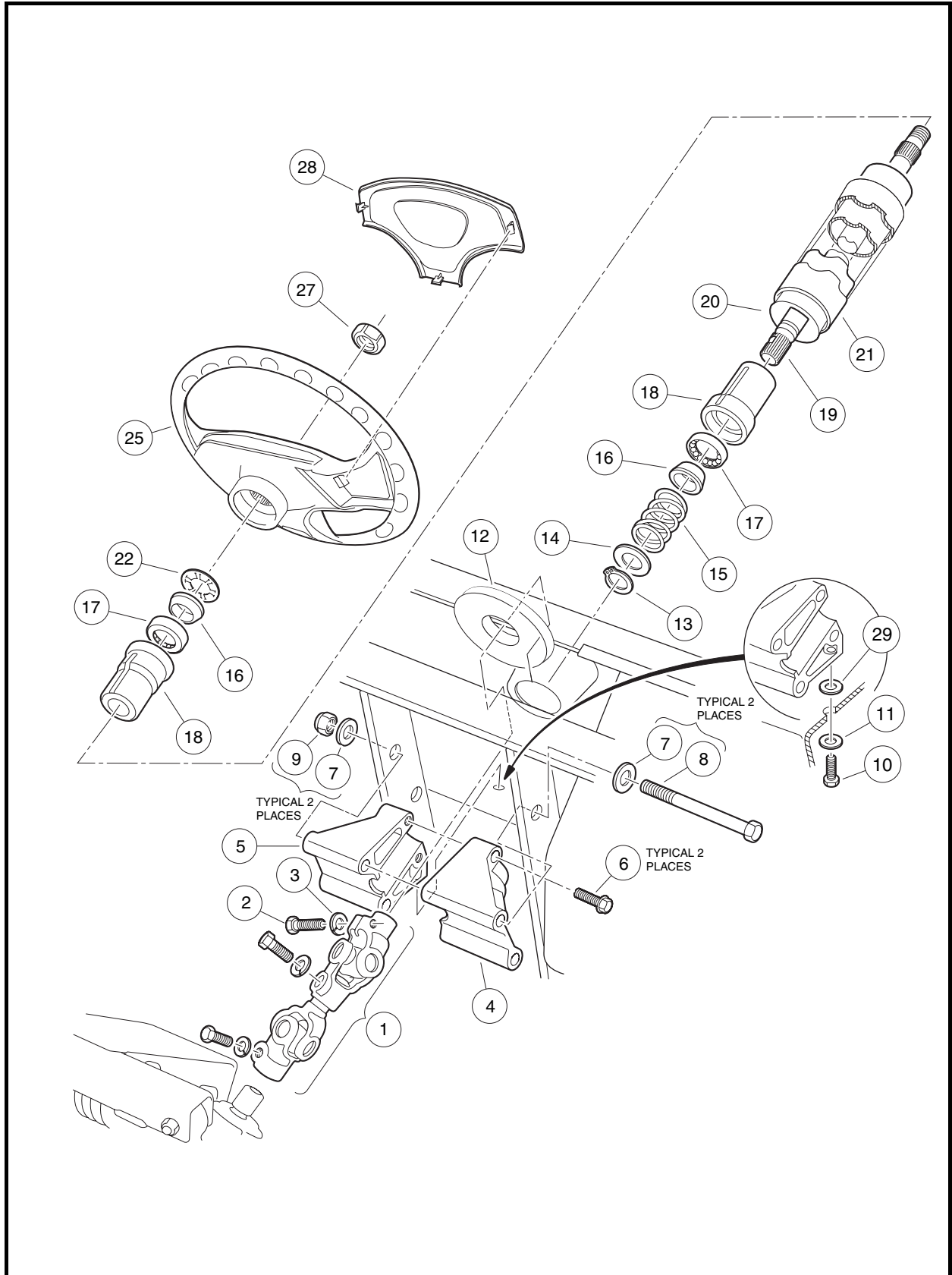

Figure 7-3 Steering Column

5. Remove the dash. **See Molded Dash Removal, Section 4, Page 4-4.**
6. Remove the upper bolt (2) and lock washer (3) from the universal joint (**Figure 7-3, Page 7-3**).
7. Remove the nuts (9), bolts (8 and 10), and washers (7 and 11) from the steering column mount (4 and 5).
8. Remove the steering column from the vehicle.

STEERING COLUMN DISASSEMBLY

1. Remove screws (6) and mount (4 and 5) from steering column. Remove boot (12) (**Figure 7-3, Page 7-3**).
2. While supporting steering column (21) on a workbench, remove snap ring (13) from shaft. **See following NOTE.**

NOTE: Do not allow the steering shaft to slide out of the steering tube when removing the snap ring.

3. Remove the washer (14), spring (15) and wedge (16). **See following NOTE.**

NOTE: Use a new seal, retaining rings and new bearings for reassembly.

4. Slide the shaft out of the tube to expose the retaining ring (22). Use pliers to twist the retaining ring (22) until it breaks off, then remove the wedge (16).
5. Remove the shaft (19) from the bottom of the tube (20).
6. Use steering shaft (19) to push bearing seat (18) out from the opposite end of the steering tube (20).
7. Insert a flat blade screwdriver between the bottom of the outer race of the bearing (17) and the bottom lip of the bearing seat (18) and remove the bearing (17).

STEERING COLUMN ASSEMBLY

1. Insert bearing seat (18) into both ends of steering tube (20). Place a block of wood on bearing seat and tap lightly on block until bearing seat (18) is fully seated in steering tube (20) (**Figure 7-4, Page 7-5**).
2. Press the bearing (17) all the way into the bearing seat (18) using a steering column bearing press tool (CCI P/N 1014264) or a metal tube approximately six inches (15.2 cm) long with a maximum outer diameter of 1-3/16 inches (3.3 cm) and a minimum inside diameter of 7/8 inch (2.2 cm). Be sure the bearing is installed in the bearing seat as shown (**Figure 7-4, Page 7-5**) so the wedge (16) will ride against the inner race of the bearing.

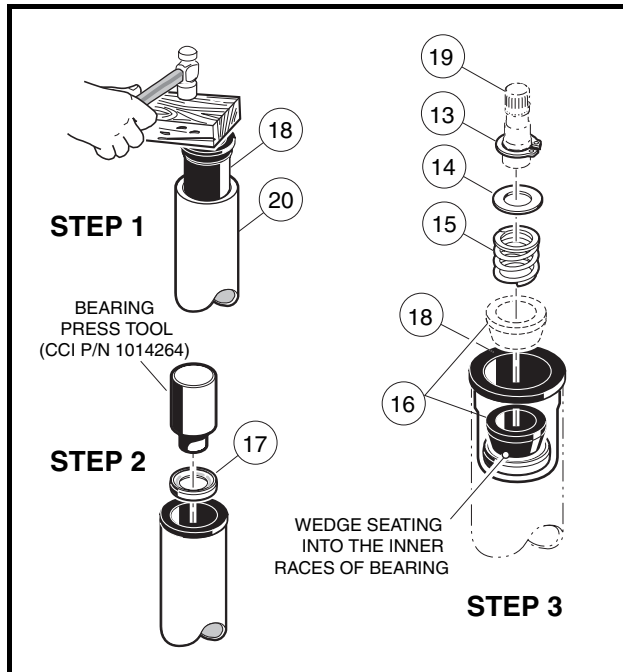

Figure 7-4 Steering Shaft – Bottom End

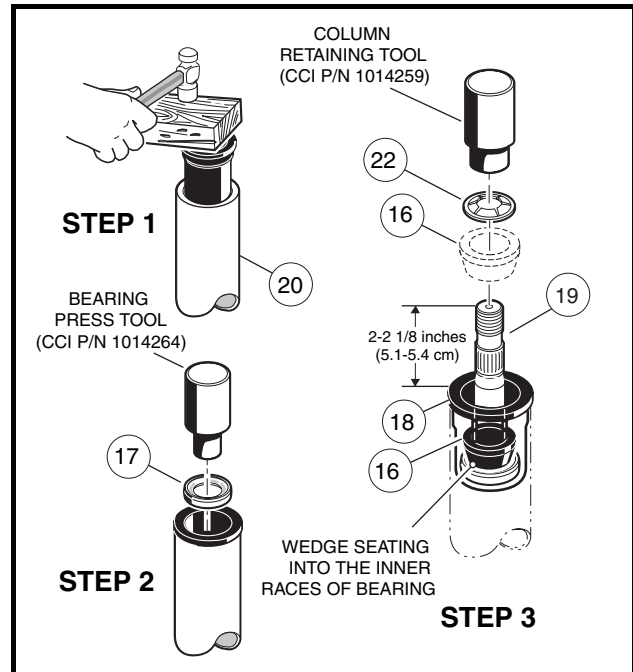

Figure 7-5 Steering Shaft – Top End

3. Install the wedge (16), spring (15), washer (14), and snap ring (13) onto the bottom end of the steering shaft (19) (**Figure 7-4, Page 7-5**).
4. Insert the shaft (19) from the bottom of the steering tube (20) (**Figure 7-3, Page 7-3**).
5. Turn the assembly over and place the shaft (19) on a bench. Install the wedge (16) and retaining ring (22) onto the top of the shaft (**Figure 7-5, Page 7-5**). Be sure the prongs on the retaining ring face up and away from the wedge. Use a steering column retaining ring tool (CCI P/N 1014259) to seat the retaining ring to the proper depth. Support end of tube while pressing. If you do not have the recommended tool, use the same tube as was used in step 2 to press the retaining ring onto the top of the shaft. The retaining ring should be pressed onto the shaft until 2 to 2-1/8 inches (5.1-5.4 cm) of the shaft extends from the top of the bearing seat in the steering tube (**Figure 7-5, Page 7-5**).

STEERING COLUMN INSTALLATION

1. Install boot (12). Reinstall mount (4 and 5) onto the end of the steering column. Tighten bolts (6) to 20 ft-lb (27 N·m) (**Figure 7-3, Page 7-3**).
2. For ease of assembly and to prevent corrosion, apply a light coat of anti-seize or lubricating compound to both splined ends of the steering shaft.
3. Position the steering column assembly in the vehicle while inserting the steering column shaft into the upper universal joint (1). The flat portion of the steering shaft spline (19) must be aligned with the bolt hole in the universal joint (1) before sliding the spline into the universal joint. While holding the steering column in place, attach it to the frame using bolts (8) washers (7) and nuts (9) (**Figure 7-3, Page 7-3**). Thread the nuts onto the bolts but do not tighten them.
4. Reinstall washers (29 and 11) and screw (10). Tighten to 20 ft-lb (27 N·m).
5. Install the bolt (2) and lock washer (3) on the upper universal joint and finger-tighten.
6. Tighten the two nuts (9) and bolts (8) to 17 ft-lb (23 N·m).
7. Tighten the bolt (2) on the upper universal joint to 15 ft-lb (20 N·m).

8. Check the other two bolts on the universal joint (1) to ensure that they are properly tightened to 15 ft-lb (20 N·m) (**Figure 7-3, Page 7-3**).
9. Reinstall dash pocket and related hardware.
10. Reinstall instrument panel in reverse order of disassembly. Make sure the instrument panel is properly seated and fastened into place.
11. Install front body and bumper. **See Section 4 – Body and Trim.**

STEERING ADJUSTMENT

See General Warning on page 1-1.

1. Turn the steering wheel all the way to the right. Note the distance between the passenger-side spindle stop (2) and passenger-side A-plate (3) (**Figure 7-6, Page 7-7**). The internal stop on the rack must reach its limit of travel against rack and pinion housing at exactly the same time the spindle stops against the passenger-side A-plate (with vehicle wheels turned to the right). If simultaneous contact occurs, steering is in correct adjustment; Proceed to step 4. If simultaneous contact does not occur, proceed to step 2.
2. Loosen the nuts (27 and 29) and turn the drag link (28) (**Figure 7-8, Page 7-8**) to adjust the drag link rod. Adjust the link rod with the steering wheel turned all the way to the right, so the passenger-side spindle stop lightly touches the passenger-side A-Plate. The internal stop on the rack must reach its limit of travel at the same time the spindle stops against the passenger-side A-plate (with vehicle wheels turned to the right). **See following CAUTION.**

CAUTION

- **The drag link has both left and right-hand threads. The end of the drag link toward the spindle has left-hand threads, and the end toward the rack has right-hand threads. To prevent damage to threaded parts, care should be taken when servicing the drag link.**
3. When all adjustments have been completed, tighten the nuts (27 and 29) on the drag link assembly with an open end wrench. Tighten nuts to 21 ft-lb (28.4 N·m) (**Figure 7-8, Page 7-8**). **See following CAUTION.**

CAUTION

- **When tightening the nuts (27 and 29), make sure the drag link (28) does not turn (Figure 7-8, Page 7-8).**
4. Straighten wheels and then turn steering wheel from lock to lock. Wheels should turn smoothly and easily. If steering wheel does not turn smoothly and easily, inspect steering assemblies; e.g., ball joints (23) (**Figure 7-8, Page 7-8**) and (6 and 13) (**Figure 7-19, Page 7-17**), spindle bushings (3 and 4) (**Figure 7-20, Page 7-18**), wave washers (20) (**Figure 7-20, Page 7-18**), and rack assembly (17) (**Figure 7-8, Page 7-8**). Also inspect front suspension assemblies; e.g., A-Plates (1) (**Figure 7-19, Page 7-17**) urethane bushings (2) (**Figure 7-19, Page 7-17**) and leaf springs (6) (**Figure 7-20, Page 7-18**). Replace components as necessary.

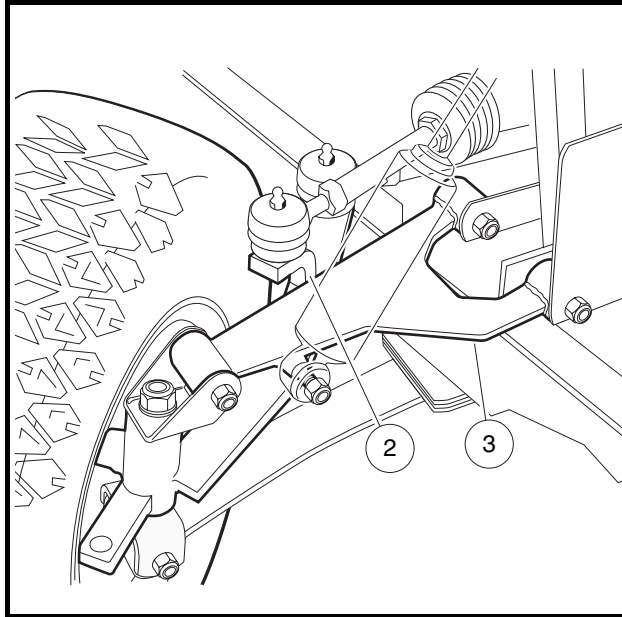

Figure 7-6 Adjust Steering Alignment

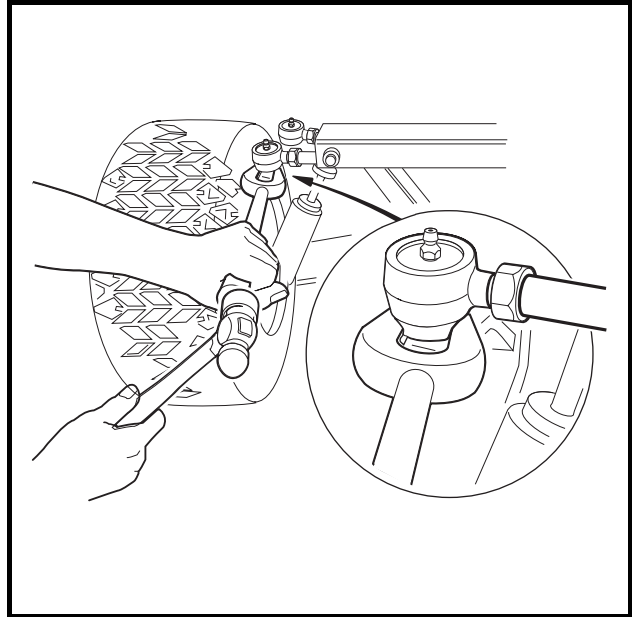

Figure 7-7 Ball Joint Tool

RACK AND PINION

See General Warning on page 1-1.

RACK AND PINION REMOVAL

1. Remove the front body as instructed in Section 4 – Body and Trim.
2. Remove the cotter pin (22) and ball joint retaining nut (25) (**Figure 7-8, Page 7-8**).
3. Using a ball joint removal tool, remove the ball joint (23) (**Figure 7-8, Page 7-8**) from the spindle assembly. See **Figure 7-7, Page 7-7**.
4. Remove the bolts (30), washers (31), and lock nuts (32) from the steering rack assembly mounting bracket (**Figure 7-8, Page 7-8**).
5. Remove the bolt (2) and flat washer (3) on the upper universal joint, then remove the rack assembly and universal joint from the vehicle (**Figure 7-3, Page 7-3**).

RACK AND PINION DISASSEMBLY

CAUTION

- The ball joint (23) (**Figure 7-8, Page 7-8**) has left-hand threads.

1. Remove ball joint (23) and inspect it for excessive wear (**Figure 7-8, Page 7-8**).
2. Remove the drag link (28) (**Figure 7-8, Page 7-8**).
3. Remove both bellows clamps (2) (plastic wire ties).
4. Remove the hex nut (29) and slide off the dust seal bellows (1).
5. Remove the retaining ring (21), then slide off dust seal bellows (20).

6. Remove the rack screw lock nut (15), rack guide screw (16), rack guide pressure spring (14), and the rack guide (13).
7. Remove the universal joint assembly from the pinion (8) by fully removing the bolt and then sliding off the universal joint.
8. If necessary, remove the dust seal (12). **See following NOTE.**

NOTE: If the dust seal (12) is removed, replace with a new one (Figure 7-8, Page 7-8).

9. Using snap ring pliers, remove the internal snap ring (11) (Figure 7-8, Page 7-8).
10. Install the universal joint onto the pinion and place a large open end wrench under the universal joint (Figure 7-9, Page 7-9). Use the wrench as a lever to pull the pinion from the housing.

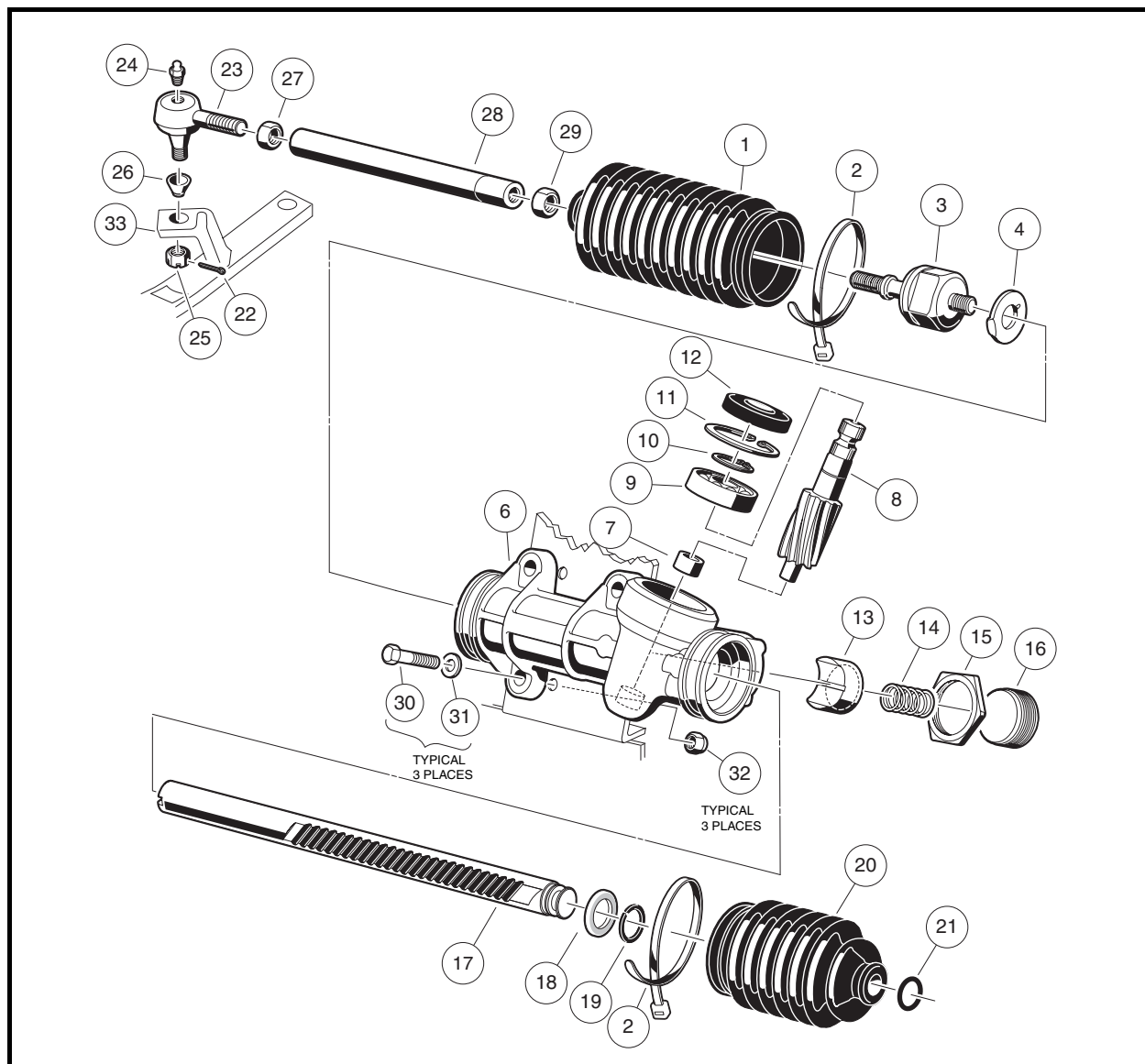

Figure 7-8 Steering Gear

11. If the ball bearing (9) has been damaged, remove the external snap ring (10) (**Figure 7-8, Page 7-8**) and press the bearing off (**Figure 7-10, Page 7-9**).

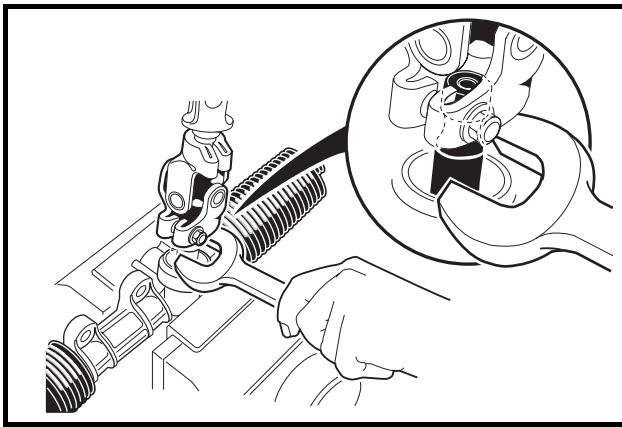

Figure 7-9 Remove Pinion from Housing

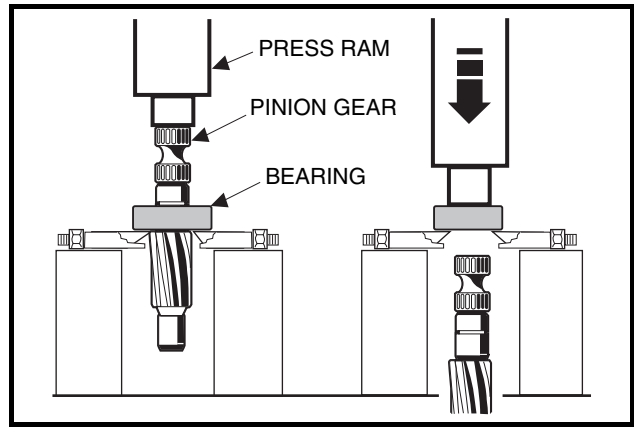

Figure 7-10 Remove Bearing from Pinion

12. Remove retaining ring (19) and stop washer (18), then remove rack (17) from housing (6) (**Figure 7-8, Page 7-8**).
13. If the inner ball joint (3) is excessively worn, remove the ball joint and tab washer (4) from the rack (**Figure 7-11, Page 7-9**).
- 13.1. Secure the rack in a vise using wood blocks between the rack and the jaws of the vise to protect the rack from damage (**Figure 7-11, Page 7-9**).
- 13.2. Loosen and remove the inner ball joint with a wrench.

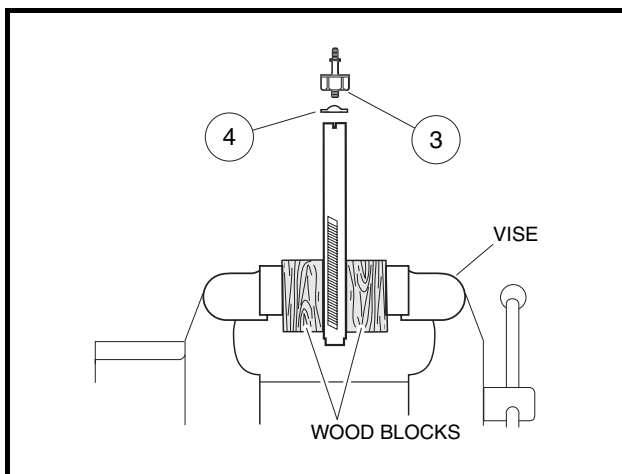

Figure 7-11 Secure Rack in Vise

14. Inspect the bushing inside the steering box assembly (6) for excessive wear. If wear is excessive, replace the steering box assembly (CCI P/N 101878302) (**Figure 7-8, Page 7-8**).

RACK AND PINION ASSEMBLY

1. Install a new tab washer (4) and an inner ball joint (3) (**Figure 7-11, Page 7-9**). Install the ball joint onto the rack by securing the rack in a vise using wood blocks between the rack and the jaws of the vise to protect the rack from damage. Tighten the ball joint to 60 ft-lb (81 N·m).
2. Bend the edges of the tab washer (4) up against the ball joint (3).
3. Apply a liberal amount of EP grease to the teeth of the rack (17), then slide the rack through the housing (6). Install the stop washer (18) and retaining ring (19) to the end of the rack (**Figure 7-8, Page 7-8**). See following **CAUTION**.

CAUTION

- In step 4, do not press against the outer race of the bearing.
4. If the bearing (9) was removed, grease and press on a new bearing, exerting all pressure on the inner race. (**Figure 7-8, Page 7-8**)
 5. Install the external snap ring (10).
 6. If the needle bearing (7) is damaged, the steering box assembly (CCI P/N 101878302) must be replaced.
 7. Install pinion (8) and bearing (9) assembly into the housing (6) (**Figure 7-8, Page 7-8**). Make sure the rack gear teeth will mesh with the gear teeth on the pinion. The rack may need to be rotated slightly while lightly tapping on the pinion-bearing assembly with a rubber mallet. See following **CAUTION**.

CAUTION

- Do not force the pinion-bearing assembly into the housing. The gear teeth or the small bearing could be damaged.
8. Install the internal snap ring (11) (**Figure 7-8, Page 7-8**).
 9. Use a socket to apply pressure evenly, and press in a new dust seal (**Figure 7-12, Page 7-10**).

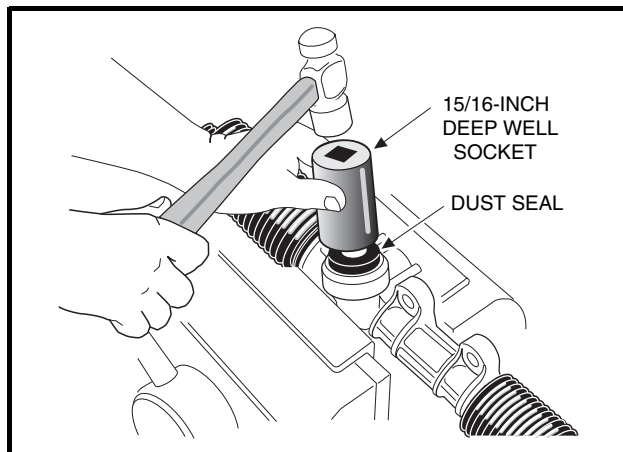

Figure 7-12 Press In Dust Seal

10. Apply a small amount of grease to the rack guide (13) where it comes into contact with the rack (17) (**Figure 7-8, Page 7-8**).
11. Place a few drops of Loctite® 222 on the threads of the screw (16) (**Figure 7-8, Page 7-8**).

12. Install the rack guide (13), pressure spring (14), and screw (16). The screw should be threaded in until a rotational torque of 10 in-lb (1.13 N·m) is achieved (**Figure 7-8, Page 7-8**).
- 12.1. Reposition the rack and pinion in a vise.
- 12.2. Insert a 3/8 inch deep well socket into the steering column end of the universal joint (2) and tighten the bolt (1) to 15 ft-lb (20.3 N·m) (**Figure 7-14, Page 7-11**).
- 12.3. Use a torque wrench connected to the 3/8 inch deep well socket to measure the resistance of the rack and pinion. Rotational resistance should measure 7 to 15 in-lb (.8 to 1.7 N·m).
- 12.4. If measured resistance does not equal 7 to 15 in-lb, loosen the lock nut (15) and tighten the screw (16) until it bottoms out, then back the screw off one quarter turn. Tighten the lock nut to 28 ft-lb (38 N·m) (**Figure 7-13, Page 7-11**). **See following NOTE.**

NOTE: When tightening the lock nut (15), make sure the screw (16) does not change adjustment (**Figure 7-13, Page 7-11**).

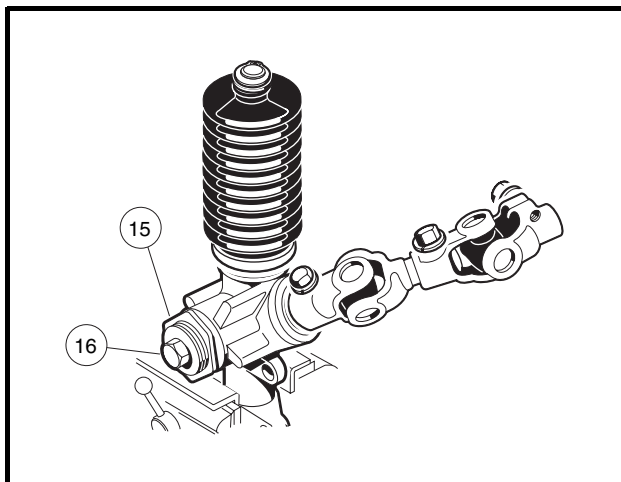

Figure 7-13 Rack and Pinion Adjustment

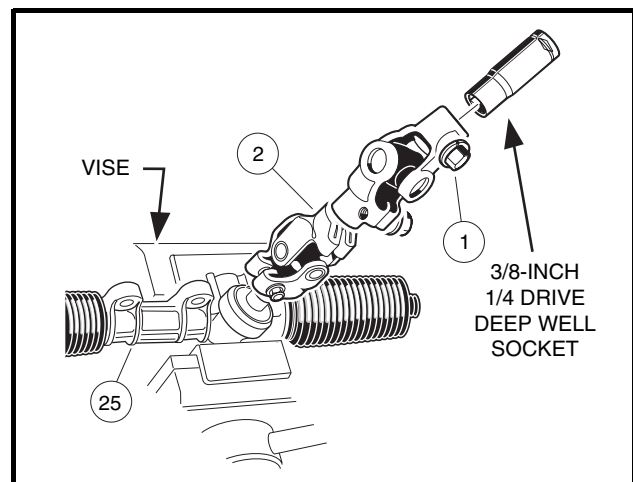

Figure 7-14 Rack and Pinion Resistance

13. Install the dust seal bellows (20) and retaining ring (21) (**Figure 7-8, Page 7-8**).
14. Install the dust seal bellows (1) and hex nut (29).
15. Install the universal joint on the pinion. Tighten the bolt to 15 ft-lb (20 N·m).
16. Install new bellows clamps (wire ties) (2).
17. Install the drag link (28) by fully threading the grooved end onto the inner ball joint (3). **See following CAUTION.**

CAUTION

- The ball joint (23) (**Figure 7-8, Page 7-8**) has left-hand threads.
- The tie rod and drag link have right-hand threads on one end and left-hand threads on the other end. Right-hand threads are identified by a groove in the tie rod or drag link.

18. Install the ball joint (23). **See preceding CAUTION.**

RACK AND PINION INSTALLATION

1. Position the steering gear box assembly on the shock and gear support and install the bolts (30), washers (31), and nuts (32). Do not tighten the mounting bolts (**Figure 7-8, Page 7-8**).
2. For ease of assembly and to prevent corrosion, apply a light coat of anti-seize and lubricating compound to the splined end of the steering column shaft.
3. Align the flat portion of the steering shaft spline with the bolt hole in the universal joint and then slide the shaft into the upper universal joint. Install the bolt and lock washer on the upper universal joint and tighten to 15 ft-lb (20 N·m).
4. Tighten the steering rack mounting bolts (30) to 22 ft-lb (29.8 N·m) (**Figure 7-8, Page 7-8**).
5. Adjust the steering. **See Steering Adjustment on page 7-6.**

TIE ROD AND DRAG LINK

See General Warning on page 1-1.

TIE ROD AND DRAG LINK REMOVAL

1. Using locking pliers to hold tie rod and drag link, loosen jam nuts (7 and 12) on tie rod ball joints (**Figure 7-19, Page 7-17**), and loosen jam nuts (27 and 29) on the drag link (**Figure 7-8, Page 7-8**).
2. Remove the cotter pin (22) and ball joint retaining nut (25) (**Figure 7-8, Page 7-8**).
3. Remove the cotter pins (22) and ball joint retaining nuts (20) (**Figure 7-20, Page 7-18**).
4. Use a ball joint removal tool to remove ball joints (13 and 6) (**Figure 7-19, Page 7-17**) and (23) (**Figure 7-8, Page 7-8**) from the spindles.
5. Remove the ball joints from the tie rod (11) (**Figure 7-19, Page 7-17**).
6. Remove drag link (28) from inner ball joint assembly (3) and drag link ball joint (23) (**Figure 7-8, Page 7-8**).

TIE ROD AND DRAG LINK INSTALLATION

1. Thread ball joints (6 and 13) into tie rod (11) to a depth of 1/2 inch (12.5 mm) (**Figure 7-19, Page 7-17**). See following **WARNING** and **CAUTION**.

⚠ WARNING

- The ball joints must be threaded into the rod at least 5/16 of an inch (8 mm). Failure to thread ball joints in deep enough may cause a ball joint to separate from the rod during adjustment or while being operated, possibly resulting in loss of vehicle control and severe personal injury.

CAUTION

- The tie rod and drag link have right-hand threads on one end and left-hand threads on the other end. Right-hand threads are identified by a groove in the tie rod or drag link.
2. Install ball joint ends (6 and 13) into the left and right-hand spindle arms (23), then install the retaining nuts (20) and cotter pins (22) (**Figure 7-19, Page 7-17**).

3. Thread the drag link rod (28) all the way onto the threaded stud of the inner ball joint assembly (3) (right-hand threads) (**Figure 7-8, Page 7-8**).
4. Thread the ball joint (23) into the drag link rod (28) (left-hand threads) to full thread depth (**Figure 7-8, Page 7-8**).
5. Install the ball joint (23) on the spindle arm riser (33), then install the retaining nut (25) (**Figure 7-8, Page 7-8**). Tighten nut to 21 ft-lb (28.4 N·m), then install a new cotter pin (22).
6. Adjust wheel toe-in (**see page 7-14**) and steering (**see page 7-6**).

FRONT SUSPENSION

See General Warning on page 1-1.

LUBRICATION

Five grease fittings are provided (one in each spindle housing, one in the ball joint on each end of the tie rod, and one in the ball joint of the steering drag link). Lubricate these fittings at the recommended interval with the proper lubricant. **See Periodic Lubrication Schedules, Section 10, Page 10-4. See following CAUTION.**

CAUTION

- To ensure proper lubrication of the front suspension and steering linkages, raise front of vehicle to lubricate. See General Warning, Section 1, Page 1-1.

WHEEL ALIGNMENT

Wheel alignment is limited to equalizing the camber angle of each front wheel and adjusting toe-in of the front wheels. There is also a drag link adjustment to equalize the turning radius in both directions. **See Steering Adjustment on page 7-6. See following NOTE.**

NOTE: Prior to making any front suspension adjustments, inspect components for wear or damage and repair or replace as necessary.

Camber Adjustment

1. Check each front wheel with a framing square. From the floor (or ground), they should be perpendicular with a framing square (**Figure 7-15, Page 7-14**).
2. Loosen, but do not remove, the four bolts (30) that secure the leaf spring (6) to the bottom spring plate (29) (**Figure 7-20, Page 7-18**). See also **Figure 7-16, Page 7-14**.
3. Loosen, but do not remove, the hex nut (8) on the adjustment eccentric (7) (**Figure 7-16, Page 7-14**) in the center of the spring. See also **Figure 7-20, Page 7-18**.
4. Use a 7mm deep-well socket to rotate the eccentric (**Figure 7-16, Page 7-14**).
5. After adjusting camber, tighten the four spring retaining bolts (30) (**Figure 7-20, Page 7-18**) to 23 ft-lb (31 N·m). Then roll the vehicle forward one full tire revolution and recheck the camber. See also **Figure 7-15, Page 7-14**.
6. Tighten the hex nut (8) on the adjustment eccentric (7) to 10 ft-lb (13.5 N·m) (**Figure 7-20, Page 7-18**) See also **Figure 7-16, Page 7-14**.

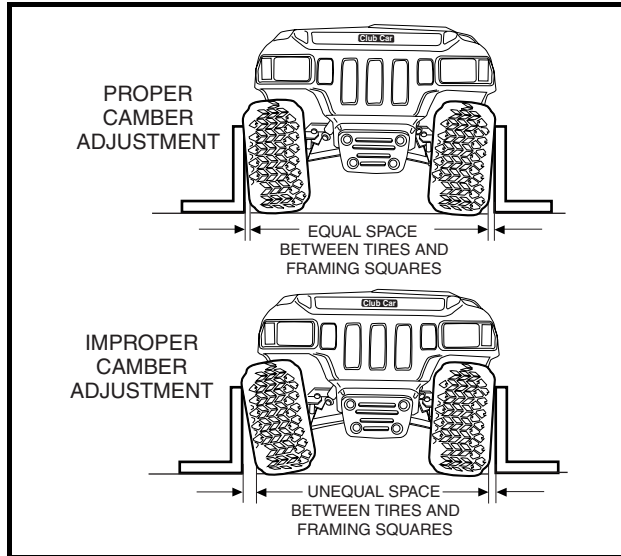

Figure 7-15 Check Camber

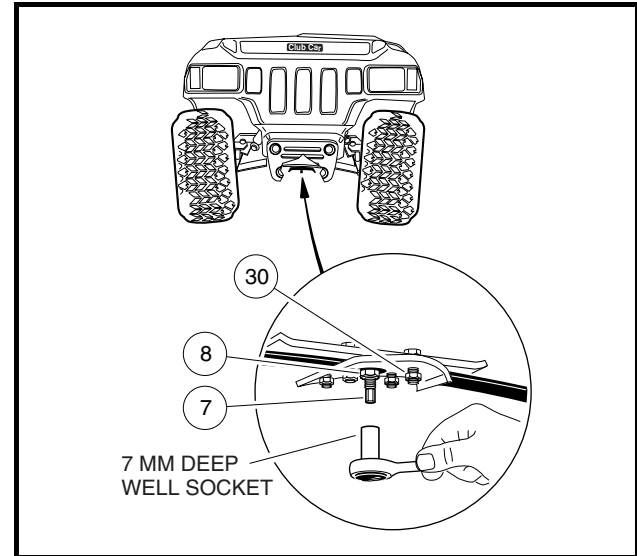

Figure 7-16 Adjust Camber

Toe-in Adjustment

1. On a level surface, roll the vehicle forward, then stop. Make sure the front wheels are pointed straight ahead. Do not turn the steering wheel again during this procedure.
2. On each front tire, mark (as closely as possible) the center of the tread face that is oriented toward the rear of the vehicle. The marks should be even with the bottom surfaces of the vehicle frame I-beams.
3. Measure the distance between the marks on the rear-facing surfaces of the tires, and then roll the vehicle **forward** one and one-half wheel revolutions until the marks appear on the forward facing surfaces of the tires at about the same height from the floor (**Figure 7-17, Page 7-14**).

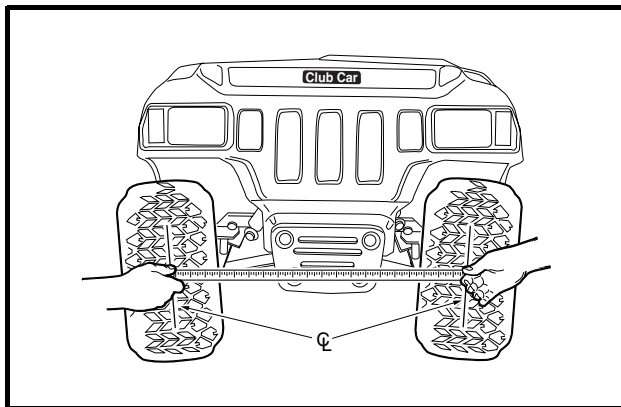

Figure 7-17 Check Toe-In

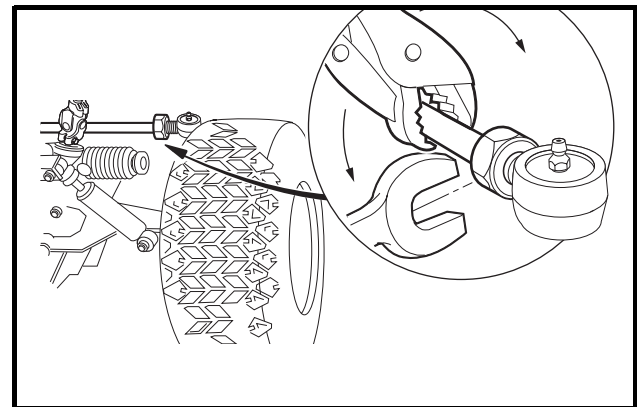

Figure 7-18 Adjust Toe-In

4. Measure the distance between the marks on the forward-facing surfaces of the tires (**Figure 7-17, Page 7-14**). **See following NOTE.**

NOTE: The front measurement must be less than the rear measurement.

5. Subtract the measurement on the front of the tires from the measurement on the rear of the tires. The difference is the toe-in. Proper toe-in is 1/8 to 3/8 of an inch (3.2 to 9.5 mm).

6. If adjustment is necessary, loosen the jam nut on each tie rod ball joint and rotate the tie rod to increase or decrease toe-in (**Figure 7-18, Page 7-14**). **See following CAUTION.**

CAUTION

- **The tie rod has right-hand threads on one end and left-hand threads on the other end. Right-hand threads are identified by a groove in the tie rod.**

7. Tighten nuts (loosened in step 6) to 21 ft-lb (28 N·m) and recheck toe-in.
8. After toe-in adjustment is made and with wheels in the straight ahead position, the steering wheel should be at the center of its travel. There should be equal travel to the left and right. **See following NOTE.**

NOTE: *If the minimum turning radius is not the same for both left and right turns, adjust the steering (see **Steering Adjustment on page 7-6**).*

If the vehicle is equipped with the permanent towing or deluxe onboard towing option, adjust by loosening the ball joint hex nut on the tow assembly and rotating the steering arm to achieve 16 -1/2 inches (42 cm) from centerline of right front tire to the closest edge of the hole in towing lug.

FRONT SUSPENSION COMPONENTS

See General Warning on page 1-1.

TAPERED LEAF SPRING REMOVAL

1. Loosen lug nuts on both front wheels and raise front of vehicle with a chain hoist or floor jack. Place jack stands under the front cross tube of the vehicle frame and lower the vehicle onto the jack stands. **See General Warning, Section 1, Page 1-1.**
2. Remove both front wheels.
3. Remove the nuts (14) and bolts (25) from the bottom of each kingpin (26) (**Figure 7-20, Page 7-18**).
4. Remove the four bolts (30), four nuts (36), four lock washers (37), and bottom spring plate (7).
5. Remove tapered leaf spring (6) and spacer plates (1).
6. Check the condition of the urethane bushings (27) and steel bushings (28). Replace any that are worn or damaged.

TAPERED LEAF SPRING INSTALLATION

1. Install urethane bushings (27) and steel bushings (28) into leaf spring eyes (**Figure 7-20, Page 7-18**).
2. Install spacer plates (1), tapered leaf spring (6), bottom spring plate (7), four bolts (30), four lock washers (37), and four nuts (36). Using a crisscross pattern sequence, tighten bolts to 23 ft-lb (31 N·m).
3. Install spring in kingpins (26) with bolts (25) and nuts (14). Tighten to 23 ft-lb (31 N·m).
4. Install the wheels and finger-tighten the lug nuts.
5. Lower the vehicle and finish tightening lug nuts (using a crisscross pattern) to 55 ft-lb (74.6 N·m).
6. Adjust camber and toe-in as instructed on page 7-13.

KINGPIN AND STEERING SPINDLE REMOVAL

1. Remove the front hub. **See Front Wheel Bearings and Hubs on page 7-19.**
2. Remove cotter pins (22) and nuts (20), then remove ball joints from the spindles (**Figure 7-19, Page 7-17**). Remove drag link ball joint. **See also Tie Rod and Drag Link Removal on page 7-12.**
3. Remove the nut (17) and lock washer (if present) from the top of the kingpin (26) (**Figure 7-20, Page 7-18**).
4. Raise the upper clevis (16) from the kingpin (**Figure 7-20, Page 7-18**).
5. Remove the thrust washer (19).
6. Slide the spindle (38) off the kingpin (26).
7. Remove the wave washer (20) and inspect it. If the washer is broken or has a wave bottom to wave crest height dimension of less than 0.040 inch (0.10 cm), it must be replaced.
8. Remove bolt (25) and nut (14) from bottom of kingpin (26) and remove kingpin.
9. Inspect the kingpin and spindle. If either is worn or damaged, it must be replaced.
10. Inspect the bushings (3 and 4). If the bushings are worn or damaged, remove them and press in new ones. **See following NOTE.**

NOTE: If the bushings are replaced, ream new bushings to 0.750-0.752 (3/4 inch) (19.05-19.10 mm) in diameter. The reamer should be long enough to ream both bushings from one direction.

KINGPIN AND STEERING SPINDLE INSTALLATION

1. Inspect all parts and replace them as necessary.
2. Install the kingpin (26) over the leaf spring eye. Insert the bolt (25) and install the nut (14) (**Figure 7-20, Page 7-18**). Tighten the bolt to 23 ft-lb (31 N·m).
3. Install the wave washer (20) on the kingpin.
4. Slide the spindle (38) with bushings (3 and 4) over the kingpin (26).
5. Install the thrust washer (19), upper plate clevis (16), and nut (17). If lock washer was present, do not reinstall. Tighten the nut to 40 ft-lb (54.2 N·m) (**Figure 7-20, Page 7-18**).
6. Attach the ball joints (6 and 13) to the spindle arm (23), install and tighten the nut (20), and install the cotter pin (22) (**Figure 7-19, Page 7-17**).
7. Install the drag link ball joint. **See Tie Rod and Drag Link Installation on page 7-12.**
8. Install front hub and wheel. **See Front Hub Installation on page 7-20.**

DELTA A-PLATE REMOVAL

1. Loosen lug nuts on both front wheels and raise front of the vehicle with a chain hoist or floor jack. Place jack stands under the front cross tube of the vehicle frame and lower the vehicle onto the jack stands.
2. Remove wheel.
3. Remove bolts (10 and 24), A-Plate straps (14), and nuts (5) (**Figure 7-19, Page 7-17**).
4. Remove the lower shock absorber mounting nut (9), then slide the shock absorber free of the Delta A-Plate.
5. Remove the Delta A-Plate (1).
6. Inspect the bushings (2) and sleeves (3 and 4) in the Delta A-Plate and replace them if necessary.

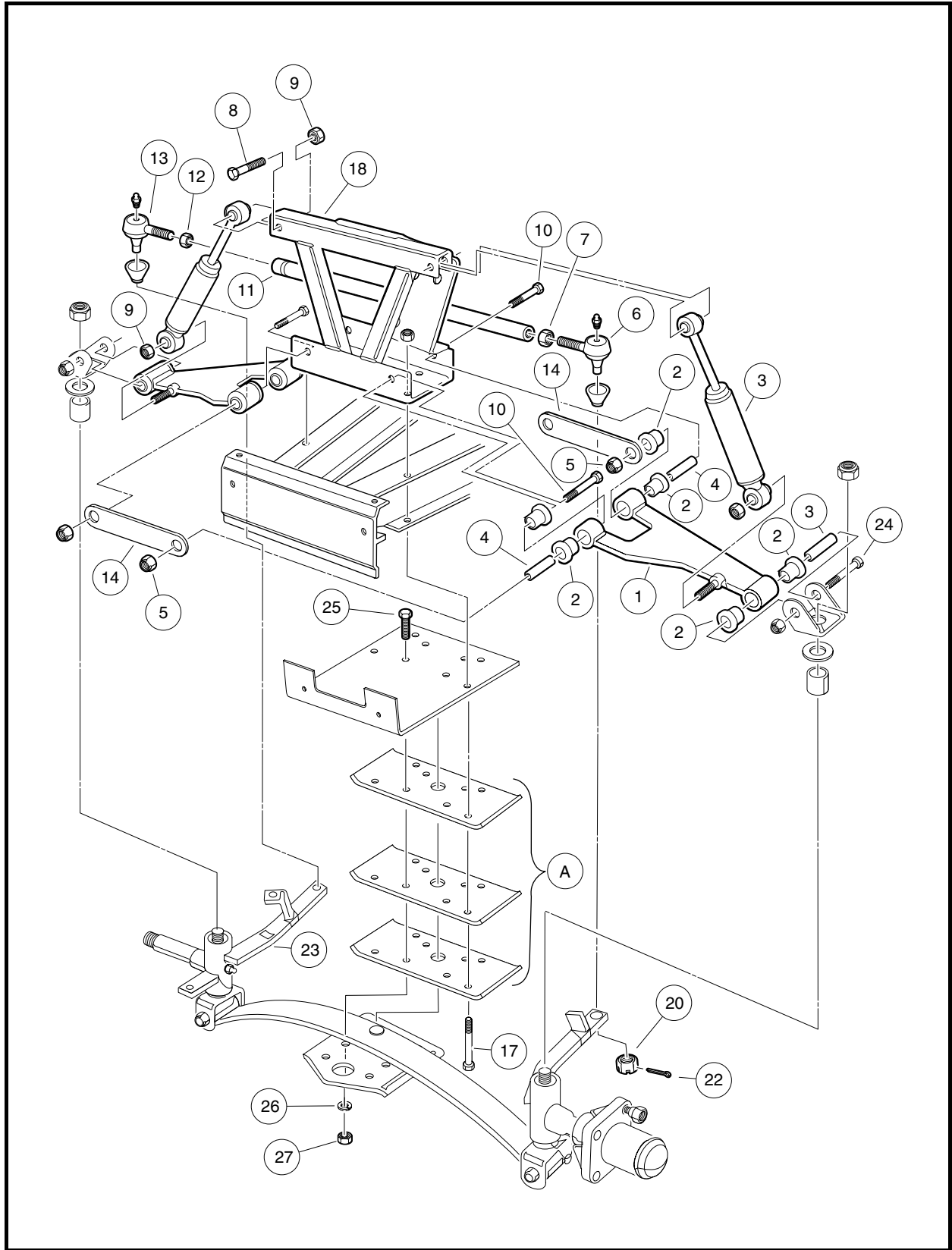

Figure 7-19 Upper Front Suspension Assembly

A. Number of spacer plates used on vehicle: Three on the 850; Five on the 800/810

DELTA A-PLATE INSTALLATION

1. Install the A-Plate in reverse order of removal. Tighten the A-Plate suspension bolts (10 and 24) to 20 ft-lb (27 N·m) (**Figure 7-19, Page 7-17**).
2. Tighten shock absorber mounting nut (9) to 20 ft-lb (27.1 N·m).
3. Install the wheels and adjust the wheel alignment as instructed on page 7-13.

SHOCK ABSORBER REMOVAL

1. Inspect the shock absorbers for fluid leakage at the point where the shaft enters the shock absorber body. Leaking shock absorbers should be replaced.
2. Remove the nut (9) attaching the shock absorber to the A-Plate (**Figure 7-19, Page 7-17**).
3. Remove the nut (9) and bolt (8) attaching the shock absorber to the shock and gear support.
4. Remove the shock absorber.

SHOCK ABSORBER INSTALLATION

NOTE: When installing shock absorbers, make sure front shocks have identical part numbers and rear shocks have identical part numbers.

1. Install the shock absorber by reversing the removal procedure.
2. Tighten the nuts to 20 ft-lb (27 N·m).

FRONT WHEEL BEARINGS AND HUBS

See **General Warning** on page 1-1.

NOTE: The hubs used on this vehicle contain sealed bearings that cannot be serviced or replaced. If the bearings are worn or damaged, the entire hub must be replaced.

FRONT WHEEL FREE PLAY INSPECTION

1. Raise the front of the vehicle.
2. Use your hands to attempt to rock the wheel and hub assembly back and forth on the spindle. If there is any observable movement of the wheel and hub on the spindle, the hub bearing is worn and the hub assembly must be replaced. **See Front Hub Removal on page 7-19.**

FRONT HUB REMOVAL

1. Remove the front wheels. **See Wheel Removal, Section 8, Page 8-1.**
2. Remove dust cap (1) and lock nut (2) (**Figure 7-21, Page 7-20**).
3. Slide the hub assembly (3) off of the spindle shaft (4).
4. Lightly sand spindle shaft to clean away any light rust.
5. Inspect the surface of the spindle shaft for surface damage. It should be clean and smooth. If severe pitting from rust or corrosion has occurred, replace the spindle assembly. **See Kingpin and Steering Spindle Removal on page 7-16.**

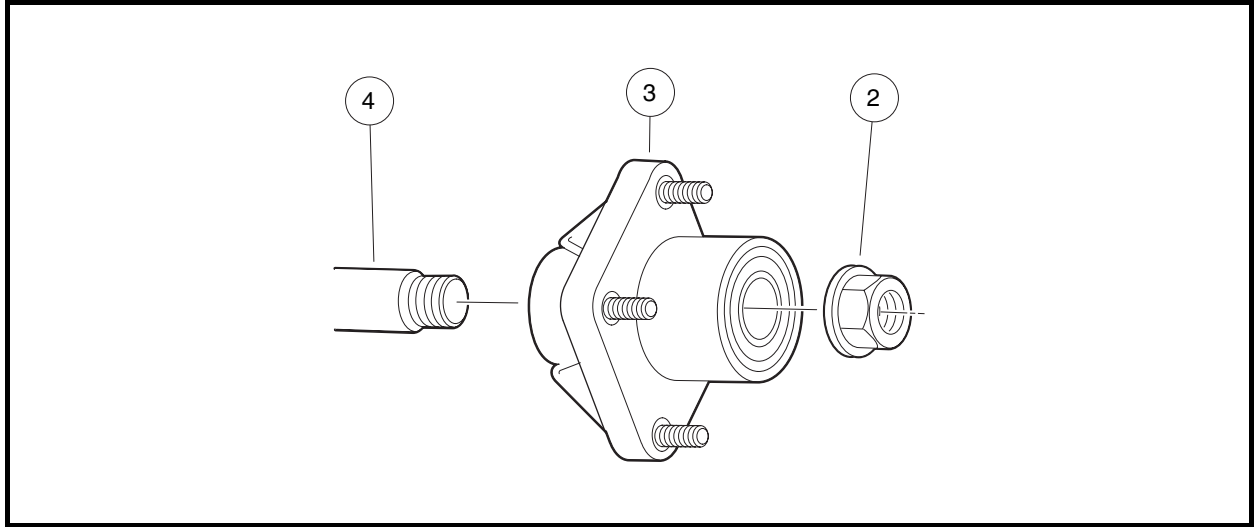

Figure 7-21 Front Wheel Hub

FRONT HUB INSTALLATION

1. Clean and apply a light coat of anti-seize lubricant to the spindle shaft.
2. Slide the hub assembly (3) onto the spindle shaft (**Figure 7-21, Page 7-20**).
3. Install a new flanged lock nut and tighten to 50 ft-lb (68 N·m).
4. Rotate the hub. The hub should rotate smoothly without binding, side play, or any indication of rough spots during rotation.
5. Repeat the procedure for the opposite wheel.
6. Install wheels and finger-tighten lug nuts.
7. Lower the vehicle and finish tightening lug nuts, using a crisscross pattern, to the following amounts:
 - 7.1. For vehicles with steel wheels, tighten the lug nuts to 55 ft-lb (74.6 N·m).
 - 7.2. For XRT 850 vehicles with alloy mag wheels, tighten the lug nuts to 65 ft-lb (88 N·m).

SECTION 8 – WHEELS AND TIRES

DANGER

- See General Warning on page 1-1.

WARNING

- See General Warning on page 1-1.

GENERAL INFORMATION

Maximum tire life and good vehicle handling qualities are directly related to proper wheel and tire care.

- Keep tires properly inflated. **See Section 2 – Vehicle Specifications.**
- Keep lug nuts properly tightened.
- Keep the front end aligned and adjusted.

WHEELS

See General Warning on page 1-1.

WHEEL REMOVAL

1. Slightly loosen the lug nuts on the wheel to be removed.
2. Raise the end of the vehicle from which the wheel is to be removed. Make sure that the wheels are off the ground. **See General Warning on page 1-1.**
3. Remove the lug nuts and remove the wheel.

WHEEL INSTALLATION

1. Install wheel(s), and use a crisscross pattern to tighten the lug nuts until they are snug.
2. Lower the vehicle and finish tightening lug nuts, using a crisscross pattern, to the following amounts:
 - 2.1. For vehicles with steel wheels, tighten the lug nuts to 55 ft-lb (74.6 N·m).
 - 2.2. For XRT 850 vehicles with alloy mag wheels, tighten the lug nuts to 65 ft-lb (88 N·m).

TIRES

See General Warning on page 1-1.

TIRE REMOVAL

NOTE: Tire must be removed or installed from the valve stem side of the rim.

1. Remove the tire and wheel assembly from the vehicle as instructed above.
2. Remove the valve cap and valve core and allow air to escape from the tire.
3. If possible, use a tire machine to remove the tire from the rim.
 - 3.1. If a tire machine is not available, loosen both tire beads by applying pressure to the tire side walls and pushing the tire bead away from the rim flange and into the rim well (**Figure 8-1, Page 8-2, Detail A**).
 - 3.2. With the valve stem side of the wheel up, use a tire tool to carefully start the upper bead over the edge of the wheel rim (**Figure 8-1, Page 8-2, Detail B**). **See following CAUTION.**

CAUTION

- **To avoid damage to the tire, do not use excessive force when starting the bead over the edge of the rim.**
- 3.3. When top bead is free of the rim, pull the bead from the bottom side of the rim up into the upper part of the rim well. Insert the tire tool under the lower bead as shown (**Figure 8-1, Page 8-2, Detail C**) and carefully pry the lower bead over the rim flange.
 - 3.4. Once the lower bead is started over the rim flange, the tire can be removed from the rim by hand.

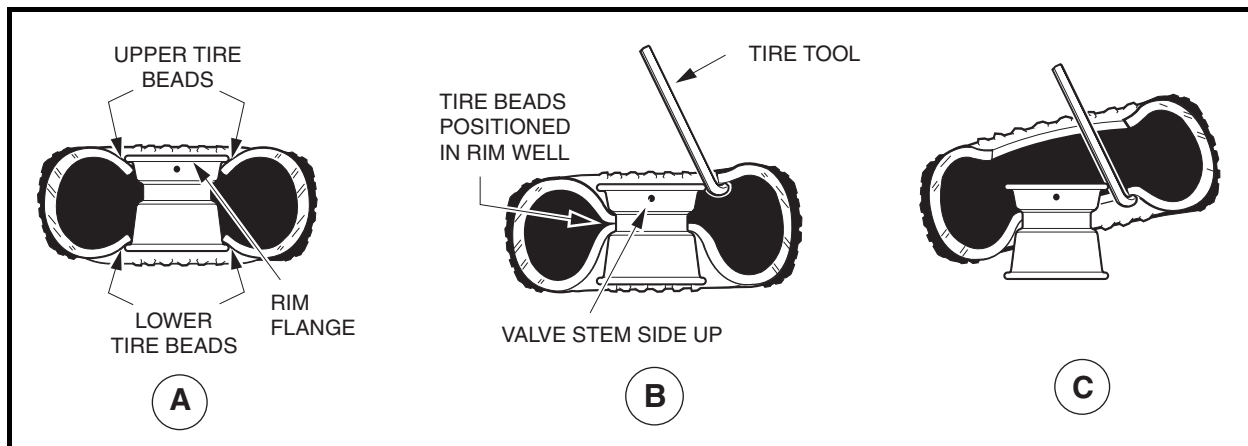

Figure 8-1 Tire Removal

TIRE REPAIR

1. Determine the location and cause of the air leak:
 - 1.1. Remove the wheel. **See Wheel Removal on page 8-1.** Inflate the tire to no more than 20 psi (1.38 Bars).
 - 1.2. Immerse the tire in water and then mark the point where bubbles are formed by escaping air.
 - 1.3. Determine the cause of the air leak. **See following NOTE.**

NOTE: *An air leak could be due to a punctured casing, faulty valve core, improperly seated valve stem, or improperly seated tire bead.*

Small holes in the casing can be plugged using a standard automotive tubeless tire repair kit available at auto supply stores.

2. When the cause of the air leak has been determined, remove tire from the rim and repair as required. **See Tire Removal on page 8-1.**

TIRE INSTALLATION

⚠ WARNING

- While mounting or inflating tire, keep hands, fingers, etc. from exposed areas between the tire bead and rim.

1. Clean both tire beads to remove dirt or other foreign matter.
2. Where the tire beads seat, clean the wheel rim with a wire brush. Wipe away any debris with a clean cloth. **See following NOTE.**

NOTE: Because tubeless tires require a perfect seal in order to seat, keeping the tire and rim clean is very important.

3. Apply a liberal amount of tire-mounting lubricant (soap and water solution) to both tire beads and rim flanges.
4. Install the tire on the rim from the valve stem side. If there is no tire machine available, use a rubber mallet and tire iron.
5. Remove the valve core, and position tire so that both beads are on the rim flange narrow bead seats.
6. Place tire and wheel assembly against wall in upright position and push it against wall while inflating tire to 30-35 psi (2.07-2.42 Bars). The three-point contact (wall, floor, and hand) will help ensure that beads snap into place and form a proper seal as tire is inflated (**Figure 8-2, Page 8-3**). **See following WARNING.**

⚠ WARNING

- Do not use a compressed air source with pressure over 100 psi (6.90 Bars). Due to low pressure requirements of a small tire, over-inflation could be reached almost instantly with a high pressure air supply. Over-inflation could cause tire to explode, possibly resulting in severe personal injury.

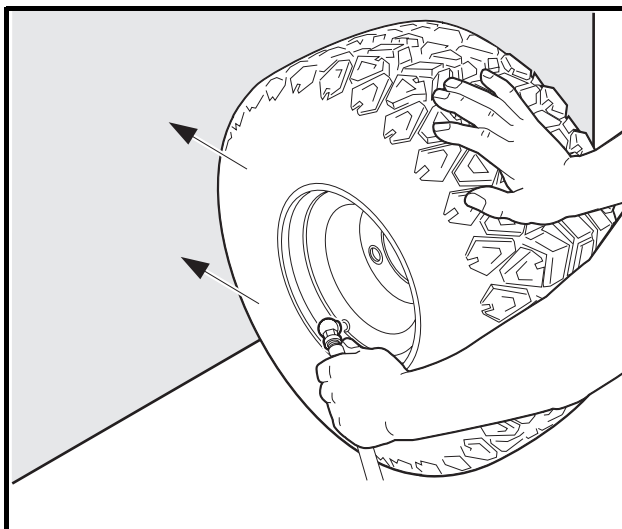

Figure 8-2 Inflate Tire

7. Quickly remove the air nozzle and install the valve core.
8. Adjust air pressure in tire to recommended pressure. **See Section 2 – Vehicle Specifications.**
9. Immerse the wheel and tire assembly in water to make sure there are no leaks.

SECTION 9 – REAR SUSPENSION

⚠ DANGER

- See General Warning on page 1-1.

⚠ WARNING

- See General Warning on page 1-1.

GENERAL INFORMATION

The rear suspension of this vehicle is completely independent. It consists of two leaf springs controlled by two shock absorbers mounted between the springs and the vehicle frame.

SHOCK ABSORBERS

See General Warning on page 1-1.

SHOCK ABSORBER REMOVAL AND INSPECTION

1. Check shock absorbers (7) for damage or fluid leakage at the point where the shaft enters the shock absorber body. Replace damaged or leaking shock absorbers (**Figure 9-3, Page 9-3 and Figure 9-4, Page 9-5**).
2. To remove a shock absorber, remove the nut (5), cup washers (9) and rubber bushings (10) from the stem at the top of the shock absorber.
3. Remove the nut (5), cup washers (9), and rubber bushings (10) from lower mounting stem.
4. Compress the shock absorber to remove it.

SHOCK ABSORBER INSTALLATION

1. To install, reverse the removal procedure.
2. On the upper and lower shock absorber mounting stems, tighten the nuts until the rubber bushing expands to the size of the cup washer.

LEAF SPRINGS

See General Warning on page 1-1.

LEAF SPRING REMOVAL – 800 AND 810

1. Loosen, but do not remove, lug nuts on tire and wheel assembly on the side from which the spring is to be removed. Place chocks at the front wheels and lift the rear of the vehicle with a chain hoist or floor jack. Position jack stands under the frame crossmember between the spring mount and the side stringer, just forward of each rear wheel. Lower the vehicle to let the jack stands support the vehicle (**Figure 9-1, Page 9-2**). See following **WARNING**.

⚠ WARNING

- Lift only one end of the vehicle at a time. Use a suitable lifting device (chain hoist or hydraulic floor jack) with 1000 lb. (454 kg) minimum lifting capacity. Do not use lifting device to hold vehicle in raised position. Use approved jack stands of proper weight capacity to support the vehicle and chock the wheels that remain on the floor. When not performing a test or service procedure that requires movement of the wheels, lock the brakes.

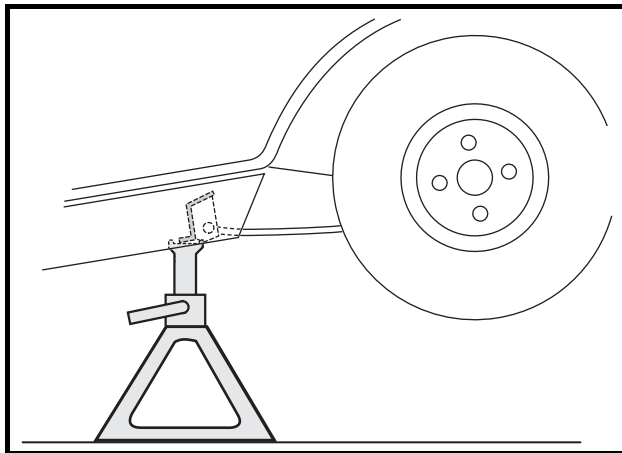

Figure 9-1 Support Vehicle on Jack Stands

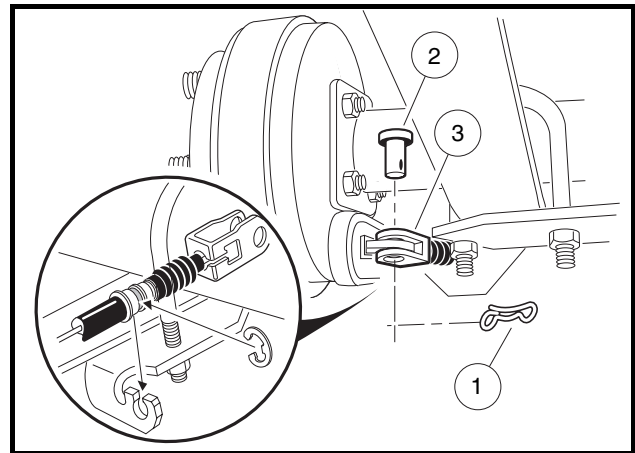

Figure 9-2 Disconnect Brake Cable

2. Place a floor jack under the transaxle differential casing to support (but not lift) the drivetrain. Raise it just enough to relieve tension on the shock absorbers without compressing them.
3. Remove the tire and wheel assembly on the side from which the spring is to be removed.
4. Remove the bow-tie pin (1) and the clevis pin (2) at the brake lever and brake cable connection and pull the clevis (3) away from the lever (**Figure 9-2, Page 9-2**). Detach the brake cable from the shock mount bracket (16) (**Figure 9-3, Page 9-3 and Figure 9-4, Page 9-5**).
5. Remove the nut (5), cup washers (9), and rubber bushings (10) from the lower mounting stem of the shock absorber.
6. Remove the nuts (14) and the U-bolt (11) securing the spring to the jounce bumper bracket (20) and spacer (17) to the transaxle. Remove the shock mount bracket (16), angle bracket (13) and the U-bolt.

7. Remove the nut (2) and bolt (15) attaching the rear spring to the lower end of the shackle brackets (1).
8. Remove the nut (2) and bolt (15) attaching the front of the spring to the vehicle frame and remove the spring.
9. Inspect the bushings (4) and spacers (3) in the spring eyes and replace them if they are worn or damaged.

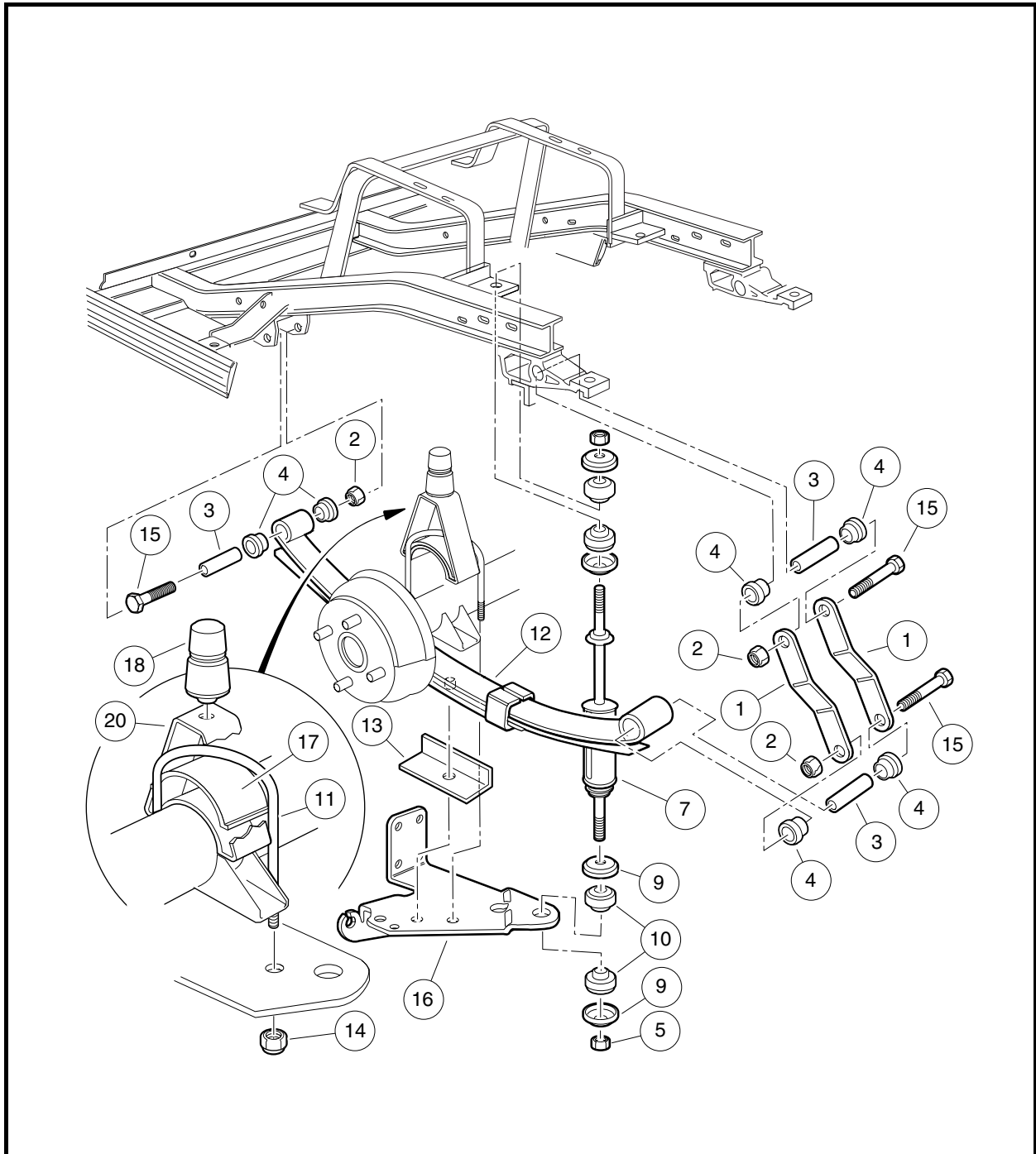

Figure 9-3 Rear Suspension Assembly and Mounting – 800 and 810

LEAF SPRING REMOVAL – 850

1. Loosen, but do not remove, lug nuts on tire and wheel assembly on the side from which the spring is to be removed. Place chocks at the front wheels and lift the rear of the vehicle with a chain hoist or floor jack. Position jack stands under the frame crossmember between the spring mount and the side stringer, just forward of each rear wheel. Lower the vehicle to let the jack stands support the vehicle (**Figure 9-1, Page 9-2**). See following **WARNING**.

⚠ WARNING

- **Lift only one end of the vehicle at a time. Use a suitable lifting device (chain hoist or hydraulic floor jack) with 1000 lb. (454 kg) minimum lifting capacity. Do not use lifting device to hold vehicle in raised position. Use approved jack stands of proper weight capacity to support the vehicle and chock the wheels that remain on the floor. When not performing a test or service procedure that requires movement of the wheels, lock the brakes.**
2. Place a floor jack under the transaxle differential casing to support (but not lift) the drivetrain. Raise it just enough to relieve tension on the shock absorbers without compressing them.
 3. Remove the tire and wheel assembly on the side from which the spring is to be removed.
 4. Remove the bow-tie pin (1) and the clevis pin (2) at the brake lever and brake cable connection and pull the clevis (3) away from the lever (**Figure 9-2, Page 9-2**). Detach the brake cable from the shock mount bracket (16) (**Figure 9-4, Page 9-5**).
 5. Remove the nut (5), cup washers (9), and rubber bushings (10) from the lower mounting stem of the shock absorber.
 6. Remove the nuts (17), bolts (18) and bushing support (19) attaching the rear stabilizer bar (21) to the shock mount bracket (**Figure 9-5, Page 9-6**).
 7. Remove the nuts (14) and the U-bolt (11) securing the spring to the transaxle. Remove the shock mount bracket (16) and the U-bolt.
 8. Remove the nut (2) and bolt (15) attaching the rear spring to the lower end of the shackle brackets (1).
 9. Remove the nut (2) and bolt (15) attaching the front of the spring to the vehicle frame and remove the spring.
 10. Inspect the bushings (4) and spacers (3) in the spring eyes and replace them if they are worn or damaged.

LEAF SPRING INSTALLATION – ALL VEHICLES

1. To install the springs, reverse the removal procedure. See following **CAUTION**.

CAUTION

- **When positioning the spring on the transaxle, be sure to insert the locating bolt on the spring in the locating hole in the transaxle saddle.**
2. Tighten the nuts on the U-bolts to 25 ft-lb (34 N·m).
 3. Tighten nylon lock nuts (2) on spring mounting bolts (15) to 15 ft-lb (20.3 N·m) (**Figure 9-3, Page 9-3**).
 4. Tighten the nuts (5) until the rubber bushing (10) expands to the size of the cup washer (9).
 5. **850 Models:** Tighten the stabilizer bar hardware. See **Stabilizer Bar Installation on page 9-7**.

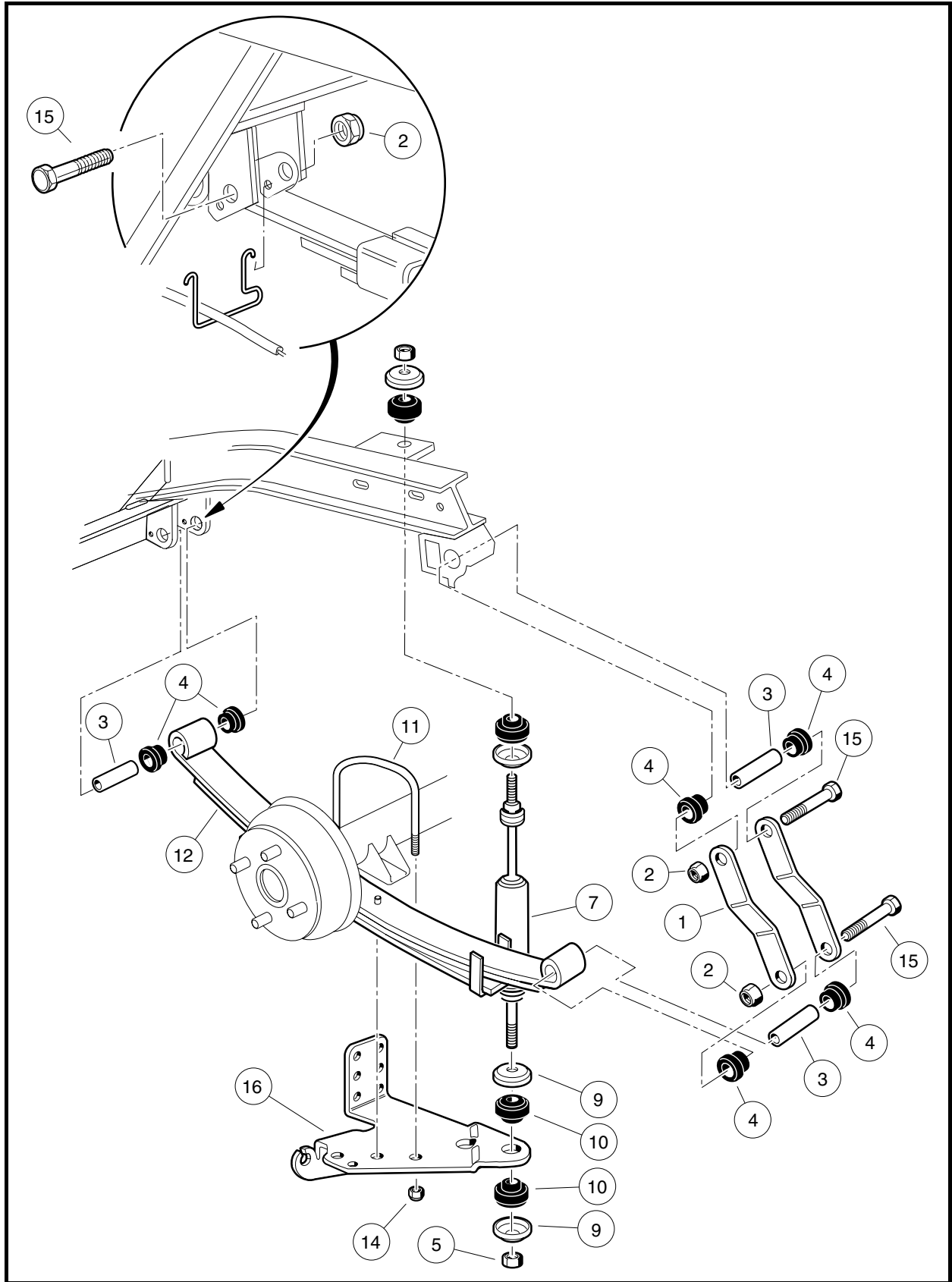

Figure 9-4 Rear Suspension Assembly and Mounting – 850

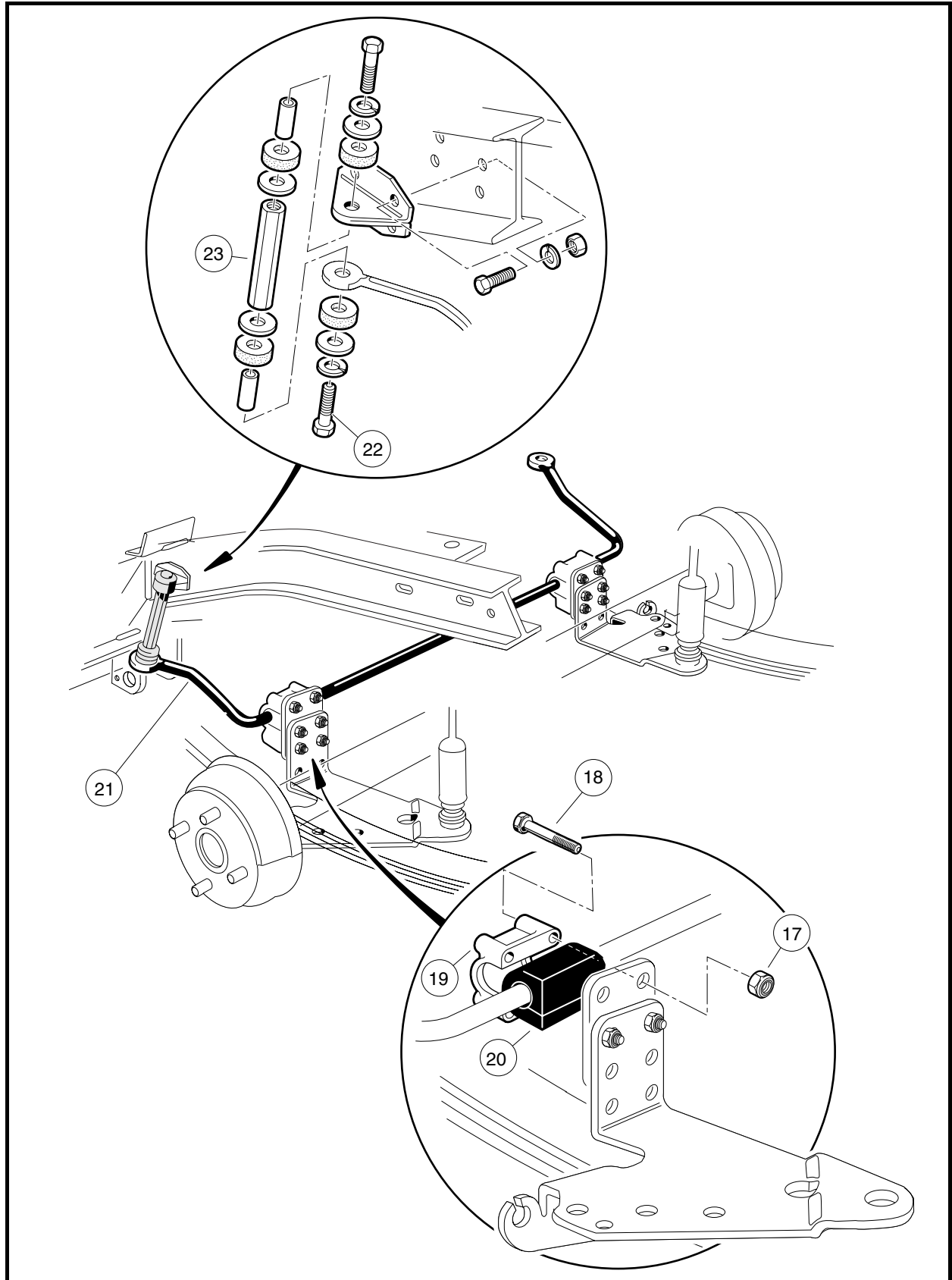

Figure 9-5 Rear Stabilizer Bar Mounting – 850

STABILIZER BAR REMOVAL

1. Loosen, but do not remove, lug nuts on tire and wheel assembly on the side from which the spring is to be removed. Place chocks at the front wheels and lift the rear of the vehicle with a chain hoist or floor jack. Position jack stands under the frame crossmember between the spring mount and the side stringer, just forward of each rear wheel. Lower the vehicle to let the jack stands support the vehicle (**Figure 9-1, Page 9-2**). See following **WARNING**.

▲ WARNING

- **Lift only one end of the vehicle at a time. Use a suitable lifting device (chain hoist or hydraulic floor jack) with 1000 lb. (454 kg) minimum lifting capacity. Do not use lifting device to hold vehicle in raised position. Use approved jack stands of proper weight capacity to support the vehicle and chock the wheels that remain on the floor. When not performing a test or service procedure that requires movement of the wheels, lock the brakes.**
2. Remove the tire and wheel assemblies.
 3. Remove the nuts (17), bolts (18) and bushing support (19) attaching the rear stabilizer bar (21) to the shock mount bracket (**Figure 9-5, Page 9-6**).
 4. Remove the bolts (22) attaching the ends of the rear stabilizer bar (21) to the links (23).

STABILIZER BAR INSTALLATION

1. To install the stabilizer bar, reverse the removal procedure.
2. Tighten the link bolts (22) to 180 in-lb (20.3 N·m).
3. Tighten the bushing support nuts (17) to 138 in-lb (15.6 N·m).
4. Install wheels and finger-tighten lug nuts.
5. Lower the vehicle and finish tightening lug nuts, using a crisscross pattern, to the following amounts:
 - 5.1. For vehicles with steel wheels, tighten the lug nuts to 55 ft-lb (74.6 N·m).
 - 5.2. For XRT 850 vehicles with alloy mag wheels, tighten the lug nuts to 65 ft-lb (88 N·m).

SECTION 10 – PERIODIC MAINTENANCE

GENERAL INFORMATION

See General Warning on page 1-1.

To ensure trouble-free vehicle performance, it is very important to follow an established preventive maintenance program (regularly scheduled service). Regular and consistent vehicle maintenance can prevent vehicle down-time and expensive repairs that result from neglect. Any vehicle not functioning correctly should be removed from use until it is properly repaired. This will prevent further damage to the vehicle and avoid the possibility of injury due to unsafe conditions.

Contact your local authorized distributor/dealer to perform all repairs and semiannual and annual periodic service.

PERIODIC SERVICE SCHEDULES

See General Warning on page 1-1.

WARNING

- **Service, repairs, and adjustments must be made per instructions in the maintenance and service manual.**
- **If any problems are found during scheduled inspection or service, do not operate the vehicle until repairs are made. Failure to make necessary repairs could result in fire, property damage, severe personal injury, or death.**

NOTE: *If the vehicle is constantly subjected to heavy use or severe operating conditions, the preventive maintenance procedure should be performed more often than recommended in the periodic service and lubrication schedules.*

Both the Periodic Service Schedule and Periodic Lubrication Schedule must be followed to keep vehicle in optimum operating condition.

PERIODIC SERVICE SCHEDULE – ELECTRIC VEHICLES		
REGULAR INTERVAL	SERVICE	
Daily service by owner	Pre-Operation and Daily Safety Checklist	See Pre-Operation and Daily Safety Checklist in the Owner's Manual.
	Performance Inspection	See Performance Inspection in the Owner's Manual.
	Batteries	Charge batteries (after each daily use only).
Weekly service by owner	Batteries	Check electrolyte level. Add water if necessary. See Battery Care on page 24-9.
Monthly service by owner or trained technician	Batteries	Wash battery tops and clean terminals with baking soda/water solution.
	Tires	Check air pressure and adjust if necessary. See Section 2 – Vehicle Specifications.
	General vehicle	Wash battery compartment and underside of vehicle.
Semiannual service by trained technician only (or every 50 hours of operation, whichever comes first)	Brake system	Check brake shoes; replace if necessary. See Section 6 – Wheel Brake Assemblies.
		Lubricate brake slides per Lubrication Schedule. See Section 6 – Wheel Brake Assemblies.
		Check brake cables for damage; replace if necessary.
	Electrical wiring and connections	Check for tightness and damage.
	Forward/Reverse switch	Check condition of contacts and wire connections. Make sure connections are tight.
	Front wheel alignment and camber	Check and adjust as required. See Section 7 – Steering and Front Suspension.
Annual service by trained technician only (or every 100 hours of operation, whichever comes first)	Motor controller output regulator (MCOR)	Check for loose hardware, cracks and other damage.
	Batteries	If batteries are not performing as expected, see Section 24 – Batteries: Electric Vehicles

PERIODIC SERVICE SCHEDULE – GASOLINE VEHICLES		
REGULAR INTERVAL	SERVICE	
Daily service by owner	Pre-Operation and Daily Safety Checklist	See Pre-Operation and Daily Safety Checklist in the Owner's Manual.
	Performance Inspection	See Performance Inspection in the Owner's Manual.
Monthly service by owner or trained technician	Engine	Check engine oil level; change if necessary. See Engine Oil – Gasoline Vehicles on page 10-6.
		Check engine cooling air intake; clean if necessary. Visually inspect the unshrouded area around engine exhaust for grass and debris, and clean if necessary.
	Tires	Check air pressure and adjust as necessary. See Section 2 – Vehicle Specifications.
	General vehicle	Wash engine compartment and underside of vehicle. Do not wash engine when hot.
Semiannual service by trained technician only (or every 50 hours of operation, whichever comes first)	Battery	Clean terminals and wash dirt from casing; check electrolyte level. See Battery on page 13-30.
	Front wheel alignment and camber	Check and adjust if necessary. See Section 7 – Steering and Front Suspension.
	Electrical wiring and connections	Check for tightness and damage.
	Brake system	Check brake shoes; replace if necessary.
		Lubricate brake slides. See Periodic Lubrication Schedules on page 4.
Check brake cables for damage; replace if necessary.		
Annual service by trained technician only (or every 100 hours of operation, whichever comes first)	Engine	Check for leaks around gaskets, fill plugs, etc.
		Inspect, clean and regap spark plug; replace if necessary.
	Engine air intake system	Check air filter element; clean or replace if necessary.
		Check clamps for tightness; check hose for cracks.
	General vehicle	Check for loose hardware and tighten if necessary.
Two year service by trained technician only (or every 200 hours of operation, whichever comes first)	Fuel filters	Replace. Dispose of used filters properly.

PERIODIC LUBRICATION SCHEDULES

PERIODIC LUBRICATION SCHEDULE – ELECTRIC VEHICLES			
REGULAR INTERVAL	SERVICE	LUBRICATION POINTS	RECOMMENDED LUBRICANT
Semiannually by owner or trained technician (or every 50 hours of operation, whichever comes first)	Brake pedal shaft bearings	1	Dry Moly Lube
	Brake linkage and pivots	2	Dry Moly Lube
	Accelerator pivot rod supports	3	Dry Moly Lube
	Charger receptacle	4	WD-40
	Brake slides	5	Dry Moly Lube
	Front suspension (5 fittings)	6	Chassis Lube – EP NLGI Grade 2
Annually by trained technician only (or every 100 hours of operation, whichever comes first)	Check/fill transaxle to plug level	7	22 oz. (0.67 L) SAE 30 WT. API Class SE, SF, or SG Oil (or higher)

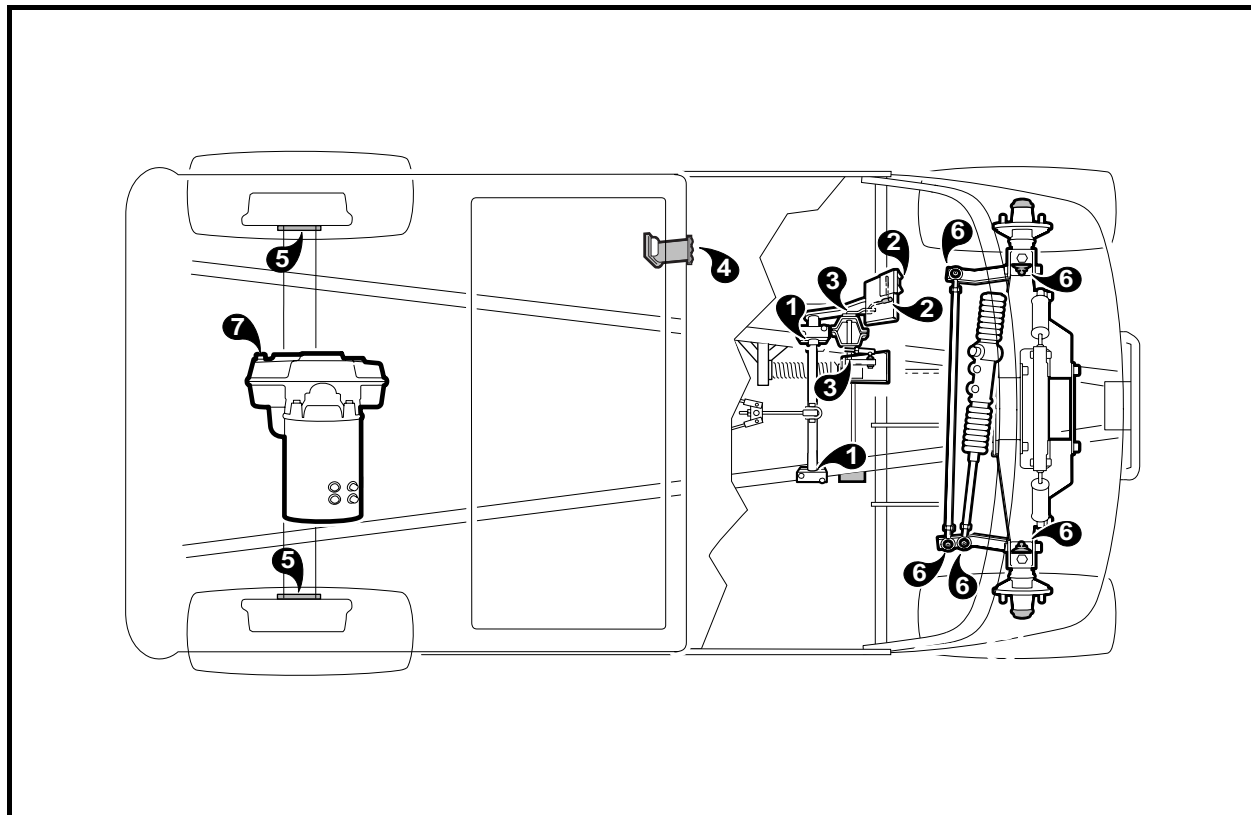

Figure 10-1 Lubrication Points – Electric Vehicles

PERIODIC LUBRICATION SCHEDULE – GASOLINE VEHICLES			
REGULAR INTERVAL	SERVICE	LUBRICATION POINTS	RECOMMENDED LUBRICANT
Semiannually by owner trained technician (or every 50 hours of operation, whichever comes first)	Brake pedal shaft bearings	1	Dry Moly Lube
	Brake linkage and pivots	2	Dry Moly Lube
	Accelerator push rod pivots, mounts, and shifter cable pivots	3	Dry Moly Lube
	Front suspension (5 fittings)	4	Chassis Lube
	Brake slides	5	Dry Moly Lube
Annually by trained technician only (or every 100 hours of operation, whichever comes first)	Check/fill unitized transaxle to plug level	6	27 oz. (0.8 L) 80-90 WT. API Class GL-3 or 80-90 WT. AGMA Class EP Gear Lube
First change 100 hours – additional change every 200 hours of operation, or annually, whichever comes first.	Change engine oil and oil filter	7	32 oz. (0.95 L) without filter; 38 oz. (1.12 L) with filter

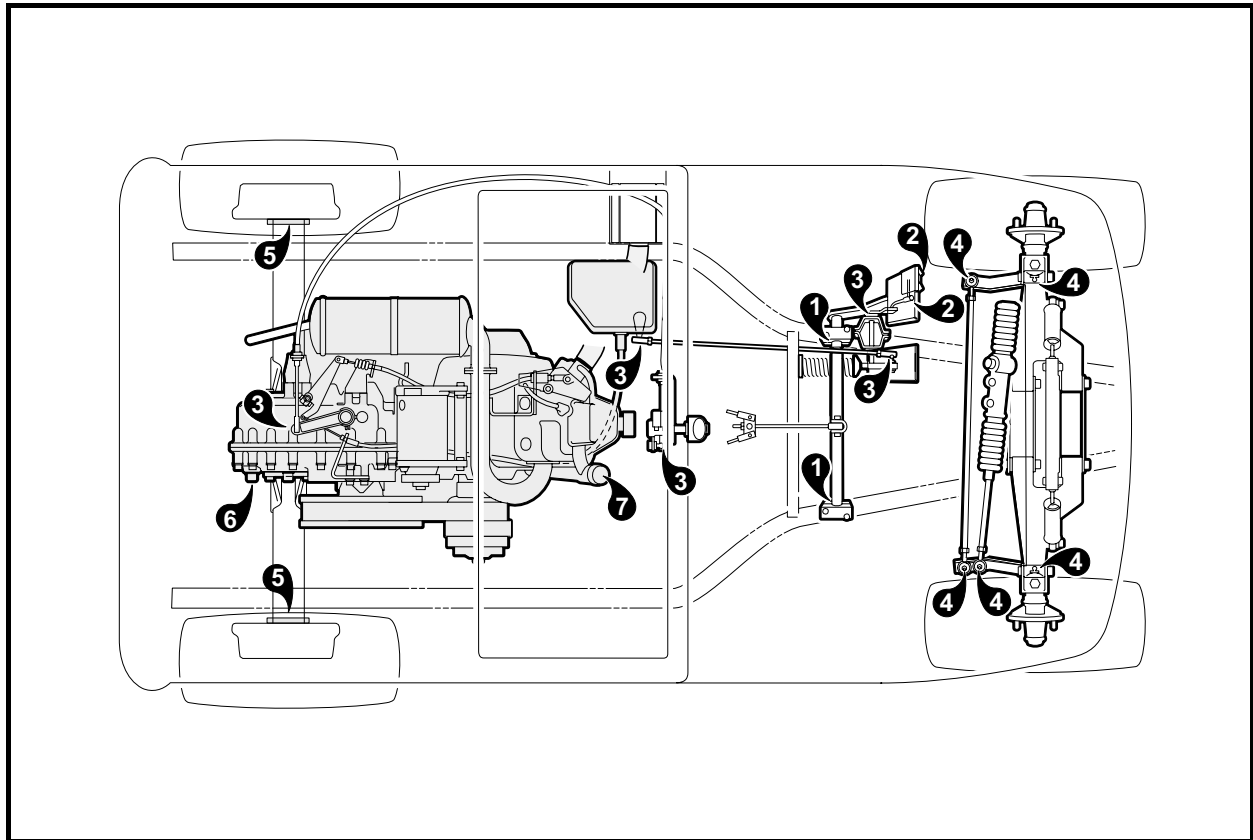

Figure 10-2 Lubrication Points – 800 and 810 Gasoline Vehicles

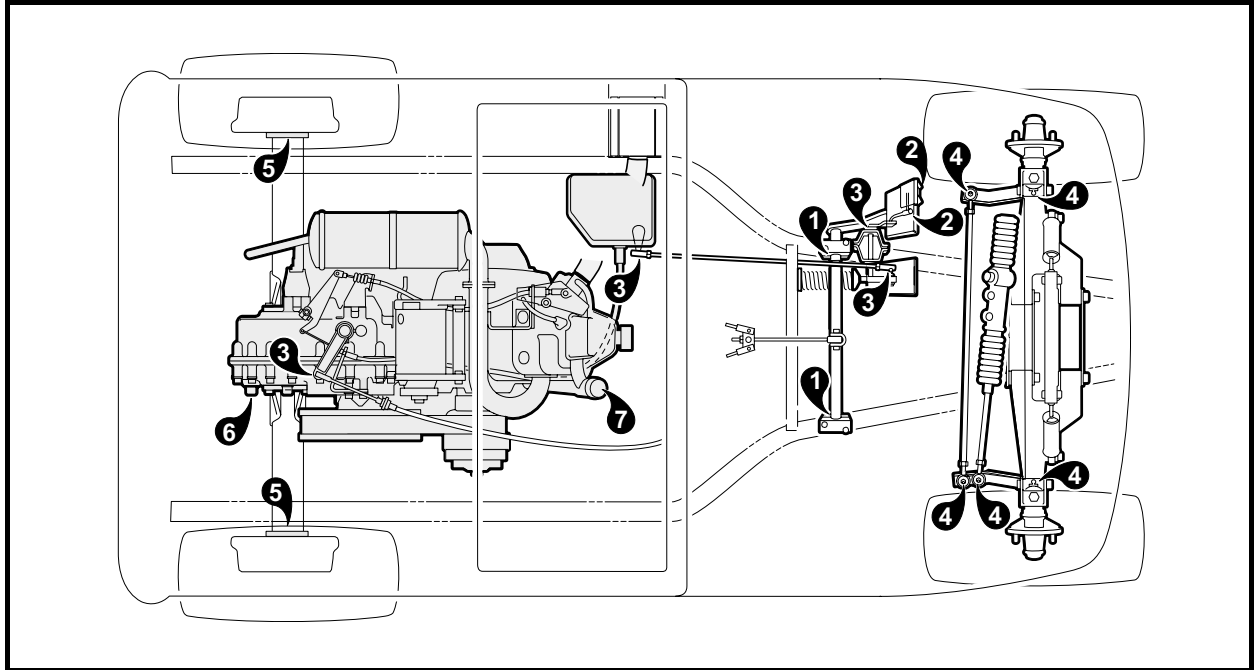

Figure 10-3 Lubrication Points – 850 Gasoline Vehicles

ENGINE OIL – GASOLINE VEHICLES

See General Warning on page 1-1.

Even though the low oil warning light on the dash should illuminate if oil level becomes low, engine oil level should be checked monthly. Vehicle should be on a level surface when checking oil. Do not overfill with oil.

ENGINE OIL LEVEL CHECK

1. Remove the oil level dipstick from the oil filler tube and wipe oil from dipstick (**Figure 10-4, Page 10-7**). See following **CAUTION**.

CAUTION

- Do not remove dipstick while engine is running.
2. Check oil by fully inserting the dipstick into the oil filler tube and immediately removing it.
 3. If the oil level is at or below the low level mark on the dipstick gauge, add oil until the level is between low and full levels (safe level).
 4. Reinsert dipstick into the oil filler tube.

NOTE: Properly recycle or dispose of used oil in accordance with local, state, and federal regulations.

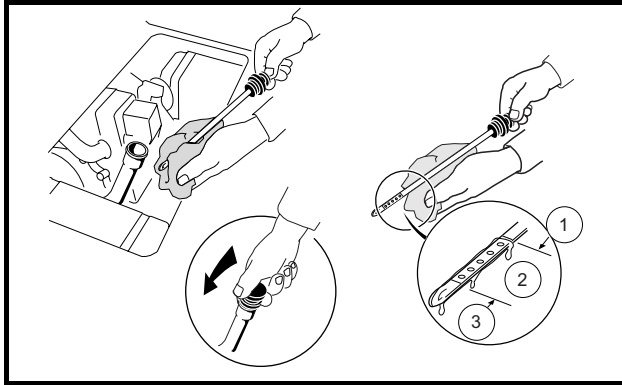

Figure 10-4 Engine Oil Level Check

1.Full level 2. Safe level 3. Low level.

ENGINE OIL AND FILTER CHANGE

Engine oil and oil filter should be changed after the first 100 hours of operation. After that, they should be changed every 200 hours of operation or annually, whichever comes first.

1. Turn the key switch to the OFF position, then remove the key. Place the Forward/Reverse handle in the NEUTRAL position. Chock the front wheels.
2. Access the engine compartment. **See following WARNING.**

⚠ WARNING

- For vehicles with cargo beds, remove all cargo before raising the bed or servicing the vehicle. If the vehicle is equipped with a prop rod, ensure that it is securely engaged while bed is raised. Do not close the bed until all persons are clear of cargo bed area. Keep hands clear of all crush areas. Do not drop cargo bed; lower gently and keep entire body clear. Failure to heed this warning could result in severe personal injury or death.

3. Disconnect the battery cables, negative (–) cable first. **See WARNING “To avoid unintentionally starting...” in General Warning on page 1-2.**
4. Position a pan designed for oil changes under the front drain plug (**Figure 10-5, Page 10-8**).
5. Use a 14 mm socket or wrench to remove the drain plug, turning it counterclockwise, and allow the engine oil to drain into the pan. **See following WARNING.**

⚠ WARNING

- Do not attempt to change engine oil when the engine is hot or even warm. Engine oil can cause skin burns.
 - Wear safety glasses or approved eye protection when servicing the vehicle. Wear rubber gloves when handling oil drain plug, oil filter, and oil drain pan.
6. Clean the oil drain plug threads with solvent to remove oil and oil residue. Make sure that the compression washer remains on the drain plug.
 7. Use a 14 mm socket or wrench and replace the front oil drain plug, turning it clockwise, and tighten to 18 ft-lb (24.4 N·m).

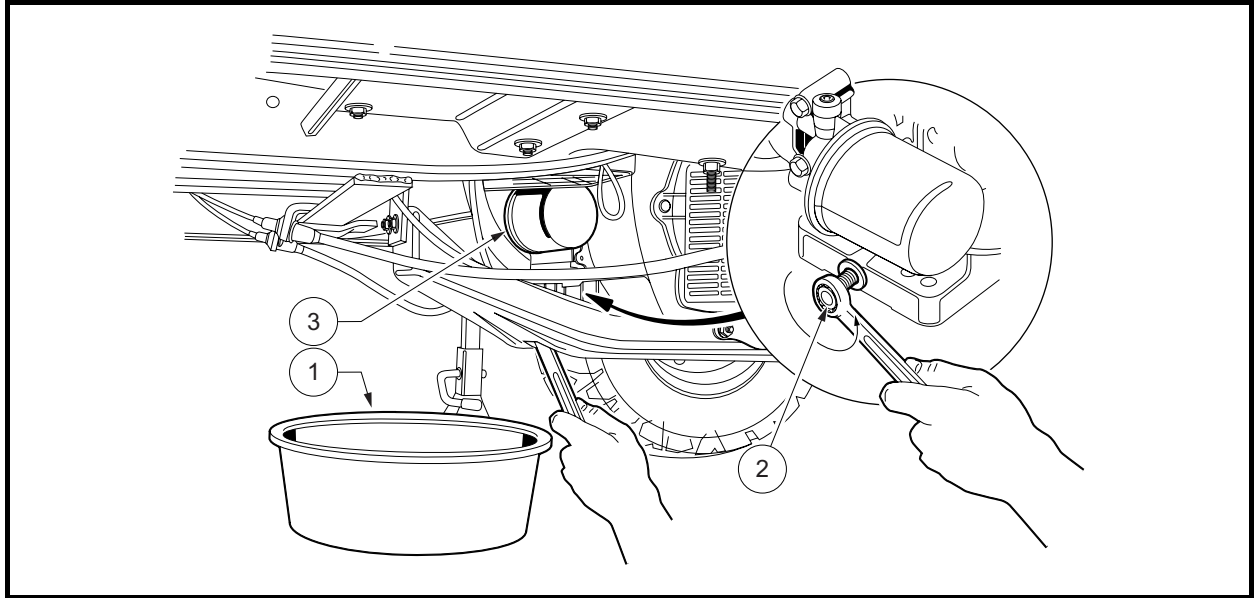

Figure 10-5 Engine Oil Drain Plug and Pan

1. Drain pan 2. Drain plug 3. Oil filter

8. Relocate the oil drain pan to a position under the engine oil filter (**Figure 10-5, Page 10-8**).
9. Remove the engine oil filter, turning it counterclockwise, allowing the residual oil in the filter port and filter to drain into the oil drain pan (**Figure 10-6, Page 10-9**). **See following NOTE.**

NOTE: An oil drip guard can be used to prevent excess oil from dripping into the engine base plate. Use an empty quart (one liter) container and cut the bottom off at an angle, then slide the open area of the container up and under the oil filter prior to removing. Position the port of the plastic container so oil will be directed into the oil pan (**Figure 10-5, Page 10-8**). Or, make a drip guard by folding a piece of cardboard, thin metal, or plastic under the oil filter forming a channel to direct the filter port oil into the drain pan.

Dispose of used oil according to the environmental laws and regulations for your area.

10. Use a clean rag and wipe the oil filter mounting bracket surface clean where the oil filter gasket seats.
11. Install a new oil filter (CCI P/N 1016467) onto the engine oil filter port. Apply a light coat of white lithium NLGI Number 2 grease (Dow Corning® BR2-Plus or equivalent) or new engine oil to the rubber seal around the outside surface of the filter before attaching it to the oil filter port (**Figure 10-7, Page 10-9**). This will help seal the filter to the oil mounting bracket. **See following NOTE.**

NOTE: Use only Club Car oil filters (CCI P/N 1016467) designed for this engine.

12. Tighten the oil filter by hand until tight. Do not use a band wrench or channel lock plier to tighten.
13. Remove the dipstick and add engine oil into the dipstick port. Use a funnel or pour spout to direct the oil into the dipstick port. With filter change, the engine requires 38 ounces (1.12 liters) of oil per change. Refer to oil viscosity guidelines for selection of oil grade (**Figure 10-8, Page 10-9**). Replace the dipstick.
14. Connect the battery cables, positive (+) cable first, and tighten terminals to 12 ft-lb (16 N·m). Coat terminals with Battery Terminal Protector Spray (CCI P/N 1014305).
15. Lower the cargo bed. **See WARNING “For vehicles with cargo beds...” on page 1-3.**

16. With the Forward/Reverse handle in the NEUTRAL position, start and run the engine for a few minutes. Observe both the drain plug and the oil filter from under the vehicle and watch for oil leaks. If leaks appear, begin with step 1 and repeat the appropriate step for either or both items to correct the problem.
17. Remove the dip stick and check the engine oil as a final step. Replace the dip stick.

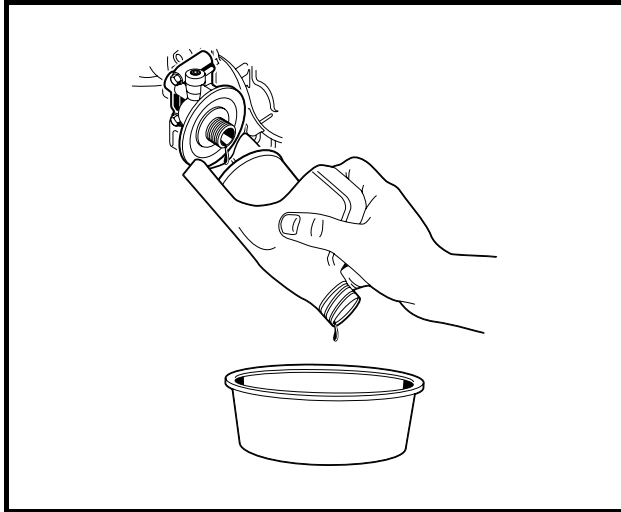

Figure 10-6 Remove Engine Oil Filter

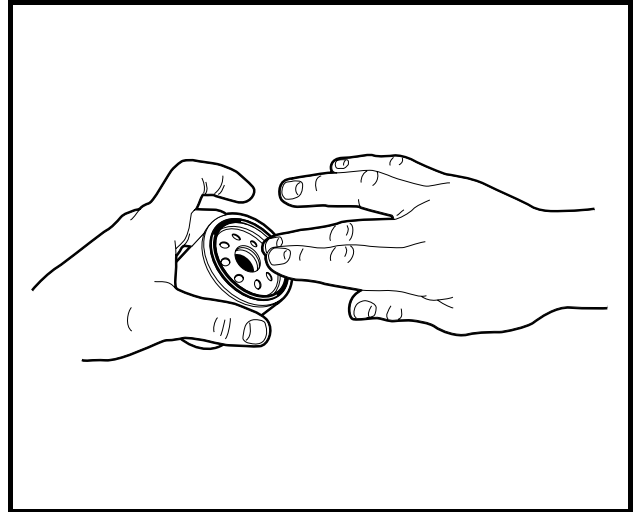

Figure 10-7 Coat Oil Filter Rubber Seal

OIL VISCOSITY

Choose the viscosity according to the temperature as indicated by the oil viscosity chart (Figure 10-8, Page 10-9). See following NOTE.

NOTE: Using multi-grade oils (5W-20, 10W-30, and 10W-40) will increase oil consumption. Check oil level more frequently when using them.

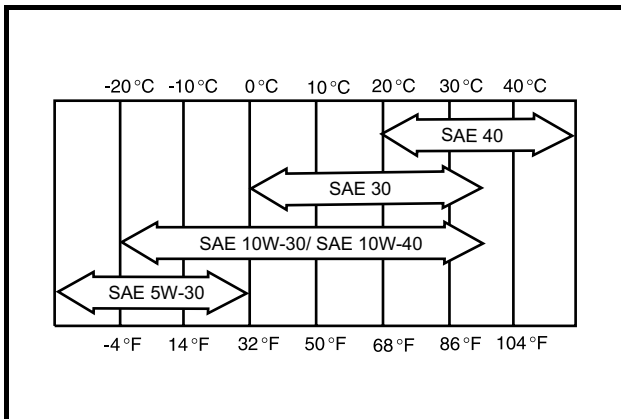

Figure 10-8 Oil Viscosity Chart

SECTION 11 – TROUBLESHOOTING AND ELECTRICAL SYSTEM: 800 AND 810 GAS

⚠ DANGER

- See General Warning on page 1-1.

⚠ WARNING

- See General Warning on page 1-1.

GENERAL INFORMATION

Section 11 contains the information required to correctly troubleshoot the vehicle. A troubleshooting guide is provided for general troubleshooting. For issues pertaining solely to the electrical system, proceed to Electrical System on page 11-5.

In addition to troubleshooting, this section contains general information on the electrical system and the electrical circuits of the system.

TROUBLESHOOTING GUIDE

The following troubleshooting guide will be helpful in identifying operating difficulties should they occur. The guide includes the symptom, probable cause(s) and suggested checks. The procedures used in making these checks can be found in the referenced sections of this maintenance and service manual.

TROUBLESHOOTING GUIDE		
SYMPTOM	POSSIBLE CAUSES	REFER TO
Engine does not start easily.	Spark plug is partially fouled or in poor condition	Section 15 – Engine
	Spark plug wire is damaged or loose	Section 15 – Engine
	Loose wire connection at ignition coil or RPM limiter	Section 11 – Troubleshooting and Electrical System: 800 and 810 Gas, Test Procedures 14, 15, and 16
	Intermittent ignition coil failure	Section 11 – Troubleshooting and Electrical System: 800 and 810 Gas, Test Procedures 14, 15, and 16
	Low cylinder compression	Section 15 – Engine
	Water or dirt in the fuel system and/or carburetor; dirty or clogged fuel filter	Section 16 – Fuel System: Gasoline Vehicle
	Carburetor improperly adjusted	Section 16 – Fuel System: Gasoline Vehicle
	Starter/generator belt is slipping	Section 13 – Electrical Components: 800 and 810 Gasoline Vehicles Belt Tension Adjustment on page 13-10
Troubleshooting Guide continued on next page...		

TROUBLESHOOTING GUIDE		
SYMPTOM	POSSIBLE CAUSES	REFER TO
Engine starts but does not run smoothly.	Spark plug is fouled or in poor condition	Section 15 – Engine
	Spark plug wire is damaged or loose	Section 15 – Engine
	Intermittent ignition coil failure	Section 11 – Troubleshooting and Electrical System: 800 and 810 Gas, Test Procedures 14, 15, and 16
	Water or dirt in the fuel system and/or carburetor; dirty or clogged fuel filter	Section 16 – Fuel System: Gasoline Vehicle
	Fuel pump malfunction; fuel pressure to carburetor too low	Section 16 – Fuel System: Gasoline Vehicle
Engine turns but fails to start.	Fuel tank is empty	Section 16 – Fuel System: Gasoline Vehicle
	Fuel line or filters clogged	Section 16 – Fuel System: Gasoline Vehicle
	Fouled spark plug	Section 15 – Engine
	Spark plug wire damaged or loose	Section 15 – Engine
	Loose wire connection at ignition coil or RPM limiter	Section 11 – Troubleshooting and Electrical System: 800 and 810 Gas, Test Procedures 14, 15, and 16
	Engine flooded with fuel as result of excess choking	See Owner's Manual, Controls and Indicators. See Choke.
	Fuel pump malfunction or failure	Section 16 – Fuel System: Gasoline Vehicle
	Ignition coil or RPM limiter failed	Section 11 – Troubleshooting and Electrical System: 800 and 810 Gas, Test Procedures 14, 15, and 16
	Kill circuit grounded	Section 11 – Troubleshooting and Electrical System: 800 and 810 Gas, Test Procedures 17 and 18
Engine overheats.	Fan screen is partially blocked or plugged	See the Engines and Transaxles manual (CCI P/N 102396501)
	Governor is improperly adjusted	Section 16 – Fuel System: Gasoline Vehicle
	Carburetor is too lean; check main jet size	Section 16 – Fuel System: Gasoline Vehicle
Engine pre-ignites.	Excessive carbon deposits on piston head or in combustion chamber	See the Engines and Transaxles manual (CCI P/N 102396501)
	Spark plug heat range is incorrect	Section 15 – Engine
	Unsuitable or contaminated fuel	Section 16 – Fuel System: Gasoline Vehicle
Loss of engine power.	Exhaust valve is restricted with carbon deposit	See the Engines and Transaxles manual (CCI P/N 102396501)
	Muffler or exhaust pipe restricted with carbon or other substance	Section 17 – Exhaust System: Gasoline Vehicles
	Ignition coil failed	Section 11 – Troubleshooting and Electrical System: 800 and 810 Gas, Test Procedures 14, 15, and 16
	Air filter is dirty or clogged	Section 16 – Fuel System: Gasoline Vehicle
	Governor is improperly adjusted	Section 16 – Fuel System: Gasoline Vehicle
Troubleshooting Guide continued on next page...		

TROUBLESHOOTING GUIDE		
SYMPTOM	POSSIBLE CAUSES	REFER TO
Loss of engine power (continued).	Throttle linkage out of adjustment	Section 16 – Fuel System: Gasoline Vehicle
	Low cylinder compression	Section 15 – Engine
	Spark plug failed	Section 15 – Engine
	Restricted fuel flow	Section 16 – Fuel System: Gasoline Vehicle
	Torque converter is not backshifting properly	Section 20 – Torque Converter: Gasoline Vehicle
Spark plug fouls repeatedly.	Incorrect plug	Section 15 – Engine
	Unsuitable fuel, or incorrect (rich) fuel mixture	Section 15 – Engine
	Spark plug wire is damaged	Section 15 – Engine
	Dirt entering combustion chamber	Section 16 – Fuel System: Gasoline Vehicle
	Ignition coil failed	Section 11 – Troubleshooting and Electrical System: 800 and 810 Gas, Test Procedures 14, 15, and 16
	Rings are heavily worn, low cylinder pressure	See the Engines and Transaxles manual (CCI P/N 102396501)
Carburetor floods.	Inlet valve or seat is leaking, dirty, worn, or damaged	Section 16 – Fuel System: Gasoline Vehicle
	Float is damaged and filled with gasoline	Section 16 – Fuel System: Gasoline Vehicle
	Carburetor vent is clogged	Section 16 – Fuel System: Gasoline Vehicle
	Float needle valve not functioning properly	Section 16 – Fuel System: Gasoline Vehicle
Starter fails to operate.	Lockout cam is in the wrong position	Section 11 – Troubleshooting and Electrical System: 800 and 810 Gas, Lockout Cam on page 11-5
	Fuse is blown	Section 11 – Troubleshooting and Electrical System: 800 and 810 Gas, Test Procedure 2
	Battery is dead	Section 11 – Troubleshooting and Electrical System: 800 and 810 Gas, Test Procedure 1
	Starter control circuit is not operating	Section 11 – Troubleshooting and Electrical System: 800 and 810 Gas, Test Procedure 8
	Starter/generator failed	Section 11 – Troubleshooting and Electrical System: 800 and 810 Gas, Test Procedure 8
	Starter solenoid failed	Section 11 – Troubleshooting and Electrical System: 800 and 810 Gas, Test Procedure 6
	Key switch failed	Section 11 – Troubleshooting and Electrical System: 800 and 810 Gas, Test Procedure 4
	Lockout limit switch failed	Section 11 – Troubleshooting and Electrical System: 800 and 810 Gas, Test Procedure 7
	Loose or broken wire in starter/generator circuit	Starter/Generator on page 13-1
Troubleshooting Guide continued on next page...		

TROUBLESHOOTING GUIDE		
SYMPTOM	POSSIBLE CAUSES	REFER TO
Starter fails to operate (continued).	Cylinder and/or crankcase flooded with fuel	Section 16 – Fuel System: Gasoline Vehicle
Starter/Generator does not charge battery.	Diode failed (open condition)	Section 11 – Troubleshooting and Electrical System: 800 and 810 Gas, Test Procedure 10
	Loose or broken wire in the starter/generator circuit	Section 11 – Troubleshooting and Electrical System: 800 and 810 Gas, Test Procedure 11
	Generator field coil is shorted	Section 11 – Troubleshooting and Electrical System: 800 and 810 Gas, Test Procedure 11
	Brushes are worn or commutator is dirty	Starter/Generator on page 13-1
	Starter/generator belt is loose or slipping	Belt Tension Adjustment on page 13-10
	Voltage regulator failed	Section 11 – Troubleshooting and Electrical System: 800 and 810 Gas, Test Procedure 12
	Battery failed	Section 11 – Troubleshooting and Electrical System: 800 and 810 Gas, Test Procedure 1
Transmission does not engage or disengage smoothly.	Transmission shifter linkage is binding or is out of adjustment	Forward/Reverse Shifter Cable Adjustment on page 18-20
	Idle RPM Setting is set too high	Section 16 – Fuel System: Gasoline Vehicle
	Insufficient (low) level of lubricant or wrong type of lubricant in transmission	Lubrication on page 18-2
	Internal gears are damaged or worn	See the Engines and Transaxles manual (CCI P/N 102396501)
	Synchronizer rings are worn, damaged or jammed	See the Engines and Transaxles manual (CCI P/N 102396501)
Excessive vehicle vibration.	Engine mounting nuts or bolts are loose	Section 15 – Engine
	Snubber on frame is worn or damaged	Section 15 – Engine
	Misaligned muffler mounting clamp	Section 17 – Exhaust System: Gasoline Vehicles
	Damaged drive belt or starter belt	Section 20 – Torque Converter: Gasoline Vehicle
	Damaged drive clutch	Section 20 – Torque Converter: Gasoline Vehicle
	Damaged driven clutch	Section 20 – Torque Converter: Gasoline Vehicle
	Damaged starter/generator pulley	Starter/Generator Removal on page 13-1
	RPM setting is incorrect	Engine RPM Adjustment on page 16-12
Torque converter does not shift smoothly.	Drive belt is worn, cracked, glazed, or frayed	Drive Belt on page 20-2
	Drive clutch malfunction	Driven Clutch Inspection on page 20-13
	Driven clutch malfunction	Driven Clutch Inspection on page 20-13
	Governor is sticking	See the Engines and Transaxles manual (CCI P/N 102396501)
Engine won't stop running.	Kill circuit wire is disconnected from the ignition coil	Section 11 – Troubleshooting and Electrical System: 800 and 810 Gas, Test Procedure 13
Troubleshooting Guide continued on next page...		

TROUBLESHOOTING GUIDE		
SYMPTOM	POSSIBLE CAUSES	REFER TO
Engine won't stop running (continued).	Key switch failure	Section 11 – Troubleshooting and Electrical System: 800 and 810 Gas, Test Procedures 4 and 17
	Carburetor is too lean; check main and pilot jet sizes	Section 16 – Fuel System: Gasoline Vehicle
	Carburetor throttle stop screw out of adjustment	Section 16 – Fuel System: Gasoline Vehicle

ELECTRICAL SYSTEM

The electrical system on the gasoline key-start vehicles is 12 volts DC with negative ground to frame. It consists of ten circuits that are easily identified:

- Starter Circuit
- Generator Circuit
- Engine Ignition Circuit
- Engine Kill Circuit
- Reverse Buzzer Circuit
- Low Oil Warning Circuit
- Lockout Cam Circuit
- Fuel Gauge and Sending Unit Circuit
- Hour Meter Circuit
- Lighting Circuit

A key-start with neutral rev vehicle uses the ignition key to activate the electrical system and start the engine. It allows the engine to run at idle or advanced RPM using the accelerator pedal when the Forward/Reverse handle is in the NEUTRAL position. **See Section 15 – Engine.**

LOCKOUT CAM

This key-start vehicle is equipped with a lockout cam that allows the engine to be started and revved only when the Forward/Reverse handle is in the NEUTRAL position. The lockout cam (yellow) is located on the back of the Forward/Reverse handle, inside the engine compartment.

NOTE: Be sure the cam is in the correct position. The cam should activate the limit switch only when the Forward/Reverse handle is in the NEUTRAL position (**Figure 11-1, Page 11-5**).

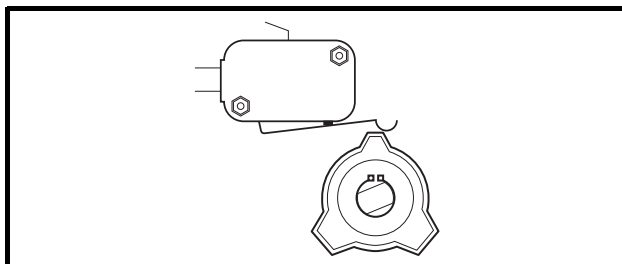

Figure 11-1 OPERATE (Neutral) Position for Cam

WIRING DIAGRAMS

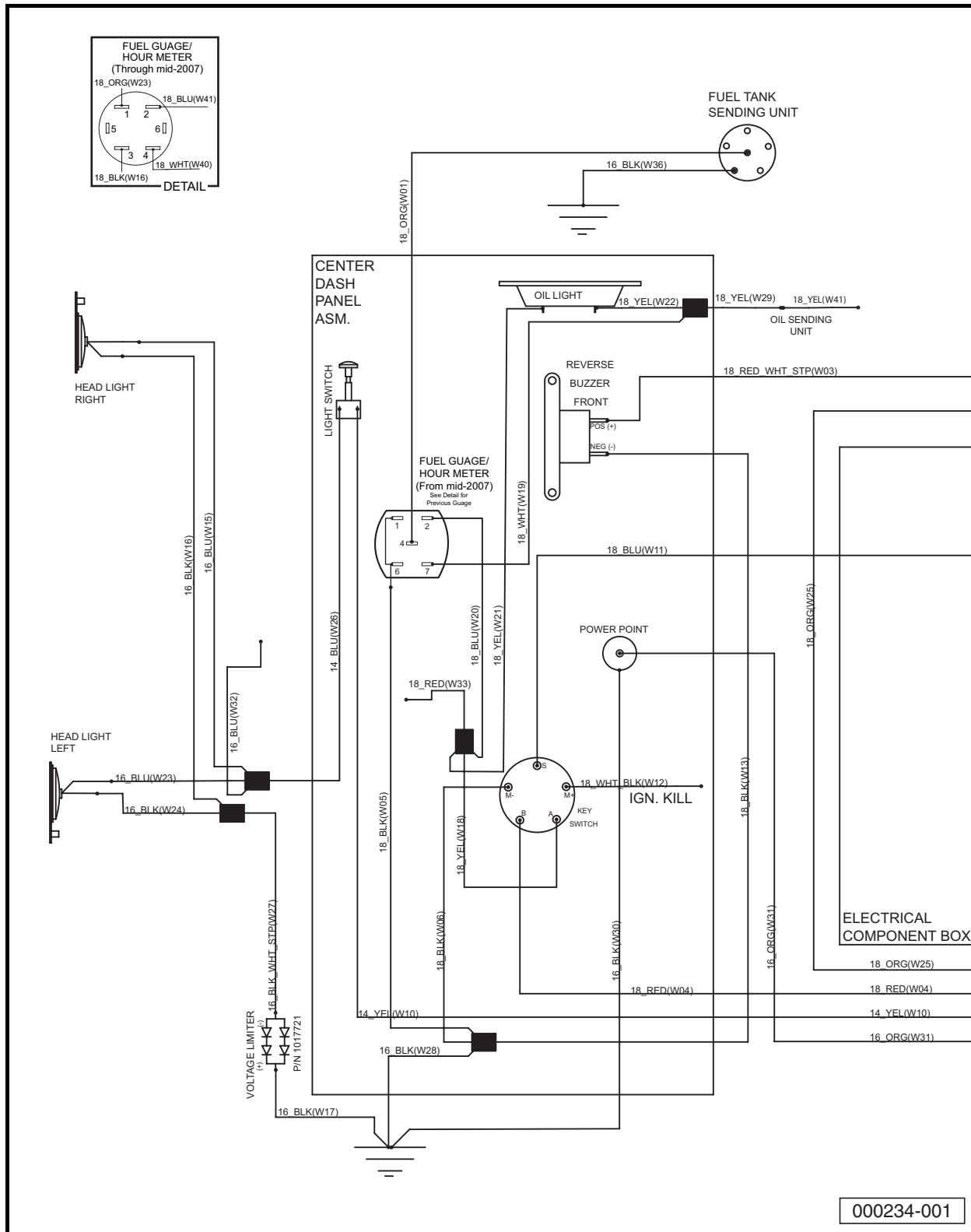
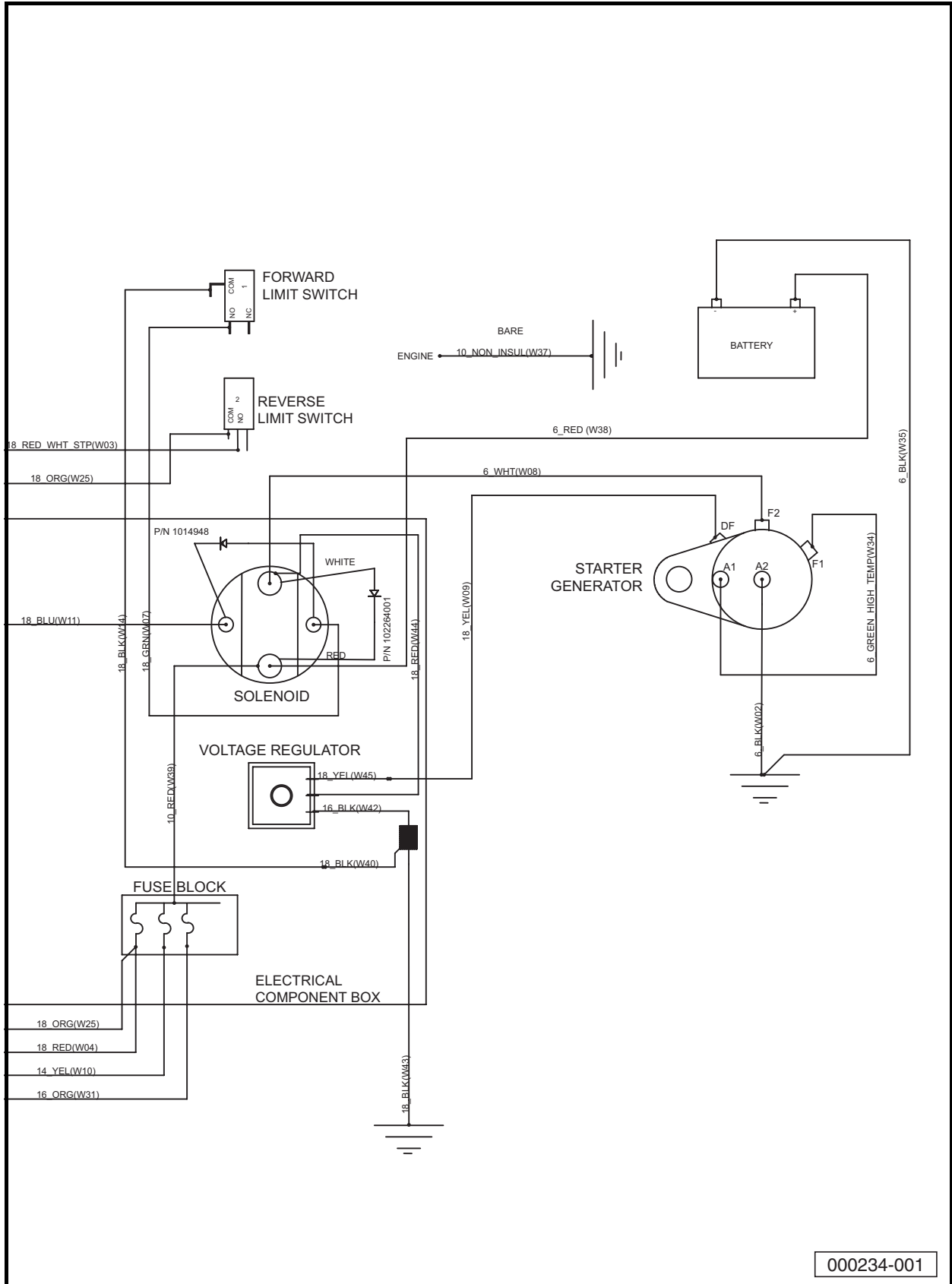

Figure 11-2 Wiring Diagram for Key-Start Gasoline Vehicles



000234-001

Figure 11-3 Wiring Diagram for Key-Start Gasoline Vehicles

TEST PROCEDURES

INDEX OF TEST PROCEDURES

1. Battery
2. Fuse
3. Ground Cables
4. Key Switch (Starter Circuit)
5. Key Switch (Accessory Terminal)
6. Solenoid
7. Lockout Cam Limit Switch
8. Starter/Generator (Starter Function)
9. Wire Continuity
10. Diode (Generator Circuit)
11. Starter/Generator (Generator Function)
12. Voltage Regulator
13. Grounded Kill Wire
14. Ignition Spark
15. RPM Limiter
16. Ignition Coil
17. Key Switch (Engine Kill Circuit)
18. Engine Kill Wire
19. Reverse Buzzer Limit Switch
20. Reverse Buzzer
21. Oil Level Sensor
22. Oil Warning Light
23. Lockout Cam
24. Battery Test (Under Load)
25. Fuel Level Sending Unit
26. Fuel Gauge
27. Hour Meter
28. Light Switch
29. Headlight Diode
30. Voltage at Headlight Socket

TEST PROCEDURE 1 – BATTERY

See General Warning on page 1-1.

⚠ DANGER

- Due to the danger of an exploding battery, wear a full face shield and rubber gloves when working around a battery.
- Battery – Explosive gases! Do not smoke. Keep sparks and flames away from the vehicle and service area. Ventilate when charging or using in an enclosed space. Wear a full face shield and rubber gloves when working on or near batteries. For added protection, cover top of the battery when servicing the vehicle.
- Battery – Poison! Contains acid! Causes severe burns! Avoid contact with skin, eyes, or clothing.
 - External: Flush with water. Call a physician immediately.
 - Internal: Drink large quantities of milk or water. Follow with milk of magnesia or vegetable oil. Call a physician immediately.
 - Eyes: Flush with water for 15 minutes. Call a physician immediately.

NOTE: The battery must be properly maintained and fully charged in order to perform the following test procedures. Battery maintenance procedures, including watering information and allowable mineral content, can be found in Section 13 of this manual. See **Battery, Section 13, Page 13-30**.

1. Turn the key switch OFF and remove the key. Place the Forward/Reverse handle in the NEUTRAL position. Chock the wheels.
2. Check for loose or corroded battery terminal connections. Clean, tighten and replace connections as necessary.

Hydrometer Test

A hydrometer (CCI P/N 1011478) measures the specific gravity. The higher the specific gravity, the higher the state of charge of the battery. A fully charged battery should read between 1.250 and 1.280 at 80 °F (27 °C). Never add acid to the battery to obtain a higher specific gravity (**Figure 11-4, Page 11-10**). See following **CAUTION**.

CAUTION

- Do not allow battery acid from battery caps or hydrometer to drip onto the body. Battery acid will cause permanent damage. Wash off immediately.

Performing the Hydrometer Test

1. Be sure that the battery has sufficient water to cover the plates by approximately 1/2-inch (13 mm) and is fully charged prior to beginning the test. If water must be added, recharge the battery before performing the hydrometer test (**Figure 11-5, Page 11-10**).
2. Remove the vent cap.
3. Using a battery thermometer (CCI P/N 1011767), record the electrolyte temperature of a center cell.
4. Squeeze the rubber bulb of the hydrometer and insert into the cell. Slowly release the bulb, drawing electrolyte up into the glass tube of the hydrometer.
5. When the float rises off the bottom, adjust the electrolyte level so that the float rides free of the bottom but does not strike the bottom of the rubber bulb. Remove the hydrometer from the cell and release the pressure from the bulb.

6. Hold the hydrometer vertically, ensuring that the float is not contacting the sides of the glass tube. Hold the hydrometer at eye level and read the scale at the level of electrolyte (**Figure 11-4, Page 11-10**).
7. Record the reading.
8. Return the electrolyte to the cell from which it was taken. Replace vent cap.
9. Repeat steps 2 through 8 on all cells.

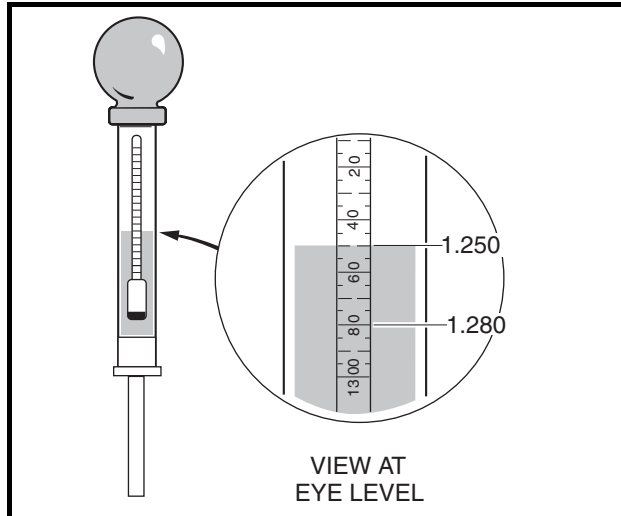

Figure 11-4 Hydrometer Test

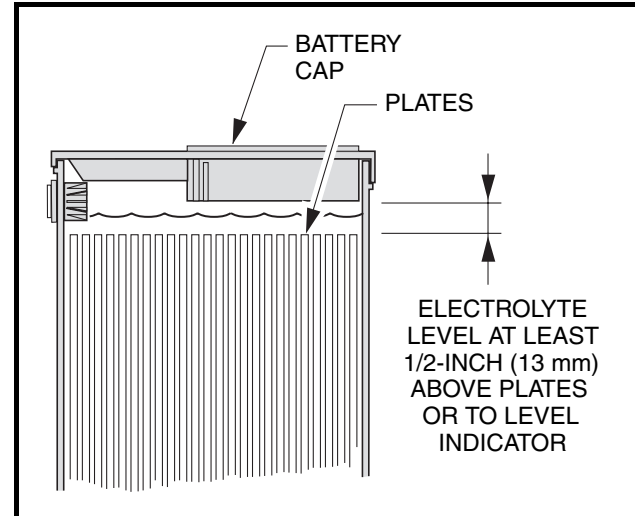

Figure 11-5 Battery Electrolyte Level

Hydrometer Calibration

Most hydrometers are calibrated to read correctly at 80 °F (27 °C). The readings obtained as described above must be corrected for temperature. For each 10 °F (5.6 °C) above 80 °F (27 °C), add 0.004 to the reading. For each 10 °F (5.6 °C) below 80 °F (27 °C), subtract 0.004 from the reading.

Interpreting the Results of the Hydrometer Test

The approximate state of charge can be determined by referring to the following table:

SPECIFIC GRAVITY (TEMPERATURE CORRECTED)	APPROXIMATE STATE OF CHARGE
1.250-1.280	100%
1.220-1.240	75%
1.190-1.210	50%
1.160-1.180	25%

If the difference between the cells is 0.020 or more, the low cell should be suspected. It may require a catch-up charge or it may be a weak cell. When the variations between cells reach 0.050 or more, the battery should be replaced.

Voltage Test

1. Place the red (+) probe of a multimeter set at Volts DC, 20 volt range, on the positive (+) cable and place the black (-) probe on the negative (-) post of the battery and take a voltage reading. If it shows less than 12.4 volts, or if the lowest specific gravity reading from the hydrometer test is less than 1.225, recharge the battery. If battery voltage is greater than 12.4 volts and specific gravity is greater than 1.225, the problem is not with the battery. If the battery does not reach 12.4 volts, or if the specific gravity of a cell is still less than 1.225 after charging, replace the battery. **See following NOTE.**

NOTE: A fully charged battery that is in good condition should have a specific gravity of at least 1.225 in all cells, and the difference in the specific gravity of any two cells should be less than 50 points. Open circuit voltage should be at least 12.4 volts.

Load Test

1. Connect a 160-ampere load tester to the battery posts.
2. Turn the switch on the load tester to the ON position.
3. Read the battery voltage after the load tester has been turned ON for 15 seconds. Compare the battery's voltage reading with the table below. Make sure you have the correct ambient temperature.
4. If the battery is found to be good, or if the electrical problem continues after the battery has been replaced with a good one, test the electrical circuits.

IF TEMPERATURE IS	MINIMUM CRANKING VOLTAGE
70 °F (20 °C) and above	9.6 V
60 °F (16 °C)	9.5 V
50 °F (10 °C)	9.4 V
40 °F (4 °C)	9.3 V
30 °F (-1 °C)	9.1 V
20 °F (-7 °C)	8.9 V
10 °F (-12 °C)	8.7 V
0 °F (-18 °C)	8.5 V

TEST PROCEDURE 2 – FUSE

See General Warning on page 1-1.

The fuse (red 10 amp) is located in the electrical component box.

1. Turn the key switch OFF and remove the key. Place the Forward/Reverse handle in the NEUTRAL position. Chock the wheels.
2. Disconnect the battery cables as instructed. **See WARNING “To avoid unintentionally starting...” in General Warning on page 1-2.**
3. Remove the cover on the electrical component box.
4. Check that wires are connected correctly and are tight. If they are not, rewire or tighten as necessary.
5. Remove fuse to be tested from the fuse block. **See Fuse Removal, Section 13, Page 13-16.** The red 10 amp fuse protects the solenoid for the starter (cranking) circuit. The 20 amp fuse at the yellow wire connection protects the headlights.

6. Connect the probes of a multimeter set to 200 ohms to the fuse terminals. The reading should be continuity. If there is no continuity, determine and repair the cause of the fuse failure. Replace the fuse with a properly rated new one.

TEST PROCEDURE 3 – GROUND CABLES

See **General Warning** on page 1-1.

1. Turn the key switch OFF and remove the key. Place the Forward/Reverse handle in the NEUTRAL position. Chock the wheels.
2. Disconnect the battery cables as instructed. See **WARNING “To avoid unintentionally starting...”** in **General Warning** on page 1-2.
3. Check the starter/generator ground strap.
 - 3.1. Set the multimeter to 200 ohms. Place the red (+) probe on the (A2) terminal of the starter/generator and place the black (–) probe on the vehicle frame (**Figure 11-6, Page 11-12**). The reading should be continuity. If the reading is incorrect, clean and tighten wire connections. If the connections are good and the reading is incorrect, repair or replace the wire.
4. Check the engine ground strap.
 - 4.1. Place the red (+) probe of the multimeter on the ground strap terminal end located on the oil filler bracket on the engine (**Figure 11-7, Page 11-12**). Place the black (–) probe on the vehicle frame. The reading should be continuity. If the reading is incorrect, clean and tighten wire connections. If the connections are good and the reading is incorrect, repair or replace the wire.

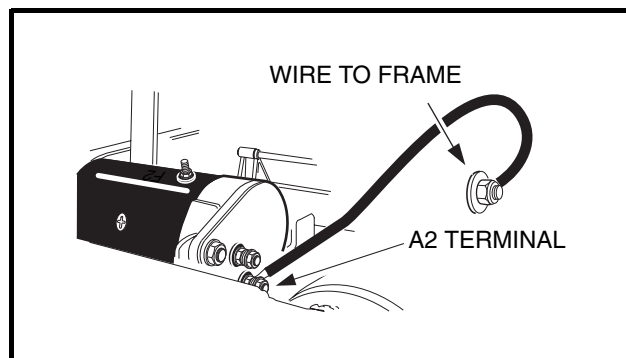

Figure 11-6 Test Starter/Generator Ground Strap

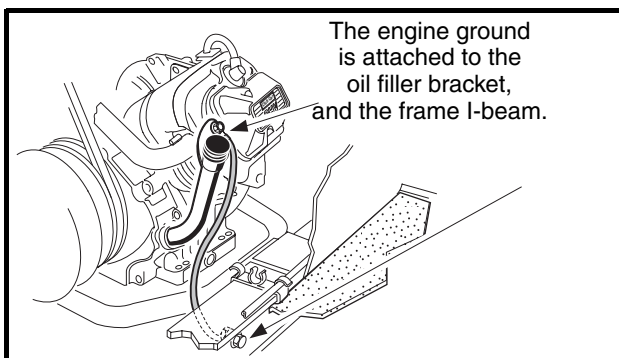

Figure 11-7 Test Engine Ground Strap

5. Check voltage regulator ground connection (at battery frame ground). Make sure it is clean and tight.
6. Check the battery ground cable.
 - 6.1. A 6-gauge black wire connects the negative battery post to the frame. The frame connection should be clean and tight. Visual inspection of the connection on the frame is very difficult. The best check for tightness is to pull on the black wire. If the wire moves at the connection end, disassemble the frame connection and clean the bolt, ring terminal, and nut. Install the frame connection.
 - 6.2. Set the multimeter to 200 ohms. Place the red (+) probe on the unconnected end of the 6-gauge black wire, and place the black (–) probe on the vehicle frame (**Figure 11-8, Page 11-13**). The reading should be continuity. If the reading is incorrect, check that terminal connections are clean and tight. If the connections are good and the reading is incorrect, repair or replace the wire.

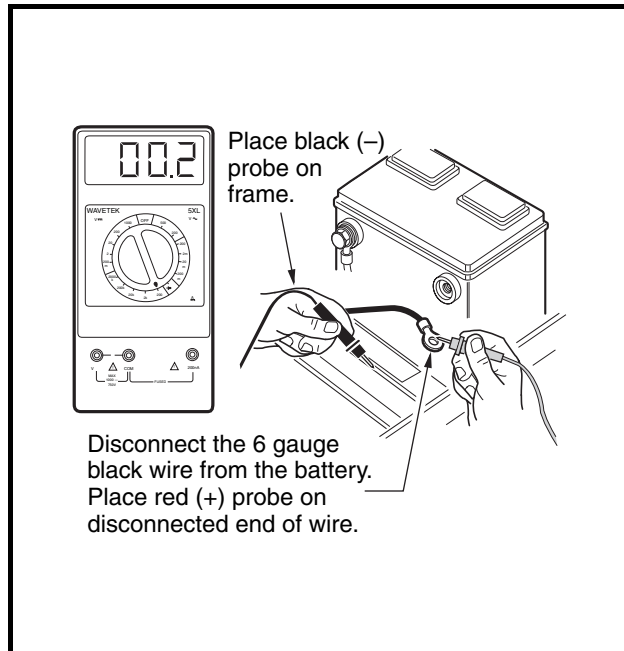

Figure 11-8 Battery Ground Cable Test

TEST PROCEDURE 4 – KEY SWITCH (STARTER CIRCUIT)

See **General Warning** on page 1-1.

1. Turn the key switch OFF and remove the key. Place the Forward/Reverse handle in the NEUTRAL position. Chock the wheels.
2. Disconnect the battery cables as instructed. See **WARNING “To avoid unintentionally starting...” in General Warning on page 1-2.**
3. Remove the instrument panel. See **Key Switch Removal, Section 13, Page 13-14.**
4. Ensure that the connector is connected correctly and is tight. If it is not, repair or replace as necessary.
5. Insert the key and turn the key to ON. Place the red (+) probe of the multimeter on the (B) terminal and the black (-) probe on the (L) terminal of the key switch. The reading should be continuity. If the reading is incorrect, replace the key switch (**Figure 11-9, Page 11-14**). See **Key Switch Removal, Section 13, Page 13-14.**
6. With the key still in the ON position, place the red (+) probe of the multimeter on the (B) terminal and the black (-) probe on the (S) terminal of the key switch. The reading should show no continuity. If the reading is incorrect, replace the key switch. See **Key Switch Removal, Section 13, Page 13-14.** If the reading is correct, leave the probes connected and proceed to the next step.
7. Insert the key and hold the key in the START position. The reading should be continuity. If the reading is incorrect, replace the key switch (**Figure 11-10, Page 11-14**). With the red (+) probe of the multimeter on the (B) terminal and the black (-) probe on the (L) terminal of the key switch, the reading should be continuity. If either reading is incorrect, replace the key switch. See **Key Switch Removal, Section 13, Page 13-14.**

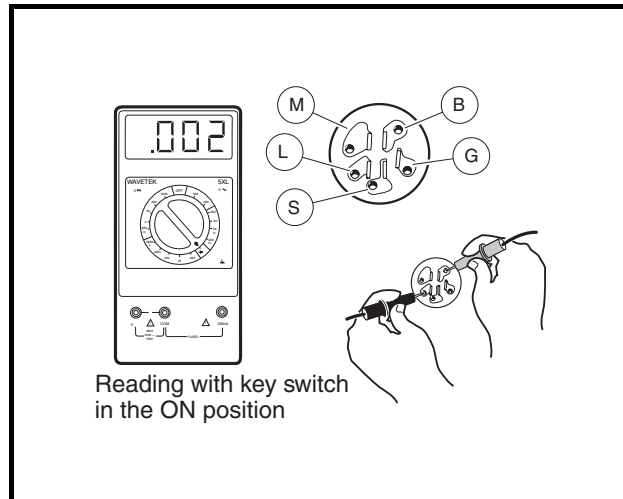

Figure 11-9 Key Switch Test – Accessory Terminal

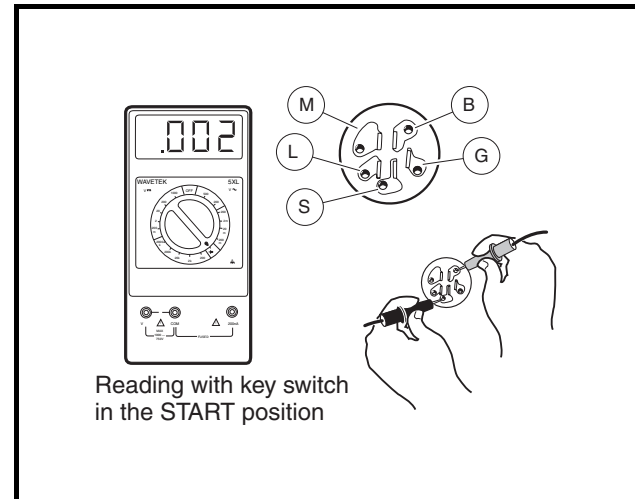

Figure 11-10 Key Switch Test – Starter Circuit

TEST PROCEDURE 5 – KEY SWITCH (ACCESSORY TERMINAL)

See **General Warning** on page 1-1.

1. Turn the key switch OFF and remove the key. Place the Forward/Reverse handle in the NEUTRAL position. Chock the wheels.
2. Disconnect the battery cables as instructed. See **WARNING “To avoid unintentionally starting...”** in **General Warning** on page 1-2.
3. Remove the instrument panel. See **Key Switch Removal, Section 13, Page 13-14.**
4. Ensure that the connector is connected correctly and is tight. If it is not, repair or replace as necessary.
5. Insert the key and turn the switch to the ON position. With the multimeter set to 200 ohms, place the red (+) probe of the multimeter on the (B) terminal and the black (–) probe on the (L) terminal of the key switch (**Figure 11-9, Page 11-14**). The reading should be continuity. If the reading is incorrect, replace the key switch. See **Key Switch Removal, Section 13, Page 13-14.**

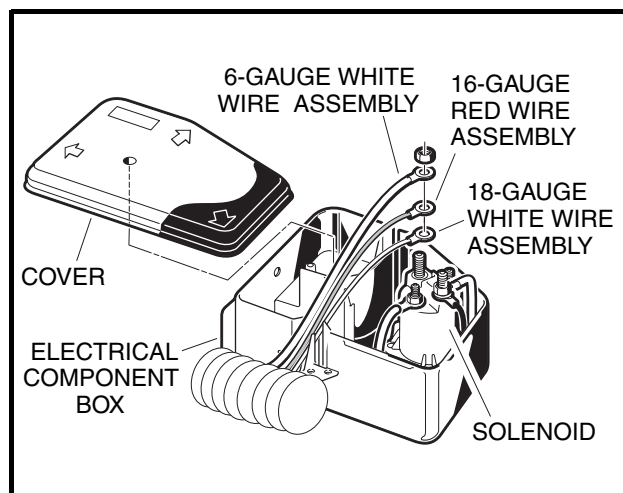

Figure 11-11 Remove Solenoid Wires

TEST PROCEDURE 6 – SOLENOID

See General Warning on page 1-1.

1. Turn the key switch OFF and remove the key. Place the Forward/Reverse handle in the NEUTRAL position. Chock the wheels.
2. Disconnect the battery cables as instructed. See **WARNING “To avoid unintentionally starting...”** in **General Warning on page 1-2**.
3. Remove the electrical component box cover.
4. Check that the wires are connected correctly and are tight. If they are not, rewire or tighten as necessary.
5. Set a multimeter to 200 ohms. Place the red (+) probe on one of the small posts of the solenoid and place the black (–) probe on the other small post. The reading should be 14 to 16 ohms. If the reading is not within limits, replace the solenoid.
6. Remove the wires from the large post of the solenoid. Do not allow the wires to touch the frame or other components of the vehicle (**Figure 11-11, Page 11-14**).
7. Set the multimeter to 200 ohms. Connect the red (+) probe to one of the large posts of the solenoid and connect the black (–) probe to the other large post (**Figure 11-12, Page 11-16**).
8. With the key switch in the OFF position, connect the battery, positive (+) cable first.
9. Place the Forward/Reverse handle in the NEUTRAL position. With the key in the OFF position, the reading on the multimeter should be no continuity. Turn the key switch to the START position and listen for the solenoid click. While holding the key in the START position, there should be continuity. After the key is released, it should rotate to the ON position and should be no continuity. If either reading is incorrect, replace the solenoid.
10. With the Forward/Reverse handle still in the NEUTRAL position, set the multimeter to 20 volts DC and place the red (+) probe on the large post that does *not* have wires connected to it. Place the black (–) probe on the vehicle frame. Turn key switch to the START position and listen for the solenoid click. While holding the key in the START position, the meter should read full battery voltage. If the reading is incorrect, replace the solenoid (**Figure 11-13, Page 11-16**).
11. Disconnect the 6-gauge black wire from the negative post of the battery before reconnecting the wires to the solenoid.
12. Reconnect the solenoid. See **Solenoid Installation, Section 13, Page 13-16**. See also following **WARNING**.

⚠ WARNING

- Incorrect wiring could result in severe injury or death.
- Diode and solenoid connections must have correct polarity.
- Keep all persons clear of engine belts when making final connections.

TEST PROCEDURE 7 – LOCKOUT CAM LIMIT SWITCH

See General Warning on page 1-1.

This limit switch is located on the Forward/Reverse switch assembly. A black wire and a green wire are connected to this limit switch.

1. Turn the key switch OFF and remove the key. Place the Forward/Reverse handle in the NEUTRAL position. Chock the wheels.

2. Disconnect the battery cables as instructed. See **WARNING “To avoid unintentionally starting...”** in **General Warning on page 1-2.**
3. Check for proper wiring and tight connections.

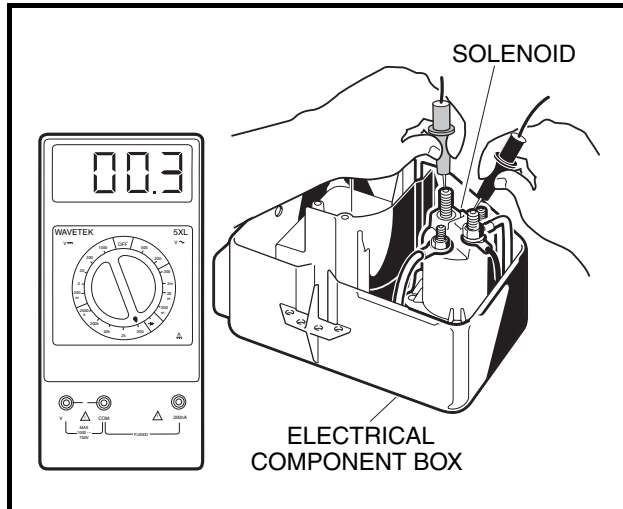

Figure 11-12 Test Solenoid Continuity

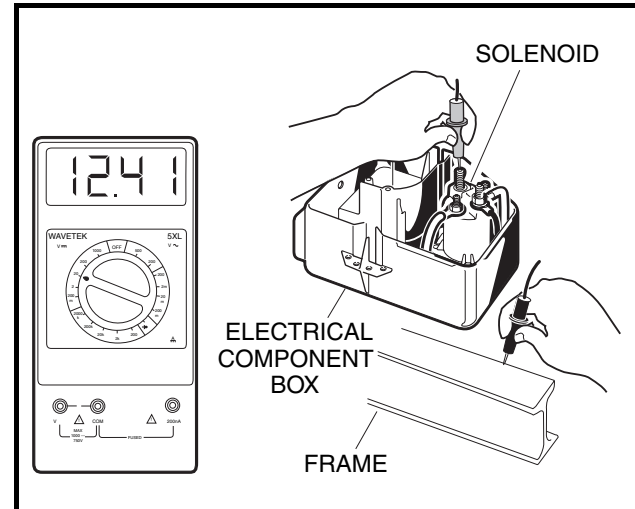

Figure 11-13 Test Solenoid Ground

4. Set the multimeter to 200 ohms. Place the red (+) probe of the multimeter on the common (COM) terminal of the limit switch. Place the black (–) probe on the normally open (NO) terminal of the switch. Without the lever pressed, the reading should be no continuity. Press the lever, and the reading should be continuity. If either reading is incorrect, replace the limit switch (**Figure 11-14, Page 11-16**).
5. Check to be sure the lobes on the cam are pressing the lockout cam limit switch when the Forward/Reverse shifter is in the NEUTRAL position only. The limit switch should make an audible click as it is pressed. If it does not, check for wear on the cam lobe. If the cam lobe will not activate the limit switch, replace the cam.

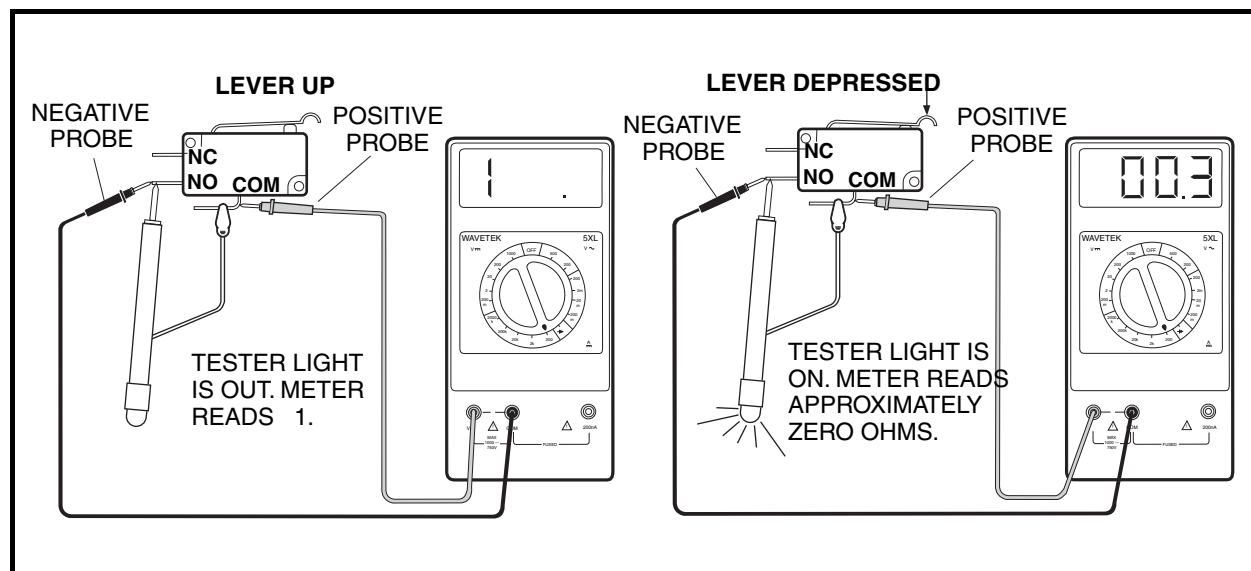

Figure 11-14 Test Lockout Cam Limit Switch

TEST PROCEDURE 8 – STARTER/GENERATOR (STARTER FUNCTION)

See General Warning on page 1-1.

1. Turn the key switch OFF and remove the key. Place the Forward/Reverse handle in the NEUTRAL position. Chock the wheels.
2. Disconnect the battery cables as instructed. **See WARNING “To avoid unintentionally starting...” in General Warning on page 1-2.**
3. Check that wires are connected correctly and are tight. If they are not, rewire or tighten as necessary.
4. Disconnect the wires from all the terminals on the starter/generator. Then place the black (–) probe of a multimeter, set to ohms, on the starter/generator housing (scratch through the finish to ensure a good ground). While holding the black probe against the housing, place the red (+) probe (one at a time) on the A1, A2, F1, F2 and DF terminals respectively (**Figure 11-15, Page 11-18**). The readings should be no continuity. If the readings are incorrect, the starter/generator will need to be removed from the vehicle and disassembled by a qualified technician. **See Starter/Generator Removal, Section 13, Page 13-1.**
 - An incorrect reading from the A1 or A2 terminal indicates three possible problems: 1) a grounded A1 or A2 terminal, 2) a grounded wire in the brush area, or 3) a grounded armature/commutator.
 - If the F1 or F2 reading is incorrect, it indicates a possible grounded F1 or F2 terminal or a grounded field coil.
 - If the DF reading is incorrect, it indicates a possible grounded DF terminal or a grounded field coil.
5. Disconnect the ground wire from the A2 terminal and the green wire from the A1 terminal on starter/generator.
6. Using a multimeter set to 200 ohms, place the red (+) probe on the A1 terminal and the black (–) probe on the A2 terminal. The reading should be continuity. If the reading is incorrect, a possible open or poor contact in a brush assembly and/or open armature windings may be the cause. The starter/generator will need to be removed from the vehicle and disassembled by a qualified technician. **See Starter/Generator Removal, Section 13, Page 13-1.**
7. With the wires still disconnected, using a multimeter set on 200 ohms, place the red (+) probe on the F1 terminal and the black (–) probe on the F2 terminal. The reading should be between approximately 0.1 and 0.3 ohms. If the reading is incorrect, a possible open field coil or bad connections at terminals may be the cause. The starter/generator will need to be removed from the vehicle and disassembled by a qualified technician. **See Starter/Generator Removal, Section 13, Page 13-1.**
8. With the wires still disconnected, using a multimeter set to 200 ohms, place the red (+) probe on the DF terminal and the black (–) probe on the F1 terminal. The reading should be between 4.5 and 5.5 ohms. If the reading is incorrect, a possible grounded DF terminal and/or grounded field coil may be the cause. The starter/generator will need to be removed from the vehicle and disassembled by a qualified technician. **See Starter/Generator Removal, Section 13, Page 13-1.**

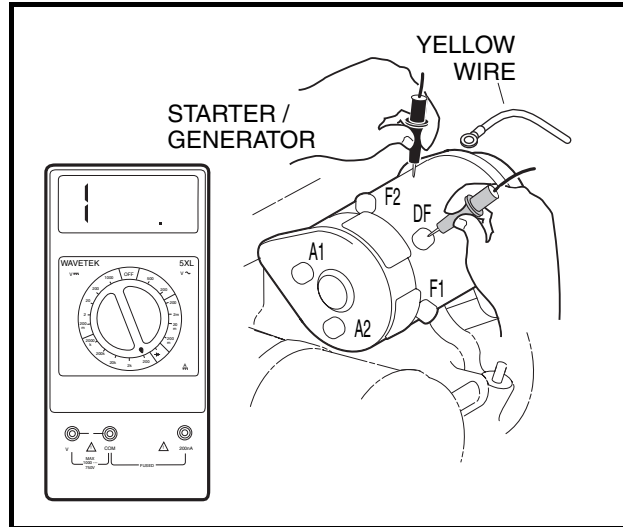

Figure 11-15 Check Starter Terminal Continuity

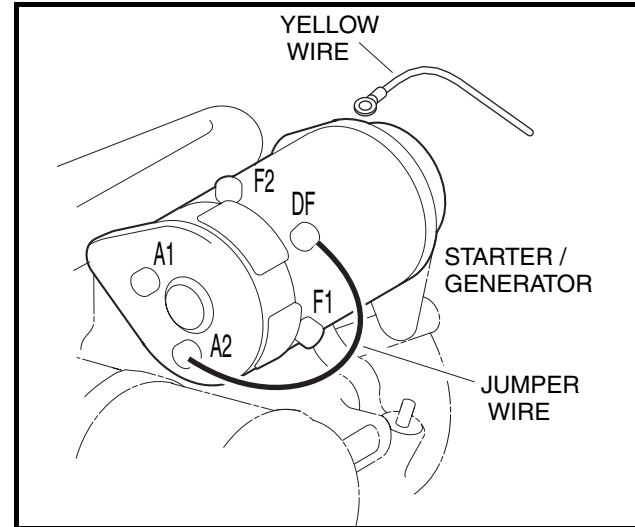

Figure 11-16 Jumper Wire Ground – DF to A2

TEST PROCEDURE 9 – WIRE CONTINUITY

See General Warning on page 1-1.

1. Turn the key switch OFF and remove the key. Place the Forward/Reverse handle in the NEUTRAL position. Chock the wheels.
2. Disconnect the battery cables as instructed. See **WARNING “To avoid unintentionally starting...”** in **General Warning on page 1-2.**
3. To test a wire for continuity, disconnect either end from the electrical component it is attached to.
4. Set the multimeter to 200 ohms and place the red (+) probe on the terminal at one end of the wire. Place the black (–) probe on the other terminal end of the wire. The reading should be continuity. If the reading is incorrect, repair or replace the wire.

TEST PROCEDURE 10 – DIODE (GENERATOR CIRCUIT)

See General Warning on page 1-1.

1. Turn the key switch OFF and remove the key. Place the Forward/Reverse handle in the NEUTRAL position. Chock the wheels.
2. Disconnect the battery cables as instructed. See **WARNING “To avoid unintentionally starting...”** in **General Warning on page 1-2.**
3. Disconnect the red and white wires of the diode assembly from the solenoid posts, located within the electrical component box.
 - 3.1. Remove the intake hose to the carburetor at the carburetor intake port and move the hose to allow easy access to the electrical component box cover.
 - 3.2. Remove the cover retaining screw (5) and electrical component box cover (6) (**Figure 11-17, Page 11-19**).
 - 3.3. Remove the locknuts (7) from the two large solenoid posts and disconnect the diode wires from the solenoid.

4. With the multimeter set to the diode test function ($\rightarrow \text{diode}$), connect the black (–) probe of the multimeter to the white lead of the diode and the red (+) probe of the multimeter to the red lead of the diode (**Figure 11-18, Page 11-20**). The reading should indicate an overload (no continuity). A diode is designed to conduct current in one direction only. If a diode conducts current (shows continuity) with the meter probes as described, the diode has failed and must be replaced. **See Diode Removal, Section 13, Page 13-12.**
5. Reverse the multimeter probes and note the reading. With the black (–) probe of the multimeter to the red lead of the diode and the red (+) probe of the multimeter to the white lead, the meter should read approximately 450 mV, however, a range of 400-500 mV is acceptable (**Figure 11-19, Page 11-20**).
6. Connect either the black (–) or red (+) lead of the multimeter to the diode body (case). Connect the other multimeter lead to both the red and white lead terminals of the diode. The multimeter should indicate an overload, (no continuity). If continuity reading does occur, it indicates that one or both of the diode leads are grounded to the diode body (case) and the diode must be replaced. **See Diode Removal, Section 13, Page 13-12.**
7. If the diode tests good, reconnect the diode leads. **See Diode Installation, Section 13, Page 13-12. See also following WARNING.**

▲ WARNING

- Incorrect wiring could result in severe injury or death.
- Diode and solenoid connections must have correct polarity.
- Keep all persons clear of engine belts when making final connections.

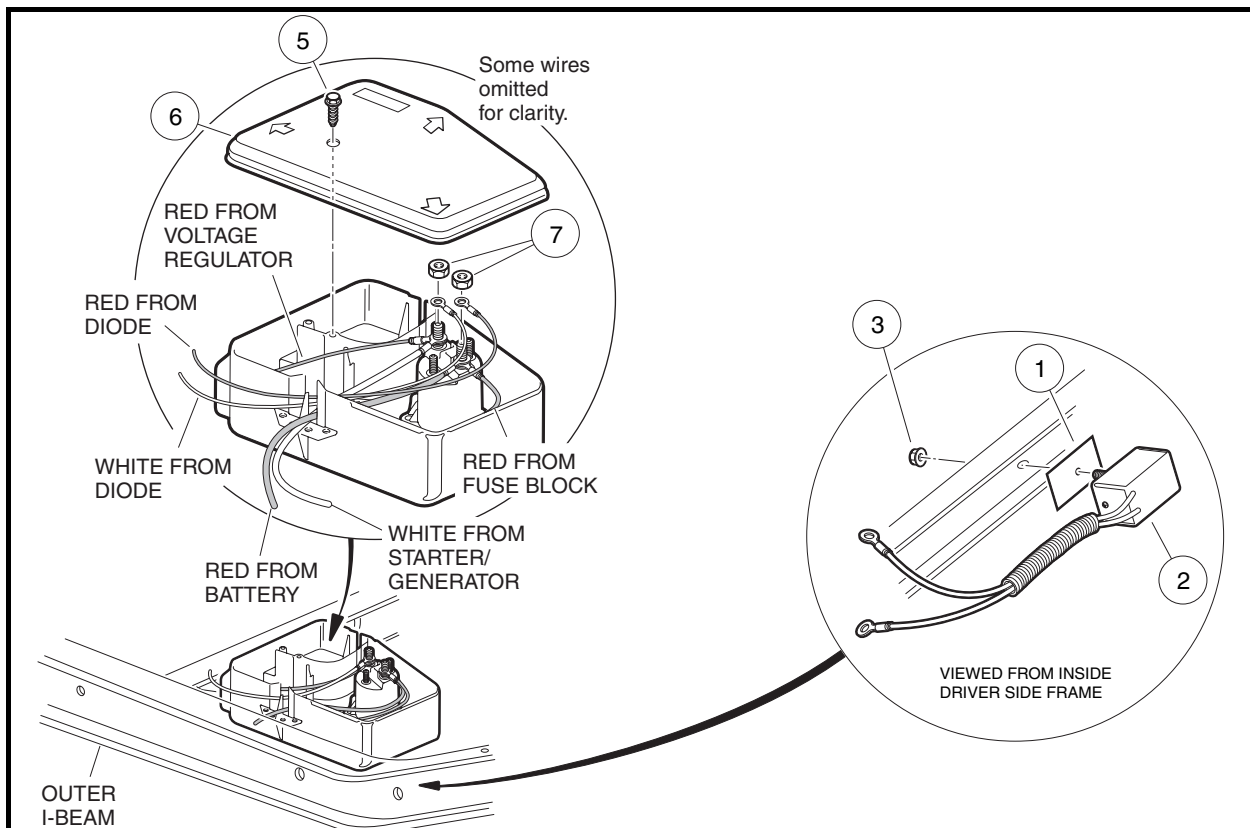

Figure 11-17 Electrical Control Box and Diode Orientation

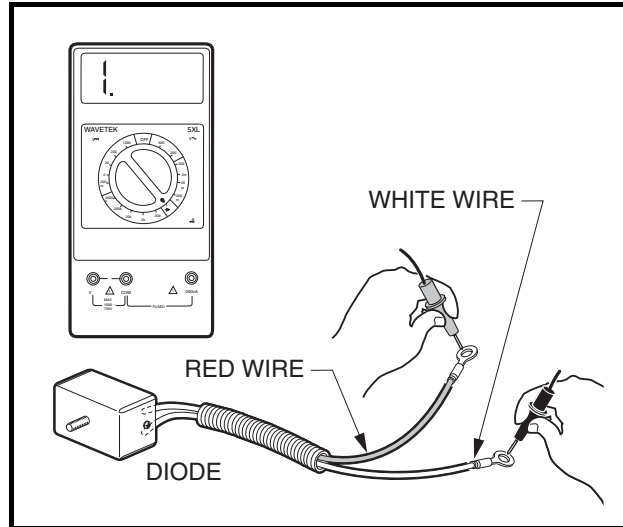

Figure 11-18 Diode Test

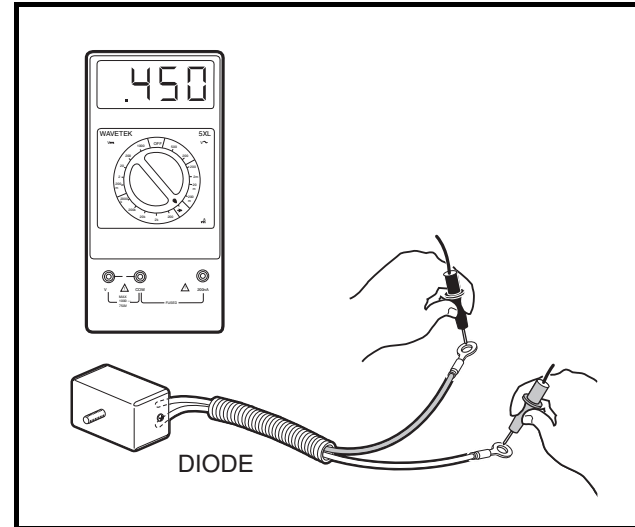

Figure 11-19 Diode Test – Probes Reversed

TEST PROCEDURE 11 – STARTER/GENERATOR (GENERATOR FUNCTION)

See General Warning on page 1-1.

NOTE: Perform Test Procedure 10 before proceeding with this test procedure.

Keep the battery connected while performing this test procedure.

1. Turn the key switch OFF and remove the key. Place the Forward/Reverse handle in the NEUTRAL position. Chock the wheels.
2. Ensure that the wires are connected correctly and are tight. If they are not, rewire or tighten as necessary.
3. Disconnect the yellow wire from the DF terminal on the starter/generator. Cover the connector on the yellow wire to make sure the yellow wire will not short to ground. Then, using a jumper wire, ground the DF terminal to the A2 terminal (**Figure 11-16, Page 11-18**).
4. Using a multimeter set to 20 volts DC, place the red (+) probe on the positive (+) cable of the battery, and place the black (–) probe on the negative (–) post. Start the engine and run it at full governed speed. The reading should show the voltage rising on the meter. If the voltage rises, see Test Procedure 12 – Voltage Regulator on page 11-20. If the voltage does not rise, and the diode was found to be functioning properly in Test Procedure 10, a tear-down inspection of the starter/generator will be necessary. **See Starter/Generator Removal, Section 13, Page 13-1.**
5. Reconnect the yellow wire to the DF terminal on the starter/generator.

TEST PROCEDURE 12 – VOLTAGE REGULATOR

See General Warning on page 1-1.

NOTE: Perform Test Procedures 10 and 11 before proceeding with this test procedure.

Keep the battery connected while performing this test procedure.

1. Turn the key switch OFF and remove the key. Place the Forward/Reverse handle in the NEUTRAL position. Chock the wheels.
2. Check that the wires are connected correctly and are tight. If they are not, rewire or tighten as necessary.

3. Check the engine RPM setting to ensure that it is adjusted correctly. **See Engine RPM Adjustment on page 16-12.**
4. With the battery in good condition and fully charged, run the engine for several minutes to bring the voltage regulator to operating temperature.
5. Turn the key switch to the OFF position, killing the engine. Using a multimeter set to 20 volts DC, place the red (+) probe on the large post of the solenoid with the red wire from the voltage regulator attached. Place the black (-) probe on the negative (-) battery post (**Figure 11-20, Page 11-21**). With the Forward/Reverse handle in the NEUTRAL position and the wheels chocked, turn the key switch to the START position to start the engine. Press the accelerator to run the engine at full governed speed. If the reading is between 14.7 and 15.3 volts, the regulator is good. If the reading is lower than 14.7 volts but rising steadily, check battery condition. **See Hydrometer Test on page 11-9.** If the reading is lower than 14.7 volts and not rising, and the starter/generator is good; or if the reading is over 15.3 volts and continues to rise, replace voltage regulator. **See Voltage Regulator Removal, Section 13, Page 13-11.**

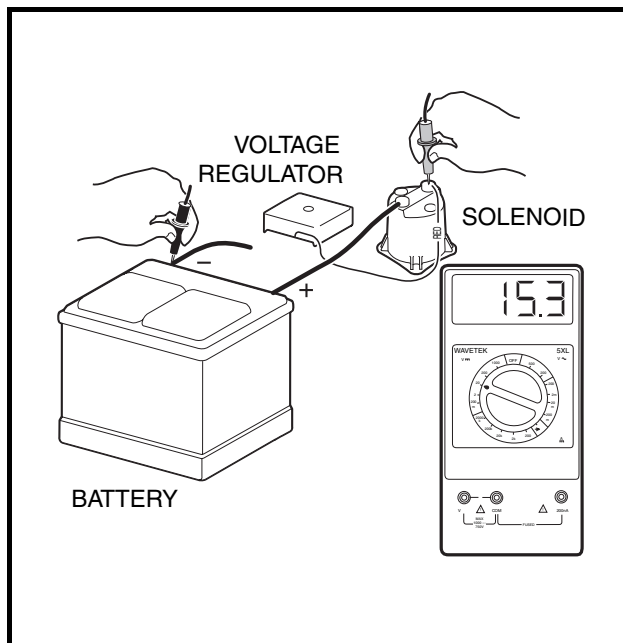

Figure 11-20 Test Voltage Regulator

TEST PROCEDURE 13 – GROUNDED KILL WIRE

See General Warning on page 1-1.

NOTE: Keep the battery connected while performing this test procedure.

1. Turn the key switch OFF and remove the key. Place the Forward/Reverse handle in the NEUTRAL position. Chock the wheels.
2. Disconnect the engine-kill white/black wire at the bullet connector located next to the RPM limiter (**Figure 11-22, Page 11-22**).

NOTE: Disconnecting the engine-kill wire removes it from the start/stop circuit.

3. Turn the key switch to the START position and release after the engine starts. If the engine starts and continues to idle, check the kill-wire for grounding, the kill limit switch, and the key switch. **See Test Procedure 18 – Engine Kill Wire on page 11-29. See following WARNING.**

⚠ WARNING

- **When the white/black engine kill wire is disconnected, the engine will not stop running after the key switch is turned to the OFF position. It will be necessary to pull and hold the choke handle until the engine stops running.**
4. If the engine does not run, connect the white/black wire at the bullet connector next to the RPM limiter and proceed to Test Procedure 14 – Ignition Spark on page 11-22.

TEST PROCEDURE 14 – IGNITION SPARK

See General Warning on page 1-1.

NOTE: Keep the battery connected while performing this test procedure.

1. Turn the key switch OFF and remove the key. Place the Forward/Reverse handle in the NEUTRAL position. Chock the wheels.
2. Remove the plug wire from the spark plug. Using an ignition spark gap test tool (Thexton 404[®] or equivalent), check for correct spark (**Figure 11-21, Page 11-22**).
 - 2.1. Adjust the tester probes to approximately to 18,000 volts (18 Kv) setting (SE – *Small Engine Setting* on the Thexton 404 tool). Connect the tester to the spark plug wire, and connect the alligator clip to a solid engine ground.
 - 2.2. Start the engine. There should be a strong blue spark between the probes of the spark gap tester. If there is no spark, or if the spark is a faint yellow or red color, test components of the ignition circuit.
3. If the spark gap tester tool indicates a strong blue spark, it is possible the spark plug has failed internally. Check the spark plug gap. The gap should be set at 0.027 to 0.031 of an inch (0.69 to 0.79 mm). If the gap is correct, replace the spark plug with a new part and test the engine for proper operation.

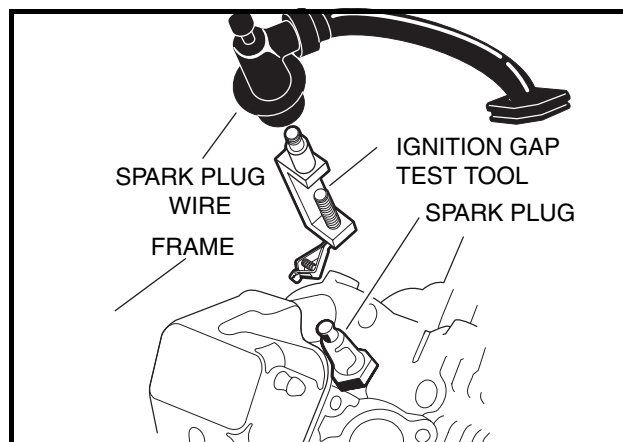

Figure 11-21 Ignition Spark Test

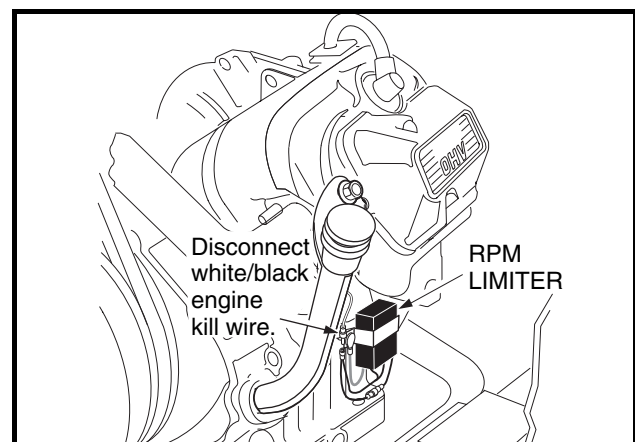

Figure 11-22 Disconnect White/Black Engine Kill Wire

TEST PROCEDURE 15 – RPM LIMITER

See General Warning on page 1-1.

1. Turn the key switch OFF and remove the key. Place the Forward/Reverse handle in the NEUTRAL position. Chock the wheels.
2. Disconnect the battery cables as instructed. See **WARNING “To avoid unintentionally starting...”** in General Warning on page 1-2.
3. Disconnect both of the bullet terminals (**Figure 11-23, Page 11-23**).
4. Using a multimeter set to 200 ohms, place the red (+) probe on the brown ground wire and place the black (–) probe on one of the black wire female bullet connectors. The reading should be no continuity. If the reading is not correct, replace the RPM limiter.
5. This test will find most bad RPM limiters. Some of them may bench test okay but fail under a load due to heat while operating. Another method of testing is to replace the RPM limiter and then run the engine. If the engine runs properly, keep the new RPM limiter in the circuit.

TEST PROCEDURE 16 – IGNITION COIL

See General Warning on page 1-1.

The following test procedures will properly detect a coil that has failed in most cases; however, in rare cases, some ignition coils can fail to operate at normal (warmer) operating temperatures. If the ignition coil has tested okay in the vehicle and on the bench, but fails to operate reliably, replace the coil with a known good coil and operate the engine for several minutes to ensure that the coil functions at normal operating temperature. If the new coil functions properly, keep the new coil in the circuit.

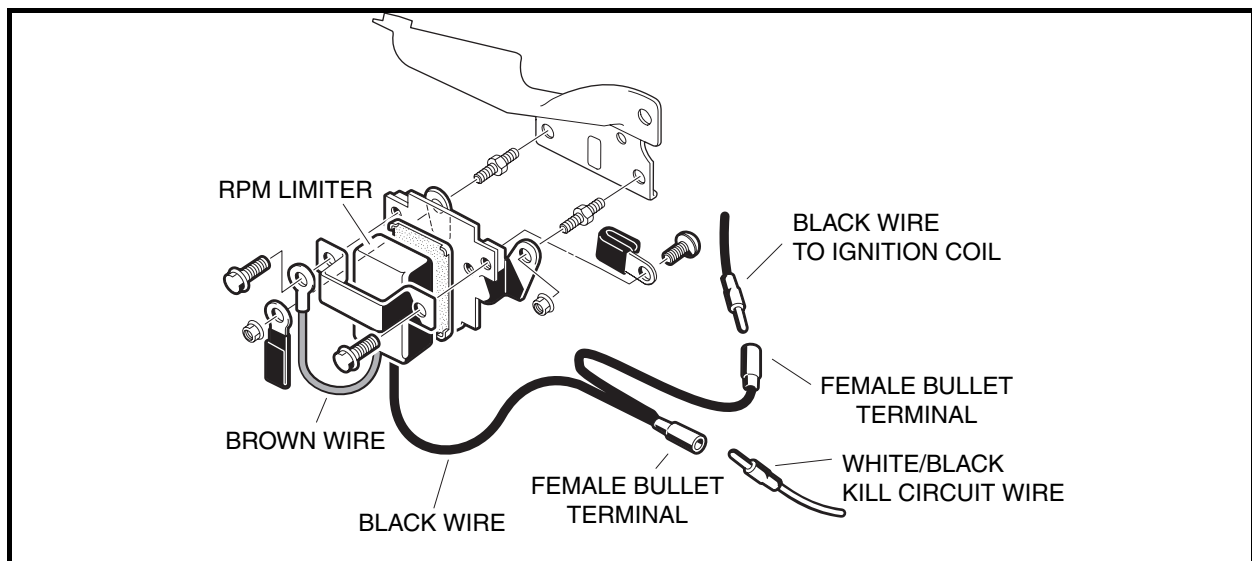

Figure 11-23 RPM Limiter

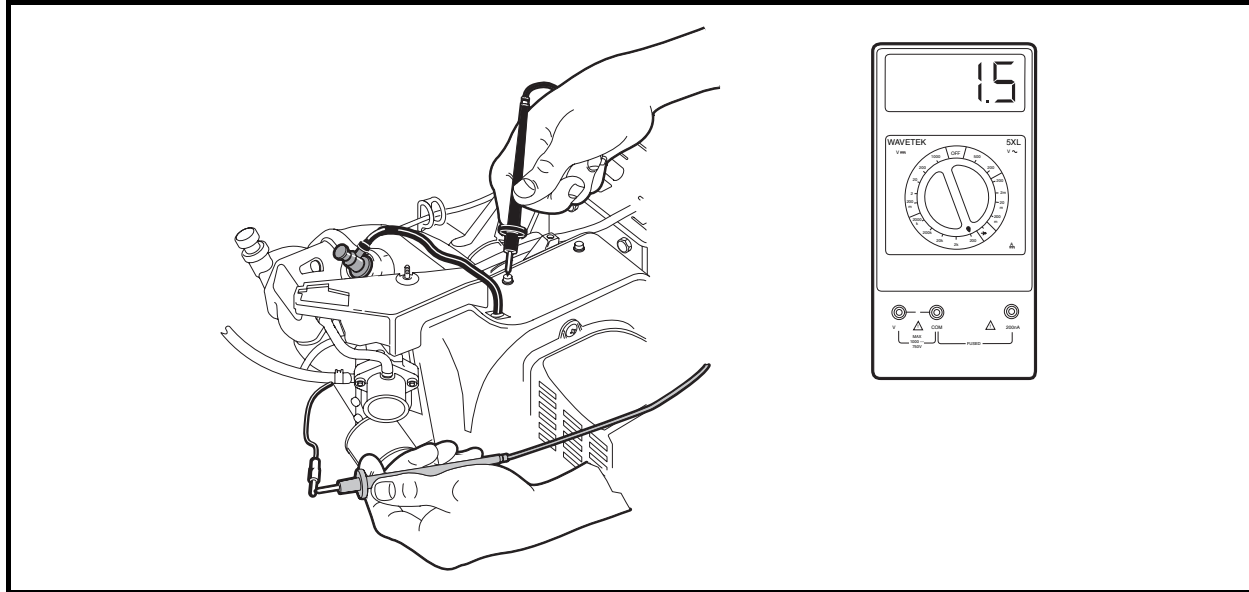

Figure 11-24 Primary Coil Resistance – In Vehicle Test

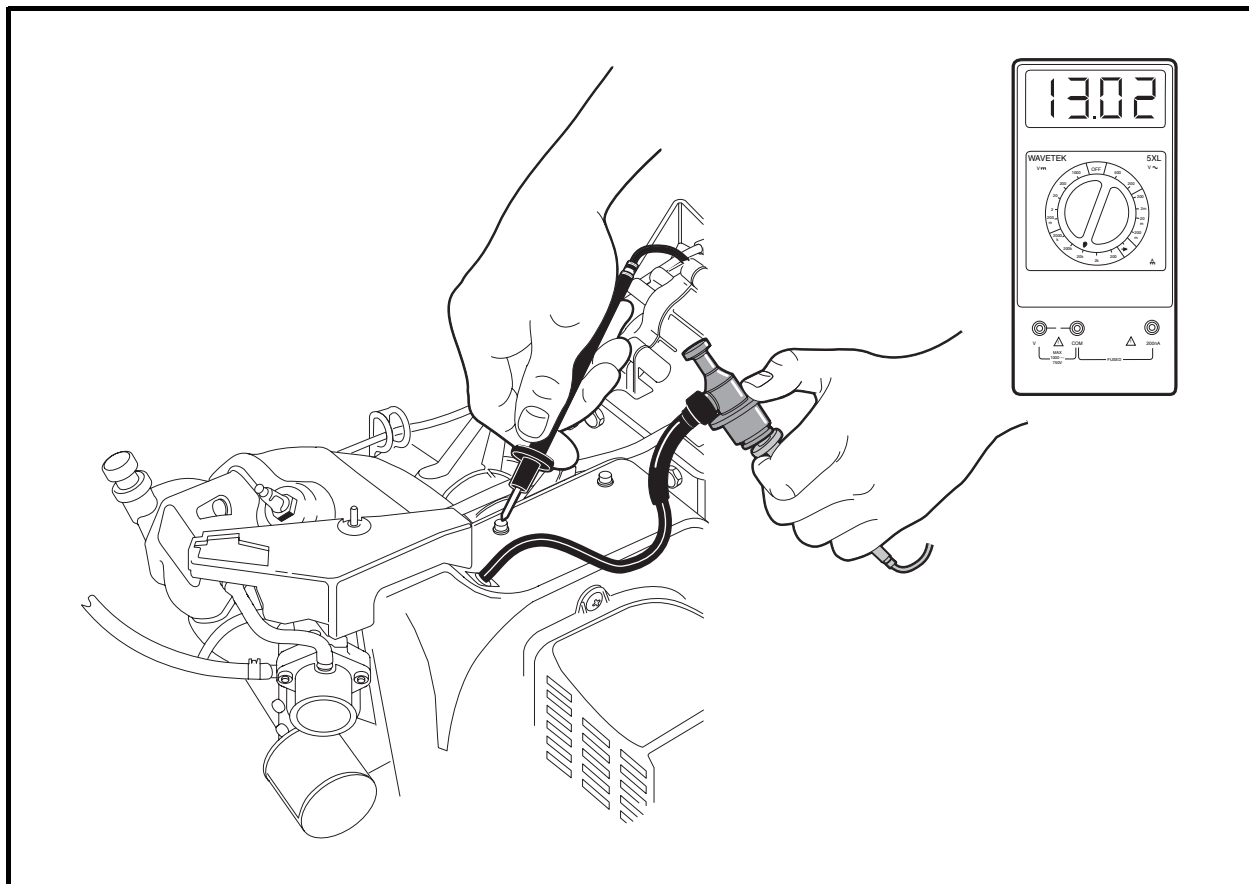

Figure 11-25 Secondary Coil Test – In Vehicle Test

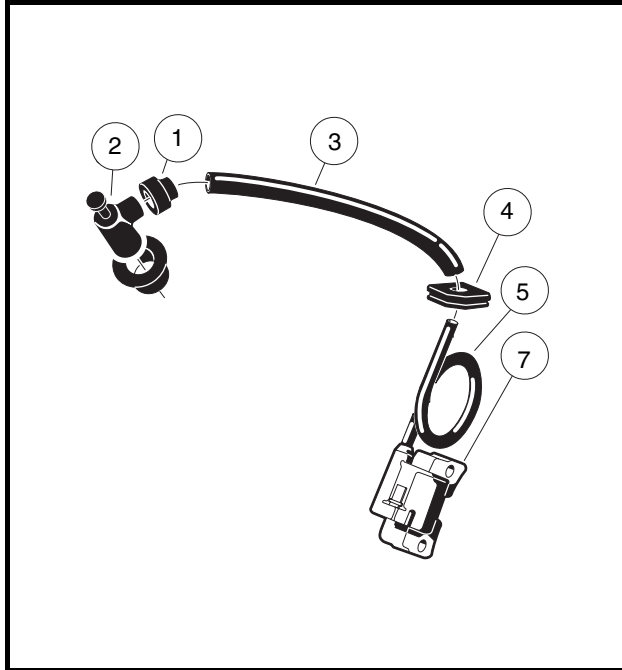

Figure 11-26 Ignition Coil and Cap

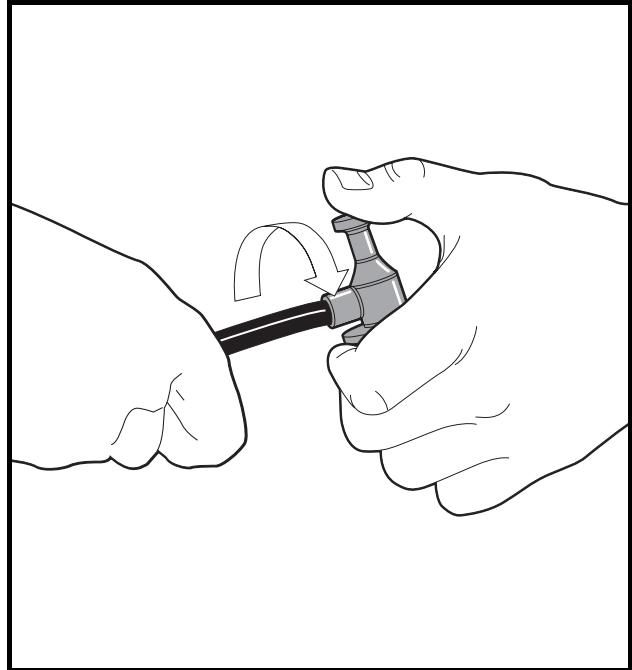

Figure 11-27 Spark Plug Cap Removal

Ignition Coil – In Vehicle Test

1. Turn the key switch OFF and remove the key. Place the Forward/Reverse handle in the NEUTRAL position. Chock the wheels.
2. Disconnect the battery cables as instructed. **See WARNING “To avoid unintentionally starting...” in General Warning on page 1-2.**
3. Using a multimeter set to 200 ohms, measure the primary coil resistance.
 - 3.1. Disconnect both of the bullet terminals at the RPM limiter (**Figure 11-23, Page 11-23**). Place the red (+) probe of the meter on the male bullet terminal of the wire connecting to the ignition coil under the fan housing, and place the black (-) probe on a clean unpainted surface of the engine or frame (**Figure 11-24, Page 11-24**).
 - 3.2. If the resistance is not between 0.6 - 1.7 ohms, bench test the ignition coil. **See Ignition Coil – Bench Test on page 11-26.**
4. Using a multimeter set to 20k ohms, measure the resistance of the secondary coil and spark plug cap together.
 - 4.1. Place the red (+) probe of the meter into the end of the spark plug cap that normally connects to the spark plug and place the black (-) probe on a clean unpainted surface of the engine or frame (**Figure 11-25, Page 11-24**).
 - 4.2. If the resistance is between 12.0k - 14.0k ohms, the secondary coil and spark plug cap are within acceptable limits; proceed to step 7 on page 11-26. If the resistance is not between 12.0k - 14.0k ohms, the spark plug cap and secondary coil must be tested independently from each other.
5. Test the spark plug cap separately from the secondary coil.
 - 5.1. Remove the rubber gasket (1) on the plug cap (2) by rolling back the gasket onto the spark plug wire (3) (**Figure 11-26, Page 11-25**).
 - 5.2. Remove the cap from the wire by turning the cap counterclockwise three or four revolutions while gently pulling it off the wire (**Figure 11-27, Page 11-25**).
 - 5.3. Using a multimeter set to 20k ohms, place the red (+) probe of the multimeter into the end of the

spark plug cap that normally connects to the spark plug and place the black (–) probe into the end of the cap with the internal screw (**Figure 11-28, Page 11-26**). If the resistance is not between 4.5k - 6.0k ohms, the cap has failed and must be replaced. Proceed to the next step with the spark plug cap still removed.

6. Test the secondary coil separately from the spark plug cap.
 - 6.1. Using a multimeter set to 20k ohms, place the red (+) probe of the meter into the end of the spark plug wire and place the black (–) probe on a clean unpainted surface of the engine or frame (**Figure 11-29, Page 11-27**). If the resistance is between 6.0k - 11.0k ohms, the secondary coil is within acceptable limits. If the resistance is not between 6.0k - 11.0k ohms, bench test the ignition coil.
7. If the preceding procedures indicate that the ignition coil resistance readings are within acceptable ranges, but the coil fails to function properly, proceed to the following bench test procedures.

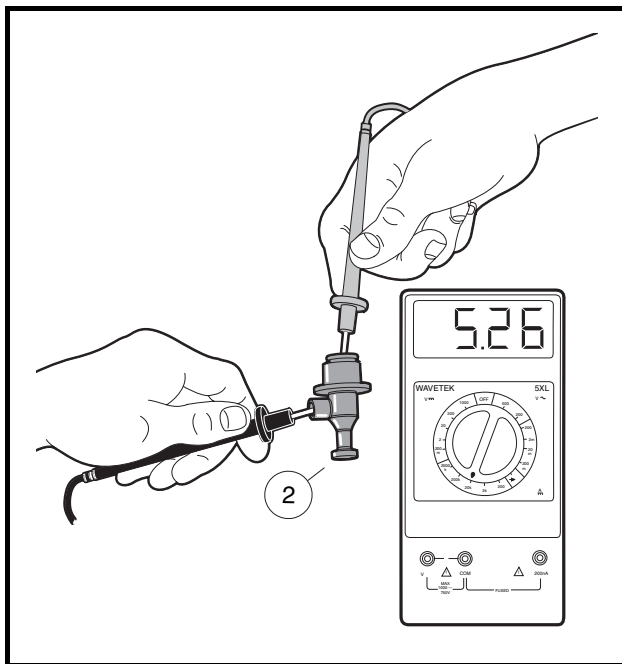

Figure 11-28 Spark Plug Cap Test

Ignition Coil – Bench Test

1. Remove the coil from the engine. **See Ignition Coil Removal, Section 13, Page 13-24.**
2. Using a multimeter set to 200 ohms, measure the primary coil resistance.
 - 2.1. Place the black (–) probe of the meter on the terminal on the ignition coil (1), and place the red (+) probe on the core (2) (**Figure 11-30, Page 11-27**).
 - 2.2. If the resistance is not between 0.6 - 1.7 ohms, replace the ignition coil.
3. Using a multimeter set to 20k ohms, measure the resistance of the secondary coil and spark plug cap together.
 - 3.1. Place the red (+) probe of the meter into the end of the spark plug cap that normally connects to the spark plug (3) and place the black (–) probe on the core (2) (**Figure 11-31, Page 11-27**).
 - 3.2. If the resistance is between 12.0k - 14.0k ohms, the secondary coil and spark plug cap are within acceptable limits; proceed to step 6 on page 11-28. If the resistance is not between 12.0k - 14.0k ohms, the spark plug cap and secondary coil must be tested independently from each other.

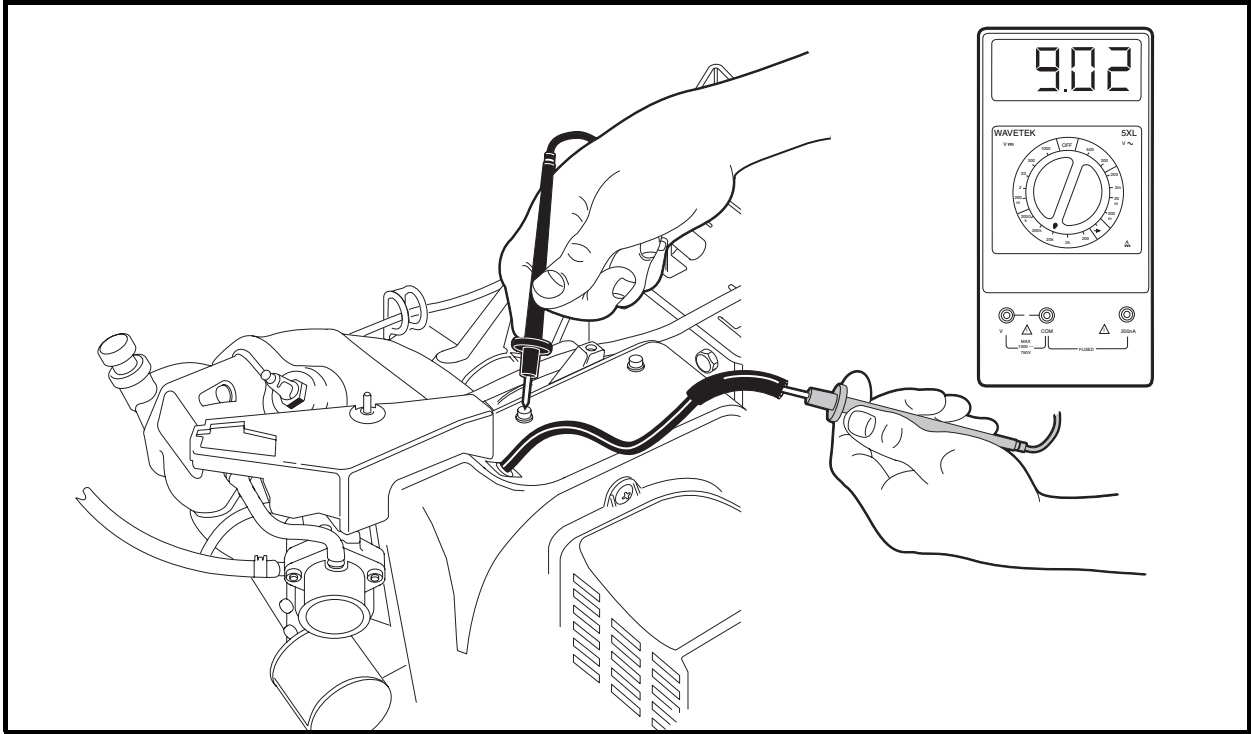

Figure 11-29 Secondary Coil Test Without Cap

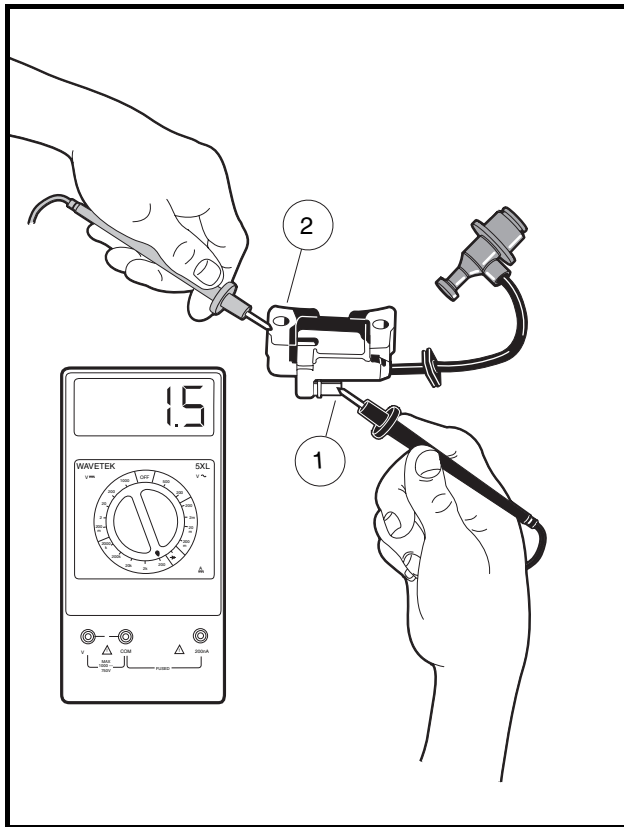

Figure 11-30 Primary Coil Resistance - Bench Test

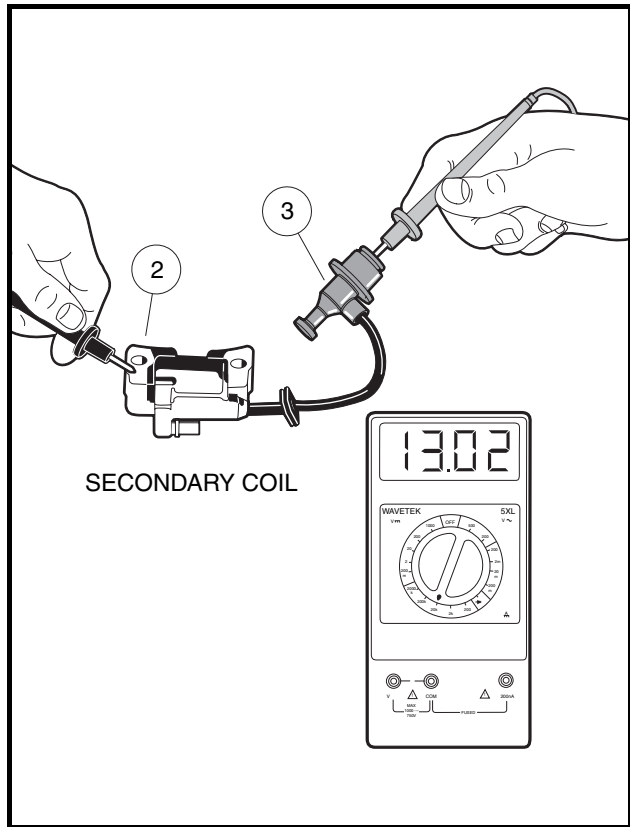

Figure 11-31 Secondary Coil and Cap Resistance - Bench Test

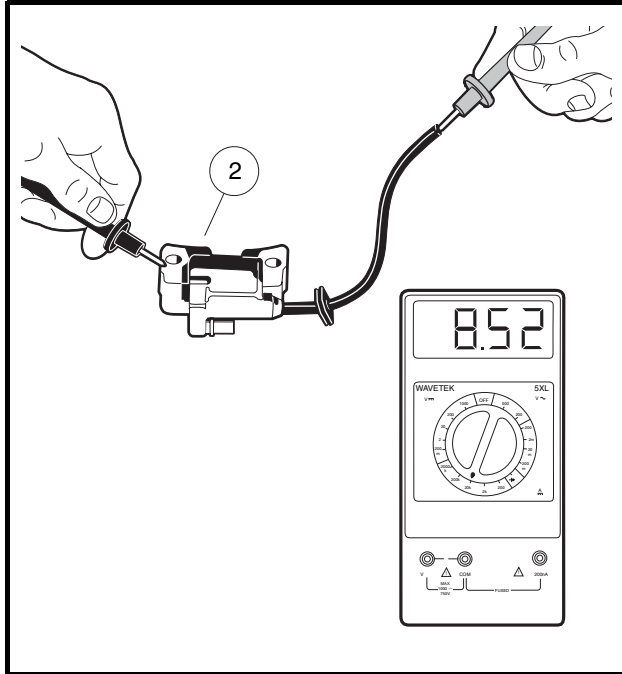

Figure 11-32 Secondary Coil Resistance – Bench Test

4. If not previously tested, test the spark plug cap separately from the secondary coil.
 - 4.1. Remove the rubber gasket (1) on the plug cap (2) by rolling back the gasket onto the spark plug wire (3) (**Figure 11-26, Page 11-25**).
 - 4.2. Remove the cap from the wire by turning the cap counterclockwise three or four revolutions while gently pulling it off the wire (**Figure 11-27, Page 11-25**).
 - 4.3. Using a multimeter set to 20k ohms, place the red (+) probe of the multimeter into the end of the spark plug cap that normally connects to the spark plug and place the black (–) probe into the end of the cap with the internal screw (**Figure 11-28, Page 11-26**). If the resistance is not between 4.5k - 6.0k ohms, the cap has failed and must be replaced. Proceed to the next step with the spark plug cap still removed.
5. Test the secondary coil separately from the spark plug cap.
 - 5.1. Using a multimeter set to 20k ohms, place the red (+) probe of the meter into the end of the spark plug wire and place the black (–) probe on the core (2) (**Figure 11-32, Page 11-28**). If the resistance is between 6.0k - 11.0k ohms, the secondary coil is within acceptable limits. If the resistance is not between 6.0k - 11.0k ohms, the ignition coil has failed and must be replaced.
6. If the preceding procedures indicate that the ignition coil resistance readings are within acceptable ranges, but the coil fails to function properly, replace the ignition coil and cap.

TEST PROCEDURE 17 – KEY SWITCH (ENGINE KILL CIRCUIT)

See General Warning on page 1-1.

1. Turn the key switch OFF and remove the key. Place the Forward/Reverse handle in the NEUTRAL position. Chock the wheels.
2. Disconnect the battery cables as instructed. **See WARNING “To avoid unintentionally starting...” in General Warning on page 1-2.**
3. Remove the instrument panel. **See Key Switch Removal, Section 13, Page 13-14.**

4. Remove the connector from the key switch.
5. Place the red (+) probe on the (M) terminal and the black (-) probe on the (G) terminal. With the key switch OFF, the reading should be continuity. With the key switch turned ON, the reading should be no continuity. If either reading is incorrect, replace the key switch (**Figure 11-33, Page 11-29**).
6. Reconnect the key switch to the wire harness. Ensure that the connector is connected correctly and is tight. If it is not, repair or replace as necessary.

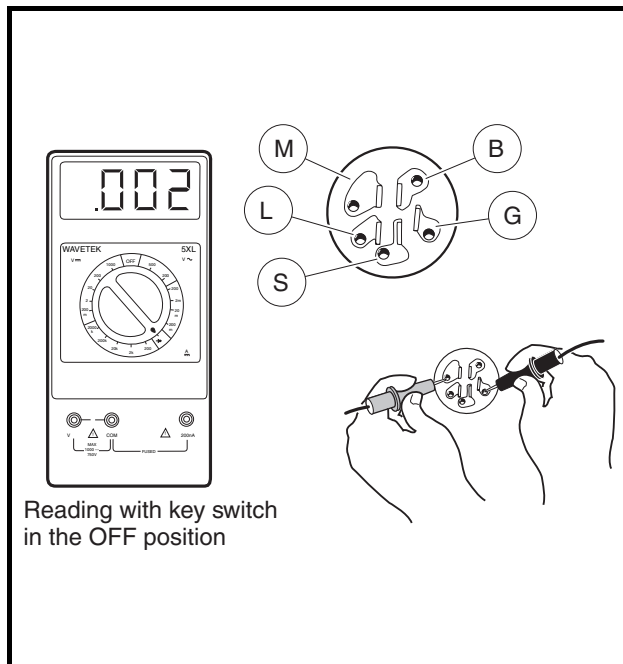

Figure 11-33 Test Key Switch – Engine Kill Circuit

TEST PROCEDURE 18 – ENGINE KILL WIRE

See **General Warning** on page 1-1.

1. Turn the key switch OFF and remove the key. Place the Forward/Reverse handle in the NEUTRAL position. Chock the wheels.
2. Disconnect the battery cables as instructed. See **WARNING “To avoid unintentionally starting...”** in **General Warning** on page 1-2.
3. Disconnect white/black wire bullet connector located at the engine RPM limiter (**Figure 11-22, Page 11-22**).
4. Connect red (+) probe of multimeter to the male bullet terminal on the white/black wire and connect the black (-) probe to the vehicle frame.
5. With the Forward/Reverse handle in the NEUTRAL position, turn the key switch to the ON position and note the multimeter reading. Turn the key and hold it in the START position while noting the multimeter reading. There should be no continuity when the key switch is in the ON or START position. If there is continuity, check for worn insulation on the white/black wire that is allowing the wire to ground to the frame.

TEST PROCEDURE 19 – REVERSE BUZZER LIMIT SWITCH

See General Warning on page 1-1.

NOTE: Keep the battery connected while performing this test procedure.

The reverse buzzer limit switch is located on the Forward/Reverse shifter; red/white and orange wires are connected to it.

1. Turn the key switch OFF and remove the key. Place the Forward/Reverse handle in the NEUTRAL position. Chock the wheels.
2. Move the Forward/Reverse handle to REVERSE and listen for an audible click from the limit switch. If there is no click, check the switch for proper alignment and switch arm movement.
3. If the switch is being activated but the buzzer does not function, place the red (+) probe of the multimeter on one terminal and the black (–) probe on the other terminal of the limit switch. Without the lever pressed, the reading should be no continuity. Press the lever and the reading should be continuity. If either reading is incorrect, replace limit switch.

TEST PROCEDURE 20 – REVERSE BUZZER

See General Warning on page 1-1.

The front reverse buzzer is mounted to the instrument panel under the front body.

1. Turn the key switch OFF and remove the key. Place the Forward/Reverse handle in the NEUTRAL position. Chock the wheels.
2. Disconnect the battery cables as instructed. See **WARNING “To avoid unintentionally starting...”** in **General Warning on page 1-2.**
3. Remove the instrument panel. See **Key Switch Removal, Section 13, Page 13-14.**
4. Check for proper wiring and tight connections. Using a multimeter, individually check for continuity through each wire that connects to the reverse buzzer. If the buzzer will not function when properly wired, replace the buzzer. See **Reverse Warning Buzzer, Section 13, Page 13-19.**

TEST PROCEDURE 21 – OIL LEVEL SENSOR

See General Warning on page 1-1.

NOTE: Keep the battery connected while performing this test procedure.

1. Turn the key switch OFF and remove the key. Place the Forward/Reverse handle in the NEUTRAL position. Chock the wheels.
2. Disconnect the spark plug wire. See **WARNING “To avoid unintentionally starting...”** in **General Warning on page 1-2.**
3. Ensure that the low oil warning light and all connecting wires are functioning correctly. See **Test Procedure 22 – Oil Warning Light on page 11-31.**
4. Drain the engine oil into an approved container and properly dispose of used oil.
5. Turn the key switch ON, closing the circuit. The oil light should illuminate. If the low oil warning light does not illuminate, the oil level sensor may need to be replaced. Refer to Test Procedure 22 before replacing sensor. See **Oil Level Sensor Removal, Section 15, Page 15-5.**
6. Fill the engine with new oil and install a new oil filter before returning the vehicle to service. See **Engine Oil – Gasoline Vehicles, Section 10, Page 10-6.**

TEST PROCEDURE 22 – OIL WARNING LIGHT

See General Warning on page 1-1.

1. Turn the key switch OFF and remove the key. Place the Forward/Reverse handle in the NEUTRAL position. Chock the wheels.
2. Disconnect the battery cables as instructed. See **WARNING “To avoid unintentionally starting...”** in **General Warning on page 1-2.**
3. Remove the instrument panel. See **Key Switch Removal, Section 13, Page 13-14.**
4. Ensure that the wires are connected correctly and are tight. If they are not, rewire or tighten as necessary.
5. Disconnect the yellow wire (to the oil level sensor) from the terminal on the oil light. Using an alligator clip jumper wire, connect the oil light terminal to the vehicle frame. Connect the red (+) battery cable to the positive (+) battery post, then attach the black (–) cable to the negative (–) battery post.
6. Turn the key switch to the ON position. The oil light should illuminate. If it does not, check continuity of the yellow wire that connects the key switch to the oil light through a sonic weld connection within the wire harness. If there is no continuity in the wire, replace the wire. Then test the key switch. See **Test Procedure 4 – Key Switch (Starter Circuit) on page 11-13.** If the yellow wire and the key switch test okay, then replace the oil light.

TEST PROCEDURE 23 – LOCKOUT CAM

See General Warning on page 1-1.

Check to be sure the lobes on the cam are pressing the lockout cam limit switch when the Forward/Reverse shifter is in the NEUTRAL position only. The limit switch should make an audible click as it is pressed. If it does not, check for wear on the cam lobe. If the cam lobe will not activate the limit switch, replace the cam.

TEST PROCEDURE 24 – BATTERY TEST (UNDER LOAD)

See General Warning on page 1-1.

NOTE: Keep the battery connected while performing this test procedure.

1. Turn the key switch OFF and remove the key. Place the Forward/Reverse handle in the NEUTRAL position. Chock the wheels.
2. Set a multimeter to 20 volts and place the red (+) probe on the F2 (white wire) terminal on the starter/generator. Place the black (–) probe on the negative battery post.
3. Turn the key switch to the START position and hold it in the START position while noting the voltage reading on the multimeter (with the key in the START position the battery is under load).
 - 3.1. If the voltage reading is over 9.6 volts at 70 °F (21 °C) (electrolyte temperature) check the starter/generator. See following **NOTE.**

NOTE: The voltage reading is taken at 70 °F (21 °C). At lower electrolyte temperatures the voltage reading will be lower.

- 3.2. If the reading is below 9.6 volts at 70 °F (21 °C) (electrolyte temperature), check the battery. See **Test Procedure 1 – Battery on page 11-9.**
 - 3.3. If the reading is zero, there may be NO continuity across the large posts of the solenoid. See **Test Procedure 6 – Solenoid on page 11-15.**
4. If all of the test results are good and the voltage reading is zero, there may be a broken or damaged 6-gauge white wire from the solenoid to the starter/generator. See **Test Procedure 8 – Starter/Generator (Starter Function) on page 11-17.**

TEST PROCEDURE 25 – FUEL LEVEL SENDING UNIT

See **General Warning** on page 1-1.

 WARNING

- **To avoid the possibility of fire or explosion, make sure the fuel tank cap is securely in place while performing this test procedure.**
1. Turn the key switch to OFF and remove the key. Place the Forward/Reverse handle in the NEUTRAL position. Chock the wheels.
 2. Disconnect the battery cables as instructed. **See WARNING “To avoid unintentionally starting...” in General Warning on page 1-2.**
 3. Disconnect the orange wire from the center post of the fuel level sending unit.
 4. With a multimeter set to 2k ohms, place the red (+) probe of the multimeter on the center post of the sending unit. Place the black (–) probe on the ground connection of the sending unit (**Figure 11-34, Page 11-33**).
 5. The following resistance readings (in ohms) should be obtained depending on the position of the float inside the fuel tank. The resistance reading will vary according to the exact position of the float. The chart below may be used as a guideline to determine if the fuel level sending unit is operating correctly. Make sure the float is at the surface of the fuel in the tank.

FLOAT POSITION	RESISTANCE READING	FUEL GAUGE READINGS
Lower position (tank empty)	240 ± 20 ohms	Empty
Center position (tank half full)	120 ± 20 ohms	Half full
Upper position (tank full)	60 ± 20 ohms	Full

6. If the readings are within the specifications listed above, the fuel level sending unit is working properly. If the readings are incorrect, the fuel level sending unit has failed and the fuel tank must be replaced. **See Fuel Tank Removal on page 16-22.**
7. If the readings are correct and the fuel gauge does not function correctly, check the continuity of the orange wire from the fuel level sending unit to the fuel gauge/hour meter. Leave the battery disconnected while checking continuity. Also check the continuity of the yellow wire from the fuel gauge/hour meter to the key switch, and the black ground wires at the fuel level sending unit and at the fuel gauge/hour meter. **See Fuel Gauge/Hour Meter Removal, Section 13, Page 13-22.**
8. If the readings are correct according to the position of the float, but give an incorrect reading on the fuel gauge/hour meter, test the fuel gauge/hour meter. **See Test Procedure 26 – Fuel Gauge on page 11-33.**

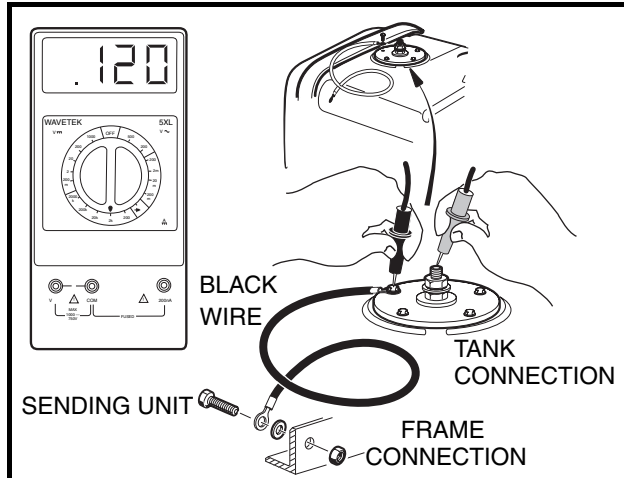

Figure 11-34 Test Fuel Level Sending Unit

TEST PROCEDURE 26 – FUEL GAUGE

See General Warning on page 1-1.

Two fuel gauges were used for model year 2007 (Figure 11-35, Page 11-33 and Figure 11-36, Page 11-33). The terminal configuration on the back of the gauge easily denotes the type. Follow the appropriate procedure. The gauge used through mid-2007 has the orange wire connected to terminal 1 whereas the gauge used from mid-2007 has it connected to terminal 4 in the center of the gauge. In addition, the gauge used through mid-2007 has one terminal (3) to ground it whereas the gauge used from mid-2007 has two ground terminals (1 and 6) with a black jumper wire connecting them. **See following NOTE.**

NOTE: Keep the battery connected during this test procedure.

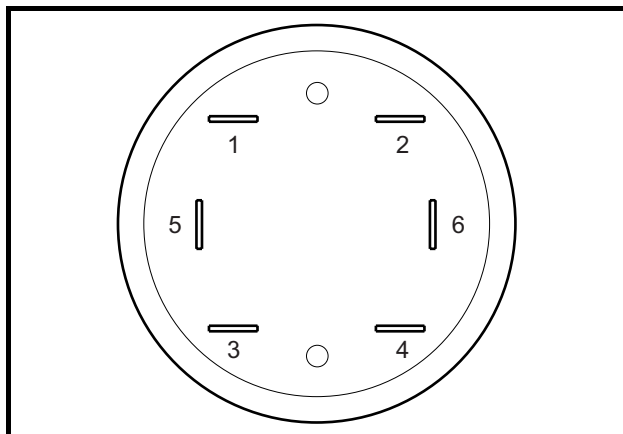

Figure 11-35 Fuel Gauge/Hour Meter – Through mid-2007

1. Orange 2. Blue 3. Black 4. White 5. Not used 6. Not used

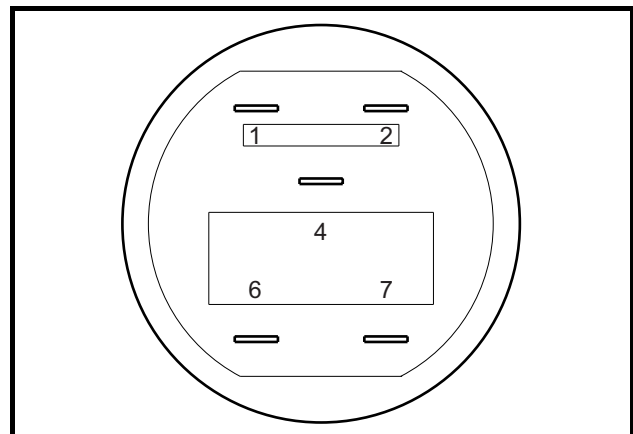

Figure 11-36 Fuel Gauge/Hour Meter – From mid-2007

1. Black(Jumper Wire From 6) 2. Blue 4. Orange 6. Black 7. White

Test Procedure 26A – Fuel Gauge (Through mid-2007)

1. Turn the key switch OFF and remove the key. Place the Forward/Reverse handle in the NEUTRAL position. Chock the wheels.

2. Remove the instrument panel to gain access to the back of the fuel gauge/hour meter. **See Key Switch Removal, Section 13, Page 13-14.**
3. Place a sheet of insulating material between the front frame and the electrical connections on the rear of the instrument panel to prevent contact between the two.
4. Disconnect the orange wire from the fuel gauge/hour meter.
5. Set a multimeter to 20 volts DC and place the red (+) probe of the multimeter on the positive post of the battery. Place the black (-) probe on the negative post of the battery. Record the voltage reading.
6. Set a multimeter to 20 volts DC and place the red (+) probe of the multimeter on the (2) terminal of the fuel gauge/hour meter with the blue wire. Place the black (-) probe on the (3) terminal of the fuel gauge/hour meter with the black wire (**Figure 11-37, Page 11-34**).
7. Connect the battery cables, positive (+) cable first, and tighten to 144 in-lb (16.3 N·m).
8. Turn the key switch ON. The voltage reading should be the same as the battery voltage reading recorded earlier. If not, check the continuity of the blue and black wires (**Figure 11-37, Page 11-34**).
9. The orange wire should remain disconnected for this step. With the black probe still on the (3) terminal of the fuel gauge/hour meter, place the red (+) probe of the multimeter on the (1) terminal of the fuel gauge/hour meter (**Figure 11-38, Page 11-34**). The voltage reading should be approximately 1.81 volts. If the reading is incorrect, replace fuel gauge/hour meter.

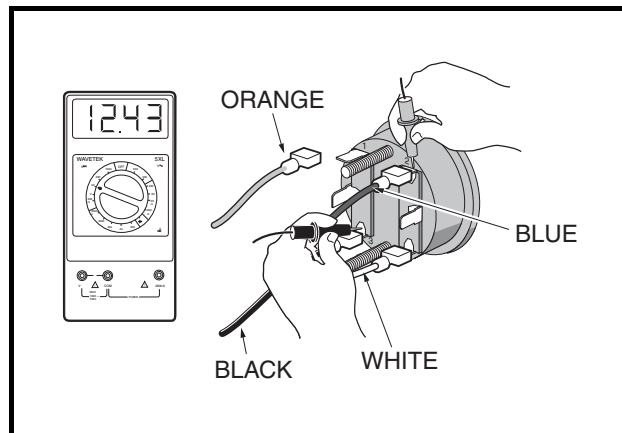

Figure 11-37 Test Fuel Gauge Continuity

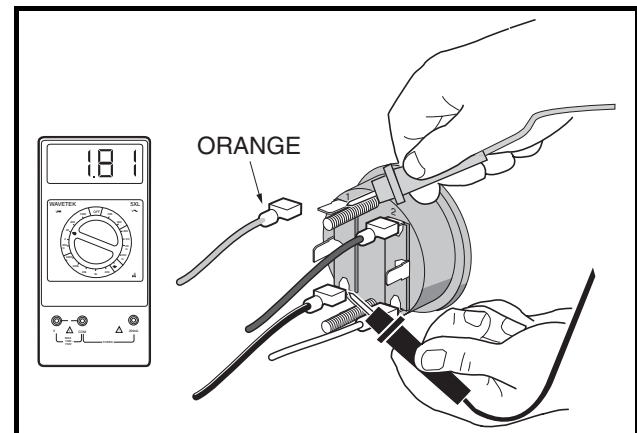

Figure 11-38 Test Fuel Gauge Voltage

Test Procedure 26B – Fuel Gauge (From mid-2007)

1. Turn the key switch OFF and remove the key. Place the Forward/Reverse handle in the NEUTRAL position. Chock the wheels.
2. Remove the instrument panel to gain access to the back of the fuel gauge/hour meter. **See Key Switch Removal, Section 13, Page 13-14.**
3. Place a sheet of insulating material between the front frame and the electrical connections on the rear of the instrument panel to prevent contact between the two.
4. Disconnect the orange wire from the fuel gauge/hour meter.
5. Set a multimeter to 20 volts DC and place the red (+) probe of the multimeter on the positive post of the battery. Place the black (-) probe on the negative post of the battery. Record the voltage reading.

6. Set a multimeter to 20 volts DC and place the red (+) probe on the (2) terminal of the fuel gauge/hour meter with the blue wire is connected. Place the black (-) probe on the (1) terminal of the fuel gauge/hour meter with the black wire (**Figure 11-39, Page 11-35**).
7. Connect the battery cables, positive (+) cable first, and tighten to 144 in-lb (16.3 N·m).
8. Turn the key switch ON. The voltage reading should be the same as the battery voltage reading recorded earlier. If not, check the continuity of the blue and black wires (**Figure 11-39, Page 11-35**).
9. The orange wire should remain disconnected for this step. Place the black probe of the multimeter on the (1) terminal of the fuel gauge/hour meter and place the red (+) probe on the (4) terminal of the fuel gauge/hour meter (**Figure 11-40, Page 11-35**). The voltage reading should be approximately 4.94 volts. If the reading is incorrect, replace the fuel gauge/hour meter.

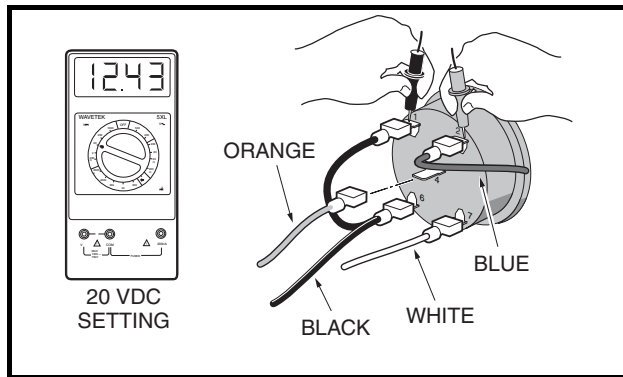

Figure 11-39 Fuel Gauge Voltage Test - Terminal 2

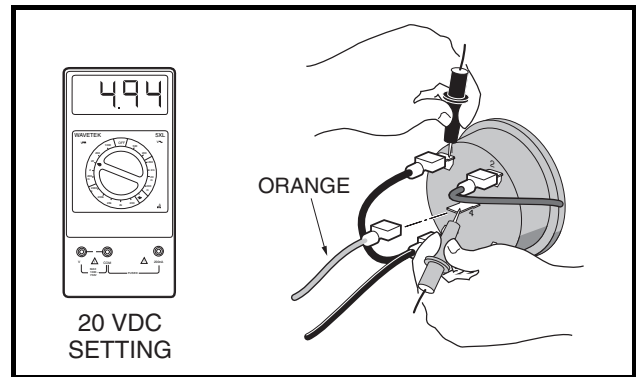

Figure 11-40 Fuel Gauge Voltage Test - Terminal 4

TEST PROCEDURE 27 – HOUR METER

See General Warning on page 1-1.

Two hour meters were used for model year 2007 (**Figure 11-35, Page 11-33 and Figure 11-36, Page 11-33**). The display and the terminal configuration on the back of the meter easily denotes the type. Follow the appropriate procedure. The display on the meter used through mid-2007 only appears when the key switch is ON whereas the display on the meter used from mid-2007 is always on. The meter used through mid-2007 has the orange wire connected to terminal 1 whereas the meter used from mid-2007 has it connected to terminal 4 in the center of the meter. In addition, the meter used through mid-2007 has one terminal (3) to ground it whereas the meter used from mid-2007 has two ground terminals (1 and 6) with a black jumper wire connecting them. **See following NOTE.**

NOTE: Keep the battery connected while performing this test procedure.

Test Procedure 27A – Hour Meter (Through mid-2007)

1. Place the Forward/Reverse handle in NEUTRAL. Chock the wheels.
2. Turn the key switch ON to verify the display appears.
3. Start the engine and let it idle. **See following DANGER.**

⚠ DANGER

- Do not operate vehicle in an enclosed area without proper ventilation. The engine produces carbon monoxide, which is an odorless, deadly poison.

4. With engine idling, the "hour glass" icon should flash slowly. If not, check the low oil warning light and the oil pressure switch. **See following NOTE. See also Test Procedure 22 – Oil Warning Light on page 11-31.**

NOTE: *The hour meter is designed to record actual engine running time and will not start adding increments until the engine is running and the oil pressure switch has opened.*

5. If the hour meter still does not function after the low oil warning light, oil pressure switch, and all of the appropriate wires have been checked for continuity, replace the fuel gauge/hour meter.

Test Procedure 27B – Hour Meter (From mid-2007)

1. Place the Forward/Reverse handle in NEUTRAL. Chock the wheels.
2. With the key switch OFF, check the hour meter display. It is powered by an internal battery and should always be on, even with the engine off and the key removed.
3. Start the engine and let it idle. **See following DANGER.**

DANGER

- **Do not operate vehicle in an enclosed area without proper ventilation. The engine produces carbon monoxide, which is an odorless, deadly poison.**

4. With engine idling, the "hour glass" icon should flash. If not, check the low oil warning light and the oil pressure switch. **See following NOTE. See also Test Procedure 22 – Oil Warning Light on page 11-31.**

NOTE: *The hour meter is designed to record actual engine running time and will not start adding increments until the engine is running and the oil pressure switch has opened.*

5. If the hour meter still does not function after the low oil warning light, oil pressure switch, and all of the appropriate wires have been checked for continuity, replace the fuel gauge/hour meter.

TEST PROCEDURE 28 – LIGHT SWITCH

See General Warning on page 1-1.

1. Turn the key switch OFF and remove the key. Place the Forward/Reverse handle in the NEUTRAL position. Chock the wheels.
2. Disconnect the battery cables as instructed. **See WARNING “To avoid unintentionally starting...” in General Warning on page 1-2.**
3. Remove the instrument panel. **See Key Switch Removal, Section 13, Page 13-14.**
4. Using a multimeter set on 20 volts DC, place alligator clips on the multimeter probes. Connect the red (+) probe to the light switch terminal with the blue wire connected to it (**Figure 11-41, Page 11-37**).
5. Connect the battery cables, positive (+) cable first.
6. Connect the black (–) probe of the multimeter to the negative (–) post of the battery.
7. With the light switch in the OFF position, the reading should be zero volts. With the light in the ON position, the reading should be between 11 and 12.5 volts. If there is no voltage reading, check continuity of the 10-gauge red wire from the fuse block to the solenoid. Check continuity of the 14-gauge yellow wire from the light switch to the fuse block. Check the fuse. **See Test Procedure 2 – Fuse on page 11-11.** If the headlight diode is functioning correctly, the wires and fuse show continuity and the readings are still incorrect, replace the switch. **See Light Switch Removal, Section 13, Page 13-29.**

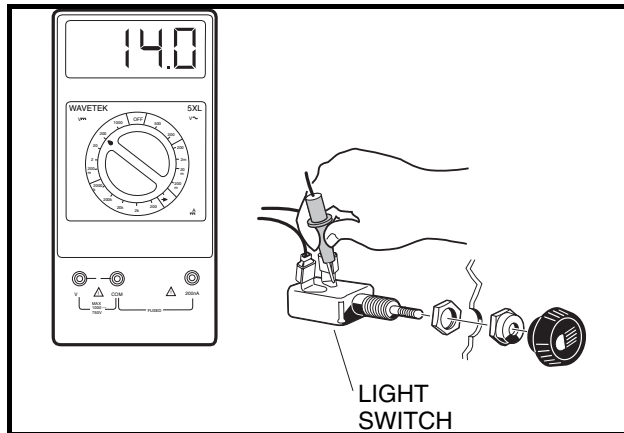

Figure 11-41 Light Switch Test

TEST PROCEDURE 29 – HEADLIGHT DIODE

See General Warning on page 1-1.

1. Turn the key switch OFF and remove the key. Place the Forward/Reverse handle in the NEUTRAL position. Chock the wheels.
2. Disconnect the battery cables as instructed. See WARNING “To avoid unintentionally starting...” in General Warning on page 1-2.
3. Remove the instrument panel. See Key Switch Removal, Section 13, Page 13-14.
4. Using a multimeter set on 20 volts DC, connect the red (+) probe to the light switch terminal with the yellow wire (Figure 11-42, Page 11-38).
5. Loosen the black wire connector (on the end of the long black wire) at the headlight diode assembly just enough to maintain the connection and yet expose part of the metal terminal in the connector. Place black (–) probe on the connector (Figure 11-42, Page 11-38).
6. Connect the battery, positive (+) cable first.
7. Pull the light switch to the ON position. The reading should be 11-12 volts. If there is no voltage reading, check continuity of the 16-gauge black wire from the headlight to the headlight diode. Check continuity of the 16-gauge black wire from headlight diode to the vehicle frame. If the wires show continuity and the readings are still incorrect, replace the headlight diode. See Voltage Limiter Removal, Section 13, Page 13-28.
8. With the Forward/Reverse handle in the NEUTRAL position and the wheels chocked, start the engine and press the accelerator pedal to the floor.
9. Push the light switch to the OFF position. The reading should be 14.7-15.3 volts.
10. Pull the light switch to the ON position. The reading should be 11-13 volts. If the reading does not drop from 14.5-15.5 volts to 11-13 volts, replace the voltage limiter.

TEST PROCEDURE 30 – VOLTAGE AT HEADLIGHT SOCKET

See General Warning on page 1-1.

NOTE: Keep the battery connected while performing this test procedure.

1. Turn the key switch OFF and remove the key. Place the Forward/Reverse handle in the NEUTRAL position. Chock the wheels.

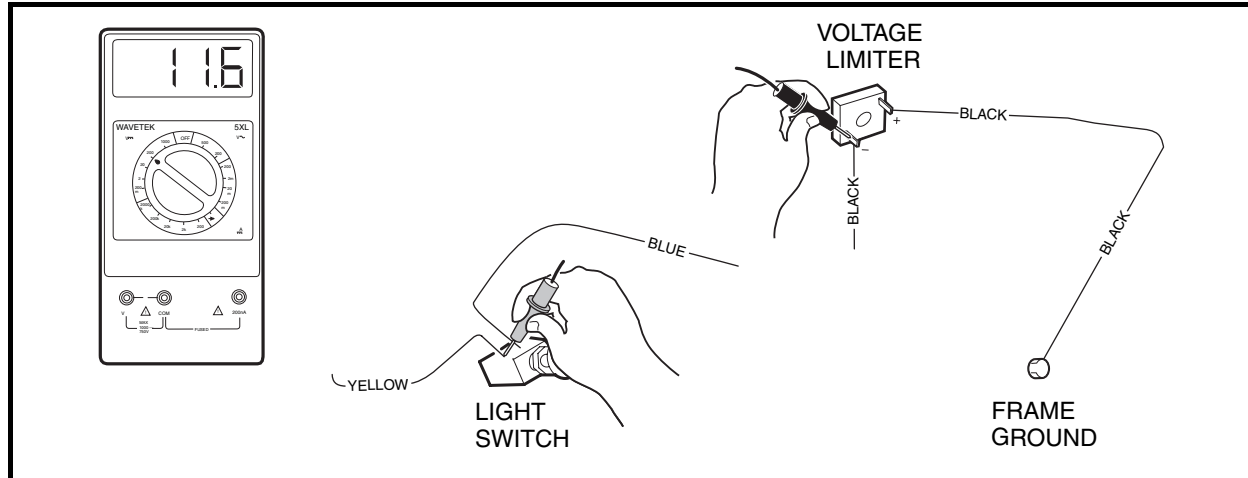

Figure 11-42 Headlight Diode Circuit Test

2. Inspect wires at light bulb socket. Make sure wires are securely fastened to the contacts inside socket.
3. Remove the wire harness from the headlight (**Figure 11-43, Page 11-38**).
4. Using a multimeter set to 20 volts DC, place the black (-) probe of multimeter into the black wire terminal of the wire harness. Place the red (+) probe into the blue wire terminal.
5. Pull the light switch to the ON position. If the multimeter reads approximately 12 volts, replace the bulb.
6. If there is no voltage reading at the wire harness, check continuity of the 16-gauge blue wire from the headlight to the light switch. Using a multimeter set to 20 volts DC, attach using an alligator clip, the black (-) probe of multimeter onto the negative battery terminal and place the red (+) probe into the blue wire terminal of the wire harness. If multimeter reading is approximately 12 volts, the blue wire has continuity.
7. Check continuity of the 16-gauge black wire from the headlight to the ground terminal. Using a multimeter set to 20 volts DC, place the black (-) probe of multimeter into the black wire terminal of the wire harness and attach using an alligator clip, the red (+) probe onto the positive battery terminal. If the multimeter reading is approximately 12 volts, the black wire has continuity.

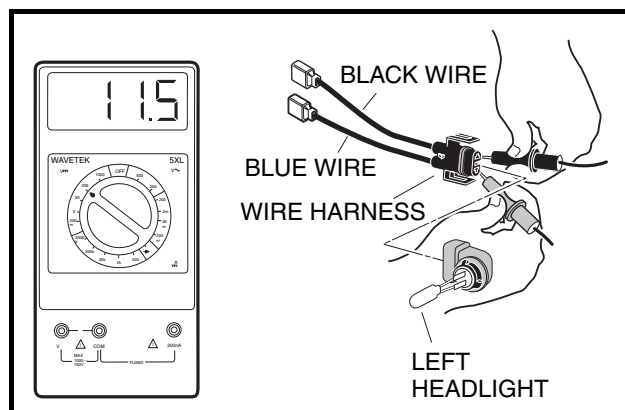

Figure 11-43 Check Voltage to Headlight Socket

SECTION 12 – TROUBLESHOOTING AND ELECTRICAL SYSTEM: 850 GAS

▲ DANGER

- See General Warning on page 1-1.

▲ WARNING

- See General Warning on page 1-1.

GENERAL INFORMATION

This section contains the information required to correctly troubleshoot the vehicle. A troubleshooting guide is provided for general troubleshooting.

In addition to troubleshooting, this section contains general information on the electrical system and the circuits of the electrical system.

TROUBLESHOOTING GUIDE

The following troubleshooting guide will be helpful in identifying operating difficulties should they occur. The guide includes the symptom, probable cause(s) and suggested checks. The procedures used in making these checks can be found in the referenced sections of the maintenance and service manual.

TROUBLESHOOTING GUIDE		
SYMPTOM	POSSIBLE CAUSES	CORRECTIVE ACTION
Engine does not start easily.	Spark plug is partially fouled or in poor condition	Section 15 – Engine
	Spark plug wire is damaged or loose	Section 15 – Engine
	Loose wire connection at ignition coil or RPM limiter	Section 12 – Troubleshooting and Electrical System: 850 Gas Test Procedures 13, 14, and 15
	Intermittent ignition coil failure	Section 12 – Troubleshooting and Electrical System: 850 Gas Test Procedures 13, 14, and 15
	Low cylinder compression	Section 15 – Engine
	Water or dirt in the fuel system and/or carburetor; dirty or clogged fuel filter	Section 16 – Fuel System: Gasoline Vehicle
	Carburetor improperly adjusted	Section 16 – Fuel System: Gasoline Vehicle
	Starter/generator belt is slipping	See Belt Tension Adjustment on page 14-11.
Troubleshooting Guide continued on next page...		

TROUBLESHOOTING GUIDE		
SYMPTOM	POSSIBLE CAUSES	CORRECTIVE ACTION
Engine starts but does not run smoothly.	Spark plug is fouled or in poor condition	Section 15 – Engine
	Spark plug wire is damaged or loose	Section 15 – Engine
	Intermittent ignition coil failure	Section 12 – Troubleshooting and Electrical System: 850 Gas Test Procedures 13, 14, and 15
	Water or dirt in the fuel system and/or carburetor; dirty or clogged fuel filter	Section 16 – Fuel System: Gasoline Vehicle
	Fuel pump malfunction; fuel pressure to carburetor too low	Section 16 – Fuel System: Gasoline Vehicle
Engine turns but fails to start.	Fuel tank is empty	Section 16 – Fuel System: Gasoline Vehicle
	Fuel line or filters clogged	Section 16 – Fuel System: Gasoline Vehicle
	Fouled spark plug	Section 15 – Engine
	Spark plug wire damaged or loose	Section 15 – Engine
	Loose wire connection at ignition coil or RPM limiter	Section 12 – Troubleshooting and Electrical System: 850 Gas Test Procedures 13, 14, and 15
	Ignition coil or RPM limiter failed	Section 12 – Troubleshooting and Electrical System: 850 Gas Test Procedures 13, 14, and 15
	Engine flooded with fuel as result of excess choking	See Section 3 – General Information. See Choke.
	Kill circuit grounded	Section 12 – Troubleshooting and Electrical System: 850 Gas Test Procedures 16, 17, and 18
	Fuel pump malfunction or failure	Section 16 – Fuel System: Gasoline Vehicle
Engine overheats.	Fan screen is partially blocked or plugged	Section 15 – Engine
	Governor is improperly adjusted	Section 16 – Fuel System: Gasoline Vehicle
	Carburetor is too lean; check main jet size	Section 16 – Fuel System: Gasoline Vehicle
Engine pre-ignites.	Excessive carbon deposits on piston head or in combustion chamber	Section 15 – Engine
	Spark plug heat range is incorrect	Section 15 – Engine
	Unsuitable or contaminated fuel	Section 16 – Fuel System: Gasoline Vehicle
Troubleshooting Guide continued on next page...		

TROUBLESHOOTING GUIDE		
SYMPTOM	POSSIBLE CAUSES	CORRECTIVE ACTION
Loss of engine power.	Exhaust valve is restricted with carbon deposit	Section 15 – Engine
	Muffler or exhaust pipe restricted with carbon or other substance	Section 17 – Exhaust System: Gasoline Vehicles
	Ignition coil failed	Section 12 – Troubleshooting and Electrical System: 850 Gas Test Procedures 13, 14, and 15
	Air filter is dirty or clogged	Section 16 – Fuel System: Gasoline Vehicle
	Governor is improperly adjusted	Section 16 – Fuel System: Gasoline Vehicle
Loss of engine power, continued.	Throttle linkage out of adjustment	Section 16 – Fuel System: Gasoline Vehicle
	Low cylinder compression	Section 15 – Engine
	Spark plug failed	Section 15 – Engine
	Restricted fuel flow	Section 16 – Fuel System: Gasoline Vehicle
	Torque converter is not backshifting properly	Section 20 – Torque Converter: Gasoline Vehicle
Spark plug fouls repeatedly.	Incorrect plug	Section 15 – Engine
	Spark plug wire is damaged	Section 15 – Engine
	Unsuitable fuel, or incorrect (rich) fuel mixture	Section 16 – Fuel System: Gasoline Vehicle
	Ignition coil failed	Section 12 – Troubleshooting and Electrical System: 850 Gas Test Procedures 13, 14, and 15
	Dirt entering combustion chamber	Check intake system for leaks. Section 16 – Fuel System: Gasoline Vehicle
	Rings are heavily worn, low cylinder pressure	Section 15 – Engine
Carburetor floods.	Inlet valve or seat is leaking, dirty, worn, or damaged	Section 16 – Fuel System: Gasoline Vehicle
	Float is damaged and filled with fuel	Section 16 – Fuel System: Gasoline Vehicle
	Float needle valve not functioning properly	Section 16 – Fuel System: Gasoline Vehicle
	Carburetor vent is clogged	Section 16 – Fuel System: Gasoline Vehicle
Troubleshooting Guide continued on next page...		

TROUBLESHOOTING GUIDE		
SYMPTOM	POSSIBLE CAUSES	CORRECTIVE ACTION
Starter fails to operate.	Neutral lockout switch is in the wrong position	Section 12 – Troubleshooting and Electrical System: 850 Gas
	Fuse is blown	Section 12 – Troubleshooting and Electrical System: 850 Gas Test Procedure 2
	Battery is dead	Section 12 – Troubleshooting and Electrical System: 850 Gas Test Procedure 1
	Starter control circuit is not operating	Section 12 – Troubleshooting and Electrical System: 850 Gas
	Starter/generator failed	Section 12 – Troubleshooting and Electrical System: 850 Gas Test Procedure 7
	Starter solenoid failed	Section 12 – Troubleshooting and Electrical System: 850 Gas Test Procedure 6
	Accelerator pedal limit switch failed	Section 12 – Troubleshooting and Electrical System: 850 Gas Test Procedure 5
	Key switch failed	Section 12 – Troubleshooting and Electrical System: 850 Gas Test Procedure 4
	Neutral lockout limit switch failed	Section 12 – Troubleshooting and Electrical System: 850 Gas Test Procedure 7
	Loose or broken wire in starter/generator circuit	Section 14 – Electrical Components: 850 Gasoline Vehicle Starter/Generator on page 14-1
	Cylinder and/or crankcase flooded with fuel	Section 16 – Fuel System: Gasoline Vehicle
Starter/generator does not charge battery.	Loose or broken wire in the starter/generator circuit	Section 12 – Troubleshooting and Electrical System: 850 Gas Test Procedure 10
	Generator field coil is shorted	Section 12 – Troubleshooting and Electrical System: 850 Gas Test Procedure 10
	Brushes are worn or commutator is dirty	Section 14 – Electrical Components: 850 Gasoline Vehicle Starter/Generator on page 14-1
	Starter/generator belt is loose or slipping	Section 14 – Electrical Components: 850 Gasoline Vehicle Belt Tension Adjustment on page 14-11
	Voltage regulator failed	Section 12 – Troubleshooting and Electrical System: 850 Gas Test Procedure 11
	Battery failed	Section 12 – Troubleshooting and Electrical System: 850 Gas Test Procedure 1
Troubleshooting Guide continued on next page...		

TROUBLESHOOTING GUIDE		
SYMPTOM	POSSIBLE CAUSES	CORRECTIVE ACTION
Transmission does not engage or disengage smoothly.	Transmission shifter linkage is binding or is out of adjustment	Section 19 – Unitized Transaxle: 850 Gasoline Vehicle
	Insufficient (low) level of lubricant or wrong type of lubricant in transmission	Section 19 – Unitized Transaxle: 850 Gasoline Vehicle
	Internal gears are damaged or worn	Section 19 – Unitized Transaxle: 850 Gasoline Vehicle
	Synchronizer rings are worn, damaged or jammed	Section 19 – Unitized Transaxle: 850 Gasoline Vehicle
Excessive vehicle vibration.	Engine mounting nuts or bolts are loose	Section 15 – Engine
	Snubber on frame is worn or damaged	Section 15 – Engine
	Misaligned muffler mounting clamp	Section 17 – Exhaust System: Gasoline Vehicles
	Damaged drive belt or starter belt	Section 20 – Torque Converter: Gasoline Vehicle
	Damaged drive clutch	Section 20 – Torque Converter: Gasoline Vehicle
	Damaged starter/generator pulley	Section 14 – Electrical Components: 850 Gasoline Vehicle Starter/Generator on page 14-1
	RPM setting is incorrect	Section 16 – Fuel System: Gasoline Vehicle Engine RPM Adjustment on page 16-12
Torque converter does not shift smoothly.	Drive belt is worn, cracked, glazed, or frayed	Section 20 – Torque Converter: Gasoline Vehicle
	Drive clutch malfunction	Section 20 – Torque Converter: Gasoline Vehicle
	Governor is sticking	Section 19 – Unitized Transaxle: 850 Gasoline Vehicle
Engine won't stop running.	Kill circuit wire is disconnected from the ignition coil	Section 12 – Troubleshooting and Electrical System: 850 Gas Test Procedure 12
	Accelerator pedal linkage out of adjustment causing engine kill limit switch not to activate	Section 16 – Fuel System: Gasoline Vehicle
	Carburetor is too lean; check main and pilot jet sizes	Section 16 – Fuel System: Gasoline Vehicle
	Carburetor throttle stop screw out of adjustment	Section 16 – Fuel System: Gasoline Vehicle

WIRING DIAGRAM

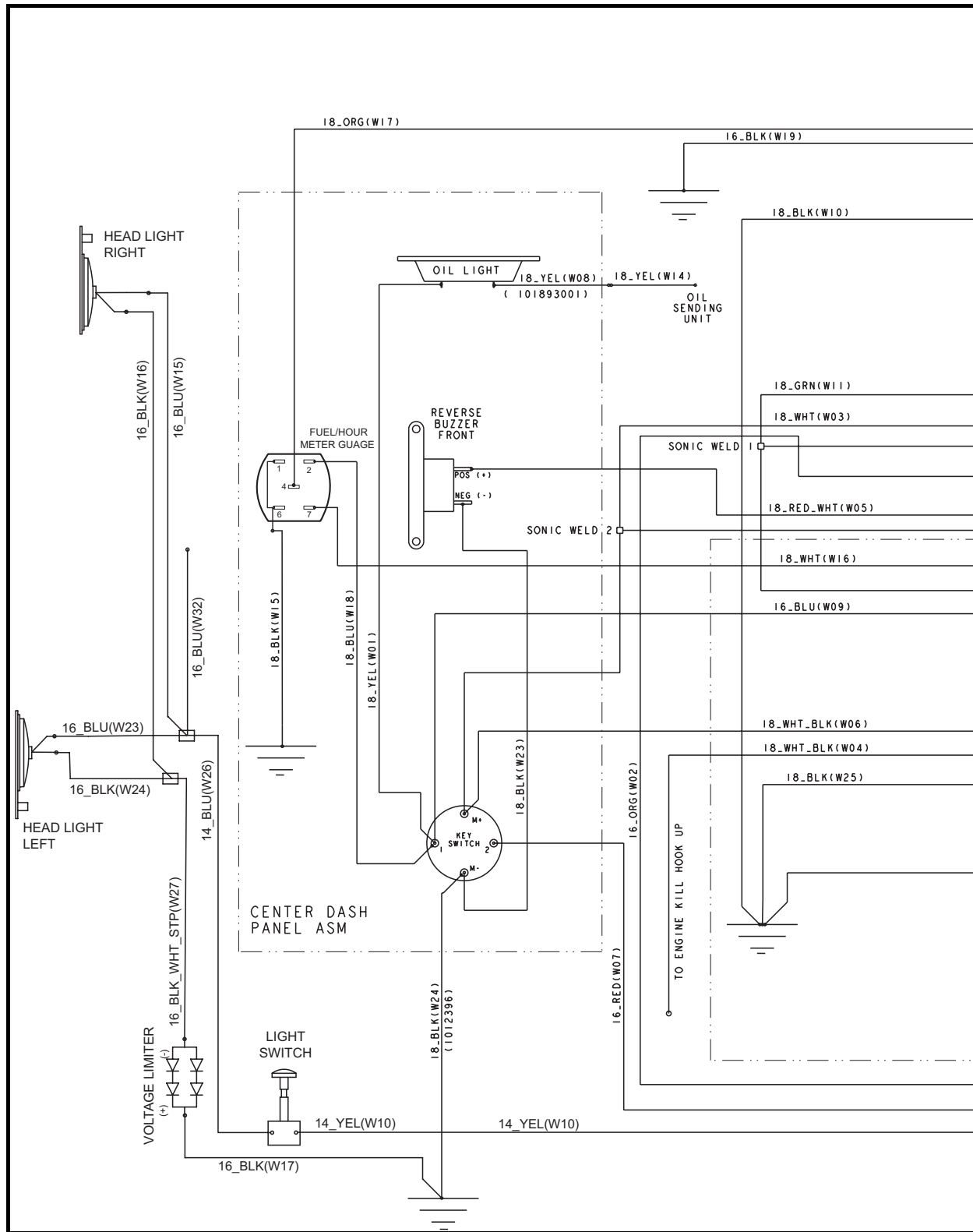

Figure 12-1 Wiring Diagram for Pedal-Start Gasoline Vehicles

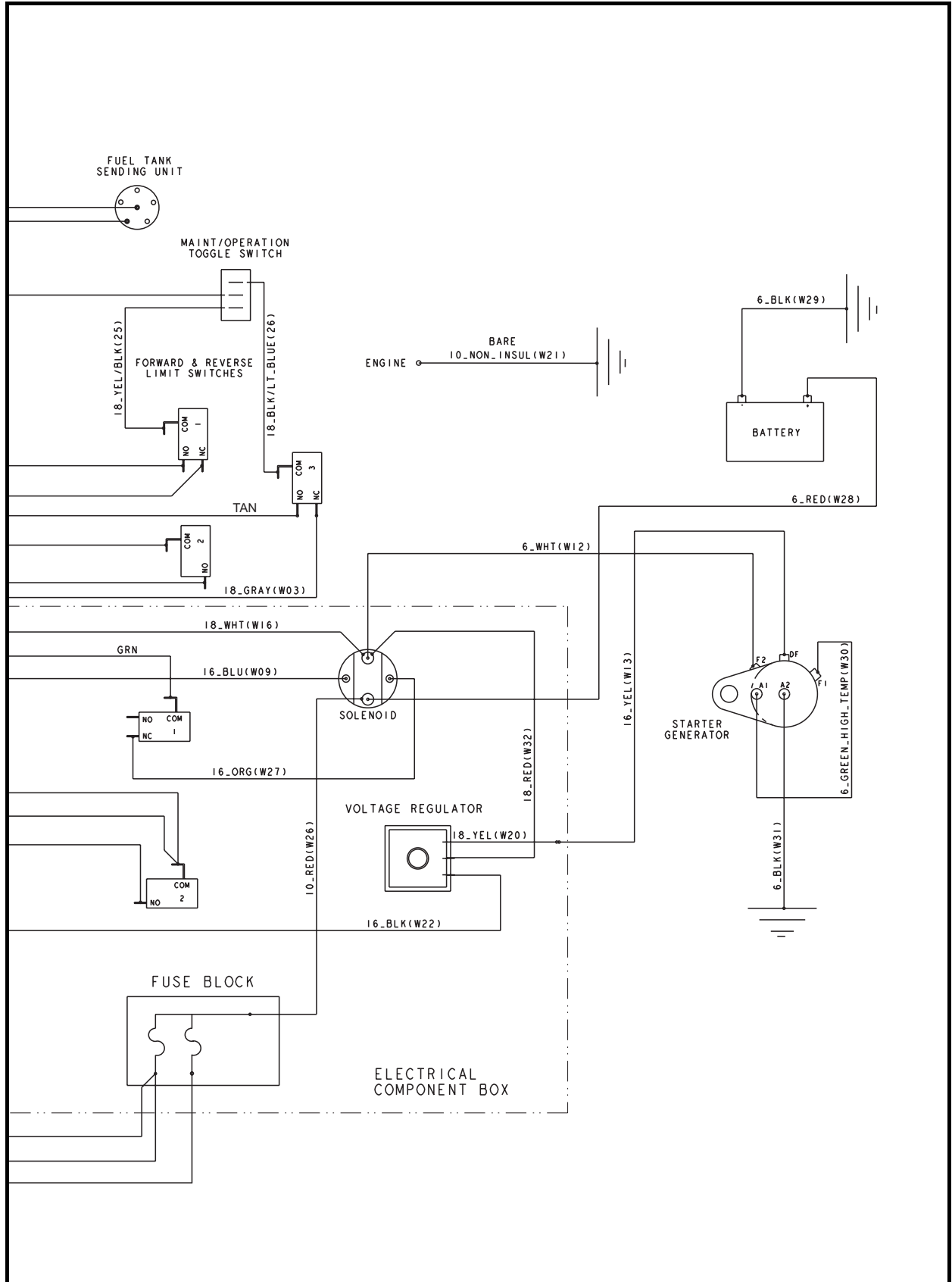

Figure 12-2 Wiring Diagram for Pedal-Start Gasoline Vehicles

ELECTRICAL SYSTEM

The electrical system on the gasoline vehicle is 12 volts DC with negative (–) ground to frame, and consists of the following circuits that are easily identified:

- Starter Circuit
- Generator Circuit
- Engine Ignition Circuit
- Engine Kill Circuit
- Reverse Buzzer Circuit
- Low Oil Warning Light Circuit
- Neutral Lockout Circuit
- Fuel Gauge and Sending Unit Circuit
- Hour Meter Circuit
- Lighting Circuit

Recognizing and understanding the function of each of these circuits will help to quickly isolate the source of an electrical problem. Use the appropriate test procedure to correct the electrical problem. **See Test Procedures on page 12-8.**

For a complete wiring diagram, see page 12-6.

TEST PROCEDURES

INDEX OF TEST PROCEDURES

1. Battery
2. Fuse
3. Ground Cables
4. Key Switch (Starter Circuit)
5. Accelerator Pedal Limit Switch
6. Solenoid
7. Neutral Lockout Limit Switch
8. Starter/Generator (Starter Function)
9. Wire Continuity
10. Starter/Generator (Generator Function)
11. Voltage Regulator
12. Disconnected Kill Wire
13. Ignition Spark
14. RPM Limiter
15. Ignition Coil
16. Kill Limit Switch
17. Key Switch (Engine Kill Circuit)

18. Engine Kill Wire
19. Reverse Buzzer Limit Switch
20. Reverse Buzzer
21. Low Oil Warning Light
22. Oil Level Sensor
23. Neutral Lockout Switch
24. Battery Test (Under Load)
25. Fuel Level Sending Unit
26. Fuel Gauge
27. Hour Meter
28. Light Switch
29. Voltage Limiter
30. Voltage at Headlight Socket

TEST PROCEDURE 1 – BATTERY

See General Warning on page 1-1.

DANGER

- Due to the danger of an exploding battery, wear a full face shield and rubber gloves when working near a battery.
- Battery – Explosive gases! Do not smoke. Keep sparks and flames away from the vehicle and service area. Ventilate when charging or operating vehicle in an enclosed area. Wear a full face shield and rubber gloves when working on or near batteries.
- Battery – Poison! Contains acid! Causes severe burns. Avoid contact with skin, eyes, or clothing. Antidotes:
 - External: Flush with water. Call a physician immediately.
 - Internal: Drink large quantities of milk or water. Follow with milk of magnesia or vegetable oil. Call a physician immediately.
 - Eyes: Flush with water for 15 minutes. Call a physician immediately.

NOTE: The battery must be properly maintained and fully charged in order to perform the following test procedures. Battery maintenance procedures, including watering information and allowable mineral content, can be found in section 14 of this manual. See **Battery on page 14-30**.

1. Place the Forward/Reverse handle in the NEUTRAL position and the neutral lockout switch in the MAINTENANCE position. Chock the wheels.
2. Check for loose or corroded battery terminal connections. Remove the negative (–) cable first and clean, tighten, and replace connections as necessary.

Hydrometer Test

A hydrometer (CCI P/N 1011478) measures the specific gravity. The greater the specific gravity, the greater the state of charge of the battery. A fully charged battery should read between 1.250 and 1.280 at 80 °F (27 °C). Never add acid to the battery to obtain a higher specific gravity (**Figure 12-3, Page 12-10**).

⚠ CAUTION

- Do not allow battery acid from battery caps or hydrometer to drip onto the body. Battery acid will cause permanent damage. Wash off immediately.

Performing the Hydrometer Test

1. Be sure that the battery has sufficient water to cover the plates by approximately 1/2 inch (12.7 mm) and is fully charged prior to beginning the test. If water must be added, recharge the battery before performing the hydrometer test (**Figure 12-4, Page 12-10**).
2. Remove the vent cap.
3. Using a battery thermometer (CCI P/N 1011767), record the electrolyte temperature of a center cell.
4. Squeeze the rubber bulb of the hydrometer and insert into the cell. Slowly release the bulb, drawing electrolyte up into the glass tube of the hydrometer.
5. When the float rises off the bottom, adjust the electrolyte level so that the float rides free of the bottom but does not strike the bottom of the rubber bulb. Remove the hydrometer from the cell and release the pressure from the bulb.
6. Hold the hydrometer vertically, ensuring that the float is not contacting the sides of the glass tube. Hold the hydrometer at eye level and read the scale at the level of electrolyte (**Figure 12-3, Page 12-10**).
7. Record the reading.
8. Return the electrolyte to the cell from which it was taken. Replace vent cap.
9. Repeat steps 2 through 8 on all cells.

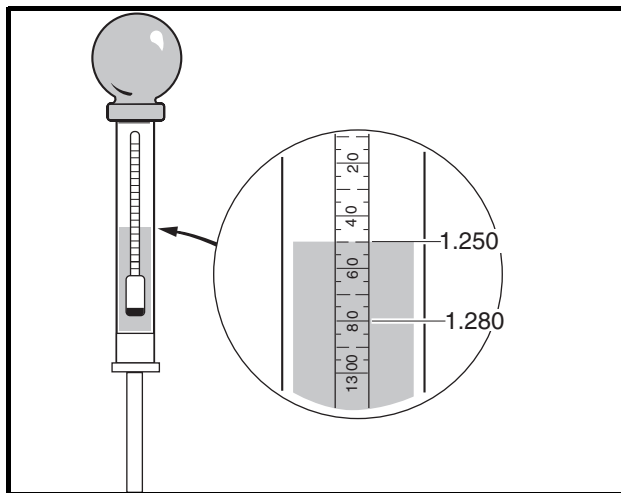

Figure 12-3 Hydrometer Test

View at eye level.

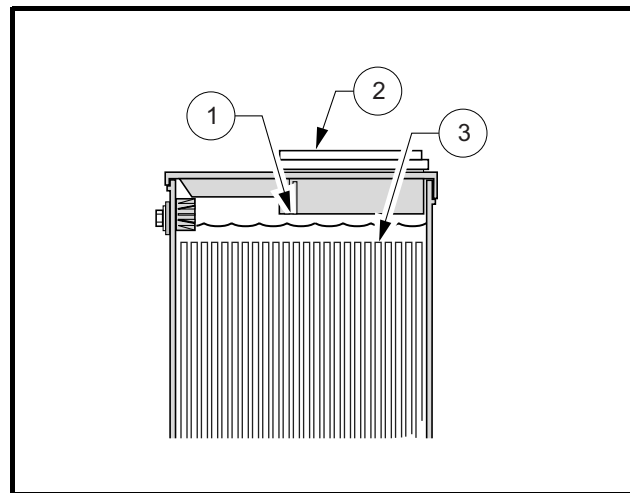

Figure 12-4 Battery Electrolyte Level

1. Level Indicator 2. Cap 3. Plates
Electrolyte level at least 1/2 inch (13 MM) above plates or to level indicator.

Hydrometer Calibration

Most hydrometers are calibrated to read correctly at 80 °F (27 °C). The readings obtained as described above must be corrected for temperature. For each 10 °F (5.6 °C) above 80 °F (27 °C), add 0.004 to the reading. For each 10 °F (5.6 °C) below 80 °F (27 °C), subtract 0.004 from the reading.

Interpreting the Results of the Hydrometer Test

The approximate state of charge can be determined by referring to the following table:

SPECIFIC GRAVITY (TEMPERATURE CORRECTED)	APPROXIMATE STATE OF CHARGE
1.250-1.280	100%
1.220-1.240	75%
1.190-1.210	50%
1.160-1.180	25%

If the difference between the cells is 0.020 or more, the low cell should be suspected. It may require a catch-up charge or it may be a weak cell. When the variations between cells reach 0.050 or more, the battery should be replaced.

Voltage Test

1. Take a voltage reading with a multimeter set to 20 VDC by placing the red (+) probe on the positive (+) battery post and the black (-) probe on the negative (-) battery post. If it shows less than 12.4 volts, or if the lowest specific gravity reading from the Hydrometer Test is less than 1.225, recharge the battery. If battery voltage is greater than 12.4 volts and specific gravity is greater than 1.225, the problem is not with the battery. If the battery does not reach 12.4 volts, or if the specific gravity of a cell is still less than 1.225 after charging, replace the battery. **See following NOTE.**

NOTE: A fully charged battery that is in good condition should have a specific gravity of at least 1.225 in all cells, and the difference in the specific gravity of any two cells should be less than 50 points. Open circuit voltage should be at least 12.4 volts.

Load Test

1. Connect a 160-ampere load tester to the battery posts.
2. Turn the switch on the load tester to the ON position.
3. Read the battery voltage after the load tester has been turned ON for 15 seconds. Compare the battery's voltage reading with the following table. Make sure you have the correct ambient temperature.

IF TEMPERATURE IS	MINIMUM CRANKING VOLTAGE
70 °F (20 °C and above)	9.6 V
60 °F (16 °C)	9.5 V
50 °F (10 °C)	9.4 V
40 °F (4 °C)	9.3 V
30 °F (-1 °C)	9.1 V
20 °F (-7 °C)	8.9 V
10 °F (-12 °C)	8.7 V
0 °F (-18 °C)	8.5 V

- If the battery is found to be good, or if the electrical problem continues after the battery has been replaced with a good one, test the electrical circuits.

TEST PROCEDURE 2 – FUSE

See General Warning on page 1-1.

The fuse (red 10-amp) is located in the electrical component box.

- Disconnect the battery cables as instructed. See **WARNING “To avoid unintentionally starting...”** in **General Warning on page 1-2**.
- Remove the cover from the electrical component box.
- Ensure that wires are connected correctly and are tight. If they are not, rewire or tighten as necessary.
- Remove fuse to be tested from the fuse block. See **Fuse Removal on page 14-14**. The red 10-amp fuse protects the solenoid for the starter (cranking) circuit. The 20-amp fuse at the yellow wire connection protects the headlights and brake lights (if equipped). The fuse at the red/white wire connection protects the horn.
- Connect the probes of a multimeter, set to 200 ohms, to the fuse terminals. The reading should be continuity. If there is no continuity, determine and repair the cause of the fuse failure. Replace the fuse with a properly rated new one.

TEST PROCEDURE 3 – GROUND CABLES

See General Warning on page 1-1.

- Disconnect the battery cables as instructed. See **WARNING “To avoid unintentionally starting...”** in **General Warning on page 1-2**.
- Check the starter/generator ground cable.
 - Set the multimeter to 200 ohms. Place the red (+) probe on the (A2) terminal of the starter/generator and place the black (–) probe on the vehicle frame (**Figure 12-5, Page 12-12**). The reading should be continuity. If the reading is incorrect, clean and tighten cable connections. If the connections are good and the reading is incorrect, repair or replace the cable.
- Check the engine ground cable.
 - Place the red (+) probe of the multimeter on the ground cable terminal end located on the oil filler bracket on the engine (**Figure 12-6, Page 12-12**). Place the black (–) probe on the vehicle frame. The reading should be continuity. If the reading is incorrect, clean and tighten cable connections. If the connections are good and the reading is incorrect, repair or replace the cable.

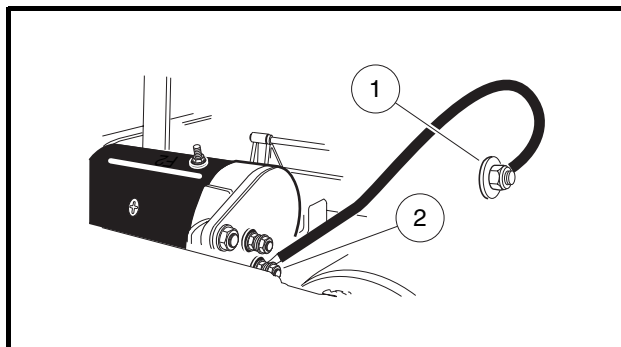

Figure 12-5 Starter/Generator Ground Cable Test

1. Ground to Chassis 2. A2 Terminal

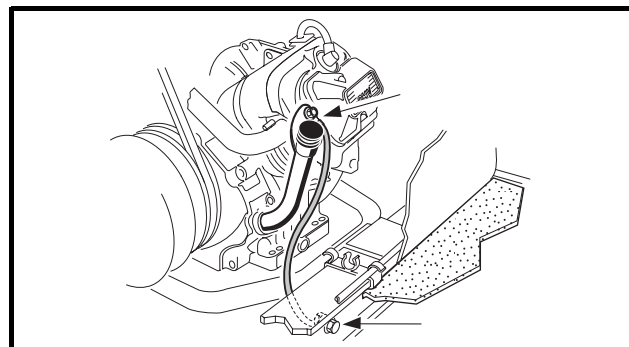

Figure 12-6 Engine Ground Cable Test

Place test probes at each end of ground cable.

4. Check voltage regulator ground connection (at battery frame ground). Make sure it is clean and tight.
5. Check the battery ground cable.
 - 5.1. A 6-gauge black cable connects the negative (–) battery post to the frame. The frame connection should be clean and tight. Visual inspection of the connection on the frame is very difficult. The best check for tightness is to pull on the black cable. If the cable moves at the connection end, disassemble the frame connection and clean the bolt, ring terminal, and nut. Reinstall the frame connection.
 - 5.2. Set the multimeter to 200 ohms. Place the red (+) probe on the unconnected end of the 6-gauge black cable, and place the black (–) probe on the vehicle frame (**Figure 12-7, Page 12-13**). The reading should be continuity. If the reading is incorrect, ensure that terminal connections are clean and tight. If the connections are good and the reading is incorrect, repair or replace the cable.

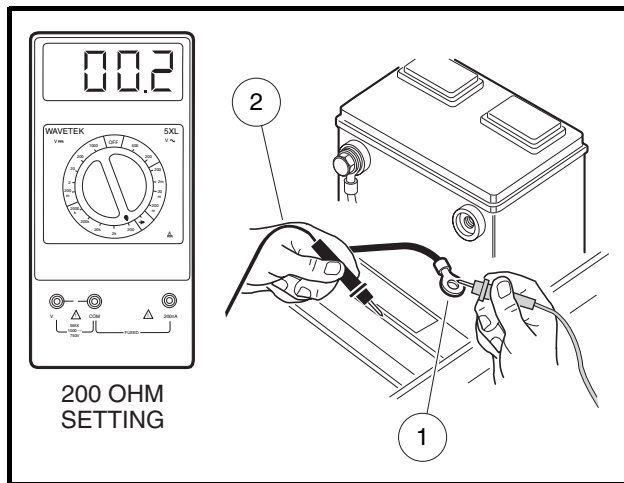

Figure 12-7 Battery Ground Cable Test

1. Disconnect the 6-gauge black wire from the battery. Place red (+) probe on disconnected end of cable.
2. Place black (–) probe on frame.

TEST PROCEDURE 4 – KEY SWITCH (STARTER CIRCUIT)

See **General Warning** on page 1-1.

1. Disconnect the battery cables as instructed. See **WARNING “To avoid unintentionally starting...”** in **General Warning** on page 1-2.
2. Remove the center dash assembly. See **Key Switch Removal** on page 14-12.
3. Ensure that the wires are connected correctly and are tight. If they are not, rewire or tighten as necessary.
4. Insert the key and turn the key to ON. Place the red (+) probe of the multimeter on the (2) terminal and the black (–) probe on the (1) terminal of the key switch. The reading should be continuity. If the reading is incorrect, replace the key switch (**Figure 12-8, Page 12-14**).

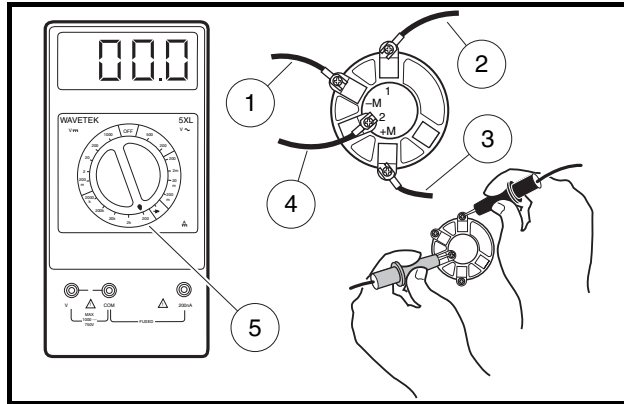

Figure 12-8 Key Switch Starter Circuit Test – For Pedal-Start Vehicles

1. Black/White 2. Blue 3. White/Black 4. Red 5. 200 Ohm Setting

TEST PROCEDURE 5 – ACCELERATOR PEDAL LIMIT SWITCH

See General Warning on page 1-1.

The accelerator pedal limit switch is the top switch located in the electrical component box. There is an 18-gauge green wire and an 18-gauge orange wire connected to this limit switch.

1. Disconnect the battery cables as instructed. See **WARNING “To avoid unintentionally starting...”** in **General Warning on page 1-2.**
2. Check for proper wiring and tight connections (**Figure 12-1, Page 12-6**).
3. Set the multimeter to 200 ohms. Place the red (+) probe on the common (COM) terminal (green wire) of the limit switch and place the black (–) probe on the normally closed (NC) terminal (orange wire) of the limit switch.
4. Make sure the battery is disconnected. With the key switch in the OFF position, the Forward/Reverse handle in NEUTRAL, and the accelerator pedal in the UP position, the reading should be no continuity. With the accelerator pedal pressed, the reading should be continuity. If readings are incorrect, replace the switch.

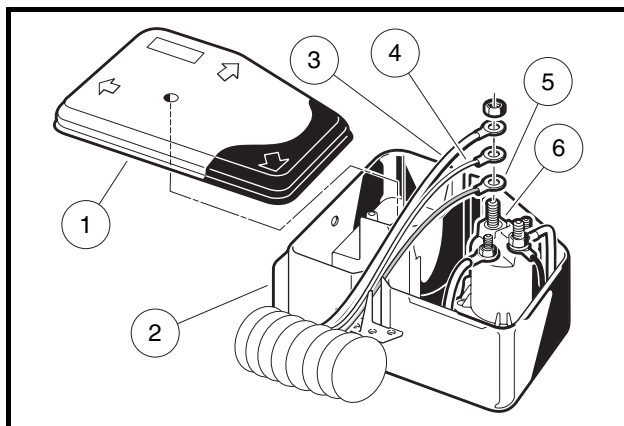

Figure 12-9 Solenoid Wire Removal

1. Cover 2. Electrical Component Box 3. 6 Ga. White Wire 4. 18 Ga. White Wire 5. 18 Ga. Red Wire 6. Solenoid

TEST PROCEDURE 6 – SOLENOID

See General Warning on page 1-1.

1. Disconnect the battery cables as instructed. See **WARNING “To avoid unintentionally starting...”** in **General Warning on page 1-2**.
2. Remove the electrical component box cover.
3. Ensure that the wires are connected correctly and are tight. If they are not, rewire or tighten as necessary.
4. Set a multimeter to 200 ohms. Place the red (+) probe on one of the small posts of the solenoid and place the black (–) probe on the other small post. The reading should be 14 to 16 ohms. If the reading is not within limits, replace the solenoid.
5. Remove the 6-gauge white wire, the 16-gauge red wire, and 16-gauge white wire from the large post of the solenoid. Do not allow the wires to touch the frame or other components of the vehicle (**Figure 12-9, Page 12-14**).
6. Set the multimeter to 200 ohms. Connect the red (+) probe to one of the large posts of the solenoid and connect the black (–) probe to the other large post (**Figure 12-10, Page 12-15**).
7. Connect battery cables, positive (+) cable first, and tighten hardware to 144 in-lb (16 N·m).
8. Place the Forward/Reverse handle in the NEUTRAL position and the neutral lockout switch in the MAINTENANCE position. Turn the key switch to the ON position. With the accelerator in the UP position, the reading on the multimeter should be no continuity. Press the accelerator pedal and listen for the solenoid click. There should be continuity. If either reading is incorrect, replace the solenoid.
9. With the Forward/Reverse handle still in NEUTRAL and the neutral lockout switch in the MAINTENANCE position, set the multimeter to 20 volts DC and place the red (+) probe on the large post that does not have wires connected to it. Place the black (–) probe on the vehicle frame. Turn key switch to the ON position, press accelerator pedal, and listen for solenoid click. The meter should read full battery voltage. If the reading is incorrect, replace the solenoid (**Figure 12-11, Page 12-15**).
10. Disconnect the 6-gauge black wire from the negative (–) post of the battery before reconnecting the wires to the solenoid.

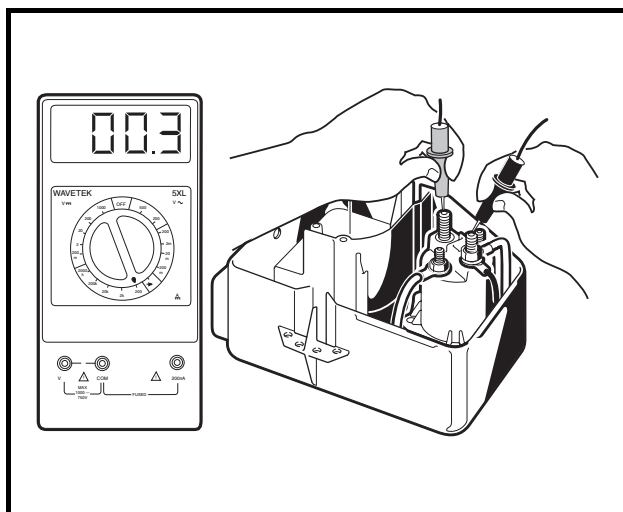

Figure 12-10 Solenoid Continuity Test

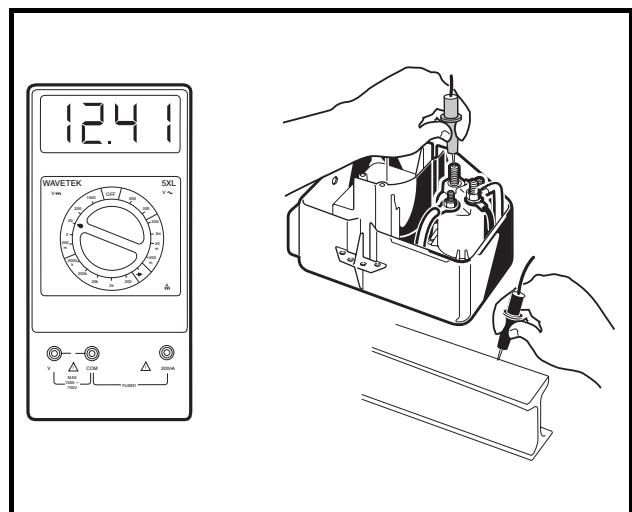

Figure 12-11 Solenoid Ground Test

TEST PROCEDURE 7 – NEUTRAL LOCKOUT LIMIT SWITCH

See General Warning on page 1-1.

This switch is located on the Forward/Reverse switch assembly. A black/light blue wire, a gray wire, and a tan wire are connected to this limit switch.

1. Disconnect the battery cables as instructed. See **WARNING “To avoid unintentionally starting...”** in **General Warning on page 1-2.**
2. Check for proper wiring and tight connections.
3. Set the multimeter to 200 ohms. Place the red (+) probe of the multimeter on the common (COM) terminal of the limit switch. Place the black (–) probe on the normally open (NO) terminal of the switch. Without the lever pressed, the reading should be no continuity. Press the lever, and the reading should be continuity. If either reading is incorrect, replace the limit switch (**Figure 12-12, Page 12-16**).
4. Check to be sure the lobe on the cam is pressing the neutral lockout limit switch as the Forward/Reverse shifter is being shifted. The limit switch should make an audible click as it is pressed. If it does not, check for wear on the cam lobe and replace cam if necessary.

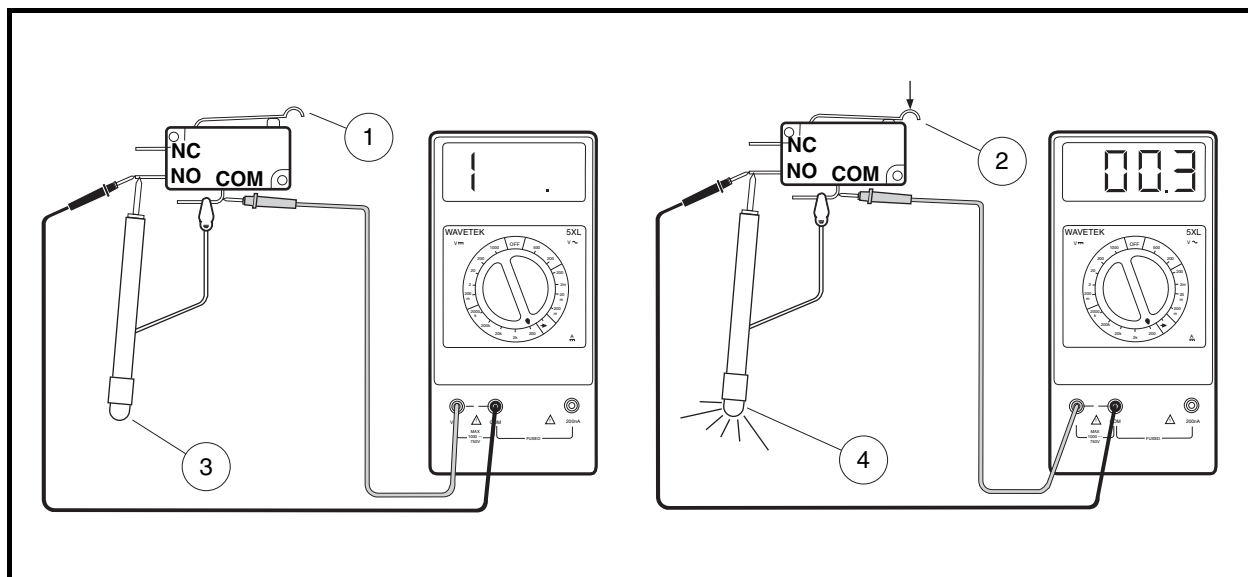

Figure 12-12 Neutral Lockout Limit Switch Test

1. Lever Up 2. Lever Depressed 3. Tester light is OFF. Meter reads 1. 4. Tester light is ON. Meter reads approx. zero ohms.

TEST PROCEDURE 8 – STARTER/GENERATOR (STARTER FUNCTION)

See General Warning on page 1-1.

1. Disconnect the battery cables as instructed. See **WARNING “To avoid unintentionally starting...”** in **General Warning on page 1-2.**
2. Ensure that wires are connected correctly and are tight. If they are not, rewire or tighten as necessary.
3. Disconnect the wires from all the terminals on the starter/generator. Then place the black (–) probe of a multimeter, set to 200 ohms, on the starter/generator housing (scratch through the finish to ensure a good ground). While holding the black (–) probe against the housing, place the red (+) probe (one at a time) on the A1, A2, F1, F2 and DF terminals respectively (**Figure 12-13, Page 12-17**). The readings should be no continuity. If the readings are incorrect, the starter/generator will need to be removed from the vehicle and disassembled by a qualified technician. See **Starter/Generator Removal on page 14-1.**

- An incorrect reading from the A1 or A2 terminal indicates three possible problems: 1) a grounded A1 or A2 terminal, 2) a grounded wire in the brush area, or 3) a grounded armature/commutator.
 - If the F1 or F2 reading is incorrect, it indicates a possible grounded F1 or F2 terminal or a grounded field coil.
 - If the DF reading is incorrect, it indicates a possible grounded DF terminal or a grounded field coil.
4. Disconnect the ground wire from the A2 terminal and the green wire from the A1 terminal on the starter/generator.
 5. Using a multimeter set to 200 ohms, place the red (+) probe on the A1 terminal and the black (-) probe on the A2 terminal. The reading should be continuity. If the reading is incorrect, a possible open or poor contact in a brush assembly and/or open armature windings may be the cause. The starter/generator will need to be removed from the vehicle and disassembled by a qualified technician. **See Starter/Generator Removal on page 14-1.**
 6. With the wires still disconnected, using a multimeter set on 200 ohms, place the red (+) probe on the F1 terminal and the black (-) probe on the F2 terminal. The reading should be between approximately 0.1 and 0.3 ohms. If the reading is incorrect, a possible open field coil or bad connections at terminals may be the cause. The starter/generator will need to be removed from the vehicle and disassembled by a qualified technician. **See Starter/Generator Removal on page 14-1.**
 7. With the wires still disconnected, using a multimeter set to 200 ohms, place the red (+) probe on the DF terminal and the black (-) probe on the F1 terminal. The reading should be between 4.5 and 5.5 ohms. If the reading is incorrect, a possible grounded DF terminal and/or grounded field coil may be the cause. The starter/generator will need to be removed from the vehicle and disassembled by a qualified technician. **See Starter/Generator Removal on page 14-1.**

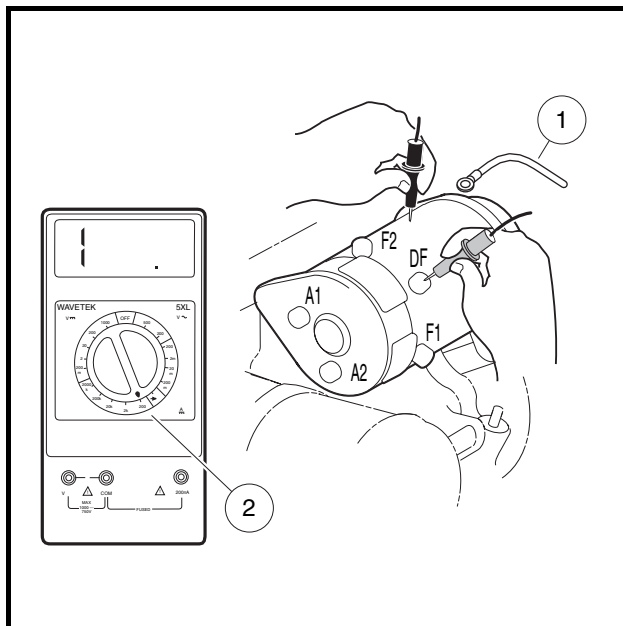

Figure 12-13 Check Starter Terminal Continuity
1. Yellow Wire 2. 200 Ohm Setting

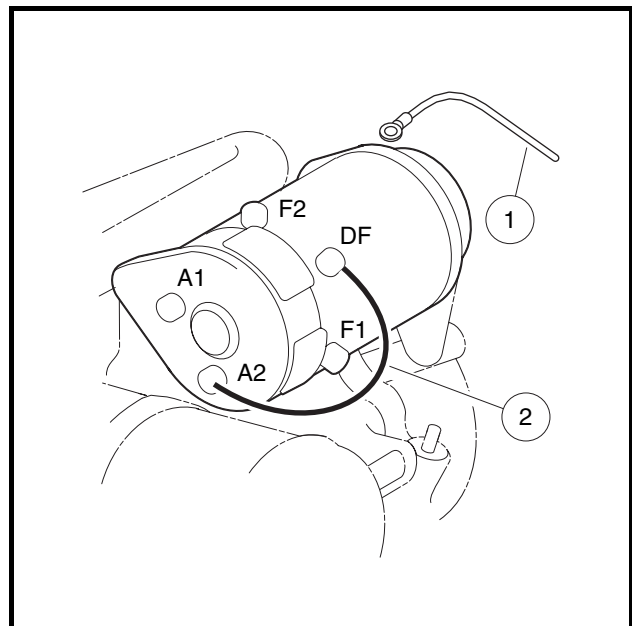

Figure 12-14 Jumper Wire Ground – DF to A2
1. Yellow Wire 2. Jumper Wire

TEST PROCEDURE 9 – WIRE CONTINUITY

See General Warning on page 1-1.

1. Disconnect the battery cables as instructed. See **WARNING “To avoid unintentionally starting...”** in **General Warning on page 1-2**.
2. To test a wire for continuity, disconnect either end from the electrical component it is attached to.
3. Set the multimeter to 200 ohms and place the red (+) probe on the terminal at one end of the wire. Place the black (–) probe on the other terminal end of the wire. The reading should be continuity. If the reading is incorrect, repair or replace the wire.

TEST PROCEDURE 10 – STARTER/GENERATOR (GENERATOR FUNCTION)

See General Warning on page 1-1.

NOTE: Keep the battery connected while performing this test procedure.

1. Place the Forward/Reverse handle in the NEUTRAL position and the neutral lockout switch in the MAINTENANCE position. Chock the wheels.
2. Ensure that the wires are connected correctly and are tight. If they are not, rewire or tighten as necessary.
3. Disconnect the yellow wire from the DF terminal on the starter/generator. Cover the connector on the yellow wire to make sure the yellow wire will not short to ground. Then, using a jumper wire, ground the DF terminal to the A2 terminal (**Figure 12-14, Page 12-17**).
4. Using a multimeter set to 20 volts DC, place the red (+) probe on the positive (+) post of the battery, and place the black (–) probe on the negative (–) post. Start the engine and run it at full governed speed. The reading should show the voltage rising on the meter. If the voltage rises above 15.3 volts DC, test the voltage regulator. See **Test Procedure 11 – Voltage Regulator on page 12-18**. If the voltage does not rise, a tear-down inspection of the starter/generator will be necessary. See **Starter/Generator Removal on page 14-1**.
5. Connect the yellow wire to the DF terminal on the starter/generator.

TEST PROCEDURE 11 – VOLTAGE REGULATOR

See General Warning on page 1-1.

NOTE: Keep the battery connected while performing this test procedure.

1. Place the Forward/Reverse handle in the NEUTRAL position and the neutral lockout switch in the MAINTENANCE position. Chock the wheels.
2. Ensure that the wires are connected correctly and are tight. If they are not, rewire or tighten as necessary.
3. Check the engine RPM setting to ensure that it is adjusted correctly. See **Engine RPM Adjustment on page 16-12**.
4. With the battery in good condition and fully charged, run the engine for several minutes to bring the voltage regulator to operating temperature.
5. Turn the key switch to the OFF position, killing the engine. Using a multimeter set to 20 volts DC, place the red (+) probe on the large post of the solenoid with the red wire from the voltage regulator attached. Place the black (–) probe on the negative (–) battery post (**Figure 12-15, Page 12-19**). Turn the key switch to the ON position. Press the accelerator to start the engine and run it at full governed speed. If

the reading is between 14.7 and 15.3 volts, the regulator is good. If the reading is lower than 14.7 volts but rising steadily, check battery condition. **See Hydrometer Test on page 12-9.** If the reading is lower than 14.7 volts and not rising, and the starter/generator is good; or if the reading is over 15.3 volts and continues to rise, replace voltage regulator. **See Voltage Regulator Removal on page 14-11.**

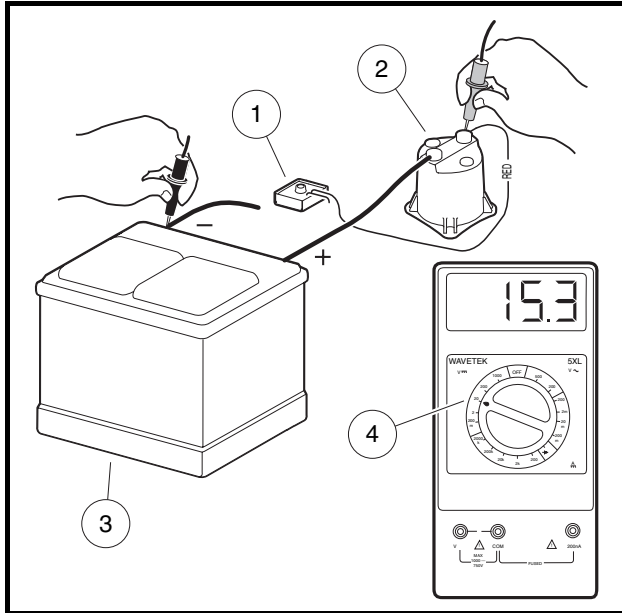

Figure 12-15 Voltage Regulator Test

1. Voltage Regulator 2. Solenoid 3. Battery 4. 20 VDC Setting

TEST PROCEDURE 12 – DISCONNECTED KILL WIRE

See General Warning on page 1-1.

NOTE: Keep the battery connected while performing this test procedure.

1. Place the Forward/Reverse handle in the NEUTRAL position and the neutral lockout switch in the MAINTENANCE position. Chock the wheels.
2. Disconnect the engine kill white/black wire at the bullet connector located next to the RPM limiter (**Figure 12-17, Page 12-20**).
3. Start the engine in a well ventilated area.
 - Turn the key switch to the ON position. Press the accelerator pedal to start the engine.
4. If the engine begins to run, test the engine kill circuit for a shorted wire or other failed components in the engine kill circuit. **See Test Procedure 17 – Key Switch (Engine Kill Circuit) on page 12-27. See following WARNING.**

⚠ WARNING

- When the white/black engine kill wire is disconnected, the engine will not stop running after the accelerator pedal is released. It will be necessary to pull and hold the choke handle until the engine stops running.

5. If the engine does not run, proceed to Test Procedure 13 – Ignition Spark on page 12-20.

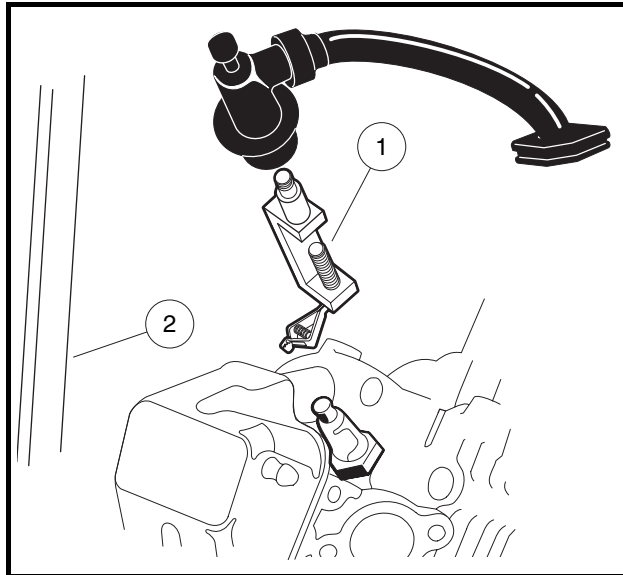

Figure 12-16 Ignition Spark Test

1. Ignition Gap Test Tool 2. Chassis

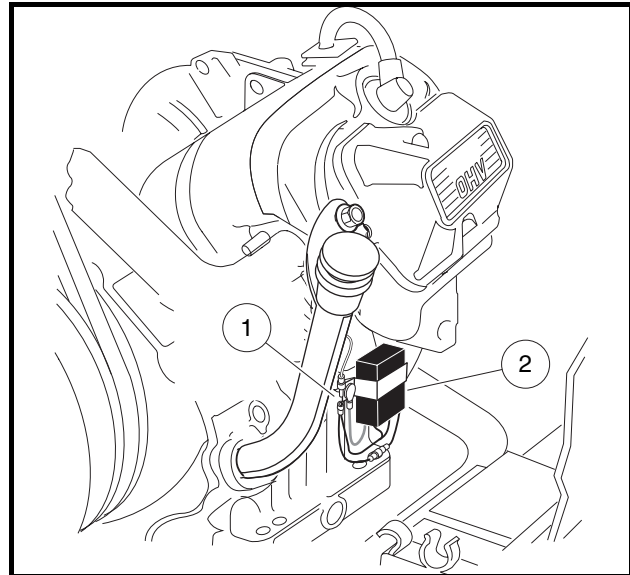

Figure 12-17 White/Black Engine Kill Wire

1. Disconnect White/Black Engine Kill Wire 2. RPM Limiter

TEST PROCEDURE 13 – IGNITION SPARK

See General Warning on page 1-1.

NOTE: Keep the battery connected while performing this test procedure.

- Place the Forward/Reverse handle in the NEUTRAL position and the neutral lockout switch in the MAINTENANCE position. Chock the wheels.
- Remove the plug wire from the spark plug. Using an ignition spark gap test tool (Thexton 404[®] or equivalent), check for correct spark (**Figure 12-16, Page 12-20**).
 - Adjust the tester probes to approximately 18,000 volts (18 Kv) setting (SE – Small Engine Setting on the Thexton 404 tool). Connect the tester to the spark plug wire, and connect the alligator clip to a solid engine ground.
 - Start the engine. There should be a strong blue spark between the probes of the spark gap tester. If there is no spark, or if the spark is a faint yellow or red color, test components of the ignition circuit. **See Test Procedure 15 – Ignition Coil on page 12-21.**
- If the spark gap tester tool indicates a strong blue spark, it is possible the spark plug has failed internally. Check the spark plug gap. The gap should be set at 0.027 to 0.031 of an inch (0.69 to 0.79 mm). If the gap is correct, replace the spark plug with a new part and test the engine for proper operation.

TEST PROCEDURE 14 – RPM LIMITER

See General Warning on page 1-1.

- Disconnect the battery cables as instructed. See **WARNING “To avoid unintentionally starting...”** in **General Warning on page 1-2.**
- Disconnect both of the bullet terminals (**Figure 12-18, Page 12-21**).
- Using a multimeter set to 200 ohms, place the red (+) probe on the brown ground wire and place the black (–) probe on one of the black wire female bullet connectors. The reading should be no continuity. If the reading is not correct, replace the RPM Limiter.

4. This test will find most bad RPM Limiters. Some of them may bench test okay but fail under a load due to heat while operating. Another method of testing is to replace the RPM Limiter and then run the engine. If the engine runs properly, keep the new RPM Limiter in the circuit.

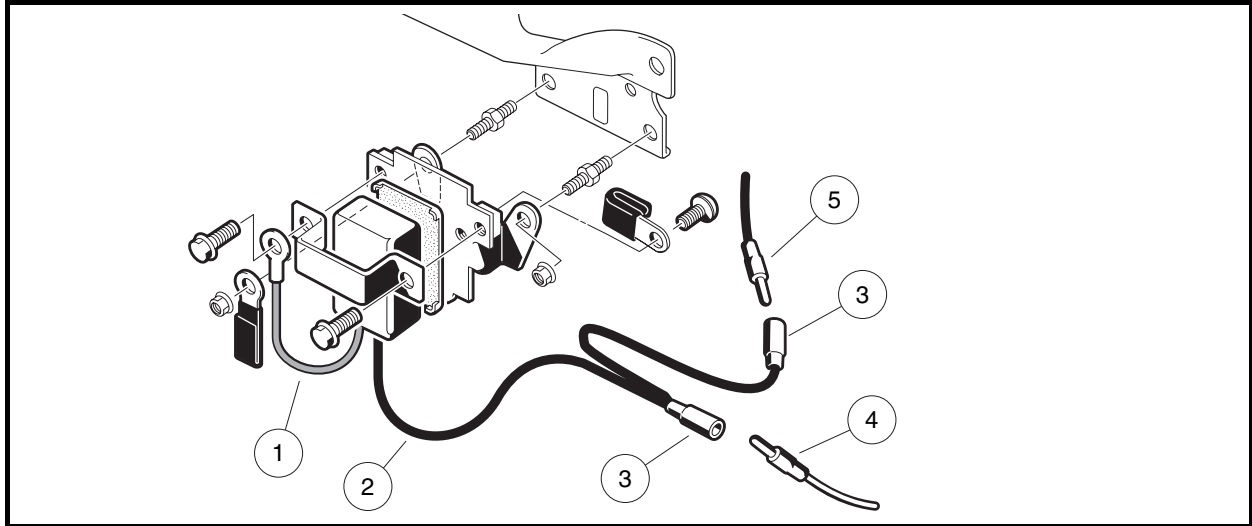

Figure 12-18 RPM Limiter

1. Brown Wire 2. Black Wire 3. Female Bullet Terminal 4. White/Black Kill Circuit Wire 5. Ignition Coil Black Wire

TEST PROCEDURE 15 – IGNITION COIL

See General Warning on page 1-1.

The following test procedures will properly detect a coil that has failed in most cases; however, in rare cases, some ignition coils can fail to operate at normal (warmer) operating temperatures. If the ignition coil has tested okay in the vehicle and on the bench, but fails to operate reliably, replace the coil with a known good coil and operate the engine for several minutes to ensure that the coil functions at normal operating temperature. If the new coil functions properly, keep the new coil in the circuit.

Test Procedure 15A – Ignition Coil – In Vehicle Test

1. Disconnect the battery cables as instructed. See **WARNING “To avoid unintentionally starting...”** in **General Warning on page 1-2.**
2. Using a multimeter set to 200 ohms, measure the primary coil resistance.
 - 2.1. Disconnect both of the bullet terminals at the RPM limiter (**Figure 12-18, Page 12-21**). Place the red (+) probe of the meter on the male bullet terminal of the wire connecting to the ignition coil under the fan housing, and place the black (–) probe on a clean unpainted surface of the engine or frame (**Figure 12-19, Page 12-22**).
 - 2.2. If the resistance is not between 0.6 - 1.7 ohms, bench test the ignition coil. See **Test Procedure 15B – Ignition Coil – Bench Test on page 12-25.**

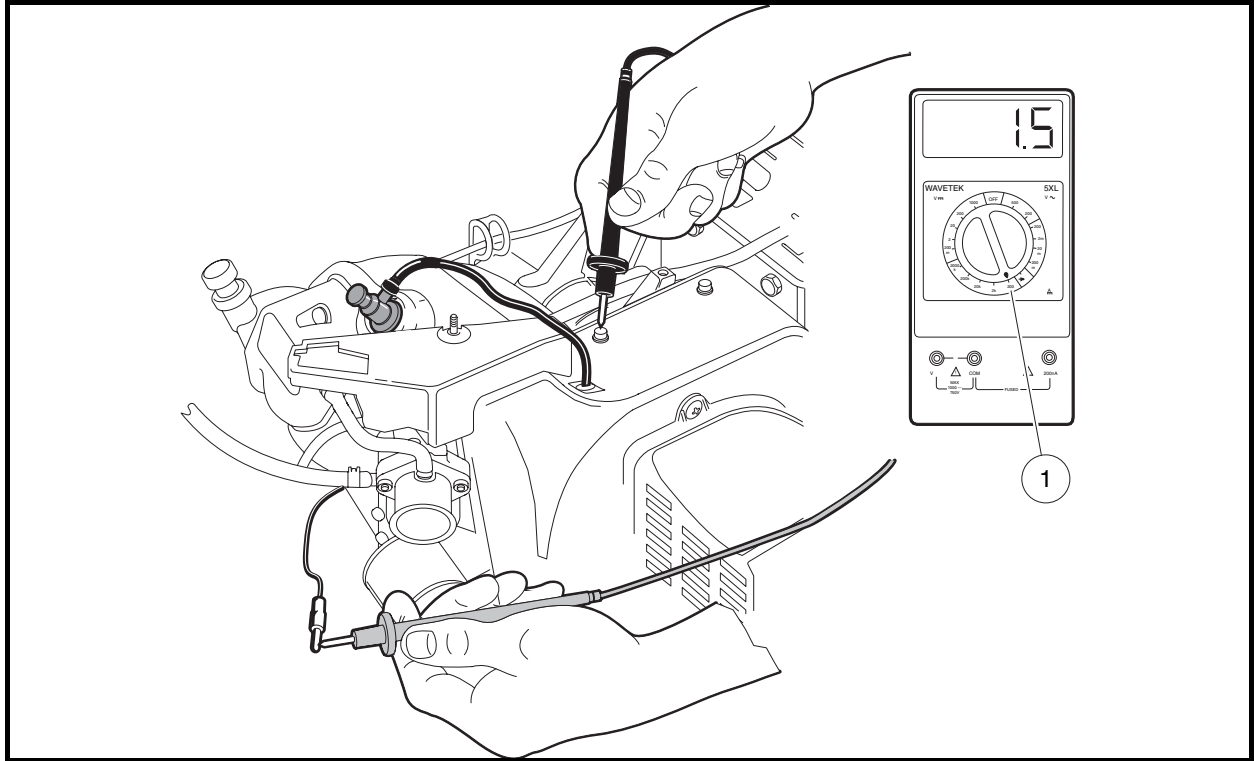

Figure 12-19 Primary Coil Resistance – In Vehicle Test

1. 200 Ohm Setting

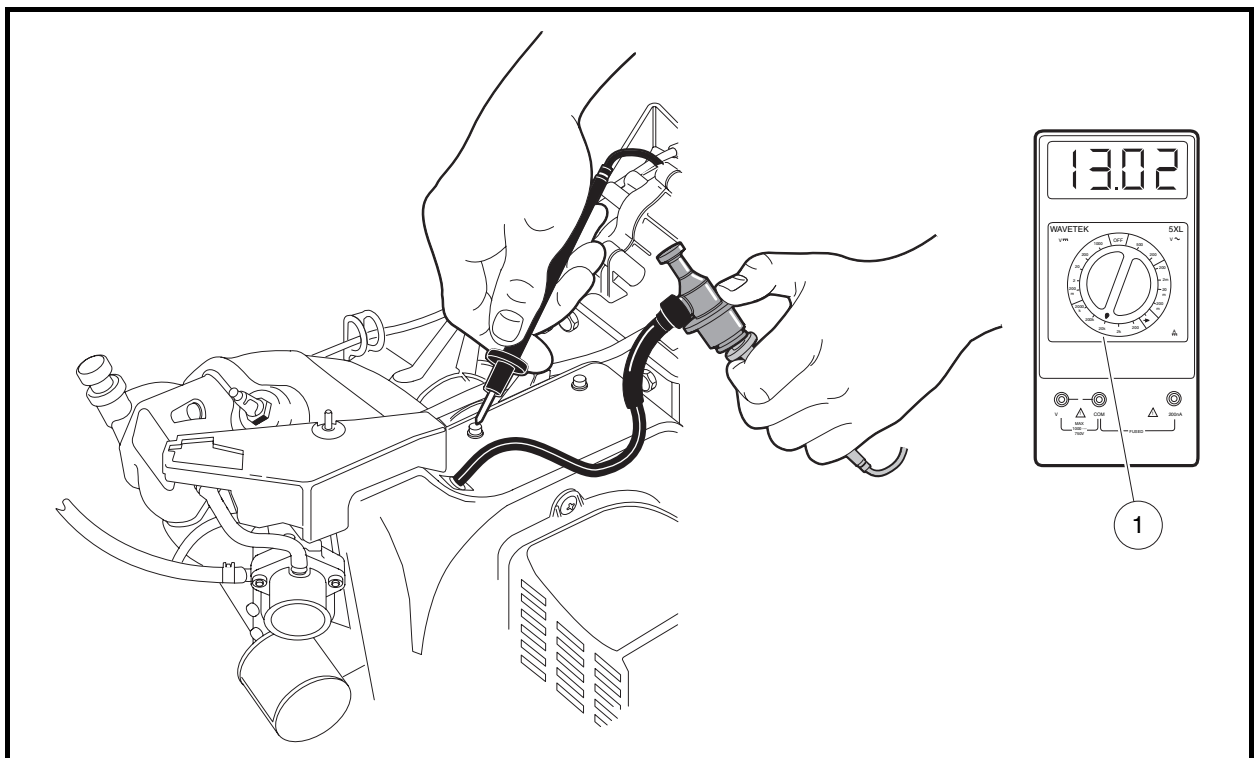

Figure 12-20 Secondary Coil Test – In Vehicle Test

1. 20k Ohm Setting

3. Using a multimeter set to 20k ohms, measure the resistance of the secondary coil and spark plug cap together.
 - 3.1. Place the red (+) probe of the meter into the end of the spark plug cap that normally connects to the spark plug and place the black (-) probe on a clean unpainted surface of the engine or frame (**Figure 12-20, Page 12-22**).
 - 3.2. If the resistance is between 12.0k - 14.0k ohms, the secondary coil and spark plug cap are within acceptable limits; proceed to step 6 on page 12-25. If the resistance is not between 12.0k - 14.0k ohms, the spark plug cap and secondary coil must be tested independently from each other.
4. Test the spark plug cap separately from the secondary coil.
 - 4.1. Remove the rubber gasket (1) on the plug cap (2) by rolling back the gasket onto the spark plug wire (3) (**Figure 12-21, Page 12-23**).
 - 4.2. Remove the cap from the wire by turning the cap counterclockwise three or four revolutions while gently pulling it off the wire (**Figure 12-22, Page 12-23**).

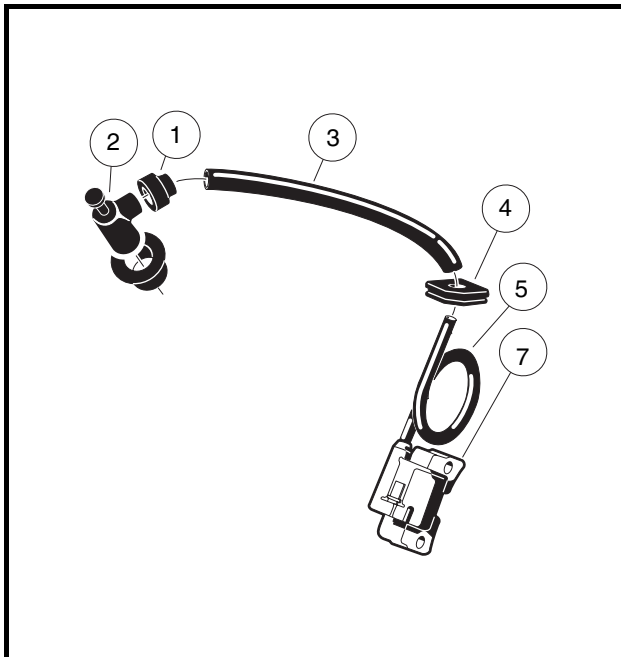

Figure 12-21 Ignition Coil and Cap

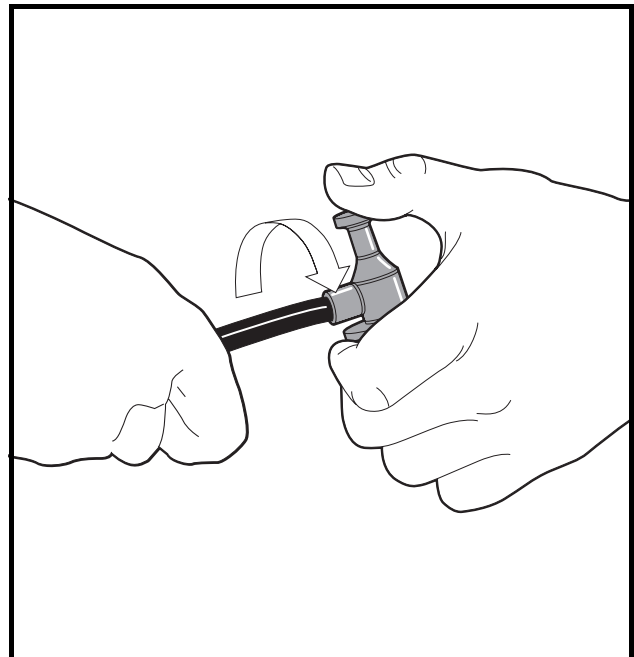

Figure 12-22 Spark Plug Cap Removal

- 4.3. Using a multimeter set to 20k ohms, place the red (+) probe of the multimeter into the end of the spark plug cap that normally connects to the spark plug and place the black (-) probe into the end of the cap with the internal screw (**Figure 12-23, Page 12-24**). If the resistance is not between 4.5k - 6.0k ohms, the cap has failed and must be replaced. Proceed to the next step with the spark plug cap still removed.

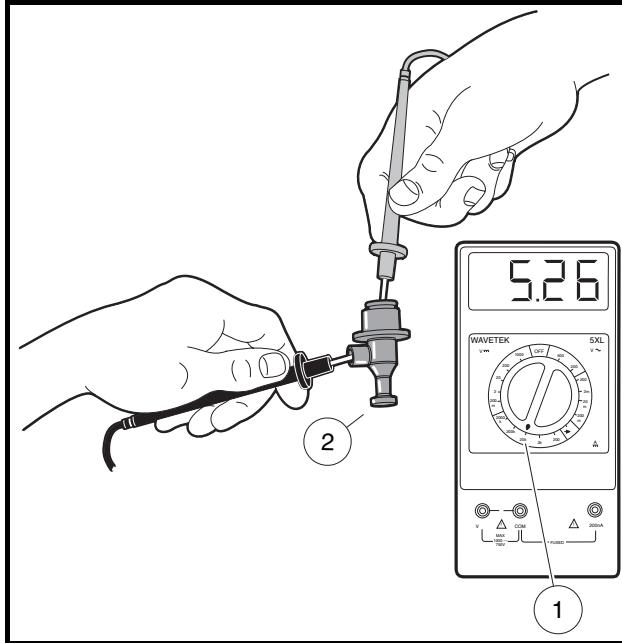

Figure 12-23 Spark Plug Cap Test

1. 20k Ohm Setting 2. Spark Plug Cap

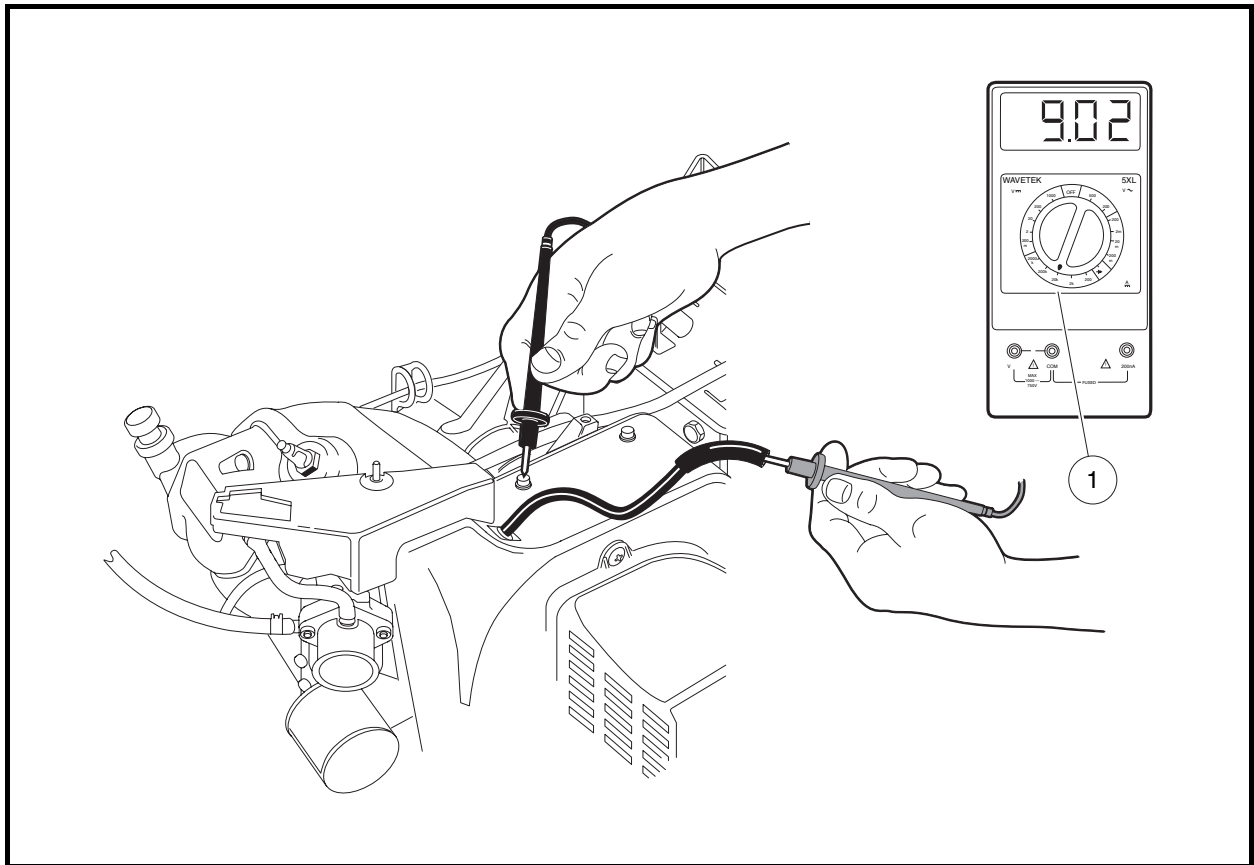

Figure 12-24 Secondary Coil Test Without Cap

1. 20k Ohm Setting

5. Test the secondary coil separately from the spark plug cap.
 - 5.1. Using a multimeter set to 20k ohms, place the red (+) probe of the meter into the end of the spark plug wire and place the black (-) probe on a clean unpainted surface of the engine or frame (**Figure 12-24, Page 12-24**). If the resistance is between 6.0k - 11.0k ohms, the secondary coil is within acceptable limits. If the resistance is not between 6.0k - 11.0k ohms, bench test the ignition coil. **See Test Procedure 15B – Ignition Coil – Bench Test on page 12-25.**
6. If the preceding tests indicate that the ignition coil resistance readings are within acceptable ranges, but the coil fails to function properly, proceed to the following bench test procedures.

Test Procedure 15B – Ignition Coil – Bench Test

1. Remove the coil from the engine. **See Ignition Coil Removal on page 14-23.**
2. Using a multimeter set to 200 ohms, measure the primary coil resistance.
 - 2.1. Place the black (-) probe of the meter on the terminal on the ignition coil (1), and place the red (+) probe on the core (2) (**Figure 12-25, Page 12-25**).

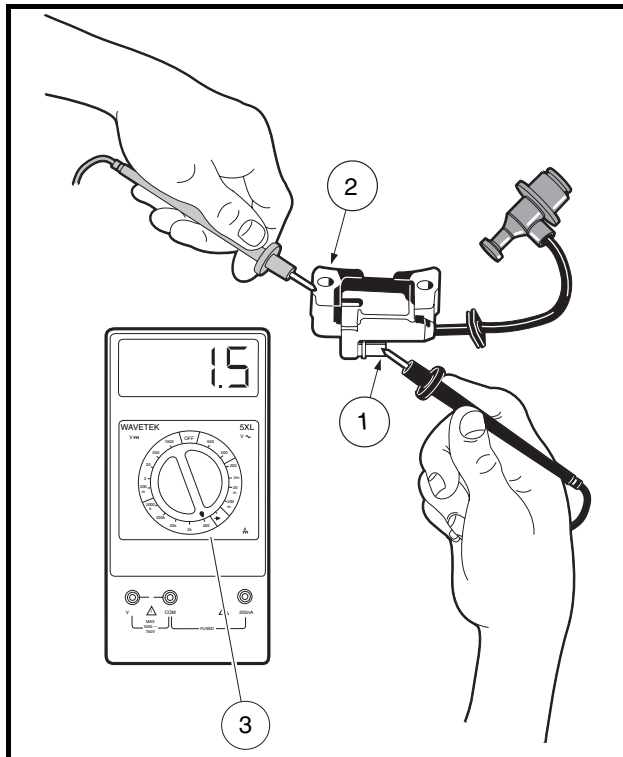

Figure 12-25 Primary Coil Resistance – Bench Test

1. Ignition Coil Terminal 2. Core 3. 200 Ohm Setting

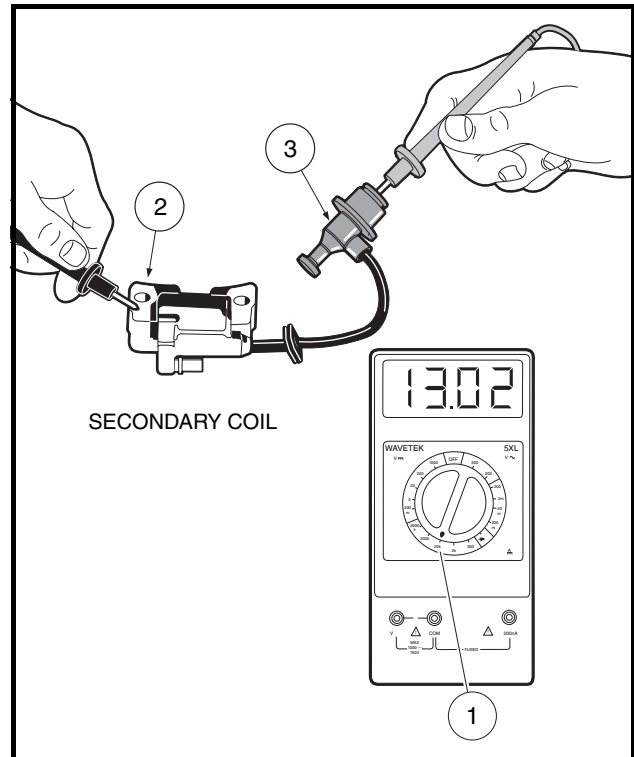

Figure 12-26 Secondary Coil and Cap Resistance – Bench Test

1. 20k Ohm Setting 2. Core 3. Spark Plug Cap

- 2.2. If the resistance is not between 0.6 - 1.7 ohms, replace the ignition coil.
3. Using a multimeter set to 20k ohms, measure the resistance of the secondary coil and spark plug cap together.
 - 3.1. Place the red (+) probe of the meter into the end of the spark plug cap (3) that normally connects to the spark plug and place the black (-) probe on the core (2) (**Figure 12-26, Page 12-25**).

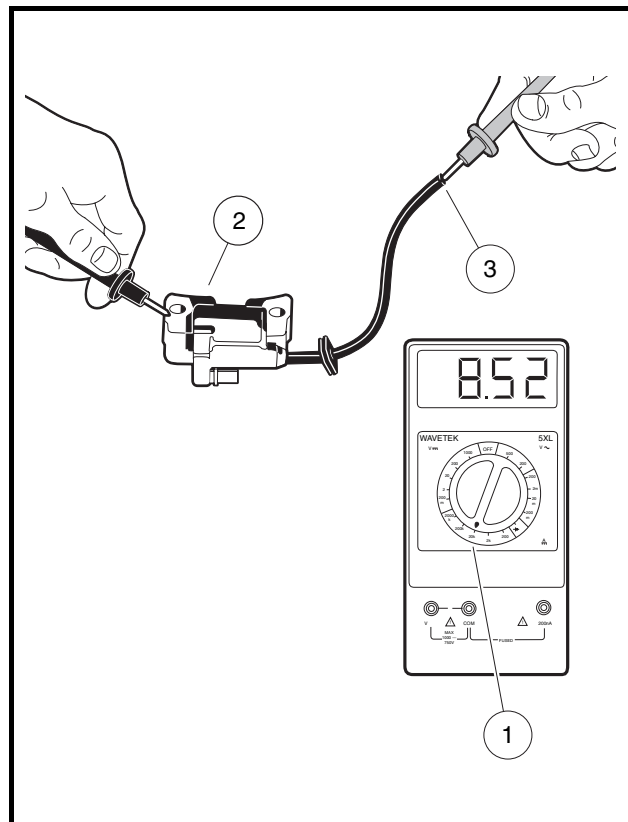

Figure 12-27 Secondary Coil Resistance – Bench Test

1. 20k Ohm Setting 2. Core 3. Spark Plug Wire

- 3.2. If the resistance is between 12.0k - 14.0k ohms, the secondary coil and spark plug cap are within acceptable limits; proceed to step 6 on page 12-26. If the resistance is not between 12.0k - 14.0k ohms, the spark plug cap and secondary coil must be tested independently from each other.
4. If not previously tested, test the spark plug cap separately from the secondary coil.
 - 4.1. Remove the rubber gasket (1) on the plug cap (2) by rolling back the gasket onto the spark plug wire (3) (**Figure 12-21, Page 12-23**).
 - 4.2. Remove the cap from the wire by turning the cap counterclockwise three or four revolutions while gently pulling it off the wire (**Figure 12-22, Page 12-23**).
 - 4.3. Using a multimeter set to 20k ohms, place the red (+) probe of the multimeter into the end of the spark plug cap that normally connects to the spark plug and place the black (-) probe into the end of the cap with the internal screw (**Figure 12-23, Page 12-24**). If the resistance is not between 4.5k - 6.0k ohms, the cap has failed and must be replaced. Proceed to the next step with the spark plug cap still removed.
5. Test the secondary coil separately from the spark plug cap.
 - 5.1. Using a multimeter set to 20k ohms, place the red (+) probe of the meter into the end of the spark plug wire (3) and place the black (-) probe on the core (2) (**Figure 12-27, Page 12-26**). If the resistance is between 6.0k - 11.0k ohms, the secondary coil is within acceptable limits. If the resistance is not between 6.0k - 11.0k ohms, the ignition coil has failed and must be replaced.
6. If the preceding tests indicate that the ignition coil resistance readings are within acceptable ranges, but the coil fails to function properly, replace the ignition coil and cap.

TEST PROCEDURE 16 – KILL LIMIT SWITCH

See General Warning on page 1-1.

The kill limit switch is located inside the electrical component box. The accelerator kill switch is the lower of the two limit switches and has a white/black wire and black wire connected to it.

1. Disconnect the battery cables as instructed. See **WARNING “To avoid unintentionally starting...”** in **General Warning on page 1-2.**
2. Check for proper wiring and tight connections.
3. Disconnect the wires from the limit switch and test the limit switch for continuity.
 - Place the red (+) probe of the multimeter on the common (COM) terminal (white/black wire) of the limit switch. Place the black (–) probe on the normally open (NO) terminal (black wire) of the limit switch. Without the lever pressed, the reading should be no continuity. Press the lever, and the reading should be continuity. If either reading is incorrect, replace the limit switch (**Figure 12-28, Page 12-27**).
4. Connect wires to limit switch and check for tight connections.

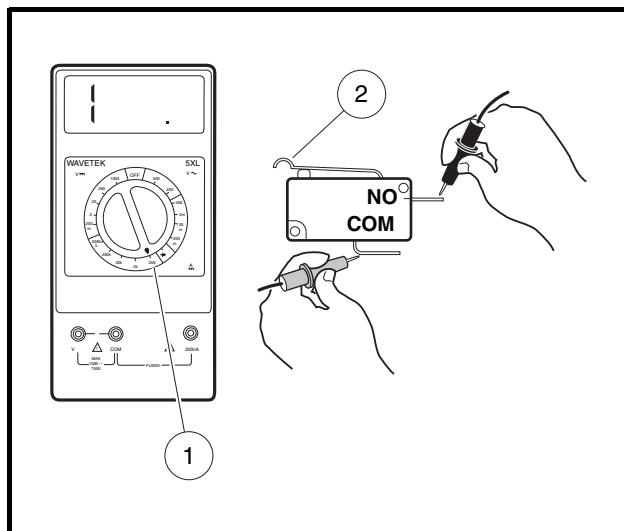

Figure 12-28 Kill Limit Switch Test

1. 200 Ohm Setting 2. Lever Up

TEST PROCEDURE 17 – KEY SWITCH (ENGINE KILL CIRCUIT)

See General Warning on page 1-1.

1. Disconnect the battery cables as instructed. See **WARNING “To avoid unintentionally starting...”** in **General Warning on page 1-2.**
2. Remove the center dash assembly. See **Key Switch Removal on page 14-12.**
3. Disconnect wires from the (+M) and (–M) terminals of the key switch.
4. Place the red (+) probe on the (+M) terminal and the black (–) probe on the (–M) terminal. With the key switch OFF, the reading should be continuity. With the key switch ON, the reading should be no continuity. If either reading is incorrect, replace the key switch (**Figure 12-29, Page 12-28**).
5. Connect wires to the key switch. Make sure wires are connected correctly and are tight. If they are not, rewire or tighten as necessary.
6. Install dash panel in reverse order of removal.

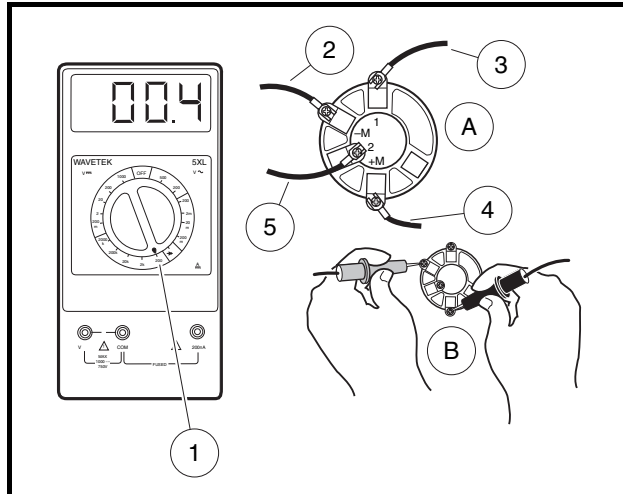

Figure 12-29 Key Switch Test – Engine Kill Circuit

1. 200 Ohm Setting 2. Black/White 3. Blue 4. White/Black 5. Red
A. Key Switch OFF B. Engine Kill Circuit

TEST PROCEDURE 18 – ENGINE KILL WIRE

See General Warning on page 1-1.

1. Disconnect the battery cables as instructed. See **WARNING “To avoid unintentionally starting...”** in **General Warning on page 1-2.**
2. Disconnect white/black wire bullet connector located at the engine RPM limiter (**Figure 12-17, Page 12-20**).
3. Connect red (+) probe of multimeter to the male bullet terminal on the white/black wire and connect the black (–) probe to the vehicle frame.
4. Turn the key switch ON, place the Forward/Reverse handle in FORWARD, and press the accelerator pedal. There should be no continuity. If there is continuity, check for worn insulation on the white/black wire that may be allowing the engine kill wire to ground to the frame.

TEST PROCEDURE 19 – REVERSE BUZZER LIMIT SWITCH

See General Warning on page 1-1.

NOTE: Keep the battery connected while performing this test procedure.

The reverse buzzer limit switch is located on the Forward/Reverse shifter; red/white and orange wires are connected to it.

1. Place the Forward/Reverse handle in the NEUTRAL position and the neutral lockout switch in the MAINTENANCE position. Chock the wheels.
2. Move the Forward/Reverse handle to REVERSE and listen for an audible click from the limit switch. If there is no click, check the switch for proper alignment and switch arm movement.
3. If the switch is being activated but the buzzer does not function, place the red (+) probe of the multimeter on one terminal and the black (–) probe on the other terminal of the limit switch. Without the lever pressed, the reading should be no continuity. Press the lever and the reading should be continuity. If either reading is incorrect, replace limit switch. See **Reverse Buzzer Limit Switch Removal on page 14-19.**

TEST PROCEDURE 20 – REVERSE BUZZER

See General Warning on page 1-1.

The front reverse buzzer is mounted to the center dash assembly under the front body. The rear reverse buzzer is mounted on a bracket at the left rear of the vehicle.

1. Disconnect the battery cables as instructed. See **WARNING “To avoid unintentionally starting...” in General Warning on page 1-2.**
2. To test the front reverse buzzer, remove center dash panel. See **Key Switch Removal on page 14-12.**
3. Check for proper wiring and tight connections. Using a multimeter, individually check for continuity through each wire that connects to the reverse buzzer. See **Wiring Diagram on page 12-6.** If the buzzer will not function when properly wired, replace the buzzer.

TEST PROCEDURE 21 – LOW OIL WARNING LIGHT

See General Warning on page 1-1.

1. Disconnect the battery cables as instructed. See **WARNING “To avoid unintentionally starting...” in General Warning on page 1-2.**
2. Remove the center dash assembly. See **Key Switch Removal on page 14-12.**
3. Ensure that the wires are connected correctly and are tight. If they are not, rewire or tighten as necessary. See **Wiring Diagram beginning on page 12-6.**
4. Disconnect the yellow wire (to the oil level sensor) from the terminal on the low oil warning light. Using an alligator clip jumper wire, connect the low oil warning light terminal to the vehicle frame. Connect the red (+) battery cable to the positive (+) battery post, then attach the black (–) cable to the negative (–) battery post.
5. Turn the key switch ON. The low oil warning light should illuminate. If it does not, check continuity of the yellow wire that connects the key switch to the low oil warning light. If there is no continuity in the wire, replace the wire. Then test the key switch. See **Test Procedure 4 – Key Switch (Starter Circuit) on page 12-13.** If the yellow wire and the key switch test okay, then replace the low oil warning light.

TEST PROCEDURE 22 – OIL LEVEL SENSOR

See General Warning on page 1-1.

NOTE: Keep the battery connected while performing this test procedure.

1. Place the Forward/Reverse handle in the NEUTRAL position, the neutral lockout switch in the MAINTENANCE position, turn the key switch to the OFF position, disconnect the spark plug wire, and chock the wheels.
2. Ensure that the low oil warning light and all connecting wires are functioning correctly. See **Test Procedure 21 – Low Oil Warning Light on page 12-29.**
3. Drain the engine oil into an approved container and properly dispose of used oil.
4. Turn the key switch ON, closing the circuit. The low oil warning light should illuminate. If the low oil warning light does not illuminate, the oil level sensor needs to be replaced. See **Oil Level Sensor Removal on page 15-5.**
5. Install a new oil filter and fill the engine with new oil before returning the vehicle to service. See **Engine Oil – Gasoline Vehicles on page 10-6.**

TEST PROCEDURE 23 – NEUTRAL LOCKOUT SWITCH

See General Warning on page 1-1.

1. Remove the wires from the switch (**Figure 12-30, Page 12-30**).
2. With switch in position 1:
 - 2.1. Check for no continuity between terminals T1 and T2.
 - 2.2. Check for continuity between terminals T2 and T3.
3. With switch in position 2:
 - 3.1. Check for no continuity between terminals T2 and T3.
 - 3.2. Check for continuity between terminals T1 and T2.

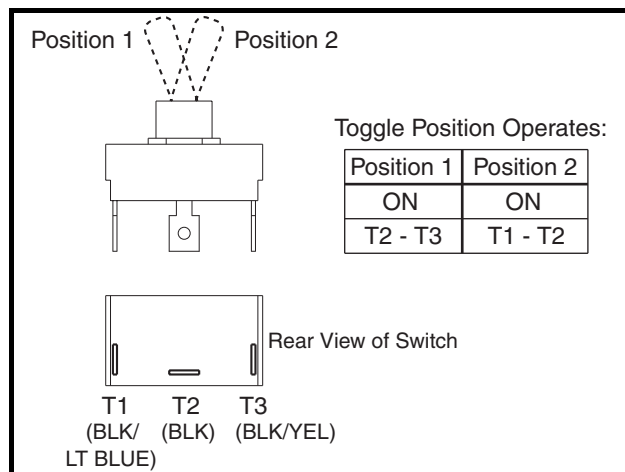

Figure 12-30 Neutral Lockout Switch Test – for Pedal-Start Vehicles

4. If switch:
 - 4.1. does not work as stated in previous steps, replace switch.
 - 4.2. does work as stated and the MAINTENANCE/OPERATE modes still do not work:
 - Check the fuse.
 - Check the limit switches.
 - Check continuity of the wires involved.

TEST PROCEDURE 24 – BATTERY TEST (UNDER LOAD)

See General Warning on page 1-1.

NOTE: Keep the battery connected while performing this test procedure.

1. Place the Forward/Reverse handle in the NEUTRAL position and the neutral lockout switch in the MAINTENANCE position. Chock the wheels.
2. Set a multimeter to 20 volts DC and place the red (+) probe on the F2 (white wire) terminal on the starter/generator. Place the black (-) probe on the negative (-) battery post.
3. Turn the key switch to the ON position, leave the Forward/Reverse shifter in the NEUTRAL position and press the accelerator pedal (with the accelerator pedal pressed, the battery is under load).
 - 3.1. If the voltage reading is over 9.6 volts, with an electrolyte temperature of 70 °F (21 °C), check the

starter/generator. **See following NOTE.**

NOTE: The voltage reading listed is for electrolyte at 70 °F (21 °C). At lower electrolyte temperatures the voltage reading will be lower.

- 3.2. If the reading is below 9.6 volts, with an electrolyte temperature of 70 °F (21 °C), check the battery. **See Test Procedure 1 – Battery on page 12-9.**
- 3.3. If the reading is zero, there may be no continuity across the large posts of the solenoid. **See Test Procedure 6 – Solenoid on page 12-15.**
4. If all of the test results are good and the voltage reading is zero, there may be a broken or damaged 6-gauge white wire from the solenoid to the starter/generator. **See Test Procedure 8 – Starter/Generator (Starter Function) on page 12-16.**

TEST PROCEDURE 25 – FUEL LEVEL SENDING UNIT

See General Warning on page 1-1.

⚠ WARNING

- To avoid the possibility of fire or explosion, make sure the fuel tank cap is securely in place while performing this test procedure.

1. Disconnect the battery cables as instructed. **See WARNING “To avoid unintentionally starting...” in General Warning on page 1-2.**
2. Disconnect the orange wire from the center post of the fuel level sending unit.
3. With a multimeter set to 2k ohms, place the red (+) probe of the multimeter on the center post of the sending unit. Place the black (–) probe on the ground connection of the sending unit (**Figure 12-31, Page 12-32**).
4. The following resistance readings (in ohms) should be obtained depending on the position of the float inside the fuel tank. The resistance reading will vary according to the exact position of the float. The chart below may be used as a guideline to determine if the fuel level sending unit is operating correctly. Make sure the float is at the surface of the fuel in the tank.

FLOAT POSITION	RESISTANCE READING	FUEL GAUGE READINGS
Lower position (tank empty)	240 ± 20 ohms	Empty
Center position (tank half full)	120 ± 20 ohms	Half full
Upper position (tank full)	60 ± 20 ohms	Full

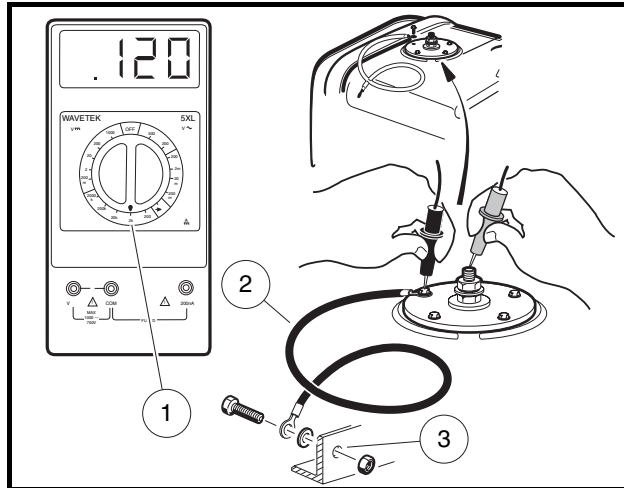

Figure 12-31 Fuel Level Sending Unit Test

1. 2k Ohm Setting 2. Black Wire 3. Ground

5. If the readings are within the specifications listed above, the fuel level sending unit is working properly. If the readings are incorrect, the fuel level sending unit has failed and the fuel tank must be replaced. **See Fuel Tank Removal on page 16-22.**
6. If the readings are correct and the fuel gauge does not function correctly, check the continuity of the orange wire from the fuel level sending unit to the fuel gauge/hour meter. Leave the battery disconnected while checking continuity. Also check the continuity of the blue wire from the fuel gauge/hour meter to the key switch, and the black ground wires at the fuel level sending unit and at the fuel gauge/hour meter. **See Fuel Gauge/Hour Meter Removal on page 14-21.**
7. If the readings are correct according to the position of the float, but give an incorrect reading on the fuel gauge/hour meter, test the fuel gauge/hour meter. **See Test Procedure 26 – Fuel Gauge on page 12-32.**

TEST PROCEDURE 26 – FUEL GAUGE

See General Warning on page 1-1.

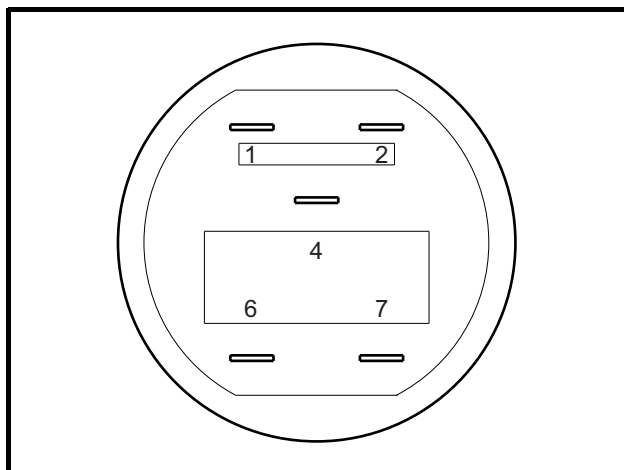

Figure 12-32 Fuel Gauge/Hour Meter Terminals

1. Black(Jumper Wire From 6) 2. Blue 4. Orange 6. Black 7. White

NOTE: Keep the battery connected during this test procedure.

1. Turn the key switch OFF and remove the key. Place the Forward/Reverse handle in NEUTRAL. Chock the wheels.
2. Remove the instrument panel to gain access to the back of the fuel gauge/hour meter. **See Key Switch Removal, Section 13, Page 13-14.**
3. Place a sheet of insulating material between the front frame and the electrical connections on the rear of the instrument panel to prevent contact between the two.
4. Disconnect the orange wire from the fuel gauge/hour meter.
5. Set a multimeter to 20 volts DC and place the red (+) probe on the positive (+) post of the battery. Place the black (-) probe on the negative (-) post of the battery. Record the voltage reading.
6. Set a multimeter to 20 volts DC and place the red (+) probe on the (2) terminal of the fuel gauge/hour meter where the blue wire is connected. Place the black (-) probe on the (1) terminal of the fuel gauge/hour meter with the black wire (**Figure 12-33, Page 12-33**).
7. Turn the key switch ON. The voltage reading should be the same as the battery voltage reading recorded earlier. If not, check the continuity of the blue and black wires (**Figure 12-33, Page 12-33**).
8. The orange wire should remain disconnected for this step. Place the black probe of the multimeter on the (1) terminal of the fuel gauge/hour meter and place the red (+) probe on the (4) terminal of the fuel gauge/hour meter (**Figure 12-34, Page 12-33**). The voltage reading should be approximately 4.94 volts. If the reading is incorrect, replace the fuel gauge/hour meter.

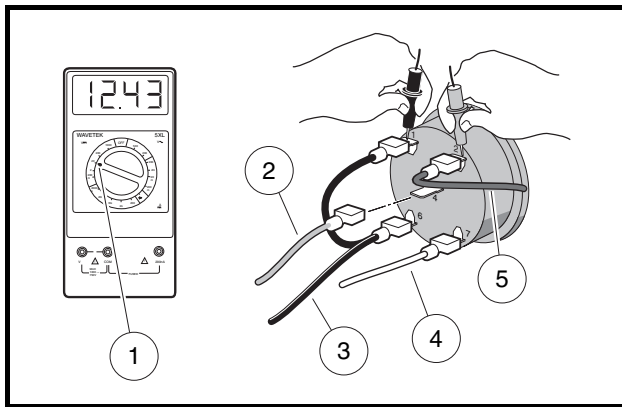

Figure 12-33 Fuel Gauge Voltage Test - Terminal 2

1. 20 VDC Setting 2. Orange 3. Black 4. White 5. Blue

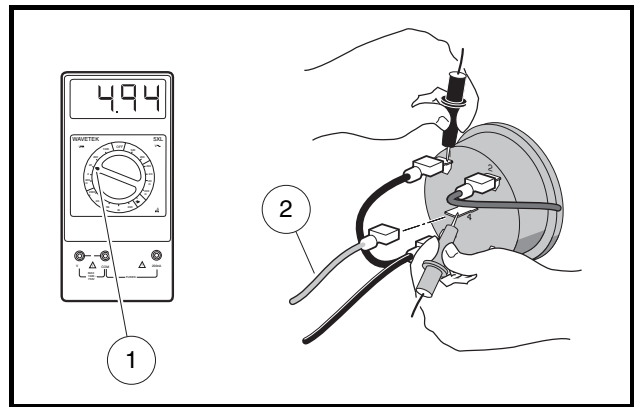

Figure 12-34 Fuel Gauge Voltage Test - Terminal 4

1. 20 VDC Setting 2. Orange

TEST PROCEDURE 27 – HOUR METER

See General Warning on page 1-1.

NOTE: Keep the battery connected during this test procedure.

1. Place the Forward/Reverse handle in the NEUTRAL position and the neutral lockout switch in the MAINTENANCE position. Chock the wheels.
2. With the key switch OFF, check the hour meter display. It is powered by an internal battery and should always be on, even with the engine off and the key removed.
3. Start the engine and let it idle. **See following DANGER.**

⚠ DANGER

- **Do not operate vehicle in an enclosed area without proper ventilation. The engine produces carbon monoxide, which is an odorless, deadly poison.**
4. With engine idling, the "hour glass" icon should flash. If not, check the low oil warning light and the oil pressure switch. **See following NOTE. See also Test Procedure 21 – Low Oil Warning Light on page 12-29.**

NOTE: *The hour meter is designed to record actual engine running time and will not start adding increments until the engine is running and the oil pressure switch has opened.*

5. If the hour meter still does not function after the low oil warning light, oil pressure switch, and all of the appropriate wires have been checked for continuity, replace the fuel gauge/hour meter.

TEST PROCEDURE 28 – LIGHT SWITCH

See General Warning on page 1-1.

1. Turn the key switch OFF and remove the key. Place the Forward/Reverse handle in the NEUTRAL position. Chock the wheels.
2. Disconnect the battery cables as instructed. **See WARNING “To avoid unintentionally starting...” in General Warning on page 1-2.**
3. Remove the instrument panel. **See Key Switch Removal, Section 13, Page 13-14.**
4. Using a multimeter set on 20 volts DC, place alligator clips on the multimeter probes. Connect the red (+) probe to the light switch terminal with the blue wire connected to it (**Figure 12-35, Page 12-35**).
5. Connect the battery cables, positive (+) cable first.
6. Connect the black (–) probe of the multimeter to the negative (–) post of the battery.
7. With the light switch in the OFF position, the reading should be zero volts. With the light in the ON position, the reading should be between 11 and 12.5 volts. If there is no voltage reading, check continuity of the 10-gauge red wire from the fuse block to the solenoid. Check continuity of the 14-gauge yellow wire from the light switch to the fuse block. Check the fuse. **See Test Procedure 2 – Fuse on page 12-12.** If the voltage limiter is functioning correctly, the wires and fuse show continuity and the readings are still incorrect, replace the switch. **See Light Switch Removal, Section 13, Page 13-29.**

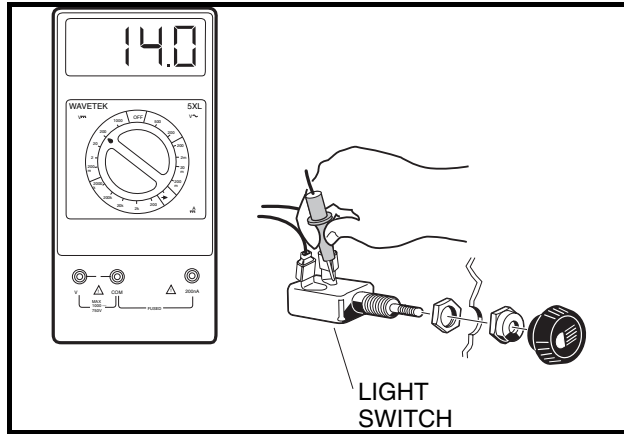

Figure 12-35 Light Switch Test

TEST PROCEDURE 29 – VOLTAGE LIMITER

See General Warning on page 1-1.

1. Turn the key switch OFF and remove the key. Place the Forward/Reverse handle in the NEUTRAL position. Chock the wheels.
2. Disconnect the battery cables as instructed. See WARNING “To avoid unintentionally starting...” in General Warning on page 1-2.
3. Remove the instrument panel. See Key Switch Removal, Section 13, Page 13-14.
4. Using a multimeter set on 20 volts DC, connect the red (+) probe to the light switch terminal with the yellow wire (Figure 12-36, Page 12-36).
5. Loosen the black wire connector (on the end of the long black wire) at the voltage limiter just enough to maintain the connection and yet expose part of the metal terminal in the connector. Place black (–) probe on the connector (Figure 12-36, Page 12-36).
6. Connect the battery, positive (+) cable first.
7. Pull the light switch to the ON position. The reading should be 11-12 volts. If there is no voltage reading, check continuity of the 16-gauge black wire from the headlight to the voltage limiter. Check continuity of the 16-gauge black wire from voltage limiter to the vehicle frame. If the wires show continuity and the readings are still incorrect, replace the voltage limiter. See Voltage Limiter Removal, Section 13, Page 13-28.
8. With the Forward/Reverse handle in the NEUTRAL position and the wheels chocked, start the engine and press the accelerator pedal to the floor.
9. Push the light switch to the OFF position. The reading should be 14.7-15.3 volts.
10. Pull the light switch to the ON position. The reading should be 11-13 volts. If the reading does not drop from 14.5-15.5 volts to 11-13 volts, replace the voltage limiter.

TEST PROCEDURE 30 – VOLTAGE AT HEADLIGHT SOCKET

See General Warning on page 1-1.

NOTE: Keep the battery connected while performing this test procedure.

1. Turn the key switch OFF and remove the key. Place the Forward/Reverse handle in the NEUTRAL position. Chock the wheels.

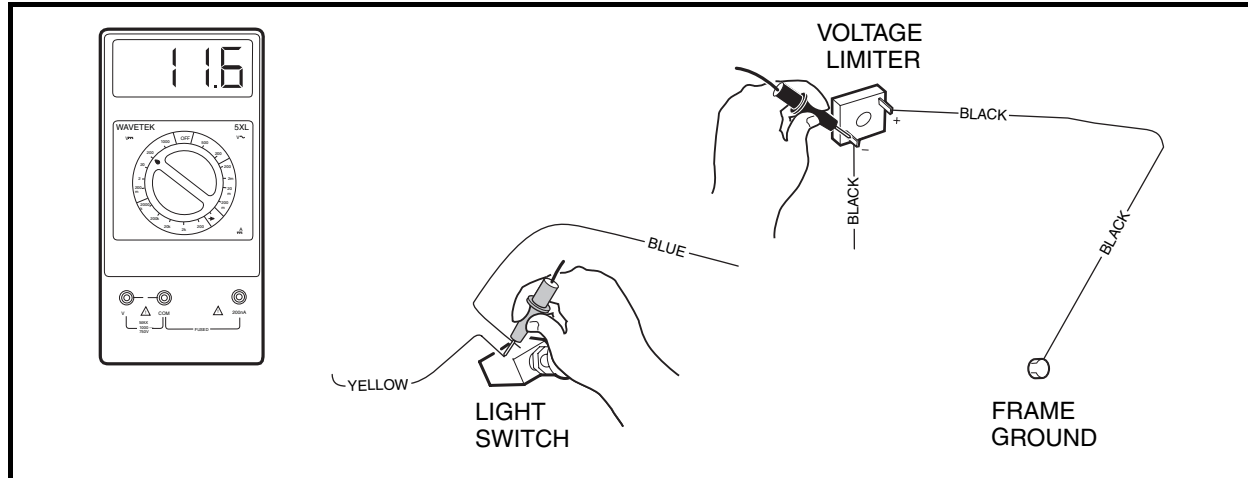

Figure 12-36 Voltage Limiter Circuit Test

2. Inspect wires at light bulb socket. Make sure wires are securely fastened to the contacts inside socket.
3. Remove the wire harness from the headlight (**Figure 12-37, Page 12-36**).
4. Using a multimeter set to 20 volts DC, place the black (-) probe of multimeter into the black wire terminal of the wire harness. Place the red (+) probe into the blue wire terminal.
5. Pull the light switch to the ON position. If the multimeter reads approximately 12 volts, replace the bulb.
6. If there is no voltage reading at the wire harness, check continuity of the 16-gauge blue wire from the headlight to the light switch. Using a multimeter set to 20 volts DC, attach using an alligator clip, the black (-) probe of multimeter onto the negative battery terminal and place the red (+) probe into the blue wire terminal of the wire harness. If multimeter reading is approximately 12 volts, the blue wire has continuity.
7. Check continuity of the 16-gauge black wire from the headlight to the ground terminal. Using a multimeter set to 20 volts DC, place the black (-) probe of multimeter into the black wire terminal of the wire harness and attach using an alligator clip, the red (+) probe onto the positive battery terminal. If the multimeter reading is approximately 12 volts, the black wire has continuity.

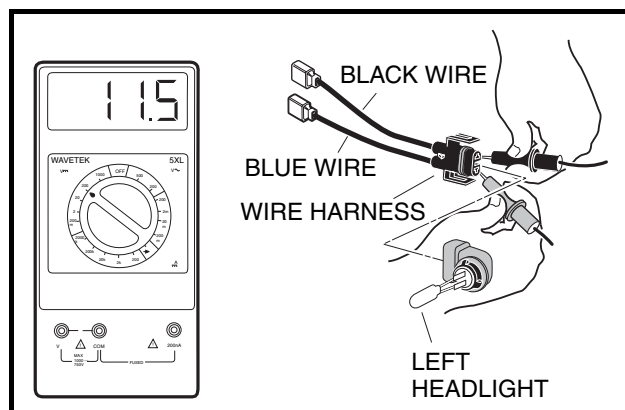

Figure 12-37 Check Voltage to Headlight Socket

SECTION 13 – ELECTRICAL COMPONENTS: 800 AND 810 GASOLINE VEHICLES

⚠ DANGER

- See General Warning on page 1-1.

⚠ WARNING

- See General Warning on page 1-1.

STARTER/GENERATOR

See General Warning on page 1-1.

Testing the Starter/Generator

See Test Procedure 8, Section 11, Page 11-17. Also See Test Procedure 11, Section 11, Page 11-20.

Starter/Generator Removal

1. Make sure the key switch is OFF and the Forward/Reverse handle is in the NEUTRAL position. Chock the wheels.
2. Disconnect the battery cables as instructed. **See WARNING “To avoid unintentionally starting...” in General Warning on page 1-2.**
3. Disconnect the wires from the starter/generator (1). Mark wires before disconnecting. Loosen the pivot nuts (7) and bolts (5) (**Figure 13-1, Page 13-2**).
4. Remove the mounting/adjustment nut (12), washer (9) and bolt (11). Lower the starter/generator and slip the belt (4) off the pulley (10).
5. Support the starter/generator so that when the pivot bolts are removed the starter/generator will not fall to the ground. Remove the two pivot nuts (7) and bolts (5) from the mounting bracket.
6. Remove the starter/generator.

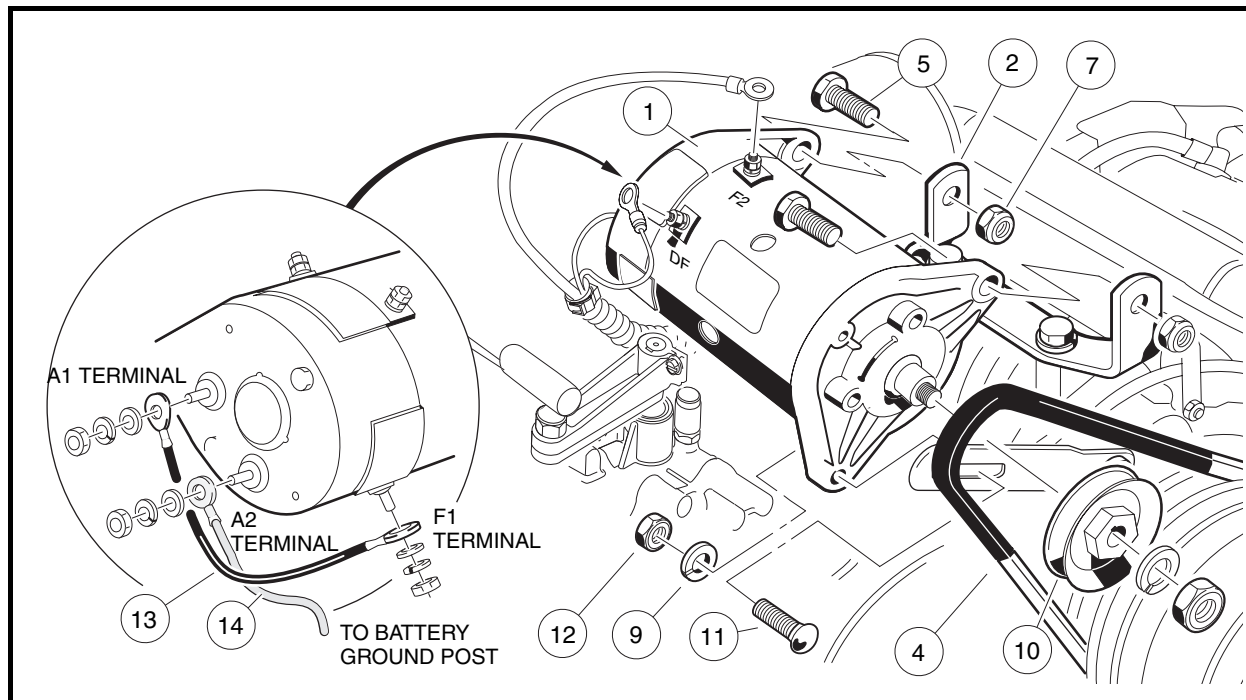

Figure 13-1 Starter/Generator Removal

Disassembly of the Starter/Generator to Service the Brushes

1. Remove the two bolts (20) and pull commutator end cover (23) free of starter/generator housing (24) (Figure 13-2, Page 13-2). See following NOTE.

NOTE: Brushes must be removed to avoid damage from commutator removal. Lift the brush springs out of the notches in the brushes and pull the brushes back from the center of the commutator end cover. The springs will help prevent them from sliding back towards the center (Figure 13-6, Page 13-4).

2. Remove brush covers (29 and 30), screws (25), lockwashers (26), brush springs (28) and brushes (27) (Figure 13-3, Page 13-2). See following NOTE.

NOTE: To clean and inspect the armature/commutator and the bearings, see *Disassembly of the Starter/Generator to Service the Armature/Commutator* on page 13-4.

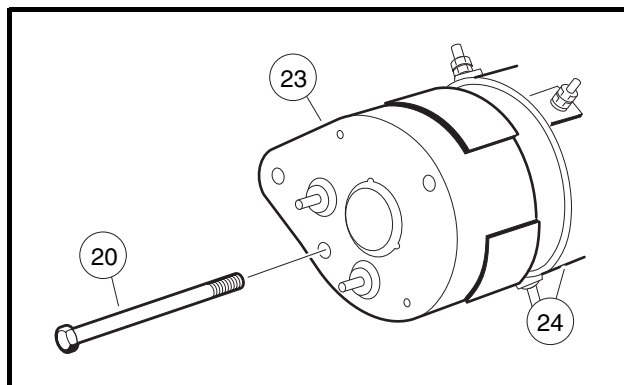

Figure 13-2 Commutator End Cover

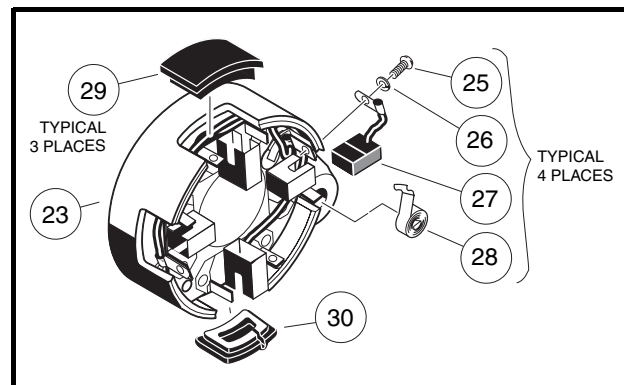

Figure 13-3 Brush Covers and Brushes

Brush Inspection and Replacement

1. Visually inspect brushes. Replace brushes that are cracked or severely chipped.
2. Check the wear line on the side of the brush. If the end of the brush is within 1/16-inch (1.6 mm) of the wear line, replace all four brushes (**Figure 13-4, Page 13-3**).

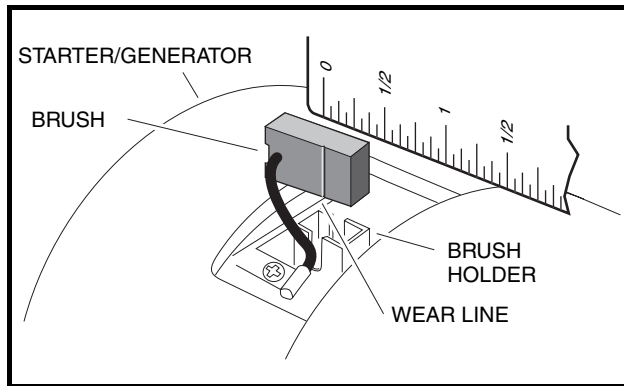

Figure 13-4 Inspect Brushes

Brush Spring Inspection and Replacement

1. Visually inspect springs. Replace all four springs if any spring is discolored from heat (straw or bluish in color).
2. Install the four brushes (27) into their holders and insert the four brush springs (28) (**Figure 13-3, Page 13-2**). Using a spring scale, test brush spring tension. If any spring has a tension less than 24 ounces (6.67 N), replace all four springs (**Figure 13-5, Page 13-3**). See following CAUTION.

CAUTION

- When checking brush spring tension, do not push springs beyond the point they would normally be if there were new brushes installed. Exerting excessive force or pushing brush springs beyond their normal maximum extension point will damage springs.

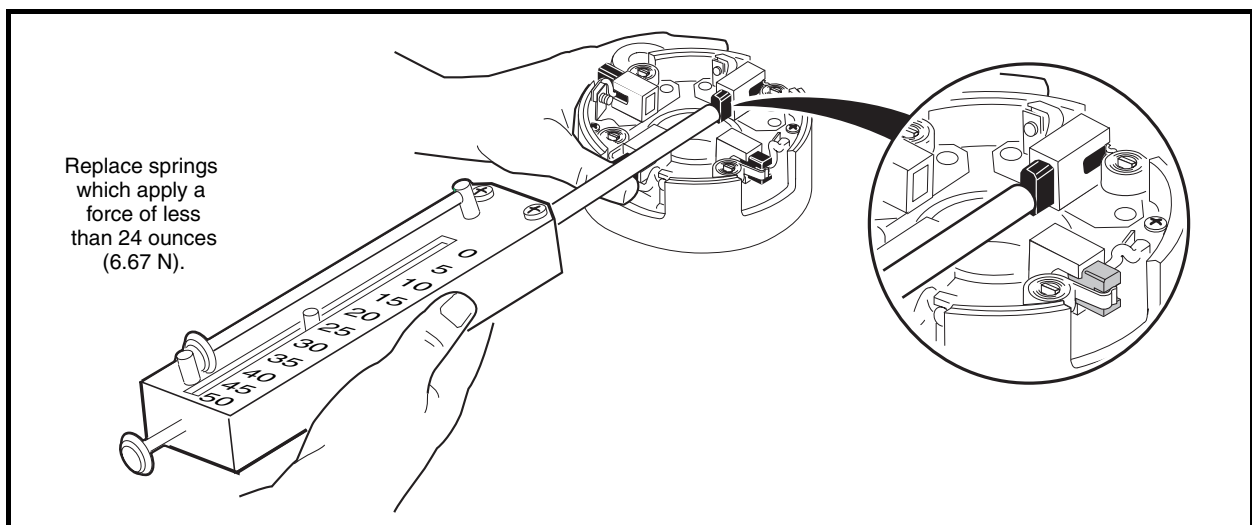

Figure 13-5 Brush Spring Tension Test

Starter/Generator Assembly

1. Connect the brush wires to the holders using four lockwashers (26) and four screws (25). Make sure the crossover leads are also connected. Tighten the screws to 31 in-lb (3.5 N·m) (**Figure 13-3, Page 13-2**).
2. Install the commutator. Lift the brush springs out of the notches in the brushes and pull the brushes back from the center of the commutator end cover to avoid interference. The springs will rest on the sides of the brushes and help prevent them from sliding to the center (**Figure 13-6, Page 13-4**).
3. Install the commutator end cover (23) onto the armature shaft. Align the locating pin and hole in the cover. Install two M6 x 180 mm bolts (20) and tighten to 100 in-lb (11.3 N·m) (**Figure 13-2, Page 13-2**).
4. Push the brushes down into the holders. Place springs into the notches in the brushes. Install the brush cover (30) that has the drain hole in it next to the A2 terminal. Install the remaining three brush covers (29) onto the openings in the commutator end cover (23) (**Figure 13-3, Page 13-2**).

Disassembly of the Starter/Generator to Service the Armature/Commutator

1. Remove the two bolts (20), and pull commutator end cover (23) free of the starter/generator housing (24) (**Figure 13-2, Page 13-2**). See following NOTE.

NOTE: Brushes must be removed to avoid damaged from commutator removal. Lift the brush springs out of the notches in the brushes and pull the brushes back from the center of the commutator and cover. The springs will help prevent them from sliding back towards the center (**Figure 13-6, Page 13-4**).

2. Remove nut (41), lockwasher (40), pulley (39), shaft key (34), spacer (37) and bearing retainer screws (43) and separate armature (33) from output end cover (36) (**Figure 13-7, Page 13-5**).

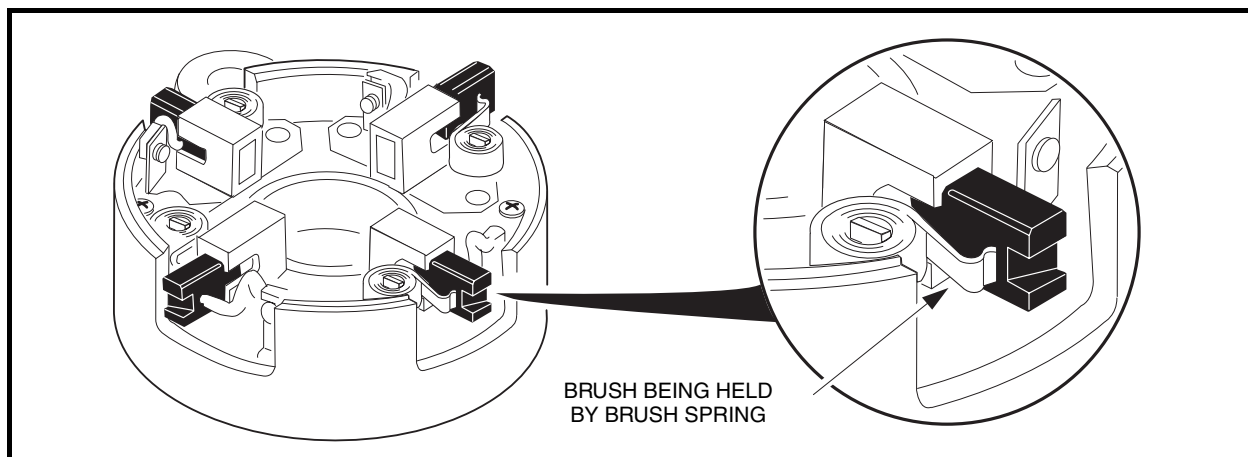

Figure 13-6 Pull Brushes Away From Center of the Commutator End Cover

Bearing Cleaning and Inspection

1. Wipe the carbon dust from the two bearings. Inspect bearings by spinning them by hand and checking for both axial (A) and radial (B) play (**Figure 13-8, Page 13-5**).
2. Replace the bearing if it is noisy, does not spin smoothly or has excessive play. Replace if rusted, worn, cracked, or if there is an abnormal color change in the metal of the bearing. Replace if there is extensive wear or pitting on the balls or rolling surfaces. Do not remove bearings unless they are to be replaced.

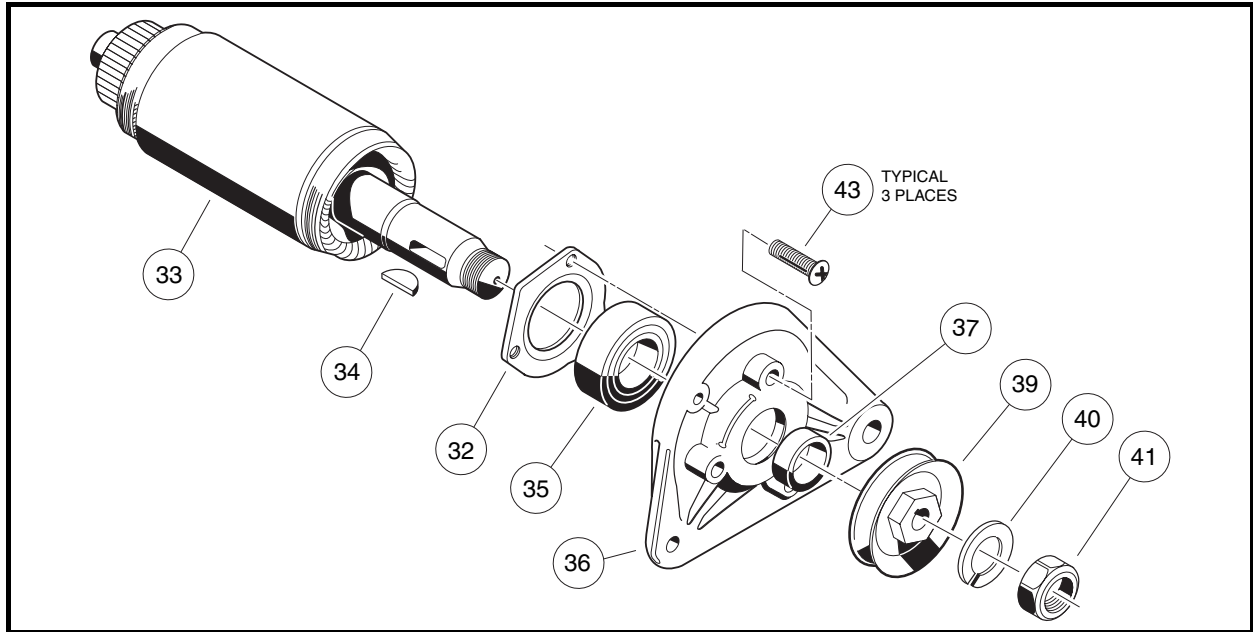

Figure 13-7 Armature and Output End Cover Assembly

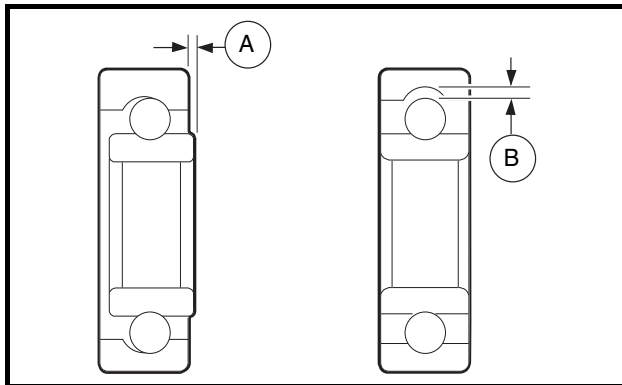

Figure 13-8 Bearing Play Inspection

Bearing Removal

1. Place the wedge attachment tool (CCI P/N 1012812) between the bearing and the armature. Make sure the wedge attachment tool is supporting the inner race of the bearing. If a press is not available, secure a bearing puller (CCI P/N 1012811) to the wedge attachment tool and pull the bearing off of the end of the armature shaft. Support the armature so that it will not drop when the bearing is removed (Figure 13-9, Page 13-6).
2. Discard the bearings.
3. Slide the bearing retainer (32) off of the output end of the shaft (Figure 13-7, Page 13-5).

Field Coil Removal

1. Remove the retaining nut from each field coil terminal and slide the insulator out of the slots in the housing. Remove the four pole piece screws from the housing. Remove the four pole pieces from inside the housing. Remove the field coils from the inside of the housing (Figure 13-10, Page 13-6). See following NOTE.

NOTE: Do not remove the insulators or the field coils unless an electrical test indicates that it is necessary (Figure 13-10, Page 13-6). See Test Procedure 8, Section 11, Page 11-17.

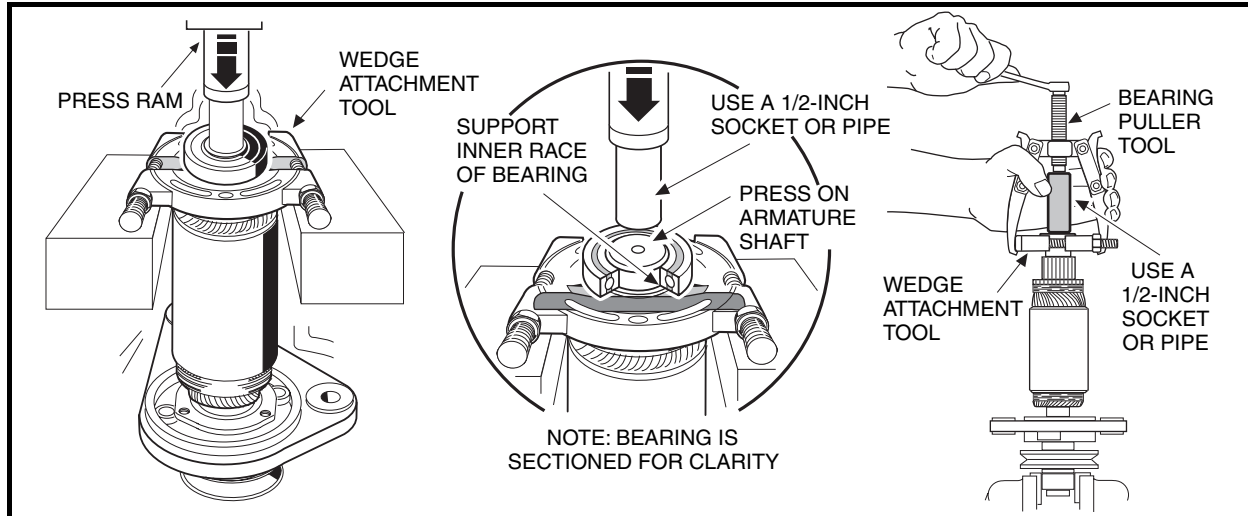

Figure 13-9 Bearing Removal

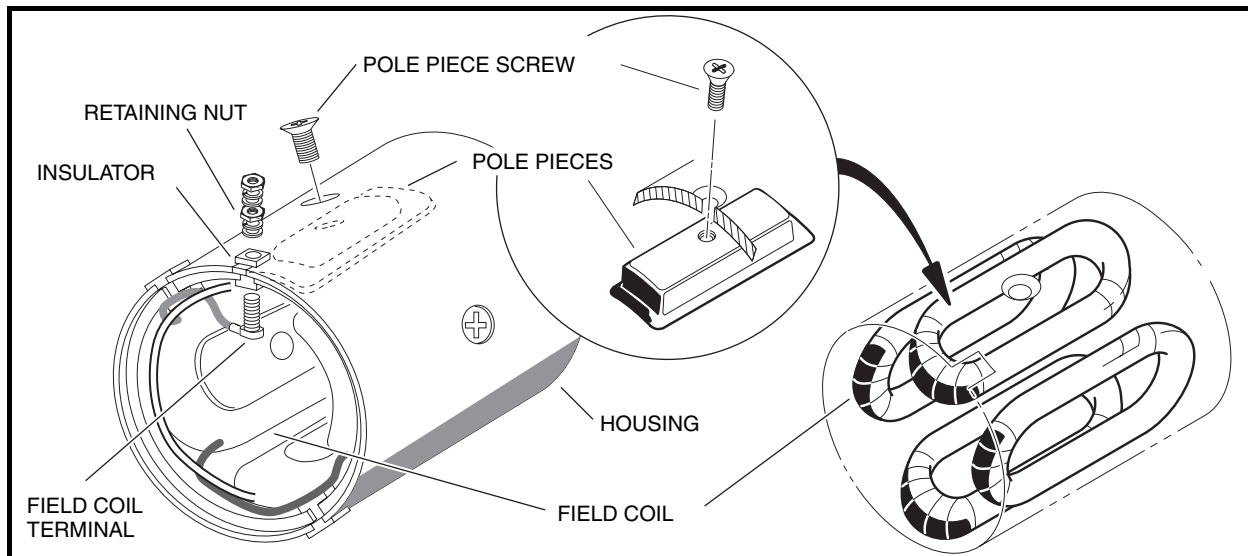

Figure 13-10 Field Coil Removal

Visual Inspection of Armature and Commutator

Some defects can be seen by examining the armature and commutator. Defects seen during the visual inspection can aid in diagnosing the original cause of the failure. Items to look for are listed below.

- Burned, charred or cracked insulation
- Improperly cured varnish
- Thrown solder
- Flared armature windings
- Worn, burned or glazed commutator
- Loose or raised commutator bars
- Bruised or damaged armature core laminations
- Worn armature bearing or shaft
- Dirty or oily commutator

Commutator Cleaning and Inspection

1. Clean the carbon dust, dirt and oil from the commutator. Slight roughness of the commutator can be polished away with 400 grit (or finer) sandpaper. **See following CAUTION.**

CAUTION

- **Never use emery cloth on the commutator. Particles of emery are conductive and may short-circuit the commutator bars. Never use oil or lubricants on the commutator or brushes.**
2. Use a micrometer and measure the outside diameter at four points: two points 90° to each other to the outside end of the commutator (A¹ and A²), and two points 90° to each other to the inside of the commutator (B¹ and B²). If the commutator diameter is less than 1.535 inches (39 mm) at any of the four locations, replace the armature assembly and bearings (**Figure 13-11, Page 13-7**).

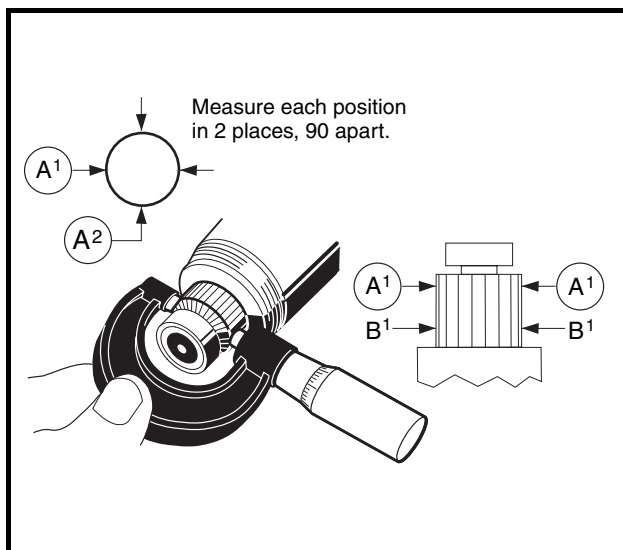

Figure 13-11 Inspect Commutator

Armature Ground Test

CAUTION

- **Do not submerge armature in solvent.**

NOTE: Before testing, wipe the armature with a clean cloth and remove carbon dust and metal particles from between commutator bars.

1. Use a multimeter set on 200 ohms and place the positive (+) probe on the commutator bars and the negative (-) probe on the armature core. The reading should be no continuity. If the reading is incorrect, replace the armature and the two bearings (**Figure 13-12, Page 13-8**).

Visual Inspection of Field Coils

Burned, blackened, charred or scorched coil insulation indicates the starter/generator has overheated due to overloads, grounding or shorted coil windings and should be replaced. Be sure the insulators are tight in the housing.

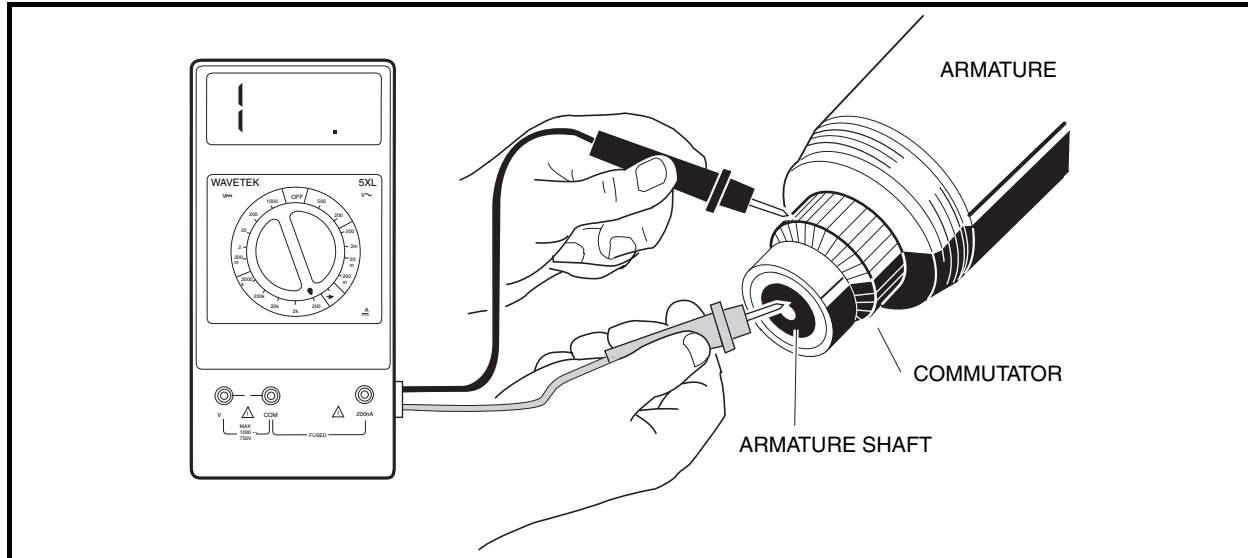

Figure 13-12 Armature Ground Test

Starter/Generator Rework

Any rework must be performed by a qualified technician. Starter/Generator service specifications are listed in the following table.

ITEM	SERVICE LIMIT
Commutator diameter (minimum)	1.535 in. (39 mm)
Concentric with armature shaft within	0.002 in. (0.051 mm)
Limit depth of cut when machining commutator	0.007 in. (0.2 mm)
If undercut of segment insulator is less than 0.016 inch (0.406 mm), then it should be undercut to	0.031 in. (0.8 mm)
Dielectric strength	500 VAC for one minute
Armature insulation resistance	0.2M ohms at 500 VDC
Starter field coil resistance	0.006-0.01 ohms
Generator field coil resistance	4.5-5.5 ohms

Starter/Generator Assembly

1. Place the field coil into the housing. The two insulators that look alike fit into the slots next to the F1 and F2 markings on the outside of the housing. The insulator that looks different slides into the slot next to the DF marking.
2. After the insulators are seated in the slots, install the threaded terminals through the wire connectors and then through the insulators. Install a flat washer, lockwasher and nut onto each threaded terminal on the outside of the housing. Tighten nuts to 47.5 in-lb (5.4 N·m) (**Figure 13-10, Page 13-6**). See following **CAUTION**.

CAUTION

- **Route the field terminal wires so that they will not contact the armature.**

3. Install the four pole pieces into the housing. Use the four screws to secure pole pieces to the inside of the housing to retain the field wires. Tighten screws to 9 ft-lb (12.2 N·m) (**Figure 13-10, Page 13-6**).
4. Slide the bearing retainer onto the output end of the armature shaft (33) so that it will hold the outside of the bearing (35) only (**Figure 13-7, Page 13-5**).
5. Press a new ball bearing (35) onto the output end of the armature (**Figure 13-7, Page 13-5**). Press a new ball bearing onto the commutator end of the armature shaft. **See following CAUTION.**

CAUTION

- **Use care while pressing new bearing onto the output end of the shaft to prevent damage to the retainer.**
- **Press against the inner race of the new bearing until it is fully seated.**

6. Install the output end cover (36) onto the armature. Secure the bearing retainer (32) to the cover and tighten the screws (43) to 39 in-lb (4.4 N·m) (**Figure 13-7, Page 13-5**).
7. Slide the housing with field coils over the armature. Use the locating pin to align housing to the cover.

NOTE: *The terminal insulators should be on the commutator end of the housing.*

8. Install the commutator. Lift the brush springs out of the notches in the brushes and pull the brushes back from the center of the commutator end cover to avoid interference. The springs will rest on the sides of the brushes and help prevent them from sliding to the center of the cover (**Figure 13-6, Page 13-4**).
9. Install the commutator end cover (23) onto the armature shaft. Align the locating pin and hole in the cover. Install the two M6 x 180 mm bolts (20) and tighten to 100 in-lb (11.3 N·m) (**Figure 13-2, Page 13-2**).
10. Push the brushes down into the holders. Place springs into the notches in the brushes. Install the brush cover (30) that has the drain hole in it next to the A2 terminal. Install the remaining three brush covers (29) onto the openings in the commutator end cover (23) (**Figure 13-3, Page 13-2**).
11. Slide the spacer (37) onto the end of the shaft. Insert the shaft key (34) into the shaft. Install the belt pulley (39) onto the shaft and install the lockwasher (40) and M14 nut (41) and tighten the nut to 28 ft-lb (38 N·m) (**Figure 13-7, Page 13-5**).

Starter/Generator Installation

1. Install the green wire from the F1 terminal to the A1 terminal on the starter/generator (**Figure 13-1, Page 13-2**). Install a flat washer, lockwasher, and nut onto each terminal and tighten to 48 in-lb (5.4 N·m).
2. Install two 3/8-inch hex-head pivot bolts (5) into the mounting bracket with the heads of the bolts facing towards the driver side of the vehicle. Position the starter/generator in the mounting bracket so that the bolts will go through the starter/generator before going through the bracket. Install a locknut (7) onto each bolt and tighten to finger-tight (**Figure 13-13, Page 13-10**).
3. Install the adjustment bolt (11) through the adjusting bracket (4) and then through the starter/generator. Install a lockwasher (9) and 5/16-inch nut (12) onto the end of the adjustment bolt (11) and tighten to finger-tight (**Figure 13-13, Page 13-10**).
4. Install the belt (3), then tighten the mounting bolts. **See Belt Tension Adjustment on page 13-10.**
5. Connect the yellow wire from the voltage regulator to the DF terminal on the starter/generator. Install a flat washer, lockwasher and nut onto the terminal and tighten the nut to 31 in-lb (3.5 N·m).

- Install the white wire from the solenoid to the F2 terminal on the starter/generator. Install the black wire from the frame to the A2 terminal on the starter/generator. Install a flat washer, lockwasher and nut onto each terminal, and tighten the nut to 48 in-lb (5.4 N·m).
- Connect the battery cables, positive (+) cable first, and tighten the terminals to 144 in-lb (16.3 N·m). Coat terminals with Battery Terminal Protector Spray (CCI P/N 1014305).

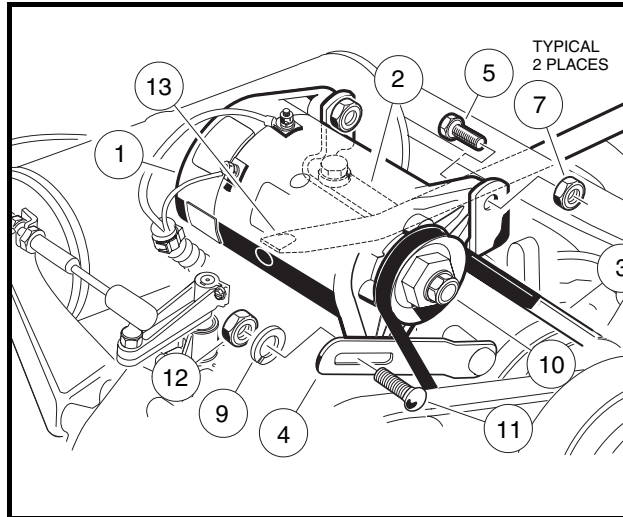

Figure 13-13 Starter/Generator Assembly

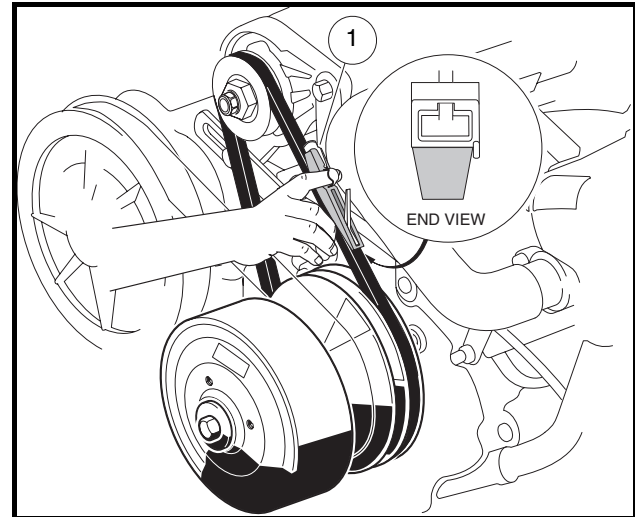

Figure 13-14 Belt Tension Gauge

Belt Tension Adjustment

Belt tension should be checked periodically. If the belt slips when starter/generator motor operates, adjust belt to correct tension.

- Turn the key switch is OFF and remove the key. Place the Forward/Reverse handle in the NEUTRAL position. Chock the wheels.
- Disconnect the battery cables as instructed. **See WARNING “To avoid unintentionally starting...” in General Warning on page 1-2.**
- Make sure the two pivot bolts (5) on the mounting bracket, carriage bolt (11) and hex nut (12) are finger-tight (**Figure 13-13, Page 13-10**).
- Push the starter/generator down to its lowest point of adjustment travel. With the starter/generator belt in place around the drive clutch pulley, install the starter/generator belt (3).
- Place a pry bar (13) between the top of the starter/generator mounting bracket (2) and the underside of the starter/generator, by passing the pry bar under the exhaust header.
- Hold the pry bar and measure the belt tension using a Krikit[®] gauge (1) (available at NAPA[®] Auto Parts stores), or equivalent. Proper tension for a new starter/generator belt should be 75 ft-lb (101.7 N·m), or 45 ft-lb (61 N·m) for an existing belt (**Figure 13-14, Page 13-10**).
- While maintaining the tension, tighten the adjustment nut (12) to 144 in-lb (16.3 N·m). Tighten the two pivot bolts (5) and hex nuts (7) to 23 ft-lb (31.2 N·m) (**Figure 13-13, Page 13-10**). **See following CAUTION.**

CAUTION

- Remove pry bar before starting engine.

- Connect the battery cables, positive (+) cable first, and tighten the terminals to 144 in-lb (16.3 N·m). Coat terminals with Battery Terminal Protector Spray (CCI P/N 1014305).

VOLTAGE REGULATOR

See General Warning on page 1-1.

Testing the Voltage Regulator

See Test Procedure 12, Section 11, Page 11-20.

Voltage Regulator Removal

1. Turn the key switch OFF and remove the key. Place the Forward/Reverse handle in the NEUTRAL position. Chock the wheels.
2. Disconnect the battery cables as instructed. **See WARNING “To avoid unintentionally starting...” in General Warning on page 1-2.**
3. Remove the air intake hose from the carburetor.
4. Remove the electrical component box cover.
5. Disconnect the voltage regulator red wire (1) at the large post on the solenoid, the yellow wire (4) at the bullet connector and the black wire (7) from the wire harness and at the battery frame ground (**Figure 13-15, Page 13-12**).
6. Remove the voltage regulator mounting screw (8) and remove the voltage regulator (9).

Voltage Regulator Installation

1. Position the voltage regulator (9) in the electrical component box and install the mounting screw (8) and tighten screw to 23 in-lb (2.6 N·m) (**Figure 13-15, Page 13-12**).
2. Connect the voltage regulator red wire (1) at the large post on the solenoid with the other red wires, the yellow wire (4) at the bullet connector and the black wire (7) to the wire harness and the battery frame ground (**Figure 13-15, Page 13-12**).
3. Install electrical component box cover. Be sure to firmly press down all corners. Install screw and tighten to 18 in-lb (2 N·m).
4. Install the air intake hose onto the carburetor.
5. Connect the battery cables, positive (+) cable first, and tighten the terminals to 144 in-lb (16.3 N·m). Coat terminals with Battery Terminal Protector Spray (CCI P/N 1014305).
6. With the Forward/Reverse handle in the NEUTRAL position, start the engine and check regulator for proper functioning as described in the voltage regulator test procedure. **See Test Procedure 12, Section 11, Page 11-20.**

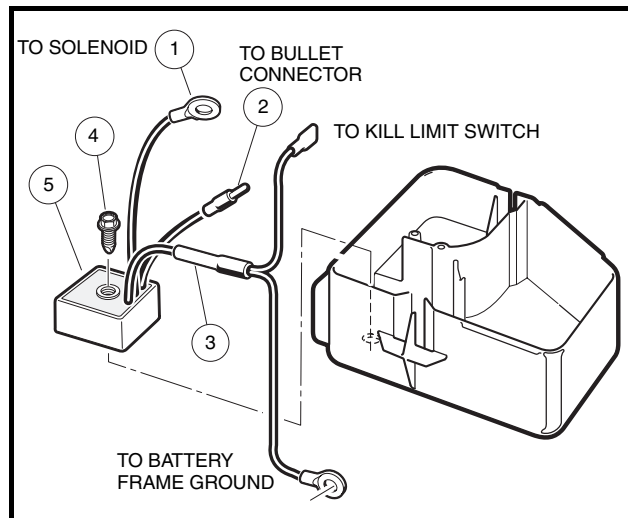

Figure 13-15 Voltage Regulator

DIODE

See General Warning on page 1-1.

Testing the Diode

See Test Procedure 10, Section 11, Page 11-18.

Diode Removal

1. Turn the key switch OFF and remove the key. Place the Forward/Reverse handle in the NEUTRAL position. Chock the wheels.
2. Disconnect the battery cables as instructed. **See WARNING "To avoid unintentionally starting..." in General Warning on page 1-2.**
3. Remove the carburetor air intake hose to allow easy access to the electrical component box cover.
4. Remove the cover screw (5) and electrical component box cover (6) (**Figure 13-16, Page 13-13**).
5. Remove the nuts (7) from the two large solenoid posts and disconnect the diode wires from the solenoid.
 - 5.1. Observe color orientation of the wires with the terminal locations on the solenoid. The 12-gauge red wire from the diode should be attached to the same terminal as the red wire from the fuse block, and the red wire from the battery. The 12-gauge white wire should be attached to the other large solenoid post, along with the red wire from the voltage regulator and the white wire from the starter/generator.
6. Remove the nut (3) and remove the diode (2) and thermal transfer pad (1) from the vehicle frame (**Figure 13-16, Page 13-13**).

Diode Installation

1. Thoroughly clean and dry the area of the I-beam where the new diode is to be attached.
2. Peel the protective film from both sides of the new thermal pad (1) (**Figure 13-16, Page 13-13**). **See following CAUTION.**

CAUTION

- Be sure to remove and discard the protective film from both sides of the thermal pad before installing it. If not removed, the film will reduce the thermal heat transfer and therefore reduce the power handling capability of the diode, causing it to overheat and damage the electrical system.

3. Mount the diode (2) using the thermal transfer pad (1) and mounting nut (3) and tighten to 25 in-lb (2.8 N·m) (Figure 13-16, Page 13-13). See following NOTE.

NOTE: Diodes are mounted in one of two different locations, depending on the vehicle model (Figure 13-16, Page 13-13).

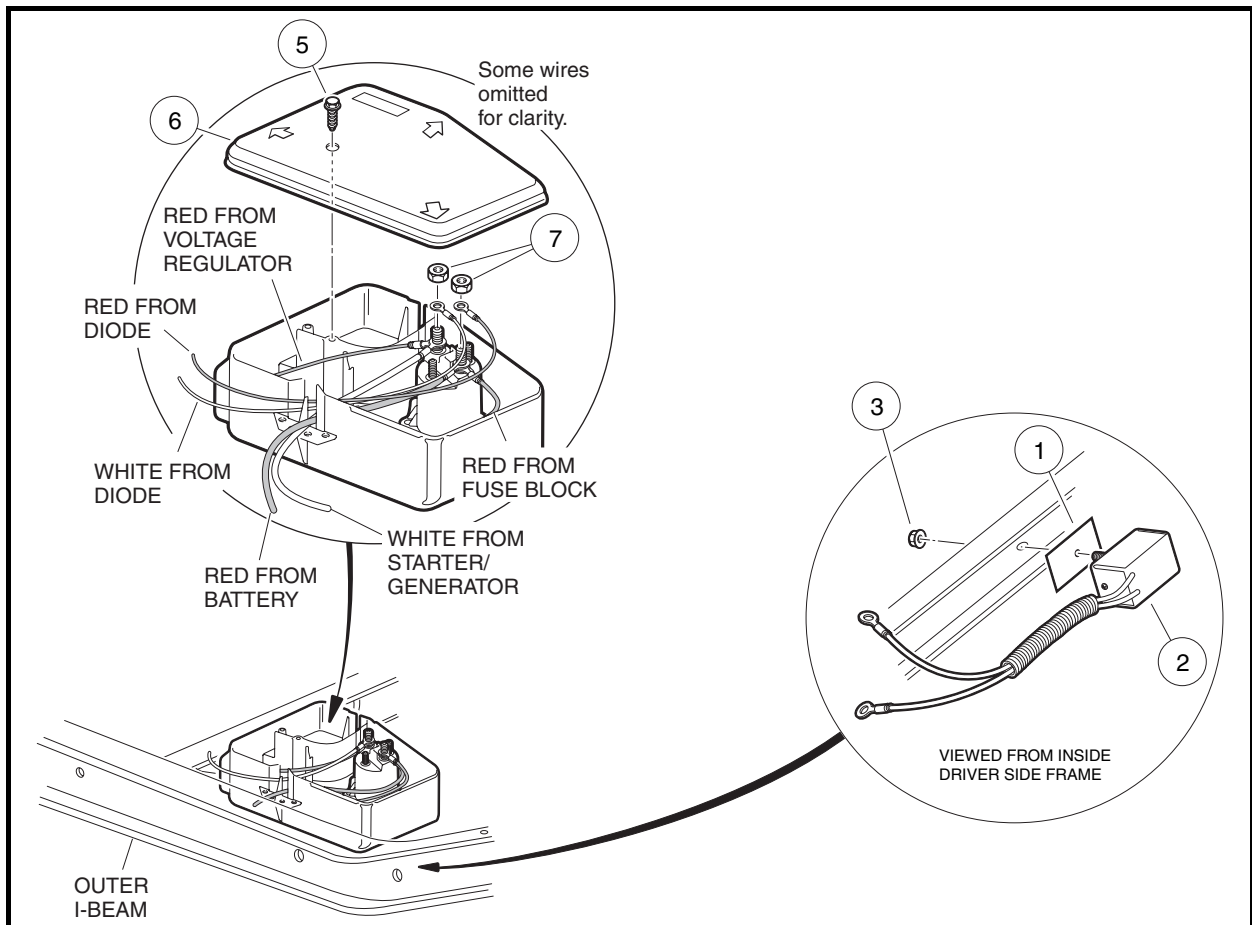

Figure 13-16 Electrical Component Box and Diode Orientation

4. Route and connect the red and white diode wires to the solenoid posts in the electrical component box. See following WARNING.

⚠ WARNING

- Incorrect wiring could result in severe injury or death.
- Diode and solenoid connections must have correct polarity.
- Keep all persons clear of engine belts when making final connections.

- 4.1. Connect the 12-gauge red wire from the diode to the solenoid post with the fuse block and battery red wires and tighten locknut (7) to 55 in-lb (6.2 N·m) **(Figure 13-16, Page 13-13)**.
- 4.2. Connect the 12-gauge white wire to the other large solenoid post, along with the red wire from the voltage regulator and white wire from the starter/generator and tighten nut (7) to 55 in-lb (6.2 N·m).
5. Replace the electrical component box cover (6) and screw (5) and tighten the screw to 18 in-lb (2.0 N·m).
6. Connect the intake hose to the carburetor and secure the hose with the hose clamp.
7. Connect the battery cables, positive (+) cable first, and tighten the terminals to 144 in-lb (16.3 N·m). Coat terminals with Battery Terminal Protector Spray (CCI P/N 1014305).

KEY SWITCH

See General Warning on page 1-1.

Testing the Key Switch

See Test Procedure 4, Section 11, Page 11-13. Also see Test Procedure 17 – Key Switch (Engine Kill Circuit) on page 11-28.

Key Switch Removal

1. Turn the key switch OFF and remove the key. Place the Forward/Reverse handle in the NEUTRAL position. Chock the wheels.
2. Disconnect the battery cables as instructed. See **WARNING “To avoid unintentionally starting...” in General Warning on page 1-2.**
3. Remove the instrument panel.
 - 3.1. Loosen seven Tuflok screws, but do not remove screws completely, as shown in Detail A **(Figure 13-18, Page 13-15)**.
 - 3.2. Remove Tuflok screws from instrument panel as shown in Detail B.
 - 3.3. Pull forward on top of instrument panel to access back side of key switch.
 - 3.4. Disconnect the wire connector from the key switch.
4. Remove the key switch.
 - 4.1. Remove the key switch nut (1) **(Figure 13-17, Page 13-14)**.
 - 4.2. Remove key switch (2) from back side of instrument panel.

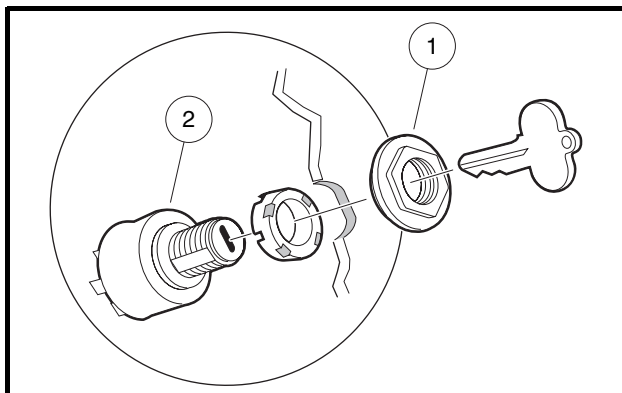

Figure 13-17 Key Switch Removal

Key Switch Installation

1. Install the key switch in the dash in reverse order of removal. Tighten the key switch nut firmly. Reconnect the wire connector to the key switch.
2. Install the instrument panel in reverse order of removal. **See Key Switch Removal on page 13-14.**
3. Connect the battery cables, positive (+) cable first, and tighten the terminals to 144 in-lb (16.3 N·m). Coat terminals with Battery Terminal Protector Spray (CCI P/N 1014305).

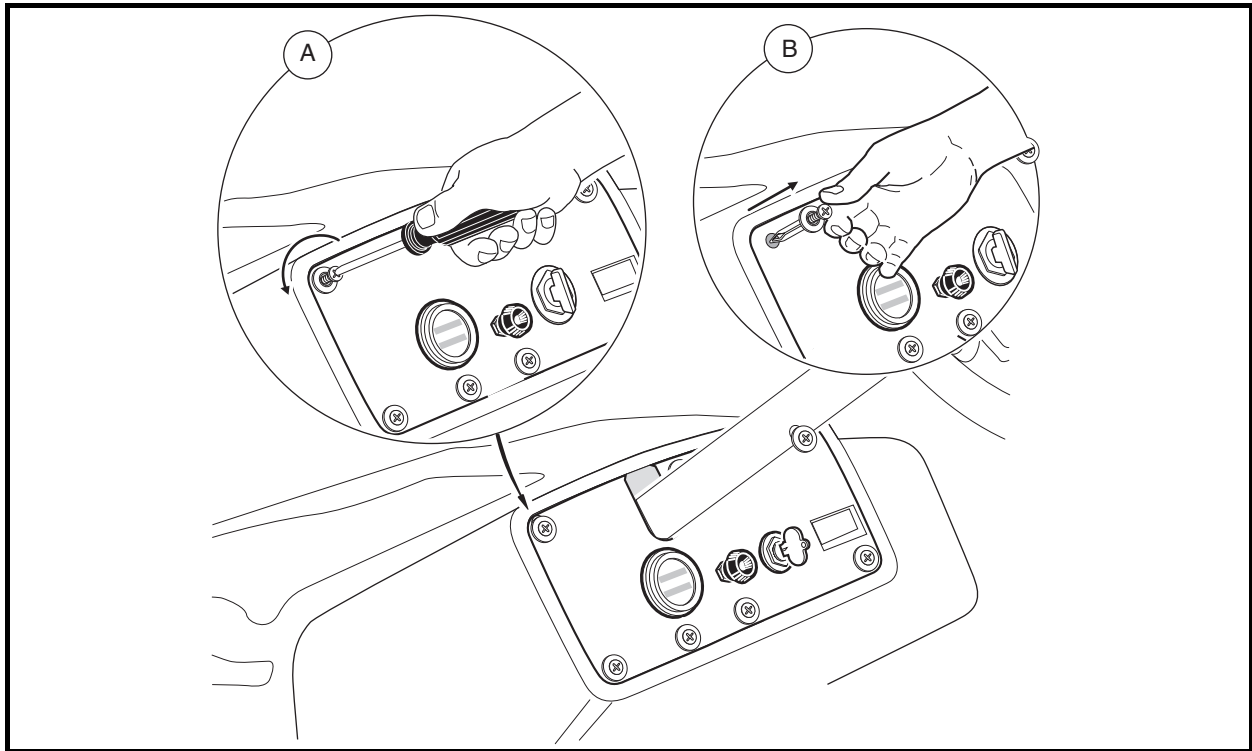

Figure 13-18 Instrument Panel Removal

SOLENOID

See **General Warning** on page 1-1.

Testing the Solenoid

See **Test Procedure 6, Section 11, Page 11-15.**

Solenoid Removal

1. Turn the key switch OFF and remove the key. Place the Forward/Reverse handle in the NEUTRAL position. Chock the wheels.
2. Disconnect the battery cables as instructed. **See WARNING “To avoid unintentionally starting...” in General Warning on page 1-2.**
3. Remove the air intake hose from the carburetor.
4. Remove electrical component box cover.
5. Disconnect all the wires from the solenoid.
6. Remove the two screws securing the solenoid in place.

Solenoid Installation

1. Install the solenoid in the electrical component box using two screws to secure the solenoid to the box and tighten to 14 in-lb (1.6 N·m). **See following WARNING.**

⚠ WARNING

- **Incorrect wiring could result in severe injury or death.**
 - **Diode and solenoid connections must have correct polarity.**
 - **Keep all persons clear of engine belts when making final connections.**
2. Connect all wires as indicated.
 - 2.1. Connect the 6-gauge white wire from the starter/generator, 18-gauge red wire from the voltage regulator, and the 12-gauge white wire from the diode to the large post on the solenoid. **See Wiring Diagrams, Section 11, Page 11-6.**
 - 2.2. Connect the 6-gauge red wire from the battery, the 10-gauge red wire from the fuse block, and the 12-gauge red wire from the diode to the other large post on the solenoid.
 - 2.3. Connect the 18-gauge blue wire from the key switch to the small post on the solenoid.
 - 2.4. Connect the 18-gauge green wire from the Forward/Reverse limit switch to the other small post on the solenoid.
 3. Tighten the hex nuts on the large solenoid posts to 55 in-lb (6.2 N·m). Tighten the nuts on the small solenoid posts to 22 in-lb (2.5 N·m).
 4. Install the snap-on electrical box cover by firmly pressing down on all corners and install the screw and tighten to 18 in-lb (2 N·m).
 5. Install the air intake hose onto the carburetor.
 6. Connect the battery cables, positive (+) cable first, and tighten the terminals to 144 in-lb (16.3 N·m). Coat terminals with Battery Terminal Protector Spray (CCI P/N 1014305).

FUSE

See General Warning on page 1-1.

Testing the Fuse

See Test Procedure 2, Section 11, Page 11-11.

Fuse Removal

1. Turn the key switch OFF and remove the key. Place the Forward/Reverse handle in the NEUTRAL position. Chock the wheels.
2. Disconnect the battery cables as instructed. **See WARNING “To avoid unintentionally starting...” in General Warning on page 1-2.**
3. Remove the air intake hose from the carburetor.
4. Remove electrical component box cover.
5. Remove the fuse from the fuse block.

Fuse Installation

1. Install the fuse. **See following WARNING.**

⚠ WARNING

- **If a fuse is blown, determine the cause of the failure and make necessary repairs before installing a new fuse. Use the appropriately rated fuse; if a fuse with a higher amp rating is used, damage to the vehicle electrical system may occur.**
2. Install the snap-on electrical box cover by firmly pressing down on all corners and install the screw and tighten to 18 in-lb (2 N·m).
 3. Install the air intake hose onto the carburetor.
 4. Connect the battery cables, positive (+) cable first, and tighten the terminals to 144 in-lb (16.3 N·m). Coat terminals with Battery Terminal Protector Spray (CCI P/N 1014305).

LOCKOUT CAM LIMIT SWITCH

See General Warning on page 1-1.

Testing the Lockout Cam Limit Switch

See Test Procedure 7, Section 11, Page 11-15.

Lockout Cam Limit Switch Removal

1. Turn the key switch OFF and remove the key. Place the Forward/Reverse handle in the NEUTRAL position. Chock the wheels.
2. Disconnect the battery cables as instructed. **See WARNING “To avoid unintentionally starting...” in General Warning on page 1-2.**
3. Disconnect the wires from the lockout cam limit switch (5) located on the back of the Forward/Reverse shifter assembly (**Figure 13-19, Page 13-18**).
4. Remove two nuts (2) and washers (6) from the lockout cam limit switch (5) and slide the lockout cam limit switch off of the screws.

Lockout Cam Limit Switch Installation

1. Install the limit switch (5) with washers (6) and nuts (2) and tighten to 5 in-lb (0.6 N·m) (**Figure 13-19, Page 13-18**). Place the Forward/Reverse handle in REVERSE to make sure that both switches actuate. **See following CAUTION.**

⚠ CAUTION

- **Do not overtighten the retaining nuts. If the nuts are overtightened, limit switches could be damaged.**
2. Connect the black wire to the common (COM) terminal and the green wire to the normally open (NO) terminal of the lockout cam limit switch. **See Wiring Diagrams, Section 11, Page 11-6.**
 3. Connect battery cables, positive (+) cable first, and tighten the terminals to 144 in-lb (16.3 N·m). Coat terminals with Battery Terminal Protector Spray (CCI P/N 1014305).
 4. With the Forward/Reverse handle in the NEUTRAL position, the lockout cam should be activating the lockout cam limit switch. Make sure everyone is clear of the vehicle.
 5. Turn the key switch to the START position. The engine should crank only when the Forward/Reverse handle is in the NEUTRAL position.
 6. Test drive the vehicle in both forward and reverse for proper operation.

LOCKOUT CAM

See General Warning on page 1-1.

If the cam lobes have worn to the point where they will no longer actuate the lockout cam limit switch, the cam must be replaced.

Testing the Lockout Cam

See Test Procedure 23, Section 11, Page 11-31.

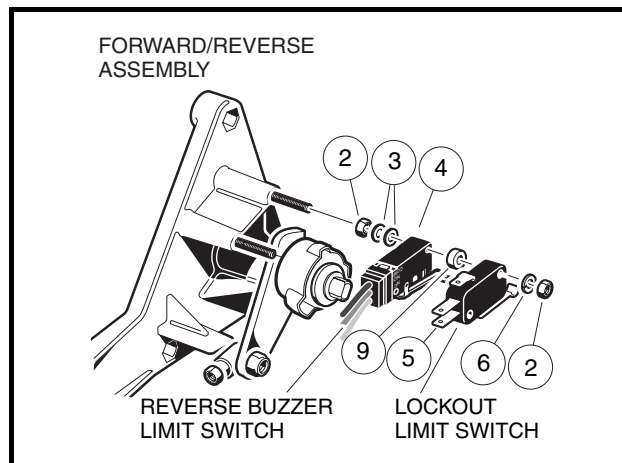

Figure 13-19 Lockout Cam and Reverse Buzzer Limit Switches

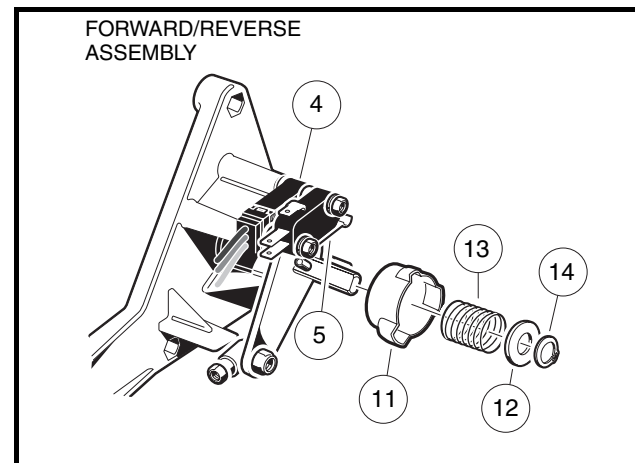

Figure 13-20 Lockout Cam

Lockout Cam Removal

1. Turn the key switch OFF and remove the key. Place the Forward/Reverse handle in the NEUTRAL position. Chock the wheels.
2. Disconnect the battery cables as instructed. See **WARNING** "To avoid unintentionally starting..." in **General Warning on page 1-2**.
3. Remove the external snap ring (14) (**Figure 13-20, Page 13-18**).
4. Remove the plastic washer (12) and the spring (13).
5. Remove the cam (11).

Lockout Cam Installation

1. Install the cam (11) (**Figure 13-20, Page 13-18**).
2. Install the spring (13) and the plastic washer (12).
3. Install the external snap ring (14) into the groove on the shaft. The lockout limit switch should be activated only when the Forward/Reverse handle is in the NEUTRAL position.
4. Connect battery cables, positive (+) cable first, and tighten the terminals to 144 in-lb (16.3 N·m). Coat terminals with Battery Terminal Protector Spray (CCI P/N 1014305).

REVERSE WARNING BUZZER

See General Warning on page 1-1.

Testing the Reverse Warning Buzzer

See Test Procedure 20, Section 11, Page 11-30.

Reverse Warning Buzzer Removal

1. Turn the key switch OFF and remove the key. Place the Forward/Reverse handle in the NEUTRAL position. Chock the wheels.
2. Disconnect the battery cables as instructed. See **WARNING “To avoid unintentionally starting...”** in General Warning on page 1-2.
3. Remove the instrument panel. See **Key Switch Removal** on page 13-14.
4. Disconnect the wires from the reverse warning buzzer (2) (**Figure 13-21, Page 13-19**).
5. Remove the screw (3), nut (4), lockwasher (5) and flat washer (6) securing the buzzer to the vertical frame support.

Reverse Warning Buzzer Installation

1. Install the screw (3) through the buzzer (2) bracket tab and frame, secure with hardware, and tighten to 14 in-lb (1.6 N·m) (**Figure 13-21, Page 13-19**). See following **NOTE**.

NOTE: The reverse warning buzzer is secured at one hole only.

2. Connect the black wire from the wire harness to the negative (-) terminal on the buzzer.
3. Connect the red/white wire from the wire harness to the positive (+) terminal on the buzzer.
4. Install the dash in reverse order of removal. See **Key Switch Removal** on page 13-14.
5. Connect battery cables, positive (+) cable first, and tighten the terminals to 144 in-lb (16.3 N·m). Coat terminals with Battery Terminal Protector Spray (CCI P/N 1014305).

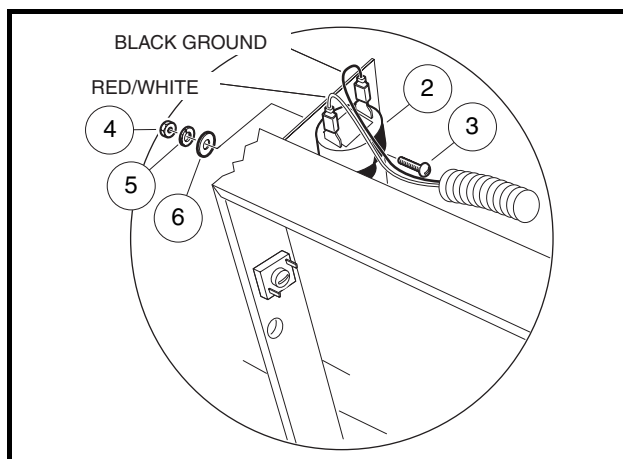

Figure 13-21 Front Reverse Warning Buzzer

REVERSE BUZZER LIMIT SWITCH

See General Warning on page 1-1.

Testing the Reverse Buzzer Limit Switch

See Test Procedure 19, Section 11, Page 11-30.

Reverse Buzzer Limit Switch Removal

1. Turn the key switch OFF and remove the key. Place the Forward/Reverse handle in the NEUTRAL position. Chock the wheels.
2. Disconnect the battery cables as instructed. See **WARNING “To avoid unintentionally starting...”** in **General Warning on page 1-2.**
3. Disconnect the wires from the reverse buzzer limit switch (4) located on the back of the Forward/Reverse assembly (**Figure 13-19, Page 13-18**).
4. Remove the nuts (2) and washers (6) from the lockout cam limit switch (5) and slide the lockout cam limit switch off of the screws. Do not disconnect the wires.
5. Remove the spacers (9) from the reverse buzzer limit switch (4) and slide the reverse buzzer limit switch off the screws.

Reverse Buzzer Limit Switch Installation

1. Install the reverse buzzer limit switch (4), and then install two spacers (9) against the limit switch.
2. Install the lockout cam limit switch (5) with two washers (6) and two nuts (2) and tighten to 5 in-lb (0.6 N·m). See following **CAUTION**.

CAUTION

- Do not overtighten the retaining nuts. If the nuts are overtightened, limit switches could be damaged.
3. Place the Forward/Reverse handle in REVERSE to make sure that only the reverse buzzer limit switch is actuated.
 4. Connect the orange wire to the black wire (COM) terminal and the red/white wire to the blue wire, normally open (NO) terminal of the reverse buzzer limit switch (4) (**Figure 13-19, Page 13-18**).
 5. Connect the battery cables, positive (+) cable first, and tighten the terminals to 144 in-lb (16.3 N·m). Coat terminals with Battery Terminal Protector Spray (CCI P/N 1014305).
 6. Turn the key switch to the ON position. With the Forward/Reverse handle in REVERSE, the buzzer should sound.

OIL WARNING LIGHT

See General Warning on page 1-1.

Testing the Oil Warning Light

See Test Procedure 22, Section 11, Page 11-31.

Oil Warning Light Removal

1. Turn the key switch OFF and remove the key. Place the Forward/Reverse handle is in the NEUTRAL position. Chock the wheels.
2. Disconnect the battery cables as instructed. See **WARNING “To avoid unintentionally starting...”** in **General Warning on page 1-2.**

3. Remove the instrument panel. **See Key Switch Removal on page 13-14.**
4. Disconnect the wires from the oil warning light (1) (**Figure 13-22, Page 13-21**). Do not allow wires to touch.
5. Press the retaining tabs and remove the light from the instrument panel.

Oil Warning Light Installation

1. Push a new unit into hole in dash until plastic tabs engage dash (**Figure 13-22, Page 13-21**).
2. Connect the two yellow wires from the wire harness to the oil warning light.
3. Install the dash in reverse order of removal. **See Key Switch Removal on page 13-14.**
4. Connect the battery cables, positive (+) cable first, and tighten the terminals to 144 in-lb (16.3 N·m). Coat terminals with Battery Terminal Protector Spray (CCI P/N 1014305).

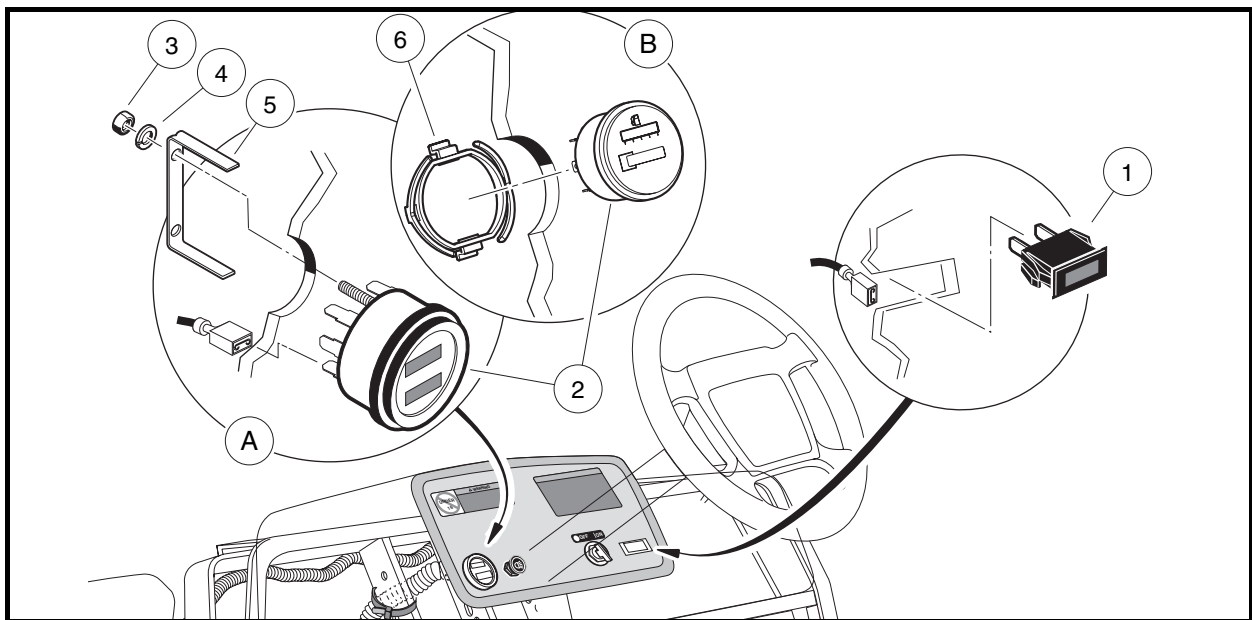

Figure 13-22 Fuel Gauge/Hour Meter and Oil Warning Light Assembly

A. Used 2006 through mid-2007 Model Year B. Started mid-2007 Model Year

FUEL GAUGE/HOUR METER

See General Warning on page 1-1.

Testing the Fuel Gauge/Hour Meter

See Test Procedure 26, Section 11, Page 11-33. Also see Test Procedure 27 – Hour Meter on page 11-35.

2006 to mid-2007 vehicles: With the key switch in the OFF position, the fuel gauge/hour meter fields are blank. When the key switch is turned to ON, both fields activate. **Mid-2007 and newer vehicles:** With the key switch in the OFF position, the fuel gauge field is blank; however, the hour meter field is always ON. When the key switch is turned to ON, the fuel gauge field activates. **All model years:** The fuel gauge initially registers full before indicating the actual fuel level.

The hour meter displays the number of hours of use in increments of 0.1 (one tenth) hour, but does not record additional time unless the key switch is in the ON position and the engine is on. When recording, the hour-glass icon on the left blinks (slowly on Early 2007 vehicles).

Fuel Gauge/Hour Meter Removal

1. Turn the key switch OFF and remove the key. Place the Forward/Reverse handle in the NEUTRAL position. Chock the wheels.
2. Disconnect the battery cables as instructed. **See WARNING “To avoid unintentionally starting...” in General Warning on page 1-2.**
3. Remove the instrument panel. **See Key Switch Removal on page 13-14.**
4. Disconnect the wires from the fuel gauge/hour meter (2) (**Figure 13-22, Page 13-21**). Do not allow wires to touch.
5. Remove the fuel gauge/hour meter.
 - 5.1. **2006 to mid-2007 vehicles:** Remove the two hex nuts (3) and lockwashers (4) from the threaded studs on the back of the gauge. Remove the mounting bracket (5) from the back side of the gauge/meter and remove it from the instrument panel.
 - 5.2. **Mid-2007 and newer vehicles:** Remove the mounting clip (14) that secures the gauge/meter. Alternate pulling the lower and upper tabs away from the gauge housing to remove clip. Pull gauge/meter from the instrument panel.

Fuel Gauge/Hour Meter Installation

1. Install a new gauge/meter into hole in dash until flange seats against dash (**Figure 13-22, Page 13-21**).
2. Secure the fuel gauge/hour meter.
 - 2.1. **2006 to mid-2007 vehicles:** Slide the mounting bracket onto the two threaded studs on the fuel gauge/hour meter. Secure the fuel gauge/hour meter with two lockwashers and two hex nuts. Tighten to 2.5 in-lb (.28 N·m). Place one drop of Loctite on each hex nut. Do not allow Loctite to come into contact with the fuel gauge/hour meter casing.
 - 2.2. **Mid-2007 and newer vehicles:** Force the mounting clip (14) onto the back of the fuel gauge/hour meter until fully seated.
3. Connect the wires to the fuel gauge/hour meter. **See Wiring Diagrams, Section 11, Page 11-6.**
4. Coat the terminals with Battery Terminal Protector Spray (CCI P/N 1014305).
5. Install the dash in reverse order of removal. **See Key Switch Installation on page 13-15.**
6. Connect the battery cables, positive (+) cable first, and tighten the terminals to 144 in-lb (16.3 N·m). Coat terminals with Battery Terminal Protector Spray (CCI P/N 1014305).

FUEL LEVEL SENDING UNIT

See General Warning on page 1-1.

The fuel level sending unit is an integral part of the fuel tank and should never be removed. Thoroughly test the fuel level sending unit before replacing the fuel tank.

Testing the Fuel Level Sending Unit

See Test Procedure 25, Section 11, Page 11-32.

RPM LIMITER

See General Warning on page 1-1.

Testing the RPM Limiter

See Test Procedure 15, Section 11, Page 11-23.

RPM Limiter Removal

1. Turn the key switch OFF and remove the key. Place the Forward/Reverse handle in the NEUTRAL position. Chock the wheels.
2. Disconnect the battery cables as instructed. See WARNING "To avoid unintentionally starting..." in General Warning on page 1-2.
3. Disconnect the white/black wire from the black wire at the bullet connector located near the RPM limiter (Figure 13-23, Page 13-23).
4. Disconnect the other black wire at the other bullet connector near the RPM limiter.
5. Remove the flange head bolts from the RPM limiter band and remove the RPM limiter and damper (Figure 13-23, Page 13-23).

RPM Limiter Installation

1. Place the RPM limiter on the damper squarely so that RPM limiter fits tightly against the damper.
2. Place the RPM limiter with damper on the front of the RPM limiter mounting bracket (Figure 13-23, Page 13-23).
3. Place the band over the RPM limiter and align the holes. Place the brown wire ring connector onto the flange head bolt and secure the left side of the band. Use another flange head bolt to secure the other side of the band. Make sure the band holds the RPM limiter securely in place. Tighten fasteners to 7 ft-lb (9.5 N·m).
4. Connect the black wire at the two wire female bullet connector to the white/black kill circuit wire.
5. Connect other female bullet of the black coil wire to the ignition coil bullet terminal.
6. Connect the battery cables, positive (+) cable first, and tighten the terminals to 144 in-lb (16.3 N·m). Coat terminals with Battery Terminal Protector Spray (CCI P/N 1014305).

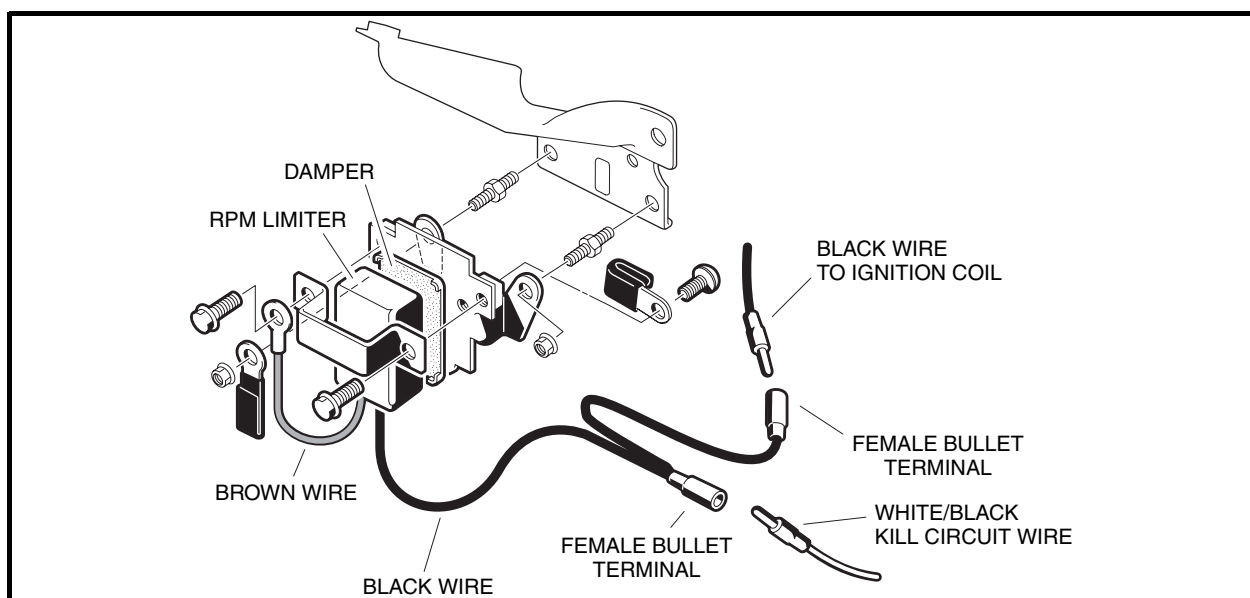

Figure 13-23 RPM Limiter Assembly

IGNITION COIL

See General Warning on page 1-1.

The ignition coil is located under the flywheel shroud of the engine. To replace it requires the removal and installation of the engine and transaxle. It is recommended that the ignition coil be thoroughly tested prior to replacement.

Testing the Ignition Coil

See Test Procedure 14, Section 11, Page 11-22. Also see Test Procedure 15 – RPM Limiter on page 11-23 and Test Procedure 16 – Ignition Coil on page 11-23.

Ignition Coil Removal

Removing the ignition coil requires the removal of the engine and unitized transaxle. See Unitized Transaxle Removal, Section 18, Page 18-6. See following CAUTION.

CAUTION

- Before removal and disassembly, clean the engine.

1. Remove the starter/generator. See Starter/Generator Removal on page 13-1. See following NOTE.

NOTE: The crankshaft has left-hand threads at the clutch mounting hole.

2. Remove the muffler. See Muffler Removal, Section 17, Page 17-1.
3. Remove the engine mounting hardware (items 1, 2, and 5) (Figure 15-4, Page 15-4).
4. Remove the two nuts (6) and washers (3) from the stud bolts on the engine body.
5. Slide the engine away from the transaxle housing and lift the engine from the mounting plate.
6. Place the engine on a solid, flat surface, preferably on a sturdy work bench.
7. Remove the pan head bolts (5) securing the fan shroud (8) to the fan housing (9) (Figure 13-24, Page 13-25).
8. Loosen, but do not remove, three bolts (6) attaching the fan housing as shown.
9. Remove the remaining four bolts (10) attaching the fan housing (Figure 13-24, Page 13-25), then while opening the housing, detach the spark plug wire grommet (4) from the housing (Figure 13-26, Page 13-26).
10. Disconnect the 18-gauge black wire (12) from the spade terminal (13) on the ignition coil (11) and remove the coil by removing two bolts (10) (Figure 13-25, Page 13-25).

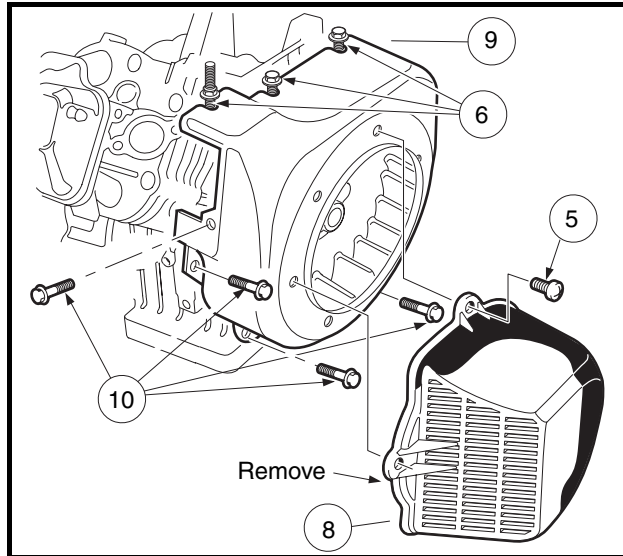

Figure 13-24 Remove Fan Housing

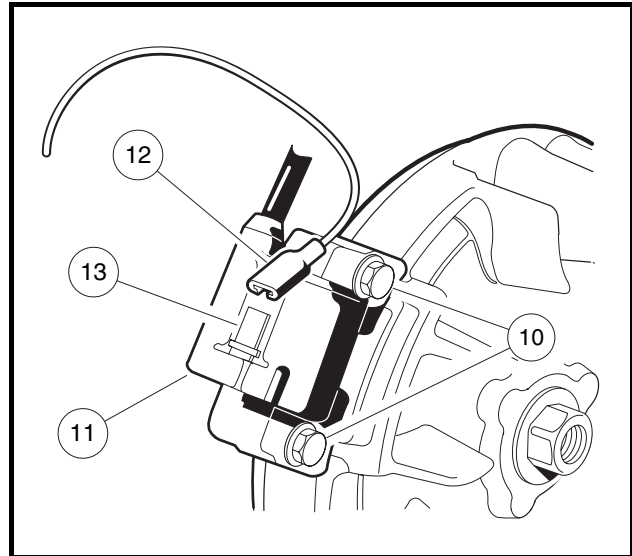

Figure 13-25 Black Wire and Ignition Coil

Ignition Coil Installation

NOTE: If a new ignition coil is being installed, the spark plug cap, gasket, protector tube and grommet must be removed from the old coil and installed on the new coil. See steps 1 through 8 for procedures to remove and install these existing parts.

If the existing ignition coil will be remounted, proceed to step 9.

1. Remove the rubber gasket (1) on the plug cap (2) by rolling back the gasket onto the spark plug wire.
2. Remove the cap (2) from the wire by turning the cap counterclockwise three or four revolutions while gently pulling it off the wire (Figure 13-26, Page 13-26).
3. Remove the gasket (1) and protector tube (3) from the old coil. See following NOTE.

NOTE: Moisten the spark plug wire with water to make gasket removal and installation easier.

4. Remove the grommet (4) from the old spark plug wire. Clean the grommet and place it on the new spark plug wire (5).
5. Install the protector tube (3) onto the new wire (Figure 13-26, Page 13-26).
6. Slide the gasket (1) onto the end of the new spark plug wire.
7. Install the cap (2) on the new coil spark plug wire by rotating it clockwise three or four revolutions while applying light pressure on the cap.
8. Install the gasket (1) on the cap (2).
9. Position the ignition coil (7) onto the cast mounting bosses on the engine crankcase and tighten the two mounting bolts (6) finger-tight.
10. Rotate the flywheel (8) until the magnet is positioned directly under the ignition coil. Use a 0.012 inch (0.304 mm) bronze feeler gauge to set the air gap between the ignition coil and the flywheel magnet. Tighten the two mounting bolts (6) to 30 in-lb (3.4 N·m) (Figure 13-27, Page 13-26).
11. Connect 18-gauge black (12) wire to the spade terminal (13) on the coil (Figure 13-25, Page 13-25).
12. Position the fan housing close to the engine crankcase and slide the plug wire grommet into the notch on the housing.

13. When installing fan housing, make sure the top front corner of the housing is above the upper cylinder shroud. The front edge of the fan housing should be behind the lower cylinder shroud. Align the slots in the housing with the flanged bolts (6) loosened earlier (**Figure 13-24, Page 13-25**).
14. Install the four remaining flanged bolts (10) that secure the fan housing to the engine crankcase. Tighten all seven mounting bolts (6) and (10) to 90 in-lb (10.2 N·m).
15. Install the fan shroud with four pan-head bolts (5) and tighten to 50 in-lb (5.7 N·m).
16. Place the engine onto the engine mounting plate and slide the two washers (3) onto the two engine body bolts, then slide the bolts through the mounting plate and transaxle housing. Loosely attach the two nuts (6) finger-tight (**Figure 15-4, Page 15-4**).
17. Attach the engine to the bottom of the engine mounting plate using the bolts (1), washers (2) and nuts (5). Tighten hardware to 21 ft-lb (28.4 N·m) (**Figure 15-4, Page 15-4**).
18. Tighten the two engine body bolt nuts (6) to 17 ft-lb (23.1 N·m).
19. Install the engine and transaxle assembly. **See Unitized Transaxle Installation, Section 18, Page 18-13. See following CAUTION.**

CAUTION

- **Make sure wire harness is routed and secured away from the muffler.**

20. Install the muffler. **See Muffler Installation, Section 17, Page 17-1.**

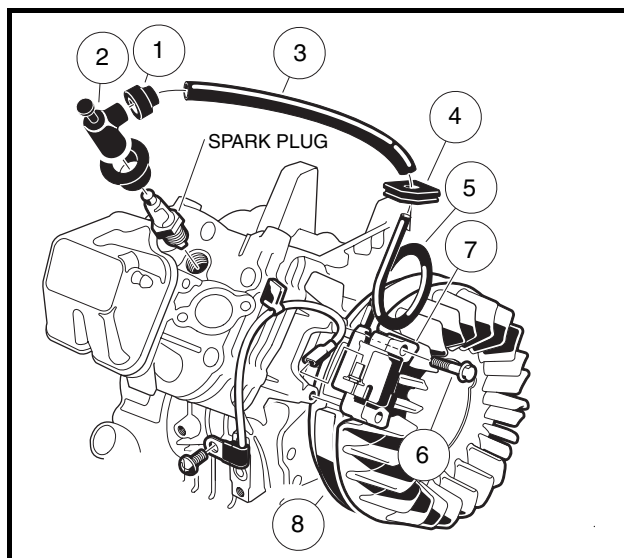

Figure 13-26 Clean Grommet

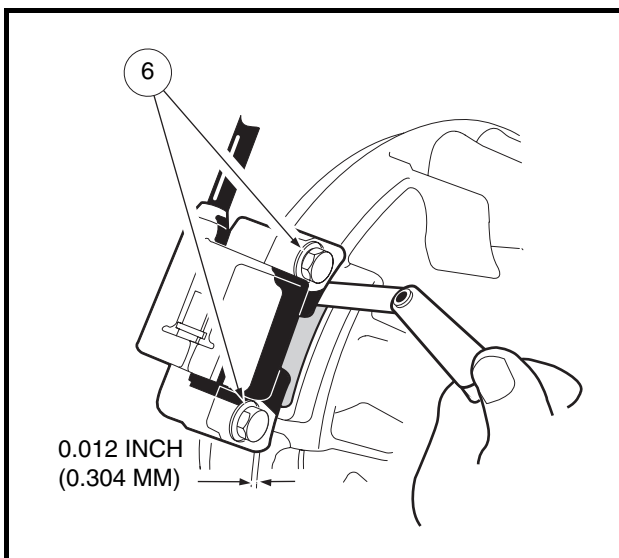

Figure 13-27 Mount Ignition Coil Using Feeler Gauge

21. Install the starter/generator and belt. **See Starter/Generator Installation on page 13-9.**
22. Connect the spark plug wire to the spark plug.
23. Connect the battery cables, positive (+) cable first, and tighten the terminals to 144 in-lb (16.3 N·m). Coat terminals with Battery Terminal Protector Spray (CCI P/N 1014305).

OIL LEVEL SENSOR

See General Warning on page 1-1.

Testing the Oil Level Sensor

See Test Procedure 21, Section 11, Page 11-30.

Oil Level Sensor Removal

See Oil Level Sensor Removal on page 15-5.

Oil Level Sensor Installation

See Oil Level Sensor Installation on page 15-5.

HEADLIGHTS

See General Warning on page 1-1.

Testing the Headlight Socket

See Test Procedure 30, Section 11, Page 11-37.

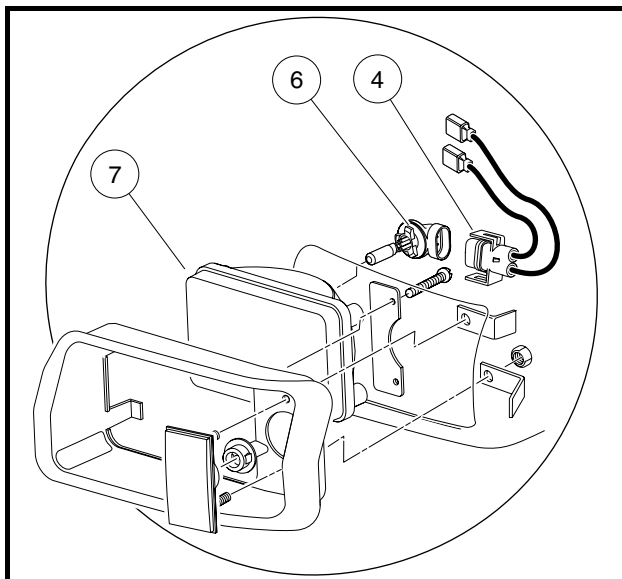

Figure 13-28 Headlight Assembly

Headlight Bulb Removal

1. Turn the key switch OFF and remove the key. Place the Forward/Reverse handle in the NEUTRAL position. Chock the wheels.
2. Disconnect the battery cables as instructed. See **WARNING "To avoid unintentionally starting..." in General Warning on page 1-2.**
3. From the front of vehicle, reach under body and turn the wire harness/halogen bulb assembly (4 and 6) clockwise one-quarter turn (**Figure 13-28, Page 13-27**).
4. Remove the wire harness/halogen bulb assembly (4 and 6) from the headlight lens (7).
5. Lift the retaining tabs on the connector (4) and remove halogen bulb assembly (6).

Headlight Bulb Installation

NOTE: When handling halogen bulbs, do not touch glass portion of bulb. Oil from finger tips can cause premature failure of bulb.

1. Connect wire harness (4) to the halogen bulb assembly (6). The retaining tab should lock onto the halogen bulb assembly (**Figure 13-28, Page 13-27**).
2. From the front of vehicle, reach under body and insert wire harness/halogen bulb assembly (4 and 6) into the headlight lens (7).
3. Turn the wire harness/halogen bulb assembly (4 and 6) counterclockwise one-quarter turn.
4. Connect the battery cables, positive (+) cable first, and tighten the terminals to 144 in-lb (16.3 N·m). Coat terminals with Battery Terminal Protector Spray (CCI P/N 1014305).

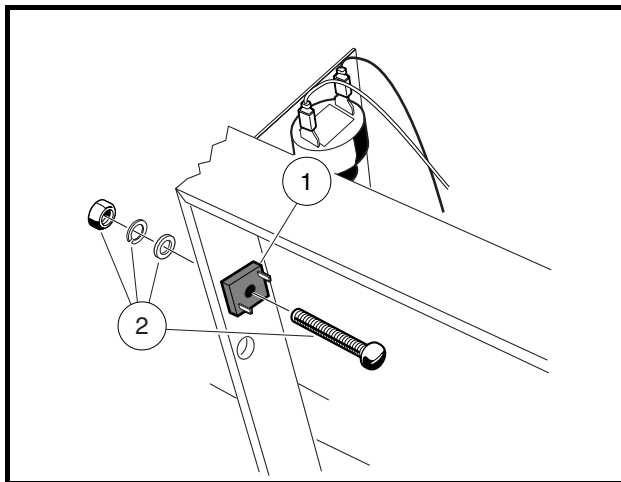

Figure 13-29 Voltage Limiter

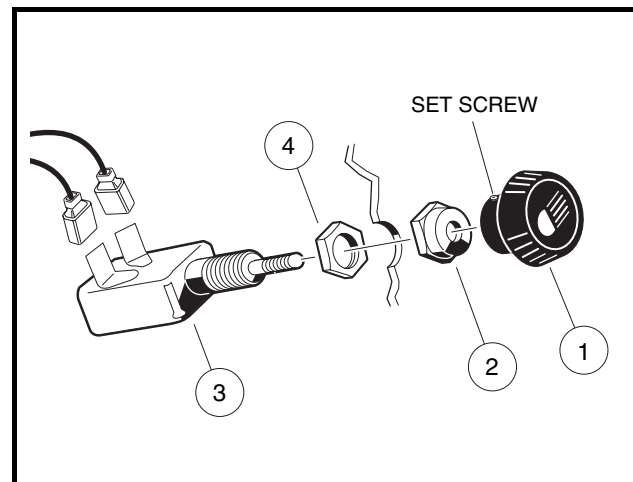

Figure 13-30 Light Switch

VOLTAGE LIMITER

See **General Warning** on page 1-1.

Testing the Voltage Limiter

See **Test Procedure 29, Section 11, Page 11-37**.

Voltage Limiter Removal

1. Turn the key switch OFF and remove the key. Place the Forward/Reverse handle in the NEUTRAL position. Chock the wheels.
2. Disconnect the battery cables as instructed. See **WARNING "To avoid unintentionally starting..."** in **General Warning** on page 1-2.
3. Remove the instrument panel. See **Key Switch Removal** on page 13-14.
4. Disconnect wires from the voltage limiter (1). Do not allow wires to touch (**Figure 13-29, Page 13-28**).

NOTE: Identify terminal for solid black wire and terminal for black/white wire.

5. Remove the mounting hardware (2) from the voltage limiter and remove it from the vehicle.

Voltage Limiter Installation

1. Mount the voltage limiter to the frame using the mounting hardware and tighten to 25 in-lb (2.8 N·m) (**Figure 13-29, Page 13-28**).
2. Connect the black/white wire from harness to the negative (–) terminal on the diode.
3. Connect the solid black wire from the ground terminal block to the positive (+) terminal on the diode.
4. Install the instrument panel in reverse order of removal. **See Key Switch Removal on page 13-14.**
5. Connect the battery cables, positive (+) cable first, and tighten the terminals to 144 in-lb (16.3 N·m). Coat terminals with Battery Terminal Protector Spray (CCI P/N 1014305).

LIGHT SWITCH

See General Warning on page 1-1.

Testing the Light Switch

See Test Procedure 28, Section 11, Page 11-36.

Light Switch Removal

1. Turn the key switch OFF and remove the key. Place the Forward/Reverse handle in the NEUTRAL position. Chock the wheels.
2. Disconnect the battery cables as instructed. **See WARNING “To avoid unintentionally starting...” in General Warning on page 1-2.**
3. Loosen the set screw locking the light switch knob (1) to the shaft (**Figure 13-30, Page 13-28**).
4. Remove the instrument panel. **See Key Switch Removal on page 13-14.**
5. Disconnect the wires from the light switch.
6. Remove the outer nut (2) from the light switch (3) and remove.

Light Switch installation

1. Connect the wires to the light switch. **See Wiring Diagrams, Section 11, Page 11-6.**
2. Thread the check nut (4) onto the switch until an equal number of threads show on both sides. Install to the instrument panel with nut (2) on the outside of the dash and tighten the nut to 14 in-lb (1.6 N·m) (**Figure 13-30, Page 13-28**).
3. Push the light switch shaft in. Screw the knob onto the end of the shaft until the knob touches the outer nut. Then turn the knob in the opposite direction until the headlight beams on the knob are horizontal to the ground. Tighten the set screw to lock the knob to the shaft.
4. Install the instrument panel in reverse order of removal. **See Key Switch Removal on page 13-14.**
5. Connect the battery cables, positive (+) cable first, and tighten the terminals to 144 in-lb (16.3 N·m). Coat terminals with Battery Terminal Protector Spray (CCI P/N 1014305).

BATTERY

See General Warning on page 1-1.

⚠ DANGER

- Due to the danger of an exploding battery, wear a full face shield and rubber gloves when working on or near batteries.
- Battery – Explosive gases! Do not smoke. Keep sparks and flames away from the vehicle and service area. Ventilate when charging or operating vehicle in an enclosed area. Wear a full face shield and rubber gloves when working on or near batteries.
- Tools, wires, and metal objects can cause sparks when shorted across a battery.
- Follow all instructions carefully when working with batteries.
- Charge battery in a well-ventilated area only.
- Battery – Poison! Contains acid! Causes severe burns. Avoid contact with skin, eyes, or clothing. Antidotes:
 - External: Flush with water. Call a physician immediately.
 - Internal: Drink large quantities of milk or water followed with milk of magnesia or vegetable oil. Call a physician immediately.
 - Eyes: Flush with water for 15 minutes. Call a physician immediately.

⚠ WARNING

- Do not jump start a dead battery using another battery and jumper cables.

General Information

See preceding DANGER and WARNING statements.

Gasoline vehicles are equipped with 12-volt, low-maintenance batteries that requires infrequent watering. When changing a 12-volt battery in any gasoline-powered vehicle, the same size battery with adequate amperage ratings should be used as a replacement.

A group 70, side-post battery (CCI P/N 1012328), with a 650 cranking amp rating at 32 °F (0 °C) (500 CCA at 0 °F (-17.8 °C)) and a reserve capacity of at least 105 minutes is recommended. The group 70 classification indicates battery size: 8-1/4 inches W x 6-1/2 inches D x 7-1/4 inches H (21.0 cm W x 16.5 cm D x 18.4 cm H). It is important to use the proper size to ensure that the battery clamp will fit correctly.

Testing the Battery

See Test Procedure 1 – Battery on page 11-9.

See Test Procedure 24 – Battery Test (Under Load) on page 11-31..

Preventive Maintenance

1. To keep the battery in good operating condition, remove any corrosion immediately. Post connections should be clean and tight. Any frayed or worn wires should be replaced. After all cables have been connected and properly tightened to 144 in-lb (16 N·m), coat terminals with Battery Terminal Protector Spray (CCI P/N 1014305) to prevent future corrosion. **See preceding WARNINGS and following CAUTION.**

⚠ CAUTION

- If battery wire terminals are damaged or corroded, replace or clean them as necessary. Failure to do so may cause them to overheat during operation and could result in a fire, property damage, or personal injury.
2. The battery should be kept clean and dry to prevent self-discharge. Any dirt, grime or acid spillage should be removed. Wash the battery with a bristle brush using water and bicarbonate of soda (1 cup (237 mL) baking soda per 1 gallon (3.8 L) of water). Rinse with water. Do not allow solution to enter battery through the vent cap holes. **See Self-Discharge on page 13-31.**
 3. Maintain proper water level. **See Water Level on page 13-31.**
 4. Check battery periodically to see that it is in a full state of charge. **See Charging the Battery on page 13-33.**
 5. Keep battery hold-down clamp tight. **See Vibration Damage on page 13-32.**

Self-Discharge

Dirt and battery acid can provide a path for a small current draw that slowly discharges the battery. To prevent self-discharge, the battery should always be kept clean.

Hot weather also has an effect on a battery's self-discharge rate. The higher the temperature, the quicker a battery will discharge. In hotter climates, therefore, the battery should be checked more often. When storing the battery, keep in a cool place. **See Battery Storage on page 13-33.**

Water Level

The water level should be checked semi-annually to be sure water is at its proper level (**Figure 13-31, Page 13-31**). Never allow the water level to fall below the tops of the plates because this will cause the exposed part of the plate to become permanently inactive. Check the water level more frequently in hot weather or when the battery becomes old.

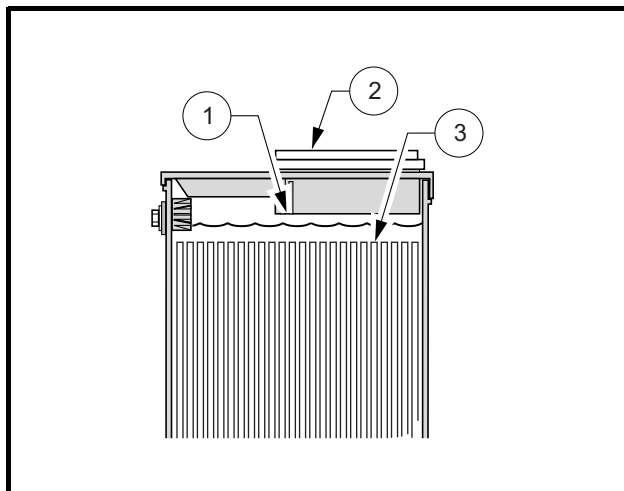

Figure 13-31 Battery Electrolyte Level

1. Level Indicator 2. Cap 3. Plates
Electrolyte level at least 1/2 inch (13 MM) above plates or to level indicator.

Vibration Damage

The battery hold-down clamp should always be tight enough to keep the battery from bouncing. Battery life may be severely shortened if the clamp is too loose. Excessive vibration shortens the life of the battery. It may also cause acid to leak out of the vent caps and corrosion to build up on surrounding metal parts. The acid that is lost reduces the capacity of the battery and cannot be replaced.

Mineral Content

For the longest battery life, distilled water should be used in the battery. However, if tap water is going to be used, contact your local water department to be sure mineral contents are below the levels listed in the following table. **See following NOTE.**

NOTE: Contact your local water department for mineral content analysis.

IMPURITY	ALLOWABLE CONTENT (PARTS PER MILLION)
Suspended matter	Trace
Total solids	100.0
Calcium and Magnesium Oxides	40.0
Iron	5.0
Ammonia	8.0
Organic matter	50.0
Nitrates	10.0
Nitrites	5.0
Chloride	5.0

Battery Removal

See General Warning on page 1-1 and DANGER on page 13-30.

1. Turn the key switch OFF and remove the key. Place the Forward/Reverse handle in the NEUTRAL position. Chock the wheels.
2. Disconnect the battery cables as instructed. **See WARNING “To avoid unintentionally starting...” in General Warning on page 1-2.**
3. Remove the battery hold-down clamp from the battery.
4. Lift the battery from the vehicle. **See following WARNING.**

WARNING

- **Keep the battery in an upright position to prevent electrolyte leakage. Tipping the battery beyond a 45° angle in any direction can allow a small amount of electrolyte to leak out of the vent hole. Do not exceed this 45° angle when lifting, carrying or installing battery. The battery acid could cause severe personal injury when accidentally coming in contact with the skin or eyes, and could damage clothing.**

Charging the Battery

See **General Warning** on page 1-1 and **DANGER** on page 13-30.

1. Charge the battery using an automotive type 12-volt battery charger. Follow all warnings and procedures supplied by the battery charger manufacturer.
2. Attach the positive (+) charger cable to the positive (+) battery post.
3. Attach the negative (–) charger cable to the negative (–) battery post.
4. The battery may be charged with a slow charge (3-10 amps) or a fast charge (20-30 amps). Charge until the specific gravity reaches 1.250. **See following WARNING.**

⚠ WARNING

- If the battery case feels hot (approximately 125 °F (52 °C) or more), emits gases, or fluid boils from vents, stop charging immediately. Failure to stop charging battery when any of these conditions are present could result in an explosion, personal injury and/or damage to the battery.
- Do not disconnect the charger DC leads from the battery when the charger is on. The resulting arcing between the DC leads and battery post could cause an explosion.
- If the charger must be stopped, disconnect the AC supply cord from the wall outlet before disconnecting the DC leads from the battery. Allow the battery to cool to room temperature and resume charging battery at a lower amp rate.

Battery Installation

See **General Warning** on page 1-1 and **DANGER** on page 13-30.

1. Place the battery into the vehicle with the battery posts facing the engine.
2. Secure the battery to the vehicle with the clamp and install bolt, washer and locknut and tighten to 144 in-lb (16.3 N·m). A loose battery clamp may allow the battery to become damaged from vibration or jarring.
3. Connect the battery cables, positive (+) cable first, and tighten the terminals to 144 in-lb (16.3 N·m) (**Figure 1-1, Page 1-3**). Coat terminals with Battery Terminal Protector Spray (CCI P/N 1014305).

Battery Storage

See **General Warning** on page 1-1 and **DANGER** on page 13-30.

1. Keep the battery clean and free of corrosion. **See Preventive Maintenance** on page 13-30.
2. The battery cables should be disconnected from the battery so the battery can be connected to the charger. The battery can be left in the vehicle. Disconnect the negative (–) cable first. **See WARNING “To avoid unintentionally starting...”** in **General Warning** on page 1-2.
3. Fully charge the battery prior to storage.
4. Store in a cool, dry area. The colder the area in which the battery is stored, the less the battery will self-discharge. A battery stored at 0 °F (-17.8 °C) will discharge very little over a four-month period. A battery stored at 80 °F (27 °C) will have to be recharged every few weeks.
5. Check the state of charge periodically. A battery that is discharged and left in a cold environment can freeze and crack. If the specific gravity drops below 1.220, the battery should be recharged. **See following WARNING.**

 WARNING

- If the battery is frozen or the container is bulged, discard battery. A frozen battery can explode.
6. The frequency of recharging required depends on the temperature of the storage area, but it is recommended that the battery be monitored for state of charge every month. Also, if the storage area is unheated in a cold climate and recharging is required, it is recommended that the area be heated to at least 60 °F (16 °C) prior to charging. The battery will not charge effectively in cold temperatures for the same reasons that it does not discharge as rapidly in cold temperatures.

Charging a Dead Battery

See General Warning on page 1-1 and DANGER on page 13-30.

The vehicle is equipped with a starter/generator. The generator is not designed to charge a dead battery. If the vehicle battery has become discharged, it must be charged using a properly rated automotive type charger. See following **WARNING**.

 WARNING

- Do not jump-start a dead battery using another battery and jumper cables.

GROUND CABLES**Testing the Ground Cables**

See Test Procedure 3, Section 11, Page 11-12.

SECTION 14 – ELECTRICAL COMPONENTS: 850 GASOLINE VEHICLE

⚠ DANGER

- See General Warning on page 1-1.

⚠ WARNING

- See General Warning on page 1-1.

STARTER/GENERATOR

See General Warning on page 1-1.

Testing the Starter/Generator

See Test Procedure 8 – Starter/Generator (Starter Function) on page 12-16.

See Test Procedure 10 – Starter/Generator (Generator Function) on page 12-18.

Starter/Generator Removal

1. Disconnect battery cables as instructed. See **WARNING** “To avoid unintentionally starting...” in General Warning on page 1-2.
2. Place the neutral lockout switch in the MAINTENANCE position. Access the engine compartment by removing the seat. See Section 4 – Body and Trim.
3. Disconnect the wires from the starter/generator (1). Mark wires before disconnecting. Loosen the pivot nuts (7) and bolts (5) (Figure 14-1, Page 14-1).
4. Remove the mounting/adjustment nut (12), washer (9) and bolt (11). Lower the starter/generator and remove the belt (4) from the pulley (10).

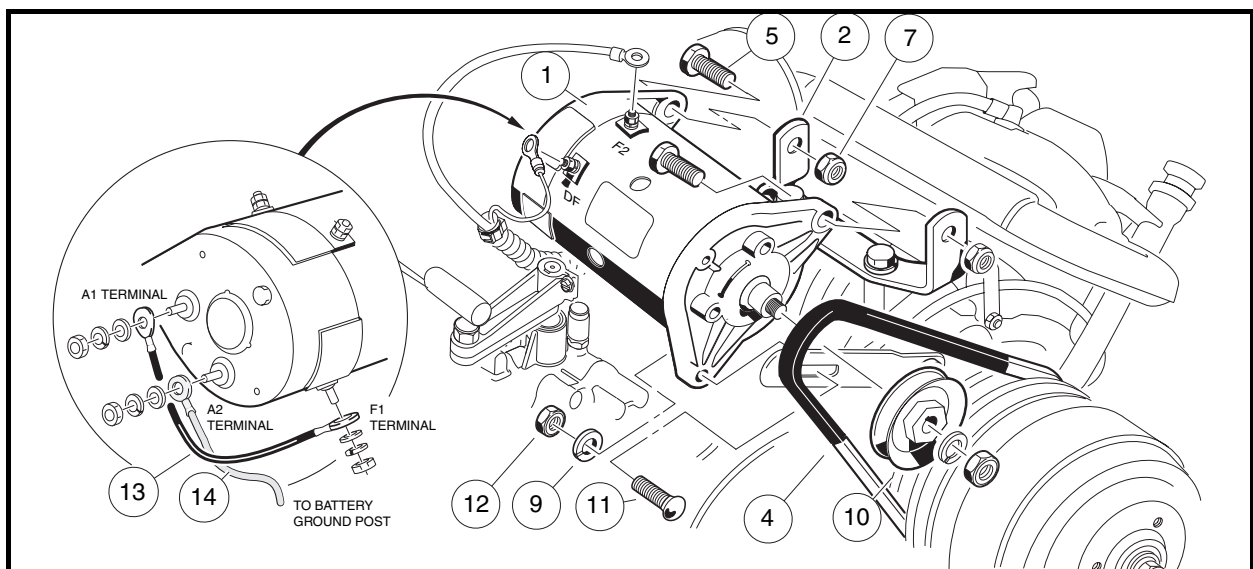

Figure 14-1 Starter/Generator Removal

- Support the starter/generator so that when the pivot bolts are removed the starter/generator will not fall to the ground. Remove the two pivot nuts (7) and bolts (5) from the mounting bracket.
- Remove the starter/generator.

Disassembly of the Starter/Generator to Service the Brushes

- Remove the two bolts (20) and pull commutator end cover (23) free of starter/generator housing (24) (Figure 14-2, Page 14-2). See following NOTE.

NOTE: If the brushes are not removed, contact between the brushes and commutator as the commutator end cover is being removed or installed could damage the brushes. Lift the brush springs out of the notches in the brushes and pull the brushes back from the center of the commutator end cover. The springs will rest on the sides of the brushes and help prevent them from sliding towards the center of the cover (Figure 14-6, Page 14-4).

- Remove brush covers (29 and 30), screws (25) and lock washers (26), brush springs (28), and brushes (27) (Figure 14-3, Page 14-2). See following NOTE.

NOTE: To clean and inspect the armature/commutator and the bearings, see Disassembly of the Starter/Generator to Service the Armature/Commutator on page 14-4.

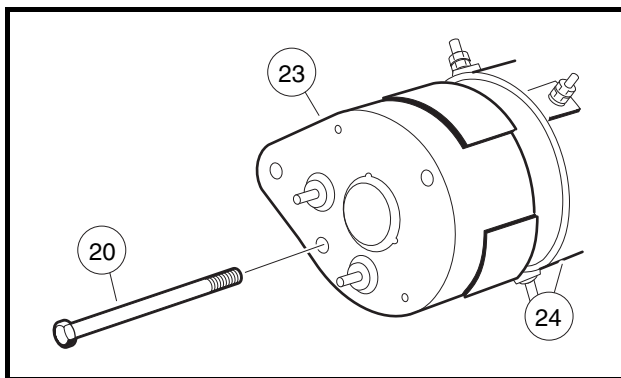

Figure 14-2 Commutator End Cover

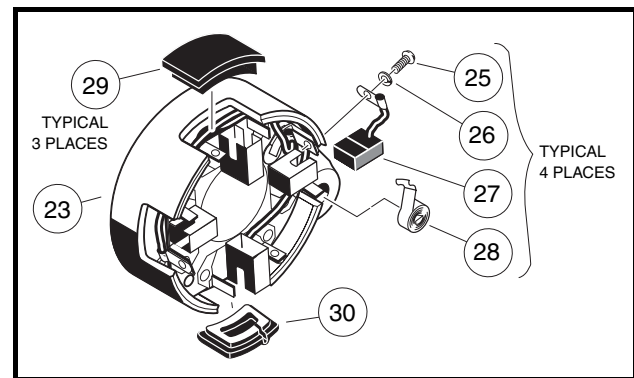

Figure 14-3 Brush Covers and Brushes

Brush Inspection and Replacement

- Visually inspect brushes. Replace brushes that are cracked or severely chipped.
- Check the wear line on the side of the brush. If the end of the brush is within 1/16 inch (1.6 mm) of the wear line, replace all four brushes (Figure 14-4, Page 14-2).

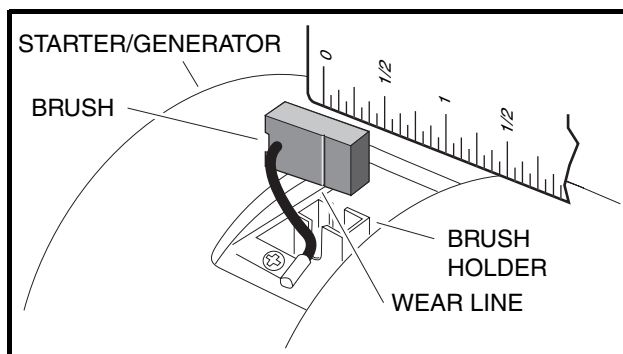

Figure 14-4 Inspect Brushes

Brush Spring Inspection and Replacement

1. Visually inspect springs. Replace all four springs if any spring is discolored from heat (straw or bluish in color).
2. Install the four brushes (27) into their holders and insert the four brush springs (28) (**Figure 14-3, Page 14-2**). Using a spring scale, test brush spring tension. If any spring has a tension less than 24 ounces (6.67 N), replace all four springs (**Figure 14-5, Page 14-3**). **See following CAUTION.**

⚠ CAUTION

- When checking brush spring tension, do not push springs beyond the point they would normally be if there were new brushes installed. Exerting excessive force or pushing brush springs beyond their normal maximum extension point will damage springs.

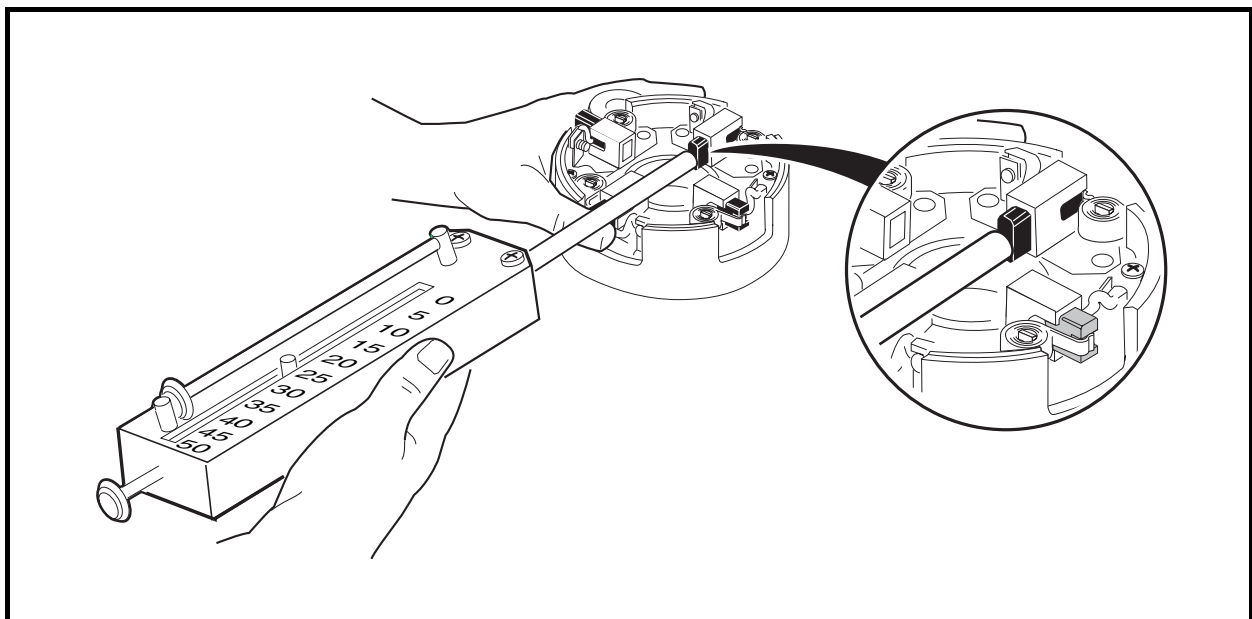

Figure 14-5 Brush Spring Tension Test

Starter/Generator Assembly

1. Connect the brush wires to the holders using four lock washers (26) and four screws (25), making sure the crossover leads are connected also. Tighten the screws to 31 in-lb (3.5 N·m) (**Figure 14-3, Page 14-2**).
2. To prevent contact between the brushes and commutator as the commutator is installed, and possible damage to the brushes, lift the brush springs out of the notches in the brushes and pull the brushes back from the center of the commutator end cover. The springs will rest on the sides of the brushes and help prevent them from sliding towards the center of the cover (**Figure 14-6, Page 14-4**).
3. Install the commutator end cover (23) onto the armature shaft. Align the locating pin with the pin hole in the cover. Install two M6 x 180 mm bolts (20) and tighten to 100 in-lb (11.3 N·m) (**Figure 14-2, Page 14-2**).
4. Push the brushes down into the holders. Position springs into the notches in the brushes. Install the brush cover (30) that has the drain hole in it next to the A2 terminal. Install the remaining three brush covers (29) in the openings in the commutator end cover (23) (**Figure 14-3, Page 14-2**).

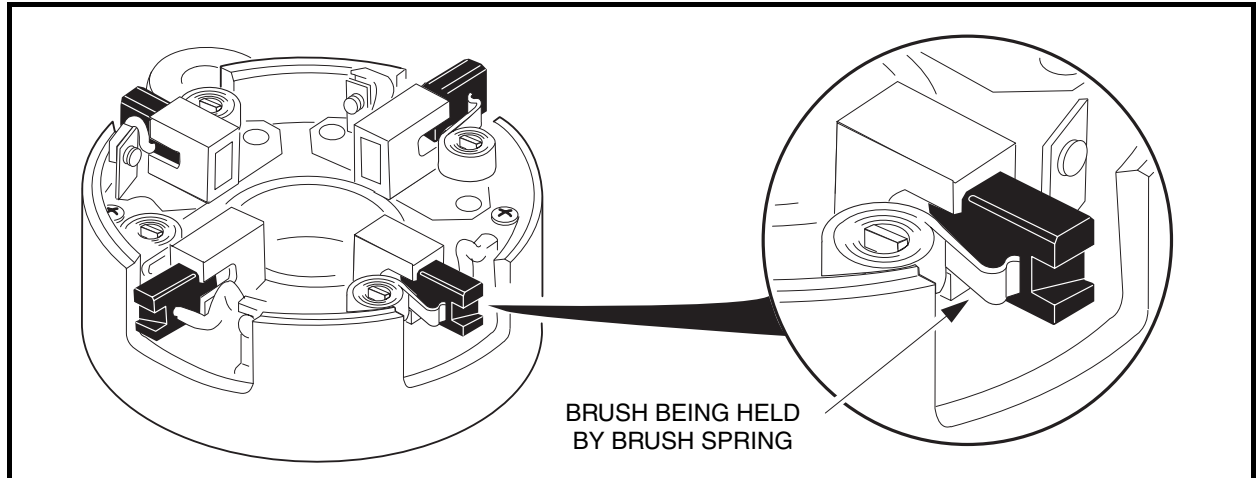

Figure 14-6 Pull Brushes Away From Center of the Commutator End Cover

Disassembly of the Starter/Generator to Service the Armature/Commutator

1. If the brushes are not removed, contact between the brushes and commutator as the commutator end cover is being removed or installed could damage the brushes.
 - 1.1. Lift the brush springs out of the notches in the brushes and pull the brushes back from the center of the commutator end cover. The springs will rest on the sides of the brushes and help prevent them from sliding towards the center of the cover (Figure 14-6, Page 14-4).
2. Remove the two bolts (20), and pull commutator end cover (23) free of the starter/generator housing (24) (Figure 14-2, Page 14-2).
3. To separate armature (33) from output end cover (36), remove nut (41), lock washer (40), pulley (39), shaft key (34), spacer (37), and bearing retainer screws (43) (Figure 14-7, Page 14-4).

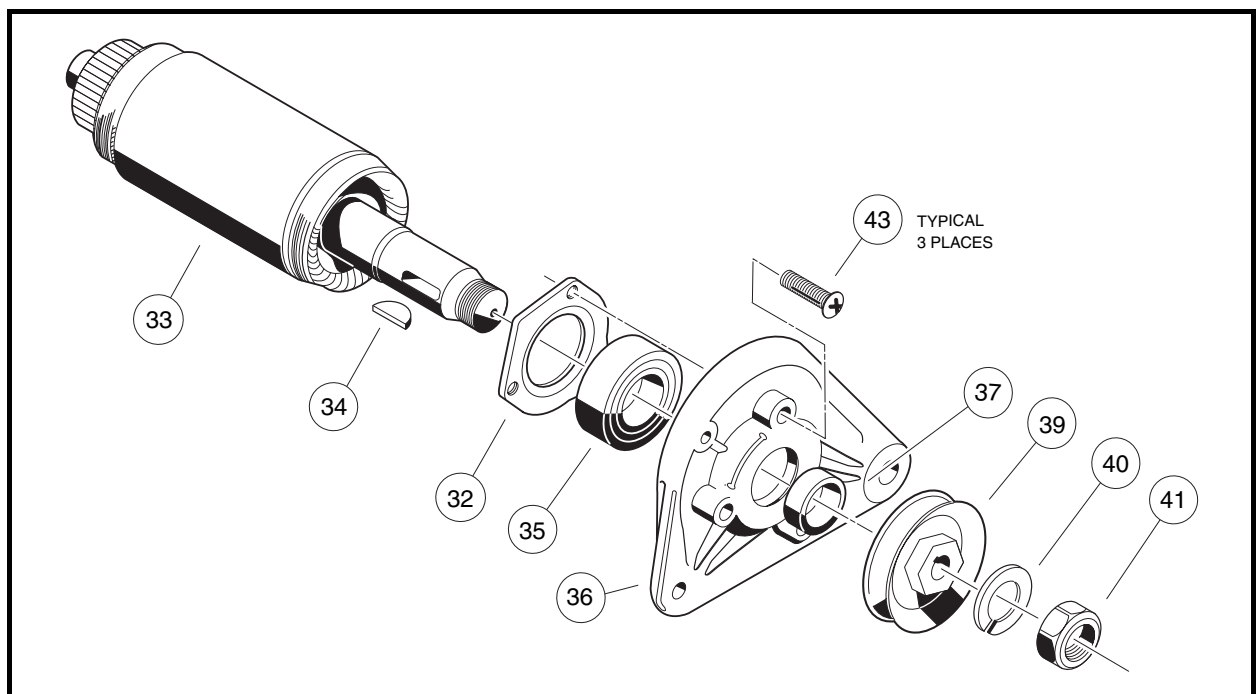

Figure 14-7 Armature and Output End Cover Assembly

Bearing Cleaning and Inspection

1. Using a clean cloth, wipe the carbon dust from the two bearings. Inspect bearings by spinning them by hand and checking for both axial (A) and radial (B) play (**Figure 14-8, Page 14-5**).
2. Replace the bearing if it is noisy, does not spin smoothly, or has excessive play. Check the bearings and replace if rusted, worn, cracked, or if there is an abnormal color change in the metal of the bearing. Bearings should be replaced if there is extensive wear or pitting on the balls or on the rolling surfaces. Do not remove the bearings unless they are to be replaced.

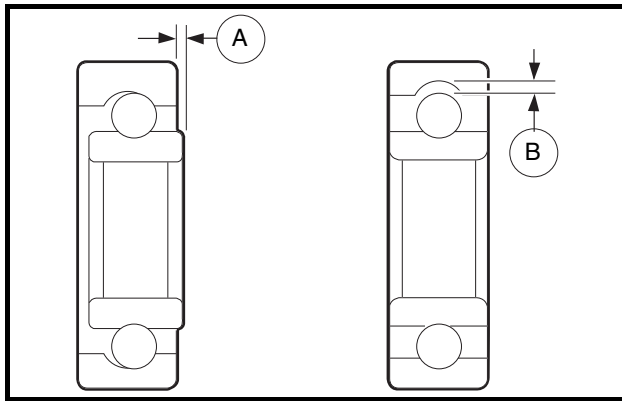

Figure 14-8 Bearing Play Inspection

Bearing Removal

1. Place the wedge attachment tool (CCI P/N 1012812) between the bearing and the armature. Make sure the wedge attachment tool is supporting the inner race of the bearing. If a press is not available, secure a bearing puller (CCI P/N 1012811) to the wedge attachment tool and pull the bearing off of the end of the armature shaft. Support the armature so that it will not drop when the bearing is removed (**Figure 14-9, Page 14-5**).
2. Discard the bearings.
3. Slide the bearing retainer (32) off of the output end of the shaft (**Figure 14-7, Page 14-4**).

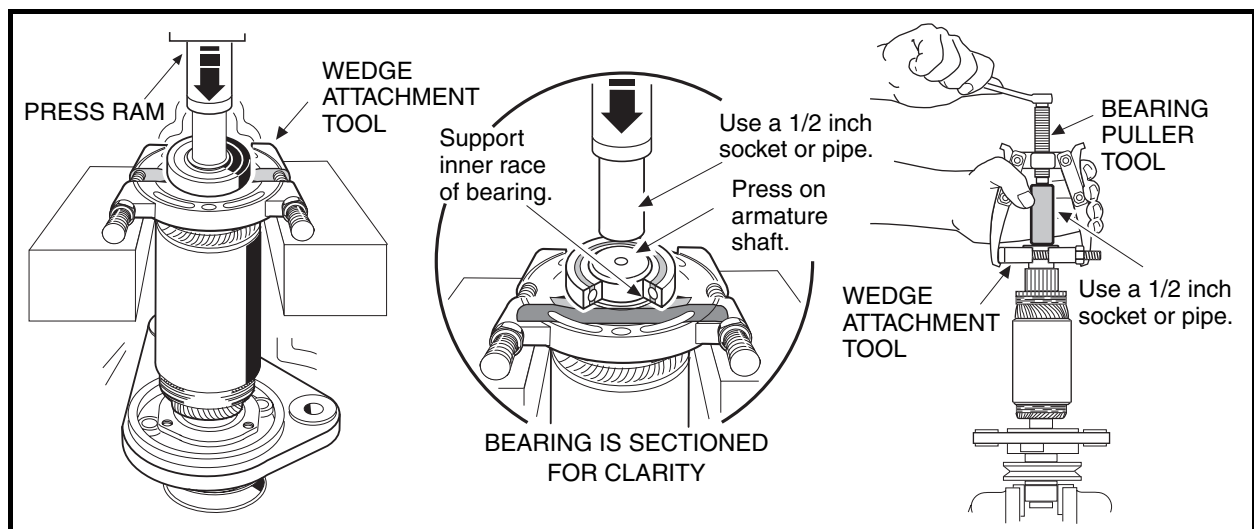

Figure 14-9 Bearing Removal

Field Coil Removal

1. Remove the retaining nut from each field coil terminal and slide the insulator out of the slots in the housing. Remove the four pole piece screws from the housing. Remove the four pole pieces from inside the housing. Remove the field coils from the inside of the housing (**Figure 14-10, Page 14-6**). See following **NOTE**.

NOTE: Do not remove the insulators or the field coils unless an electrical test indicates that it is necessary (**Figure 14-10, Page 14-6**). See **Test Procedure 8 – Starter/Generator (Starter Function)** on page 12-16.

Visual Inspection of Armature

Obvious defects can be seen by examining the armature. If an armature has frayed or charred insulation, broken wires or thrown solder, it is obvious without testing that it should be replaced. Faults seen during the visual inspection can aid in diagnosing the original cause of the failure. Items to look for are listed below.

- Burned, charred, or cracked insulation
- Improperly cured varnish
- Thrown solder
- Flared armature windings
- Worn, burned, or glazed commutator
- Loose or raised commutator bars
- Bruised or damaged armature core laminations
- Worn armature bearing or shaft
- Dirty or oily commutator

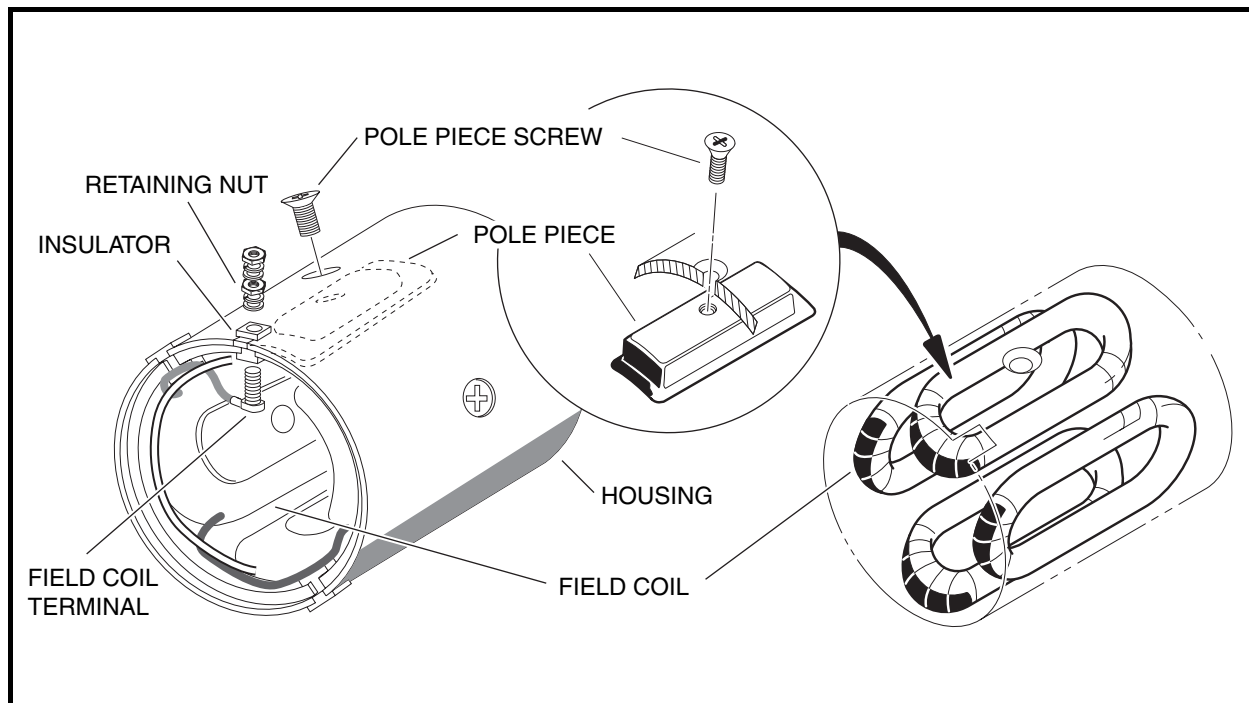

Figure 14-10 Field Coil Assembly

Commutator Cleaning and Inspection

1. Clean the carbon dust, dirt and oil from the commutator. Visually inspect the commutator for worn, burned or glazed areas. Check for loose or raised commutator bars. Slight roughness of the commutator can be polished away with 400 grit (or finer) sandpaper. **See following CAUTION.**

⚠ CAUTION

- Do not use emery cloth on the commutator. Particles of emery are conductive and may short-circuit the commutator bars. Do not use oil or lubricants on the commutator or brushes.

2. Using a micrometer, measure the outside diameter at two points along the commutator. If the commutator outside diameter is less than 1.535 inches (39 mm), replace the armature and bearings (Figure 14-11, Page 14-7).

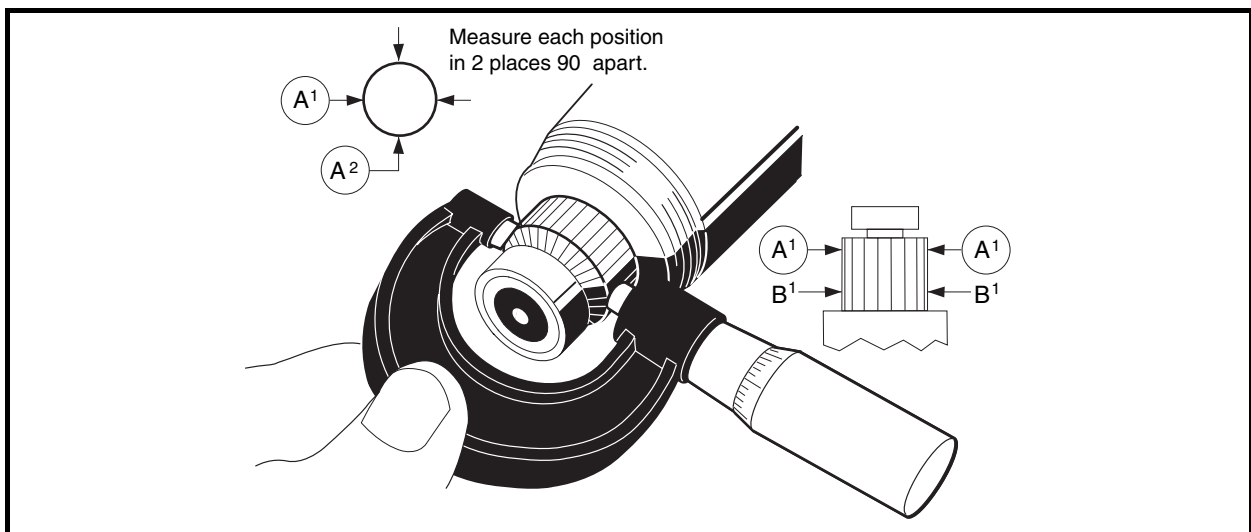

Figure 14-11 Inspect Commutator

Armature Ground Test

⚠ CAUTION

- Do not submerge armature in solvent.

NOTE: Before testing, wipe the armature with a clean cloth and remove carbon dust and metal particles from between commutator bars.

1. Using a multimeter set on 200 ohms, place the positive (+) probe on the commutator bars and the negative (–) probe on the armature core. The reading should be no continuity. If the reading is incorrect, replace the armature and the two bearings (Figure 14-12, Page 14-8).

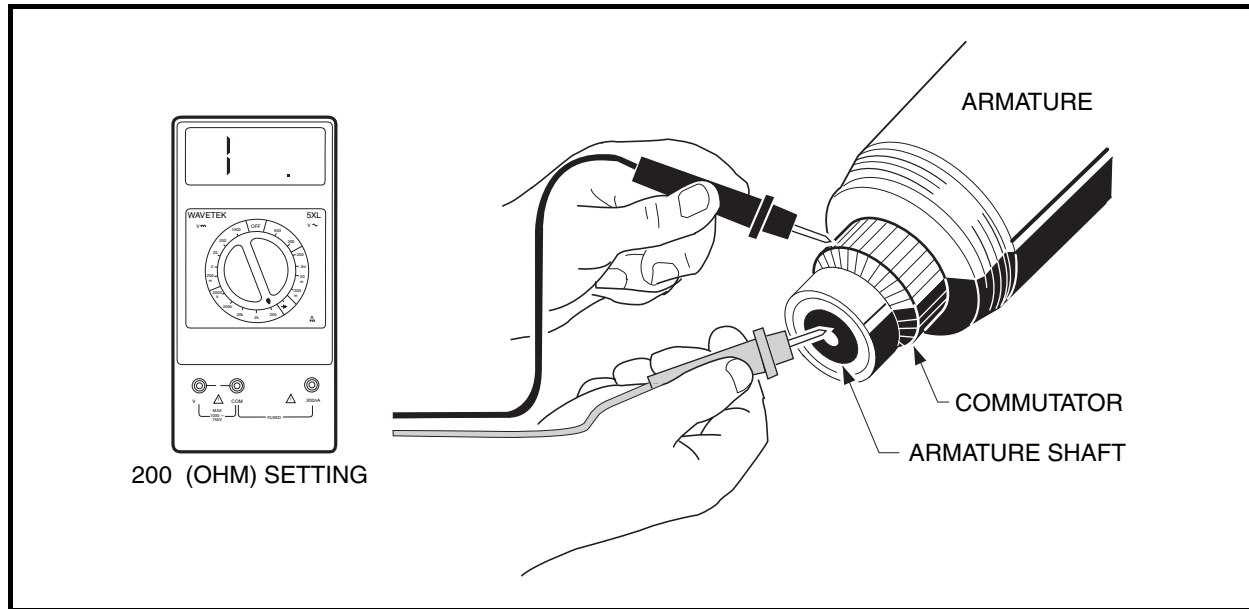

Figure 14-12 Armature Ground Test

Visual Inspection of Field Coils

If the insulation on the field coils appears blackened or charred, the serviceability of the coils is questionable. Burned or scorched coil insulation indicates the starter/generator has overheated due to overloads or grounded or shorted coil windings. Be sure the insulators are tight in the housing.

Starter/Generator Rework

Any rework must be performed by a qualified technician. Starter/Generator service specifications are listed in the following table.

ITEM	SERVICE LIMIT
Commutator diameter (minimum)	1.535 in. (39 mm)
Concentric with armature shaft within	0.002 in. (0.051 mm)
Limit depth of cut when machining commutator	0.007 in. (0.2 mm)
If undercut of segment insulator is less than 0.016 inch (0.406 mm), then it should be undercut to:	0.031 in. (0.8 mm)
Dielectric strength	500 VAC for one minute
Armature insulation resistance	0.2M ohms at 500 VDC
Starter field coil resistance	0.006-0.01 ohms
Generator field coil resistance	4.5-5.5 ohms

Starter/Generator Assembly

1. Place the field coil into the housing. The two insulators that look alike fit into the slots next to the F1 and F2 markings on the outside of the housing. The insulator that looks different slides into the slot next to the DF marking.
2. After the insulators are seated in the slots, install the threaded terminals through the wire connectors and then through the insulators. Install a flat washer, lock washer and nut onto each threaded terminal on the outside of the housing. Tighten nuts to 47.5 in-lb (5.4 N·m) (**Figure 14-10, Page 14-6**).

⚠ CAUTION

- **Route the field terminal wires so that they will not contact the armature.**

3. Install the four pole pieces into the housing. Use the four screws to secure pole pieces to the inside of the housing to retain the field wires. Tighten screws to 9 ft-lb (12.2 N·m) (**Figure 14-10, Page 14-6**).
4. Slide the bearing retainer onto the output end of the armature shaft (33) so that it will hold the outside of the bearing (35) only.
5. Press a new ball bearing (35) onto the output end of the armature (**Figure 14-7, Page 14-4**). Press a new ball bearing onto the commutator end of the armature shaft. **See following CAUTION.**

⚠ CAUTION

- **To prevent damage to the retainer, use care while pressing new bearing onto the output end of the shaft.**
- **Press against the inner race of the new bearing until it is fully seated.**

6. Install the output end cover (36) onto the armature. Secure the bearing retainer (32) to the cover and tighten the screws (43) to 39 in-lb (4.4 N·m) (**Figure 14-7, Page 14-4**).
7. Slide the housing with field coils over the armature. Use the locating pin to align housing to the cover.

NOTE: *The terminal insulators should be on the commutator end of the housing.*

8. To prevent contact between the brushes and commutator as the commutator cover is installed, and possible damage to the brushes, lift the brush springs out of the notches in the brushes and pull the brushes back from the center of the commutator end cover. The springs will rest on the sides of the brushes and help prevent them from sliding towards the center of the cover (**Figure 14-6, Page 14-4**).
9. Install the commutator end cover (23) onto the armature shaft. Align the locating pin with the pin hole in the cover. Install the two M6 x 180 mm bolts (20), and tighten to 100 in-lb (11.3 N·m) (**Figure 14-2, Page 14-2**).
10. Push the brushes down into the holders. Place springs into the notches in the brushes. Install the brush cover (30) that has the drain hole in it next to the A2 terminal. Install the remaining three brush covers (29) in the openings in the commutator end cover (23) (**Figure 14-3, Page 14-2**).
11. Slide the spacer (37) onto the end of the shaft. Insert the shaft key (34) into the shaft. Install the belt pulley (39) onto the shaft, and install the lock washer (40) and M14 nut (41). Tighten the nut to 28 ft-lb (38.0 N·m) (**Figure 14-7, Page 14-4**).

Starter/Generator Installation

1. Install the green wire from the F1 terminal to the A1 terminal on the starter/generator (**Figure 14-1, Page 14-1**). Install a flat washer, lock washer, and nut onto each terminal and tighten to 48 in-lb (5.4 N·m).
2. Install two 3/8-inch hex-head pivot bolts (5) into the mounting bracket with the heads of the bolts facing toward the driver-side of the vehicle. Position the starter/generator in the mounting bracket so that the bolts will go through the starter/generator before going through the bracket. Install a lock nut (7) onto each bolt. Tighten to finger tight (**Figure 14-13, Page 14-10**).
3. Install the adjustment bolt (11) through the adjusting bracket (4) and then through the starter/generator. Install a lock washer (9) and 5/16-inch nut (12) onto the end of the adjustment bolt (11). Tighten to finger tight (**Figure 14-13, Page 14-10**).
4. Install the belt (3), then tighten the mounting bolts. **See Belt Tension Adjustment on page 14-11.**
5. Connect the yellow wire from the voltage regulator to the DF terminal on the starter/generator. Install a flat washer, lock washer, and nut onto the terminal. Tighten the nut to 31 in-lb (3.5 N·m).
6. Install the white wire from the solenoid to the F2 terminal on the starter/generator. Install the black wire from the frame to the A2 terminal on the starter/generator. Install a flat washer, lock washer and nut onto each terminal, and tighten the nut to 48 in-lb (5.4 N·m).
7. Connect battery cables, positive (+) cable first, and tighten hardware to 144 in-lb (16 N·m) (**Figure 1-1, Page 1-3**). Coat terminals with Battery Terminal Protector Spray (CCI P/N 1014305) to minimize corrosion.

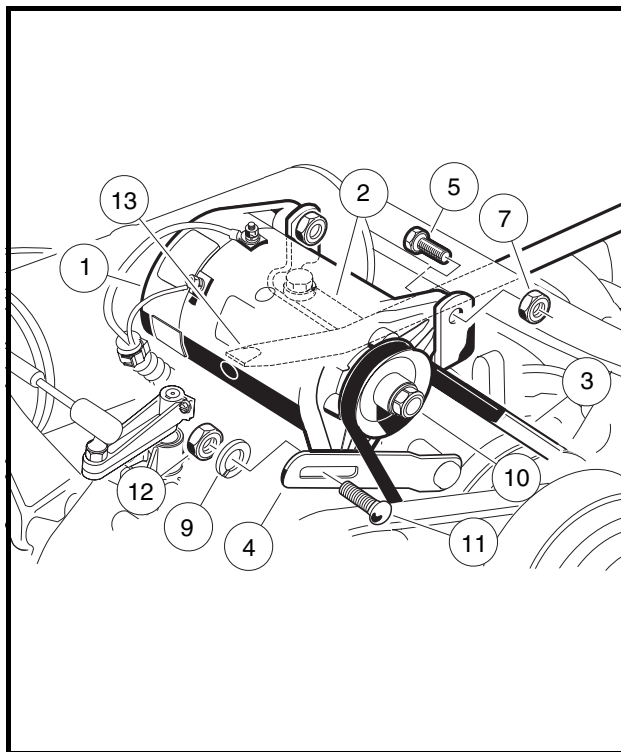

Figure 14-13 Starter/Generator Installation

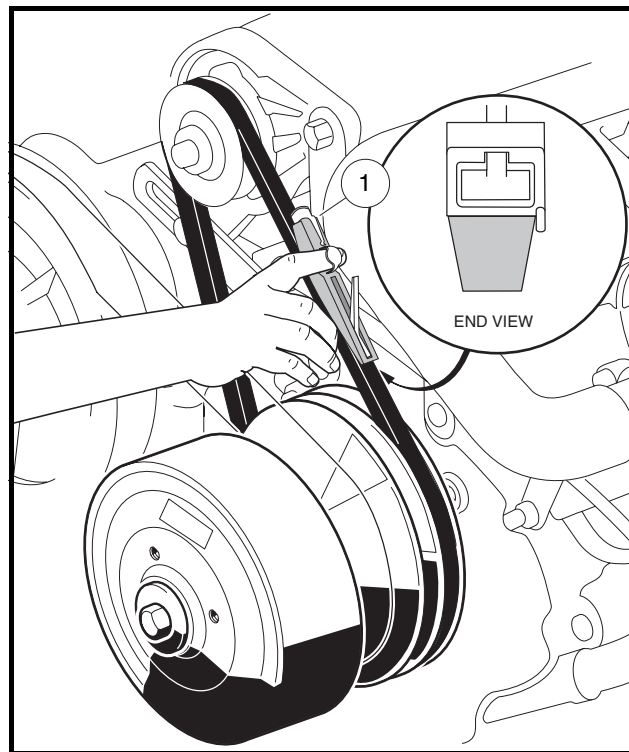

Figure 14-14 Belt Tension Gauge

Belt Tension Adjustment

Belt tension should be checked periodically. If the belt slips when starter/generator motor operates, adjust belt to correct tension.

1. Disconnect battery cables as instructed. **See WARNING “To avoid unintentionally starting...” in General Warning on page 1-2.**
2. Remove the seat to access engine compartment. **See Section 4 – Body and Trim.**
3. Make sure the two pivot bolts (5) on the mounting bracket are finger tight. The carriage bolt (11) and hex nut (12) are to be finger tight also (**Figure 14-13, Page 14-10**).
4. Push the starter/generator down so it is at the lowest point of its adjustment travel. With the starter/generator belt in place around the drive clutch pulley, install the starter/generator belt (3) around the pulley (10) on the end of the starter/generator.
5. Position a pry bar (13) between the top of the starter/generator mounting bracket (2) and the underside of the starter/generator by passing the pry bar under the exhaust header.
6. While holding the pry bar, measure the belt tension using a Krikit[®] gauge (1) (available at NAPA[®] Auto Parts stores), or equivalent. Proper tension for a new starter/generator belt should be 75 ft-lb (101.7 N·m) or 45 ft-lb (61 N·m) for an existing belt (**Figure 14-14, Page 14-10**).
7. While maintaining the tension, tighten the adjustment nut (12) to 144 in-lb (16.3 N·m). Tighten the two pivot bolts (5) and hex nuts (7) to 23 ft-lb (31.2 N·m) (**Figure 14-13, Page 14-10**). **See following CAUTION.**

▲ CAUTION

- Remove pry bar before starting engine.

8. Connect battery cables, positive (+) cable first, and tighten hardware to 144 in-lb (16 N·m) (**Figure 1-1, Page 1-3**). Coat terminals with Battery Terminal Protector Spray (CCI P/N 1014305) to minimize corrosion.

VOLTAGE REGULATOR

See General Warning on page 1-1.

Testing the Voltage Regulator

See Test Procedure 11 – Voltage Regulator on page 12-18.

Voltage Regulator Removal

1. Disconnect battery cables as instructed. **See WARNING “To avoid unintentionally starting...” in General Warning on page 1-2.**
2. Remove the electrical component box cover.
3. Disconnect the voltage regulator red wire (1) at the large post on the solenoid, the yellow wire (4) at the bullet connector, and the black wire (7) from the (NO) terminal of the kill limit switch and at the battery frame ground (**Figure 14-15, Page 14-12**).
4. Remove the voltage regulator mounting screw (8) and remove the voltage regulator (9).

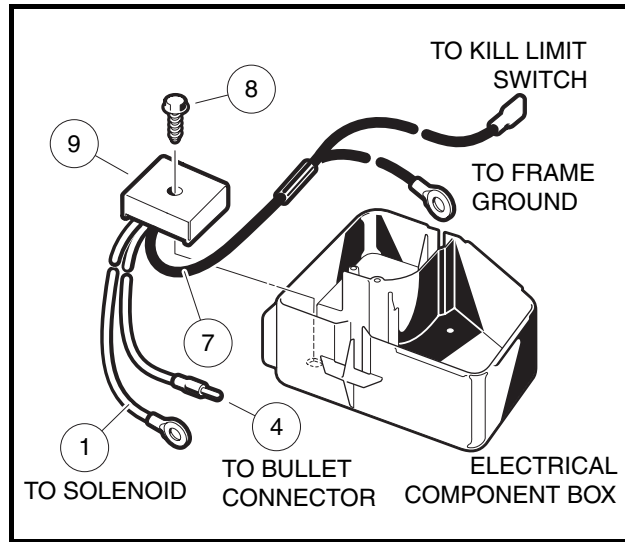

Figure 14-15 Voltage Regulator

Voltage Regulator Installation

1. Position the voltage regulator (9) in the electrical component box and install the mounting screw (8) (Figure 14-15, Page 14-12). Tighten screw to 23 in-lb (2.6 N·m).
2. Connect the voltage regulator red wire (1) at the large post on the solenoid, the yellow wire (4) at the bullet connector, and the black wire (7) at the battery frame ground (Figure 14-15, Page 14-12).
3. Install snap-on electrical component box cover. Be sure to firmly press down all corners. Install screw and tighten to 18 in-lb (2 N·m).
4. Connect battery cables, positive (+) cable first, and tighten hardware to 144 in-lb (16 N·m) (Figure 1-1, Page 1-3). Coat terminals with Battery Terminal Protector Spray (CCI P/N 1014305) to minimize corrosion.
5. Place Forward/Reverse handle in NEUTRAL and place the neutral lockout switch in the MAINTENANCE position. Start the engine and check regulator for proper functioning as described in the voltage regulator test procedure. See Test Procedure 11 – Voltage Regulator on page 12-18.

KEY SWITCH

See General Warning on page 1-1.

Testing the Key Switch

See Test Procedure 4 – Key Switch (Starter Circuit) on page 12-13.

See Test Procedure 17 – Key Switch (Engine Kill Circuit) on page 12-27.

Key Switch Removal

1. Disconnect battery cables as instructed. See WARNING “To avoid unintentionally starting...” in General Warning on page 1-2.
2. Remove the center dash panel.
 - 2.1. Remove the plastic cap (1) covering the mounting screw (2) on each side of the center dash panel (3) (Figure 14-16, Page 14-13).

- 2.2. Loosen, but do not remove, the screw (2) on each side of the center dash panel (3).
- 2.3. Insert screwdriver at the top center of the dash between dash and cowl brace. Gently pry center dash out slightly from under edge of cowl brace.
- 2.4. Pull center dash out from the frame and disconnect the wires from the electrical components mounted on the dash panel. Do not allow wires to touch. **See following NOTE.**

NOTE: Take care to prevent key switch terminals and wires from touching the metal frame around the dash.

- 2.5. Slide center dash panel up the steering column.

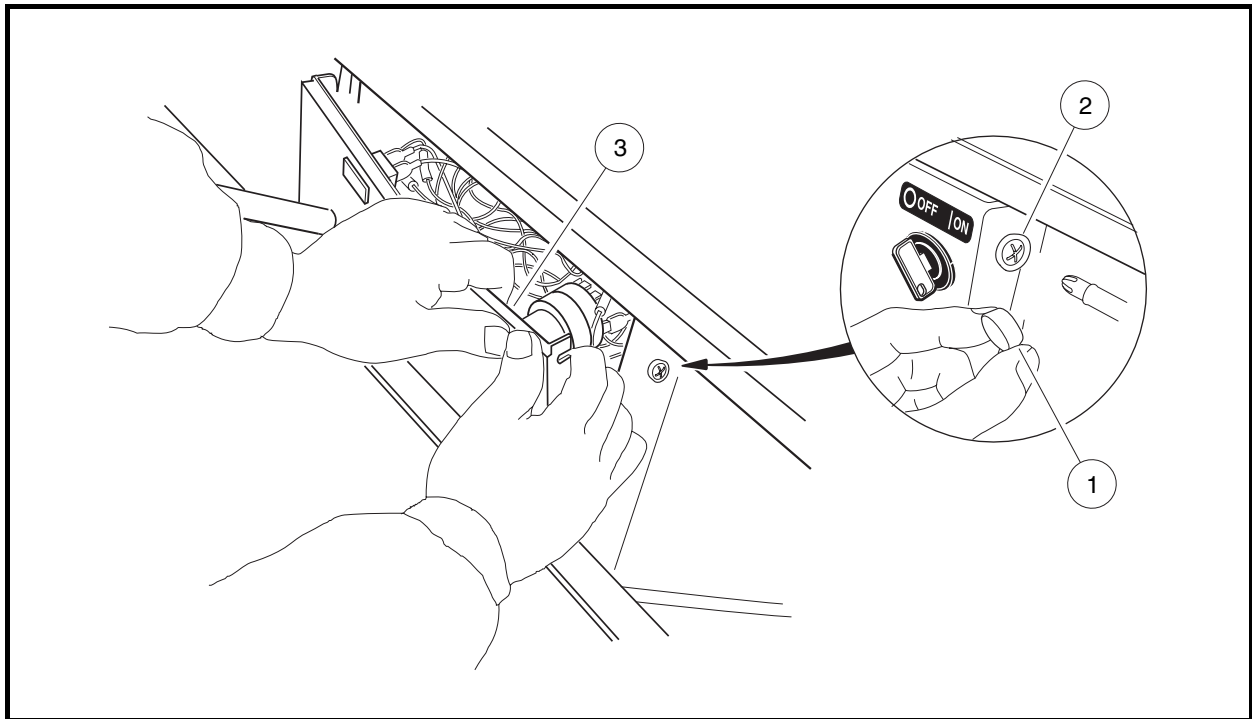

Figure 14-16 Center Dash Panel Removal

3. Disconnect the wires from the key switch.
4. Remove the key switch:
 - 4.1. Remove the key switch cap with a small, flat-blade screwdriver.
 - 4.2. Remove key switch from the dash by holding the key switch and turning the nut on the outside of the dash with a 1-inch socket wrench. Remove the keyed washer with key switch.

Key Switch Installation

1. Reverse removal procedures to install key switch in the dash. Connect wires to key switch. **See Wiring Diagram on page 12-6.** Coat the connectors with Battery Terminal Protector Spray (CCI P/N 1014305) to prevent corrosion. Be sure that key switch terminals cannot touch the frame and that panel is properly seated and snapped in place.
2. Connect battery cables, positive (+) cable first, and tighten hardware to 144 in-lb (16 N·m) (**Figure 1-1, Page 1-3**). Coat terminals with Battery Terminal Protector Spray (CCI P/N 1014305) to minimize corrosion.

SOLENOID

See General Warning on page 1-1.

Testing the Solenoid

See Test Procedure 6 – Solenoid on page 12-15.

Solenoid Removal

1. Disconnect battery cables as instructed. See **WARNING “To avoid unintentionally starting...” in General Warning on page 1-2.**
2. Remove electrical component box cover (**Figure 14-17, Page 14-15**).
3. Disconnect all the wires from the solenoid.
4. Remove the two screws securing the solenoid in place. Remove the solenoid.

Solenoid Installation

1. Install the solenoid in the electrical component box. Use two screws to secure the solenoid to the box and tighten to 14 in-lb (1.6 N·m).
2. Connect all wires as indicated. See **Wiring Diagram on page 12-6.**
 - 2.1. Connect the 6-gauge white wire from the starter/generator, the 18-gauge white wire from the fuel gauge/hour meter, and the 16-gauge red wire from the voltage regulator to the large post on the solenoid.
 - 2.2. Connect the 6-gauge red wire from the battery terminal and the 10-gauge red wire from the fuse block to the other large post on the solenoid.
 - 2.3. Connect the 18-gauge orange wire from accelerator pedal limit switch to small post on the solenoid.
 - 2.4. Connect the 18-gauge blue wire from the key switch to the other small post on the solenoid.
3. Tighten the hex nuts on the large solenoid posts to 60 in-lb (6.8 N·m). Tighten the nuts on the small solenoid posts to 22 in-lb (2.5 N·m).
4. Install the snap-on electrical box cover by pressing down firmly on all corners and install the screw, tightening to 18 in-lb (2 N·m).
5. Connect battery cables, positive (+) cable first, and tighten hardware to 144 in-lb (16 N·m) (**Figure 1-1, Page 1-3**). Coat terminals with Battery Terminal Protector Spray (CCI P/N 1014305) to minimize corrosion.

FUSE

See General Warning on page 1-1.

Testing the Fuse

See Test Procedure 2 – Fuse on page 12-12.

Fuse Removal

1. Disconnect battery cables as instructed. See **WARNING “To avoid unintentionally starting...” in General Warning on page 1-2.**
2. Remove electrical component box cover.
3. Remove the fuse from the fuse block.

Fuse Installation

1. Install the fuse. **See following WARNING.**

⚠ WARNING

- If a fuse is blown, determine the cause of the failure and make necessary repairs before installing a new fuse. Use the appropriately rated fuse; if a fuse with a higher amp rating is used, damage to the vehicle electrical system may occur.
2. Install the snap-on electrical box cover by pressing down firmly on all corners and install the screw, tightening to 18 in-lb (2 N·m).
 3. Connect battery cables, positive (+) cable first, and tighten hardware to 144 in-lb (16 N·m) (**Figure 1-1, Page 1-3**). Coat terminals with Battery Terminal Protector Spray (CCI P/N 1014305) to minimize corrosion.

KILL LIMIT SWITCH

See General Warning on page 1-1.

Testing the Kill Limit Switch

See Test Procedure 16 – Kill Limit Switch on page 12-27..

Kill Limit Switch Removal

1. Disconnect battery cables as instructed. **See WARNING “To avoid unintentionally starting...” in General Warning on page 1-2.**
2. Remove electrical component box cover (1) (**Figure 14-17, Page 14-15**).
3. Remove the two nuts (9) and washers (10) securing the accelerator pedal limit switch (11). Do not disconnect the wires attached to switch (11) (**Figure 14-17, Page 14-15**).
4. Disconnect the two white/black wires and the black wire from the kill limit switch (12).
5. Remove the kill limit switch (12).

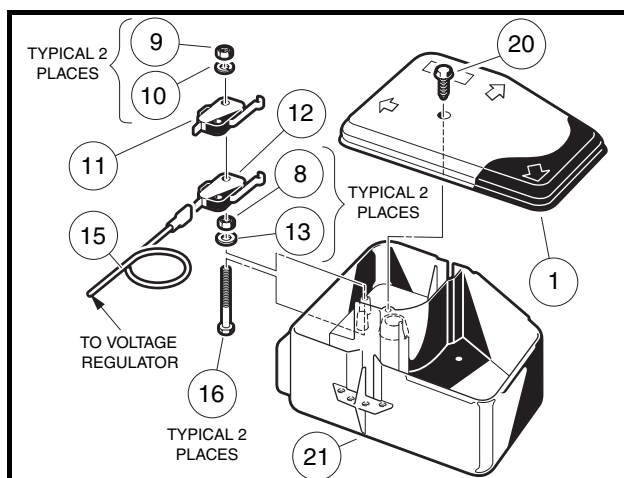

Figure 14-17 Accelerator Starter and Kill Limit Switches

Kill Limit Switch Installation

1. Install the kill limit switch (12) onto the two screws (16) (**Figure 14-17, Page 14-15**).
2. Connect the two white/black wires to the common (COM) terminal and the black wire to the normally open (NO) terminal of the kill limit switch (12) and place the switch on the mounting screws located in the electrical component box. Place the accelerator limit switch (11) on the mounting screws located in the electrical component box.
3. Secure the switches using two washers (10) and two nuts (9). Tighten to 5 in-lb (0.6 N·m). **See following CAUTION.**

⚠ CAUTION

- **Do not overtighten the retaining nuts. If the nuts are overtightened, limit switches could be damaged.**
4. Press and release the accelerator pedal to make sure that both switches are being activated when the pedal is released.
 5. Install snap-on electrical component box cover (1). Be sure to press down firmly all corners. Install screw (20) and tighten to 18 in-lb (2 N·m).
 6. Connect battery cables, positive (+) cable first, and tighten hardware to 144 in-lb (16 N·m) (**Figure 1-1, Page 1-3**). Coat terminals with Battery Terminal Protector Spray (CCI P/N 1014305) to minimize corrosion.

NEUTRAL LOCKOUT LIMIT SWITCH

See General Warning on page 1-1.

Testing the Neutral Lockout Limit Switch

See Test Procedure 7 – Neutral Lockout Limit Switch on page 12-16.

Neutral Lockout Limit Switch Removal

1. Disconnect the battery cables as instructed. **See WARNING “To avoid unintentionally starting...” in General Warning on page 1-2.**
2. Remove the center dash panel (**Figure 14-16, Page 14-13**).
 - 2.1. Remove the plastic cap (1) covering the mounting screw (2) on each side of the center dash panel (3).
 - 2.2. Loosen, but do not remove, the screw (2) on each side of the center dash panel (3).
 - 2.3. Use a screwdriver to gently pry center dash out slightly from under edge of cowl brace.
 - 2.4. Untwist and remove forward/reverse shifter knob and pull center dash out from the frame.
 - 2.5. Rotate center dash panel counter-clockwise around the steering column to gain access to the limit switches (**Figure 14-18, Page 14-17**). **See following NOTE.**

NOTE: Take care to manipulate under-dash wires to prevent damage to wires. It may be necessary to remove key switch from the dash panel to allow dash panel to rotate.

3. Use a wrench and a pair of needle-nosed pliers to remove the two nuts and washers, and remove the limit switch (**Figure 14-19, Page 14-17**).

Neutral Lockout Limit Switch Installation

1. Install the neutral lockout limit switch with two washers and two nuts (**Figure 14-18, Page 14-17**). Tighten to 5 in-lb (0.6 N·m). Place the Forward/Reverse handle in REVERSE to make sure that both switches actuate. **See following CAUTION.**

⚠ CAUTION

- **Do not overtighten the retaining nuts. If the nuts are overtightened, limit switches could be damaged.**
2. Connect wires to neutral lockout limit switch:
 - Connect the black/light blue wire to common (COM) terminal, the tan wire to the normally open (NO) terminal and the gray wire to the normally closed (NC) terminal of the neutral lockout limit switch. **See Wiring Diagram on page 12-6.**
 3. Connect battery cables, positive (+) cable first, and tighten hardware to 144 in-lb (16 N·m) (**Figure 1-1, Page 1-3**). Coat terminals with Battery Terminal Protector Spray (CCI P/N 1014305) to minimize corrosion.
 4. Check limit switch operation.
 - Place the Forward/Reverse handle in the NEUTRAL position. The neutral lockout switch should be in the OPERATE position. Make sure everyone is clear of the vehicle. Turn the key switch to the ON position. The engine should not crank when pressing the accelerator. If the engine does crank, turn the key switch OFF and readjust the shift linkage.
 5. Test drive the vehicle in both forward and reverse to check for proper operation.

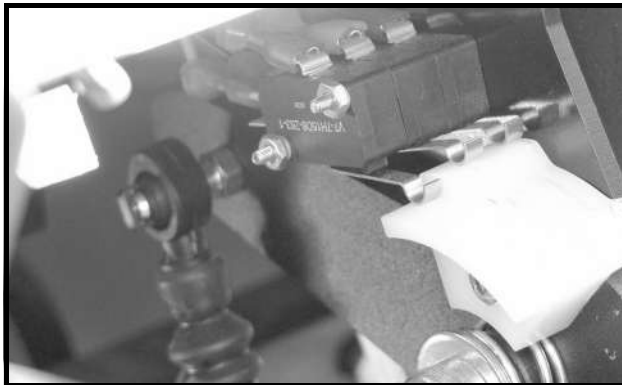

Figure 14-18 Neutral Lockout, Reverse Buzzer and Starter Solenoid Limit Switches



Figure 14-19 Removal of Limit Switches

REVERSE WARNING BUZZER

See General Warning on page 1-1.

Testing the Reverse Warning Buzzer

See Test Procedure 20, Section 11, Page 11-30.

Reverse Warning Buzzer Removal

1. Disconnect battery cables as instructed. See **WARNING “To avoid unintentionally starting...”** in General Warning on page 1-2.
2. Remove the center dash panel. See **Key Switch Removal on page 14-12.**
3. Disconnect the wires from the reverse warning buzzer (2). Do not allow wires to touch (**Figure 14-20, Page 14-18**).
4. Remove the mounting screws (3) securing the buzzer to the center dash.

Reverse Warning Buzzer Installation

1. Install the screws (3) through the buzzer bracket tabs and tighten to 3.5 in-lb (0.40 N·m) (**Figure 14-20, Page 14-18**).
2. Connect the black wire from the key switch to the negative (–) terminal on the buzzer.
3. Connect the red/white wire from the wire harness to the positive (+) terminal on the buzzer.
4. Reverse removal procedures to install the center dash in the vehicle. Be sure that the key switch terminals cannot touch the frame and that the panel is properly seated and snapped in place.
5. Connect battery cables, positive (+) cable first, and tighten hardware to 144 in-lb (16 N·m) (**Figure 1-1, Page 1-3**). Coat terminals with Battery Terminal Protector Spray (CCI P/N 1014305) to minimize corrosion.

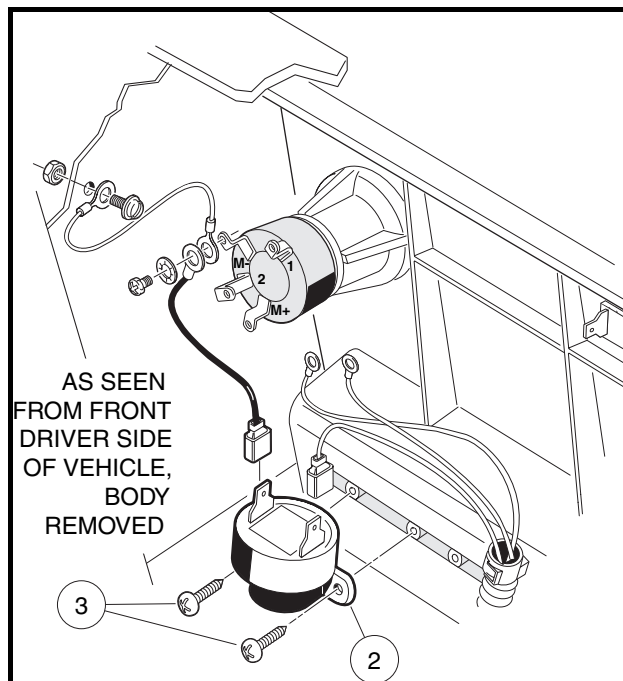

Figure 14-20 Front Reverse Warning Buzzer

REVERSE BUZZER LIMIT SWITCH

See General Warning on page 1-1.

Testing the Reverse Buzzer Limit Switch

See Test Procedure 19 – Reverse Buzzer Limit Switch on page 12-28.

Reverse Buzzer Limit Switch Removal

1. Disconnect battery cables as instructed. See **WARNING** “To avoid unintentionally starting...” in **General Warning** on page 1-2.
2. Disconnect the wires from the reverse buzzer limit switch (4) located on the back of the Forward/Reverse assembly (**Figure 14-18, Page 14-17**).
3. Remove the nuts (2) and washers (6) from the neutral lockout limit switch (5) and slide the neutral lockout limit switch off of the screws. Do not disconnect the wires.
4. Remove the spacers (9) from the reverse buzzer limit switch (4) and slide the reverse buzzer limit switch off the screws.

Reverse Buzzer Limit Switch Installation

1. Install the reverse buzzer limit switch (4), and then install two spacers (9) against the limit switch.
2. Install the neutral lockout limit switch (5) with two washers (6) and two nuts (2). Tighten to 5 in-lb (0.6 N·m). See following **CAUTION**.

▲ CAUTION

- Do not overtighten the retaining nuts. If the nuts are over tightened, limit switches could be damaged.
3. Place the Forward/Reverse handle in REVERSE and make sure that both switches actuate.
 4. Connect the orange wire to the common (COM) terminal and the red/white wire to the normally open (NO) terminal of the reverse buzzer limit switch (4) (**Figure 14-18, Page 14-17**).
 5. Connect battery cables, positive (+) cable first, and tighten hardware to 144 in-lb (16 N·m) (**Figure 1-1, Page 1-3**). Coat terminals with Battery Terminal Protector Spray (CCI P/N 1014305) to minimize corrosion.
 6. Turn the key switch to the ON position. Shift the Forward/Reverse handle to the REVERSE position. The buzzer should sound.

LOW OIL WARNING LIGHT

See General Warning on page 1-1.

Testing the Low Oil Warning Light

See Test Procedure 21 – Low Oil Warning Light on page 12-29.

Low Oil Warning Light Removal

1. Disconnect battery cables as instructed. See **WARNING “To avoid unintentionally starting...”** in General Warning on page 1-2.
2. Remove the center dash panel. See **Key Switch Removal** on page 14-12.
3. Disconnect the wires from the low oil warning light (11) (**Figure 14-21, Page 14-20**). Do not allow wires to touch.
4. Press the retaining tabs and remove the low oil warning light from the center dash.

Low Oil Warning Light Installation

1. Push a new unit into hole in dash until plastic tabs engage dash (**Figure 14-21, Page 14-20**).
2. Connect yellow wire from the key switch and yellow wire from the oil level sensor to the low oil warning light.
3. Install the center dash in reverse order of removal. Be sure that key switch terminals cannot touch the frame and that panel is properly seated and snapped in place.
4. Connect battery cables, positive (+) cable first, and tighten hardware to 144 in-lb (16 N·m) (**Figure 1-1, Page 1-3**). Coat terminals with Battery Terminal Protector Spray (CCI P/N 1014305) to minimize corrosion.

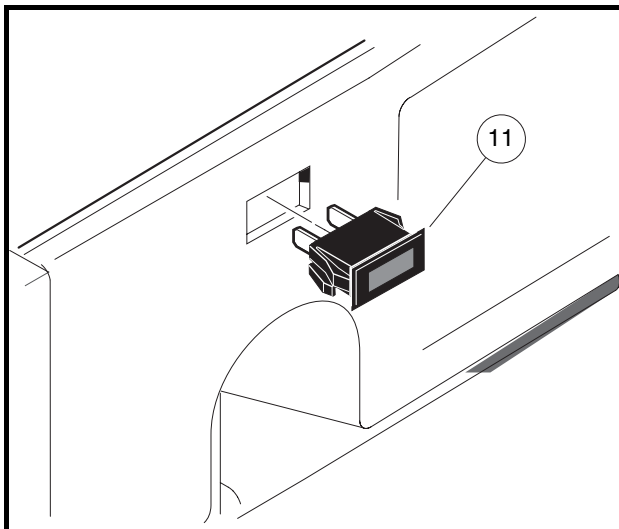

Figure 14-21 Low Oil Warning Light

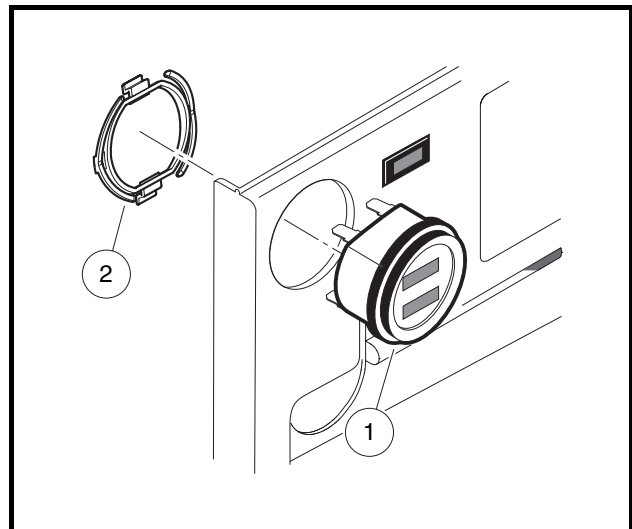

Figure 14-22 Fuel Gauge/Hour Meter Installation

FUEL GAUGE/HOUR METER

See General Warning on page 1-1.

Testing the Fuel Gauge/Hour Meter

See Test Procedure 26 – Fuel Gauge on page 12-32.

See Test Procedure 27 – Hour Meter on page 12-33.

General Information

With the key switch in the OFF position, the fuel gauge field is blank; however, the hour meter field is always ON. When the key switch is turned to ON, the fuel gauge field activates. The fuel gauge initially registers full before indicating the actual fuel level.

The hour meter displays the number of hours of use in increments of 0.1 (one tenth) hour, but does not record additional time unless the key switch is in the ON position and the engine is on. When recording, the hour-glass icon blinks.

Fuel Gauge/Hour Meter Removal

1. Disconnect battery cables as instructed. See **WARNING “To avoid unintentionally starting...” in General Warning on page 1-2.**
2. Remove the center dash panel. See **Key Switch Removal on page 14-12.**
3. Disconnect the wires from the fuel gauge/hour meter (1) (**Figure 14-22, Page 14-20**). Do not allow wires to touch.
4. Remove the mounting clip (2) that secures the gauge/meter. Alternate pulling the lower and upper tabs away from the gauge housing to remove clip.
5. Pull gauge/meter from the instrument panel.

Fuel Gauge/Hour Meter Installation

1. Install a new fuel gauge/hour meter (1) into the hole in the instrument panel until the flange seats against the instrument panel (**Figure 14-22, Page 14-20**).
2. Force the mounting clip (2) onto the back of the fuel gauge/hour meter until fully seated.
3. Connect the wires to the fuel gauge/hour meter. See **Wiring Diagram on page 12-6.**
4. Coat terminals with Battery Terminal Protector Spray (CCI P/N 1014305).
5. Install the center dash in reverse order of removal. Be sure that key switch terminals cannot touch the frame and that panel is properly seated and snapped in place.
6. Connect battery cables, positive (+) cable first, and tighten hardware to 144 in-lb (16 N·m) (**Figure 1-1, Page 1-3**). Coat terminals with Battery Terminal Protector Spray (CCI P/N 1014305) to minimize corrosion.

FUEL LEVEL SENDING UNIT

See General Warning on page 1-1.

The fuel level sending unit is an integral part of the fuel tank and should never be removed. Thoroughly test the fuel level sending unit before replacing the fuel tank.

Testing the Fuel Level Sending Unit

See Test Procedure 25 – Fuel Level Sending Unit on page 12-31.

RPM LIMITER

See General Warning on page 1-1.

Testing the RPM Limiter

See Test Procedure 14 – RPM Limiter on page 12-20.

RPM Limiter Removal

1. Disconnect battery cables as instructed. **See WARNING “To avoid unintentionally starting...” in General Warning on page 1-2.**
2. Remove seat to access engine compartment. **See Section 4 – Body and Trim.**
3. Disconnect the white/black wire from the black wire at the bullet connector located near the RPM limiter (**Figure 14-23, Page 14-22**).
4. Disconnect the other black wire at the other bullet connector near the RPM limiter.
5. Remove the flange-head bolts from the RPM limiter band and remove the RPM limiter and damper (**Figure 14-23, Page 14-22**).

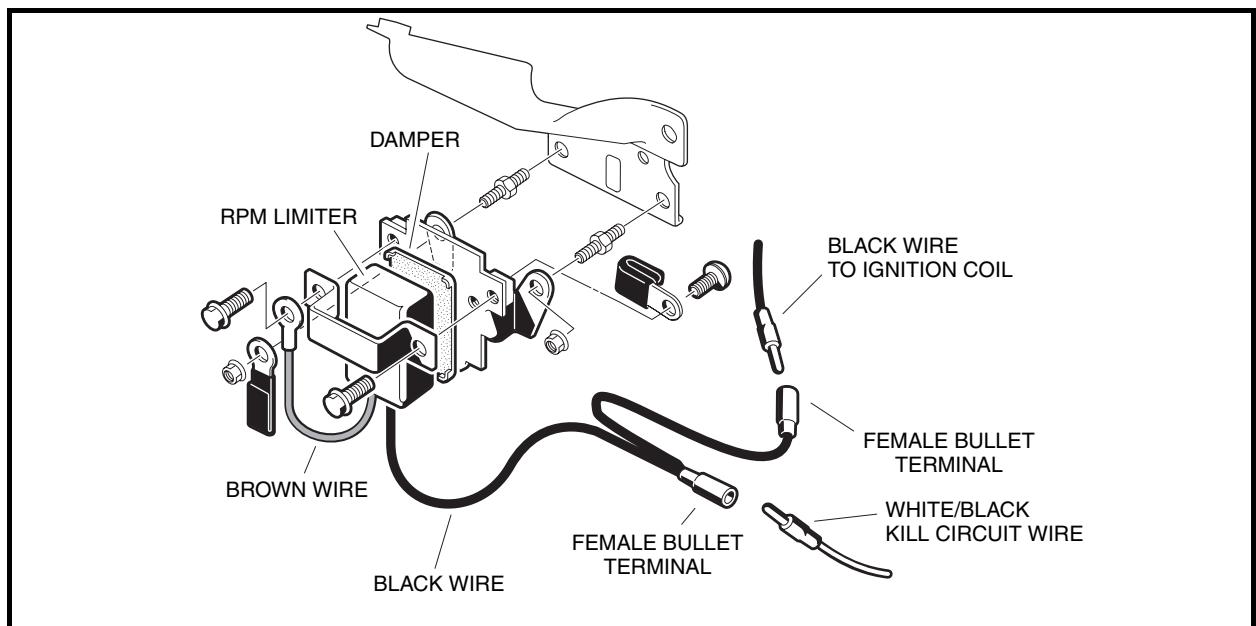

Figure 14-23 RPM Limiter

RPM Limiter Installation

1. Place the RPM limiter damper on the front of the RPM limiter mounting bracket (**Figure 14-23, Page 14-22**).
2. Place the RPM limiter on the damper squarely so that RPM limiter fits tightly against the damper.
3. Place the band over the RPM limiter and align the holes. Place the brown wire ring connector onto the flange-head bolt and secure the left side of the band. Use another flange-head bolt to secure the other side of the band. Make sure the band holds the RPM limiter securely in place. Tighten fasteners to 7 ft-lb (9.5 N·m).
4. Connect black wire at the bullet connector to the white/black wire.
5. Connect battery cables, positive (+) cable first, and tighten hardware to 144 in-lb (16 N·m) (**Figure 1-1, Page 1-3**). Coat terminals with Battery Terminal Protector Spray (CCI P/N 1014305) to minimize corrosion.
6. Install the seat.

IGNITION COIL

See **General Warning on page 1-1**.

Testing the Ignition Coil

See **Test Procedure 13 – Ignition Spark on page 12-20** and **Test Procedure 15 – Ignition Coil on page 12-21**.

Ignition Coil Removal

1. Disconnect battery cables as instructed. See **WARNING “To avoid unintentionally starting...” in General Warning on page 1-2**.
2. Remove seat to access engine compartment. See **Section 4 – Body and Trim**.
3. Disconnect spark plug wire from the spark plug. See **WARNING “To avoid unintentionally starting...” in General Warning on page 1-2**.
4. Remove the muffler. See **Muffler Removal on page 17-1**.
5. Cut the wire tie holding the wire harness to the stiffener (1) and remove the bolts (2) and nuts (3) securing the stiffener to the mounting plate (4) (**Figure 14-24, Page 14-24**).
6. Remove the pan-head bolts (5) securing the fan shroud (8) to the fan housing (9) (**Figure 14-25, Page 14-24**).
7. Loosen, but do not remove, the three bolts (6) attaching the fan housing as shown.
8. Remove the remaining four bolts (10) attaching the fan housing as shown (**Figure 14-25, Page 14-24**), then while opening the housing, detach the spark plug wire grommet (4) from the housing (**Figure 14-27, Page 14-25**).
9. Disconnect the 18-gauge black wire (12) from the spade terminal on the ignition coil (11) and remove the coil by removing two bolts (10) (**Figure 14-26, Page 14-24**).

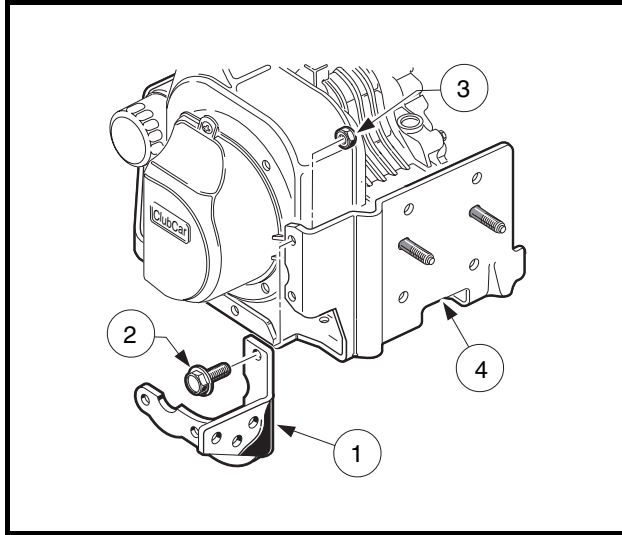

Figure 14-24 Stiffener Removal

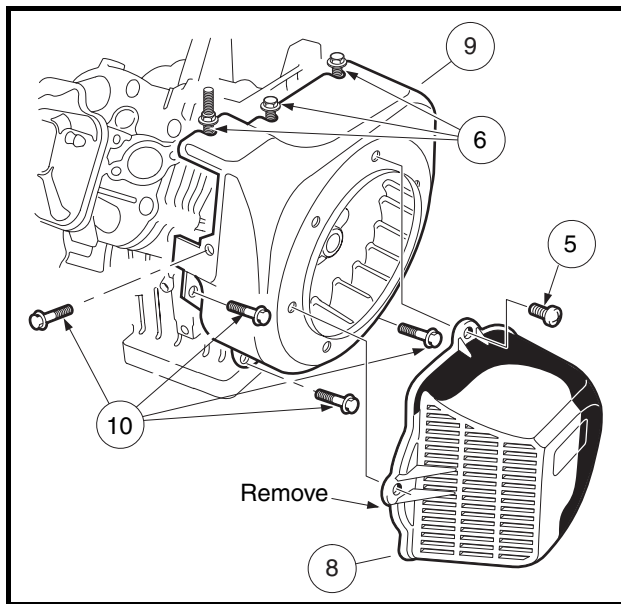

Figure 14-25 Fan Housing Removal

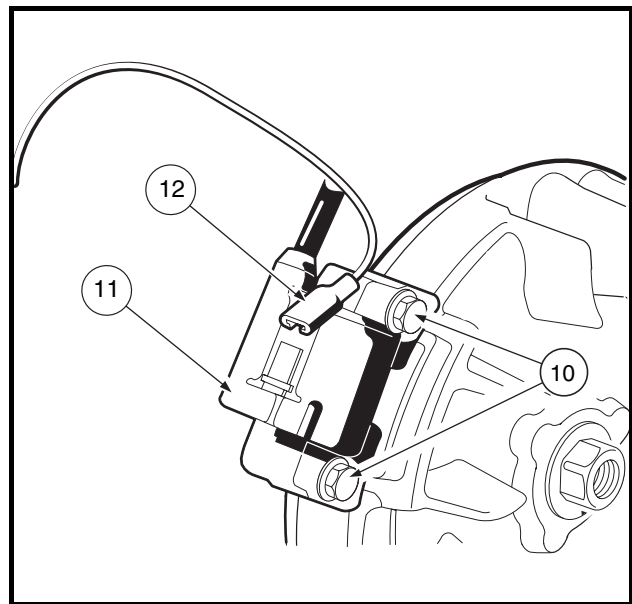

Figure 14-26 Ignition Coil Removal

Ignition Coil Installation

NOTE: If a new ignition coil is being installed, the spark plug cap, gasket, protector tube and grommet must be removed from the old coil and installed on the new coil. See steps 1 through 8 for procedures to remove and install these existing parts.

If the existing ignition coil will be remounted, proceed to step 9.

1. Remove the rubber gasket (1) on the plug cap (2) by rolling back the gasket onto the spark plug wire (**Figure 14-27, Page 14-25**).
2. Remove the cap (2) from the wire by turning the cap counterclockwise three or four revolutions while gently pulling it off the wire.

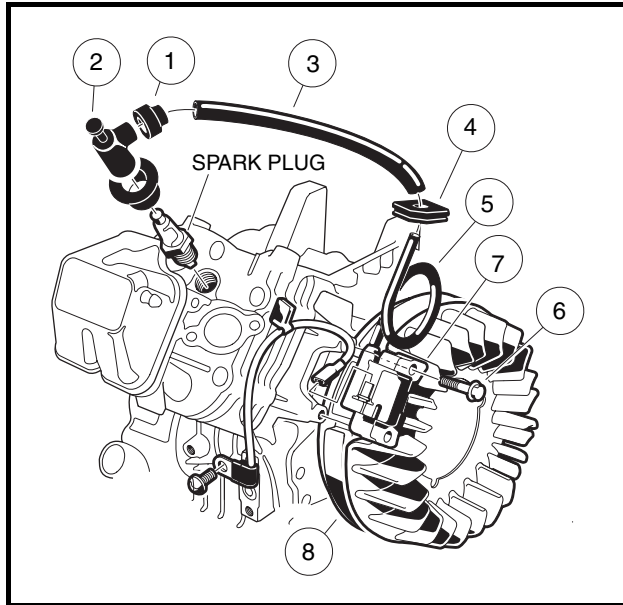

Figure 14-27 Clean Grommet

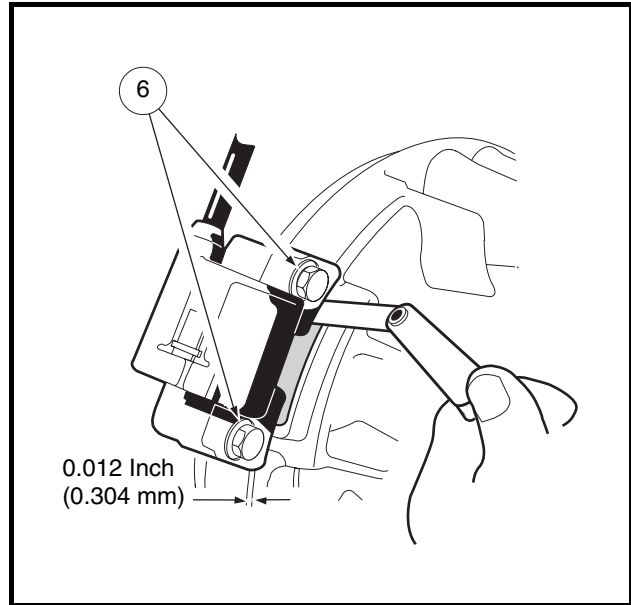

Figure 14-28 Mount Ignition Coil Using Feeler Gauge

3. Remove the gasket (1) and protector tube (3) from the old coil. **See following NOTE.**

NOTE: *Moisten the spark plug wire with water to make gasket removal and installation easier.*

4. Remove the grommet (4) from the old spark plug wire. Clean the grommet and place it on the new spark plug wire (5).
5. Install the protector tube onto the new wire.
6. Slide the gasket onto the end of the new spark plug wire.
7. Install the cap on the new coil spark plug wire by rotating it clockwise three or four revolutions while applying light pressure on the cap.
8. Install the gasket (1) on the cap (2).
9. Position the ignition coil (7) onto the cast mounting bosses on the engine crankcase and tighten the two mounting bolts (6) to finger-tight at this time.
10. Rotate the flywheel (8) until the magnet is positioned directly under the ignition coil. Use a 0.012-inch (0.304 mm) bronze feeler gauge to set the air gap between the ignition coil and the flywheel magnet. Tighten the two mounting bolts (6) to 30 in-lb (3.4 N·m) (**Figure 14-28, Page 14-25**).
11. Connect the 18-gauge black wire to the spade terminal on the coil.
12. Position the fan housing close to the engine crankcase and slide the plug wire grommet into the notch on the housing.
13. When installing fan housing, make sure the top front corner of the housing is above the upper cylinder shroud. The front edge of the fan housing should be behind the lower cylinder shroud. Align the slots in the housing with the flanged bolts loosened earlier.
14. Install the four remaining flange bolts that secure the fan housing to the engine crankcase. Tighten all seven mounting bolts to 90 in-lb (10.2 N·m) (**Figure 14-25, Page 14-24**).
15. Install the stiffener with four hex-head bolts and lock nuts. Tighten the hardware to 23 ft-lb (30.5 N·m).
16. Install the fan shroud with four pan-head bolts (5). Tighten to 50 in-lb (5.7 N·m) (**Figure 14-25, Page 14-24**).

17. Secure the wire harness to the stiffener with a wire tie. Place the wire tie through the lower hole at the back of the stiffener (**Figure 14-24, Page 14-24**).

⚠ CAUTION

- **Make sure wire harness is routed and secured away from the muffler.**
18. Install the muffler. **See Muffler Installation on page 17-1.**
 19. Connect the spark plug wire to the spark plug.
 20. Connect battery cables, positive (+) cable first, and tighten hardware to 144 in-lb (16 N·m) (**Figure 1-1, Page 1-3**). Coat terminals with Battery Terminal Protector Spray (CCI P/N 1014305) to minimize corrosion.

OIL LEVEL SENSOR

See General Warning on page 1-1.

Testing the Oil Level Sensor

See Test Procedure 22 – Oil Level Sensor on page 12-29.

Oil Level Sensor Removal

See Oil Level Sensor Removal on page 15-5.

Oil Level Sensor Installation

See Oil Level Sensor Installation on page 15-5.

HEADLIGHTS

See General Warning on page 1-1.

Testing the Headlight Socket

See Test Procedure 30 – Voltage at Headlight Socket on page 12-35.

Headlight Bulb Removal

1. Disconnect the battery cables as instructed. **See WARNING “To avoid unintentionally starting...” in General Warning on page 1-2.**
2. From the front of vehicle, reach under cowl and turn the wire harness/halogen bulb assembly, (4 and 6), clockwise one-quarter turn (**Figure 14-29, Page 14-27**).
3. Remove the wire harness/halogen bulb assembly (4 and 6) from the headlight lens (7).
4. Lift the retaining tabs on the connector (4) and remove halogen bulb assembly (6).

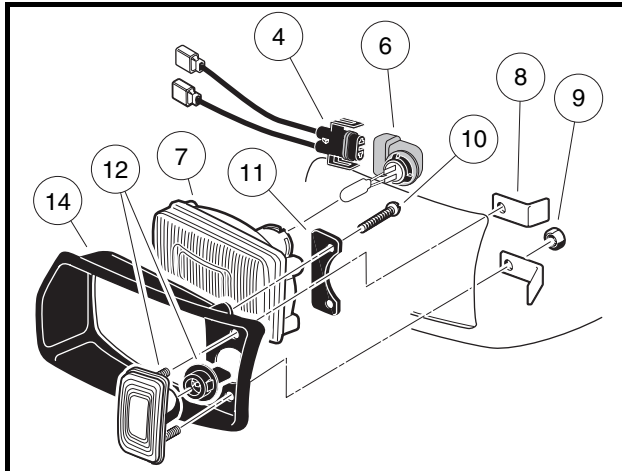

Figure 14-29 Headlight Assembly

Headlight Bulb Installation

NOTE: When handling halogen bulbs, do not touch glass portion of bulb. Oil from finger tips can cause premature failure of bulb.

1. Connect wire harness (4) to the halogen bulb assembly (6). The retaining tab should lock onto the halogen bulb assembly (**Figure 14-29, Page 14-27**).
2. From the front of vehicle, reach under cowl and insert wire harness/halogen bulb assembly (4 and 6), into the headlight lens (7).
3. Turn the wire harness/halogen bulb assembly (4 and 6) counterclockwise one-quarter turn.
4. Connect battery cables, positive (+) cable first, and tighten hardware to 144 in-lb (16 N·m) (**Figure 1-1, Page 1-3**). Coat terminals with Battery Terminal Protector Spray (CCI P/N 1014305) to minimize corrosion.

VOLTAGE LIMITER

See General Warning on page 1-1.

Testing the Voltage Limiter

See Test Procedure 29, Section 12, Page 12-35.

Voltage Limiter Removal

1. Turn the key switch OFF and remove the key. Place the Forward/Reverse handle in the NEUTRAL position. Chock the wheels.
2. Disconnect the battery cables as instructed. See **WARNING “To avoid unintentionally starting...”** in **General Warning on page 1-2.**
3. Remove the instrument panel. See **Key Switch Removal on page 14-12.**
4. Disconnect wires from the voltage limiter (1). Do not allow wires to touch (**Figure 14-30, Page 14-28**).

NOTE: Identify terminal for solid black wire and terminal for black/white wire.

5. Remove the mounting hardware (2) from the voltage limiter and remove it from the vehicle.

Voltage Limiter Installation

1. Mount the voltage limiter to the frame using the mounting hardware and tighten to 25 in-lb (2.8 N·m) (**Figure 14-30, Page 14-28**).
2. Connect the black/white wire from harness to the negative (–) terminal on the diode.
3. Connect the solid black wire from the ground terminal block to the positive (+) terminal on the diode.
4. Install the dash panel in reverse order of removal. See **Key Switch Removal on page 14-12.**
5. Connect the battery cables, positive (+) cable first, and tighten the terminals to 144 in-lb (16.3 N·m). Coat terminals with Battery Terminal Protector Spray (CCI P/N 1014305).

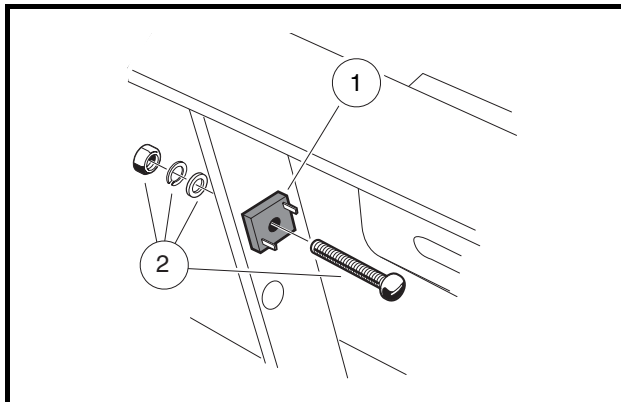

Figure 14-30 Voltage Limiter

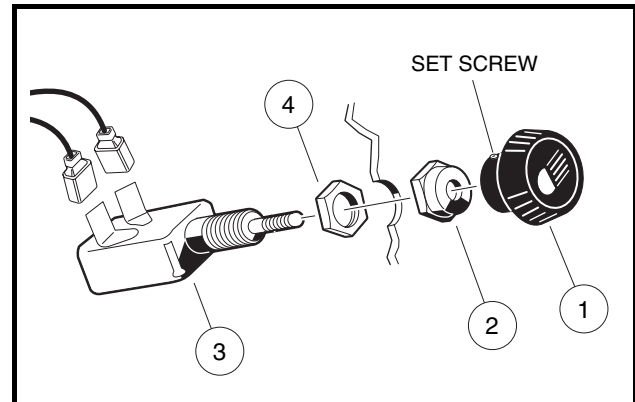

Figure 14-31 Light Switch

HEADLIGHT SWITCH

See General Warning on page 1-1.

Testing the Light Switch

See Test Procedure 28 – Light Switch on page 12-34.

Headlight Switch Removal

1. Disconnect the battery cables as instructed. See **WARNING “To avoid unintentionally starting...”** in **General Warning on page 1-2**.
2. Loosen the set screw locking the light switch knob (1) to the shaft (**Figure 14-31, Page 14-28**).
3. Remove the center dash panel. See **Key Switch Removal on page 14-12**.
4. Disconnect the wires from the light switch.
5. Remove the outer nut (2) from the switch (**Figure 14-31, Page 14-28**).
6. Remove the light switch (3) from the center dash.

Headlight Switch installation

1. Connect the wires to the light switch. See **Wiring Diagram on page 12-6**.
2. Thread the check nut (4) onto the switch until an equal number of threads show on both sides. Insert the switch through the center dash and install the nut on the outside of the dash. Tighten the nut to 14 in-lb (1.6 N·m) (**Figure 14-31, Page 14-28**).
3. Push the light switch shaft in. Screw the knob onto the end of the shaft until the knob touches the outer nut. Then turn the knob in the opposite direction until the headlight beams on the knob are horizontal to the ground. Tighten the set screw to lock the knob to the shaft.
4. Install the center dash in reverse order of removal. Be sure that key switch terminals cannot touch the frame and that panel is properly seated and snapped in place.
5. Connect battery cables, positive (+) cable first, and tighten hardware to 144 in-lb (16 N·m) (**Figure 1-1, Page 1-3**). Coat terminals with Battery Terminal Protector Spray (CCI P/N 1014305) to minimize corrosion.

BATTERY

See General Warning on page 1-1.

⚠ DANGER

- Due to the danger of an exploding battery, wear a full face shield and rubber gloves when working on or near batteries.
- **Battery – Explosive gases! Do not smoke. Keep sparks and flames away from the vehicle and service area. Ventilate when charging or operating vehicle in an enclosed area. Wear a full face shield and rubber gloves when working on or near batteries.**
- Tools, wires, and metal objects can cause sparks when shorted across a battery.
- Follow all instructions carefully when working with batteries.
- Charge battery in a well-ventilated area only.
- **Battery – Poison! Contains acid! Causes severe burns. Avoid contact with skin, eyes, or clothing. Antidotes:**
 - External: Flush with water. Call a physician immediately.
 - Internal: Drink large quantities of milk or water followed with milk of magnesia or vegetable oil. Call a physician immediately.
 - Eyes: Flush with water for 15 minutes. Call a physician immediately.

⚠ WARNING

- Do not jump start a dead battery using another battery and jumper cables.

General Information

See preceding **DANGER** and **WARNING** statements.

Gasoline vehicles are equipped with 12-volt, low-maintenance batteries that requires infrequent watering. When changing a 12-volt battery in any gasoline-powered vehicle, the same size battery with adequate amperage ratings should be used as a replacement.

A group 70, side-post battery (CCI P/N 1012328), with a 650 cranking amp rating at 32 °F (0 °C) (500 CCA at 0 °F (-17.8 °C)) and a reserve capacity of at least 105 minutes is recommended. The group 70 classification indicates battery size: 8-1/4 inches W x 6-1/2 inches D x 7-1/4 inches H (21.0 cm W x 16.5 cm D x 18.4 cm H). It is important to use the proper size to ensure that the battery clamp will fit correctly.

Testing the Battery

See Test Procedure 1 – Battery on page 11-9.

See Test Procedure 24 – Battery Test (Under Load) on page 11-31..

Preventive Maintenance

1. To keep the battery in good operating condition, remove any corrosion immediately. Post connections should be clean and tight. Any frayed or worn wires should be replaced. After all cables have been connected and properly tightened to 144 in-lb (16 N·m), coat terminals with Battery Terminal Protector Spray (CCI P/N 1014305) to prevent future corrosion. **See preceding WARNINGS and following CAUTION.**

⚠ CAUTION

- **If battery wire terminals are damaged or corroded, replace or clean them as necessary. Failure to do so may cause them to overheat during operation and could result in a fire, property damage, or personal injury.**
2. The battery should be kept clean and dry to prevent self-discharge. Any dirt, grime or acid spillage should be removed. Wash the battery with a bristle brush using water and bicarbonate of soda (1 cup (237 mL) baking soda per 1 gallon (3.8 L) of water). Rinse with water. Do not allow solution to enter battery through the vent cap holes. **See Self-Discharge on page 14-31.**
 3. Maintain proper water level. **See Water Level on page 14-31.**
 4. Check battery periodically to see that it is in a full state of charge. **See Charging the Battery on page 14-33.**
 5. Keep battery hold-down clamp tight. **See Vibration Damage on page 14-32.**

Self-Discharge

Dirt and battery acid can provide a path for a small current draw that slowly discharges the battery. To prevent self-discharge, the battery should always be kept clean.

Hot weather also has an effect on a battery's self-discharge rate. The higher the temperature, the quicker a battery will discharge. In hotter climates, therefore, the battery should be checked more often. When storing the battery, keep in a cool place. **See Battery Storage on page 14-33.**

Water Level

The water level should be checked semi-annually to be sure water is at its proper level (**Figure 14-32, Page 14-31**). Never allow the water level to fall below the tops of the plates because this will cause the exposed part of the plate to become permanently inactive. Check the water level more frequently in hot weather or when the battery becomes old.

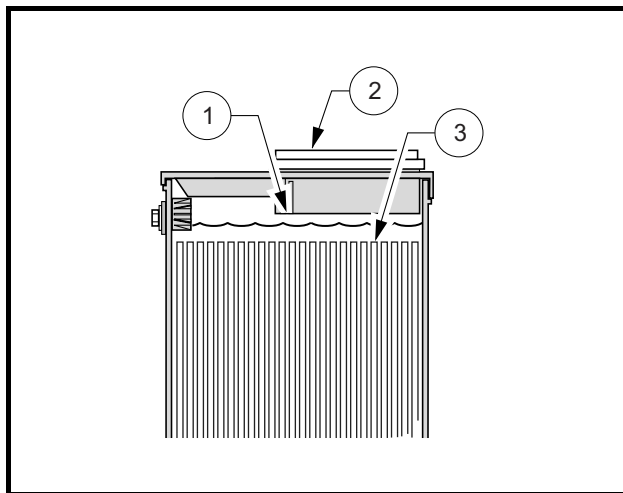

Figure 14-32 Battery Electrolyte Level

1. Level Indicator 2. Cap 3. Plates
Electrolyte level at least 1/2 inch (13 MM) above plates or to level indicator.

Vibration Damage

The battery hold-down clamp should always be tight enough to keep the battery from bouncing. Battery life may be severely shortened if the clamp is too loose. Excessive vibration shortens the life of the battery. It may also cause acid to leak out of the vent caps and corrosion to build up on surrounding metal parts. The acid that is lost reduces the capacity of the battery and cannot be replaced.

Mineral Content

For the longest battery life, distilled water should be used in the battery. However, if tap water is going to be used, contact your local water department to be sure mineral contents are below the levels listed in the following table. **See following NOTE.**

NOTE: Contact your local water department for mineral content analysis.

IMPURITY	ALLOWABLE CONTENT (PARTS PER MILLION)
Suspended matter	Trace
Total solids	100.0
Calcium and Magnesium Oxides	40.0
Iron	5.0
Ammonia	8.0
Organic matter	50.0
Nitrates	10.0
Nitrites	5.0
Chloride	5.0

Battery Removal

See General Warning on page 1-1 and DANGER on page 14-30.

1. Turn the key switch OFF and remove the key. Place the Forward/Reverse handle in the NEUTRAL position. Chock the wheels.
2. Disconnect the battery cables as instructed. **See WARNING “To avoid unintentionally starting...” in General Warning on page 1-2.**
3. Remove the battery hold-down clamp from the battery.
4. Lift the battery from the vehicle. **See following WARNING.**

WARNING

- **Keep the battery in an upright position to prevent electrolyte leakage. Tipping the battery beyond a 45° angle in any direction can allow a small amount of electrolyte to leak out of the vent hole. Do not exceed this 45° angle when lifting, carrying or installing battery. The battery acid could cause severe personal injury when accidentally coming in contact with the skin or eyes, and could damage clothing.**

Charging the Battery

See **General Warning** on page 1-1 and **DANGER** on page 14-30.

1. Charge the battery using an automotive type 12-volt battery charger. Follow all warnings and procedures supplied by the battery charger manufacturer.
2. Attach the positive (+) charger cable to the positive (+) battery post.
3. Attach the negative (–) charger cable to the negative (–) battery post.
4. The battery may be charged with a slow charge (3-10 amps) or a fast charge (20-30 amps). Charge until the specific gravity reaches 1.250. **See following WARNING.**

⚠ WARNING

- If the battery case feels hot (approximately 125 °F (52 °C) or more), emits gases, or fluid boils from vents, stop charging immediately. Failure to stop charging battery when any of these conditions are present could result in an explosion, personal injury and/or damage to the battery.
- Do not disconnect the charger DC leads from the battery when the charger is on. The resulting arcing between the DC leads and battery post could cause an explosion.
- If the charger must be stopped, disconnect the AC supply cord from the wall outlet before disconnecting the DC leads from the battery. Allow the battery to cool to room temperature and resume charging battery at a lower amp rate.

Battery Installation

See **General Warning** on page 1-1 and **DANGER** on page 14-30.

1. Place the battery into the vehicle with the battery posts facing the engine.
2. Secure the battery to the vehicle with the clamp and install bolt, washer and locknut and tighten to 144 in-lb (16.3 N·m). A loose battery clamp may allow the battery to become damaged from vibration or jarring.
3. Connect the battery cables, positive (+) cable first, and tighten the terminals to 144 in-lb (16.3 N·m) (**Figure 1-1, Page 1-3**). Coat terminals with Battery Terminal Protector Spray (CCI P/N 1014305).

Battery Storage

See **General Warning** on page 1-1 and **DANGER** on page 14-30.

1. Keep the battery clean and free of corrosion. **See Preventive Maintenance** on page 14-30.
2. The battery cables should be disconnected from the battery so the battery can be connected to the charger. The battery can be left in the vehicle. Disconnect the negative (–) cable first. **See WARNING “To avoid unintentionally starting...” in General Warning** on page 1-2.
3. Fully charge the battery prior to storage.
4. Store in a cool, dry area. The colder the area in which the battery is stored, the less the battery will self-discharge. A battery stored at 0 °F (-17.8 °C) will discharge very little over a four-month period. A battery stored at 80 °F (27 °C) will have to be recharged every few weeks.
5. Check the state of charge periodically. A battery that is discharged and left in a cold environment can freeze and crack. If the specific gravity drops below 1.220, the battery should be recharged. **See following WARNING.**

 WARNING

- If the battery is frozen or the container is bulged, discard battery. A frozen battery can explode.
6. The frequency of recharging required depends on the temperature of the storage area, but it is recommended that the battery be monitored for state of charge every month. Also, if the storage area is unheated in a cold climate and recharging is required, it is recommended that the area be heated to at least 60 °F (16 °C) prior to charging. The battery will not charge effectively in cold temperatures for the same reasons that it does not discharge as rapidly in cold temperatures.

Charging a Dead Battery

See General Warning on page 1-1 and DANGER on page 14-30.

The vehicle is equipped with a starter/generator. The generator is not designed to charge a dead battery. If the vehicle battery has become discharged, it must be charged using a properly rated automotive type charger. See following **WARNING**.

 WARNING

- Do not jump-start a dead battery using another battery and jumper cables.

GROUND CABLES

Testing the Ground Cables

See Test Procedure 3 – Ground Cables on page 12-12.

SECTION 15 – ENGINE

⚠ DANGER

- See General Warning on page 1-1.

⚠ WARNING

- See General Warning on page 1-1.

GENERAL INFORMATION

See General Warning on page 1-1.

This gasoline vehicle is powered by a 4-cycle, overhead valve, single cylinder, air-cooled engine. The 4-cycle engine has an oil reservoir (crankcase) similar to automobiles, trucks, aircraft, heavy equipment, machinery and other applications designed for reliable heavy-duty service. The engine has two major component assemblies: the cylinder assembly and the crankcase assembly. **See following NOTE.**

***NOTE:** Engine rotation is clockwise as viewed from the clutch side of the engine.*

This section contains information for removing and replacing the engine. For complete instruction on engine disassembly, repair, rebuilding, and reassembly, see your authorized dealer.

BEFORE SERVICING

Carefully read the applicable information and instructions before beginning engine service. Diagrams, DANGER, WARNING, CAUTION and NOTE statements and detailed descriptions have been included wherever necessary. Anyone attempting engine service should have knowledge and experience in small engine service and repair.

ENGINE ROTATION

When turning the crankshaft by hand, always turn it clockwise as viewed from the clutch side of the engine. This will ensure proper adjustments.

SPARK PLUG

Spark plugs are selected to suit specific engine design and vehicle operating conditions. The spark plug (CCI P/N 101881101) is designed to give maximum life and efficient combustion of fuel. The spark gap should be set to 0.027-0.031 inches (0.69-0.79 mm).

Spark Plug Removal

See General Warning on page 1-1.

⚠ CAUTION

- Before removal and disassembly, clean the engine.

Remove all dirt from plug base in the cylinder head before removing plug. Use a 13/16-inch deep well socket wrench or 13/16-inch spark plug wrench to loosen the plug.

Spark Plug Cleaning, Inspection and Repair

Examine the plug (**Figure 15-1, Page 15-2**). The deposits on the plug base and electrode are an indication of the correct heat range and efficiency as well as a guide to the general condition of the engine, fuel and air mixture and ignition system. If all of the above conditions are proper, the spark plug should be a light brown color. There should be no bridging between the electrode and base. The electrode should not be eroded. Black color, excessive carbon, and/or a wet plug indicates that the fuel is too rich. White, burned or melted electrodes indicate the fuel is too lean or pre-igniting. Oily deposits on the plug electrode are an indication of worn rings, valve guides, cylinder wall, etc. Also examine the spark plug wire. Remove rubber boot and inspect internal spring for damage. Inspect spark plug wire for damage and be sure spring coil is securely attached to spark plug. **See following WARNING.**

⚠ WARNING

- **Remove spark plug wire to avoid accidental start up of the engine when servicing vehicle. To avoid ignition of fuel and serious personal injury or death, never try to start the engine with plug removed from engine.**

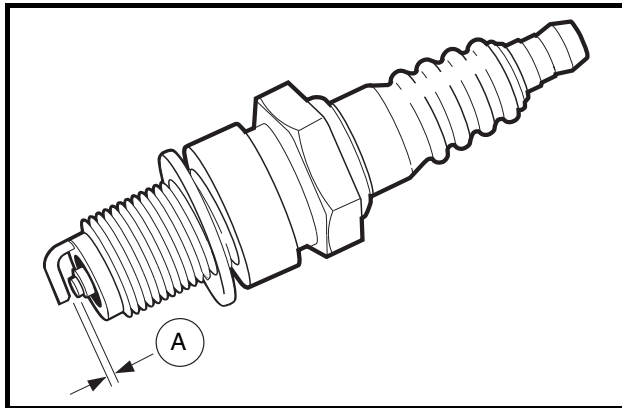

Figure 15-1 Spark Plug

Testing the Spark Plug

Check the sparking ability of a cleaned and properly gapped plug on a sparking comparator if possible. Spark should be blue and strong and able to jump a 5/16-inch (8 mm) gap.

Setting the Spark Gap

1. Pass a contact point file between the electrodes to produce flat, parallel surfaces to facilitate accurate gauging.
2. Use a wire type gauge. Bend the outside or ground electrode so only a slight drag on the gauge is felt when passing it between the electrode. Never make an adjustment by bending the center electrode. Set gap (A) to 0.027-0.031 inches (0.69-0.79 mm) (**Figure 15-1, Page 15-2**).

Spark Plug Installation

NOTE: Before installing the plug, check the condition of the threads in the cylinder head. Soften deposits in cylinder head threads with penetrating oil and clean the threads with a tap if necessary.

Use a high temperature, anti-seize lubricant on the threads of the spark plug to reduce friction when installing a new plug, and reduce "gauling" and thread seizing for future replacements.

1. Install the spark plug by threading it in until finger tight, then tighten the spark plug to 20 ft-lb (27 N·m).

CYLINDER HEAD

See General Warning on page 1-1.

GENERAL INFORMATION

Test cylinder compression using a standard compression tester. Low compression would normally indicate a problem in the cylinder assembly such as defective rings, gaskets, etc. At a cranking speed of 550-600 RPM, the compression should be 156-185 psi. **See Engines and Transaxles Manual for inspection and repair.**

BREATHER VALVE (REED VALVE)

General Information

The function of the breather is to create a vacuum in the crankcase which prevents oil from being forced out of the engine through the piston rings, oil seals or gaskets. The breather has a reed valve which limits the direction of air flow caused by the piston moving up and down. Air can flow out of the crankcase, but the one-way reed valve blocks return flow and therefore maintains a vacuum in the crankcase.

Oil laden air in the crankcase passes through the reed valve and expands into the rocker chamber. In the rocker chamber most oil separates from the air and drains back to the crankcase. The air passes through a tube and vents to the intake manifold. **See Engines and Transaxles Manual for inspection and repair.**

CRANKCASE

See General Warning on page 1-1.

ENGINE REMOVAL

To perform repairs on crankcase components, remove engine from the vehicle. **See following CAUTION.**

⚠ CAUTION

- Before removal and disassembly, clean the engine.

1. Remove the powertrain. **See Unitized Transaxle Removal, Section 18, Page 18-6. See following NOTE.**

NOTE: The crankshaft has left-hand threads at the clutch mounting hole.

2. Remove starter/generator. **See Starter/Generator Removal, Section 13, Page 13-1.**
3. Remove drive clutch. **See Drive Clutch Removal, Section 20, Page 20-4 and following NOTE.**
4. Remove muffler. **See Muffler Removal, Section 17, Page 17-1.**
5. Remove engine mounting hardware (items 1, 2, 5 and 6) **(Figure 15-4, Page 15-4).**
6. Lift engine from the mounting plate.
7. Remove crankcase oil drain plug and filler tube. Tip the engine slightly to allow all of the oil to drain from the crankcase. Dispose of engine oil properly.

CRANKCASE COVER REMOVAL

1. Remove yellow jumper wire (11) from cord connector (12) **(Figure 15-2, Page 15-4).**
2. Remove nuts and clamps at two-ended bolts (1 and 2) **(Figure 15-3, Page 15-4).**

- Remove eight bolts (3) and remove the crankcase cover (4). **See following NOTE.**

NOTE: If the crankcase cover sticks, tap lightly with a plastic mallet on alternate sides near the dowel pins (5) (Figure 15-3, Page 15-4).

- Remove the crankcase cover gasket completely. It may stick to the flanged surface of the crankcase.

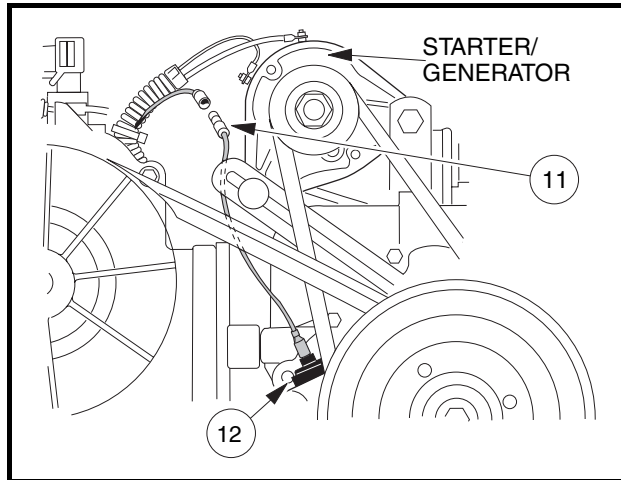

Figure 15-2 Oil Level Sensor Wire

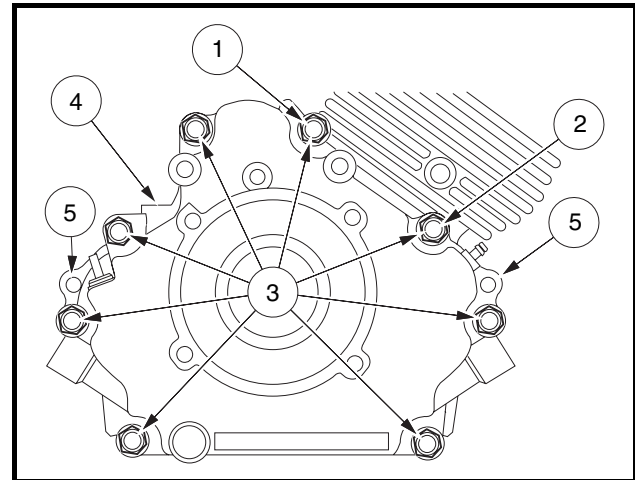

Figure 15-3 Crankcase Cover

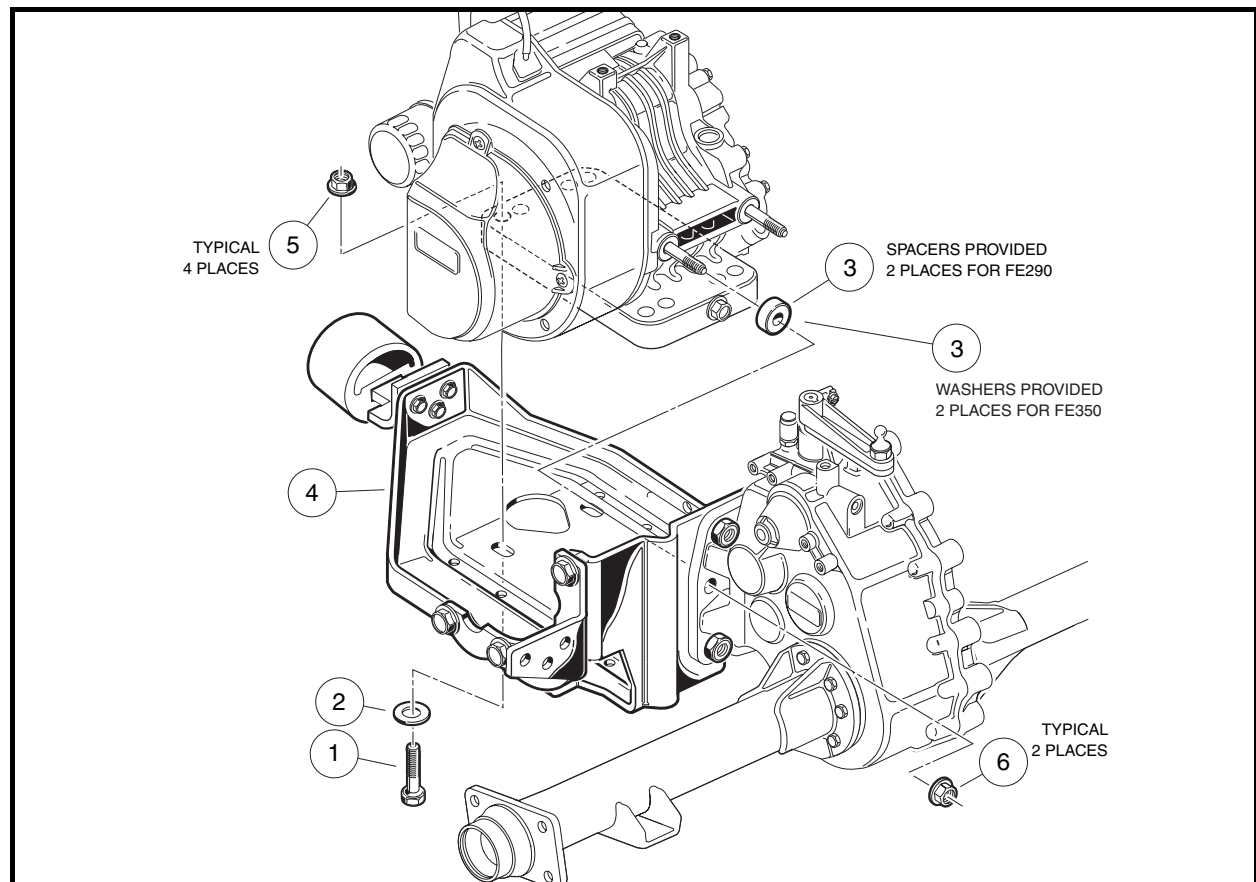

Figure 15-4 Engine Mounting Plate

OIL LEVEL SENSOR

Testing the Oil Level Sensor

See Test Procedure 21, Section 11, Page 11-30.

Oil Level Sensor Removal

1. If not already removed, remove crankcase cover. **See Crankcase Cover Removal on page 15-3.**
2. Disconnect the oil level sensor wire (2) from the cord connection (1) (**Figure 15-2, Page 15-4**).
3. Remove the screw (3) from the wire clamp (4).
4. Remove the two mounting screws from the inside of the crankcase cover and remove the oil level sensor and bracket.
5. If necessary, remove the three screws (7) that hold the sensor to the bracket (5).

Oil Level Sensor Installation

1. If the oil level sensor was removed from the bracket, install sensor (6) into bracket (5) and secure with three screws (7) (**Figure 15-5, Page 15-5**). Tighten to 17 in-lb (1.9 N·m).
2. Position the sensor and bracket on inside of crankcase and install two mounting screws.
3. Connect sensor wire (2) to cord connector (1) (**Figure 15-5, Page 15-5**).
4. Install screw (3) through wire clamp and into crankcase cover. Tighten to 30 in-lb (3.4 N·m).

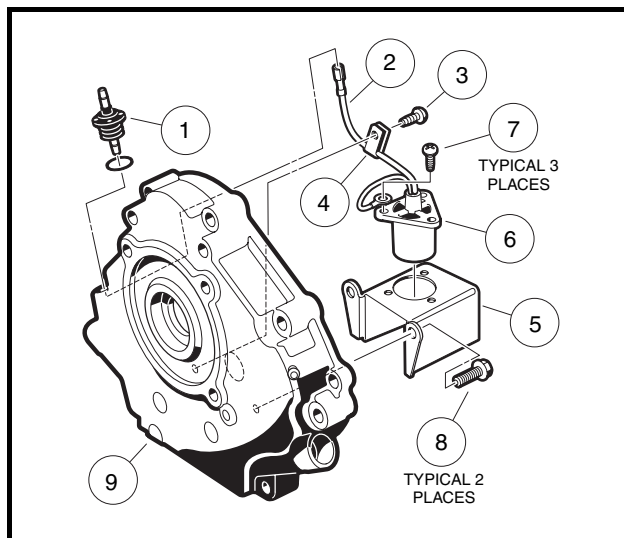

Figure 15-5 Oil Level Sensor

CRANKCASE COVER INSTALLATION

⚠ CAUTION

- Before assembly, make sure parts are clean.
- Do not reuse the gasket. Install a new one.
- Install and tighten crankcase cover bolts as instructed. Failure to do so could cause the cover to become warped.

1. Clean the gasket surfaces on the crankcase cover to fit a new gasket during installation and inspect the oil seal for wear and damage.
2. Install crankcase cover. Using HANDS ONLY, seat cover completely against the crankcase. If the cover will not seat, the camshaft is not installed correctly.
3. Install and finger tighten evenly the eight cover mounting bolts (**Figure 15-6, Page 15-6**).
4. Tighten the cover mounting bolts in two steps. First, in the sequence shown, tighten all eight bolts to approximately 130 in-lb (14 N·m). Then, repeating the sequence, tighten them to 250 in-lb (28.2 N·m) (**Figure 15-6, Page 15-6**).
5. Connect the yellow jumper wire (11) to the cord connector (12) (**Figure 15-2, Page 15-4**).

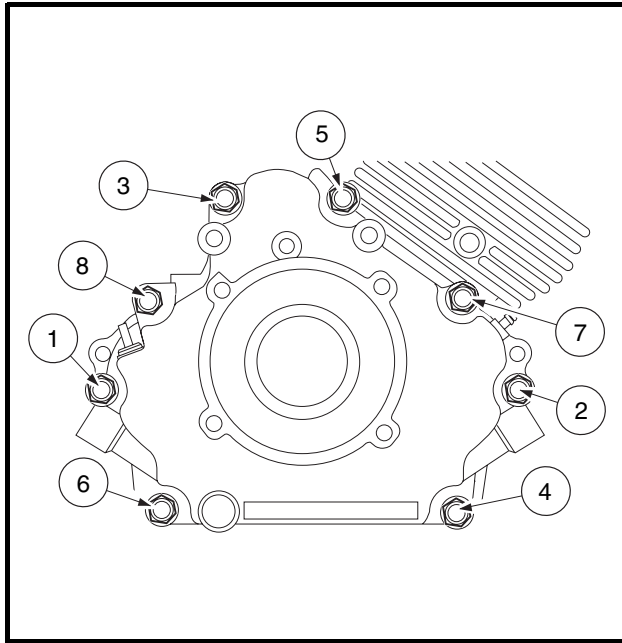

Figure 15-6 Crankcase Cover Installation

IGNITION COIL AND FLYWHEEL

See General Warning on page 1-1.

Ignition Coil and Flywheel Removal

1. Loosen three screws and remove the remaining four screws attaching the flywheel housing as shown, then remove the housing (**Figure 15-7, Page 15-7**).
2. Disconnect the ignition coil (1) from its primary lead wire at the connector (2). Remove the two bolts (3) and take out the ignition coil (**Figure 15-8, Page 15-7**).

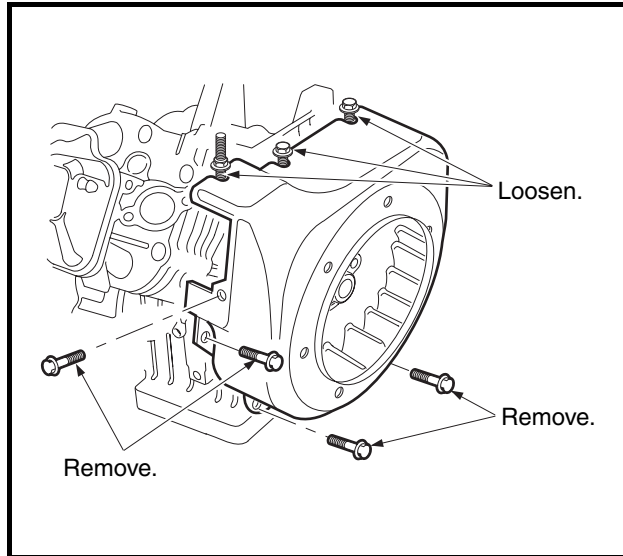

Figure 15-7 Flywheel Housing

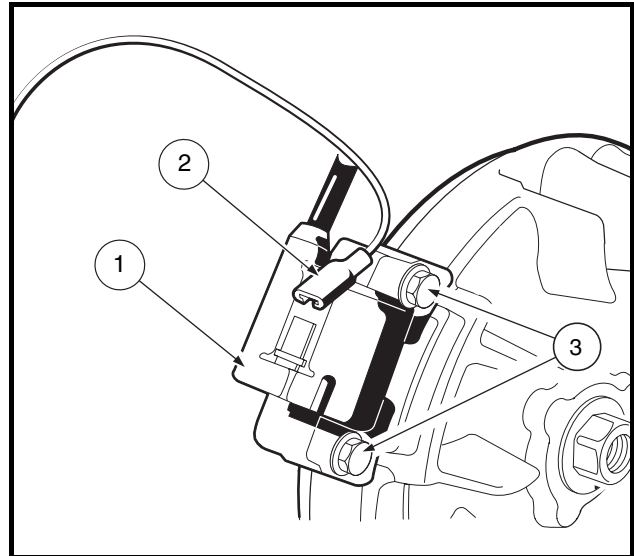

Figure 15-8 Ignition Coil

3. Hold the flywheel (4), not the fan (7), with a strap wrench (5) and, using a 25 mm socket, remove the flywheel nut (and flat washer) by turning it counterclockwise (**Figure 15-9, Page 15-7**). See following **CAUTION**.

⚠ CAUTION

- The flywheel nut has right-hand threads. Turn it clockwise to tighten, or counterclockwise to loosen.
- Do not damage the fan blades with the strap wrench. Do not place screwdriver or pry bar in the fan blades.

4. Remove the flywheel with a puller (CCI P/N 1016627).
5. Remove the flywheel key from its groove.

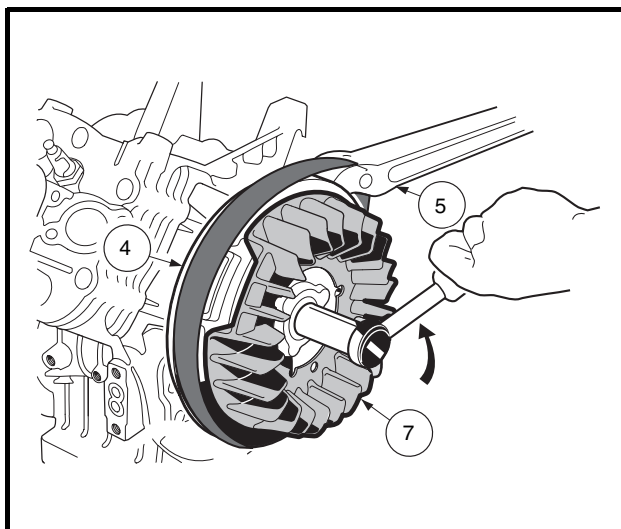

Figure 15-9 Flywheel Nut

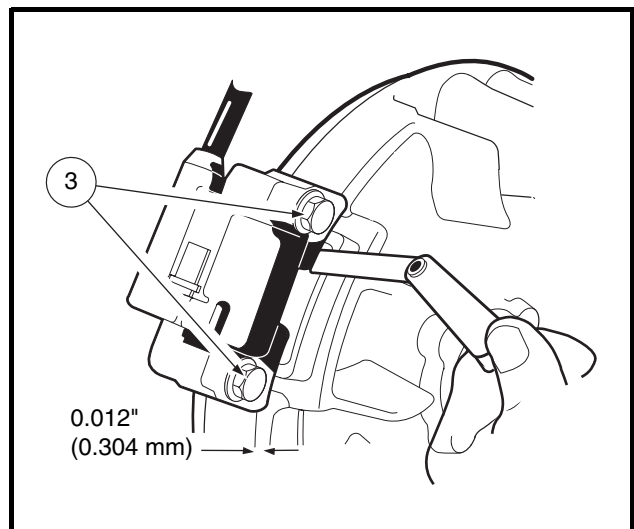

Figure 15-10 Adjust Ignition Coil Air Gap

Flywheel Installation

See Flywheel Installation on page 15-8.

Ignition Coil Inspection and Repair

See Test Procedure 16, Section 11, Page 11-23.

Ignition Coil Installation

1. Installation is the reverse of removal.
2. While tightening the two bolts (3), use a bronze feeler gauge to adjust the ignition coil air gap to 0.012 inch (0.304 mm) (Figure 15-10, Page 15-7).
3. Tighten the two ignition coil bolts to 30 in-lb (3.4 N·m).

Crankcase Cover Installation

See Crankcase Cover Installation on page 15-5.

FLYWHEEL INSTALLATION

1. Insert the flywheel key into the keyway in the crankshaft. Then align the keyway in the flywheel to the key and push the flywheel and fan assembly onto the crankshaft until it seats. Install flat washer and nut finger tight.
2. Use a strap wrench (3) to keep the flywheel and fan assembly (1) from turning while tightening the flywheel nut to 63 ft-lb (85.4 N·m) (Figure 15-11, Page 15-8). See following CAUTION.

⚠ CAUTION

- The flywheel nut has right-hand threads. Turn it clockwise to tighten, or counterclockwise to loosen.
 - Be careful not to damage the fan blades. Use a strap wrench to hold flywheel. Do not place screwdriver or pry bar between fan blades.
3. Install the fan housing and tighten the screws to 90 in-lbs (10 N·m).

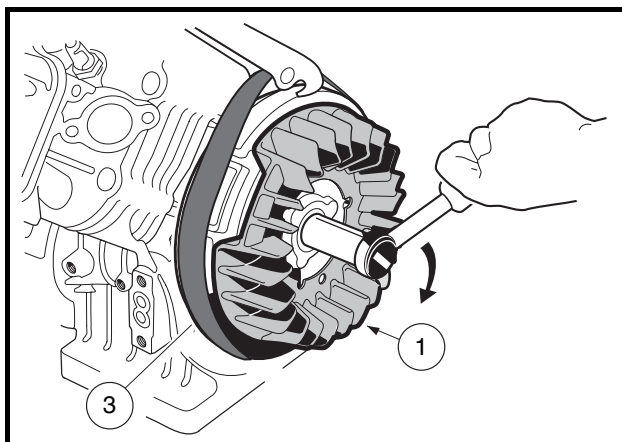

Figure 15-11 Fan and Flywheel Installation

ENGINE INSTALLATION

See General Warning on page 1-1.

1. Place engine onto engine mounting plate and tighten the mounting hardware (1, 2 and 5) to 13 ft-lb (17.7 N·m). Tighten nuts (6) to 17 ft-lb (23.1 N·m) (**Figure 15-4, Page 15-4**).
2. Install drive clutch. **See Drive Clutch Installation, Section 20, Page 20-12.**
3. Install drive belt. **See Drive Belt Installation, Section 20, Page 20-3.**
4. Install muffler. **See Muffler Installation, Section 17, Page 17-1.**
5. Install starter/generator and belt. **See Starter/Generator Installation, Section 13, Page 13-9.**
6. Install the powertrain. **See Unitized Transaxle Installation, Section 18, Page 18-13.**
7. Install oil drain plug in the crankcase and tighten to 20 ft-lb (27.1 N·m). Apply a light film of oil on the seal of a new oil filter and install the filter on the crankcase. Fill the crankcase to the proper level with the correct type of oil. This engine should be regarded as a new engine for next scheduled oil change. **See Section 10 – Periodic Maintenance.**
8. Check all hardware for proper torque/tightness.
9. Check engine oil level (**Figure 15-12, Page 15-9**).
 - 9.1. With vehicle on level surface, remove dip stick and clean with cloth (**Figure 15-12, Page 15-9**).
 - 9.2. Reinsert dip stick until fully seated.
 - 9.3. Oil must be in the SAFE LEVEL range.

⚠ CAUTION

- Do not overfill with oil.

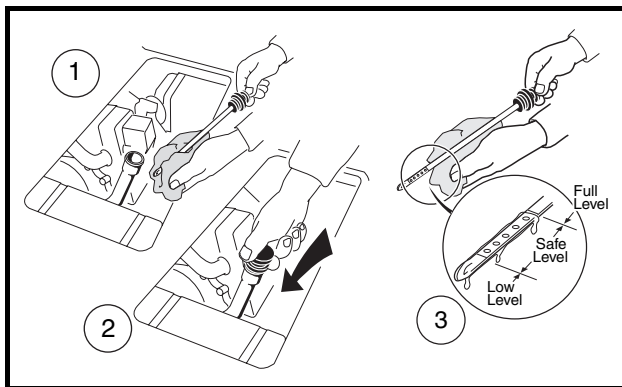

Figure 15-12 Check Engine Oil Level

10. Install a new or cleaned spark plug, gapped to 0.027-0.031 inch (0.686-0.787 mm), and connect plug wire to plug.
11. Connect battery cables, positive (+) cable first, and tighten hardware to 144 in-lb (16 N·m). **See Figure 1-1, Page 1-3.** Coat terminals with Battery Terminal Protector Spray (CCI P/N 1014305) to minimize corrosion.
12. Adjust the engine RPM setting. **See Engine RPM Adjustment on page 16-12.**
13. Test-drive vehicle to ensure all systems are functional and correctly adjusted.

TORQUE SPECIFICATIONS

ITEM	SIZE	LIMITS
Flywheel retaining nut	M16	63 ft-lb (86 N·m)
Crankcase cover to block bolts	M8	250 in-lb (28.3 N·m)
Starter/Generator bracket to block bolts	M8	200 in-lb (23 N·m)
Oil drain plug	M14	20 ft-lb (27.1 N·m)
Fan housing screws	M6	90 in-lb (10 N·m)
Fan shroud screws	M6	25 in-lb (2.8 N·m)
Bolts marked with "4" (when used with nuts)	M8	130 in-lb (15 N·m)
	M6	50 in-lb (5.9 N·m)
	M5	30 in-lb (3.4 N·m)

ADJUSTMENTS AND SETTINGS

ITEM	LIMITS
Spark plug gap (standard)	0.027 to 0.031 in. (0.69 to 0.79 mm)
Ignition coil air gap (standard)	0.012 in. (0.304 mm)
Compression pressure (min.)	156 psi (1076 kPa)
Engine RPM	2700 (±30) RPM

SECTION 16 – FUEL SYSTEM: GASOLINE VEHICLE

⚠ DANGER

- See General Warning on page 1-1.

⚠ WARNING

- See General Warning on page 1-1.

GENERAL INFORMATION

The engine is equipped with a float bowl type carburetor with fixed jets that require no adjustment. The carburetor atomizes the fuel, mixes it with air, and feeds the combustible mixture into the cylinder.

CARBURETOR

See General Warning on page 1-1.

Before suspecting the carburetor as the cause of poor engine performance, make sure the fuel and ignition systems are in proper operating condition. Check the following items:

- Spark plug and gap condition. **See Spark Plug, Section 15, Page 15-1.**
- Air filter element. **See Air Filter on page 16-16.**
- Fuel filters. **See Fuel Filters on page 16-17.**
- Choke and air intake system (for restriction of air flow). **See Choke and Air Intake System on page 16-12.**
- Fuel pump.
- Fuel lines (from fuel tank to filter to pump to filter to carburetor). **See Fuel Lines on page 16-25.**
- Exhaust system (for restrictions). **See Section 17 – Exhaust System: Gasoline Vehicles.**

If the carburetor floods or leaks fuel at the float bowl gasket or carburetor vent tube, the fuel inlet valve could be worn or dirty. Another cause of this condition may be a damaged float that has filled with fuel and sinks.

For elevations above 3000 feet, main jets other than standard operate more effectively. The following chart lists the elevation ratings for various jet sizes. No adjustment is required for the pilot jet. If the vehicle idles roughly, turn the pilot air screw out until the vehicle idles smoothly.

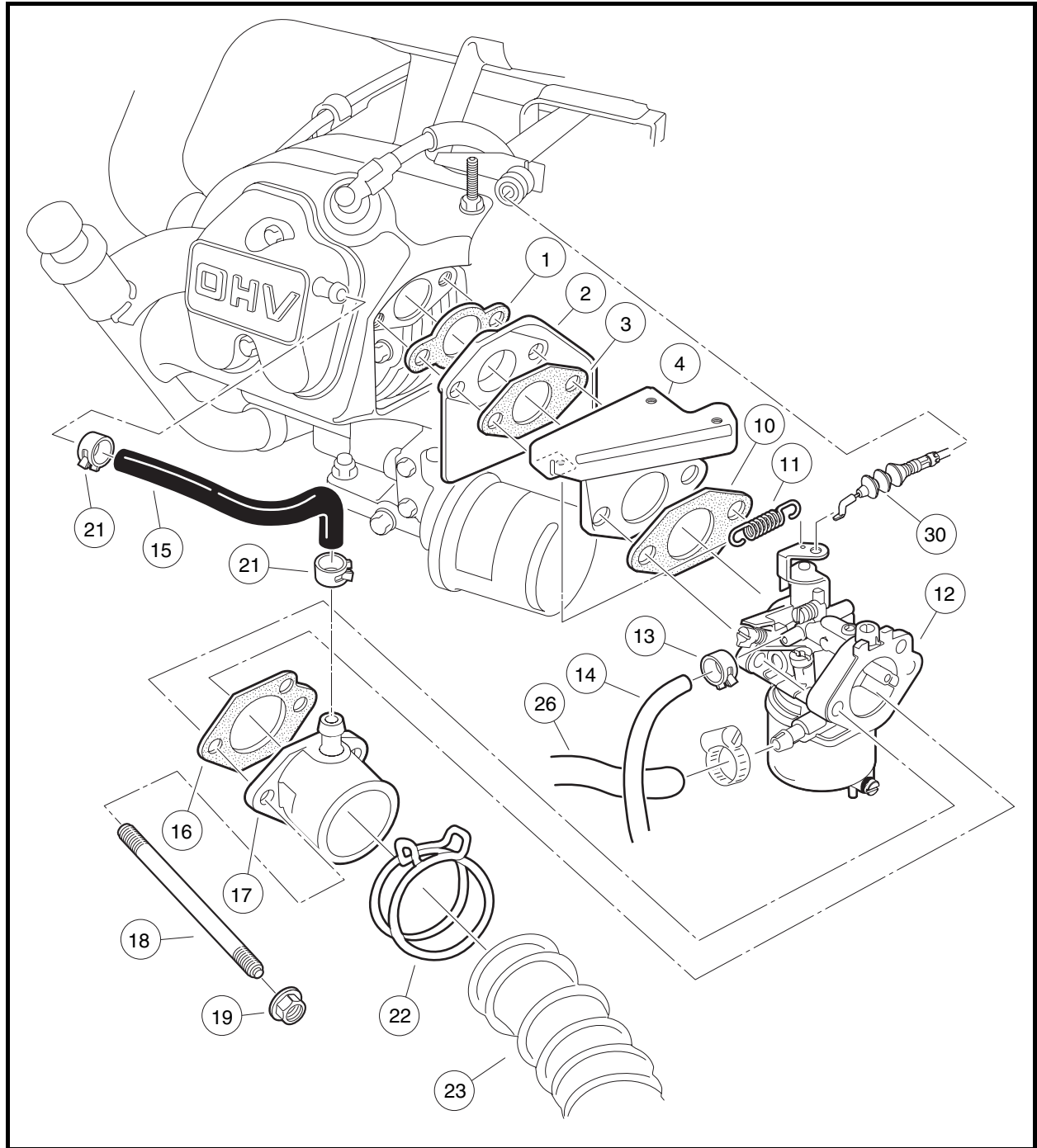

Figure 16-1 Carburetor Mounting

MAIN JET ELEVATION/SIZE CHART

ALTITUDE	FE290 ENGINE MAIN JET SIZE	FE350 ENGINE MAIN JET SIZE
0-3000 ft. (0-914.4 m)	82	85
3000-5000 ft. (914.4-1524 m)	80	82
5000-8000 ft. (1524-2438.4 m)	78	80
8000-10,000 ft. (2438.4-3048 m)	75	78
10,000 ft. and over (3048 m and over)	72	75

CHANGING THE MAIN JET

See General Warning on page 1-1.

1. Remove the carburetor.
 - 1.1. Turn fuel shut-off valve on fuel tank to the closed (OFF) position (**Figure 16-18, Page 16-25 or Figure 16-19, Page 16-25**).
 - 1.2. Loosen the intake air hose clamp (22) and disconnect the intake air hose (23) at the carburetor end only (**Figure 16-1, Page 16-2**).
 - 1.3. Remove the governor guard (5).
 - 1.4. Disconnect the governor cable (30) from the carburetor.
 - 1.5. Disconnect the carburetor vent line (14).
 - 1.6. Disconnect the fuel supply line (26) at the carburetor end only. Temporarily plug the end of the fuel line to prevent fuel leakage.
 - 1.7. Remove the carburetor retaining nuts (19), intake pipe (17), and carburetor (12). **See following NOTE.**

NOTE: Note the orientation of the gasket (16), between the carburetor intake pipe (17) and the carburetor body (12) so that it can be replaced in the same orientation (**Figure 16-1, Page 16-2**).

When removing the carburetor body, the throttle return spring (11) must be disconnected. Note its proper orientation so that it can be replaced in the same orientation.

The carburetor must be kept upright during removal.

2. Position the carburetor with the drain screw (11) over a catch basin (**Figure 16-4, Page 16-4**).
3. Turn the carburetor bowl drain screw counterclockwise two or three turns and drain all the fuel from the bowl into the catch basin (**Figure 16-2, Page 16-4**). Tighten the drain screw to 10 in-lb (1.1 N·m). Return fuel to the fuel tank or dispose of properly.
4. Mark the body of the carburetor and the carburetor fuel bowl with an indelible ink marker so that, after removal, the bowl can be installed again in the same position (**Figure 16-3, Page 16-4**).

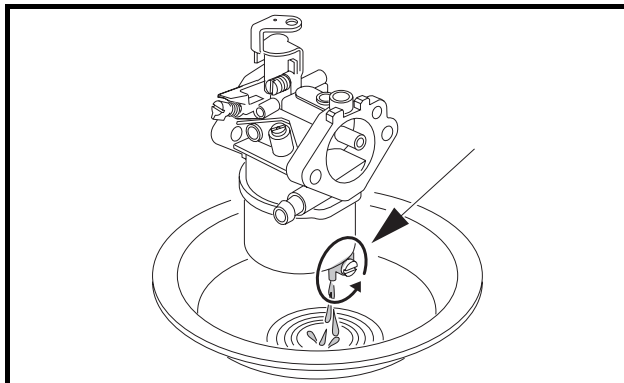

Figure 16-2 Drain Bowl

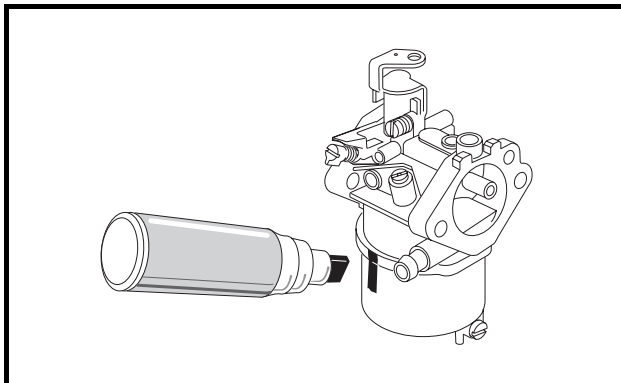

Figure 16-3 Mark Carburetor and Bowl for Alignment

- Remove the carburetor fuel bowl retaining screw and washer (12), then remove the fuel bowl (10) and clean it with a nonflammable solvent (Figure 16-4, Page 16-4). See following NOTE.

NOTE: Make sure the fuel bowl gasket (9) remains properly seated in the carburetor body when the fuel bowl is removed (Figure 16-4, Page 16-4).

During normal operation, the fuel bowl retains the float pivot pin (6). Make sure that the float pivot pin does not fall out of the carburetor body after the fuel bowl is removed.

- Remove the main jet (8) from the carburetor body and discard it (Figure 16-4, Page 16-4). See following NOTE.

NOTE: Make sure the fuel nozzle (7) does not fall out of the carburetor body after removal of the main jet. This is best accomplished by positioning the carburetor upside down during main jet removal (Figure 16-4, Page 16-4).

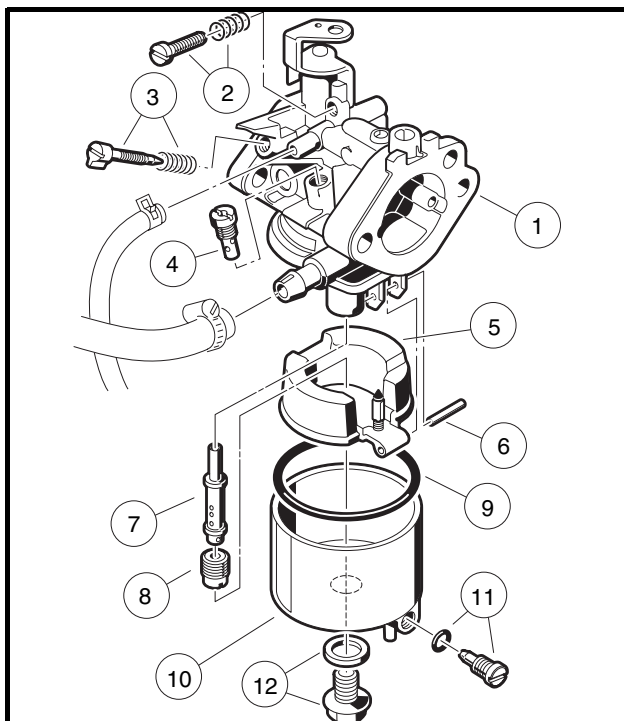

Figure 16-4 Carburetor Components

7. Select the proper size main jet. **See Main Jet Elevation/Size Chart on page 16-3.** Check the size designation on the jet to make sure it is the correct part.
8. Install the new main jet and tighten it to 12 in-lb (1.4 N·m). **See following CAUTION and NOTE.**

⚠ CAUTION

- Do not remove the valve/spring assembly from the float assembly. Doing so will damage the spring.

NOTE: Inspect the main jet nozzle (7), and pilot jet (4) to ensure they are free from contamination. Replace any part that is clogged with contamination. Replace the float if it is damaged, or if the float valve is damaged or worn. Examine the float valve/spring assembly to make sure the spring is installed correctly (**Figure 16-5, Page 16-5**).

9. Install the fuel bowl. Make sure that it is positioned properly by aligning the marks applied in step 4. **See following CAUTION.**

⚠ CAUTION

- Make sure the fuel bowl is properly seated against the carburetor fuel bowl gasket, and the gasket is not pinched.

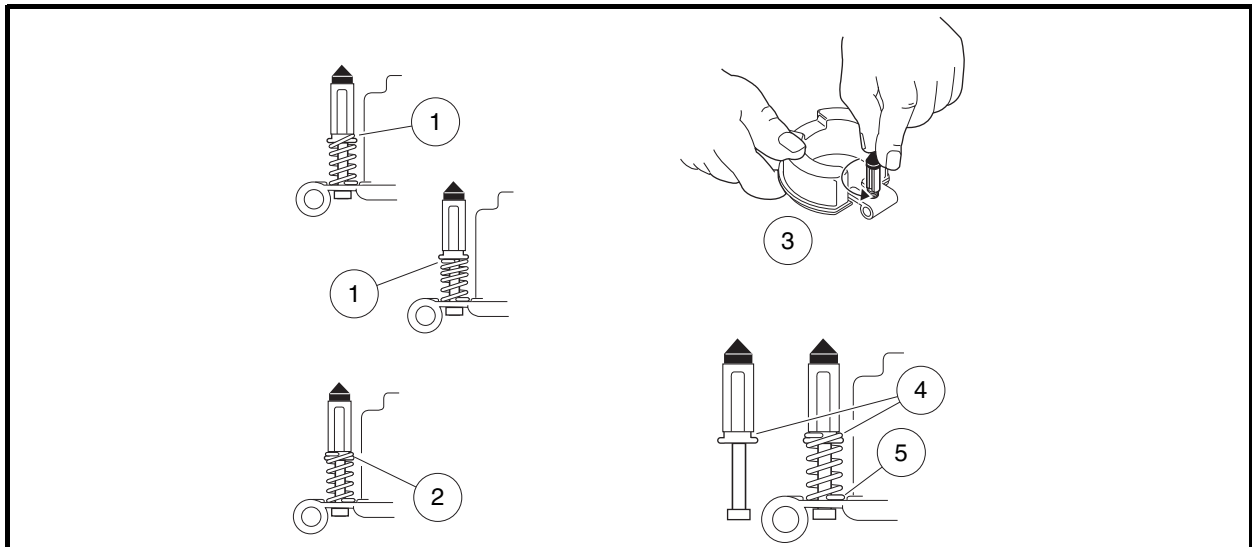

Figure 16-5 Inspect Float Valve/Spring Assembly – Adjust If Required

1. If spring looks like this... 2. then adjust spring to look like this by... 3. holding float firmly and rotating valve counterclockwise to seat spring in seat of float bowl 4. Check for coil located in groove above both ears. 5. Check for spring seated in recess of float.

10. Install the fuel bowl retaining screw and tighten it to 61 in-lb (6.9 N·m).
11. Write the size of the main jet on the fuel bowl with an indelible ink marker. This should be written in a location that will be visible when the carburetor is installed on the engine.
12. Install the carburetor on the engine (**Figure 16-1, Page 16-2**).
 - 12.1. Attach the throttle return spring (11) to the carburetor and then to the throttle bracket (4) just before positioning the carburetor and securing it to the engine (**Figure 16-1, Page 16-2**).

- 12.2. Install the intake pipe gasket (16) (check for proper orientation) and intake pipe (17).
- 12.3. Install the carburetor retaining nuts (19) and tighten them to 50 in-lb (5.7 N·m).
13. Connect fuel supply line (26) and tighten screw clamp to 9 in-lb (1.0 N·m) (**Figure 16-1, Page 16-2**).
14. Install carburetor vent line (14) and clamp (13).
15. Install the governor cable (30).
16. Install the governor guard (5), flat washer and nylon lock nut. Tighten to 30 in-lb (3.4 N·m).
17. Install the intake hose (23) and secure with hose clamp.

NOTE: Make sure the intake hose is not twisted during installation.

18. Turn fuel shut-off valve on top of fuel tank to the ON position (**Figure 16-18, Page 16-25 or Figure 16-19, Page 16-25**).
19. Connect battery cables, positive (+) cable first, and tighten hardware to 144 in-lb (16 N·m) (**Figure 1-1, Page 1-3**). Coat terminals with Battery Terminal Protector Spray (CCI P/N 1014305) to minimize corrosion.
20. Test drive the vehicle.

ENGINE CONTROL LINKAGE

See General Warning on page 1-1.

⚠ DANGER

- To ensure the vehicle does not run over you while you disconnect or adjust the accelerator push rod, do the following:
- Turn key switch OFF and remove key, place Forward/Reverse handle in the NEUTRAL position, and chock the wheels prior to servicing the vehicle.
 - Disconnect battery cables, negative (–) cable first.
 - Disconnect the spark plug wire from the spark plug.

GENERAL INFORMATION

For proper vehicle operation, it is important the accelerator pedal, governor linkage, and throttle adjustments are done correctly and in the proper sequence. **See following CAUTION.**

⚠ CAUTION

- Improper adjustment can result in poor vehicle performance and/or damage to the engine components.

ACCELERATOR ROD

Accelerator Rod Removal

1. Raise the front of the vehicle. Place chocks at the rear wheels and lift the front of the vehicle with a chain hoist or floor jack. Place jack stands under the round frame cross tube to support the vehicle. **See preceding DANGER. See also WARNING “Lift only one end of the vehicle...” in General Warning on page 1-1.**
2. Remove the accelerator rod by disconnecting the ball joint (1) from the ball stud (2) on the accelerator pedal (Figure 16-6, Page 16-7) and from the bell crank at the electrical box (Figure 16-8, Page 16-8).

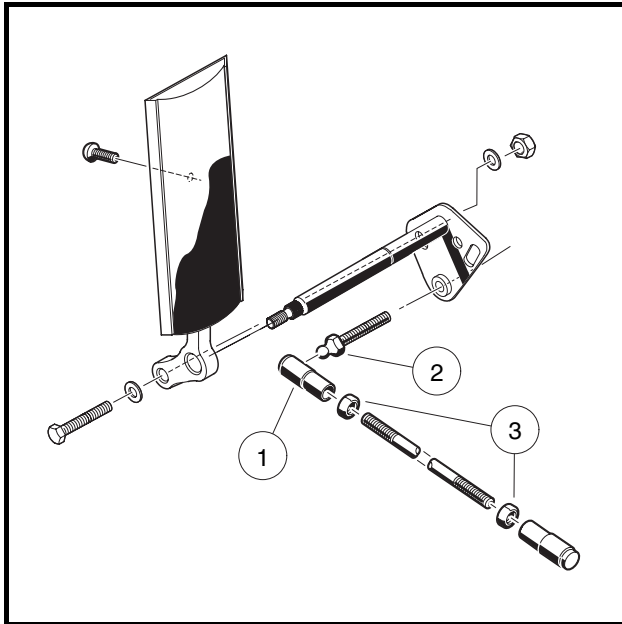

Figure 16-6 Accelerator Rod

Accelerator Rod Installation and Adjustment

1. Before installing the accelerator rod, adjust accelerator pedal position. **See Pedal Group Adjustment – Gasoline Vehicle on page 5-11.**
2. Install the ball joint on the ball stud at the accelerator pedal (Figure 16-6, Page 16-7).
3. Access the engine compartment.
4. Remove the electrical box screw and cover (Figure 16-7, Page 16-8).
5. Adjust length of accelerator rod. With the ball joint jam nuts (3) loose (Figure 16-6, Page 16-7), adjust the length of the accelerator rod so the indicated cam edge is parallel with the electrical component box as shown (Figure 16-7, Page 16-8). **See following CAUTION.**

▲ CAUTION

- **Be sure that approximately an equal number of threads are exposed at each end of the accelerator rod.**
6. Install the accelerator rod on the bell crank ball joint on the electrical component box (Figure 16-8, Page 16-8). **See following CAUTION and NOTE.**

⚠ CAUTION

- Inspect the limit switch inside the electrical box. If the limit switch lever is bent, replace the switch.

NOTE: Use the inside hole location, or hole closest to the bell crank shaft as shown (**Figure 16-8, Page 16-8**).

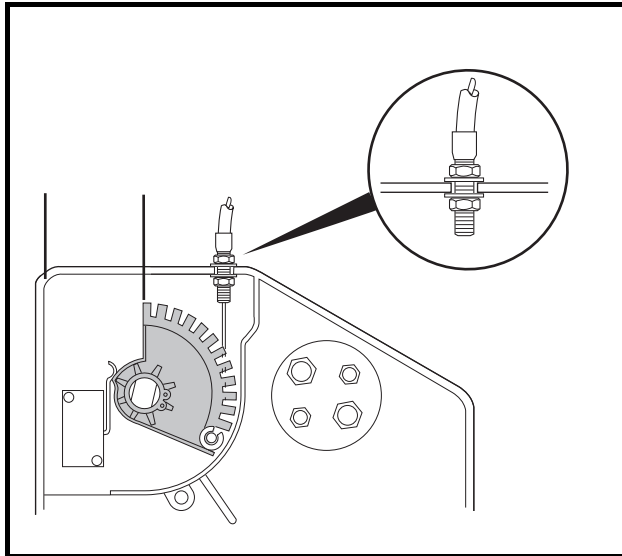

Figure 16-7 Cam Position – Parallel with Box (Top View)

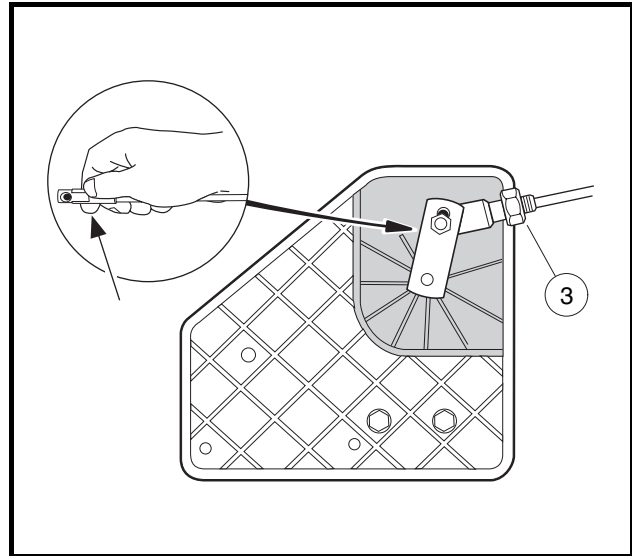

Figure 16-8 Accelerator Rod – Pull Spring Release to Attach (Bottom View)

7. Before tightening the jam nuts, set the park brake to the first latch and pawl position and check for proper activation of switches.
8. While pressing the accelerator pedal, the following events should occur in exactly the order shown:

EVENT	APPROXIMATE PEDAL TRAVEL
Park brake release	0°-4°
Solenoid activation	4°-8°
Carburetor throttle actuation	8°-12°

9. While holding the accelerator ball joint with pliers, tighten the jam nuts against the ball joints, accelerator ball joint first, at each end of the accelerator rod.
10. Check rod adjustment for proper switch activation.
11. After the pedal group and accelerator rod are properly adjusted, adjust the engine RPM setting. **See Engine RPM Adjustment on page 16-12.**
12. Install the electrical box cover and tighten retaining screw to 18 in-lb (2.0 N·m).
13. Connect battery cables, positive (+) cable first, and tighten hardware to 144 in-lb (16 N·m) (**Figure 1-1, Page 1-3**). Coat terminals with Battery Terminal Protector Spray (CCI P/N 1014305) to minimize corrosion.

GOVERNOR CABLE

Governor Cable Removal

1. Turn the key switch to the OFF position and remove the key, place the Forward/Reverse handle in the NEUTRAL position, and chock the wheels.
2. Access the engine compartment.
3. Disconnect battery cables as instructed. **See WARNING “To avoid unintentionally starting...” in General Warning on page 1-1.**
4. Remove the governor guard (5) (**Figure 16-1, Page 16-2**).
5. Disconnect the governor cable (2) at the carburetor throttle.
6. Disconnect the governor cable (2) from the governor lever arm (15) (**Figure 16-9, Page 16-10**).
7. Remove the governor cable (2) from the governor cable engine bracket (11), and governor cable support bracket (10) (**Figure 16-9, Page 16-10**). Remove the cable (2) from the vehicle.

Governor Cable Installation and Adjustment

1. Install the cable onto the governor cable support bracket (10) and the engine bracket (11) (**Figure 16-9, Page 16-10**).
2. Push the cable dust shields onto the ends of the cable conduit.
3. Connect the governor cable to the carburetor throttle at the carburetor.
4. Connect the governor cable to the governor lever arm (15) (**Figure 16-9, Page 16-10**).
5. With the governor lever arm loose on the governor shaft, use a 1/8-inch punch or scratch awl to turn the governor arm shaft counterclockwise until it stops. Then pull the governor lever arm rearward until the carburetor throttle is in the “wide open throttle” (WOT) position.
6. While holding the arm and shaft in the fully counterclockwise position, tighten the governor arm lever nut to 36 in-lb (4.0 N·m).
7. Check engine RPM adjustment. **See Engine RPM Adjustment on page 16-12.**

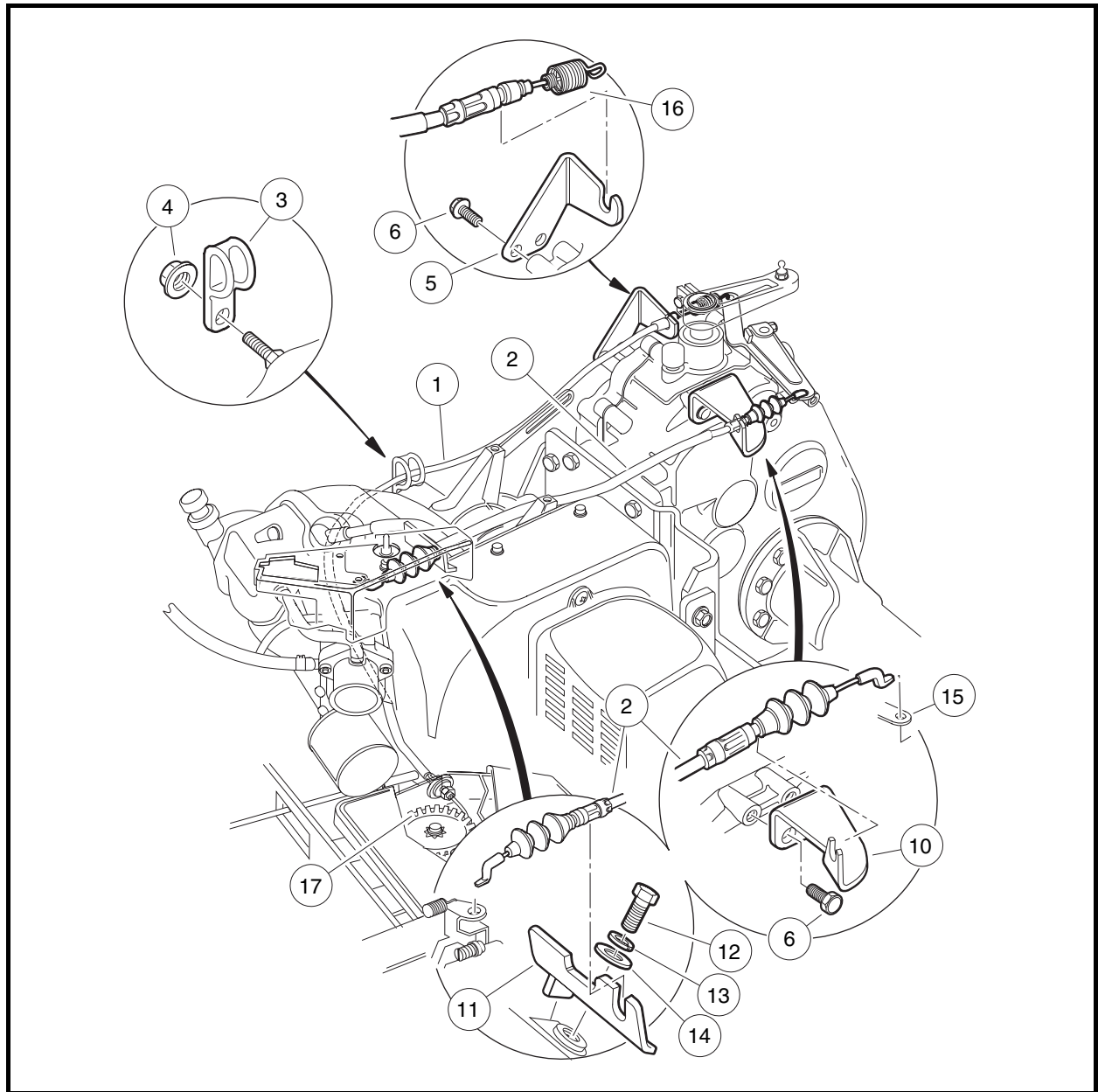

Figure 16-9 Governor and Accelerator Cables

ACCELERATOR CABLE

Accelerator Cable Removal

1. Access the engine compartment.
2. Remove the electrical box screw and cover and loosen the cable housing retaining nuts (**Figure 16-7, Page 16-8**).
3. Disconnect cable (1) from cam (17) in the electrical box (**Figure 16-9, Page 16-10**).
4. Disconnect the spring (16) from the engine governor arm.
5. Remove the accelerator cable from the accelerator cable bracket (5). Remove the cable assembly from the vehicle.

Accelerator Cable Installation

1. Connect the cable to the cam (17) in the electrical box (**Figure 16-9, Page 16-10**).
2. Insert the cable housing into the mounting slot in the wall of the electrical box, with approximately the same number of threads visible between the jam nuts as are visible from the nut inside the box to the end of the cable housing (**Figure 16-7, Page 16-8**). Tighten the nuts finger-tight.
3. Connect the spring (16) to the engine governor arm (**Figure 16-9, Page 16-10**).
4. Install cable in accelerator cable bracket (5) (**Figure 16-9, Page 16-10**).
5. Push the cable dust shield onto the spring end of the cable conduit.
6. Before tightening the cable housing retaining nuts, make sure the engine RPM adjustment is correct. **See Engine RPM Adjustment on page 16-12.**
7. Install the electrical box cover, and tighten the retaining screw to 18 in-lb (2.0 N·m).
8. Connect battery cables, positive (+) cable first, and tighten hardware to 144 in-lb (16 N·m) (**Figure 1-1, Page 1-3**). Coat terminals with Battery Terminal Protector Spray (CCI P/N 1014305) to minimize corrosion.

CLOSED THROTTLE OR IDLE ADJUSTMENT

When the accelerator pedal is released, the engine will stop. Therefore, it is not possible to measure or set idling speed under normal vehicle operating conditions. Set throttle valve as follows:

1. Loosen the carburetor idle screw so that it is not touching the throttle lever (**Figure 16-10, Page 16-11**).
2. Slowly tighten the idle screw until it lightly touches the throttle lever, then tighten it an additional 3/4 turn.

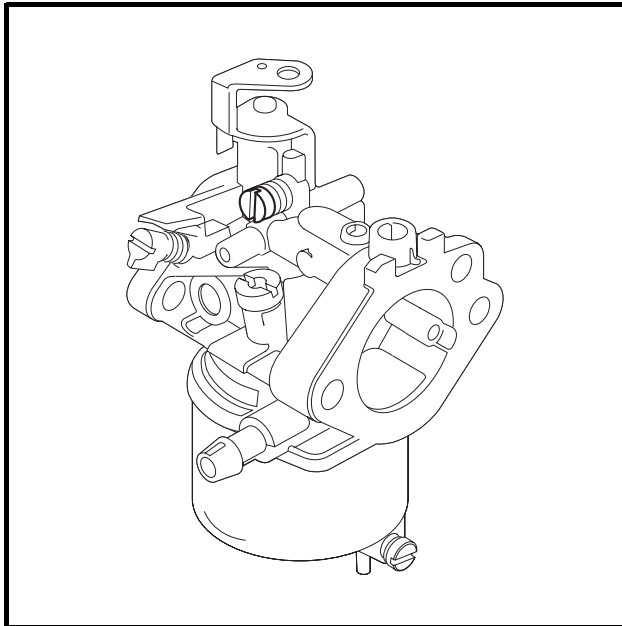

Figure 16-10 Idle Screw

ENGINE RPM ADJUSTMENT

DANGER

- **Do not operate gasoline vehicle in an enclosed area without proper ventilation. The engine produces carbon monoxide, which is an odorless, deadly poison.**
1. If the governor is adjusted, proceed to step 2; otherwise, adjust the governor. **See Governor Cable Installation and Adjustment on page 16-9.**
 2. Connect battery cables, positive (+) cable first, and tighten hardware to 144 in-lb (16 N·m) (**Figure 1-1, Page 1-3**). Coat terminals with Battery Terminal Protector Spray (CCI P/N 1014305) to minimize corrosion.
 3. **XRT 800/810:** Place the Forward/Reverse handle in the NEUTRAL position and chock the wheels.
 4. **XRT 850:** Place the Forward/Reverse handle in the NEUTRAL position, chock the wheels, and the neutral lockout switch in the MAINTENANCE position.
 5. Connect a tachometer (CCI P/N 1016112) to the spark plug lead.
 6. With the tachometer connected, and the engine at normal operating temperature, check high speed RPM. With the accelerator pedal pressed to the floor, the tachometer should read 3300 ±30 RPM (800/810) or 2600 ±30 RPM (850).
 7. To reduce RPM, loosen the accelerator cable retaining nut on the outside of the electrical box wall and tighten the retaining nut on the inside of the wall until the specified RPM is reached (**Figure 16-7, Page 16-8**). To increase RPM, loosen the cable retaining nut inside the electrical box and tighten the nut outside the box until the specified RPM is reached.
 8. Be sure both retaining nuts are locked against the electrical box and then check the RPM again. If the RPM needs to be adjusted, repeat step 7.
 9. If more adjustment is required than the cable housing will allow, make sure the spring on the other end of the accelerator cable is properly positioned. Excessive belt and torque converter wear can also prevent proper RPM adjustment. Check them for excessive wear. **See Section 20 – Torque Converter: Gasoline Vehicle.**

CHOKE AND AIR INTAKE SYSTEM

See General Warning on page 1-1.

CHOKE BUTTON REMOVAL

1. Remove the mounting screws (22) from the back side of the choke. Remove the choke assembly from the vehicle body (**Figure 16-12, Page 16-15**).

CHOKE BUTTON INSTALLATION

1. Position the choke assembly (2) on the vehicle body. Install the mounting screws (22) from inside the vehicle body and tighten to 18 in-lb (2.0 N·m) (**Figure 16-12, Page 16-15**).

2. Check for proper operation. If the choke button does not adequately engage the choke lever (20), loosen the screw (30) and adjust the choke bracket (23) on the choke lever (20). Move the bracket toward the choke button to increase choke engagement and away from the choke button to reduce choke engagement.

AIR BOX REMOVAL

1. Turn the key switch to the OFF position and remove the key, place the Forward/Reverse handle in the NEUTRAL position, and chock the wheels.
2. Disconnect the battery cables as instructed. **See WARNING “To avoid unintentionally starting...” in General Warning on page 1-1.**
3. Remove the air intake box from the vehicle by removing intake hose (21) and three screws (1) and washers (29) that mount the intake box to the vehicle (**Figure 16-12, Page 16-15**).

AIR BOX INSTALLATION

NOTE: The intake duct must be in place before the air box can be installed.

1. Check to be sure the intake seal (11) is seated correctly (**Figure 16-12, Page 16-15**). The seal fits tightly onto the bottom side of the air box. If seal is not in place, moisture will enter the air intake system.
2. Place the air box assembly into vehicle and install three flat washers (29) and screws (1) from underside of air box mounting plate into air box (**Figure 16-12, Page 16-15**). Tighten to 33 in-lb (3.7 N-m).
3. Place hose onto air box and secure with wire clamp. If equipped with screw clamp, tighten to 17 in-lb (1.9 N-m).
4. Test choke for proper operation.

INTAKE DUCT REMOVAL

1. Remove the front body. **See Front Body Removal, Section 4, Page 4-3.**
2. Remove the front left wheel. **See Wheel Removal, Section 8, Page 8-1.**
3. Remove the steering joint assembly (**Figure 16-11, Page 16-13**).

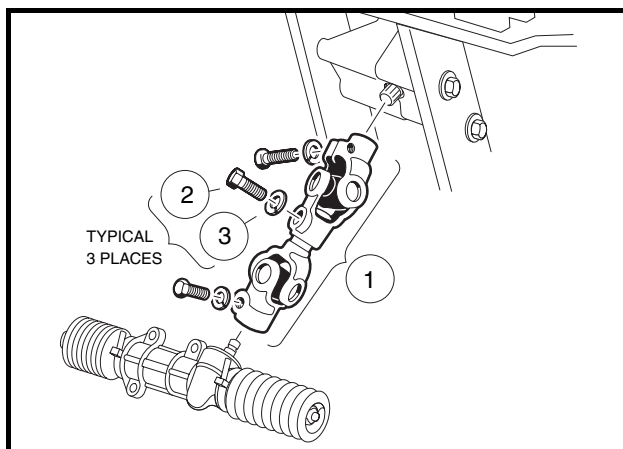

Figure 16-11 Compound Steering Joint

4. Drill out the two pop rivets (27) securing the intake duct to the floorboard (**Figure 16-12, Page 16-15**).

5. Remove three screws (1) and flat washers (29) from the bottom of the air box assembly.
6. Lift air box assembly off the intake duct. Be careful that the intake seal on the bottom of the air box assembly is not dislodged in the process.
7. Pull the intake duct forward and out of the vehicle.

INTAKE DUCT INSTALLATION

The intake duct assembly is installed from the front of the vehicle.

1. Slide the intake duct between the round crossmember and the floorboard, moving it to the rear along the underside of the floorboard. Insert the end of the intake duct through the slot in the front of the air box mounting plate.
2. Secure the front of the duct to the underside of the floorboard with two pop rivets (27) and flat washers (28) (**Figure 16-12, Page 16-15**).
3. Install air box. **See Air Box Installation on page 16-13.**
4. Install steering joint assembly. **See following NOTE.**

NOTE: Make sure steering wheel and front wheels are properly aligned before installing steering joint.

- 4.1. Position steering joint assembly (1) on vehicle as shown. Install three lock washers (3) and three bolts (2) and tighten to 15 ft-lb (20.3 N·m) (**Figure 16-11, Page 16-13**).
- 4.2. Align the flat portion of the steering shaft spline with the bolt hole in the universal joint and then slide the shaft into the upper universal joint. Install the bolt and lock washer on the upper universal joint and tighten to 15 ft-lb (20 N·m).
5. Install front left wheel. Tighten the lug nuts to 55 ft-lb (75 N·m) for vehicles with steel wheels. For XRT 850 vehicles with alloy mag wheels, tighten the lug nuts to 65 ft-lb (88 N·m).
6. Install front body.

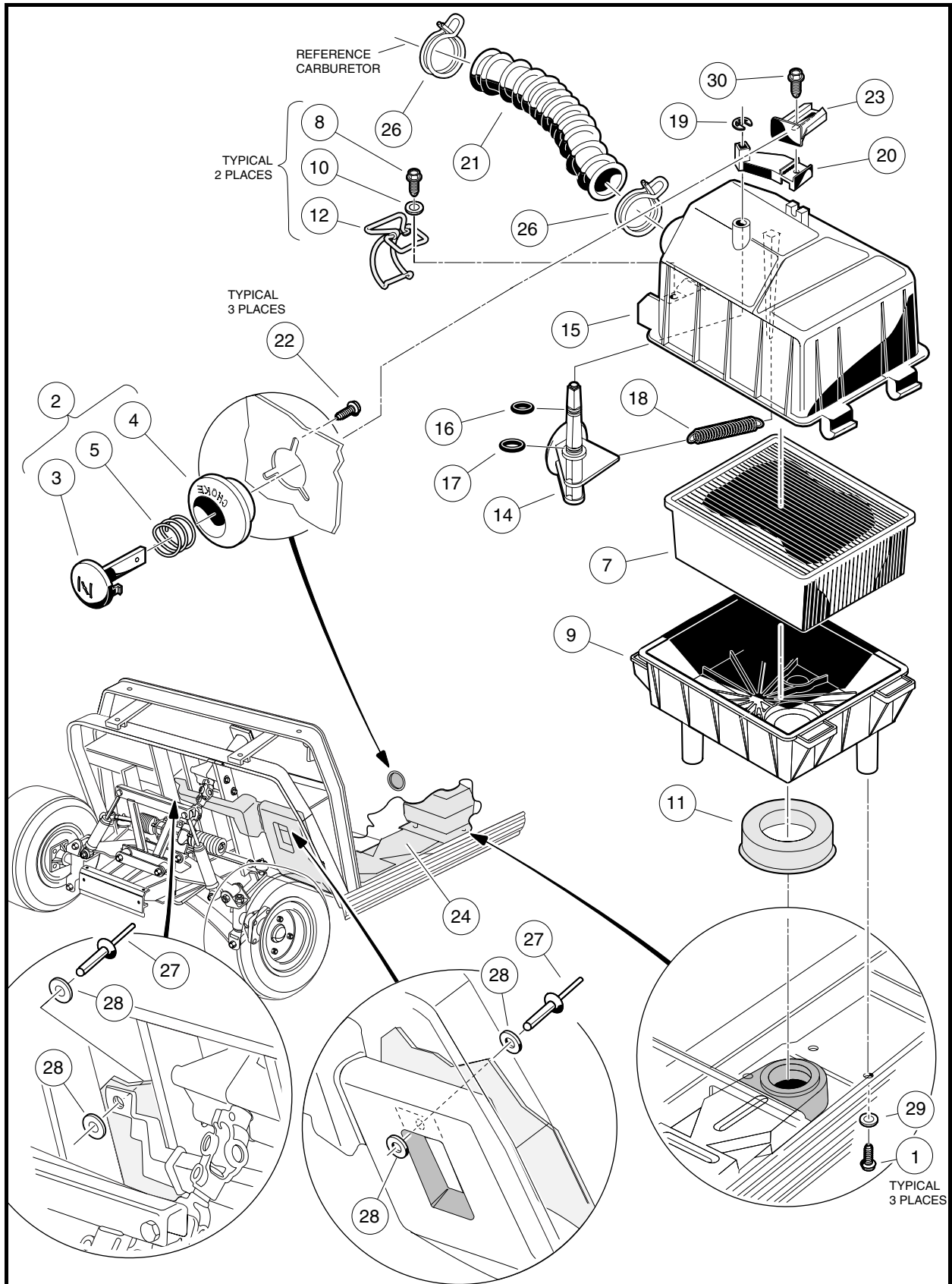

Figure 16-12 Air Intake and Choke Assemblies

AIR FILTER

General Information

The air filter should be checked every year or 100 hours. More frequent service may be required in extremely dirty operating environments. Need for immediate servicing will be indicated by a loss of power, sluggish acceleration, or an engine which runs roughly with excessive black exhaust smoke.

Air Filter Replacement

1. Lift two latches (12) on the side of the air box (**Figure 16-12, Page 16-15**).
2. Remove the hose clamp (26) from the air hose (21) and remove hose from the air box assembly.
3. Standing on driver side of vehicle, grasp air hose mounting inlet and open box fully. Remove filter element (7).
4. Using a clean cloth, wipe away any dust or dirt from inside the air box. Remove all dirt build-up around the inside lip of the box or the box will not seal properly.
5. Install new air filter by inserting back edge first, and pushing down using the palm of your hand to seat filter evenly onto inside lip of air box. Ensure filter fits correctly and that the wire latches are not caught between lid and air box. Close the lid.
6. Fasten wire latches (12). Make sure latches securely engage the bottom half of the box. **See following CAUTION.**

⚠ CAUTION

- Engine damage will occur if the air box cover is not properly secured.
 - If air box is extremely dirty, remove air box from vehicle and clean thoroughly.
 - Use only Club Car replacement air filters (CCI P/N 1015426). The use of other air filters could result in engine damage. If the air filter is too thin, the cover will seat before the filter can seal, leaving space for dirt to pass into the engine on all sides of the element. This will damage the engine and void the warranty.
7. Install hose (21) and hose clamp (26) (**Figure 16-12, Page 16-15**). If equipped with screw clamp, tighten to 17 in-lb (1.9 N·m). Make sure clamp ends are located in the 12:00 o'clock position.

FUEL FILTERS

See **General Warning** on page 1-1.

FUEL FILTER REMOVAL

1. Turn the key switch to the OFF position and remove the key, place the Forward/Reverse handle in the NEUTRAL position, and chock the wheels.
2. Disconnect battery cables as instructed. See **WARNING “To avoid unintentionally starting...”** in **General Warning** on page 1-1.
3. To prevent fuel drainage, turn the fuel shut-off valve (15) (**Figure 16-13, Page 16-18**) on the fuel tank to the closed (OFF) position (**Figure 16-18, Page 16-25** or **Figure 16-19, Page 16-25**).
4. Remove the primary fuel filter (17) (**Figure 16-13, Page 16-18**).
 - 4.1. Remove the clamps (16) and fuel lines (1 and 2) from the filter and plug the fuel lines.
5. Remove the secondary filter (22).
 - 5.1. Remove the clamps (16) and fuel lines (3 and 4) from the filter and plug the fuel lines (3 and 4).

FUEL FILTER INSTALLATION

⚠ CAUTION

- Fuel filters are marked with flow direction arrows. Make sure that filters are installed with arrows pointing in the direction of fuel flow from tank to carburetor.

1. Install the primary fuel filter (17) in the fuel line. Use new clamps (16) (**Figure 16-13, Page 16-18**).
2. Install the secondary fuel filter (22) in the fuel line. Use new clamps (16).
3. Turn the fuel shut-off valve to the ON position (**Figure 16-18, Page 16-25** or **Figure 16-19, Page 16-25**).
4. Connect the spark plug wire to the spark plug.
5. Connect battery cables, positive (+) cable first, and tighten hardware to 144 in-lb (16 N·m) (**Figure 1-1, Page 1-3**). Coat terminals with Battery Terminal Protector Spray (CCI P/N 1014305) to minimize corrosion.
6. **XRT 800/810:** Place the Forward/Reverse handle in the NEUTRAL position and chock the wheels. See following **DANGER**.
7. **XRT 850:** Place the Forward/Reverse handle in the NEUTRAL position, chock the wheels, and the neutral lockout switch in the MAINTENANCE position. See following **DANGER**.

⚠ DANGER

- Repair all fuel leaks before operating the vehicle.
8. Start the engine and check for fuel leaks.

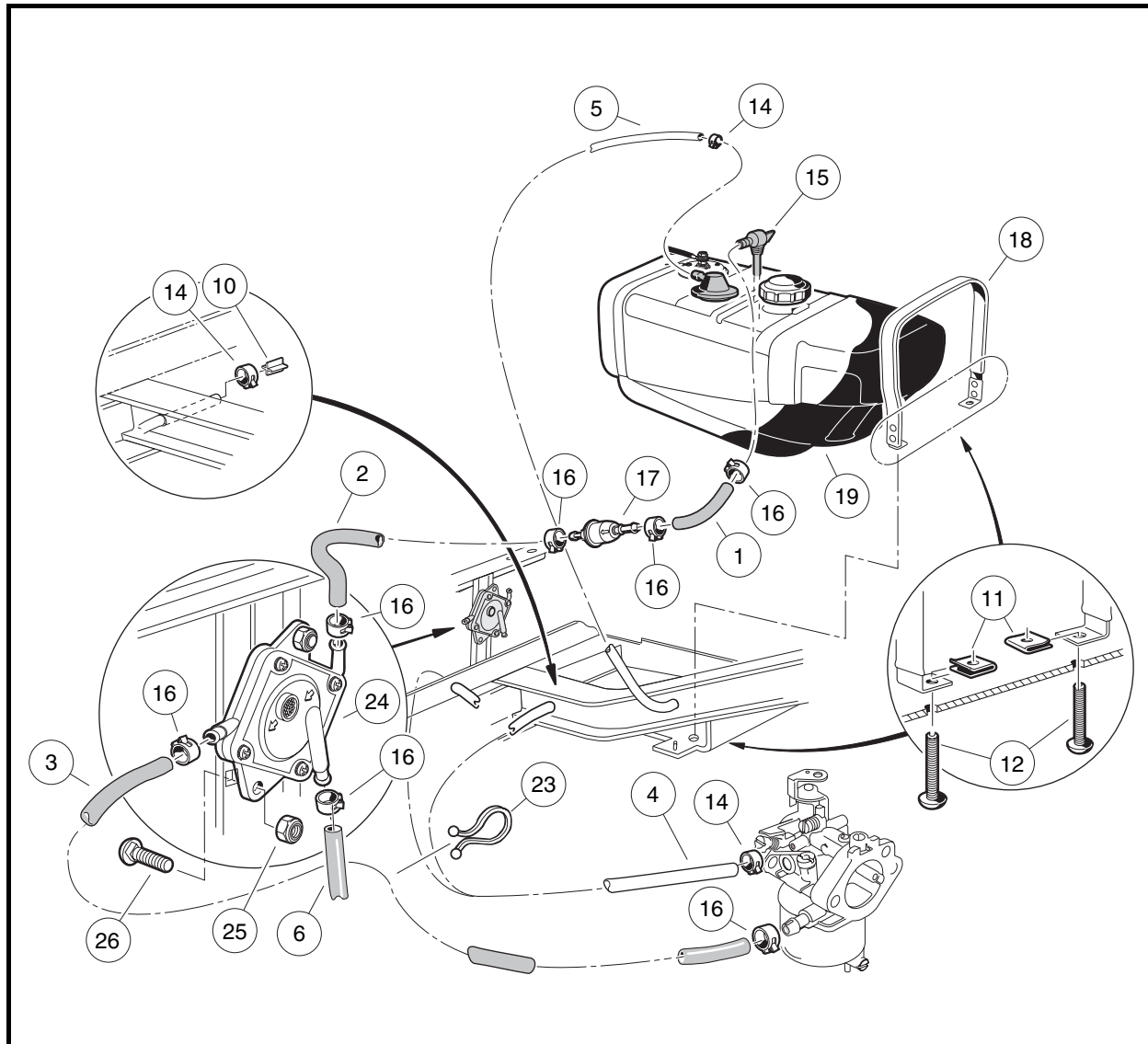

Figure 16-13 Fuel and Vent Lines

FUEL LINE NO.	ROUTING	LENGTH	
		SOLID COLOR	CLEAR
1	Fuel tank to primary fuel filter	7.0 in. (17.8 cm)	
2	Primary fuel filter to fuel pump	6.5 in. (16.5 cm)	
3	Fuel pump to carburetor	17.0 in. (43.2 cm)	
4	Vent tube (Carburetor)		11.0 in. (27.9 cm)
5	Vent tube (Gas Tank)		18.0 in. (45.7 cm)
6	Impulse line	16.0 in. (43.2 cm)	
	Total:	46.5 in. (118.1 cm)	29.0 in. (99.1 cm)

FUEL PUMP

See General Warning on page 1-1.

GENERAL INFORMATION

The gasoline vehicle is equipped with an impulse fuel pump. If the fuel pump is not operating properly, perform the following tests:

- Make sure all hose clamps are tight.
- Inspect the impulse line and fuel lines for damage or clogging.
- Make sure the air vent on the fuel pump is not clogged with dirt.
- Make sure the fuel filters are not clogged.

To clean the air vent, the fuel pump must be disassembled.

FUEL PUMP REMOVAL

1. Turn the key switch to the OFF position and remove the key, place the Forward/Reverse handle in the NEUTRAL position, and chock the wheels.
2. Disconnect the battery cables as instructed. **See WARNING “To avoid unintentionally starting...” in General Warning on page 1-1.**
3. Turn fuel shut-off valve on top of the fuel tank to the closed (OFF) position (**Figure 16-18, Page 16-25 or Figure 16-19, Page 16-25**).
4. Remove hardware attaching the fuel pump (24) and lift the fuel pump out of the engine compartment (**Figure 16-13, Page 16-18**).
5. Remove the clamp and impulse line (7) from fuel pump.
6. Disconnect the fuel lines (2 and 3) from the pump and plug them to prevent fuel leakage. **See following WARNING.**

⚠ WARNING

- Carefully drain any fuel remaining in the pump into an approved container. Add drained fuel back into fuel tank or dispose of properly.

FUEL PUMP DISASSEMBLY

⚠ CAUTION

- Fuel pump gaskets and diaphragms must be installed in exactly the same positions and orientations they were in before disassembly, or the pump could leak. If leaking occurs, all new gaskets and diaphragms must be installed.

NOTE: A fuel pump rebuild kit is available from your distributor/dealer (CCI P/N 1014524). This kit includes all gaskets, diaphragms, and valves.

1. Match mark the fuel pump and cover before disassembly.
2. Remove four screws (24) and lock washers (25) from front of the fuel pump (**Figure 16-14, Page 16-20**).
3. Remove the front cover of the fuel pump while holding the rest of the pump intact.

- Note the orientations of the impulse gasket (27), the diaphragm (28), and the gasket (29), then remove them from the pump.
- If the impulse gasket (27) and the diaphragm (28) come off with the front cover, note their orientations and remove them (**Figure 16-14, Page 16-20**).
- Remove the pumping chamber (30).
- Remove the back cover (36), the fuel diaphragm (34), and gasket (35) (**Figure 16-14, Page 16-20**).

FUEL PUMP CLEANING AND INSPECTION

- Using a nonflammable solvent, clean the front cover, pumping chamber, and back cover. Be sure the vent on the front cover is clean both inside and out.
- Inspect the valve assemblies (31, 32, and 33) and all gaskets and diaphragms for damage (**Figure 16-14, Page 16-20**).
- If a valve assembly is damaged, the rubber retaining plug (33) and valve assembly must be replaced.

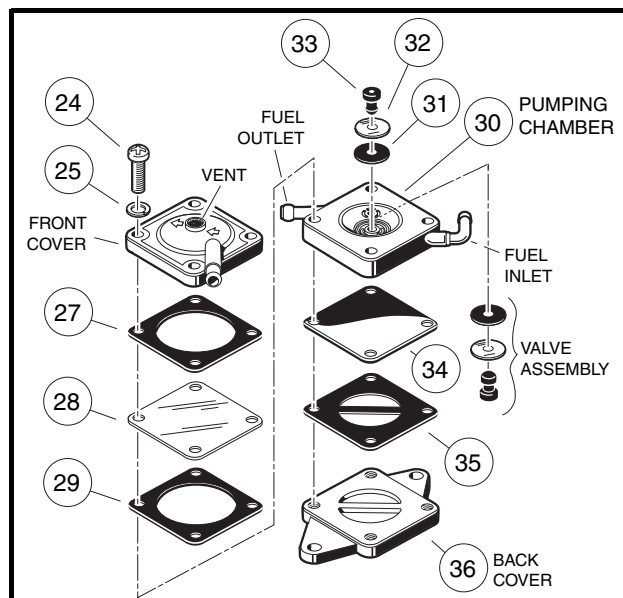

Figure 16-14 Fuel Pump

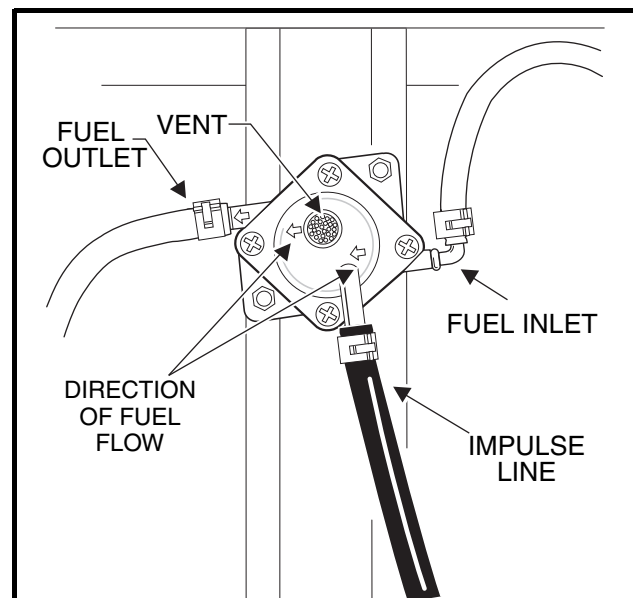

Figure 16-15 Fuel Pump Orientation

FUEL PUMP ASSEMBLY

- Install the fuel gasket (35) and diaphragm (34) on the back cover (36) (**Figure 16-14, Page 16-20**).
- Install the valve assembly in the pumping chamber (30). **See following CAUTION.**

CAUTION

- If the valve assembly is not installed exactly as shown (**Figure 16-14, Page 16-20**), the impulse fuel pump will not operate properly.
- Install the pumping chamber (30) on top of the fuel diaphragm (34). Be sure the fuel inlet and the fuel outlet align with the arrows on the front of the front cover (**Figure 16-14, Page 16-20**).
 - Install the gasket (29), clear impulse diaphragm (28), and the paper impulse gasket (27) to the pumping chamber (30).

5. Install the front cover and then the lock washers (25) and four screws (24) on the assembly (**Figure 16-14, Page 16-20**). Be sure the arrows on the front cover point from the fuel inlet to the fuel outlet (**Figure 16-15, Page 16-20**). Tighten the screws to 26 in-lb (3.0 N·m).

FUEL PUMP INSTALLATION

1. Connect to the fuel pump the fuel line (2) that comes from the primary fuel filter (17). Install a new clamp (16). Route the fuel lines as shown (**Figure 16-13, Page 16-18**).

NOTE: Be sure to connect the fuel line (2), that comes from the primary fuel filter (17), to the inlet nipple on the pump. Direction of fuel flow is indicated by the arrows on the fuel pump (**Figure 16-13, Page 16-18**). See also **Figure 16-15, Page 16-20**.

2. Connect to the output side of the fuel pump, the fuel line (3) that goes to the secondary fuel filter.
3. Connect the impulse line (7) to the bottom nipple on the fuel pump. Use a new clamp (16).
4. Install the fuel pump. Tighten nylon lock nuts to 38 in-lb (4.3 N·m).
5. Connect battery cables, positive (+) cable first, and tighten hardware to 144 in-lb (16 N·m). See **Figure 1-1, Page 1-3**. Coat terminals with Battery Terminal Protector Spray (CCI P/N 1014305) to minimize corrosion.
6. Turn the fuel shut-off valve on top of the fuel tank to the open position (**Figure 16-18, Page 16-25** or **Figure 16-19, Page 16-25**).
7. **XRT 800/810:** Place the Forward/Reverse handle in the NEUTRAL position and chock the wheels. See following **DANGER**.
8. **XRT 850:** Place the Forward/Reverse handle in the NEUTRAL position, chock the wheels, and the neutral lockout switch in the MAINTENANCE position. See following **DANGER**.

DANGER

- Repair all fuel leaks before operating the vehicle.

9. Start the engine and check for fuel leaks. If the fuel pump leaks, a rebuild kit must be installed to replace all gaskets and diaphragms.

FUEL TANK

See General Warning on page 1-1.

GENERAL INFORMATION

The vehicle is equipped with a high impact plastic, seven gallon (26.5 liter) fuel tank.

WARNING

- If the fuel tank is damaged, replace it. Do not attempt to repair it. See the following tank removal and disposal procedure.

⚠ CAUTION

- Add only unleaded fuel to the tank. Do not put oil in the fuel tank.

FUEL TANK REMOVAL

1. Remove the cargo bed, rear body and seat back support. **See Cargo Bed Removal, Section 4, Page 4-8.**
2. **XRT 800/810:** Place the Forward/Reverse handle in the NEUTRAL position and chock the wheels.
3. **XRT 850:** Place the Forward/Reverse handle in the NEUTRAL position, chock the wheels, and the neutral lockout switch in the MAINTENANCE position.
4. Turn fuel shut-off valve to the closed (OFF) position and run the engine until fuel remaining in the carburetor, fuel pump, and fuel lines is used up and the engine stalls (**Figure 16-18, Page 16-25 or Figure 16-19, Page 16-25**).
5. Disconnect the battery cables as instructed. **See WARNING “To avoid unintentionally starting...” in General Warning on page 1-1.**
6. Loosen, but do not remove, the carburetor drain screw (11) and drain fuel remaining in the carburetor bowl into an approved container (**Figure 16-4, Page 16-4**). Retighten carburetor drain screw.
7. Using a siphon with a suction device, siphon all fuel out of the tank and into an approved container. **See following DANGER and WARNING.**

⚠ DANGER

- Gasoline – Flammable! Explosive! Do not smoke. Keep sparks and flames away from the vehicle and service area. Service only in a well-ventilated area.

⚠ WARNING

- Do not attempt to siphon fuel using a hose that does not have a built-in suction device.
 - Do not attempt to siphon fuel using your mouth.
8. If vehicle is equipped with a fuel gauge, disconnect the black wire and orange wire from the fuel level sending unit on the tank (**Figure 16-16, Page 16-23**). Do not remove the lower nut on the center stud of the sending unit. **See following WARNING.**

⚠ WARNING

- Make sure the key switch is off before disconnecting wiring.
9. Remove the vent tube (6) and fuel line (1) from the fuel tank (**Figure 16-13, Page 16-18**).
 10. Loosen the straps (13 and 18) by removing the screws (12) from the speed nuts (11).
 11. Lift the fuel tank out of the vehicle.

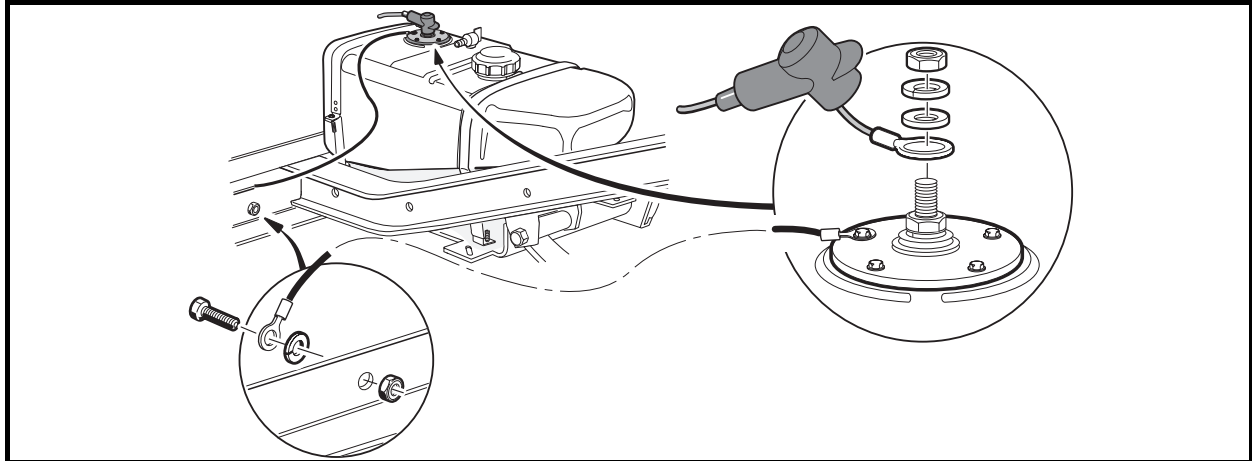

Figure 16-16 Fuel Level Sending Unit

FUEL TANK DISPOSAL

1. Remove the cap from the tank and thoroughly rinse it with water. The cap may be discarded or kept as a spare.
2. In a well-ventilated area, flush the fuel tank with water to remove any remaining fuel.
3. In a well-ventilated area, set the tank upside down so that the water can drain out of it. To make sure that the tank dries completely, allow the tank to sit for 24 hours. **See following CAUTION.**

▲ CAUTION

- **Dispose of wastewater and fuel tank in accordance with local, state, and federal laws and ordinances.**

FUEL TANK STORAGE

1. Remove the cap from the tank and thoroughly rinse it with water.
2. In a well-ventilated area, flush the fuel tank with water to remove any remaining fuel.
3. In a well-ventilated area, set the tank upside down so that the water can drain out of it. To make sure that the tank dries completely, allow the tank to sit for 24 hours.
4. Store the tank upside down, with the cap installed, in a well-ventilated area.

FUEL TANK INSTALLATION

1. With the retaining straps correctly positioned, install the fuel tank in the vehicle.
2. Secure the tank with the retaining straps (18) (**Figure 16-13, Page 16-18**).
 - 2.1. Position the straps in the indentions on the tank.
 - 2.2. Install the screws (12) into the speed nuts (11). Tighten screws and nuts to 25 in-lb (2.8 N·m).
3. Install the rear body on the vehicle if removed. **See Rear Body Installation, Section 4, Page 4-15.**
4. Install seat back support if removed. **See Seat Back Support Bracket Installation, Section 4, Page 4-12.**
5. Connect the vent tube (6) to the fuel tank vent (**Figure 16-13, Page 16-18**).

6. Connect the fuel line (1) to the fuel tank shut-off valve (15). Use a new clamp (**Figure 16-13, Page 16-18**).
7. Connect the black wire from the fuel gauge to one of the fuel level sending unit screws. Connect the orange wire to the center stud and install the flat washer, lock washer, and nut. Tighten to 18 in-lb (2.0 N·m).
8. Slide the rubber boot over the stud (**Figure 16-16, Page 16-23**).
9. Add fuel to the tank.
10. Connect battery cables, positive (+) cable first, and tighten hardware to 144 in-lb (16 N·m). **See Figure 1-1, Page 1-3.** Coat terminals with Battery Terminal Protector Spray (CCI P/N 1014305) to minimize corrosion
11. Check to be sure the fuel shut-off valve on top of the fuel tank is in the open (ON) position (**Figure 16-18, Page 16-25 or Figure 16-19, Page 16-25**).
12. **XRT 800/810:** Place the Forward/Reverse handle in the NEUTRAL position and chock the wheels. **See following DANGER.**
13. **XRT 850:** Place the Forward/Reverse handle in the NEUTRAL position, chock the wheels, and the neutral lockout switch in the MAINTENANCE position. **See following DANGER.**
14. Turn the key switch to the START position and start the engine. **See following DANGER.**

⚠ DANGER

- **Do not operate gasoline vehicle in an enclosed area without proper ventilation. The engine produces carbon monoxide, which is an odorless, deadly poison.**
- **After installing the fuel tank and adding fuel, carefully check all fuel lines and connections for leaks. Repair any fuel leaks before operating the vehicle.**

15. Allow the engine to run for a few minutes to ensure that the fuel lines are full of fuel.
16. Inspect each fuel line for leaks.
 - 16.1. Check all of the fuel line clamps at the carburetor, fuel filters, fuel pump, and fuel tank for leaks.
 - 16.2. Inspect each fuel line to ensure that the lines are not cracked, cut, or worn.

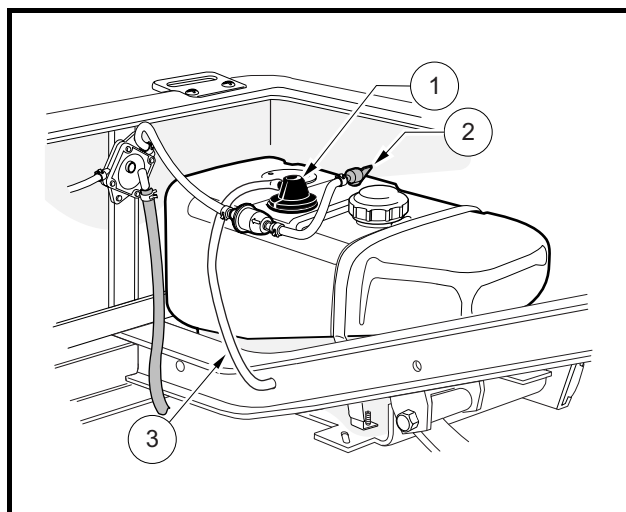

Figure 16-17 Fuel Tank

1. Vent 2. Fuel Shut-off Valve 3. Vent Tube

FUEL LINES

See General Warning on page 1-1.

The fuel lines must be properly routed, and all hose clamps must be tight. The fuel lines should be kept clean. See following WARNING.

⚠ WARNING

- Make sure fuel lines are the right length and are properly routed. Failure to heed this warning could result in damage to fuel lines and fire.

Fuel line no. 1 runs directly from the fuel tank to the primary fuel filter (17). The primary fuel filter (17) has an arrow indicating fuel flow direction (**Figure 16-13, Page 16-18**).

Fuel line no. 2 runs directly from the primary fuel filter to the fuel inlet of the fuel pump.

Fuel line no. 3 runs directly from the fuel outlet of the fuel pump to the secondary fuel filter (**Figure 16-13, Page 16-18**). The secondary fuel filter has an arrow indicating fuel flow direction and is identical to the primary fuel filter.

Fuel line no. 4 runs from the outlet of the secondary fuel filter to the carburetor (**Figure 16-13, Page 16-18**).

Small spring steel band clamps are used on all hose connections except at the carburetor. A screw band clamp (16) should be used at the carburetor (**Figure 16-13, Page 16-18**).

FUEL SHUT-OFF VALVE

See General Warning on page 1-1.

The fuel shut-off valve is located on top of the fuel tank (**Figure 16-18, Page 16-25 or Figure 16-19, Page 16-25**). The fuel shut-off valve should always be turned to the closed (OFF) position during vehicle storage, towing or trailering. Unless the engine will be run as part of a procedure, the fuel shut-off valve should also be closed (OFF) before performing maintenance or service procedures.

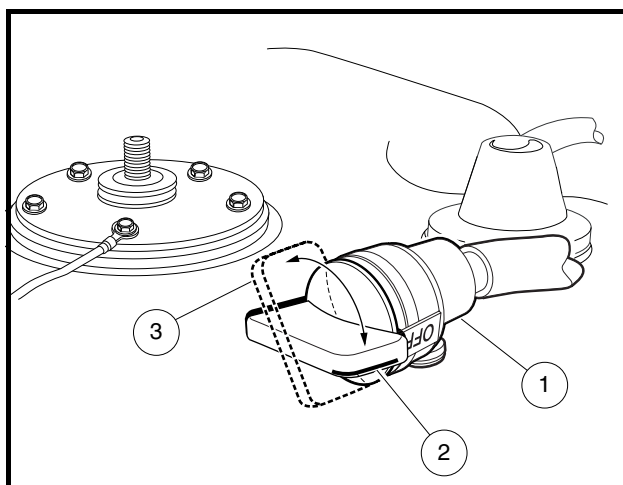

**Figure 16-18 Fuel Shut-off Valve –
49-State Fuel Tank Shown**

1. Fuel Shut-off Valve 2. Closed (OFF) 3. Open (ON)
NOTE: When selecting valve position, ensure that it is fully opened or fully closed.

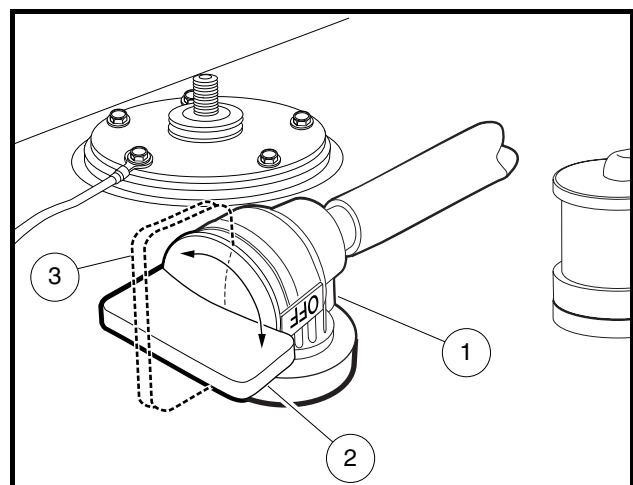

**Figure 16-19 Fuel Shut-off Valve –
California Fuel Tank Shown**

1. Fuel Shut-off Valve 2. Closed (OFF) 3. Open (ON)
NOTE: When selecting valve position, ensure that it is fully opened or fully closed.

FUELING INSTRUCTIONS

See General Warning on page 1-1.

DANGER

- Turn the key switch to the OFF position before fueling.
- Do not pour fuel into the fuel tank when the engine is hot or while it is running.
- To avoid electric arc caused by static electricity, the fuel storage/pumping device must be grounded. If the pump is not grounded, the vehicle must be grounded to the pump before and during the fueling operation.
- If the vehicle has an all-weather enclosure installed, be sure the fuel tank is properly vented as shown (Figure 16-17, Page 16-24).
- To avoid the possibility of fire, clean up any spilled fuel before operating the vehicle.

CAUTION

- To allow for expansion, do not fill higher than 2.54 cm (one inch) from the top of the fuel tank. Avoid spilling fuel.

NOTE: Whenever possible, avoid using oxygenated fuels and fuels that are blended with alcohol. Vehicles to be stored for extended periods should be prepared for storage as instructed. **See Preparing the Gasoline Vehicle for Extended Storage on page 3-2.**

1. Turn the key switch to the OFF position.
2. Lift and remove seat bottom.
3. The fuel tank is located on passenger side of vehicle. Remove fuel cap and fill the fuel tank with fresh unleaded gasoline only. **See preceding CAUTION.**
4. Replace fuel cap on tank. Ensure cap is tightened securely.
5. Replace seat bottom.

SECTION 17 – EXHAUST SYSTEM: GASOLINE VEHICLES

⚠ DANGER

- See General Warning on page 1-1.

⚠ WARNING

- See General Warning on page 1-1.

MUFFLER

MUFFLER REMOVAL

1. Disconnect the battery cables as instructed. **See WARNING “To avoid unintentionally starting...” in General Warning on page 1-2.**
2. Disconnect the spark plug wire from the spark plug. **See WARNING “To avoid unintentionally starting...” in General Warning on page 1-2.**
3. Remove the muffler clamp (6) from the muffler (1) and clamp bracket (2) (**Figure 17-1, Page 17-2**).
4. Remove the hex-head cap screw (7), lock washer (8), and flat washer (9) from mounting bracket. Retain the governor cable bracket (13).
5. Remove the hex nuts (10) and lock washers (11) from the manifold.
6. Remove the muffler (1) from the vehicle.

MUFFLER INSTALLATION

NOTE: Any time the muffler is removed from the vehicle, install a new muffler clamp (6) (CCI P/N 1017689) and muffler gasket (12) FE290 (CCI P/N 1015330) (**Figure 17-1, Page 17-2**).

1. Loosely secure muffler (1) to muffler bracket (2) with clamp (6).
2. Place a new gasket (12) on the cylinder block exhaust stud bolts.
3. Attach muffler manifold with lock washers (11) and hex nuts (10) and finger tighten.
4. Loosely secure muffler (1), mounting bracket, and governor cable bracket (13) using hex-head cap screw (7), lock washer (8), and flat washer (9).
5. Tighten manifold hex nuts (10) to 11 ft-lb (14.9 N·m).
6. Tighten the hex cap screw (7) to 14 ft-lb (18.9 N·m).
7. Tighten the muffler clamp (6) to 40 in-lb (4.5 N·m).

NOTE: Removing and installing the governor cable bracket may change the RPM setting. **See Engine RPM Adjustment on page 16-12.**

8. Connect the spark plug wire.

9. Connect battery cables, positive (+) cable first, and tighten hardware to 144 in-lb (16 N·m). **See Figure 1-1, Page 1-3.** Coat terminals with Battery Terminal Protector Spray (CCI P/N 1014305) to minimize corrosion
10. **XRT 800/810:** Place the Forward/Reverse handle in the NEUTRAL position and chock the wheels.
11. **XRT 850:** Place the Forward/Reverse handle in the NEUTRAL position, chock the wheels, and the neutral lockout switch in the MAINTENANCE position.
12. Start the engine and check for exhaust leaks and proper engine operation. **See following DANGER.**

⚠ DANGER

- Do not operate gasoline vehicle in an enclosed area without proper ventilation. The engine produces carbon monoxide, which is an odorless, deadly poison.

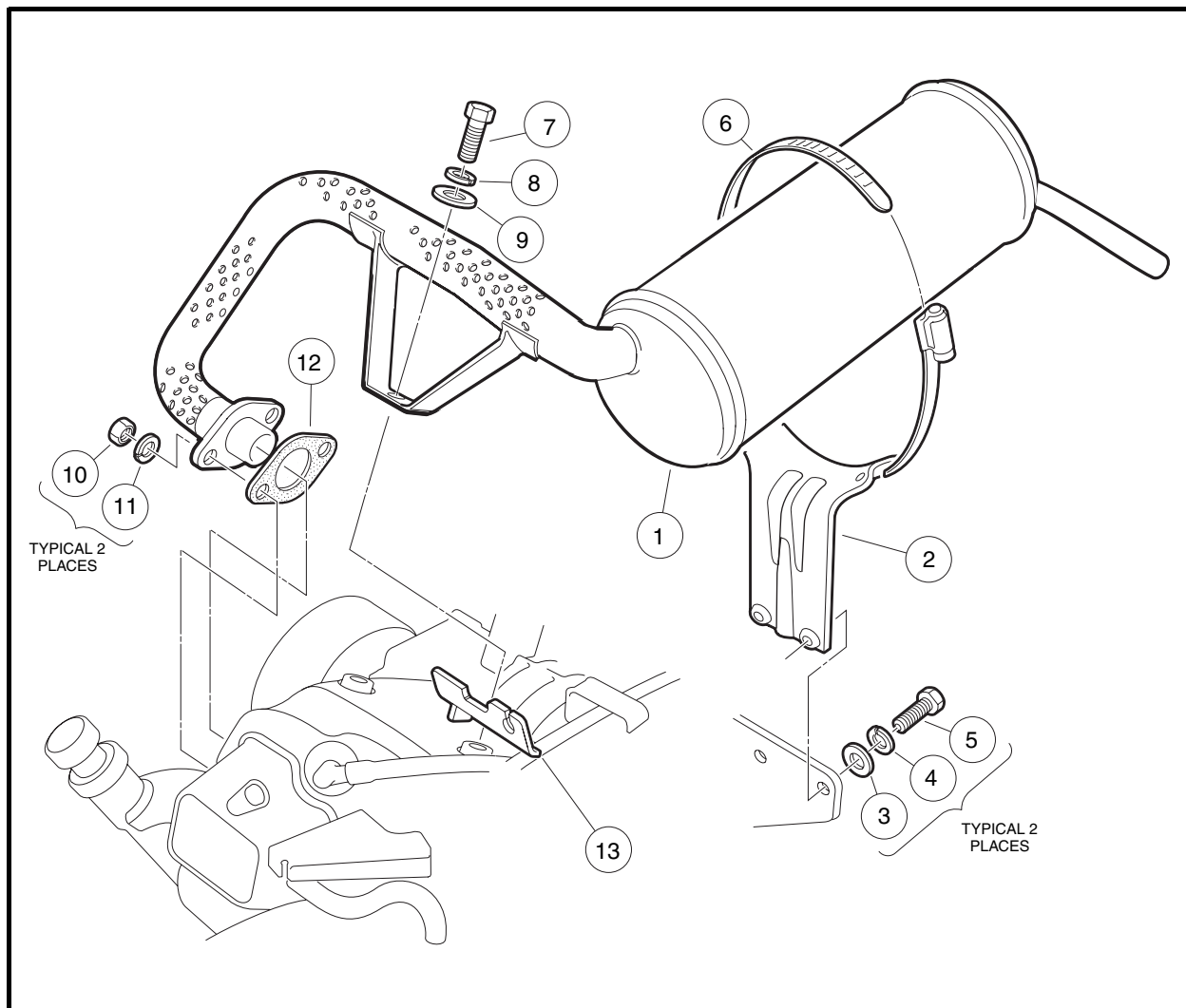

Figure 17-1 Exhaust System

SECTION 18 – UNITIZED TRANSAXLE: 800/810 GASOLINE VEHICLES

⚠ DANGER

- See General Warning on page 1-1.

⚠ WARNING

- See General Warning on page 1-1.

GENERAL INFORMATION

Shifter Lever

A shifter lever, connected to a shifter arm, is used to change the gears to one of three shift positions: FORWARD (F), NEUTRAL (N), or REVERSE (R) (**Figure 18-1, Page 18-1**). Bring the vehicle to a complete stop before changing FORWARD or REVERSE direction.

Governor System

The governor system regulates vehicle ground speed. It is mounted inside the unitized transaxle and is driven by transaxle gears. If any of the governor linkages are removed in order to service other components, readjustment of the governor linkage is required. **See Governor Cable Installation and Adjustment on page 16-9.**

Unitized Transaxle Service

The unitized transaxle is extremely durable and should require very little service under normal operating conditions. The only service required is to maintain proper lubricant level. **See Periodic Lubrication Schedules, Section 10, Page 10-4.**

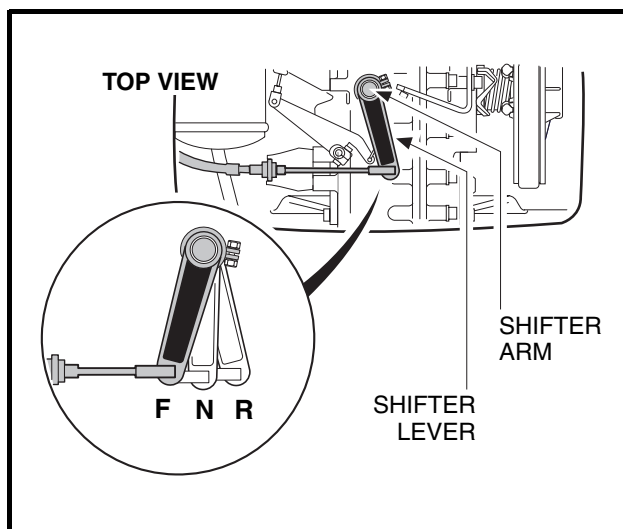

Figure 18-1 Shifter Positions

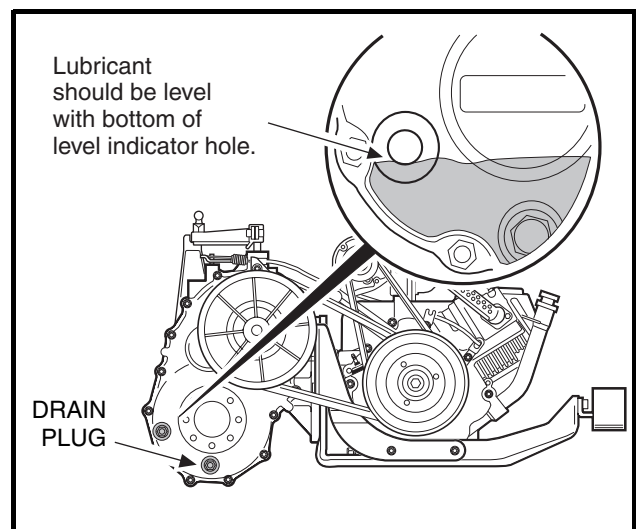

Figure 18-2 Lubricant Level

Tools Required For This Section

Hydraulic floor jack (or chain hoist)	Torque wrench, 3/8-in. drive	1/2-in. combination wrench
Jack stands (2) (one ton capacity)	3/8-in. socket, 3/8-in. drive	9/16-in. combination wrench
Standard slip joint pliers	7/16-in. socket, 3/8-in. drive	Small flat blade screwdriver
External snap ring pliers (.047-in. tip)	1/2-in. socket, 3/8-in. drive	Medium flat blade screwdrivers (2)
90° Internal snap ring pliers (.090-in. tip)	9/16-in. socket, 3/8-in. drive	No. 2 phillips-head screwdriver
16-in. rolling head prybar	5/8-in. socket, 3/8-in. drive	1/4-in. nut driver
Plastic or rubber mallet	Axle seal tool (CCI P/N 1014162)	5/16-in. nut driver
Ratchet wrench, 3/8-in. drive	7/16-in. combination wrench	

LUBRICATION

There are two oil port plugs located on the right (driven clutch) side of the unitized transaxle (**Figure 18-2, Page 18-1**). When the vehicle is on a level surface, use the upper plug as a lubricant level indicator. Lubricant level should be even with the bottom of level indicator hole. Use the lower plug for draining. When draining lubricant, remove both plugs to allow the lubricant to drain faster. Clean and reinstall the drain plug and gasket before filling the transaxle with new lubricant. Use a funnel when filling the transaxle through the lubricant level indicator hole. Fill with 27 oz. (0.8 liter) 80-90 WT. API class GL or 80-90 WT. AGMA class 5 EP gear lubricant (or until lubricant begins to run out of the level indicator hole). Tighten the plug to 20 ft-lb (27.1 N·m).

AXLE SHAFT

See General Warning on page 1-1.

Removal of the unitized transaxle is not required for servicing or replacing axle shafts, axle bearings, or axle shaft oil seals. If the unitized transaxle is to be removed from the vehicle, do not remove the wheels, axle shafts, or axle tubes first. Instructions for removing the unitized transaxle from the vehicle begin on page 18-6.

AXLE SHAFT AND OIL SEAL REMOVAL

1. Turn the key switch to the OFF position and remove the key, place the Forward/Reverse handle in the NEUTRAL position, and chock the wheels.
2. Disconnect the battery cables as instructed. **See WARNING “To avoid unintentionally starting...” in General Warning on page 1-2.**
3. Loosen the lug nuts on the wheel to be removed.
4. Place chocks at the front wheels and lift the rear of the vehicle with a floor jack. Then place jack stands under the axle tubes to support the vehicle. **See WARNING “Lift only one end of the vehicle...” in General Warning, Section 1, Page 1-1.**
5. Remove the rear wheel and brake drum.
6. Use 90° internal snap ring pliers (0.090-in. tip) to remove internal retaining ring (1) from axle tube (**Figure 18-3, Page 18-3**).
7. Carefully pull the axle shaft (2) straight out of the axle tube (**Figure 18-3, Page 18-3**).

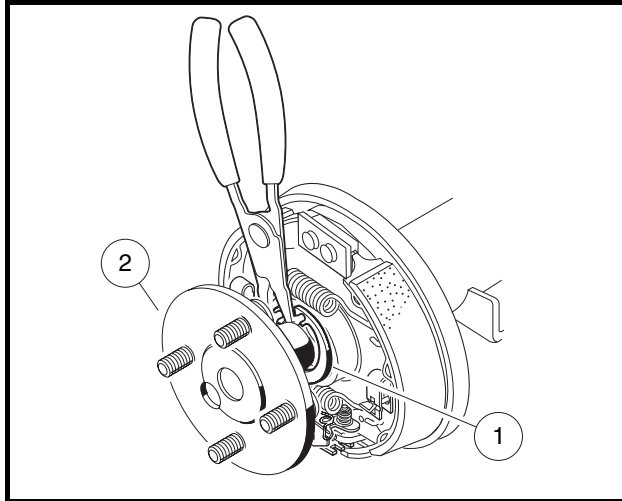

Figure 18-3 Retaining Ring

8. Position a 16-inch (40 cm) rolling head prybar (Figure 18-4, Page 18-3) under the inside lip of the seal and pull the oil seal out (Figure 18-5, Page 18-3). See following CAUTION.

⚠ CAUTION

- Do not scar or damage the inside surfaces of the tube when removing the oil seal. A damaged tube might have to be replaced.

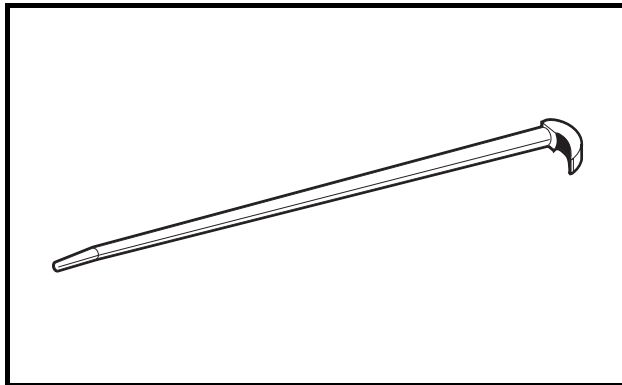

Figure 18-4 Rolling Head Prybar

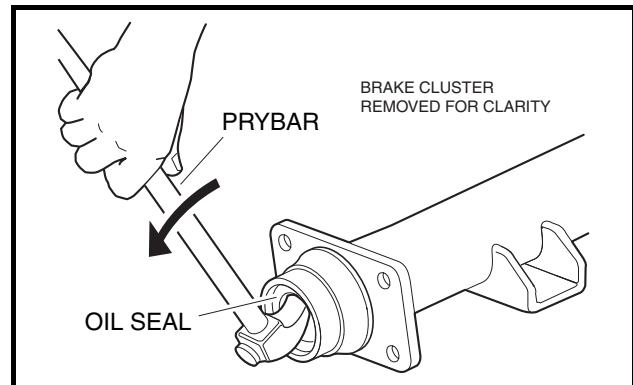

Figure 18-5 Seal Lip

9. Inspect the axle shaft assembly to be sure the bearing (71) and collar (73) have not slipped and are still seated against the shoulder on the axle shaft (Figure 18-6, Page 18-4).
10. Inspect the bearing. If the bearing is damaged or worn, replace it.

AXLE BEARING

Axle Bearing Removal

1. Use external retaining ring pliers (0.047-inch tip) to remove the retaining ring (74). Place a bearing puller wedge attachment (CCI P/N 1012812) on the axle shaft between the wheel mounting flange and the bearing (Figure 18-6, Page 18-4). See also Figure 18-7, Page 18-6. See following CAUTION.

CAUTION

- Do not tighten the bearing puller wedge attachment against the axle shaft. This could damage the axle shaft when pressing the bearing and collar off.

2. Press the bearing (71) and collar (73) off together (Figure 18-6, Page 18-4). See also Figure 18-7, Page 18-6. See following NOTE.

NOTE: It may be necessary to heat the collar to remove it.

Do not remove the large axle retaining ring (70) from the axle (Figure 18-6, Page 18-4). Since the inner diameter of the retaining ring (70) is smaller than the outer diameter of the bearing (71), the ring must be in place on the axle before a new bearing and collar are pressed on.

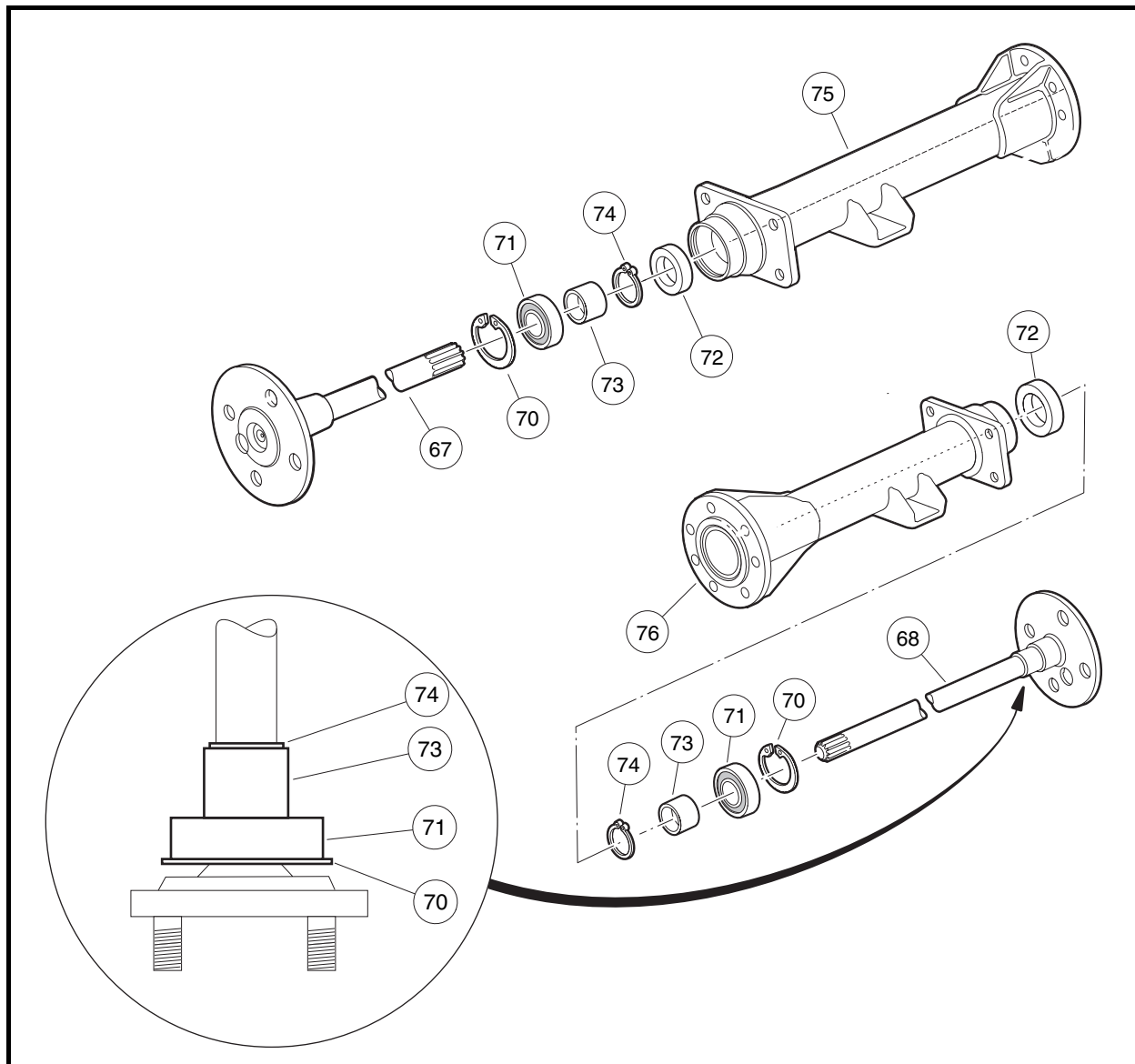

Figure 18-6 Differential Gear Case/Axle Tubes

Axle Bearing Installation

1. Ensure that the retaining ring (70) is loosely placed on the axle shaft. **See preceding NOTE.**
2. Install a new axle bearing (71) on axle (67 or 68). Push bearing onto axle until bearing is flush against axle shoulder (**Figure 18-6, Page 18-4**).
3. Apply two drops of Loctite 271[®] to inside of the collar. **See following CAUTION.**

⚠ CAUTION

- Apply Loctite 271 to the inside of the collar only, not to the shaft, so that the Loctite will be pushed away from the bearing as the collar and bearing are pressed on. If Loctite gets on or in the bearing, the bearing must be replaced.
 - The collar should be removed no more than two times. If a collar is removed a third time, the shaft and collar will not fit properly.
4. Place a new sealed bearing (71) on shaft (67 or 68) (**Figure 18-6, Page 18-4**).
 5. Install collar (73) onto axle shaft. Place axle assembly on bearing puller wedge attachment and press collar onto axle.
 6. Place the bearing puller wedge attachment against collar and press both bearing and collar onto shaft. **See following CAUTION.**

⚠ CAUTION

- If the bearing was removed from the shaft, replace it with a new one.
 - Do not tighten the bearing puller wedge attachment against the axle shaft. This could damage the axle shaft when the bearing and collar are pressed on.
7. Use external snap ring pliers (0.047-in. tip) to install collar retaining ring (74) (**Figure 18-6, Page 18-4**).

AXLE SHAFT INSTALLATION

1. Clean bearing and seal seats in axle tube (75 or 76) (**Figure 18-6, Page 18-4**).
2. Place a new oil seal (72) in axle tube with seal lip facing inside of the axle tube (**Figure 18-6, Page 18-4**). Use an axle seal tool (CCI P/N 1012811) to press it in until it seats firmly in position (**Figure 18-8, Page 18-6**). **See following NOTE.**

NOTE: The new seal can be installed by tapping the axle seal tool with a mallet.

⚠ CAUTION

- Clean any residual oil from the exposed end of the axle shaft and from the oil seal area prior to installing the axle shaft.
3. Clean the axle shaft and splines and then insert the shaft, splined end first, through the seal and into the axle tube. Be careful not to damage the seal. Then advance the shaft through the inner bearing and rotate it to align the shaft splines with the splined bore of the differential side gear. Continue advancing the shaft until the bearing seats against the axle tube shoulder.
 4. Install the bearing retaining ring (70) in the axle tube (**Figure 18-6, Page 18-4**). **See also Figure 18-3, Page 18-3.**

- Place a 1/4 to 3/8-inch (6-10 mm) diameter rod against the retaining ring and tap lightly at four to five locations to ensure it is properly seated. **See following WARNING.**

⚠ WARNING

- Be sure bearing retaining ring is properly seated in its groove. If ring is not properly installed, the axle assembly will separate from the transaxle and damage the axle assembly and other components. Loss of vehicle control could result in severe personal injury or death.

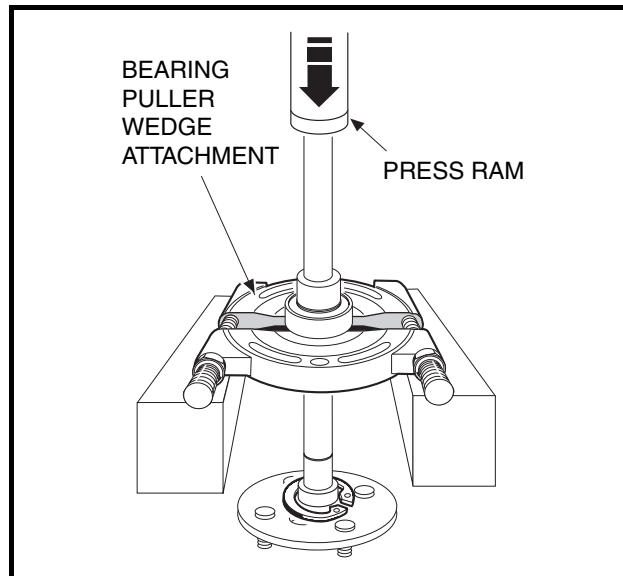

Figure 18-7 Bearing and Collar

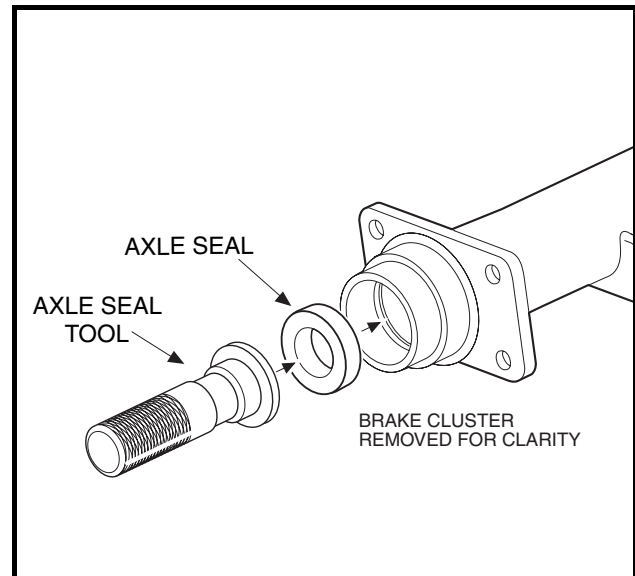

Figure 18-8 Axle Seal Tool

UNITIZED TRANSAXLE REMOVAL

See General Warning on page 1-1.

- Turn the key switch to the OFF position and remove the key, and place the Forward/Reverse handle in the NEUTRAL position.
- Disconnect the battery cables as instructed. **See WARNING “To avoid unintentionally starting...” in General Warning on page 1-2.**
- Close the fuel shut-off valve on fuel tank (**Figure 16-18, Page 16-25** or **Figure 16-19, Page 16-25**).
- Detach all wires, hoses, etc. connecting the powertrain to the vehicle.
 - Disconnect the carburetor vent tube from the carburetor (**Figure 18-9, Page 18-7**).
 - Disconnect the air intake hose from the carburetor (**Figure 18-10, Page 18-7**).

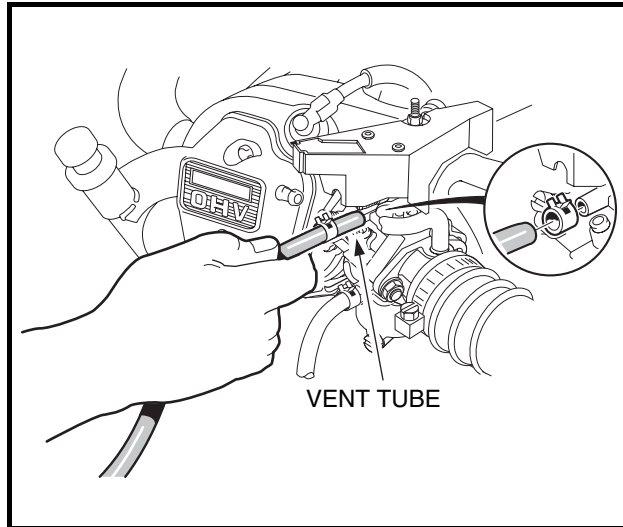

Figure 18-9 Fuel Vent Tube

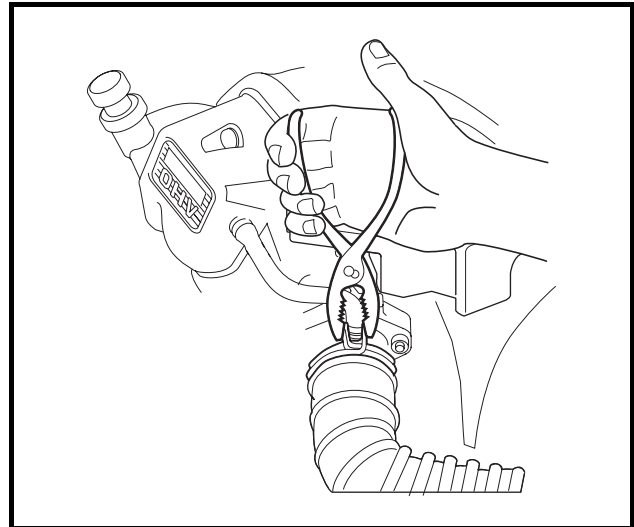

Figure 18-10 Air Intake Hose

- 4.3. Disconnect impulse line from fuel pump (**Figure 18-11, Page 18-7**).
- 4.4. Loosen the hose clamp and then disconnect the fuel line from the carburetor. To prevent spilling fuel, the disconnected end of the line can be plugged with a 1/4-inch bolt (**Figure 18-12, Page 18-7**).

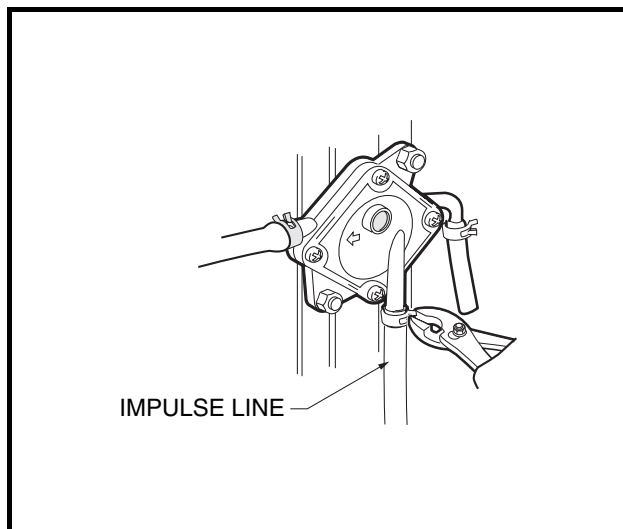

Figure 18-11 Impulse Line

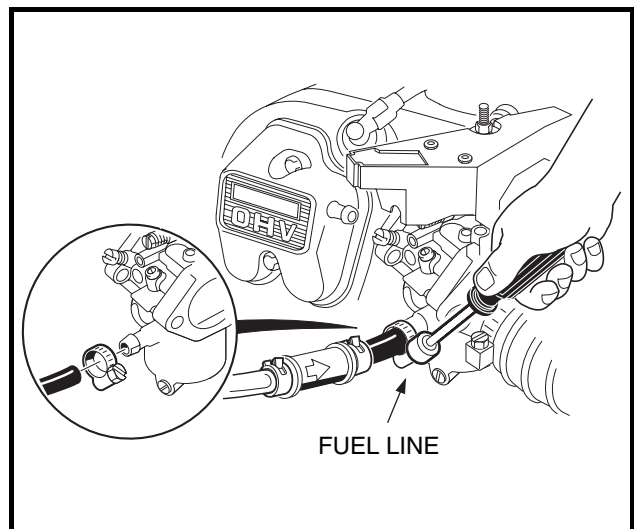

Figure 18-12 Fuel Line

- 4.5. Remove the cover from the electrical component box. Then loosen the hardware securing the accelerator cable to the box. Disconnect the cable from the actuator cam and remove it from the box (**Figure 18-13, Page 18-8**).
- 4.6. Remove retaining nut and disconnect the engine ground wire from the oil filler tube mounting bracket (**Figure 18-14, Page 18-8**).

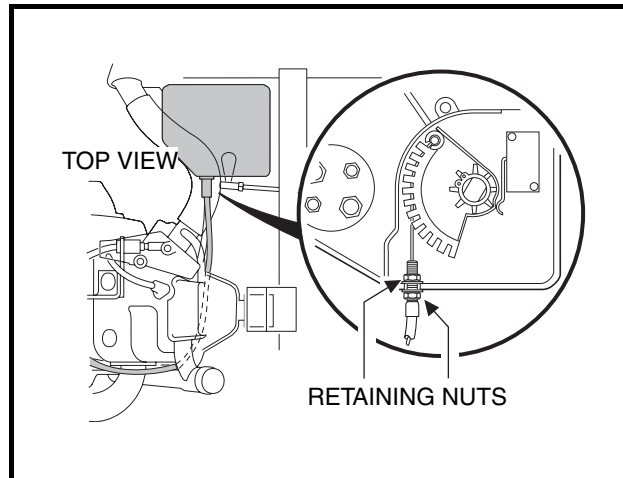

Figure 18-13 Throttle Cable

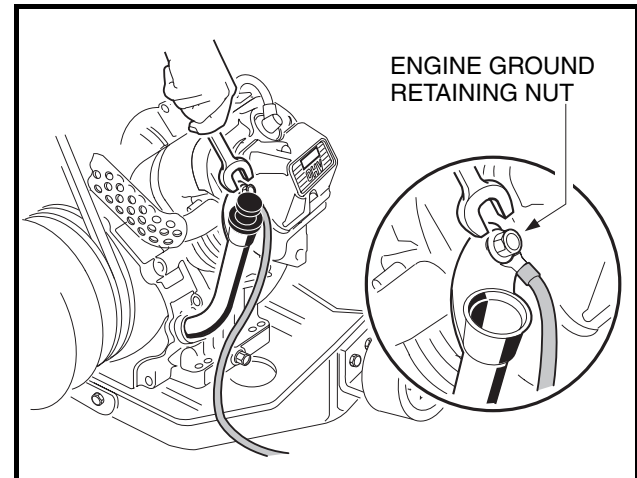

Figure 18-14 Engine Ground Wire

- 4.7. Loosen nuts securing shifter cable to shifter cable mounting bracket. Then disconnect the shifter cable rod end from the shifter arm on the unitized transaxle and remove the cable from the cable mounting bracket (**Figure 18-15, Page 18-8**).
- 4.8. Mark for identification and then disconnect the 6-gauge white wire (F2 post), 6-gauge black ground wire (A2 post), and 16-gauge yellow wire (DF post) from starter/generator (**Figure 18-16, Page 18-8**).

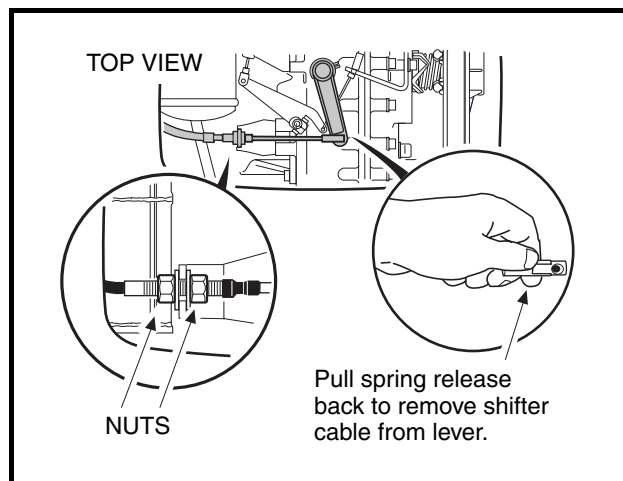

Figure 18-15 Shifter Cable

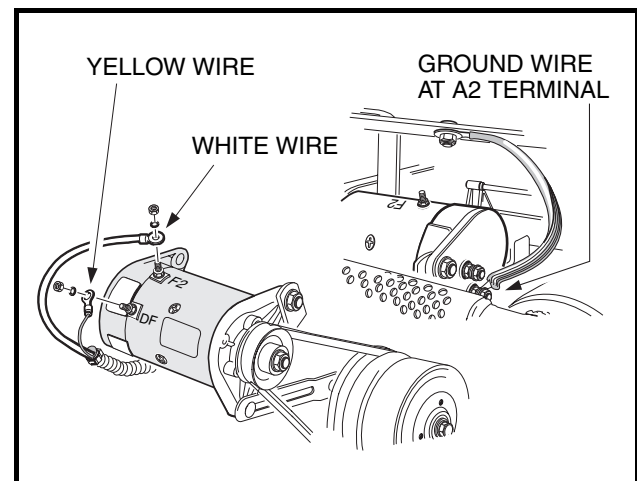

Figure 18-16 Generator Wires

- 4.9. Disconnect the engine oil level sensor wire (18-gauge yellow) at the connector just to the rear of the starter/generator) (**Figure 18-17, Page 18-9**).
- 4.10. Disconnect the engine kill switch wire (18-gauge white/black) from the bullet connector at the lower right front of the engine (**Figure 18-18, Page 18-9**).
- 4.11. Cut away the wire ties securing the engine kill wire at the lower right front of the engine (below the exhaust header), the wire harness at the governor cable bracket, and the wire harness to the plate beneath the muffler.

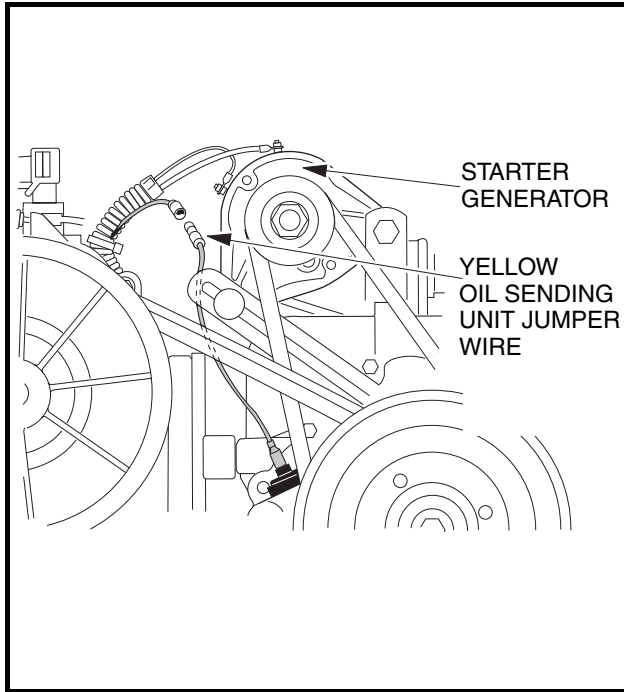

Figure 18-17 Oil Level Sensor Jumper Wire

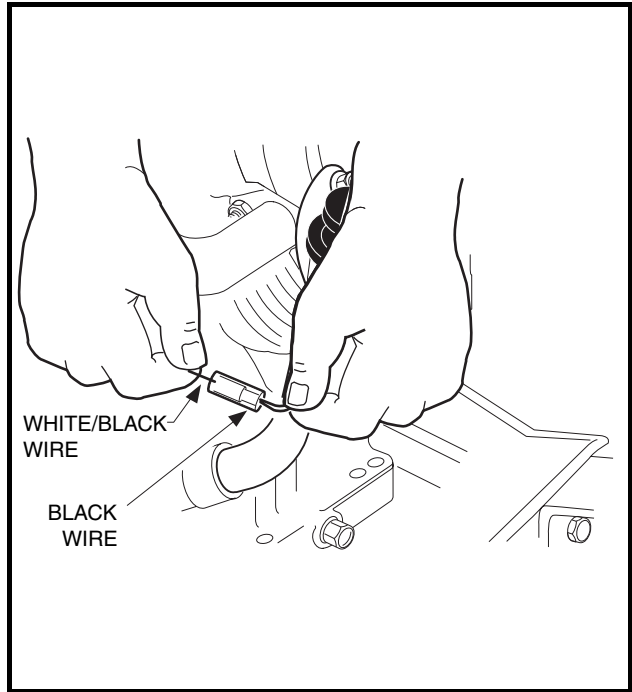

Figure 18-18 Ignition Kill Wire

5. Disconnect the brake cables.

5.1. Remove bow tie pins (1), brake cable clevis pins (2), and E-clips (3) (Figure 18-19, Page 18-9).

5.2. Remove the cable from the cable support bracket (Figure 18-19, Page 18-9).

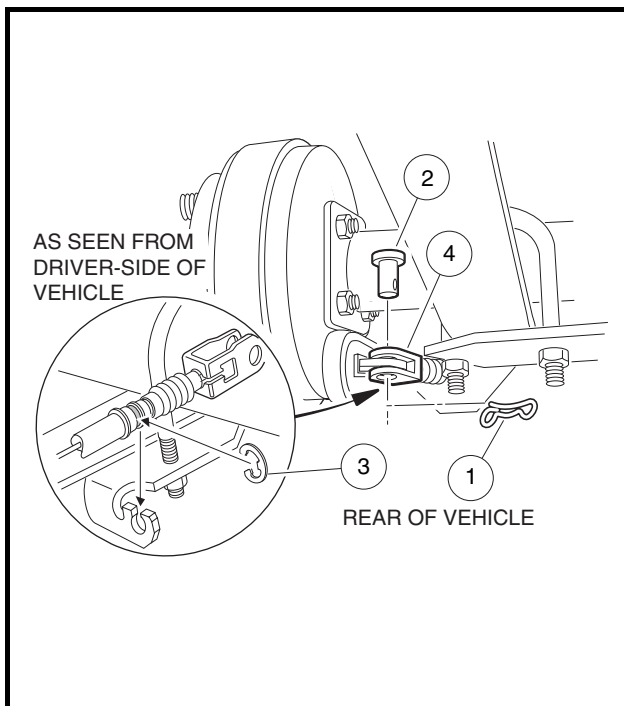

Figure 18-19 Brake Cable

6. Remove the lower shock mounting hardware from both rear shocks (**Figure 18-20, Page 18-10**).
7. Position a floor jack under the vehicle frame crossmember or trailer hitch mount (**Figure 18-21, Page 18-10**).

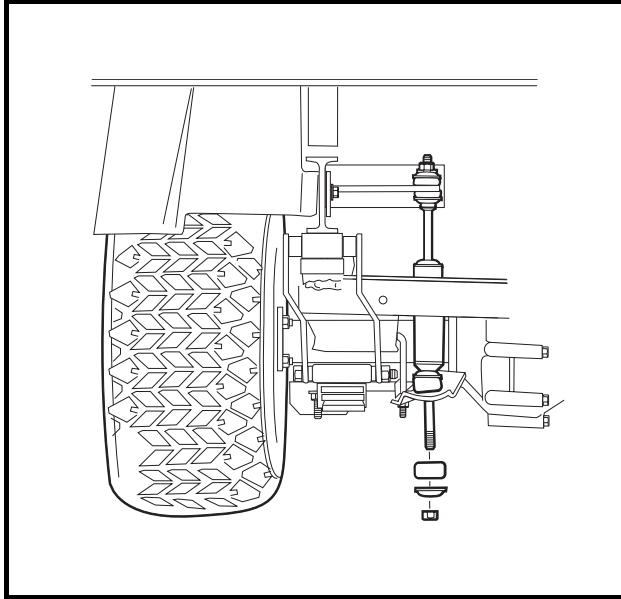

Figure 18-20 Shock Absorbers

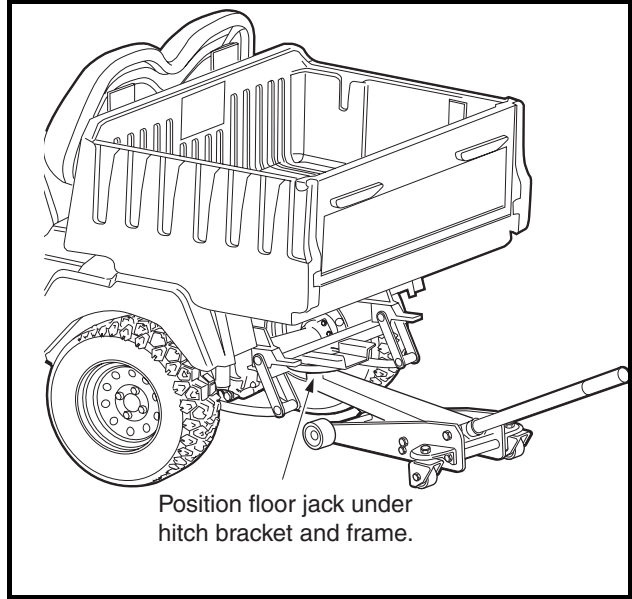

Figure 18-21 Floor Jack

8. Raise vehicle just enough to relieve tension from leaf springs, then remove the bolts securing the leaf springs to the shackles (**Figure 18-22, Page 18-10**).
9. Remove the bolts securing the leaf springs to their front mounts (**Figure 18-23, Page 18-10**).

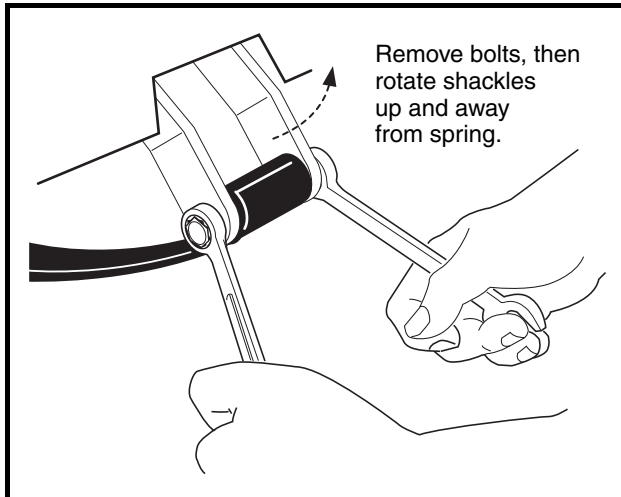

Figure 18-22 Rear Shackles

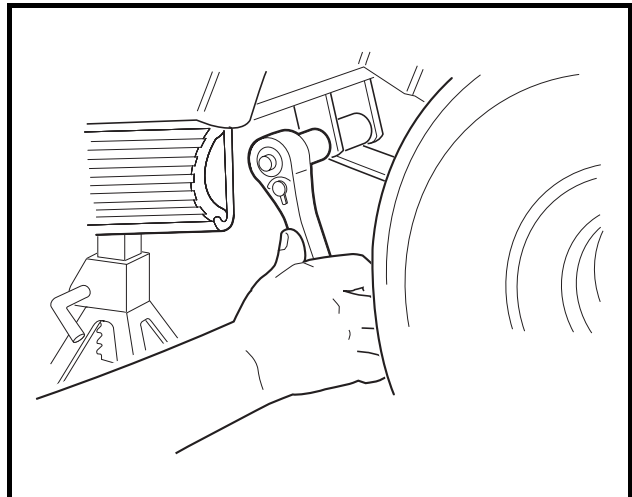

Figure 18-23 Spring Retainer Bolts

10. Continue raising vehicle until frame or trailer hitch is higher than the top of the unitized transmission (enough to allow transaxle and engine to be rolled under and out of vehicle) (**Figure 18-24, Page 18-11**).

11. Position jack stands, adjusted to support the vehicle at this height, under the frame crossmember between the leaf spring mounts and side stringers, just forward of each rear wheel. Lower the floor jack to allow the jack stands to support the vehicle (**Figure 18-25, Page 18-11**).

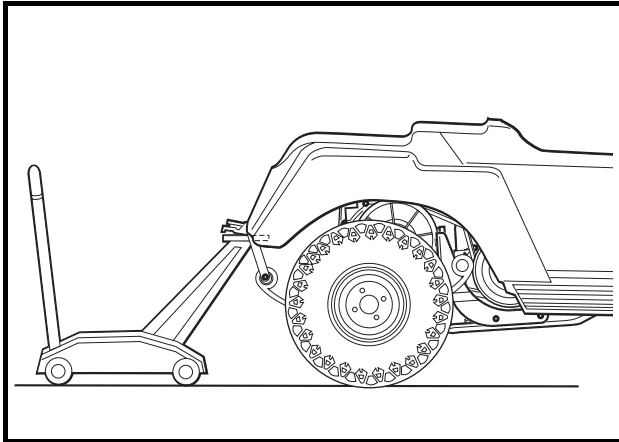

Figure 18-24 Raise Vehicle

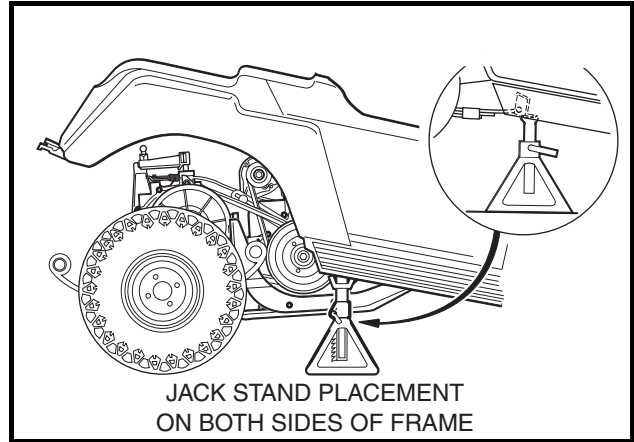

Figure 18-25 Position Jack Stands

12. Pull the floor jack from beneath the vehicle and move it away.
13. Carefully lift the snubber out of the snubber bracket in the vehicle frame and lower it to the floor (**Figure 18-26, Page 18-11**). The powertrain should be completely disconnected from the vehicle and resting on the floor.
14. Grasp the ends of the leaf springs at the rear of the vehicle and roll the powertrain out from under the vehicle (**Figure 18-27, Page 18-11**).

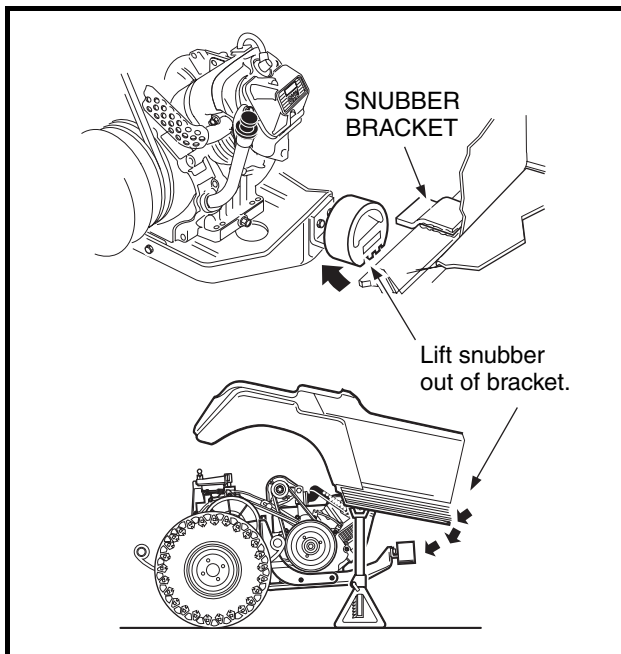

Figure 18-26 Snubber

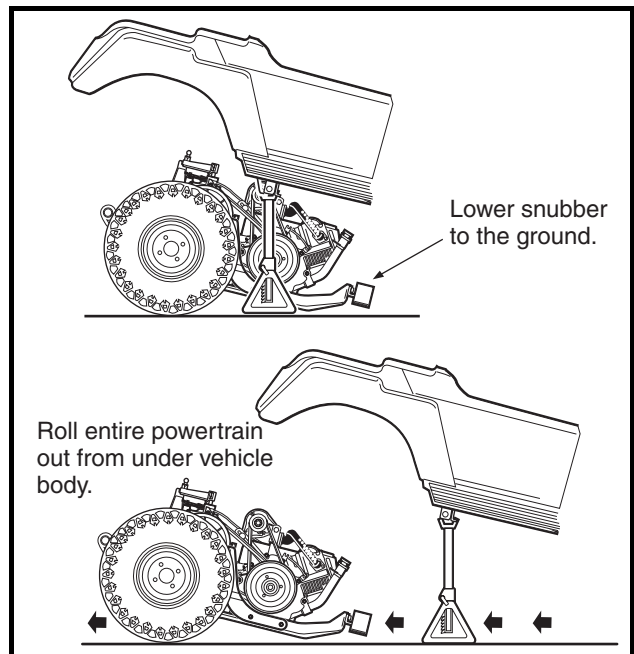

Figure 18-27 Remove Powertrain

15. Place blocks under the engine pan so they will completely support the engine and keep it **level to the floor** (**Figure 18-28, Page 18-12**). See following **NOTE**.

NOTE: Place the blocks so they will support the engine when the transaxle is detached and moved away from the engine.

16. Remove the drive belt.

- 16.1. Grasp belt midway between drive and driven clutch and pull up on belt to force the driven clutch sheaves apart. Roll the belt counterclockwise while pulling it off driven clutch (**Figure 18-29, Page 18-12**).

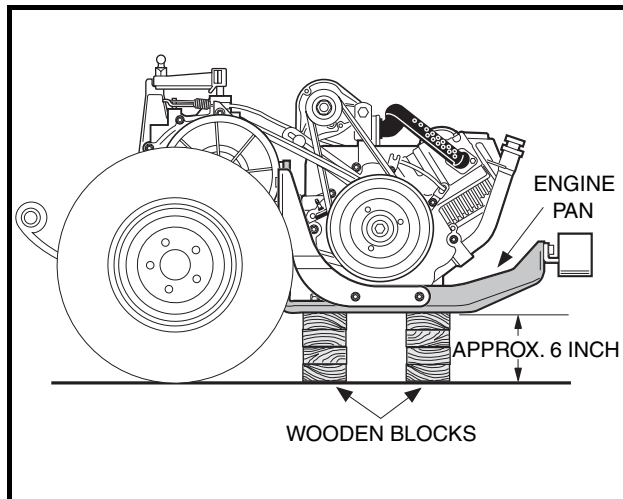

Figure 18-28 Position Powertrain

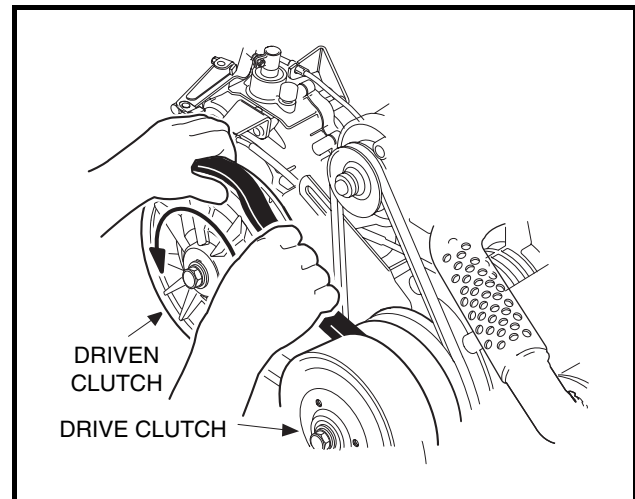

Figure 18-29 Remove Drive Belt

17. Remove the driven clutch retaining bolt and remove the driven clutch from the unitized transaxle (**Figure 18-30, Page 18-12**).

18. Loosen, but do not remove, the governor arm retaining bolt (1) (**Figure 18-31, Page 18-12**). Remove the governor arm from the shaft. Do not disconnect cables.

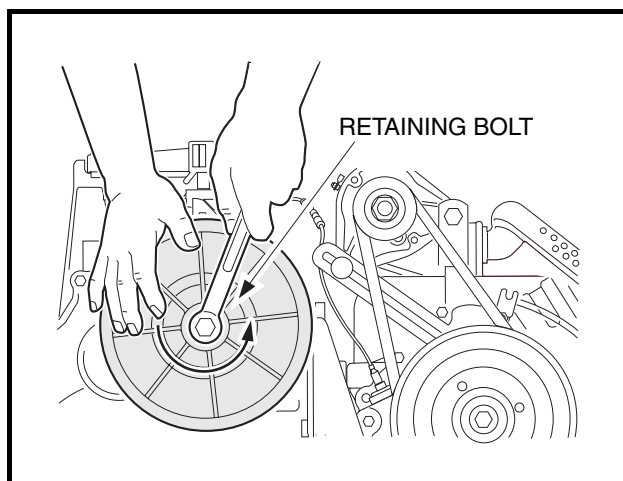

Figure 18-30 Driven Clutch

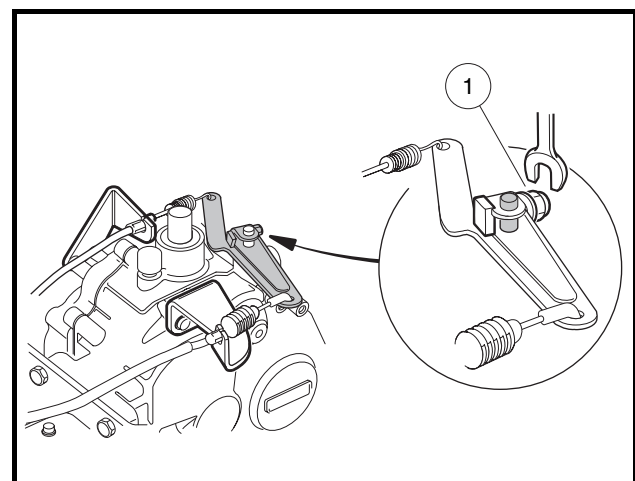

Figure 18-31 Governor Arm

19. Remove screws (1) securing the governor cable bracket to transaxle (**Figure 18-32, Page 18-13**).

20. Remove screws (1) securing the accelerator cable bracket to transaxle (**Figure 18-33, Page 18-13**).

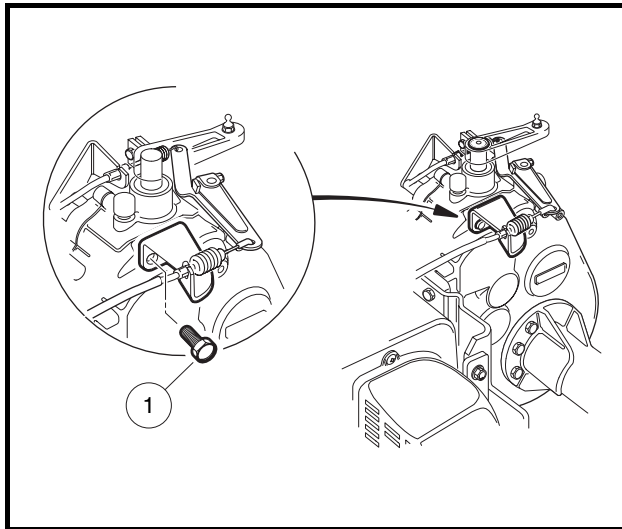

Figure 18-32 Governor Cable Bracket

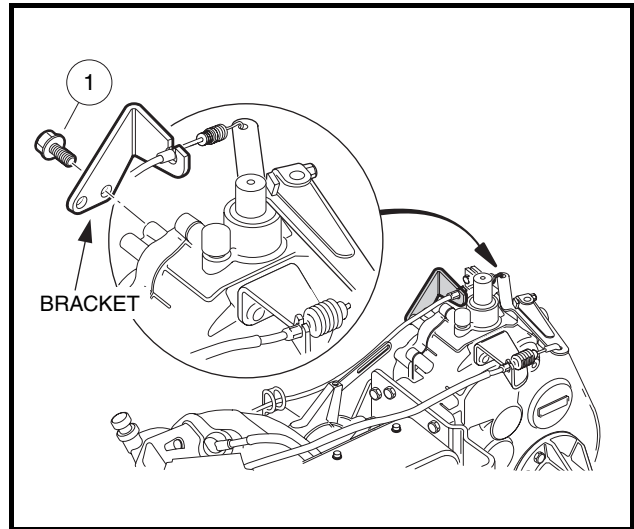

Figure 18-33 Accelerator Cable Bracket

21. Remove screws (2) securing the transmission shift cable bracket (1) to transaxle (**Figure 18-35, Page 18-13**). See following **NOTE**.

NOTE: The governor cable and the accelerator cable should remain attached to the governor arm.

22. Remove the six bolts mounting the unitized transaxle to the engine.
- 22.1. Remove four transaxle mounting bolts (one at each corner of the transaxle mounting plate) (**Figure 18-34, Page 18-13**).
- 22.2. Remove two middle transaxle mounting nuts from the engine block studs.
23. Remove leaf springs, wheels and brake assemblies from the transaxle.

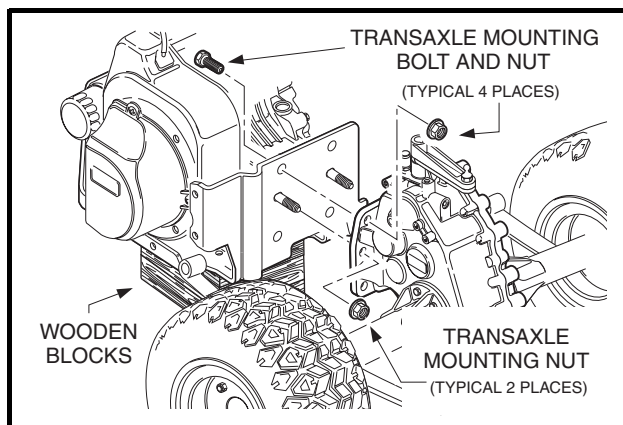

Figure 18-34 Transaxle Mounting

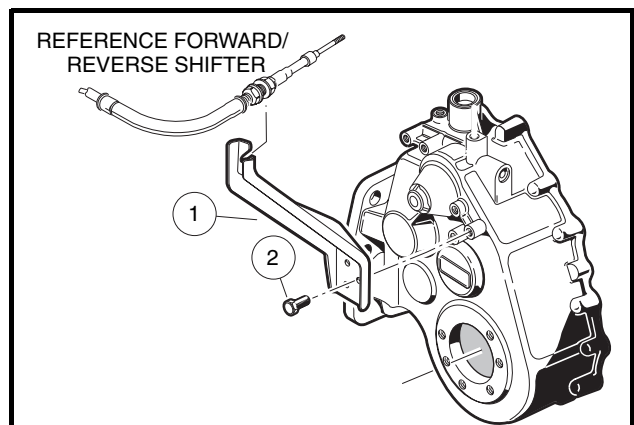

Figure 18-35 Gear Case and Cable Bracket

UNITIZED TRANSAXLE INSTALLATION

See General Warning on page 1-1.

1. Install the wheels. **See Wheel Installation, Section 8, Page 8-1.**
2. Install the leaf springs. **See Leaf Spring Installation – All Vehicles, Section 9, Page 9-4.**
3. Position the transaxle mounting plate on the two mounting studs at the rear of the engine, and then install the two mounting nuts finger tight (**Figure 18-36, Page 18-14**).
4. Install the remaining four mounting bolts and four nuts (one bolt and nut at each corner of the mounting plate) finger tight.
5. Tighten the four corner nuts (with bolts) to 30 ft-lb (40.7 N·m). Tighten the two center nuts (on the engine block studs) to 17 ft-lb (23.1 N·m) (**Figure 18-36, Page 18-14**).
6. Install the accelerator cable bracket on transaxle case. Tighten the mounting screws to 134 in-lb (15.1 N·m) (**Figure 18-33, Page 18-13**).

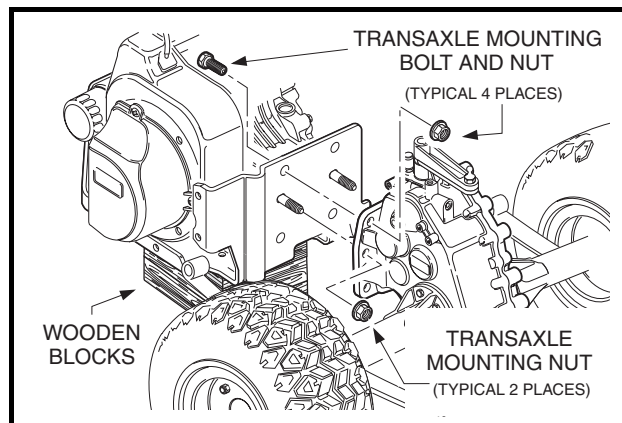

Figure 18-36 Transaxle Mounting

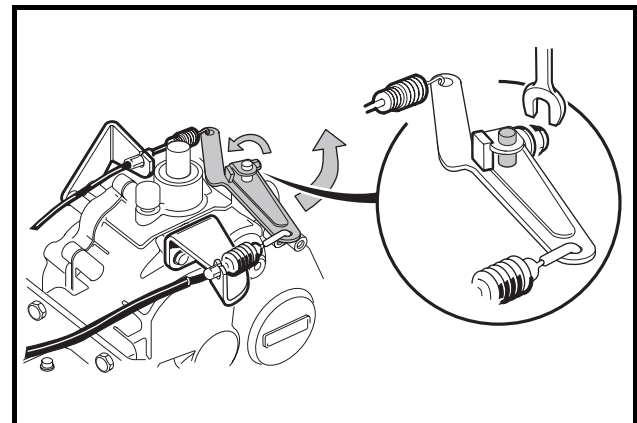

Figure 18-37 Governor Arm

7. Install the governor cable bracket on transaxle case. Tighten the mounting screws to 134 in-lb (15.1 N·m) (**Figure 18-32, Page 18-13**).
8. Install governor lever arm on governor shaft (**Figure 18-37, Page 18-14**).
 - 8.1. With the governor lever arm loose on the governor shaft, turn the governor arm shaft counterclockwise until it stops. Then pull the governor lever arm rearward until the carburetor throttle is in the "wide open throttle" (WOT) position (**Figure 18-37, Page 18-14**).
 - 8.2. While holding the arm and shaft in the fully counterclockwise position, tighten the governor arm lever nut to 35 in-lb (4.0 N·m) (**Figure 18-37, Page 18-14**).
9. Install the key onto the input shaft (**Figure 18-38, Page 18-15**).
10. Position the driven clutch on the transaxle input shaft and install the washer (yellow side facing out) and mounting bolt. Tighten the mounting bolt to 14 ft-lb (19.0 N·m) (**Figure 18-38, Page 18-15**).
11. Install the drive belt. **See Drive Belt Installation, Section 20, Page 20-3.**

12. Remove the blocks from under the engine and roll the powertrain into position under the vehicle. Then lift the front of the powertrain and place the snubber into the snubber bracket in the vehicle frame (Figure 18-39, Page 18-15).

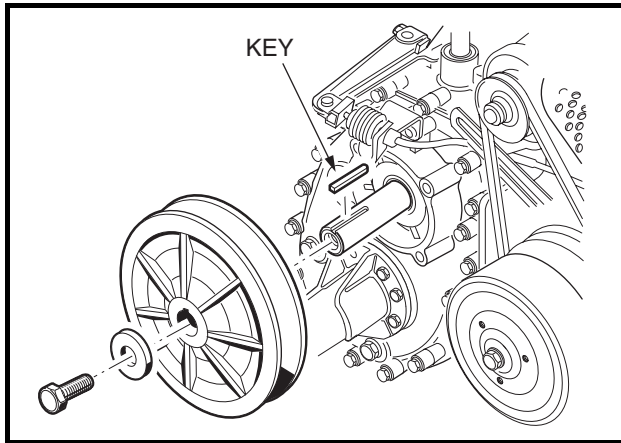

Figure 18-38 Driven Clutch

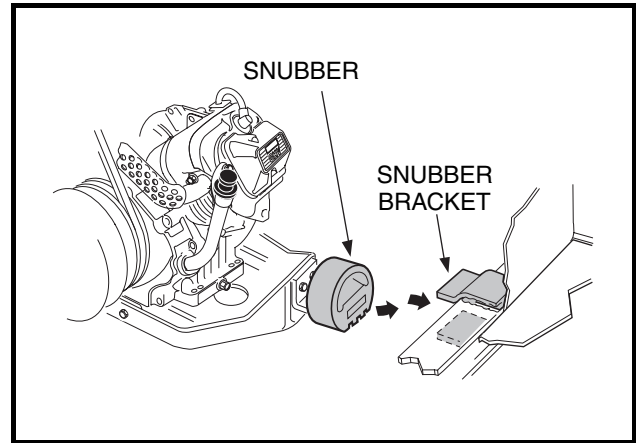

Figure 18-39 Snubber

13. Position the floor jack under the rear frame crossmember and raise the jack high enough to support the vehicle (Figure 18-40, Page 18-15). Make sure the vehicle is stable on the jack, then remove the jack stands.
14. After the jack stands are removed, lower the vehicle to approximately its normal height. Position the leaf springs in the front spring mounts and install the bolts and lock nuts. Tighten to 15 ft-lb (20.3 N·m).
15. Adjust the vehicle height with the floor jack to position the leaf springs for mounting in the shackles. Install the mounting bolts, and lock nuts (Figure 18-41, Page 18-15).

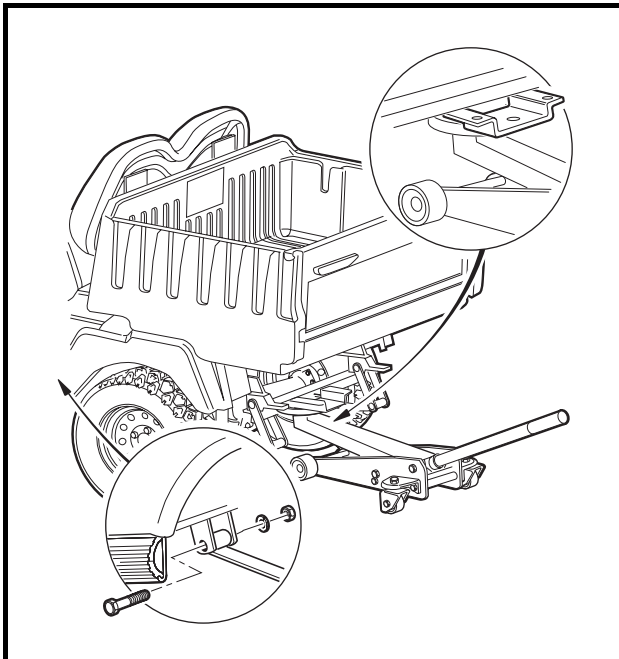

Figure 18-40 Leaf Springs

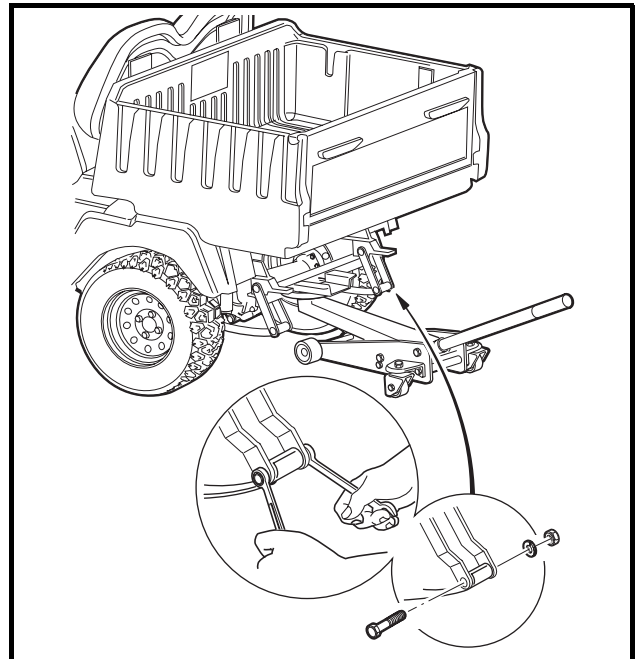

Figure 18-41 Leaf Springs and Shackles

16. Position shocks in the shock mounts and install cushions, mounting washers and nuts (**Figure 18-42, Page 18-16**). Tighten nuts until cushions expand to be the same diameter as the mounting washers.
17. Connect brake cables. **See Brake Cable Installation, Section 6, Page 6-11.**
18. Connect the engine kill switch wire (18-gauge white/black) to the bullet connector at the lower right front of the engine (**Figure 18-43, Page 18-16**).
19. Install three wire ties to secure the engine kill wire to the accelerator cable where they both route together on the passenger side of the engine.

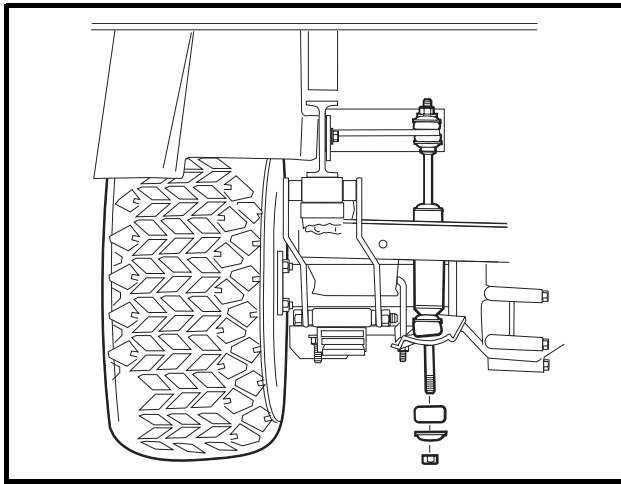

Figure 18-42 Shock Absorber

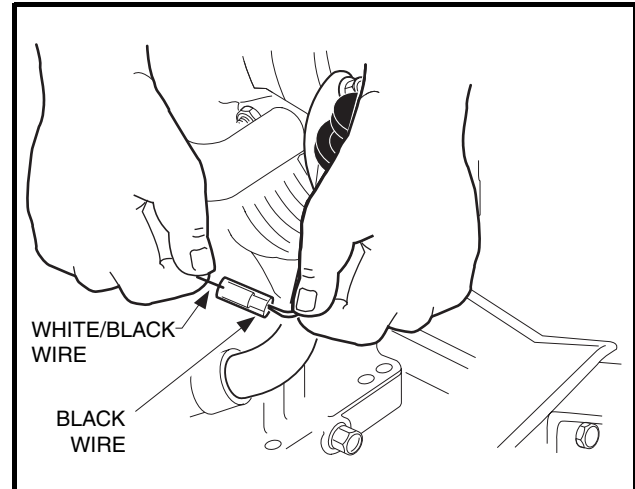

Figure 18-43 Ignition Kill Wire

20. Connect the oil level sensor wire (18-gauge yellow) to the jumper wire (**Figure 18-44, Page 18-16**).
21. Connect the 6-gauge white wire to the F2 post, the 6-gauge black ground wire to the A2 post and tighten both wires to 48 in-lb (5.4 N·m). Connect the 16-gauge yellow wire to the DF post on the starter/generator and tighten to 30 in-lb (3.4 N·m) (**Figure 18-45, Page 18-16**).

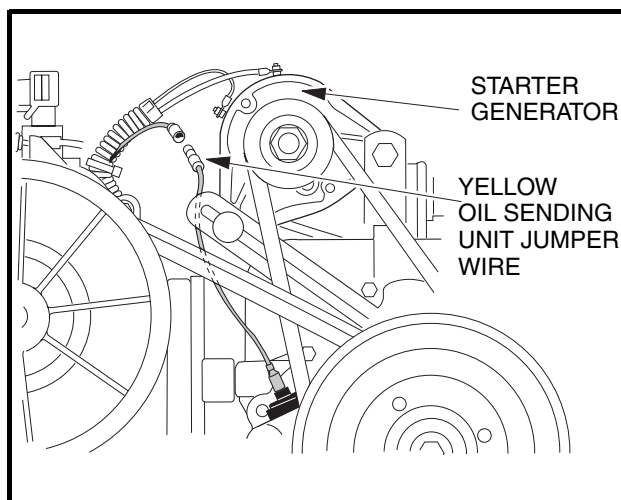

Figure 18-44 Oil Level Sensor Jumper wire

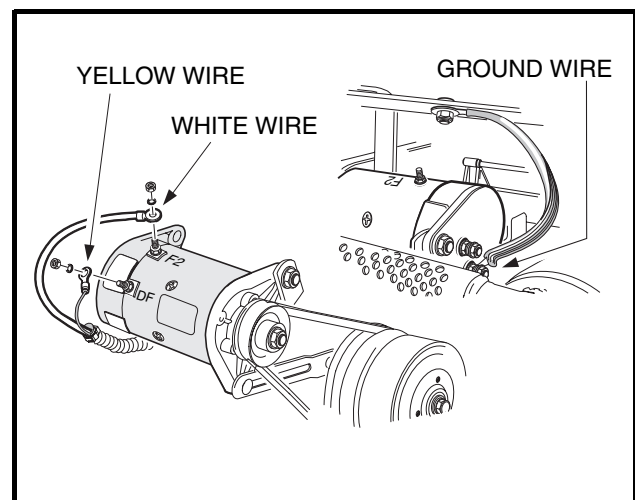

Figure 18-45 Starter/Generator

22. Connect the Forward/Reverse shifter and bracket to the transaxle.
 - 22.1. Install the three screws (2) securing the Forward/Reverse shifter cable bracket (1) to the transaxle and tighten them to 135 in-lb (15.3 N·m) (**Figure 18-35, Page 18-13**).
 - 22.2. Place the woodruff key (10) on the shifter shaft (9).
 - 22.3. Place the shifter lever (6) (aligned with the woodruff key) onto the Forward/Reverse shaft (9).
 - 22.4. Install the nut (3), washer (4), and bolt (7) on the Forward/Reverse shifter lever and tighten to 23 in lb (4.1 N·m).
23. Position the shifter cable in the shifter cable mounting bracket on the transaxle and tighten the mounting nuts to 22 ft-lb (29.8 N·m). Connect shifter cable rod end to the shifter arm (**Figure 18-46, Page 18-17**).
24. Attach the ground wire to the mounting screw on the oil filler tube mounting bracket and tighten to 50 in-lb (5.7 N·m) (**Figure 18-47, Page 18-17**).

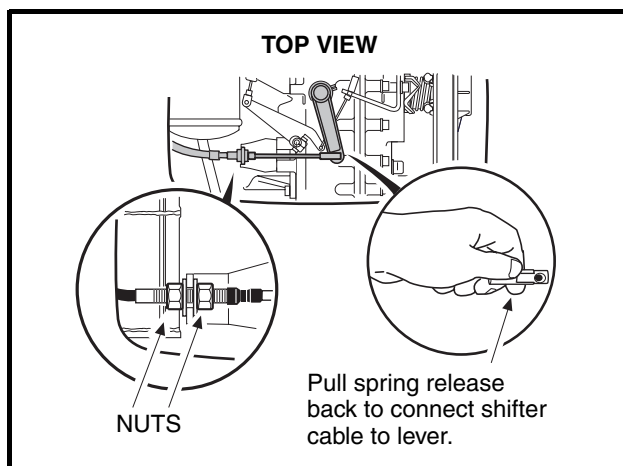

Figure 18-46 Connect Shifter Cable

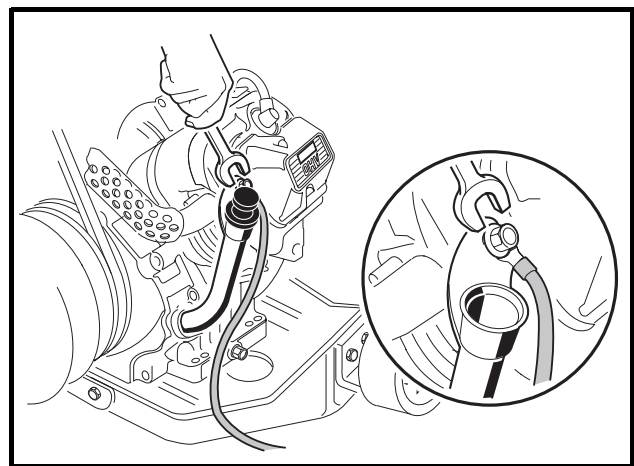

Figure 18-47 Engine Ground Wire

25. Connect accelerator cable to actuator cam in the electrical box. Position the accelerator cable in the mounting slot in the wall of the electrical box and tighten mounting nuts to 18 in-lb (2.0 N·m) (**Figure 18-48, Page 18-17**). Install electrical box cover and tighten mounting screw.
26. Remove the 1/4-inch bolt from the fuel line and connect the fuel line to the carburetor and secure with a hose clamp (**Figure 18-49, Page 18-17**).

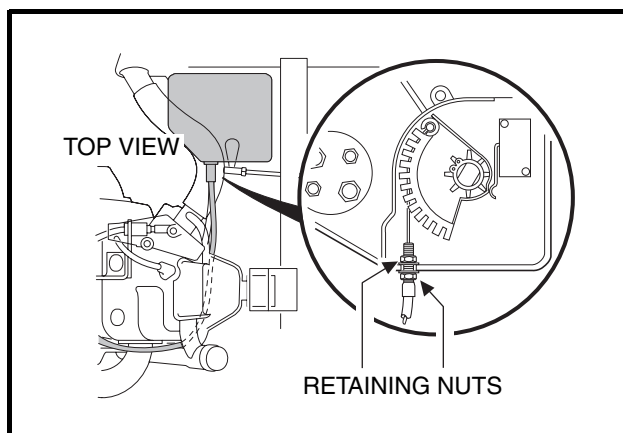

Figure 18-48 Connect Cable to Cam

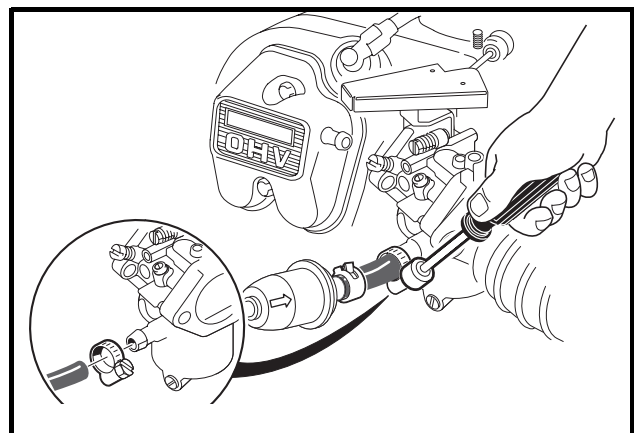

Figure 18-49 Connect Fuel Line

27. Connect the impulse line to the fuel pump and secure it with the hose clamp (**Figure 18-50, Page 18-18**).
28. Connect air intake hose to carburetor and secure hose clamp (**Figure 18-51, Page 18-18**).

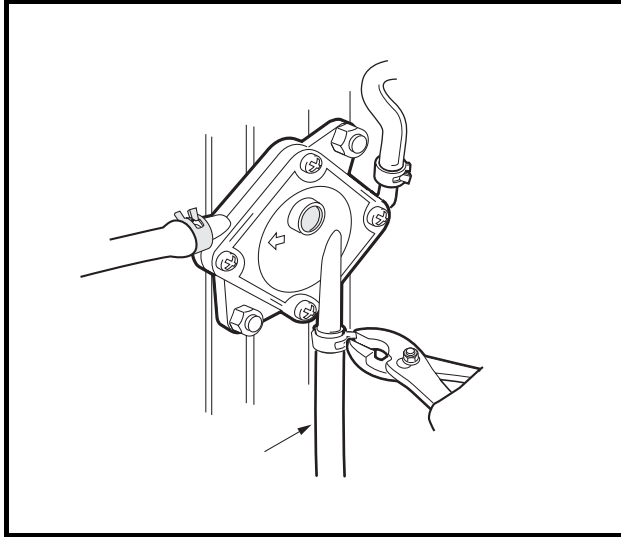

Figure 18-50 Impulse Line

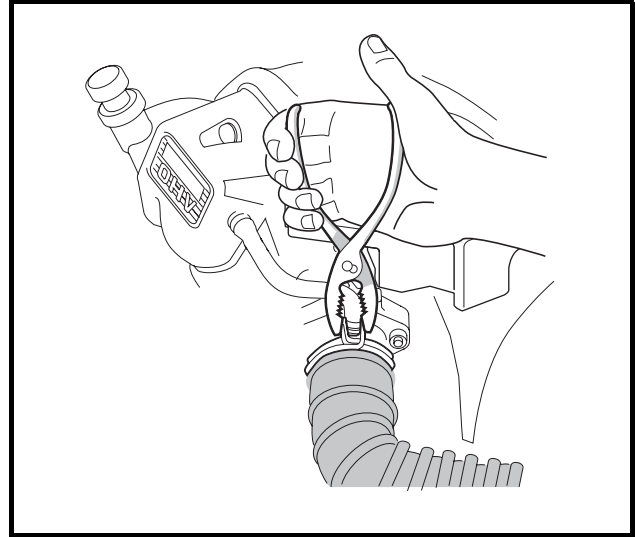

Figure 18-51 Air Intake Hose

29. Connect carburetor vent tube to carburetor and secure with hose clamp (**Figure 18-52, Page 18-18**).

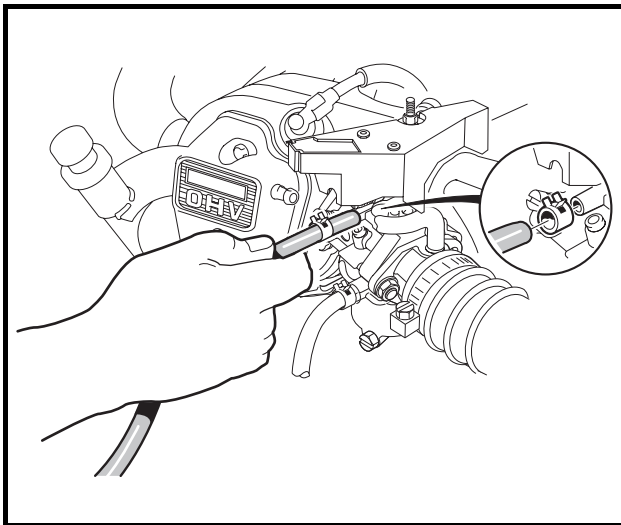

Figure 18-52 Carburetor Tube

30. Install transaxle drain plug and tighten to 21 ft-lb (28.5 N·m).
31. Fill transaxle with 27 oz. (0.8 liter) 80-90 Wt. API class GL-3 or 80-90 WT. AGMA class EP gear lube. Install and tighten the level indicator hole plug to 21 ft-lb (28.5 N·m).
32. Ensure that all wiring is secured properly. **See following WARNING.**

⚠ WARNING

- If wires are removed or replaced make sure wiring and wiring harness is properly routed and secured to vehicle frame. Failure to properly route and secure wiring could result in vehicle malfunction, property damage or personal injury.

33. Connect the spark plug wire.
34. Connect battery cables, positive (+) cable first, and tighten hardware to 144 in-lb (16 N·m) (**Figure 1-1, Page 1-3**). Coat terminals with Battery Terminal Protector Spray (CCI P/N 1014305) to minimize corrosion
35. Adjust the engine RPM setting. **See Engine RPM Adjustment on page 16-12.**

FORWARD/REVERSE SHIFTER CABLE

See General Warning on page 1-1.

If the Forward/Reverse shifter cable is damaged in any way, it must be replaced.

FORWARD/REVERSE SHIFTER CABLE REMOVAL

NOTE: Before removing cable, note cable routing and positions of wire ties or other devices securing the cable to the vehicle. When installed, cable must be routed and secured as it was originally.

1. Turn the key switch to the OFF position and remove the key, place the Forward/Reverse handle in the NEUTRAL position, and chock the wheels.
2. Disconnect the battery cables as instructed. **See WARNING “To avoid unintentionally starting...” in General Warning on page 1-2.**
3. Remove the ball joint socket (2) from the Forward/Reverse shifter assembly ball stud (3) (**Figure 18-54, Page 18-21**).
4. Remove the ball joint socket (10) from the shifter arm ball stud (11) on the transaxle.
5. Loosen the retaining nuts (5) on both ends of the cable and remove the wire tie.
6. Remove cable from the vehicle.

FORWARD/REVERSE SHIFTER CABLE INSTALLATION

1. From the Forward/Reverse shifter, route the cable toward the driver side of the vehicle so it lies against the side of the front body, turns 90° and passes to the driver side of air intake box, over the battery, beside the fender and then turns again to connect with the shifter arm on the transaxle (**Figure 18-53, Page 18-20**). Make sure cable does not touch muffler.
2. Secure the cable with a retaining nut (5) on each side of the shifter cable support bracket at the transaxle (**Figure 18-54, Page 18-21**). Tighten nuts to 22 ft-lb (29.8 N·m).
3. Secure the cable with a retaining nut (5) on each side of the shifter cable support bracket at the Forward/Reverse assembly. Tighten nuts to 43 in-lb (4.9 N·m).
4. Install the ball joint socket (10) on the shifter lever ball stud (11) on the transaxle.

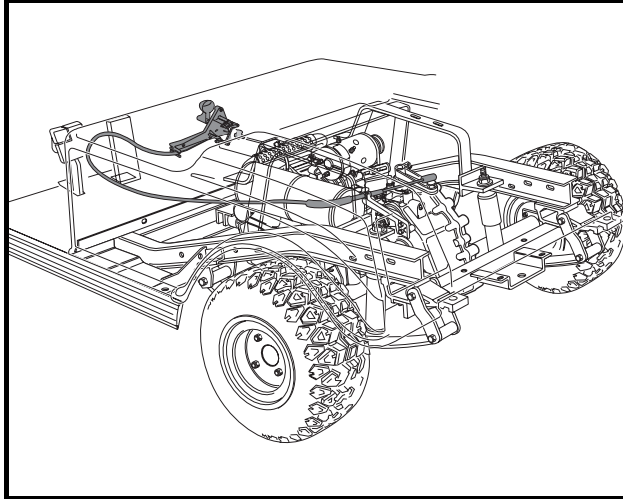

Figure 18-53 Forward/Reverse Cable Routing

5. Install the ball joint socket (2) on the Forward/Reverse shifter assembly ball stud (3) (**Figure 18-54, Page 18-21**).
6. Attach Forward/Reverse cable at cable retainer (7).
7. Install wire tie (8) to secure wire harness to cable at the support bracket near the Forward/Reverse shifter assembly. **See following WARNING.**

⚠ WARNING

- If wires are removed or replaced, make sure wiring and wiring harness is properly routed and secured. Failure to properly route and secure wiring could result in vehicle malfunction, property damage, personal injury, or death.

FORWARD/REVERSE SHIFTER CABLE ADJUSTMENT

With the shifter lever of the unitized transaxle in the NEUTRAL position (**Figure 18-54, Page 18-21**), the Forward/Reverse handle (9) should be straight up. For minor adjustments, the nut (1) may be loosened and the ball joint socket (2) rotated to get the proper adjustment (**Figure 18-54, Page 18-21**). **See following CAUTION.**

⚠ CAUTION

- Be sure threads of cable are engaged in ball joint socket at least 1/4 inch (6.35 mm). If ball joint socket comes loose from the cable, the Forward/Reverse shifter will not operate properly.

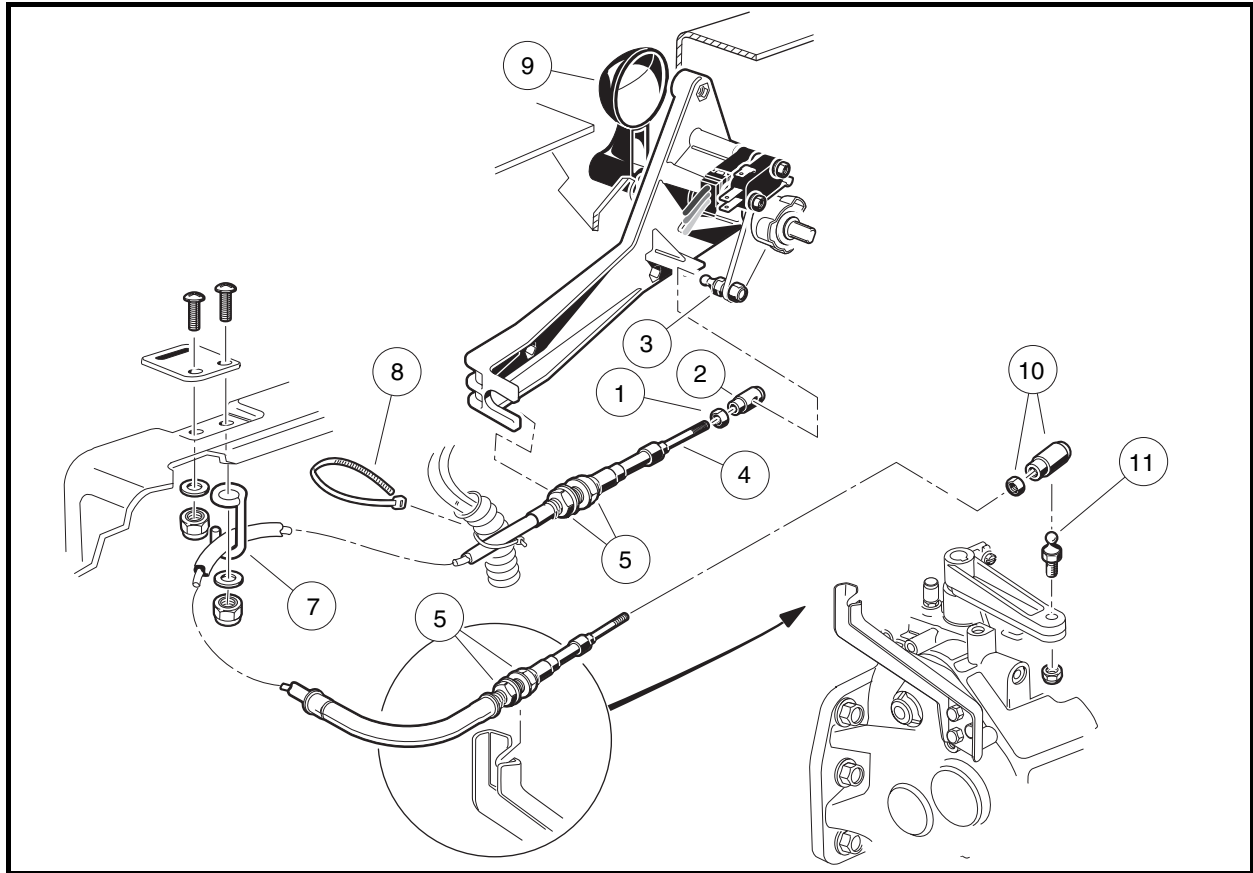

Figure 18-54 Forward/Reverse Shifter Cable

For major adjustments, the cable retaining nuts (5) must be loosened and adjusted. When the cable is properly adjusted, with the Forward/Reverse handle (9) (Figure 18-54, Page 18-21) in the NEUTRAL position, the shift lever of the transaxle will also be in the NEUTRAL position (Figure 18-55, Page 18-21). Retighten nuts at the transaxle to 22 ft-lb (29.8 N·m); retighten nuts at the Forward/Reverse assembly to 43 in-lb (4.9 N·m).

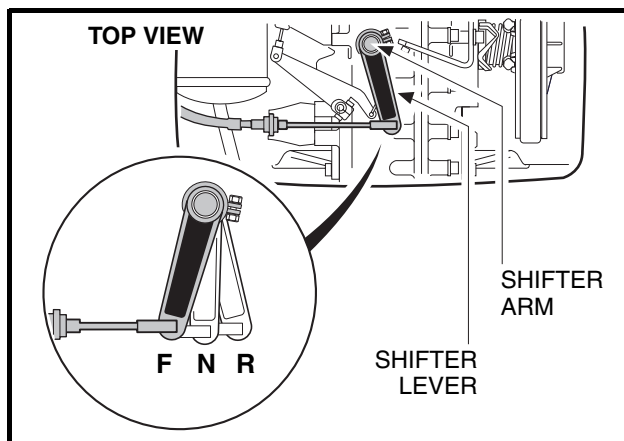

Figure 18-55 Forward/Reverse Positions

SECTION 19 – UNITIZED TRANSAXLE: 850 GASOLINE VEHICLE

⚠ DANGER

- See General Warning on page 1-1.

⚠ WARNING

- See General Warning on page 1-1.

GENERAL INFORMATION

Shifter Lever

A shifter lever, connected to a shifter arm, is used to change the gears to one of three shift positions: FORWARD (F), NEUTRAL (N), or REVERSE (R) (**Figure 19-1, Page 19-1**). Bring the vehicle to a complete stop before changing FORWARD or REVERSE direction.

Governor System

The governor system regulates vehicle ground speed. It is mounted inside the unitized transaxle and is driven by transaxle gears. If any of the governor linkages are removed in order to service other components, readjustment of the governor linkage is required. **See Governor Cable Installation and Adjustment on page 16-9.**

Unitized Transaxle Service

The unitized transaxle is extremely durable and should require very little service under normal operating conditions. The only service required is to maintain proper lubricant level. **See Periodic Lubrication Schedules, Section 10, Page 10-4.**

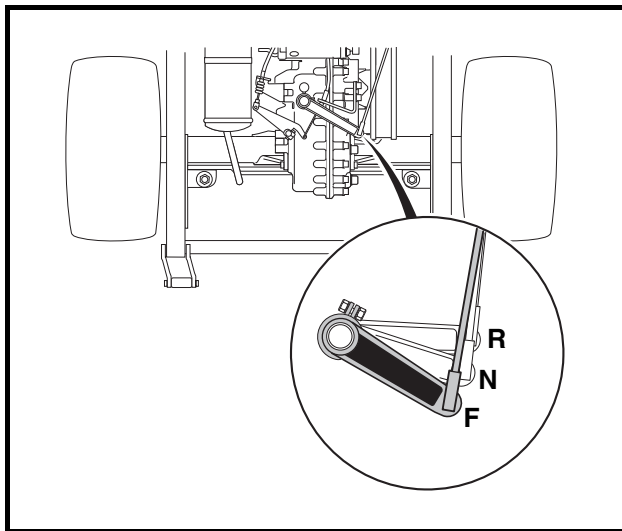

Figure 19-1 Shifter Positions (Top View)

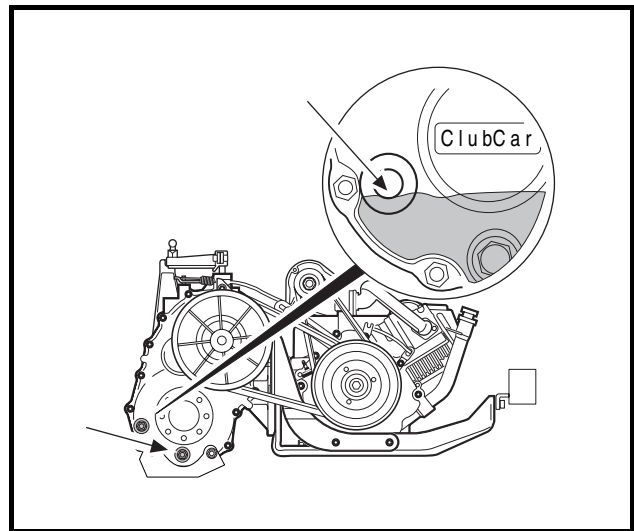

Figure 19-2 Lubricant Level (should be level with bottom of hole) and Drain Plug

Tools Required For This Section

Hydraulic floor jack (or chain hoist)	Torque wrench, 3/8-in. drive	1/2-in. combination wrench
Jack stands (2) (one ton capacity)	3/8-in. socket, 3/8-in. drive	9/16-in. combination wrench
Standard slip joint pliers	7/16-in. socket, 3/8-in. drive	Small flat blade screwdriver
External snap ring pliers (.047-in. tip)	1/2-in. socket, 3/8-in. drive	Medium flat blade screwdrivers (2)
90° Internal snap ring pliers (.090-in. tip)	9/16-in. socket, 3/8-in. drive	No. 2 phillips-head screwdriver
16-in. rolling head prybar	5/8-in. socket, 3/8-in. drive	1/4-in. nut driver
Plastic or rubber mallet	Axle seal tool (CCI P/N 1014162)	5/16-in. nut driver
Ratchet wrench, 3/8-in. drive	7/16-in. combination wrench	

LUBRICATION

There are two oil port plugs located on the right (driven clutch) side of the unitized transaxle (**Figure 19-2, Page 19-1**). When the vehicle is on a level surface, use the upper plug as a lubricant level indicator. Lubricant level should be even with the bottom of level indicator hole. Use the lower plug for draining. When draining lubricant, remove both plugs to allow the lubricant to drain faster. Clean and reinstall the drain plug and gasket before filling the transaxle with new lubricant. Use a funnel when filling the transaxle through the lubricant level indicator hole. Fill with 27 oz. (0.8 liter) 80-90 WT. API class GL or 80-90 WT. AGMA class 5 EP gear lubricant (or until lubricant begins to run out of the level indicator hole). Tighten the plug to 20 ft-lb (27.1 N·m).

AXLE SHAFT

See General Warning on page 1-1.

Removal of the unitized transaxle is not required for servicing or replacing axle shafts, axle bearings, or axle shaft oil seals. If the unitized transaxle is to be removed from the vehicle, do not remove the wheels, axle shafts, or axle tubes first. Instructions for removing the unitized transaxle from the vehicle begin on page 19-6.

AXLE SHAFT AND OIL SEAL REMOVAL

1. Turn the key switch to the OFF position and remove the key, place the Forward/Reverse handle in the NEUTRAL position, and chock the wheels.
2. Disconnect the battery cables as instructed. **See WARNING “To avoid unintentionally starting...” in General Warning on page 1-2.**
3. Loosen the lug nuts on the wheel to be removed.
4. Place chocks at the front wheels and lift the rear of the vehicle with a floor jack. Then place jack stands under the axle tubes to support the vehicle. **See WARNING “Lift only one end of the vehicle...” in General Warning, Section 1, Page 1-1.**
5. Remove the rear wheel and brake drum.
6. Use 90° internal snap ring pliers (0.090-in. tip) to remove internal retaining ring (1) from axle tube (**Figure 19-3, Page 19-3**).
7. Carefully pull the axle shaft (2) straight out of the axle tube (**Figure 19-3, Page 19-3**).

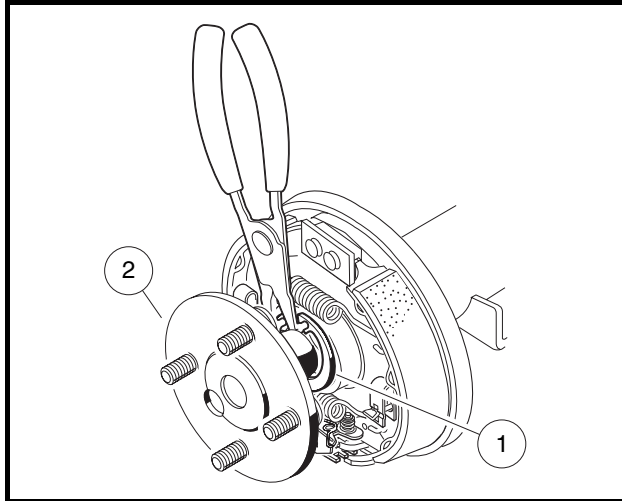

Figure 19-3 Retaining Ring

8. Position a 16-inch (40 cm) rolling head prybar (Figure 19-4, Page 19-3) under the inside lip of the seal and pull the oil seal out (Figure 19-5, Page 19-3). See following CAUTION.

⚠ CAUTION

- Do not scar or damage the inside surfaces of the tube when removing the oil seal. A damaged tube might have to be replaced.

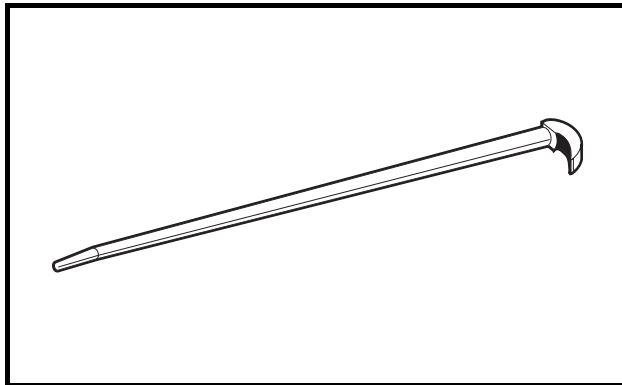

Figure 19-4 Rolling Head Prybar

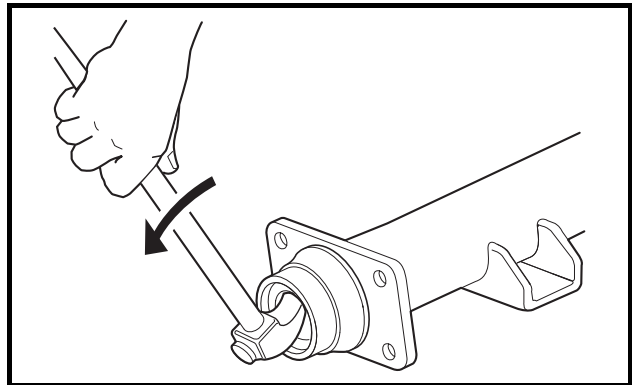

Figure 19-5 Seal Lip

9. Inspect the axle shaft assembly to be sure the bearing (71) and collar (73) have not slipped and are still seated against the shoulder on the axle shaft (Figure 19-6, Page 19-4).
10. Inspect the bearing. If the bearing is damaged or worn, replace it.

AXLE BEARING

Axle Bearing Removal

1. Use external retaining ring pliers (0.047-inch tip) to remove the retaining ring (74). Place a bearing puller wedge attachment (CCI P/N 1012812) on the axle shaft between the wheel mounting flange and the bearing (Figure 19-6, Page 19-4). See also Figure 19-7, Page 19-6. See following CAUTION.

CAUTION

- Do not tighten the bearing puller wedge attachment against the axle shaft. This could damage the axle shaft when pressing the bearing and collar off.

2. Press the bearing (71) and collar (73) off together (Figure 19-6, Page 19-4). See also Figure 19-7, Page 19-6. See following NOTE.

NOTE: It may be necessary to heat the collar to remove it.

Do not remove the large axle retaining ring (70) from the axle (Figure 19-6, Page 19-4). Since the inner diameter of the retaining ring (70) is smaller than the outer diameter of the bearing (71), the ring must be in place on the axle before a new bearing and collar are pressed on.

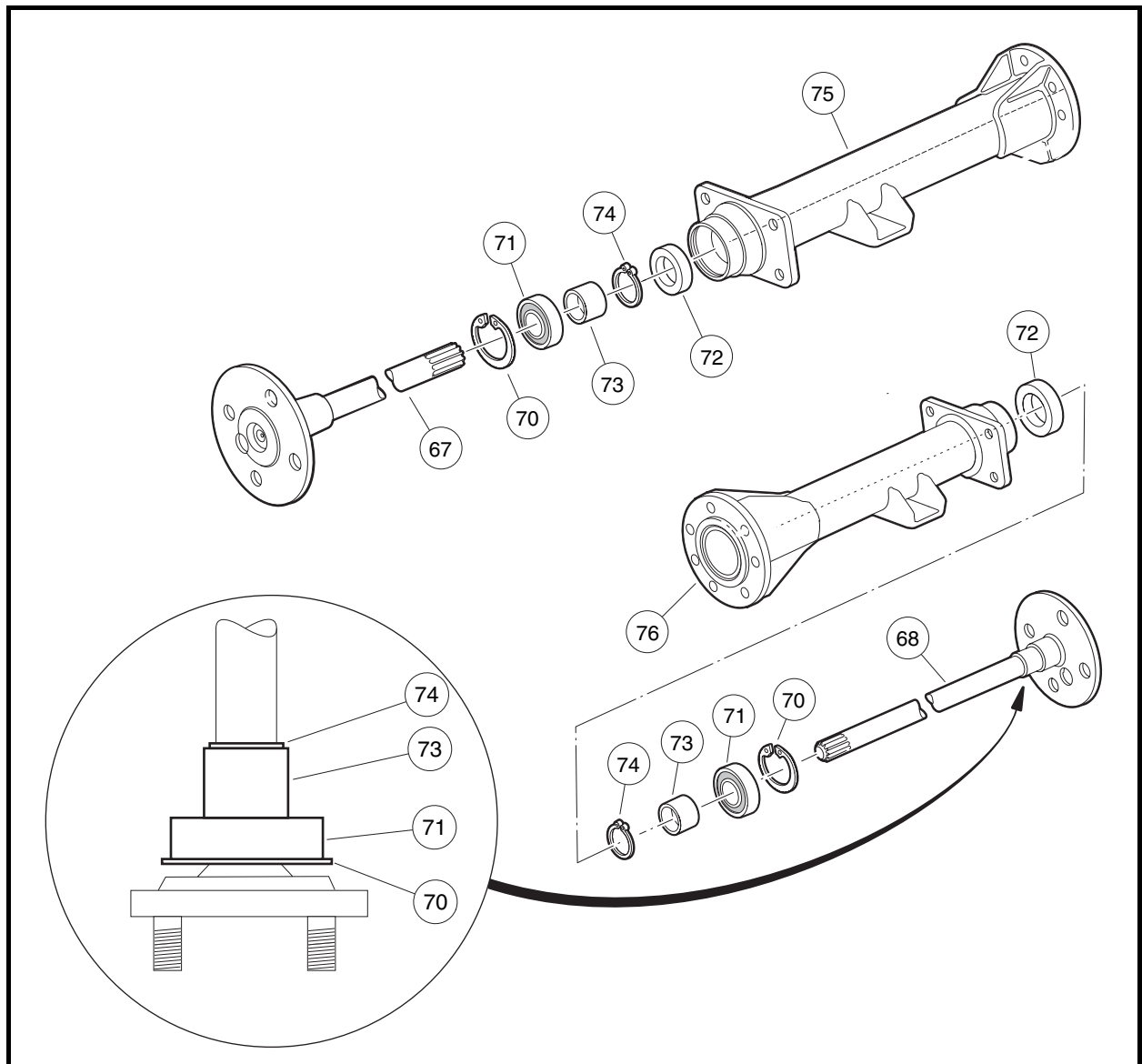

Figure 19-6 Differential Gear Case and Axle Tubes

Axle Bearing Installation

1. Ensure that the retaining ring (70) is loosely placed on the axle shaft. **See preceding NOTE.**
2. Install a new axle bearing (71) on axle (67 or 68). Push bearing onto axle until bearing is flush against axle shoulder (**Figure 19-6, Page 19-4**).
3. Apply two drops of Loctite 271[®] to inside of the collar. **See following CAUTION.**

⚠ CAUTION

- Apply Loctite 271 to the inside of the collar only, not to the shaft, so that the Loctite will be pushed away from the bearing as the collar and bearing are pressed on. If Loctite gets on or in the bearing, the bearing must be replaced.
- The collar should be removed no more than two times. If a collar is removed a third time, the shaft and collar will not fit properly.

4. Place a new sealed bearing (71) on shaft (67 or 68) (**Figure 19-6, Page 19-4**).
5. Install collar (73) onto axle shaft. Place axle assembly on bearing puller wedge attachment and press collar onto axle.
6. Place the bearing puller wedge attachment against collar and press both bearing and collar onto shaft. **See following CAUTION.**

⚠ CAUTION

- If the bearing was removed from the shaft, replace it with a new one.
- Do not tighten the bearing puller wedge attachment against the axle shaft. This could damage the axle shaft when the bearing and collar are pressed on.

7. Use external snap ring pliers (0.047-in. tip) to install collar retaining ring (74) (**Figure 19-6, Page 19-4**).

AXLE SHAFT INSTALLATION

1. Clean bearing and seal seats in axle tube (75 or 76) (**Figure 19-6, Page 19-4**).
2. Place a new oil seal (72) in axle tube with seal lip facing inside of the axle tube (**Figure 19-6, Page 19-4**). Use an axle seal tool (CCI P/N 1012811) to press it in until it seats firmly in position (**Figure 19-8, Page 19-6**). **See following NOTE.**

NOTE: The new seal can be installed by tapping the axle seal tool with a mallet.

⚠ CAUTION

- Clean any residual oil from the exposed end of the axle shaft and from the oil seal area prior to installing the axle shaft.
3. Clean the axle shaft and splines and then insert the shaft, splined end first, through the seal and into the axle tube. Be careful not to damage the seal. Then advance the shaft through the inner bearing and rotate it to align the shaft splines with the splined bore of the differential side gear. Continue advancing the shaft until the bearing seats against the axle tube shoulder.
 4. Install the bearing retaining ring (70) in the axle tube (**Figure 19-6, Page 19-4**). **See also Figure 19-3, Page 19-3.**

5. Place a 1/4 to 3/8-inch (6-10 mm) diameter rod against the retaining ring and tap lightly at four to five locations to ensure it is properly seated. **See following WARNING.**

⚠ WARNING

- **Be sure bearing retaining ring is properly seated in its groove. If ring is not properly installed, the axle assembly will separate from the transaxle and damage the axle assembly and other components. Loss of vehicle control could result in severe personal injury or death.**

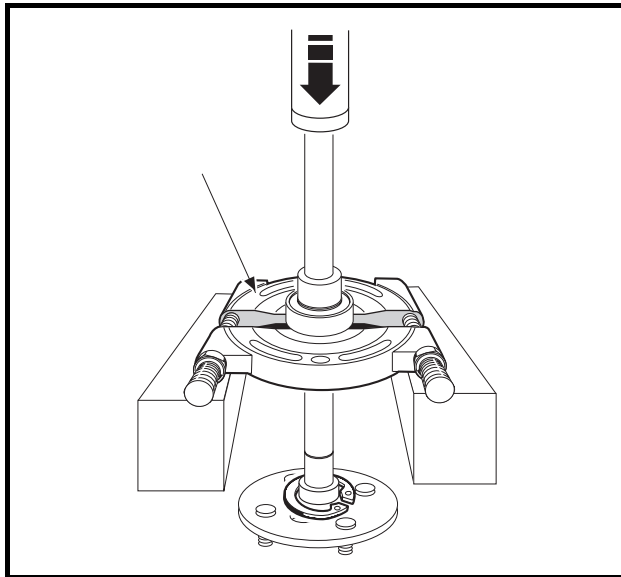

Figure 19-7 Press Bearing and Collar From Shaft Using Bearing Puller Wedge Attachment

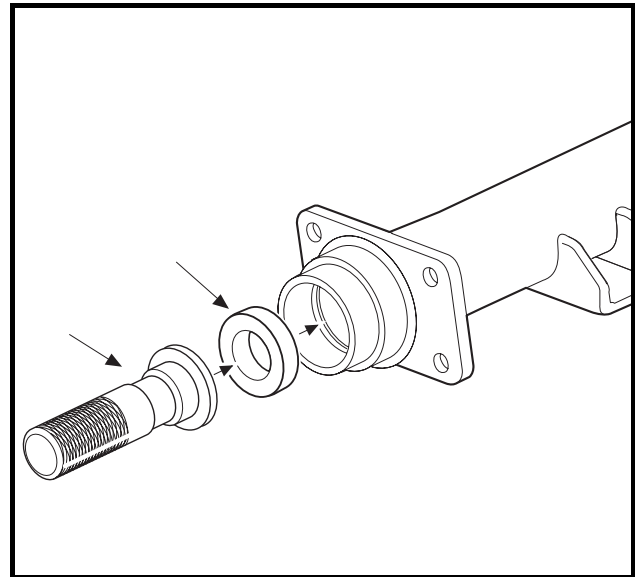

Figure 19-8 Axle Seal and Seal Tool

UNITIZED TRANSAXLE REMOVAL

See General Warning on page 1-1.

1. Turn the key switch to the OFF position and remove the key, and place the Forward/Reverse handle in the NEUTRAL position.
2. Disconnect the battery cables as instructed. **See WARNING “To avoid unintentionally starting...” in General Warning on page 1-2.**
3. Close the fuel shut-off valve on fuel tank (**Figure 16-18, Page 16-25** or **Figure 16-19, Page 16-25**).
4. Detach all wires, hoses, etc. connecting the powertrain to the vehicle.
 - 4.1. Disconnect the carburetor vent tube from the carburetor (**Figure 19-9, Page 19-7**).
 - 4.2. Disconnect the air intake hose from the carburetor (**Figure 19-10, Page 19-7**).

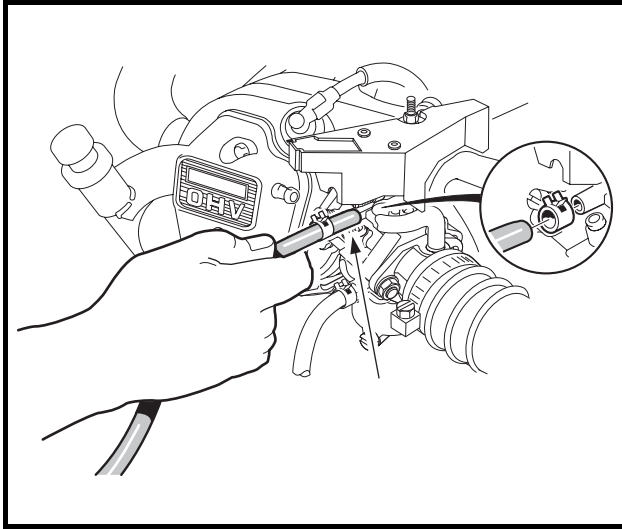

Figure 19-9 Fuel Vent Tube

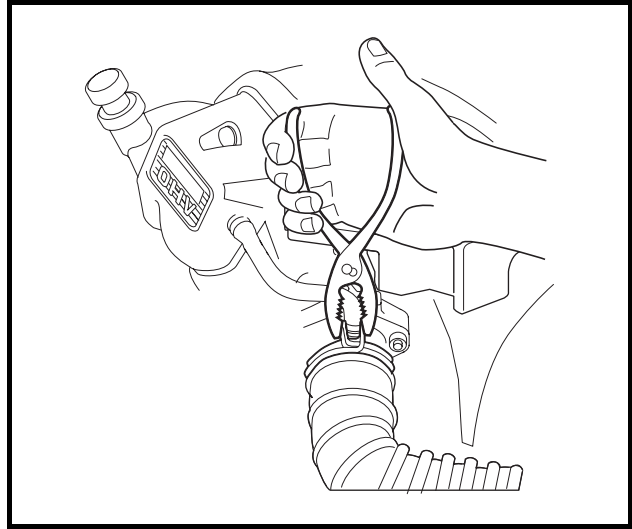

Figure 19-10 Air Intake Hose

- 4.3. Disconnect impulse line from fuel pump (**Figure 19-11, Page 19-7**).
- 4.4. Loosen the hose clamp and then disconnect the fuel line from the carburetor. To prevent spilling fuel, the disconnected end of the line can be plugged with a 1/4-inch bolt (**Figure 19-12, Page 19-7**).

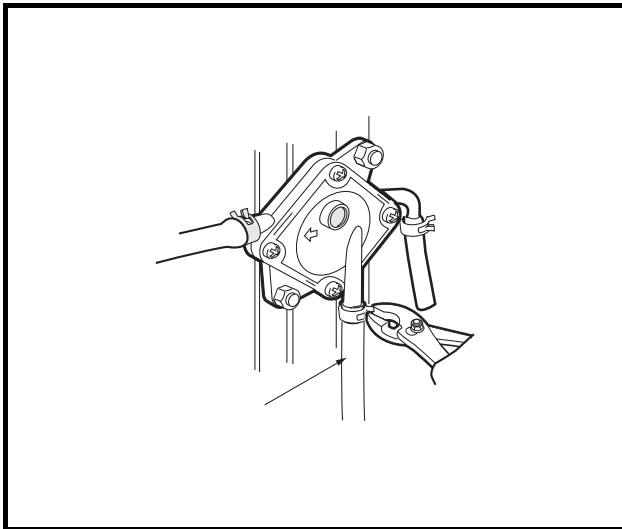

Figure 19-11 Impulse Line

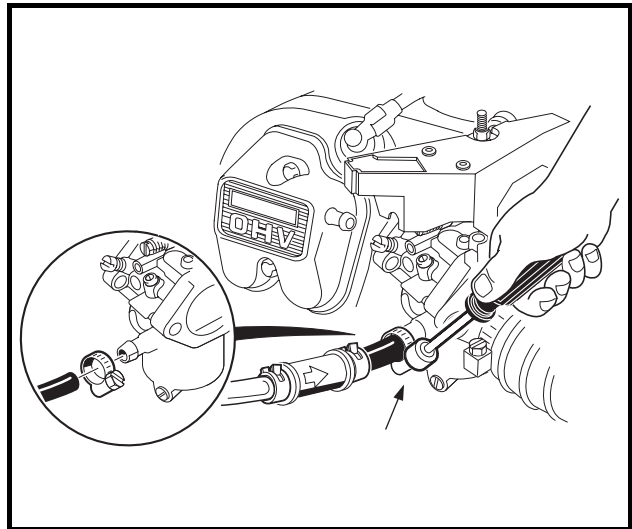

Figure 19-12 Fuel Line

- 4.5. Remove the cover from the electrical component box. Then loosen the hardware securing the accelerator cable to the box. Disconnect the cable from the actuator cam and remove it from the box (**Figure 19-13, Page 19-8**).
- 4.6. Remove retaining nut and disconnect the engine ground wire from the oil filler tube mounting bracket (**Figure 19-14, Page 19-8**).

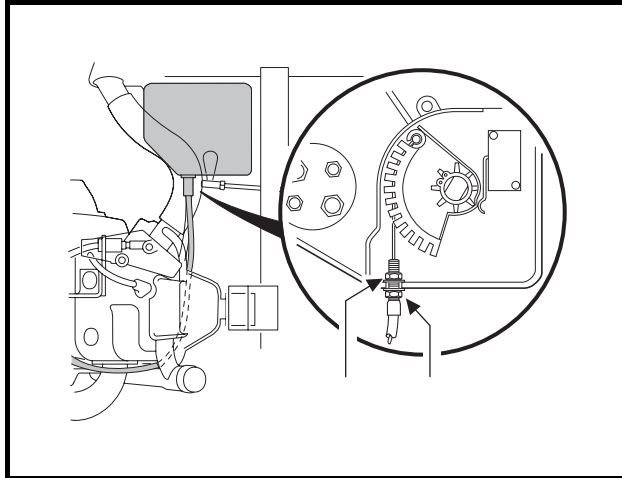

Figure 19-13 Throttle Cable and Retaining Nuts (Top View)

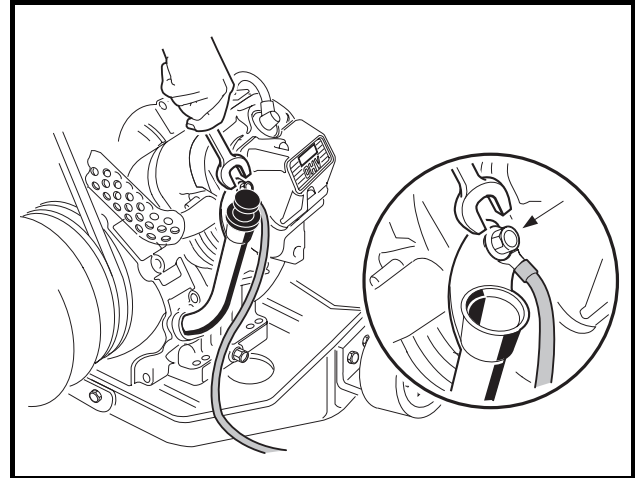

Figure 19-14 Engine Ground Wire and Retaining Nut

- 4.7. Loosen nuts securing shifter cable to shifter cable mounting bracket. Then disconnect the shifter cable rod end from the shifter arm on the unitized transaxle and remove the cable from the cable mounting bracket (**Figure 19-15, Page 19-8**).
- 4.8. Mark for identification and then disconnect the 6-gauge white wire (F2 post), 6-gauge black ground wire (A2 post), and 16-gauge yellow wire (DF post) from starter/generator (**Figure 19-16, Page 19-8**).

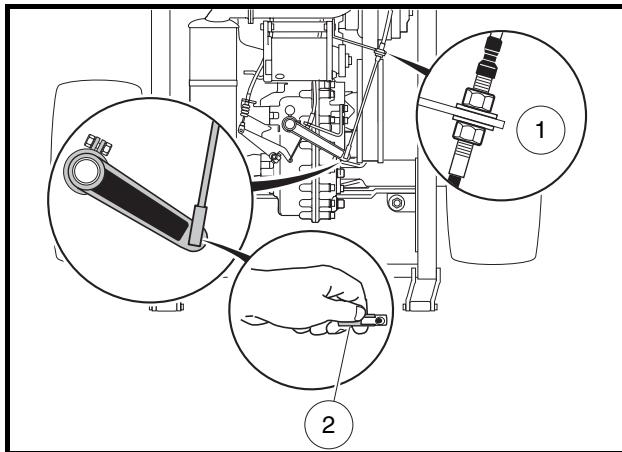

Figure 19-15 Shifter Cable (Top View)

1. Loosen nuts. 2. Pull spring release back to remove shifter cable from lever.

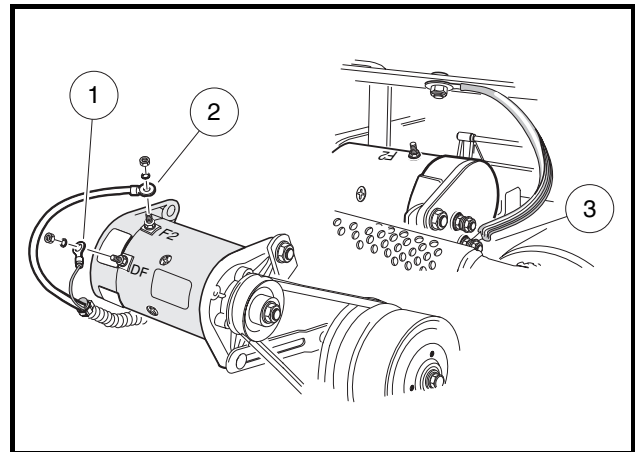

Figure 19-16 Generator Wires

1. Yellow Wire 2. White Wire 3. Ground Wire at A2 Terminal

- 4.9. Disconnect the engine oil level sensor wire (18-gauge yellow) at the connector just to the rear of the starter/generator) (**Figure 19-17, Page 19-9**).
- 4.10. Disconnect the engine kill switch wire (18-gauge white/black) from the bullet connector at the lower right front of the engine (**Figure 19-18, Page 19-9**).
- 4.11. Cut away the wire ties securing the engine kill wire at the lower right front of the engine (below the exhaust header), the wire harness at the governor cable bracket, and the wire harness to the plate beneath the muffler.

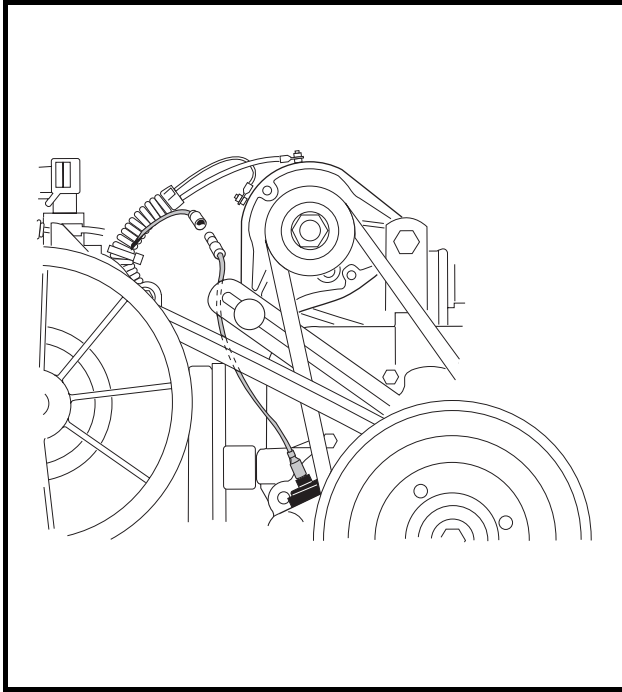

Figure 19-17 Oil Level Sensor Jumper Wire

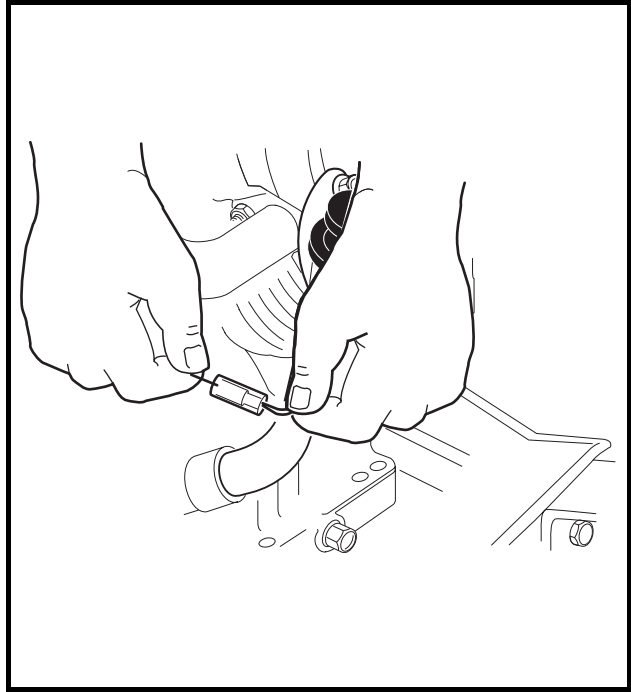

Figure 19-18 Ignition Kill Wire

5. Disconnect the brake cables.

5.1. Remove bow tie pins (1), brake cable clevis pins (2), and E-clips (3) (Figure 19-19, Page 19-9).

5.2. Remove the cable from the cable support bracket (Figure 19-19, Page 19-9).

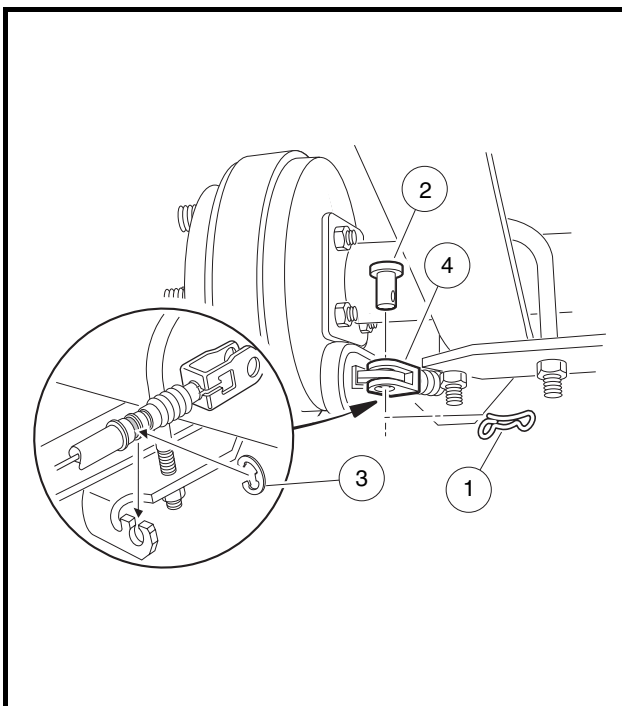

Figure 19-19 Brake Cable (Rear View)

6. Remove the lower shock mounting hardware from both rear shocks (**Figure 19-20, Page 19-10**).
7. Position a floor jack under the vehicle frame crossmember or trailer hitch mount (**Figure 19-21, Page 19-10**).

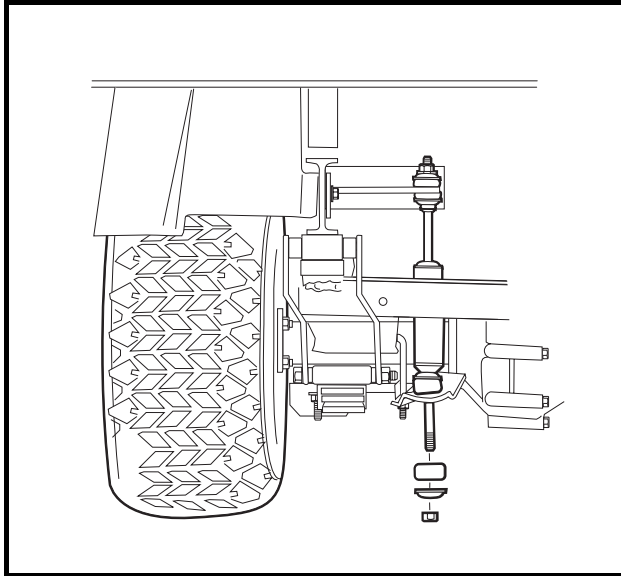

Figure 19-20 Shock Absorbers

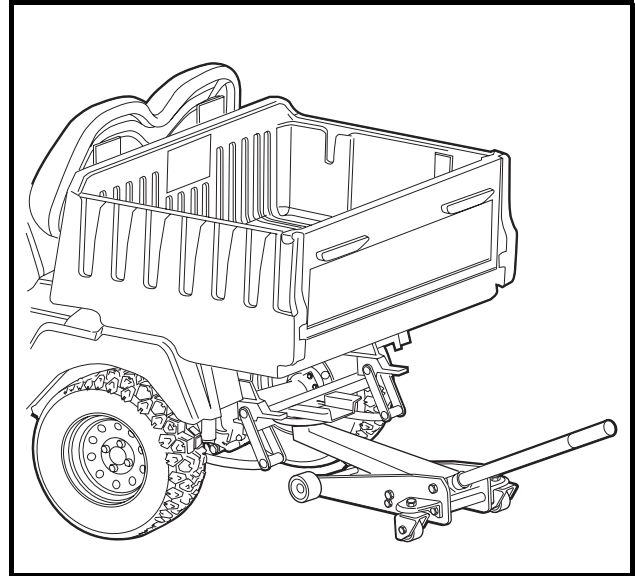

Figure 19-21 Floor Jack Positioned Under Hitch Bracket

8. Raise vehicle just enough to relieve tension from leaf springs, then remove the bolts securing the leaf springs to the shackles (**Figure 19-22, Page 19-10**).
9. Remove the bolts securing the leaf springs to their front mounts (**Figure 19-23, Page 19-10**).

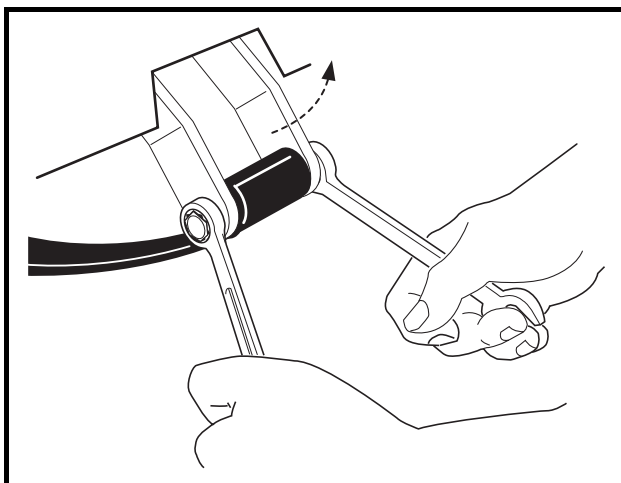

Figure 19-22 Rear Shackles

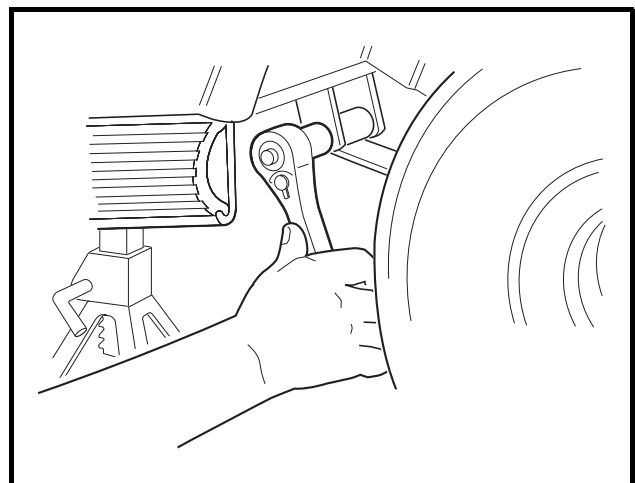

Figure 19-23 Spring Retainer Bolts

10. Continue raising vehicle until frame or trailer hitch is higher than the top of the unitized transmission (enough to allow transaxle and engine to be rolled under and out of vehicle) (**Figure 19-24, Page 19-11**).

11. Position jack stands, adjusted to support the vehicle at this height, under the frame crossmember between the leaf spring mounts and side stringers, just forward of each rear wheel. Lower the floor jack to allow the jack stands to support the vehicle (**Figure 19-25, Page 19-11**).

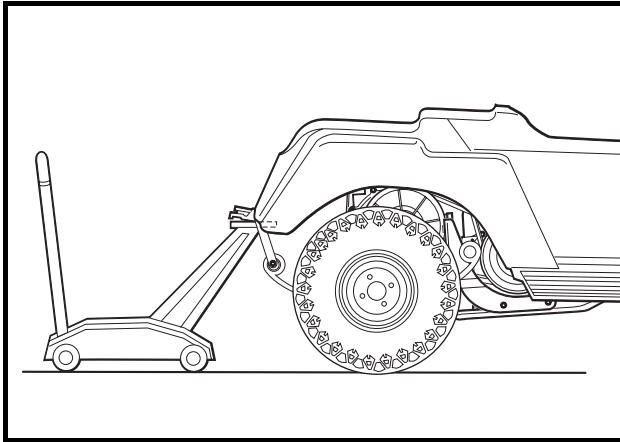

Figure 19-24 Raise Vehicle

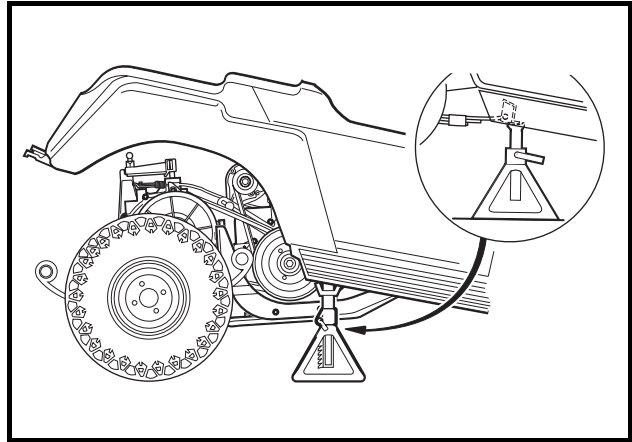

Figure 19-25 Position Jack Stands On Both Sides of Frame

12. Pull the floor jack from beneath the vehicle and move it away.
13. Carefully lift the snubber out of the snubber bracket in the vehicle frame and lower it to the floor (**Figure 19-26, Page 19-11**). The powertrain should be completely disconnected from the vehicle and resting on the floor.
14. Grasp the ends of the leaf springs at the rear of the vehicle and roll the powertrain out from under the vehicle (**Figure 19-27, Page 19-11**).

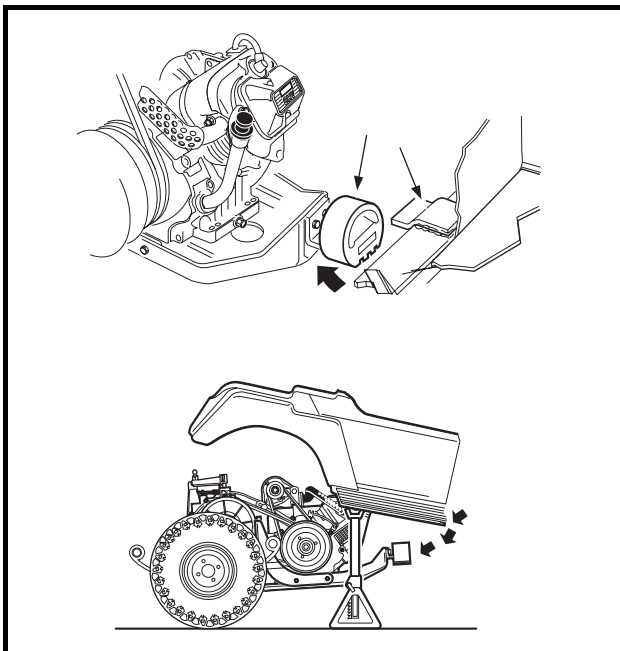

Figure 19-26 Snubber and Bracket

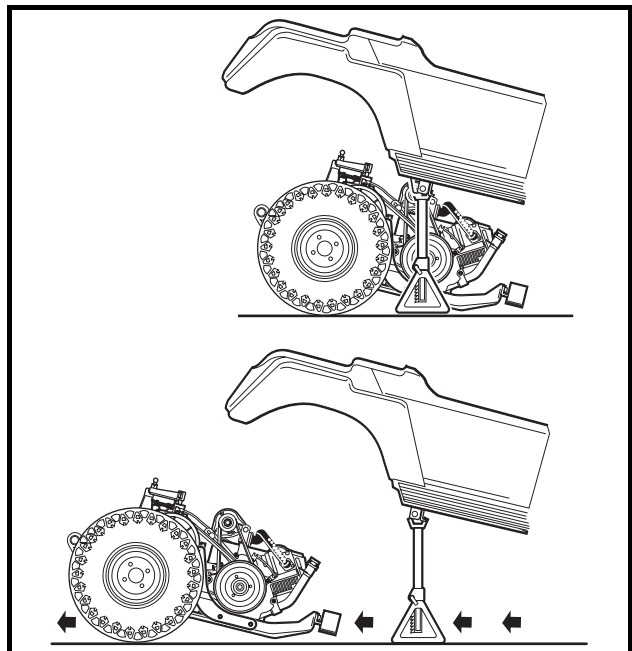

Figure 19-27 Remove Powertrain

15. Place blocks under the engine pan so they will completely support the engine and keep it **level to the floor (Figure 19-28, Page 19-12)**. See following **NOTE**.

NOTE: Place the blocks so they will support the engine when the transaxle is detached and moved away from the engine.

16. Remove the drive belt.

- 16.1. Grasp belt midway between drive and driven clutch and pull up on belt to force the driven clutch sheaves apart. Roll the belt counterclockwise while pulling it off driven clutch (**Figure 19-29, Page 19-12**).

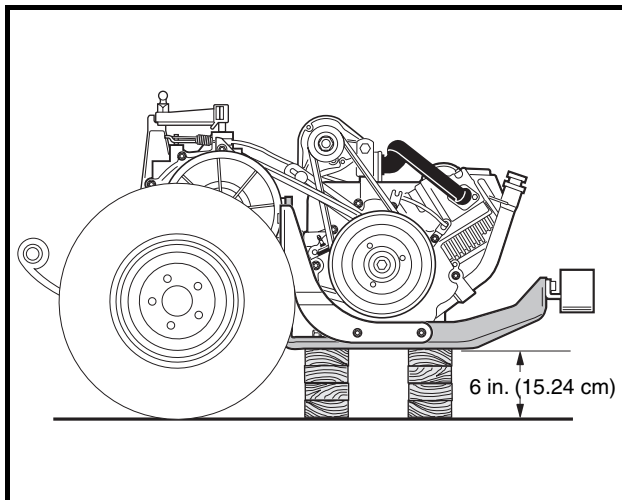

Figure 19-28 Position Powertrain on Wood Blocks

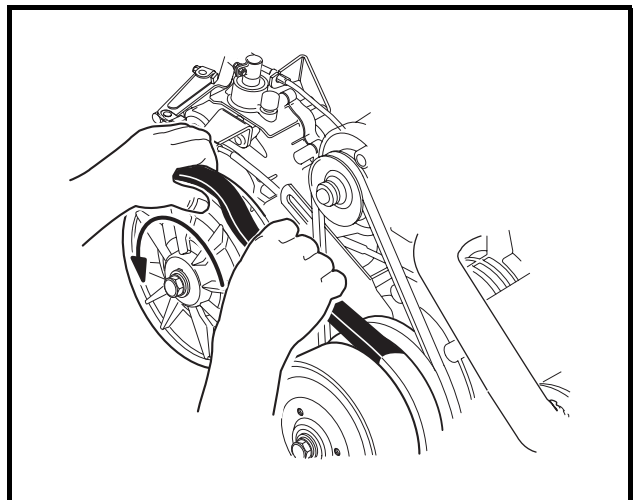

Figure 19-29 Remove Drive Belt

17. Remove the driven clutch retaining bolt and remove the driven clutch from the unitized transaxle (**Figure 19-30, Page 19-12**).

18. Loosen, but do not remove, the governor arm retaining bolt (1) (**Figure 19-31, Page 19-12**). Remove the governor arm from the shaft. Do not disconnect cables.

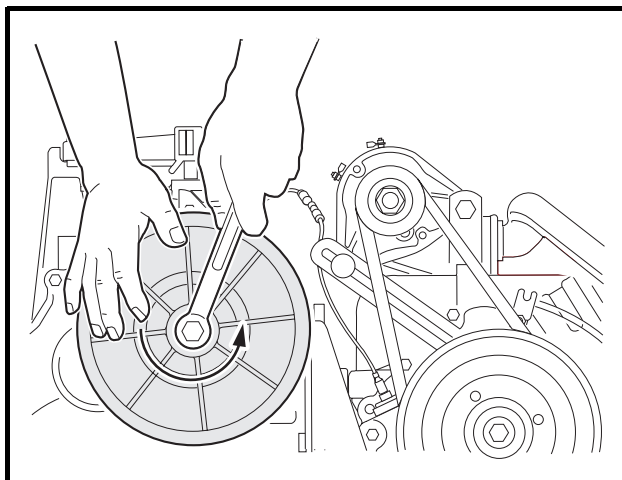

Figure 19-30 Driven Clutch

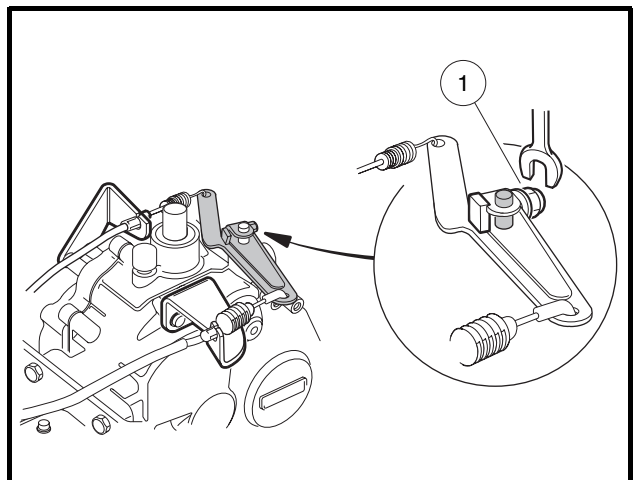

Figure 19-31 Governor Arm

19. Remove screws (1) securing the governor cable bracket to transaxle (**Figure 19-32, Page 19-13**).
20. Remove screws (1) securing the accelerator cable bracket to transaxle (**Figure 19-33, Page 19-13**).

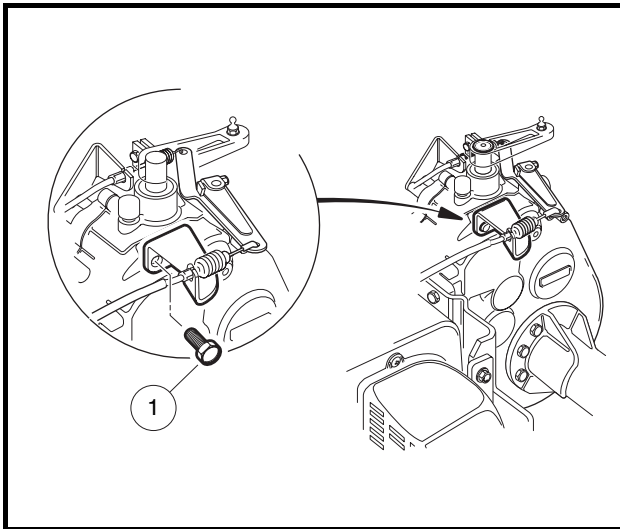

Figure 19-32 Governor Cable Bracket

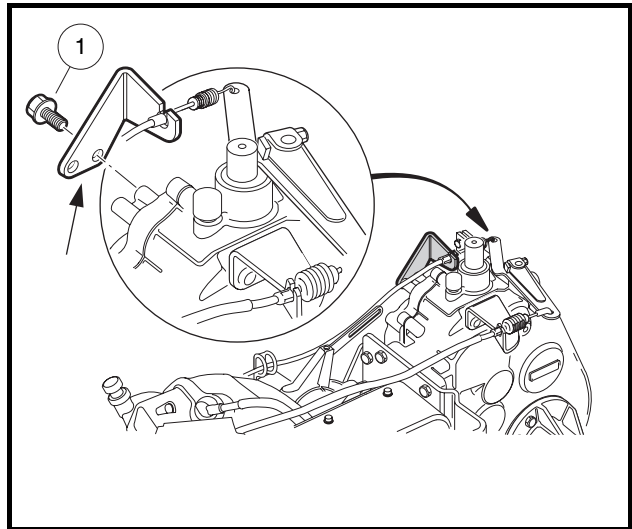

Figure 19-33 Accelerator Cable Bracket

21. Remove the six bolts mounting the unitized transaxle to the engine.
 - 21.1. Remove four transaxle mounting bolts (one at each corner of the transaxle mounting plate) (**Figure 19-34, Page 19-13**).
 - 21.2. Remove two middle transaxle mounting nuts from the engine block studs.
22. Remove leaf springs, wheels and brake assemblies from the transaxle.

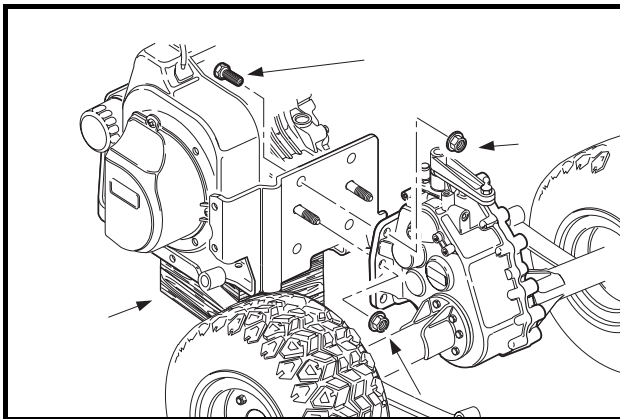

Figure 19-34 Transaxle Mounting

UNITIZED TRANSAXLE INSTALLATION

See General Warning on page 1-1.

1. Install the wheels. See **Wheel Installation, Section 8, Page 8-1**.
2. Install the leaf springs. See **Leaf Spring Installation – All Vehicles, Section 9, Page 9-4**.
3. Position the transaxle mounting plate on the two mounting studs at the rear of the engine, and then install the two mounting nuts finger tight (**Figure 19-35, Page 19-14**).
4. Install the remaining four mounting bolts and four nuts (one bolt and nut at each corner of the mounting plate) finger tight.
5. Tighten the four corner nuts (with bolts) to 30 ft-lb (40.7 N·m). Tighten the two center nuts (on the engine block studs) to 17 ft-lb (23.1 N·m) (**Figure 19-35, Page 19-14**).
6. Install the accelerator cable bracket on transaxle case. Tighten the mounting screws to 134 in-lb (15.1 N·m) (**Figure 19-33, Page 19-13**).

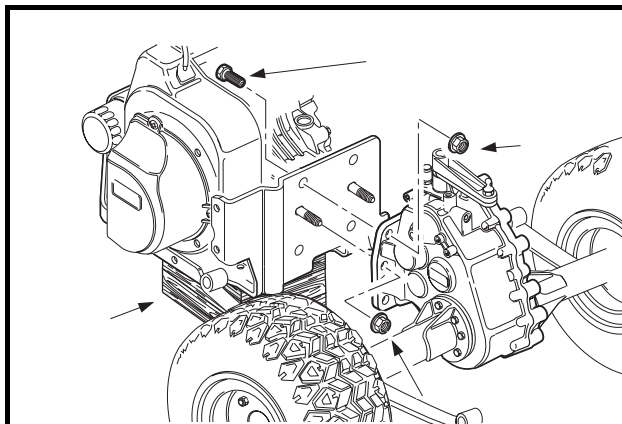

Figure 19-35 Transaxle Mounting

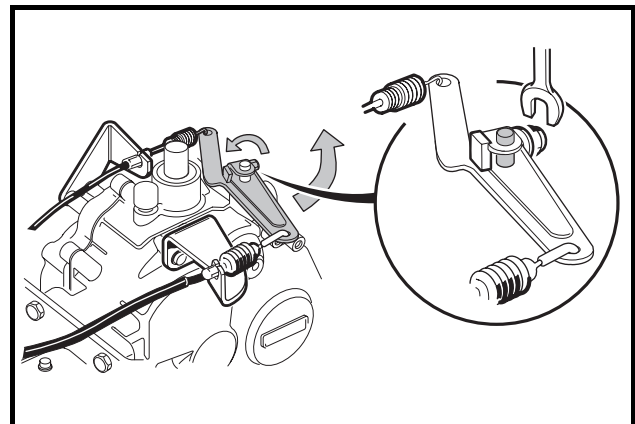

Figure 19-36 Governor Arm

7. Install the governor cable bracket on transaxle case. Tighten the mounting screws to 134 in-lb (15.1 N·m) (**Figure 19-32, Page 19-13**).
8. Install governor lever arm on governor shaft (**Figure 19-36, Page 19-14**).
 - 8.1. With the governor lever arm loose on the governor shaft, turn the governor arm shaft counterclockwise until it stops. Then pull the governor lever arm rearward until the carburetor throttle is in the “wide open throttle” (WOT) position (**Figure 19-36, Page 19-14**).
 - 8.2. While holding the arm and shaft in the fully counterclockwise position, tighten the governor arm lever nut to 35 in-lb (4.0 N·m) (**Figure 19-36, Page 19-14**).
9. Install the key onto the input shaft (**Figure 19-37, Page 19-15**).
10. Position the driven clutch on the transaxle input shaft and install the washer (yellow side facing out) and mounting bolt. Tighten the mounting bolt to 14 ft-lb (19.0 N·m) (**Figure 19-37, Page 19-15**).
11. Install the drive belt. See **Drive Belt Installation, Section 20, Page 20-3**.

12. Remove the blocks from under the engine and roll the powertrain into position under the vehicle. Then lift the front of the powertrain and place the snubber into the snubber bracket in the vehicle frame (Figure 19-38, Page 19-15).

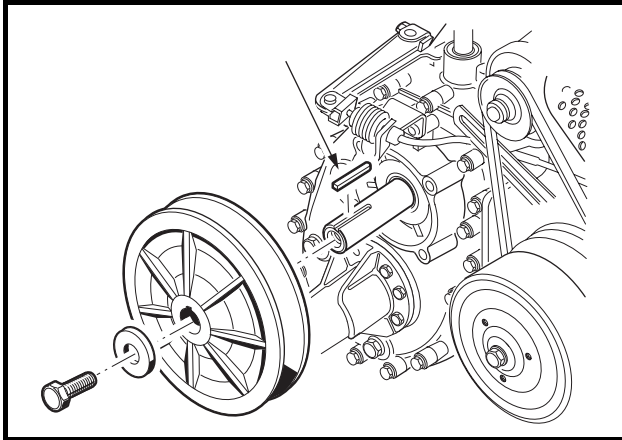

Figure 19-37 Driven Clutch and Key

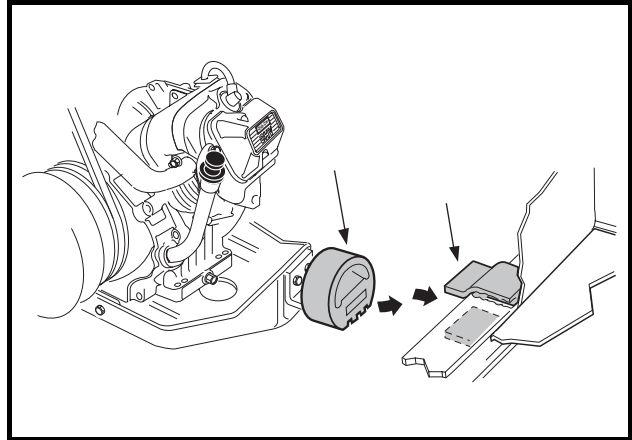

Figure 19-38 Snubber and Bracket

13. Position the floor jack under the rear frame crossmember and raise the jack high enough to support the vehicle (Figure 19-39, Page 19-15). Make sure the vehicle is stable on the jack, then remove the jack stands.
14. After the jack stands are removed, lower the vehicle to approximately its normal height. Position the leaf springs in the front spring mounts and install the bolts and lock nuts. Tighten to 15 ft-lb (20.3 N·m).
15. Adjust the vehicle height with the floor jack to position the leaf springs for mounting in the shackles. Install the mounting bolts, and lock nuts (Figure 19-40, Page 19-15).

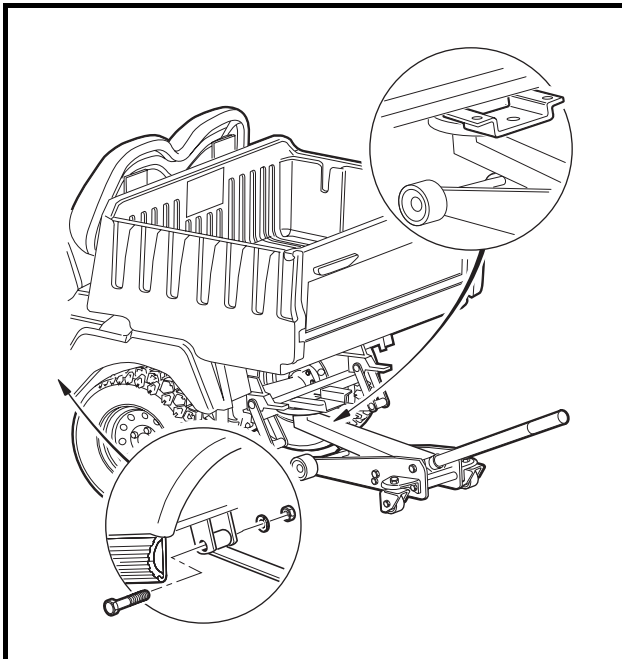

Figure 19-39 Leaf Springs

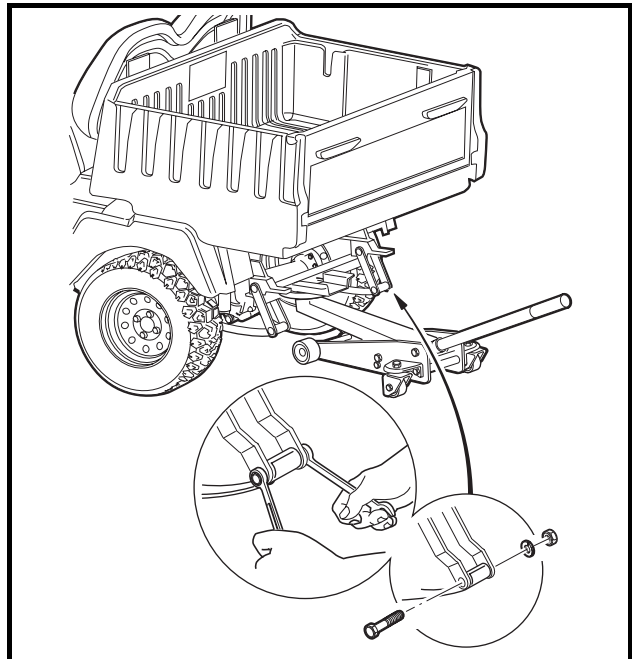

Figure 19-40 Leaf Springs and Shackles

16. Position shocks in the shock mounts and install cushions, mounting washers and nuts (**Figure 19-41, Page 19-16**). Tighten nuts until cushions expand to be the same diameter as the mounting washers.
17. Connect brake cables. **See Brake Cable Installation, Section 6, Page 6-11.**
18. Connect the engine kill switch wire (18-gauge white/black) to the bullet connector at the lower right front of the engine (**Figure 19-42, Page 19-16**).
19. Install three wire ties to secure the engine kill wire to the accelerator cable where they both route together on the passenger side of the engine.

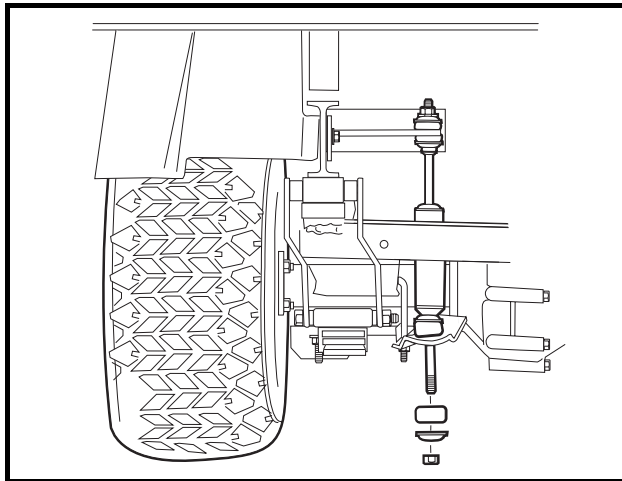

Figure 19-41 Shock Absorber

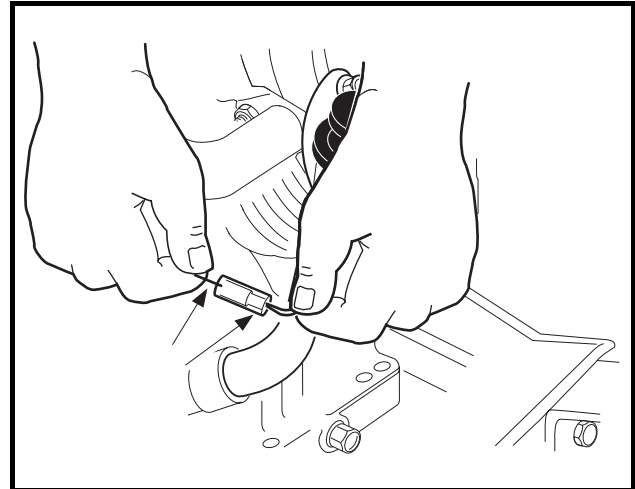

Figure 19-42 Ignition Kill Wire

20. Connect the oil level sensor wire (18-gauge yellow) to the jumper wire (**Figure 19-43, Page 19-16**).
21. Connect the 6-gauge white wire to the F2 post, the 6-gauge black ground wire to the A2 post and tighten both wires to 48 in-lb (5.4 N·m). Connect the 16-gauge yellow wire to the DF post on the starter/generator and tighten to 30 in-lb (3.4 N·m) (**Figure 19-44, Page 19-16**).

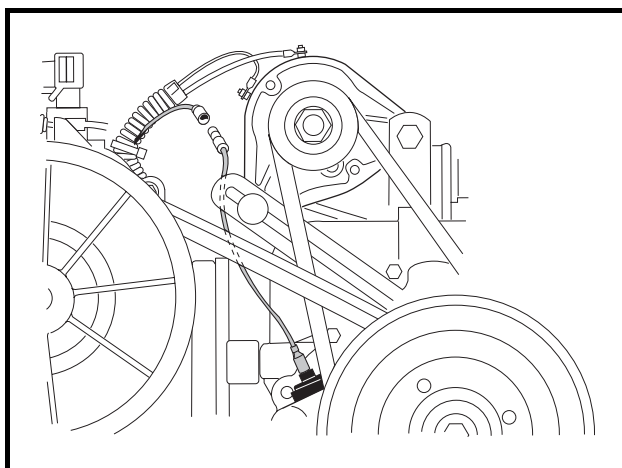

Figure 19-43 Oil Level Sensor Jumper wire

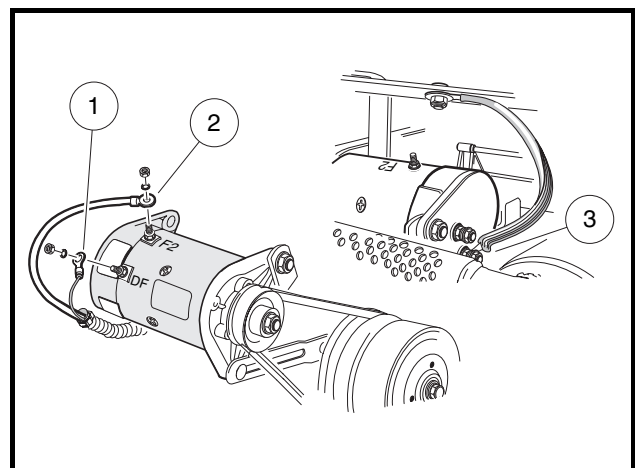

Figure 19-44 Starter/Generator

1. Yellow Wire 2. White Wire 3. Ground Wire at A2 Terminal

22. Position the shifter cable in the shifter cable mounting bracket on the engine and tighten the mounting nuts to 22 ft-lb (29.8 N·m). Connect shifter cable rod end to the shifter arm (**Figure 19-45, Page 19-17**).
23. Attach the ground wire to the mounting screw on the oil filler tube mounting bracket and tighten to 50 in-lb (5.7 N·m) (**Figure 19-46, Page 19-17**).

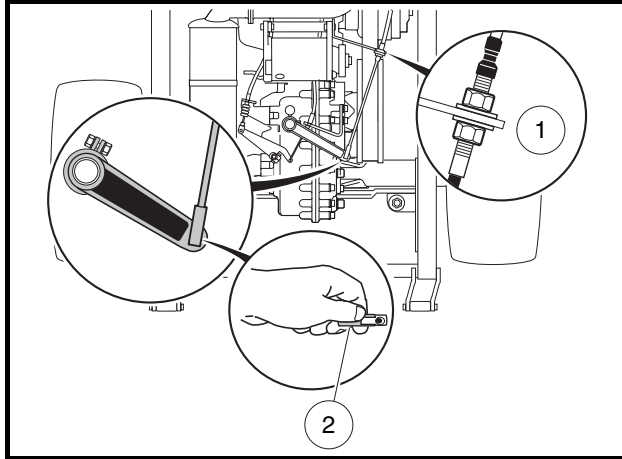

Figure 19-45 Shifter Cable (Top View)

1. Nuts. 2. Pull spring release back to connect shifter cable to lever.

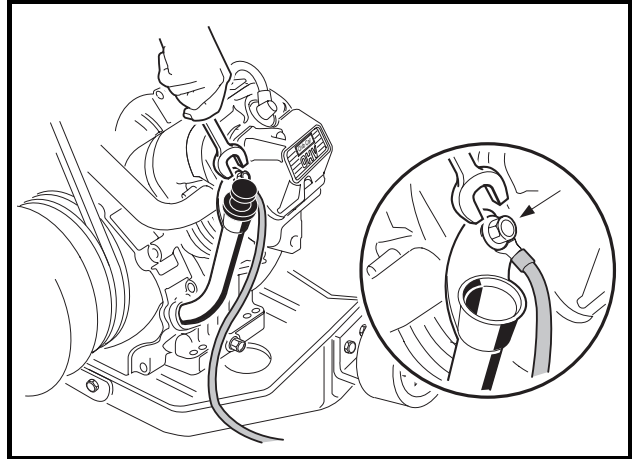

Figure 19-46 Engine Ground and Retaining Nut

24. Connect accelerator cable to actuator cam in the electrical box. Position the accelerator cable in the mounting slot in the wall of the electrical box and tighten mounting nuts to 18 in-lb (2.0 N·m) (**Figure 19-47, Page 19-17**). Install electrical box cover and tighten mounting screw.
25. Remove the 1/4-inch bolt from the fuel line and connect the fuel line to the carburetor and secure with a hose clamp (**Figure 19-48, Page 19-17**).

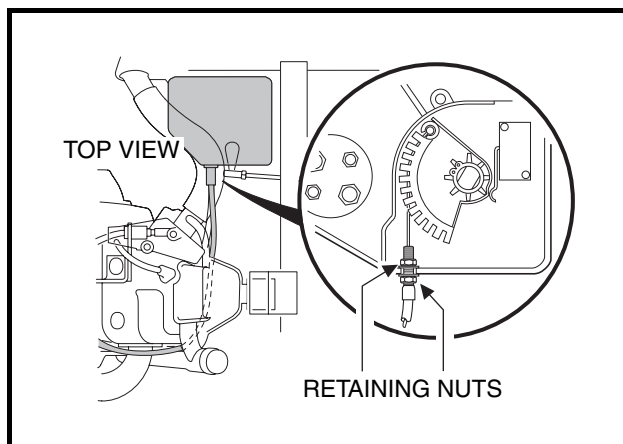

Figure 19-47 Connect Cable to Cam and Secure with Retaining Nuts

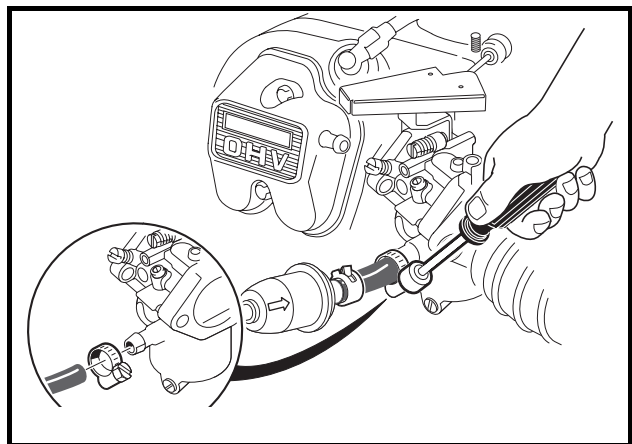

Figure 19-48 Connect Fuel Line

26. Connect the impulse line to the fuel pump and secure it with the hose clamp (**Figure 19-49, Page 19-18**).
27. Connect air intake hose to carburetor and secure hose clamp (**Figure 19-50, Page 19-18**).

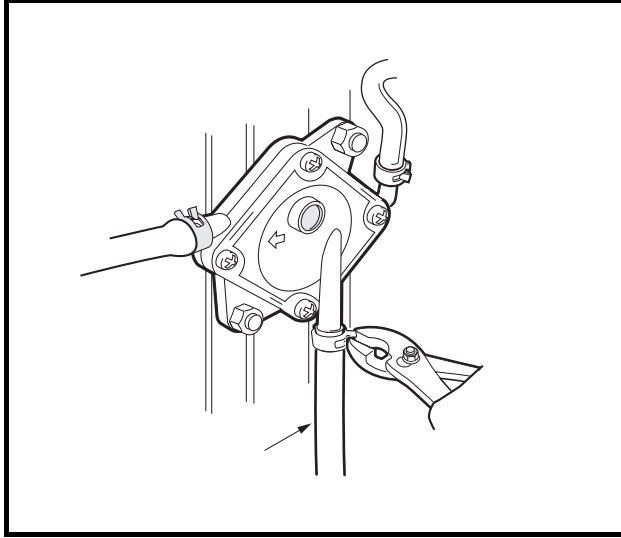

Figure 19-49 Impulse Line

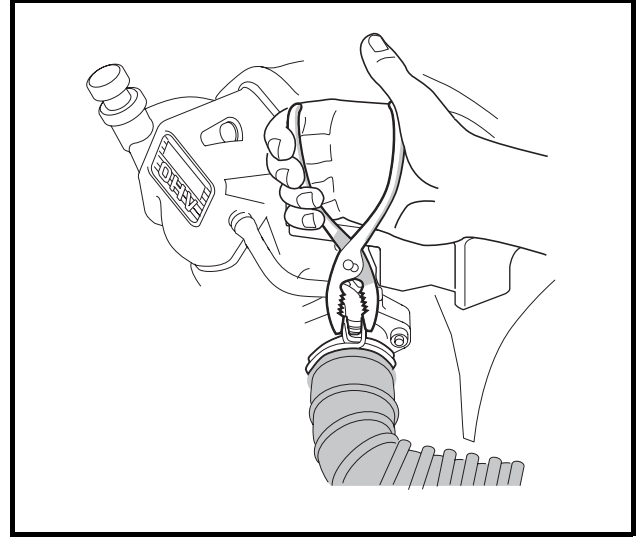

Figure 19-50 Air Intake Hose

28. Connect carburetor vent tube to carburetor and secure with hose clamp (Figure 19-51, Page 19-18).

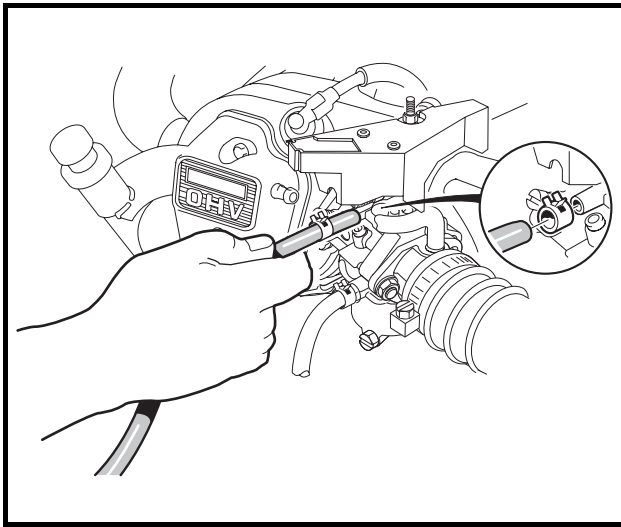

Figure 19-51 Carburetor Tube

29. Install transaxle drain plug and tighten to 21 ft-lb (28.5 N·m).
30. Fill transaxle with 27 oz. (0.8 liter) 80-90 Wt. API class GL-3 or 80-90 WT. AGMA class EP gear lube. Install and tighten the level indicator hole plug to 21 ft-lb (28.5 N·m).
31. Ensure that all wiring is secured properly. **See following WARNING.**

⚠ WARNING

- If wires are removed or replaced make sure wiring and wiring harness is properly routed and secured to vehicle frame. Failure to properly route and secure wiring could result in vehicle malfunction, property damage or personal injury.

32. Connect the spark plug wire.
33. Connect battery cables, positive (+) cable first, and tighten hardware to 144 in-lb (16 N·m) (**Figure 1-1, Page 1-3**). Coat terminals with Battery Terminal Protector Spray (CCI P/N 1014305) to minimize corrosion.
34. Adjust the engine RPM setting. **See Engine RPM Adjustment on page 16-12.**

FORWARD/REVERSE SHIFTER CABLE

See General Warning on page 1-1.

If the Forward/Reverse shifter cable is damaged in any way, it must be replaced.

FORWARD/REVERSE SHIFTER CABLE REMOVAL

NOTE: Before removing cable, note cable routing and positions of wire ties or other devices securing the cable to the vehicle. When installed, cable must be routed and secured as it was originally.

1. Turn the key switch to the OFF position and remove the key. Place the Forward/Reverse handle in the NEUTRAL position and chock the wheels.
2. Disconnect the battery cables as instructed. **See WARNING “To avoid unintentionally starting...” in General Warning on page 1-2.**
3. Remove the cable end socket (1) from the Forward/Reverse shifter assembly stud (2) (**Figure 19-52, Page 19-20**).
4. Depress and push down on tangs (3) anchoring front of cable jacket to chassis bracket.
5. Remove the ball joint socket (4) from the shifter arm ball stud (5) on the transaxle.
6. Loosen the retaining nuts (6) anchoring rear of cable jacket to bracket (7) at starter/generator.
7. If equipped, remove wire tie(s) securing cable jacket to frame rail.
8. Remove cable (8) from the vehicle.

FORWARD/REVERSE SHIFTER CABLE INSTALLATION

1. Begin at the Forward/Reverse shifter, and route the cable (8) exactly as it was originally, to the transaxle shifter lever.
2. Secure rear of cable jacket to bracket (7) at starter/generator with a retaining nut (6) on each side of the bracket (**Figure 19-52, Page 19-20**). Tighten nuts to 22 ft-lb (29.8 N·m).
3. Feed front of cable through the chassis bracket and push the cable jacket anchor up into bracket until tangs (3) snap into place.
4. Install the ball joint socket (4) on the shifter arm ball stud (5) on the transaxle.
5. Install the cable end socket (1) on the Forward/Reverse shifter assembly stud (2) (**Figure 19-52, Page 19-20**).
6. If originally equipped, secure cable jacket to frame rail with wire tie(s).
7. Connect battery cables, positive (+) cable first, and tighten hardware to 144 in-lb (16 N·m) (**Figure 1-1, Page 1-3**). Coat terminals with Battery Terminal Protector Spray (CCI P/N 1014305) to minimize corrosion.

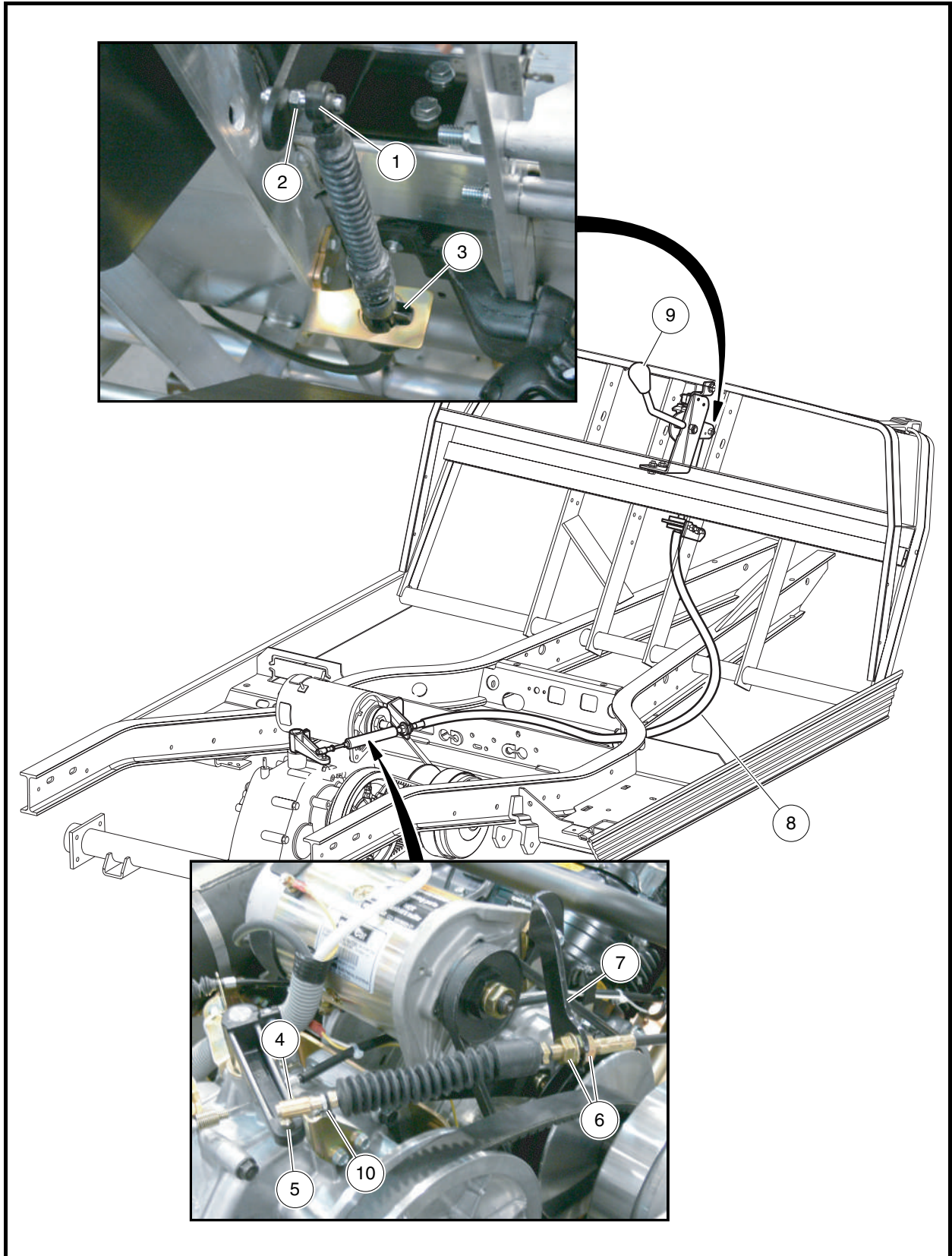

Figure 19-52 Forward/Reverse Shifter Cable

FORWARD/REVERSE SHIFTER CABLE ADJUSTMENT

With the shifter lever of the unitized transaxle in the NEUTRAL position (**Figure 19-53, Page 19-21**), the Forward/Reverse handle (9) (**Figure 19-52, Page 19-20**) should align with the N position on the dash. For minor adjustments, the nut (10) may be loosened and the ball joint socket (4) rotated to get the proper adjustment (**Figure 19-52, Page 19-20**). See following **CAUTION**.

⚠ CAUTION

- Be sure threads of cable are engaged in ball joint socket at least 1/4 inch (6.35 mm). If ball joint socket comes loose from the cable, the Forward/Reverse shifter will not operate properly.

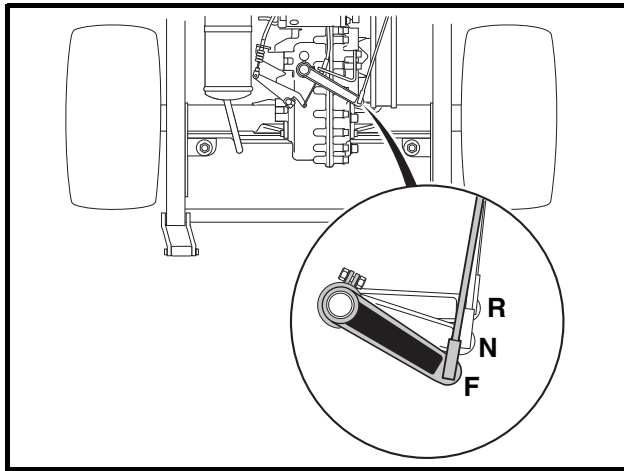

Figure 19-53 Forward/Reverse Shifter Positions

For major adjustments, the cable jacket retaining nuts (6) must be loosened and adjusted. When the cable is properly adjusted, with the Forward/Reverse handle (9) (**Figure 19-52, Page 19-20**) in the NEUTRAL position, the shifter arm of the transaxle will also be in the NEUTRAL position (**Figure 19-53, Page 19-21**). Tighten nuts at the transaxle to 22 ft-lb (29.8 N·m).

SECTION 20 – TORQUE CONVERTER: GASOLINE VEHICLE

▲ DANGER

- See General Warning on page 1-1.

▲ WARNING

- See General Warning on page 1-1.

GENERAL INFORMATION

The torque converter consists of a drive clutch, a driven clutch, and a drive belt. The drive clutch, which is mounted to the engine, is in the open position when the engine is at idle. At this point, the belt is riding at a low position (smaller diameter) on the drive clutch. The driven clutch is mounted on the transaxle. It is in the closed position, and the drive belt is riding at a high position (large diameter) on it when the engine is at idle.

At the point of clutch engagement, the speed ratio of the drive clutch to the driven clutch is 3.5 to 1. This ratio provides excellent starting and low-speed torque.

As engine speed increases, centrifugal force on internal weights close the drive clutch, pushing the belt up to a higher position on the clutch (increasing the diameter of the belt loop). As the diameter of the belt loop increases at the drive clutch, the driven clutch is forced open as the diameter of its belt loop decreases. At governed top speed, the ratio of drive clutch to driven clutch is 0.92 to 1.

On steep grades, or when the vehicle is heavily loaded, higher torques are achieved through the use of a torque-sensing ramp device on the driven clutch. This device overcomes the force of the centrifugal weights to close the driven clutch and open the drive clutch, thus increasing axle torque with little or no change in engine RPM.

The engine and torque converter rotate clockwise as viewed from the clutch side of the engine.

To provide optimum performance for the OHV engine and powertrain, the vehicle uses a pair of tuned clutches.

To properly assemble and disassemble the torque converter, the following tools should be used:

- Torque Converter Tool Kit (CCI P/N 1014510) (**Figure 20-1, Page 20-2**).
- Scribe or small pick (not included in torque converter tool kit).

TROUBLESHOOTING

See General Warning on page 1-1.

Maintaining proper adjustment of the engine and governor, as well as the torque converter, is essential to the troubleshooting process. If these adjustments are within specifications and, when climbing a steep hill, the engine begins to lose RPM before the drive belt reaches the top of the driven clutch, there is a torque converter problem.

If the torque converter is not operating properly:

1. Check the governor and throttle settings. **See Governor Cable on page 16-9.**

2. Inspect the driven clutch for dirt and dust buildup on its component parts. Clean the driven clutch with water to remove any dust or dirt, then drive the vehicle and check for proper operation.
3. If cleaning the driven clutch does not solve the problem, disassemble and thoroughly clean all parts of the drive clutch. Be sure to clean the plastic drive buttons (10) (**Figure 20-5, Page 20-6**).

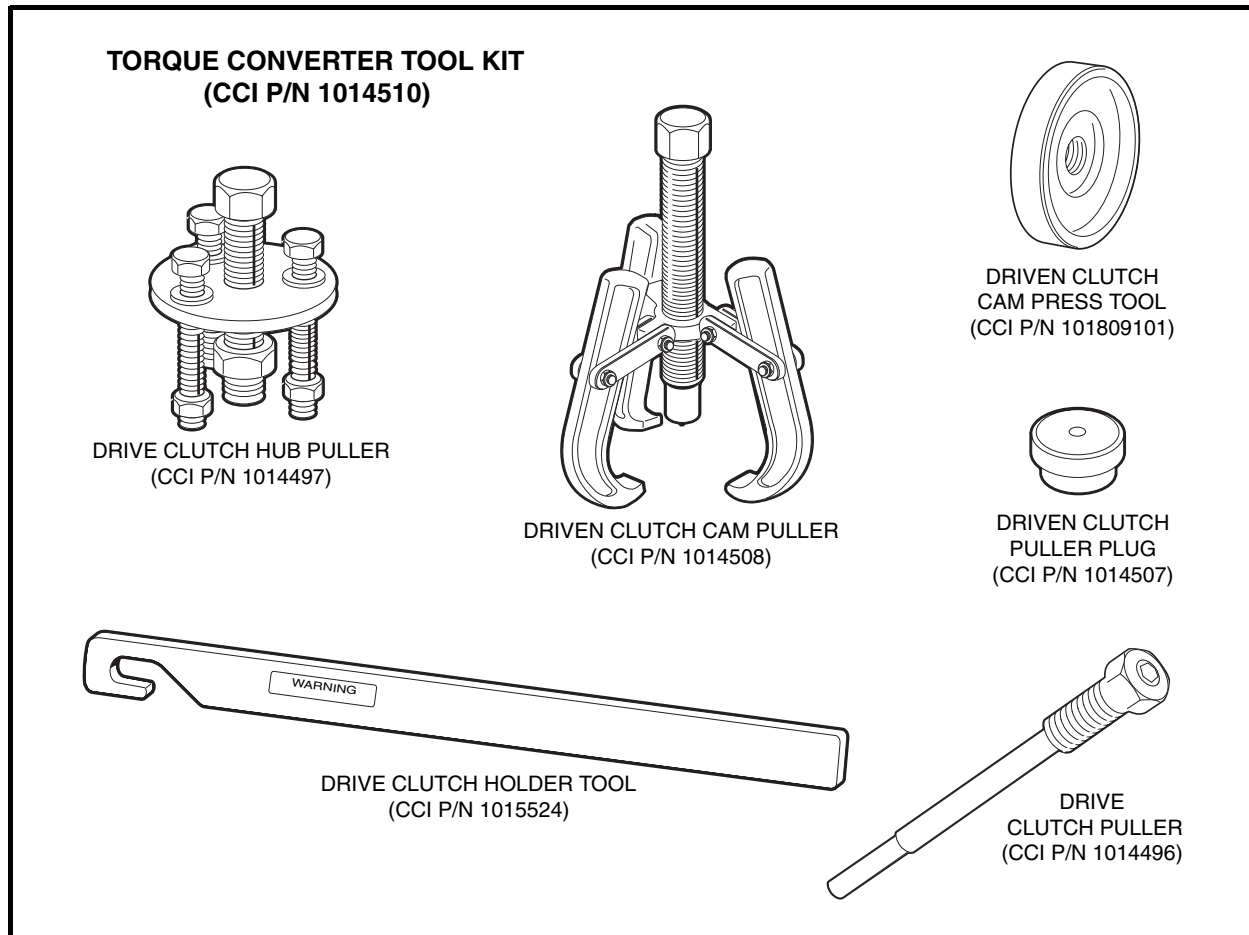

Figure 20-1 Torque Converter Tool Kit

DRIVE BELT

See General Warning on page 1-1.

The drive belt should be inspected semiannually for wear and (or) glazing. If it is excessively worn, frayed, or glazed, replace the belt.

As the drive belt wears, the engine RPM will increase to compensate for the change in torque converter ratio. This will keep the vehicle's maximum ground speed correct. **See Section 2 – Vehicle Specifications.**

DRIVE BELT REMOVAL

1. Disconnect the battery cables as instructed. **See WARNING “To avoid unintentionally starting...” in General Warning on page 1-2.**

2. Disconnect the spark plug wire from the spark plug. See **WARNING** “To avoid unintentionally starting...” in **General Warning** on page 1-2.
3. Grasp the belt midway between the drive and driven clutches. Lift upward on the belt to force the sheaves of the DRIVEN clutch apart, then roll the belt off the DRIVEN clutch by rotating the clutch counterclockwise (**Figure 20-2, Page 20-3**). See following **CAUTION**.

⚠ CAUTION

- **Make sure fingers are not underneath the belt when rolling the belt off the driven clutch.**

4. Remove the belt from the drive clutch.

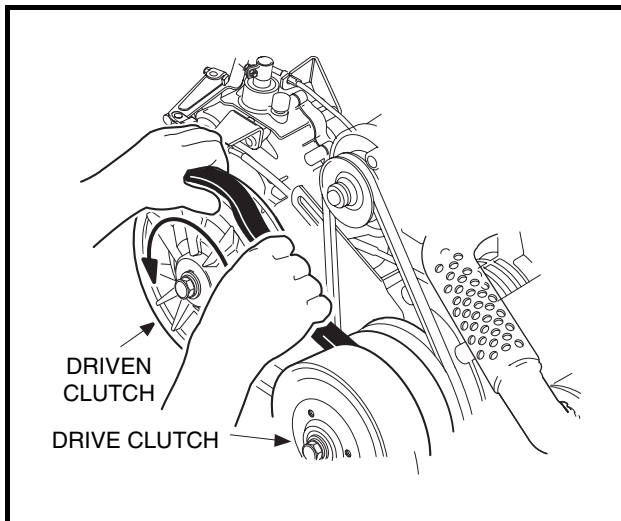

Figure 20-2 Drive Belt Removal

DRIVE BELT INSTALLATION

1. Position the new belt on the drive clutch, then start the belt over the top of the driven clutch.
2. With the belt started onto the driven clutch, rotate the driven clutch counterclockwise and roll the belt over the driven clutch sheaves and onto the clutch.
3. Connect battery cables, positive (+) cable first, and tighten hardware to 144 in-lb (16 N·m). See **Figure 1-1, Page 1-3**. Coat terminals with Battery Terminal Protector Spray (CCI P/N 1014305) to minimize corrosion.
4. Connect the spark plug wire to the plug.

DRIVE CLUTCH

See General Warning on page 1-1.

⚠ CAUTION

- Be very careful when handling the clutches. A clutch that has been dropped will not be properly balanced. If either clutch is dropped, assume that it is damaged and replace it.

DRIVE CLUTCH REMOVAL

1. Remove the drive belt as instructed. See **Drive Belt Removal** on page 20-2.
2. Loosen the starter/generator mounting and adjusting hardware and then remove the starter belt. See **WARNING “Moving parts! Do not...”** in General Warning, Section 1, Page 1-1.

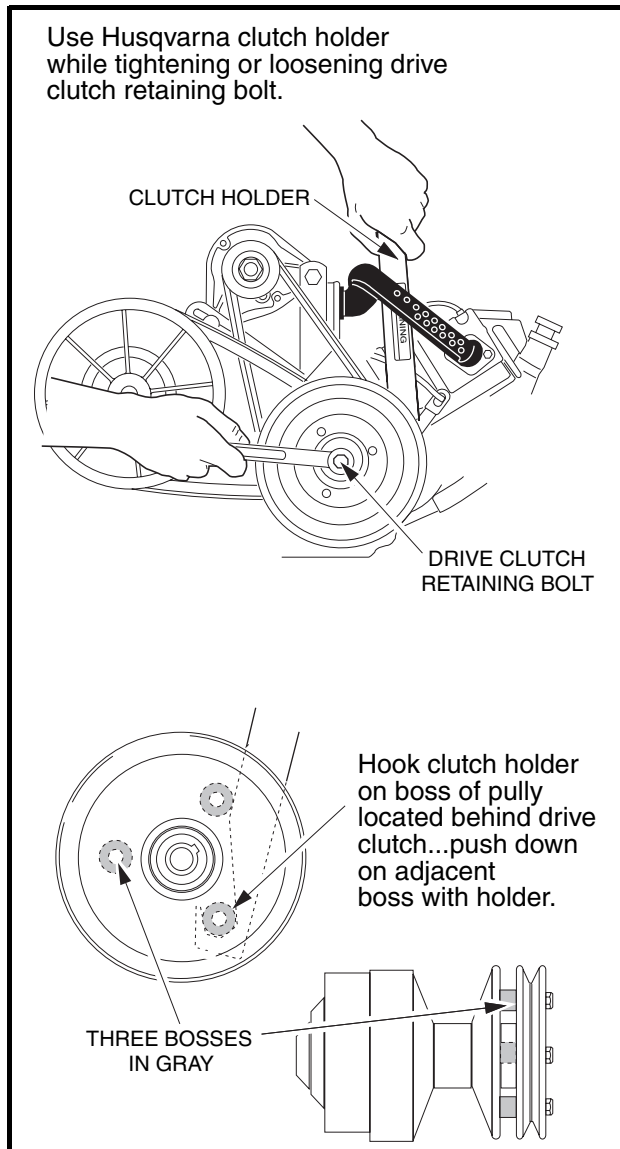

Figure 20-3 Loosen Retaining Bolt

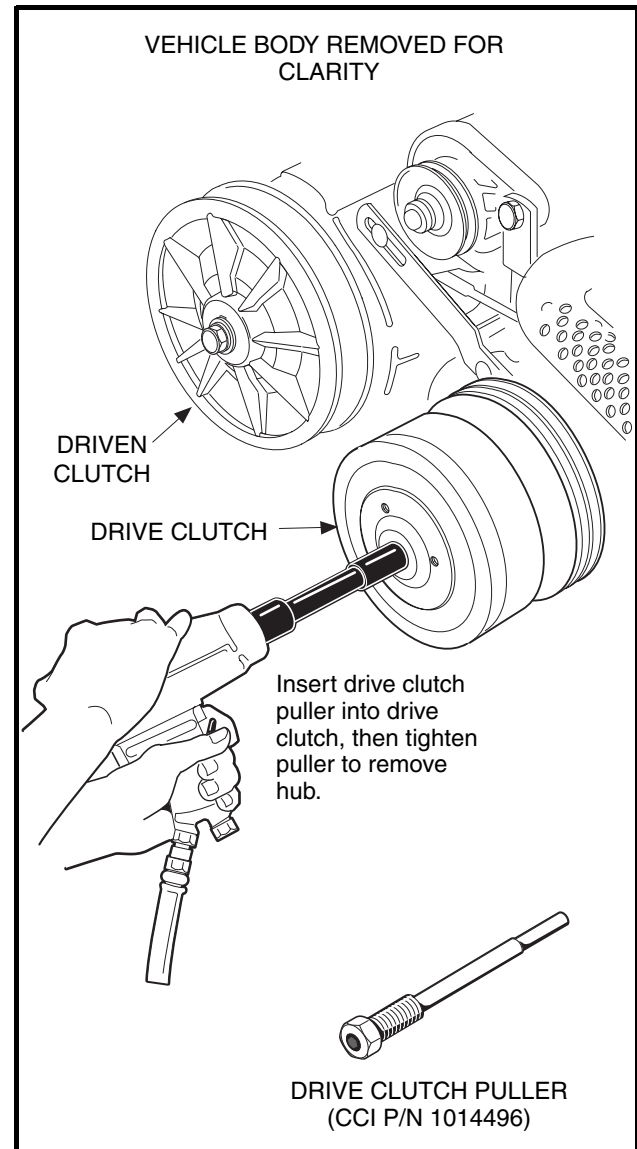

Figure 20-4 Drive Clutch Removal

3. Place chocks at the front wheels and lift the rear of the vehicle with a chain hoist or floor jack. Place jack stands under the axle tubes to support the vehicle. This will allow the weight of the centerline of the drive clutch to drop below the frame I-beam for access to the bolt securing the drive clutch. **See following WARNING.**

⚠ WARNING

- **Lift only one end of the vehicle at a time. Use a suitable lifting device (chain hoist or hydraulic floor jack) with 1000 lb. (454 kg) minimum lifting capacity. Do not use lifting device to hold vehicle in raised position. Use approved jack stands of proper weight capacity to support the vehicle and chock the wheels that remain on the floor. When not performing a test or service procedure that requires movement of the wheels, lock the brakes.**
4. Remove the drive clutch retaining bolt (17) and mounting washer (19) (**Figure 20-5, Page 20-6**) **See also Figure 20-3, Page 20-4. See following NOTE.**

NOTE: *The drive clutch mounting bolt has left-hand threads.*

The crankshaft has left-hand threads at the clutch mounting hole.

5. Lubricate the threaded portion of the clutch puller tool with a light oil and thread the clutch puller tool into the clutch retaining bolt hole.
6. Use a 1/2-inch drive air wrench to tighten the clutch puller tool. The drive clutch will come free of the crankshaft (**Figure 20-4, Page 20-4**).
7. Support the drive clutch assembly in your hand and back the clutch puller tool out of the crankshaft.

⚠ CAUTION

- **Do not hit or tap the clutch with a hammer. Do not pry the clutch. These actions will damage the clutch.**

DRIVE CLUTCH CLEANING AND INSPECTION

1. Use a dry, lint-free cloth to clean clutch parts.

⚠ CAUTION

- **Do not lubricate the drive clutch. Lubricants attract dirt and dust, which interfere with proper clutch operation.**
 - **Use only a dry cloth to lightly wipe the shaft of the fixed face assembly (7) (Figure 20-5, Page 20-6). Do not use a brush or steel wool. These will damage the surface of the shaft.**
 - **Do not use solvents. Solvents will damage the lubricating characteristics of the bushings.**
2. Inspect the belt contact surfaces of the clutch sheaves for wear. If any area of a sheave contact surface has wear of 0.060 inch (1.52 mm) or more, the clutch should be replaced.

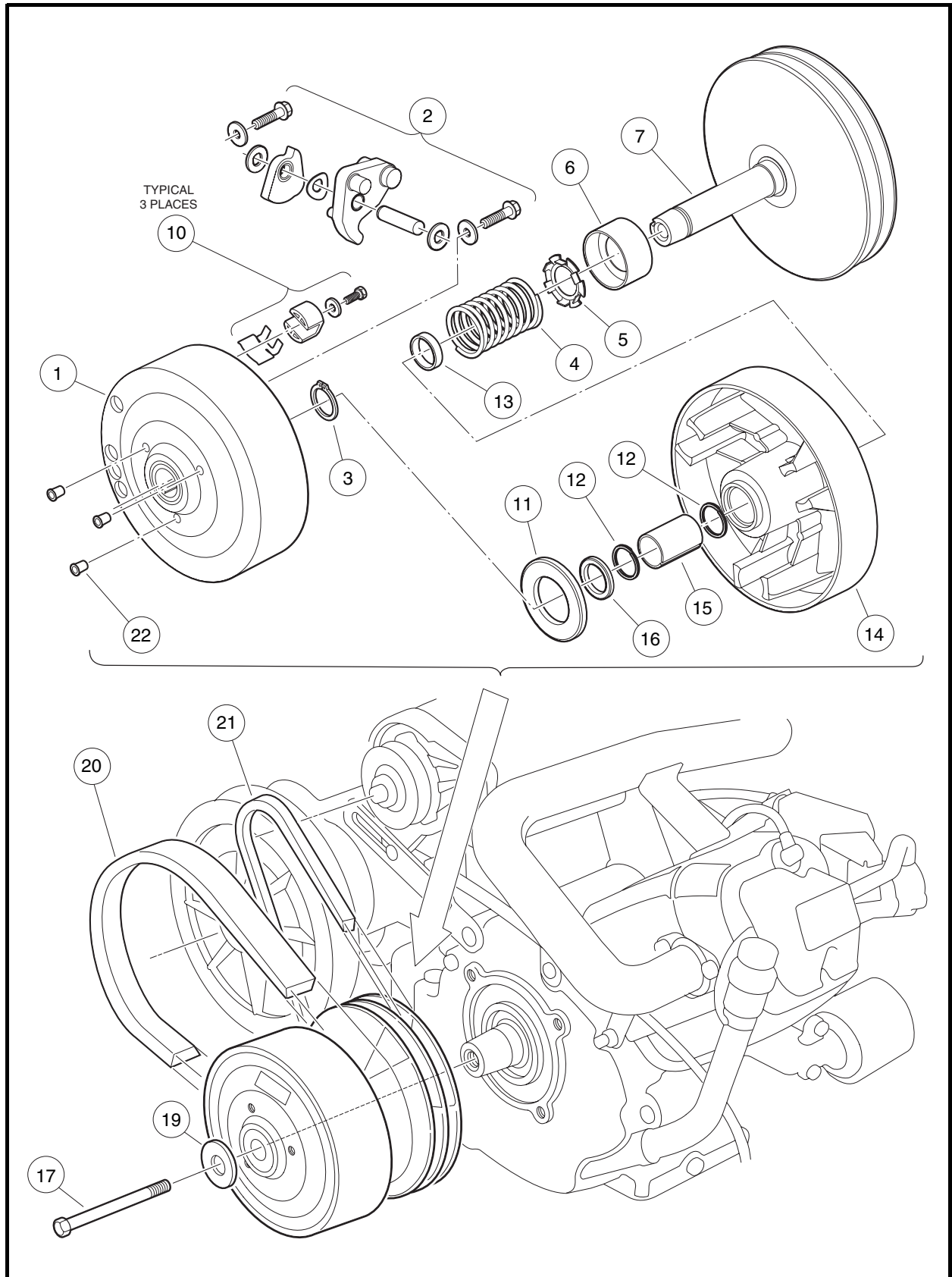

Figure 20-5 Drive Clutch Assembly

DRIVE CLUTCH DISASSEMBLY

⚠ CAUTION

- The drive clutch is balanced as an assembly. Before disassembly, make match marks on the drive clutch hub and on the moveable face assembly so they can be reassembled in the same positions (Figure 20-6, Page 20-7).

1. Make match marks on the drive clutch hub and on the moveable face casting (Figure 20-6, Page 20-7).
2. Remove the drive clutch hub (1) (Figure 20-5, Page 20-6):
 - 2.1. Remove the three plugs (22) from the clutch puller attachment holes (Figure 20-5, Page 20-6).
 - 2.2. Thread the center bolt of the Drive Clutch Hub Puller (CCI P/N 1014497) into clutch until the stop nut touches the clutch, then back the bolt out one-half turn (Figure 20-7, Page 20-7).
 - 2.3. Thread the three small bolts of the puller into corresponding holes in the clutch. Tighten bolts evenly, making sure the face of the puller plate is parallel to the face of the clutch (Figure 20-7, Page 20-7).
 - 2.4. Unscrew the puller center bolt out of the clutch to pull drive clutch hub off.

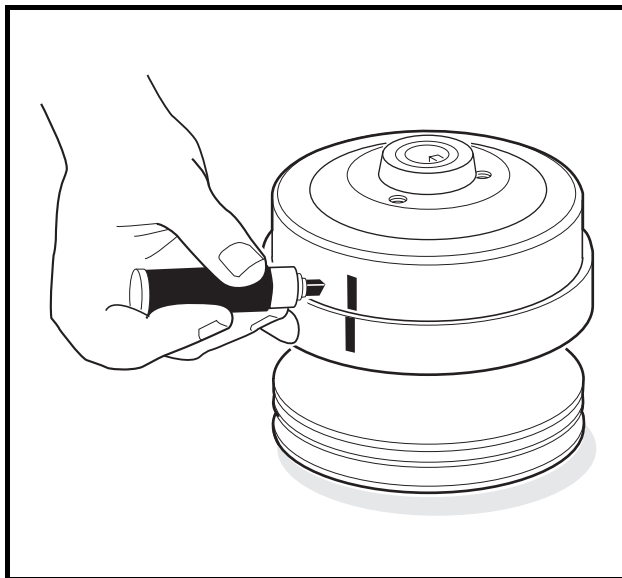

Figure 20-6 Mark Drive Clutch Hub

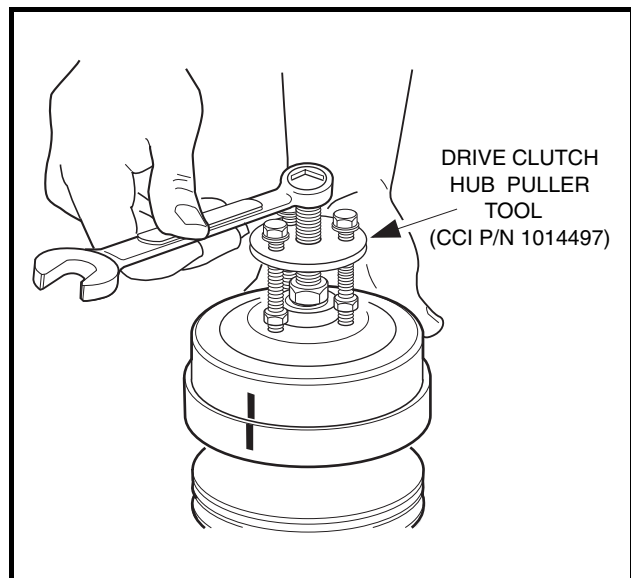

Figure 20-7 Remove Drive Clutch Hub

3. Remove the thrust washer (11) from the moveable face (14) (Figure 20-5, Page 20-6).
4. Remove the drive buttons (Figure 20-8, Page 20-8).
 - 4.1. Remove the screws, flat washers, drive button take-up springs, and drive buttons as shown (Figure 20-8, Page 20-8).

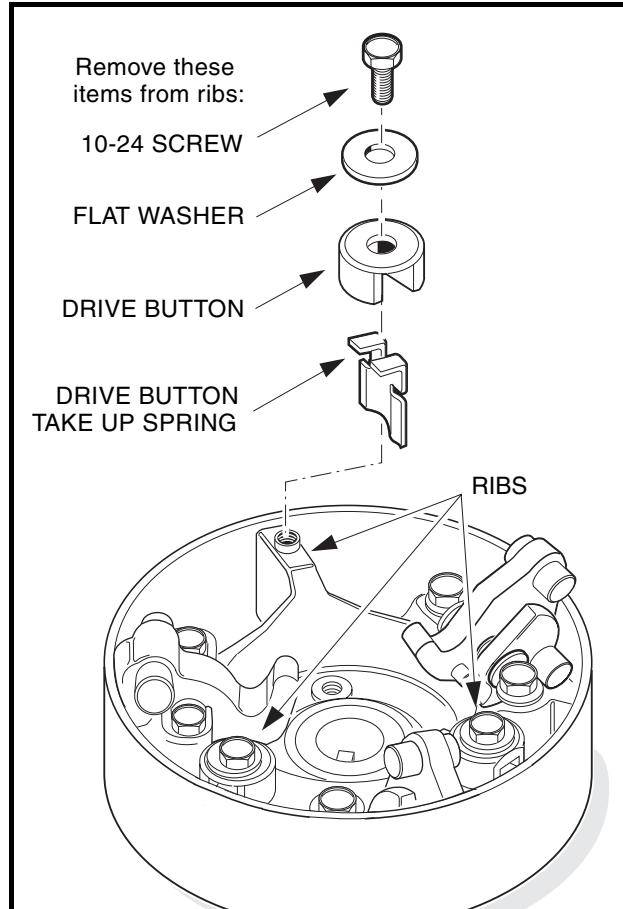

Figure 20-8 Drive Button Mounting

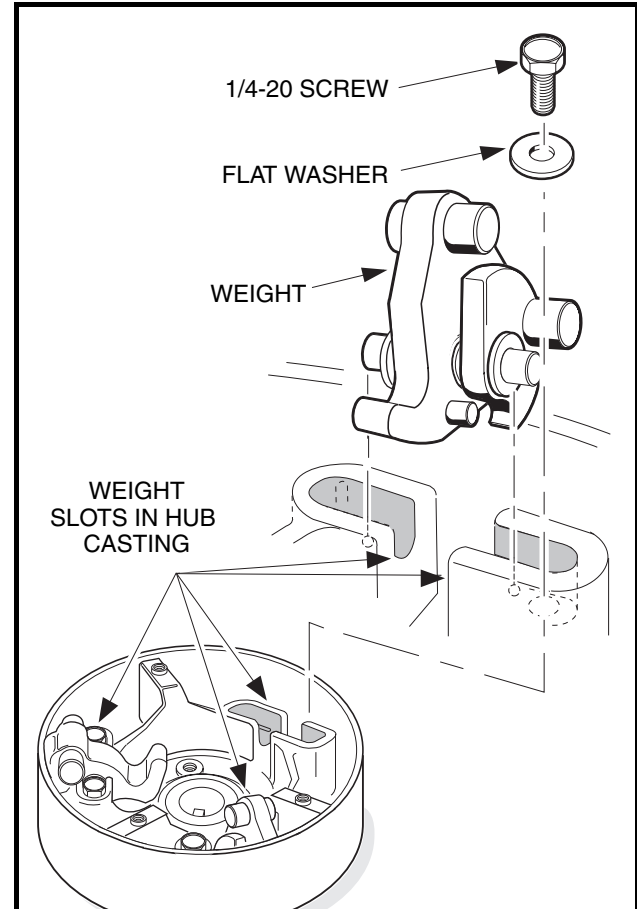

Figure 20-9 Weight Position

5. Remove the clutch weights (Figure 20-9, Page 20-8):

- 5.1. Remove the screws and flat washers attaching the weights as shown (Figure 20-9, Page 20-8).
- 5.2. Pull the weight assemblies, with pins, from the clutch.
- 5.3. Before removing, note the orientations of the wave washer and of the primary and secondary weights to one another (Figures 20-10 and 20-11, Page 20-8). Remove the plastic washers, weights and wave washer from the pin. Retain all parts.

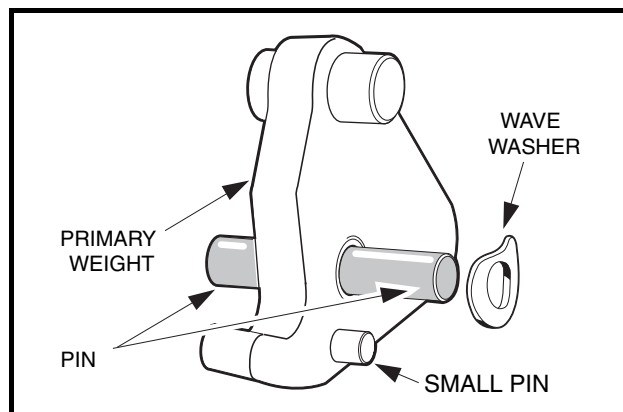

Figure 20-10 Install Pin and Washer

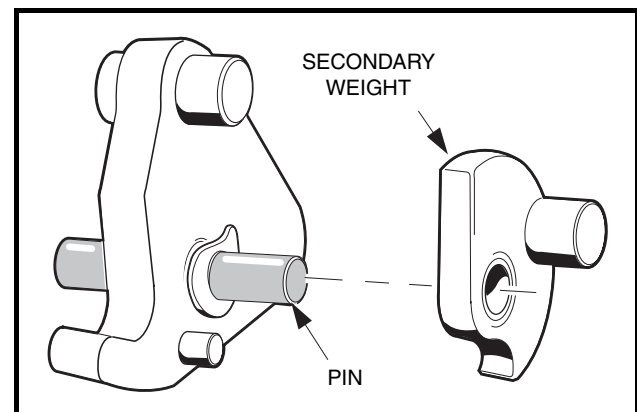

Figure 20-11 Install Secondary Weight

- Remove the retaining ring (3) from the shaft of the fixed face assembly (7) and slide the moveable face (14) off the shaft (**Figure 20-5, Page 20-6**). See following **NOTE**.

NOTE: If the moveable face is removed from the hub of the fixed face, the spiral back-up rings (12) must be replaced with new ones (**Figure 20-5, Page 20-6**).

- Remove the spacer (16), and spring (4) and retainer (5). The spring retainer can be removed from the spring if necessary (**Figure 20-5, Page 20-6**).

- If necessary, remove idler bearing. Use a press to remove the bearing (**Figure 20-12, Page 20-9**). See following **NOTE**.

NOTE: Do not remove the idler bearing unless it needs to be replaced. If idler bearing is removed, replace it with a new bearing.

- Use a scribe or small pick to remove the spiral backup rings (12) from each end of the bore in the fixed face assembly (**Figure 20-5, Page 20-6**). See also **Figure 20-13, Page 20-9**. Discard the rings.

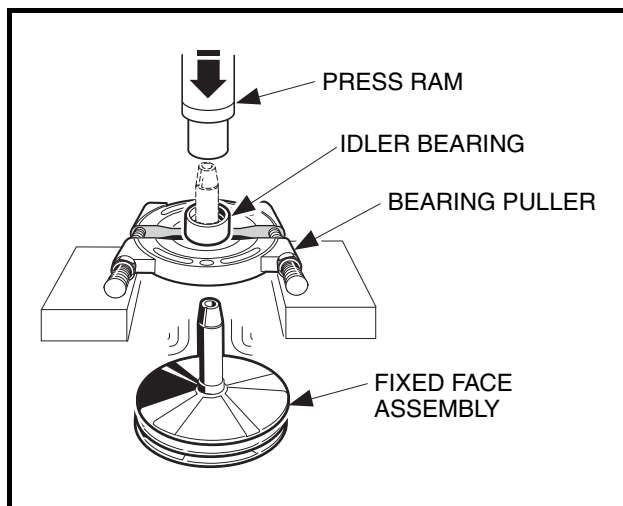

Figure 20-12 Remove Idler Bearing

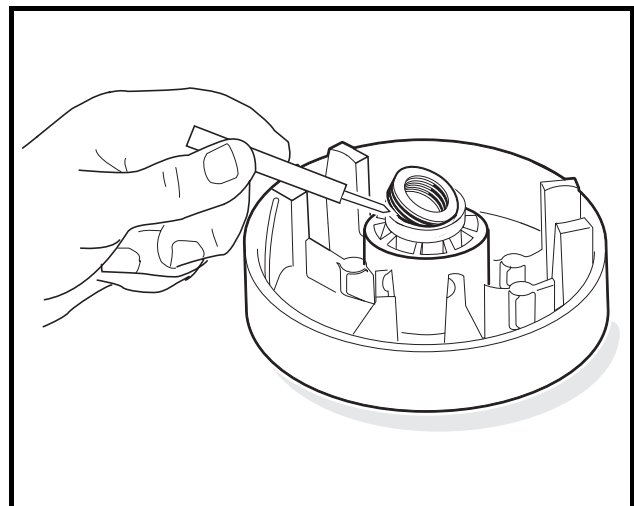

Figure 20-13 Spiral Back-up Rings

INSPECTION OF DRIVE CLUTCH PARTS

- Inspect the idler bearing (6) for smooth rotation or seal damage (**Figure 20-5, Page 20-6**). See following **NOTE**.

NOTE: It is normal for a small amount of grease to be present at the edge of seal.

- Inspect the bore of the moveable face assembly (14) for scarring or wear. The moveable face assembly must be replaced if the bore is worn to a diameter of 0.883 inch (22.4 mm) or larger (**Figure 20-5, Page 20-6**).
- Inspect the steel shaft (7) on the fixed face assembly. There should be no measurable wear anywhere on the shaft. Replace the shaft if it is worn, scratched, or damaged.
- Inspect the thrust washer (11) for wear. If it is worn more than 0.030 inch (0.76 mm), turn it over or replace it with a new one.
- Inspect the primary weights (2) and the hub casting for wear. If the primary weights show signs they are touching the casting, the tips of the weights have worn beyond specification and they must be replaced.

6. Inspect the pins on the primary weights (2). There should be no measurable wear. Replace them if they are worn, scratched, or damaged.
7. Inspect the drive belt pulley sheaves for excessive wear or damage. If the sheaves are excessively worn or damaged, replace the entire fixed face drive assembly.

DRIVE CLUTCH ASSEMBLY

1. Press idler bearing (6) onto the shaft of the fixed face assembly (7). Press on the inner race of the bearing only. Make sure that the cup side of bearing is facing away from the fixed face (**Figure 20-5, Page 20-6**).
2. Using needle nose pliers, install the spring retainer (5) onto the spring (4).
3. Install the spring (4) and retainer (5) into the cup of the idler bearing (6).
4. Install the spacer (13) onto the shaft of the fixed face.
5. Install a new spiral backup ring (12) in each end of the bore of the moveable face assembly (14).
6. Install the moveable face assembly (14) onto the shaft of the fixed face assembly (7).

⚠ CAUTION

- **To avoid damaging the spiral back-up rings, be very careful when installing the moveable face.**

- 6.1. Rotate the moveable face assembly clockwise while installing it onto the shaft.
- 6.2. Install the retaining ring (3) (**Figure 20-5, Page 20-6**).
7. Install the primary weights on the mounting pins (**Figure 20-10, Page 20-8**).
8. Install a wave washer on each mounting pin. Make sure that the concave side of the washer faces the side of the primary weight with the small guide pin protruding from it (**Figure 20-10, Page 20-8**).
9. Install the secondary weights onto the mounting pins with the weight pins on the secondary weights pointing away from the primary weights. The wave washers should be between the primary and secondary weights (**Figure 20-11, Page 20-8**).
10. Install white plastic flat washers on each end of the mounting pin and push them against the outside surfaces of the weights. Center the weights and washers on the mounting pin (**Figure 20-14, Page 20-10**).
11. Install the weight assemblies into the slots in the hub casting (**Figure 20-9, Page 20-8**). Make sure the mounting pin protrudes an equal amount on each side of the weights when the assemblies are in position (**Figure 20-14, Page 20-10**).

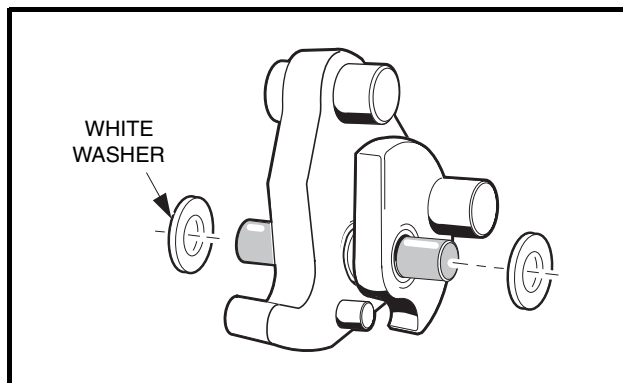

Figure 20-14 Install White Washers

12. Install the 1/4-20 bolts and washers (2) and tighten them to 10 ft-lb (13 N·m) (**Figure 20-5, Page 20-6**).
See following NOTE.

NOTE: Make sure there is at least a (minimum) gap of 0.020 inch (0.51 mm) between each end of the mounting pin and the mounting bolt.

13. Install three drive button take-up springs.
 - 13.1. Install each spring on right-hand side of the three button mounting posts (when looking into the interior of the clutch drive hub, and with the rib at a twelve o'clock position) as shown (**Figure 20-15, Page 20-11**).
14. Compress each take-up spring and install the drive button over the rib and take-up spring (**Figure 20-8, Page 20-8**).
15. Install a no. 10-24 button retaining screw with flat washer through each button and into the rib. Tighten the screws to 34 in-lb (3.8 N·m) (**Figure 20-9, Page 20-8**).
16. Install the thrust washer (11) onto the moveable face assembly (**Figure 20-5, Page 20-6**).
17. Install the hub assembly (8) on the moveable face assembly and align the match marks made before disassembling the clutch. Press the hub assembly on by hand.
18. Replace the three plastic plugs (22) into the hole protectors (**Figure 20-5, Page 20-6**).

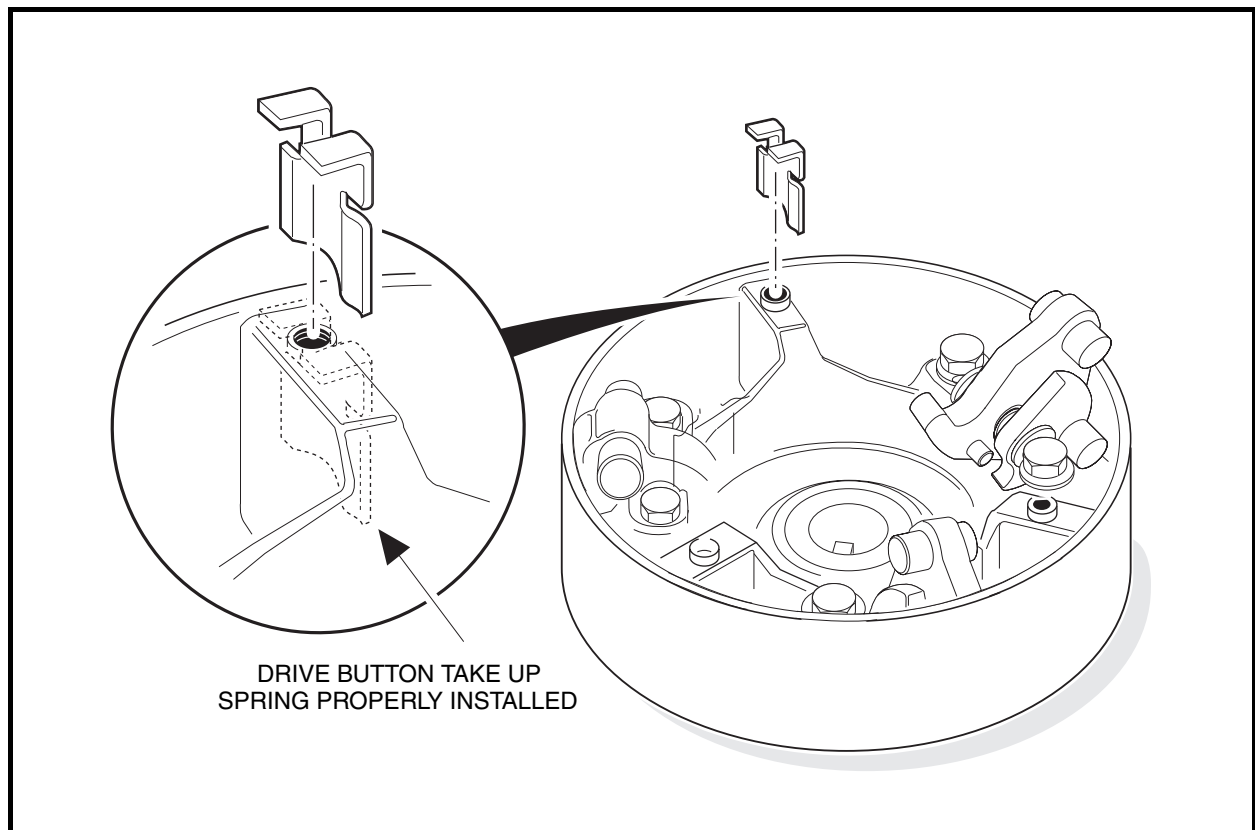

Figure 20-15 Correct Orientation of Drive Button Take-up Springs

DRIVE CLUTCH INSTALLATION

1. Place the drive clutch assembly on the crankshaft taper. Position the mounting washer (19) on the bolt (17) and start the bolt into the crankshaft (**Figure 20-5, Page 20-6**). See following **NOTE**.

NOTE: The drive clutch retaining bolt has left-hand threads. The manufacturer recommends replacing the drive clutch retaining bolt (CCI PN 103345701) when installing the drive clutch. If a new bolt is not available, clean the threads of the original bolt and apply Loctite® 242 to the threaded end prior to installation.

2. Tighten the drive clutch retaining bolt (17) to 25 ft-lb (33.9 N·m) (**Figure 20-5, Page 20-6**).
3. Install the starter/generator belt and adjust belt tension as instructed. See **Belt Tension Adjustment, Section 13, Page 13-10**. Tighten the starter/generator mounting hardware to 23 ft-lb (31.2 N·m) and the adjusting hardware to 13 ft-lb (17.6 N·m).
4. Install the drive belt as instructed. See **Drive Belt Installation on page 20-3**.
5. Connect battery cables, positive (+) cable first, and tighten hardware to 144 in-lb (16 N·m). See **Figure 1-1, Page 1-3**. Coat terminals with Battery Terminal Protector Spray (CCI P/N 1014305) to minimize corrosion.
6. Connect the spark plug wire to the plug.
7. Drive the vehicle and check for proper operation.

DRIVEN CLUTCH

See General Warning on page 1-1.

DRIVEN CLUTCH REMOVAL

1. Remove the drive belt as instructed. See **Drive Belt Removal on page 20-2**.
2. Remove the bolt (11) and mounting washer (12) from the clutch shaft (**Figure 20-18, Page 20-14**).
3. Grasp the driven clutch assembly and slide it off the shaft.
4. Leave the key (9) in the keyway.

DRIVEN CLUTCH DISASSEMBLY

1. Using external snap ring pliers, remove the retaining ring (4) (**Figure 20-16, Page 20-13**). See following **WARNING**.

⚠ WARNING

- Do not place fingers under the cam when removing the cam. The moveable face may spin when the cam buttons release from the cam ramps, resulting in severe personal injury.
2. Insert a puller plug (CCI P/N 1014507) (**Figure 20-17, Page 20-13**) into the shaft bore and use a driven clutch cam puller (CCI P/N 1014508) to remove the cam (4) from the fixed face shaft (8) (**Figure 20-18, Page 20-14**).
 3. Remove the spring (5) (**Figure 20-18, Page 20-14**).
 4. Retain the key (3).
 5. Slide the moveable face (7) off the fixed face shaft (8).

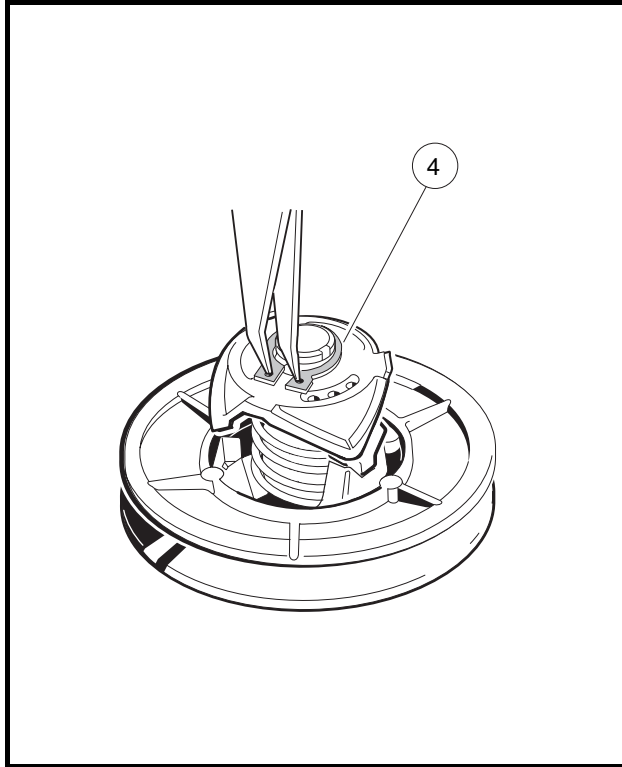

Figure 20-16 Remove Retaining Ring

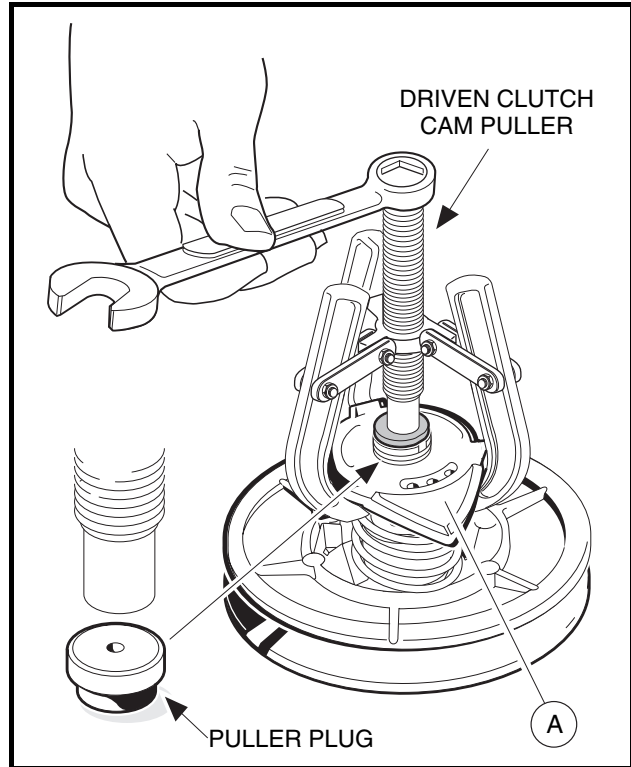

Figure 20-17 Driven Clutch Disassembly

DRIVEN CLUTCH INSPECTION

1. Inspect the cam (4) for excessive wear. Replace it if necessary (Figure 20-18, Page 20-14).
2. Inspect the drive buttons (6) for excessive wear. Replace if necessary. To remove the drive buttons, remove the socket-head cap screws and then the buttons.
3. Inspect the smooth surface on the fixed and moveable face assemblies. Assemblies must be replaced if surfaces are worn more than 0.060 inch (1.5 mm).
4. Inspect the bronze bearing in the moveable face. If the bearing bore diameter is more than 1.384 inch (35.15 mm), the entire moveable face assembly must be replaced.
5. Inspect the shaft of the fixed face assembly. There should be no noticeable wear. Replace the shaft if it is worn, scratched or damaged.

DRIVEN CLUTCH ASSEMBLY

1. Place the three drive buttons (6) in position. Apply one drop of Loctite® 222 to each of the socket-head cap screws and then install and tighten them to 8 in-lb (0.9 N·m) (Figure 20-18, Page 20-14).
2. Slide the moveable face assembly (7) onto the fixed face shaft (8).
3. Place the end of the spring (5) into the hole in the moveable face assembly.
4. Install the key (3) into the keyway of the fixed face assembly (8) shaft.

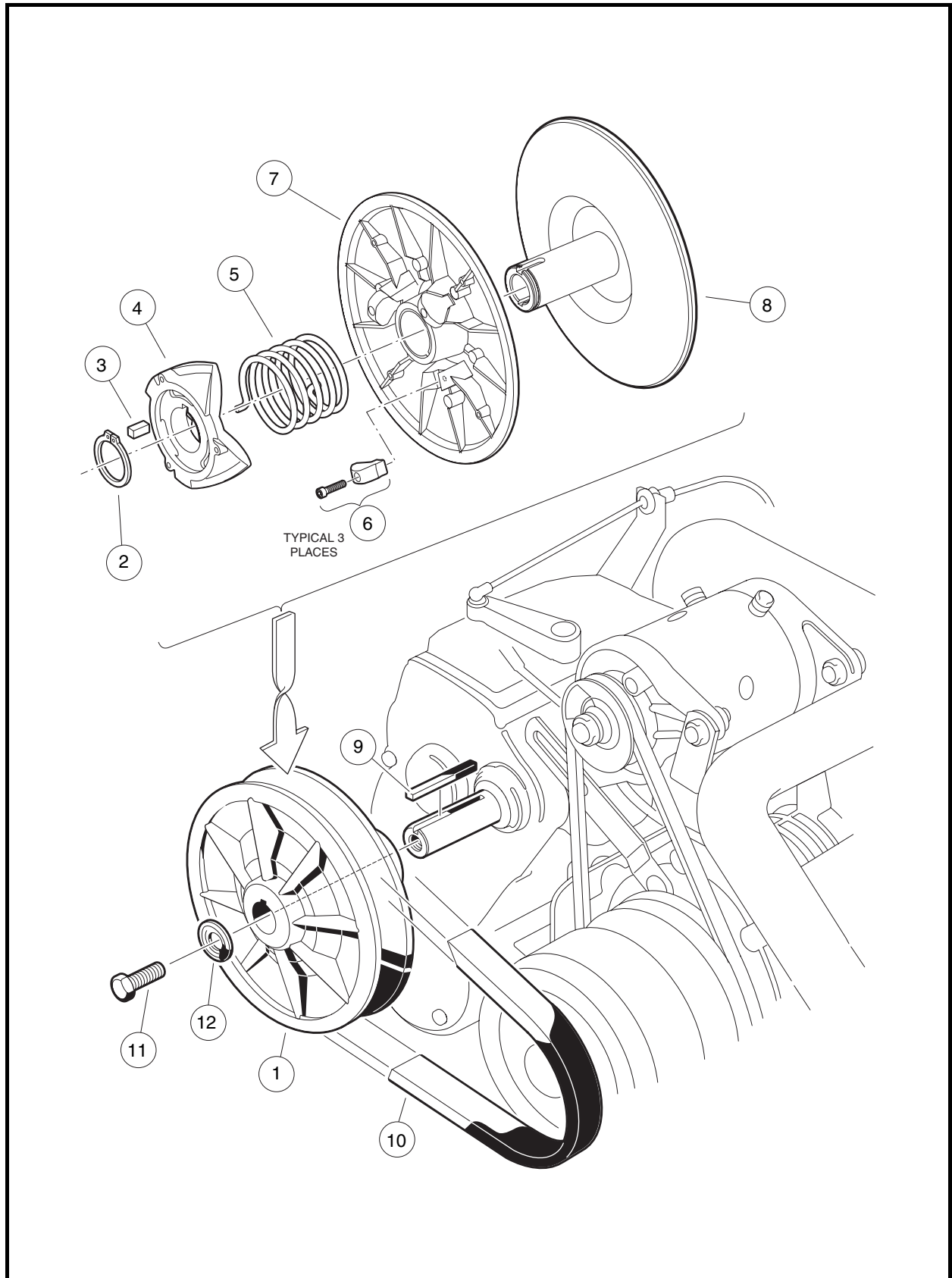
**Figure 20-18 Driven Clutch Assembly**

5. Holding the cam (4) in position for assembly on the shaft, install the other end of the spring (5) into the center spring hole of the cam. Rotate the cam until the keyway is aligned with the key (3) on the fixed face assembly, and then start the cam onto the shaft approximately 1/4 to 3/8 inch (6.3 to 9.5 mm).

5.1. Press Assembly Process:

- 5.1.1. Place the clutch assembly in a press and position the cam press tool (CCI P/N 101809101) on the cam as shown (**Figure 20-19, Page 20-15**).
- 5.1.2. Hold the fixed face assembly (3) and rotate the moveable face assembly (1) one-third turn **clockwise**, then press the cam (2) onto the fixed face assembly (**Figure 20-19, Page 20-15**).
- 5.1.3. Install the retaining ring (2) (**Figure 20-18, Page 20-14**). See following **NOTE**.

NOTE: The retaining ring can be reused if the O.D. does not exceed 1.607 inches (40.82 mm); otherwise, it must be replaced with a new ring (CCI P/N 1014080).

- 5.1.4. While holding onto the cam, tap the end of the fixed face shaft lightly with a plastic mallet until the cam seats against the retaining ring. See following **CAUTION**.

▲ CAUTION

- Do not use a metal hammer to tap the fixed face hub. A metal hammer will damage the shaft.

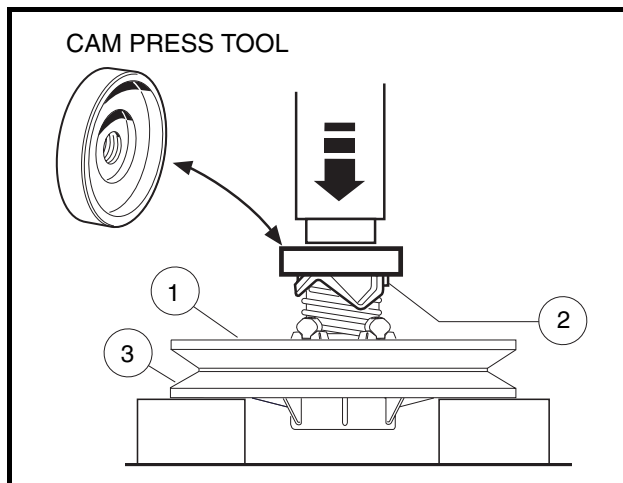

Figure 20-19 Cam Press Tool

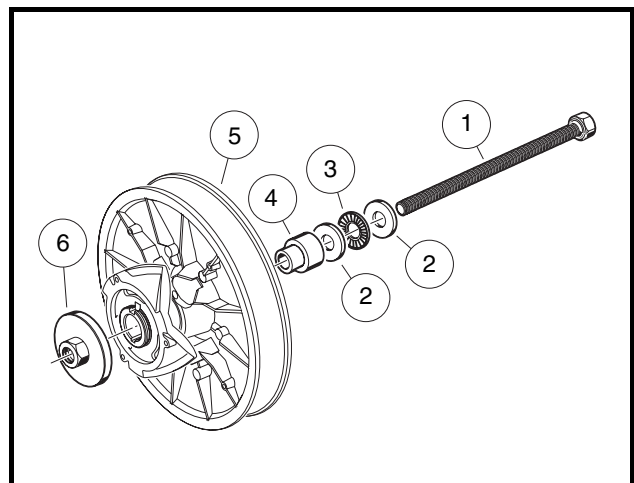

Figure 20-20 Cam Installation Tool

5.2. Field Assembly Process:

NOTE: This process is for field assembly requirements where hydraulic and pneumatic press equipment is not available. Use the cam installation tool (CCI P/N 101808401) for this process.

- 5.2.1. With the clutch loosely assembled, set the edge of the clutch body (5) on a clean, flat surface (**Figure 20-20, Page 20-15**).
- 5.2.2. Assemble the threaded bolt (1) through the washer (2), the thrust bearing assembly (3), the second washer (2), and the hub guide (4).

NOTE: It is very important that the bolt, washers, and thrust bearing assembly be assembled in the order described and shown.

- 5.2.3. Slide the bolt (1) through the clutch body (5) until the threaded bolt, washers, bearing, and hub guide are against the fixed face hub (**Figure 20-20, Page 20-15**).
- 5.2.4. Hold the clutch assembly and cam installation tool together and place the fixed face down on spaced blocks (**Figure 20-19, Page 20-15**).
- 5.2.5. Place the cam press hub (6) onto the cam installation bolt and thread it down onto the cam hub, centering the press hub onto the cam hub.
- 5.2.6. Hold the fixed face assembly of the clutch (5) and rotate the moveable face of the clutch one-third turn clockwise.
- 5.2.7. Use two wrenches, and hold the bolt head while tightening the cam press hub (6) pressing the cam onto the keyed shaft. Advance the press hub until it is firm against the shaft end.
- 5.2.8. Remove the cam press hub (6) and installation tool, and install the retaining ring.

NOTE: The retaining ring can be reused if the O.D. does not exceed 1.607 inches (40.82 mm); otherwise, it must be replaced with a new ring (CCI P/N 1014080).

DRIVEN CLUTCH INSTALLATION

1. To install the driven clutch, reverse the removal procedure. Make sure that the washer (12) is mounted with the flat portion of the washer against the driven clutch (**Figure 20-18, Page 20-14**). Secure with a new bolt (11). **See following NOTE.**

NOTE: The bolt (11) must be replaced with a new bolt (CCI P/N 102242101) containing a locking patch that will prevent the bolt from loosening.

2. Tighten the bolt (11) to 18 ft-lb (24.4 N·m).
3. Connect the spark plug.
4. Connect battery cables, positive (+) cable first, and tighten hardware to 144 in-lb (16 N·m). **See Figure 1-1, Page 1-3.** Coat terminals with Battery Terminal Protector Spray (CCI P/N 14305) to minimize corrosion.

SECTION 21 – ELECTRICAL SYSTEM AND TESTING: ELECTRIC VEHICLE

⚠ DANGER

- See General Warning on page 1-1.

⚠ WARNING

- See General Warning on page 1-1.

GENERAL INFORMATION

The electric vehicle uses a 48-volt electrical system that is powered by four 12-volt lead-acid batteries and includes an onboard computer. The electric vehicle uses a shunt-wound 3.2 hp motor and includes several additional features.

- **Shunt-Wound Motor:** The shunt-wound motor, unlike a series motor, is designed so that the speed controller is able to vary the amount of current passing through the field coils independently from the current passing through the armature.
- **Motor Braking:** Under certain conditions a shunt-wound motor also has the ability to act as an electrical brake to slow the vehicle. There are three features of the electrical system which will activate the motor braking function: Walk Away Braking, Pedal Down Motor Braking, and Pedal Up Motor Braking (adjustable with the IQDM-P handset).
- **Walk Away Braking:** the Zero-Speed Detect function will prevent the vehicle from rolling at more than 1 or 3 mph (1.5 or 4.8 km/h) unless the accelerator is pressed. This prevents the possibility of a parked vehicle (with the park brake disengaged) rolling away too fast to be overtaken on foot. If the Walk Away Braking function remains engaged for two seconds or more, a warning buzzer will sound to alert the driver that motor braking has been activated.

⚠ WARNING

- **Walk Away Braking will not limit vehicle speed to 1 mph (1.6 km/h) on very steep grades. Do not operate vehicle on slopes exceeding 20% grades.**
- **Pedal Down Motor Braking:** This feature helps to control vehicle downhill speed. Motor braking is activated when the vehicle reaches the programmed top speed and holds the vehicle at that speed. Motor braking is automatically disengaged when vehicle speed slows below the programmed top speed.
- **Pedal Up Motor Braking (adjustable):** When vehicle speed is above 11 mph (17.7 km/h), releasing the accelerator pedal will activate motor braking, which slows the vehicle speed. Once vehicle speed slows to below approximately 11 mph (17.7 km/h), with the accelerator pedal still released, motor braking will be deactivated and the vehicle will coast freely. This feature is adjustable. Contact your nearest distributor/dealer to inquire about this adjustable feature.
- **Regenerative Braking:** When motor braking is activated, the vehicle motor acts as a generator, slowing the vehicle as it creates energy that is used to charge the batteries.

WIRING DIAGRAM

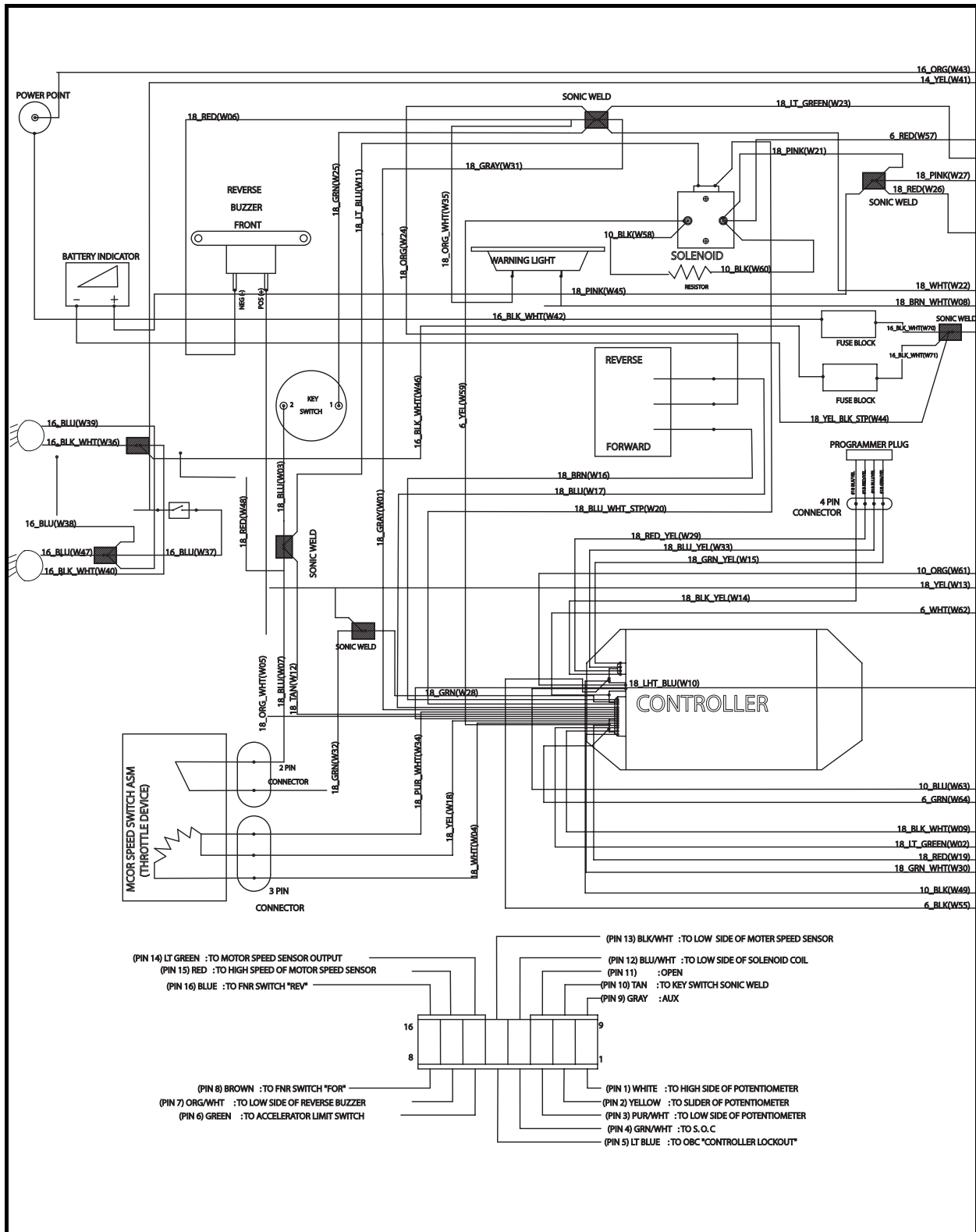

Figure 21-1 Wiring Diagram for Electric Vehicles

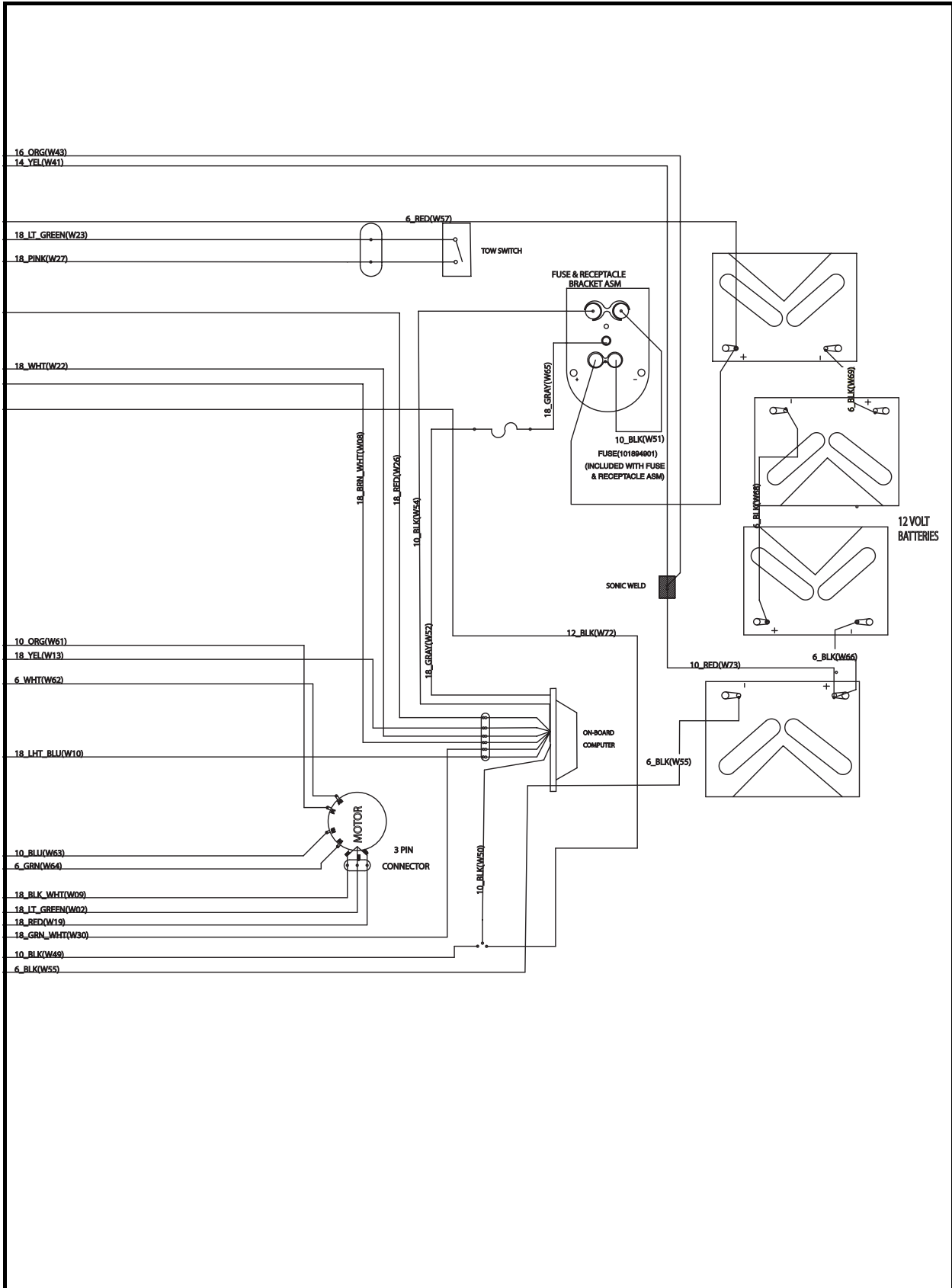

Figure 21-2 Wiring Diagram for Electric Vehicles

- **Tow/Run Switch:** When the Tow/Run switch is in the RUN position, the vehicle will function normally. When the switch is in the TOW position, power to the OBC and controller is shut off, disabling the vehicle operating circuit and zero speed detect, allowing the vehicle to be towed.
- **Motor Protection Circuit:** The operator should never attempt to hold the vehicle on an incline by pressing the accelerator pedal instead of the brake pedal, as motor overheating could result. By reducing the current to the motor during such an occurrence, the motor protection circuit reduces the possibility of motor damage. When this situation arises, a *motor stall fault* is recorded by the speed controller and will be displayed on an IQDM handset in the Diagnostic History menu. **See Motor Stall on page 22-10.**
- **High Pedal Detect:** This function prevents unexpected vehicle movement if the key switch is turned ON after the accelerator is pressed, or the accelerator pedal is pressed when Forward/Reverse switch is used to change the direction of travel. The vehicle will not move until the accelerator is released and pressed again. When this situation arises, a *HPD fault* is recorded by the speed controller and will be displayed on a diagnostic and programming handset in the Diagnostic History menu. **See HPD on page 22-9.**
- **Onboard Computer (OBC):** The OBC, 1) monitors battery condition, 2) monitors the number of energy units used by the vehicle, 3) determines the number of energy units required to recharge the batteries and shuts the charger off when this number is reached, 4) determines when to activate regenerative motor braking, 5) locks out vehicle movement while the charger is plugged into the vehicle charger receptacle, 6) stores operating data, which can be read by the Communication Display Module (CDM). **See Communication Display Module (CDM) on page 21-33.**

TROUBLESHOOTING

The following troubleshooting guides will be helpful in identifying operating difficulties should they occur. The guides include the symptom, probable cause(s) and suggested checks. The procedures used in making these checks can be found in the referenced sections of this maintenance and service supplement.

TROUBLESHOOTING THE VEHICLE WITH THE DIAGNOSTIC HANDSET

We recommend the use of the diagnostic handset (IQDM) for troubleshooting vehicles equipped with the electrical system. Troubleshooting Guide 1 is to be used in conjunction with the handset. Refer to the Diagnostic Handset Owner's Manual for operating instructions. **See also Section 22 – IQ Display Module (IQDM) and IQDM-P Diagnostics. See following WARNING.**

WARNING

- **The vehicle operator should not monitor the diagnostic handset while the vehicle is in motion. A technician can monitor the diagnostic handset while traveling as a passenger in the vehicle. Failure to heed this warning could result in severe personal injury or death.**

In the event that the vehicle is not functioning properly after completing Troubleshooting Guide 1, the technician should proceed to Troubleshooting Guide 2.

If a diagnostic handset is unavailable, the technician should proceed to Troubleshooting Guide 2.

TROUBLESHOOTING GUIDE 1

The following troubleshooting guide is intended for use with a diagnostic handset. For handset operating instructions, see **Section 22 – IQ Display Module (IQDM) and IQDM-P Diagnostics**. See following **NOTE**.

NOTE: Before troubleshooting the vehicle, check the diagnostic history from the Special Diagnostics Menu. Note any fault codes.

TROUBLESHOOTING GUIDE 1		
SYMPTOM	POSSIBLE CAUSES	CORRECTIVE ACTION
Test Menu – THROTTLE % value does not increase as the accelerator pedal is pressed or Diagnostic Menu – THROTTLE FAULT 1 fault code	Loose or disconnected three-pin connector at the MCOR or broken wire	Repair and/or connect the three-pin connector to the MCOR
	Loose or disconnected 16-pin connector at speed controller or broken wire	Repair and/or connect the 16-pin connector to the speed controller
	Failed MCOR	Test Procedure 4 – MCOR Voltage on page 21-12
Test Menu – HEATSINK °C indicates that temperature is above 85 °C (145 °F) or Diagnostic Menu – THERMAL CUTBACK fault code	Over-adjusted brakes	See Brake Adjustment, Section 6, Page 6-8.
	Vehicle is over-loaded	Ensure that vehicle is not over-loaded before returning to operation
Test Menu – ARM PWM value does not reach 100% when vehicle is at full speed	Failed MCOR	Test Procedure 4 – MCOR Voltage on page 21-12
	Improper pedal group adjustment	See Pedal Group Adjustment – Electric Vehicles, Section 5, Page 5-16.
Test Menu – SPEED PULSES menu item indicates that speed pulses are OFF when the vehicle is in motion or Diagnostic Menu – SPEED SENSOR fault code	Loose or disconnected motor speed sensor or broken wire	Repair and/or connect the three-pin connector to the motor speed sensor
	Loose or disconnected 16-pin connector at speed controller or broken wire	Repair and/or connect the 16-pin connector to the speed controller
	Failed motor speed sensor	Test Procedure 13 – Motor Speed Sensor on page 21-29
Test Menu – FOOT INPUT menu item indicates that the MCOR internal limit switch is always ON or always OFF.	Loose or disconnected two-pin connector at the MCOR or broken wire	Repair and/or connect the two-pin connector to the MCOR
	Loose or disconnected 16-pin connector at speed controller or broken wire	Repair and/or connect the 16-pin connector to the speed controller
	Failed MCOR	Test Procedure 8 – Key Switch and MCOR Limit Switch Circuit on page 21-16
Test Menu – FORWARD INPUT and/or REVERSE INPUT does not indicate the correct reading or Diagnostic Menu – PROC/WIRING fault code	Loose or disconnected Forward/Reverse rocker switch (quick disconnect terminals) or broken wire	Repair and/or connect the quick disconnect terminals to the Forward/Reverse switch
	Loose or disconnected Forward/Reverse rocker switch (three-pin connector) or broken wire	Repair and/or connect the three-pin connector from the Forward/Reverse switch to the wire harness
	Loose or disconnected 16-pin connector at speed controller or broken wire	Repair and/or connect the 16-pin connector to the speed controller
	Failed Forward/Reverse rocker switch	Test Procedure 15 – Forward/Reverse Rocker Switch on page 21-30
Troubleshooting Guide continued on next page...		

TROUBLESHOOTING GUIDE 1		
SYMPTOM	POSSIBLE CAUSES	CORRECTIVE ACTION
Test Menu – MAIN CONT (solenoid) does not indicate ON when the solenoid should be activated. or Diagnostic Menu – MAIN CONT DNC (main contactor (solenoid) did not close) fault code	Speed controller logic malfunction	Disconnect the batteries and allow the speed controller capacitors to discharge. See WARNING “To avoid unintentionally starting...” in General Warning on page 1-1. Reconnect the batteries and see if the symptom returns.
	Loose, broken, or disconnected wire(s) at solenoid or B+ speed controller terminal	Repair and/or connect the loose or disconnected wire(s)
	Loose or disconnected 16-pin connector at speed controller or broken wire	Repair and/or connect the 16-pin connector to the speed controller
	Failed solenoid	Replace solenoid. See Solenoid Removal on page 23-10.
Test Menu – KEY INPUT does not indicate ON when key switch is in the ON position	Loose or disconnected wires at key switch terminals or broken wire	Repair and/or connect the quick disconnect terminals to the Forward/Reverse switch
	Loose or disconnected 16-pin connector at speed controller or broken wire	Repair and/or connect the 16-pin connector to the speed controller
	Failed key switch	Test Procedure 8 – Key Switch and MCOR Limit Switch Circuit on page 21-16
Diagnostic Menu – THROTTLE FAULT 1 fault code	Loose or disconnected three-pin connector at the MCOR or broken wire	Repair and/or connect the three-pin connector to the MCOR
	Loose or disconnected 16-pin connector at speed controller or broken wire	Repair and/or connect the 16-pin connector to the speed controller
	Failed MCOR	Test Procedure 4 – MCOR Voltage on page 21-12
Diagnostic Menu – HW FAILSAFE (Hardware Failsafe) fault code	Armature drive FET's (field-effect transistors) inside speed controller have failed	Replace the speed controller. See Speed Controller Removal, Section 23, Page 23-13.
	Speed controller logic malfunction	Disconnect the batteries and allow the speed controller capacitors to discharge. See WARNING “To avoid unintentionally starting...” in General Warning on page 1-1. Reconnect the batteries and see if the symptom returns.
Diagnostic Menu – MAIN WELDED (main solenoid contacts welded) fault code	solenoid contacts have failed closed	Replace solenoid. See Solenoid Removal on page 23-10.
Diagnostic Menu – MAIN DRIVER ON or MAIN DRIVER OFF fault code	Speed controller logic malfunction	Disconnect the batteries and allow the speed controller capacitors to discharge. See WARNING “To avoid unintentionally starting...” in General Warning on page 1-1. Reconnect the batteries and see if the symptom returns.
	Failure of the FET that controls the solenoid coil	Replace the speed controller. See Speed Controller Removal, Section 23, Page 23-13.
Diagnostic Menu – MAIN COIL FAULT fault code or Diagnostic Menu – MAIN DROPOUT fault code	Solenoid coil has failed in an open condition	Replace solenoid. See Solenoid Removal on page 23-10.
Troubleshooting Guide continued on next page...		

TROUBLESHOOTING GUIDE 1		
SYMPTOM	POSSIBLE CAUSES	CORRECTIVE ACTION
Diagnostic Menu – FIELD MISSING fault code	Loose or disconnected motor field coil wires at motor or speed controller or broken wire	Repair and/or connect the field coil wires
	Failure of the motor field windings	Section 26 – Motor (Model 5BC59JBS6390) or Section 27 – Motor (Model EJ4-4001)
	Failure of the FET's that control field current	Replace the speed controller. See Speed Controller Removal, Section 23, Page 23-13.
Diagnostic Menu – HPD (high pedal detect) fault code	Operator error	Train operators to fully remove foot from accelerator pedal before turning key switch to the ON position or changing the selected direction with the Forward/Reverse switch
Diagnostic Menu – LOW BATTERY fault code	Batteries require charging	Place batteries on battery charger and allow them to fully charge
	Improperly maintained or failed batteries	Section 24 – Batteries: Electric Vehicles
Diagnostic Menu – OPEN ARMATURE fault code	Loose or disconnected motor armature wires at motor or speed controller or broken wire	Repair and/or connect the motor armature wires
	Failure of the motor armature or brushes	Section 26 – Motor (Model 5BC59JBS6390) or Section 27 – Motor (Model EJ4-4001)
	Failure of the FET's that control armature current	Replace the speed controller. See Speed Controller Removal, Section 23, Page 23-13.
Troubleshooting Guide continued on next page...		

TROUBLESHOOTING GUIDE 2

TROUBLESHOOTING GUIDE 2		
SYMPTOM	POSSIBLE CAUSES	CORRECTIVE ACTION
Vehicle does not operate	Batteries discharged	Charge batteries
	Improper or poor battery connections	Check vehicle wiring. See Wiring Diagram on page 21-2.
	Battery charger is connected to the vehicle – Solenoid lockout feature has disabled the vehicle	Disconnect the battery charger from the vehicle
	Onboard computer failure	Test Procedure 2 – Onboard Computer Solenoid Lockout Circuit on page 21-11
	Key switch and MCOR limit switch circuit	Check for loose or disconnected wires at key switch and MCOR
	Failed key switch	Test Procedure 8 – Key Switch and MCOR Limit Switch Circuit on page 21-16
	Failed MCOR	Test Procedure 8 – Key Switch and MCOR Limit Switch Circuit on page 21-16. See also Test Procedure 4 – MCOR Voltage on page 21-12.
	Forward/Reverse rocker switch	Test Procedure 15 – Forward/Reverse Rocker Switch on page 21-30
	Solenoid – loose wires	Test Procedure 3 – Solenoid Activating Coil on page 21-12
	Solenoid – failed coil	Test Procedure 3 – Solenoid Activating Coil on page 21-12
	Solenoid – failed solenoid diode	Test Procedure 3 – Solenoid Activating Coil on page 21-12
	Speed controller thermal cutback	Allow controller to cool and ensure that vehicle is not over-loaded before returning to operation
	16-pin connector at speed controller	Check for loose or disconnected wires at the 16-pin connector. See also Test Procedure 9 – 16-Pin Connector on page 21-18.
	High pedal detect	Cycle accelerator pedal
	Motor stall	Cycle accelerator pedal
	Motor failure	Section 26 – Motor (Model 5BC59JBS6390) or Section 27 – Motor (Model EJ4-4001)
	Failed Tow/Run switch	Test Procedure 6 – Tow/Run Switch on page 21-15
Speed controller failure	Replace speed controller. See Speed Controller Removal, Section 23, Page 23-13.	
Troubleshooting Guide continued on next page...		

TROUBLESHOOTING GUIDE 2		
SYMPTOM	POSSIBLE CAUSES	CORRECTIVE ACTION
Vehicle runs slowly	Speed sensor disconnected or failed	Test Procedure 13 – Motor Speed Sensor on page 21-29
	Incorrect speed setting	To change the programmed top speed of the vehicle, a diagnostic and programming handset must be used
	Wiring – improperly wired	Check vehicle wiring. See Wiring Diagram on page 21-2.
	Batteries discharged	Charge batteries
	MCOR malfunction	Test Procedure 4 – MCOR Voltage on page 21-12
	Motor – loose wires	Inspect and tighten all wire connections at the motor
	Failed motor	Replace motor. See Motor Removal on page 26-2 or page 27-2.
	Vehicle is over-loaded	Ensure that vehicle is not over-loaded before returning to operation
	Speed controller failure	Replace speed controller. See Speed Controller Removal, Section 23, Page 23-13.
	Brakes – improperly adjusted	See Brake Adjustment on page 6-8.
	Tires – under-inflated or flat tires	See Section 8 – Wheels and Tires.
Vehicle operates, but motor braking function does not	Wiring – improperly wired	Check vehicle wiring. See Wiring Diagram on page 21-2.
	Speed sensor disconnected or failed	Test Procedure 13 – Motor Speed Sensor on page 21-29
Vehicle will run in forward, but not in reverse or will run in reverse but not forward	Forward/Reverse rocker switch – improperly wired	Test Procedure 15 – Forward/Reverse Rocker Switch on page 21-30
	Motor – improperly wired	Check motor wiring. See Wiring Diagram on page 21-2.
	Speed controller – improperly wired or failed speed controller FET	Check vehicle wiring. See Wiring Diagram on page 21-2.
Vehicle operates, but battery charger does not charge batteries	Onboard computer – gray wire or fuse	Test Procedure 11 – Onboard Computer Gray Wire and Fuse on page 21-28
	Battery charger connections – loose wires at receptacle or batteries	Check wire connections and tighten if necessary.
	Battery charger	Refer to the appropriate battery charger maintenance and service manual

TEST PROCEDURES

Using the following procedures, the entire electrical system can be tested without major disassembly of the vehicle. **See following WARNING.**

WARNING

- If wires are removed or replaced, make sure wiring and wire harness are properly routed and secured. Failure to properly route and secure wiring could result in vehicle malfunction, property damage, personal injury, or death.

INDEX OF TEST PROCEDURES

1. Batteries / Voltage Check
2. Onboard Computer Solenoid Lockout Circuit
3. Solenoid Activating Coil
4. MCOR Voltage
5. A1 and A2 Motor Voltage
6. Tow/Run Switch
7. Battery Pack Voltage (Under Load)
8. Key Switch and MCOR Limit Switch Circuit
9. 16-Pin Connector
10. Onboard Computer Silicon-Controlled Rectifier (SCR) Circuit
11. Onboard Computer Gray Wire and Fuse
12. Voltage at Charger Receptacle Red Wire Socket
13. Motor Speed Sensor
14. Solenoid Continuity
15. Forward/Reverse Rocker Switch
16. Reverse Buzzer
17. Rebooting the Onboard Computer
18. Battery Warning Light

TEST PROCEDURE 1 – BATTERIES / VOLTAGE CHECK

See General Warning on page 1-1.

NOTE: *The batteries must be properly maintained and fully charged in order to perform the following test procedures. Battery maintenance procedures, including watering information and allowable mineral content, can be found in Section 24 of this manual. See **Battery Care on page 24-9.***

The battery voltage can be displayed with the Diagnostic Handset. If a handset is not available, proceed to Batteries / Voltage Check without the Diagnostic Handset on page 21-11.

Batteries / Voltage Check with the Diagnostic Handset

1. Connect the handset to the vehicle. **See Plugging the Handset into the Vehicle on page 22-1.**
2. Access the Test menu and select BATT VOLTAGE by using the SCROLL DISPLAY buttons. The handset should indicate at least 48 volts with the batteries fully charged. If not, check for loose battery connections or a battery installed in reverse polarity. Refer to Section 24 – Batteries: Electric Vehicles, for further details on battery testing.

Batteries / Voltage Check without the Diagnostic Handset

With batteries connected and using a multimeter set to 200 volts DC, place red (+) probe on the positive (+) post of battery no. 1 and the black (–) probe on the negative (–) post of battery no. 4 (**Figure 21-3, Page 21-11**). The multimeter should indicate at least 48 volts with the batteries fully charged. If not, check for loose battery connections or a battery installed in reverse polarity. Refer to Section 24 – Batteries: Electric Vehicles, for further details on battery testing.

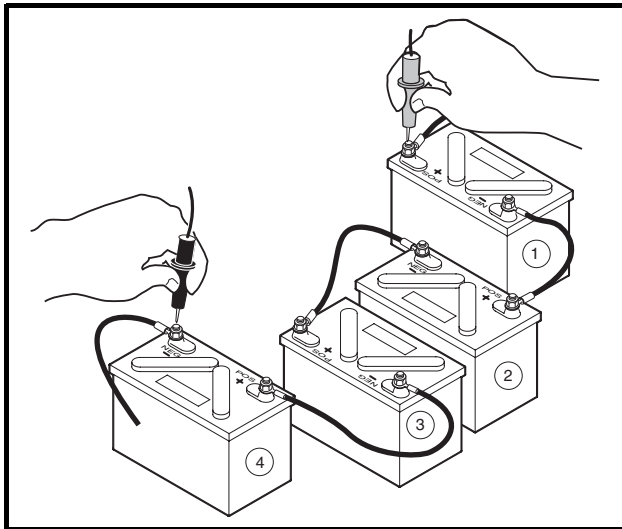

Figure 21-3 Battery Voltage Test

TEST PROCEDURE 2 – ONBOARD COMPUTER SOLENOID LOCKOUT CIRCUIT

See General Warning on page 1-1.

The solenoid lockout circuit disables the vehicle when the battery charger is plugged into the vehicle. Use the following procedure to test the solenoid lockout circuit:

1. With batteries connected, place the Tow/Run switch in the RUN position.
2. Set a multimeter to 200 volts DC. Place black (–) probe on battery no. 4 negative post and red (+) probe (with insulation-piercing probe) on the blue onboard computer wire (at a point between the OBC and the six-pin connector). The reading should be approximately 48-50 volts (full battery voltage). If the reading is not 48-50 volts, proceed to step 3. If the reading is 48-50 volts, proceed to Test Procedure 3 – Solenoid Activating Coil on page 21-12.
3. Place insulation-piercing probe on the light blue 18-gauge wire at a point between OBC six-pin connector and main wire harness. If reading is 48-50 volts, check the wire terminal connectors inside six-pin connector at OBC six-pin connector. Make sure pins are properly aligned inside housing. Make sure wire colors match and are connected to the correct terminals.

4. If reading is zero volts, plug the charger DC cord into the vehicle charger receptacle. If the dash light illuminates for 10 seconds, the OBC is now powered-up. Unplug the DC cord; the reading at the OBC blue wire should be approximately 48-50 volts. If the vehicle now operates normally, the DC cord has powered up the electrical system. The electrical system should also power-up when the accelerator pedal is pressed. To check the accelerator pedal function, see Test Procedure 4 – MCOR Voltage on page 21-12.
5. If the dash light illuminates for 10 seconds and the vehicle does not operate:
 - 5.1. Set a multimeter to 200 volts DC. Place black (–) probe on battery number 4 and place red (+) probe (with insulation-piercing probe) on blue 18-gauge wire at OBC six-pin connector.
 - 5.2. With Tow/Run switch in the RUN position, the voltage reading should be approximately 48 volts.
6. If the dash light does not illuminate and the vehicle does not operate, check the OBC activation circuit.
 - 6.1. Set a multimeter to 200 volts DC. Place the black (–) probe on the battery no. 4 negative post and place the red (+) probe (with insulation-piercing probe) on the red 18-gauge wire located on the OBC side of the six-pin connector. The reading should be approximately 48 volts. If the reading is incorrect, test the Tow/Run switch and connecting wires. **See Test Procedure 6 – Tow/Run Switch on page 21-15.**
 - 6.2. Set a multimeter to 200 volts DC. Place the black (–) probe on the battery no. 4 negative post and place the red (+) probe (with insulation-piercing probe) on the red 18-gauge wire (harness side of six-pin connector). Multimeter should indicate 48 volts. If voltage is correct, check connections in the six-pin connector. If connections are correct, OBC activation circuit has failed. Replace OBC.

TEST PROCEDURE 3 – SOLENOID ACTIVATING COIL

See General Warning on page 1-1.

Place red (+) probe of the multimeter on the positive (+) solenoid terminal. Place the black (–) probe on the other small solenoid terminal. A reading of 180 to 190 ohms should be obtained (**Figure 21-4, Page 21-12**). If not, replace the solenoid.

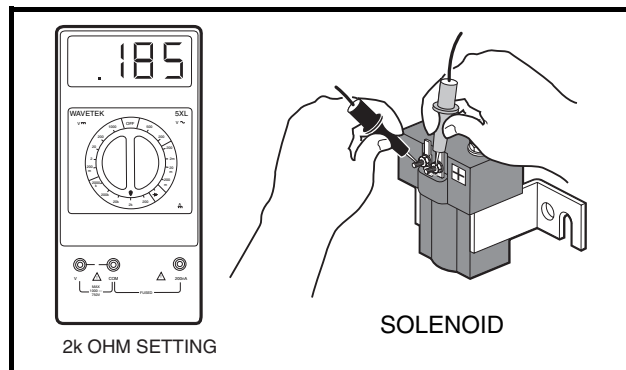

Figure 21-4 Activating Coil Test

TEST PROCEDURE 4 – MCOR VOLTAGE

See General Warning on page 1-1.

The accelerator position, which is proportional to the MCOR voltage, can be displayed with the diagnostic handset. If a handset is not available, proceed to MCOR Voltage Test without the Diagnostic Handset on page 21-13.

MCOR Voltage Test with the Diagnostic Handset

1. Place chocks at the front wheels and lift the rear of the vehicle with a chain hoist or floor jack. Position jack stands under the frame crossmember between the spring mount and side stringer, just forward of each rear wheel. **See WARNING “Lift only one end...” in General Warning on page 1-1. See following NOTE.**

NOTE: The key switch should be placed in the OFF position and left in the OFF position for the duration of this test.

2. Connect the handset to the vehicle. **See Plugging the Handset into the Vehicle on page 22-1.**
3. Access the Test menu and select THROTTLE % by using the SCROLL DISPLAY buttons.
4. The handset should indicate 0 % with the pedal not pressed. While monitoring the handset display screen, slowly press the accelerator pedal. As the pedal is pressed, the handset should indicate a rise from 0 % (pedal not pressed) to 100 % (pedal fully pressed).
5. If the MCOR does not operate as described in step 4, proceed to MCOR Voltage Test without the Diagnostic Handset on page 21-13.

MCOR Voltage Test without the Diagnostic Handset

1. Place chocks at the front wheels and lift the rear of the vehicle with a chain hoist or floor jack. Position jack stands under the frame crossmember between the spring mount and side stringer, just forward of each rear wheel. **See WARNING “Lift only one end...” in General Warning on page 1-1. See following NOTE.**

NOTE: The key switch should be placed in the OFF position and left in the OFF position for the duration of this test.

2. With the batteries connected, place Tow/Run switch in RUN. Using a multimeter set to 200 volts DC, place red (+) probe on battery no. 1 positive post and place black (–) probe (with insulation-piercing probe) on the purple/white wire at a point close to the three-pin connector at the MCOR. The reading should be approximately 48-50 volts (full battery voltage).
3. If reading is zero volts, check the purple/white wire continuity from the three-pin connector at the MCOR to the 16-pin connector at the speed controller. Check terminal positions in three-pin connector at the MCOR and the 16-pin connector. If all of the continuity readings are correct and the connectors are wired correctly, replace the speed controller.
4. With multimeter set to 20 volts DC, place the black (–) probe on battery no. 4 negative post and the red (+) probe (with insulation-piercing probe) on the white wire at a point close to the three-pin connector at the MCOR. The reading should be approximately 4.65 volts.
5. If reading is zero volts, check the white wire continuity from the three-pin connector at the MCOR to the 16-pin connector at the speed controller. Check terminal positions in three-pin connector at the MCOR and the 16-pin connector. If all of the continuity readings are correct and the connectors are wired correctly, replace the speed controller.
6. With multimeter set to 20 volts DC, place the black (–) probe on battery no. 4 negative post and the red (+) probe (with insulation-piercing probe) on the no. 18 yellow wire at a point close to three-pin connector at the MCOR. The reading should be approximately 0.32 volts with the pedal up. Slowly press the accelerator pedal and note the readings on the multimeter. As the pedal is pressed, the reading should increase until it reaches 4.65 volts when the pedal is fully pressed.
7. If reading does not increase as the pedal is pressed, replace the MCOR.

8. If the reading is not approximately 4.60 volts with the pedal fully pressed, the vehicle will not operate at rated top speed. Check the MCOR resistance.
 - 8.1. Disconnect the battery cables as instructed. **See WARNING “To avoid unintentionally starting...” in General Warning on page 1-2.**
 - 8.2. Disconnect the 16-pin connector at the speed controller.
 - 8.3. Set a multimeter to 20k ohms. Connect the red (+) probe of the multimeter to the yellow wire at the MCOR three-pin connector with an insulation piercing probe. Connect black (–) probe to the purple/white wire with an insulation-piercing probe.
 - 8.4. With the accelerator pedal fully up (not pressed), the multimeter should read approximately 1k ohms.
 - 8.5. Slowly press the accelerator pedal while monitoring the multimeter. The resistance should rise as the pedal is pressed. When the pedal is all the way to the floor, the multimeter should indicate between 5.67k ohms and 7.43k ohms.
 - 8.6. Using a multimeter set for 20k ohms, connect the red (+) probe of the multimeter to the yellow wire at the MCOR three-pin connector with an insulation piercing probe. Connect black (–) probe to the white wire with an insulation-piercing probe.
 - 8.7. With the accelerator pedal fully up (not pressed), the multimeter should indicate between 5.67k ohms and 7.43k ohms.
 - 8.8. Slowly press the accelerator pedal while monitoring the multimeter. The resistance should drop as the pedal is pressed. When the pedal is all the way to the floor, the multimeter should indicate approximately 1k ohms.
 - 8.9. If the MCOR does not operate as described, replace the MCOR.

TEST PROCEDURE 5 – A1 AND A2 MOTOR VOLTAGE

See General Warning on page 1-1.

1. Place chocks at the front wheels and lift the rear of the vehicle with a chain hoist or floor jack. Position jack stands under the frame crossmember between the spring mount and side stringer, just forward of each rear wheel. **See WARNING “Lift only one end...” in General Warning on page 1-1.**
2. With the batteries connected and using a multimeter set to 200 volts DC, place the black (–) probe on the A2 motor terminal (white wire) and connect the red (+) probe to the A1 (green wire) motor terminal.
3. With Tow/Run switch in the RUN position, place the Forward/Reverse switch in the FORWARD position, turn key switch to the ON position and slowly press accelerator pedal.
4. As the accelerator pedal is pressed, the voltage reading should increase from approximately 5 volts RMS when the MCOR limit switch closes, to approximately 48 volts RMS with the accelerator pedal fully pressed.
 - 4.1. If there is no voltage reading, check the MCOR. **See Test Procedure 4 – MCOR Voltage on page 21-12.** Also check the continuity of the large posts of the solenoid. **See Test Procedure 14 – Solenoid Continuity on page 21-30.**
 - 4.2. Disconnect the battery cables as instructed. **See WARNING “To avoid unintentionally starting...” in General Warning on page 1-2.**
 - 4.3. Check continuity on A1 and A2 motor terminal posts and continuity of the F1 and F2 motor terminal posts. Also, check continuity of all motor wires. **See Section 26 – Motor (Model 5BC59JBS6390) or Section 27 – Motor (Model EJ4-4001).**

TEST PROCEDURE 6 – TOW/RUN SWITCH

See General Warning on page 1-1.

Tow/Run Switch Test with the Diagnostic Handset

1. With the Tow/Run switch in the RUN position, connect the handset to the vehicle. **See Plugging the Handset into the Vehicle on page 22-1.**
2. Immediately after the handset is connected to the vehicle, the screen should display a copyright notice and the Diagnostic Handset model number.
3. If the handset display screen is blank, drive the vehicle a short distance to activate the onboard computer.
4. If the vehicle will not operate, proceed to Tow/Run Switch Test without the Diagnostic Handset.
5. If the handset display screen begins to work after the vehicle has been driven, turn the key switch to the OFF position and proceed to step 6; otherwise, perform the following procedure, Tow/Run Switch Test without the Diagnostic Handset.
6. With the handset still connected to the vehicle, place the Tow/Run Switch in the TOW position and wait 90 seconds.
7. If the handset display screen goes blank after 90 seconds, the Tow/Run switch and connecting wires are operating correctly.
8. If the handset display screen is still active after 90 seconds, the switch has failed closed. Replace the Tow/Run switch. **See Tow/Run Switch Removal on page 23-7.**

Tow/Run Switch Test without the Diagnostic Handset

1. Set a multimeter to 200 volts DC and with the batteries connected, connect the black (–) probe to the negative post of battery no. 4 and connect red (+) probe (with insulation-piercing probe) on the light green wire close to the two-pin connector on the Tow/Run switch.
2. With the Tow/Run switch in the RUN position, the reading should be approximately 48-50 volts. With the switch in the TOW position, the reading should be below approximately 5 volts.
3. If the reading is above 5 volts with the switch in the TOW position, replace the switch.
4. If the reading is below 5 volts with switch in the RUN position, check continuity of the two-pin connector and the pink 18-gauge wire from the large post of the solenoid to the two-pin connector at the Tow/Run switch.
5. If the two-pin connector and pink wire continuity readings are correct, replace the Tow/Run switch.

TEST PROCEDURE 7 – BATTERY PACK VOLTAGE (UNDER LOAD)

See General Warning on page 1-1.

1. Before proceeding with this test procedure, the batteries must be connected and fully charged. Connect the positive (+) lead of a 36 to 48-volt battery discharge machine (CCI P/N 101831901), to battery no. 1 positive post and connect the negative (–) lead to battery no. 4 negative post. Record the voltage reading from discharge machine.
2. Turn the discharge machine on and record the voltage reading of battery pack while under load.
3. A fully charged set of batteries in good condition should read between 46-49 volts while under load.
4. A reading of 32-46 volts indicates discharged or failed batteries. Each battery should be checked with a multimeter while under load.
5. A reading of 32 volts or less will not activate discharge machine. If the voltage of the batteries is below 32 volts, the batteries are deeply discharged or have failed.

6. Recording the battery pack voltage reading while under load provides a more accurate diagnosis of the condition of the batteries. When the discharge machine is ON, it places the battery pack under load and many times can help determine if one or more batteries in the set have failed. Testing battery voltage while the batteries are not under load will not always indicate the true condition of the batteries. For more information about the batteries, refer to Section 24 – Batteries: Electric Vehicles.

TEST PROCEDURE 8 – KEY SWITCH AND MCOR LIMIT SWITCH CIRCUIT

See General Warning on page 1-1.

Key Switch and MCOR Limit Switch Circuit Test with the Diagnostic Handset

1. Place chocks at the front wheels and lift the rear of the vehicle with a chain hoist or floor jack. Position jack stands under the frame crossmember between the spring mount and side stringer, just forward of each rear wheel. **See WARNING “Lift only one end...” in General Warning on page 1-1.**
2. Turn the key switch to the OFF position and place the Forward/Reverse switch in the NEUTRAL position.
3. Connect the handset to the vehicle. **See Plugging the Handset into the Vehicle on page 22-1.**
4. Test the key switch.
 - 4.1. Access the Test menu, and select KEY INPUT by using the SCROLL DISPLAY buttons. The handset should indicate OFF when the key switch is in the OFF position.
 - 4.2. While monitoring the handset display screen, turn the key switch to the ON position. The handset should indicate ON.
 - 4.3. If the handset does not indicate that KEY INPUT is ON when the key switch is in the ON position, proceed to the following procedure, Key Switch and MCOR Limit Switch Circuit Test without the Diagnostic Handset. If the key switch functions as described, proceed to the following step. **See following NOTE.**

NOTE: The key switch *MUST* function properly in order to test the MCOR limit switch with the diagnostic handset.

5. Test the MCOR limit switch.
 - 5.1. Select FOOT INPUT on the Test menu by using the SCROLL DISPLAY buttons on the handset.
 - 5.2. The handset should indicate that FOOT INPUT is OFF when the accelerator pedal is not pressed, regardless of the key switch position.
 - 5.3. With the key switch in the ON position, press the accelerator pedal. The handset should indicate that FOOT INPUT is ON when the accelerator pedal is pressed.
6. If any reading is obtained that is not described in steps 4 and 5, perform the following steps:
 - 6.1. Check the pedal group for proper adjustment. **See Section 5 – Pedal Group Adjustment – Electric Vehicles.**
 - 6.2. Check the wiring of the key switch and MCOR. **See Wiring Diagram on page 21-2.**
 - 6.3. Check the continuity of the key switch wires and the MCOR limit switch wires.
7. If the problem was not found, proceed to the following procedure, Key Switch and MCOR Limit Switch Circuit Test without the Diagnostic Handset on page 21-17.

Key Switch and MCOR Limit Switch Circuit Test without the Diagnostic Handset

1. Disconnect the battery cables as instructed. **See WARNING “To avoid unintentionally starting...” in General Warning on page 1-1.**
2. Place chocks at the front wheels and lift the rear of the vehicle with a chain hoist or floor jack. Position jack stands under the frame crossmember between the spring mount and side stringer, just forward of each rear wheel. **See WARNING “Lift only one end...” in General Warning on page 1-2.**
3. Turn the key switch to the OFF position and place the Forward/Reverse switch in the NEUTRAL position.
4. Test the key switch.
 - 4.1. Remove the instrument panel. **See step 3 of Key Switch Removal on page 23-1.**
 - 4.2. Set a multimeter to 200 ohms. Place the red (+) probe on the key switch terminal with the blue wire. Place the black (–) probe on the other key switch terminal.
 - 4.3. With the key switch in the OFF position, the multimeter should indicate that continuity is not present.
 - 4.4. With the key switch in the ON position, the multimeter should indicate that continuity is present.
 - 4.5. If any other reading is obtained, replace the key switch. **See Key Switch Removal on page 23-1.**
 - 4.6. If the key switch operates as described in the previous steps, install the dash panel in the reverse order of removal and proceed to the following step.
5. Test the MCOR limit switch. **See following NOTE.**

NOTE: *Make sure that the key switch is operating correctly and that the key switch and dash panel are properly installed before proceeding.*

- 5.1. With batteries connected and using a multimeter set to 200 volts DC, place the black (–) probe on the battery no. 4 negative post and place the red (+) probe (with insulation-piercing probe) on the green wire close to the two-pin connector on the MCOR.
- 5.2. With Tow/Run switch in the RUN position, key switch in the ON position, and Forward/Reverse rocker switch in the NEUTRAL position, the voltage reading should be zero volts. When the accelerator pedal is pressed, the voltage reading should be approximately 48 volts (full battery voltage).
- 5.3. If the voltage reading is 48 volts when the accelerator pedal is not pressed, check the pedal group for proper adjustment. **See Section 5 – Pedal Group Adjustment – Electric Vehicles.**
- 5.4. If the voltage reading is zero volts when the accelerator pedal is pressed, check the limit switch circuit using the following test procedures.
 - 5.4.1. Set a multimeter to 200 volts DC. Place black (–) probe on battery no. 4 negative post and the place red (+) probe (with insulation-piercing probe) on the blue wire where it connects to the MCOR. With the key switch ON, the reading should be approximately 48 volts (full battery voltage).
 - 5.4.2. If the reading is zero volts, check the continuity of the blue wire that goes from the key switch to the MCOR.
 - 5.4.3. If the reading is approximately 48 volts, proceed to the following step.
 - 5.4.4. Set a multimeter to 200 volts DC. Place the black (–) probe on the battery no. 4 negative post and place the red (+) probe (with insulation-piercing probe) on the green wire where it connects to the MCOR. With the Tow/Run switch in the RUN position, the key switch ON, the Forward/Reverse rocker switch in NEUTRAL and the accelerator pedal pressed, the reading should be approximately 48 volts (full battery voltage).
 - 5.4.5. If the reading is zero volts, test the continuity of the MCOR limit switch and the green wire. If the limit switch does not pass the continuity test, replace the MCOR. **See MCOR Removal on page 23-8.**

TEST PROCEDURE 9 – 16-PIN CONNECTOR

See **General Warning** on page 1-1.

1. Disconnect the battery cables as instructed. See **WARNING “To avoid unintentionally starting...”** in **General Warning** on page 1-1.
2. Disconnect the 16-pin connector from the speed controller. Inspect terminal ends inside plug to ensure they are in position and seated in plug housing. If any terminals look like they are not pushed all the way into the connector, gently push the terminals until they are firmly seated in the 16-pin connector. After each terminal has been pushed into the housing, gently pull on the wire to ensure it is locked into place.
3. Check wires in the plug to make sure none are broken at the terminal pin crimp. Repair or replace as required.
4. Check the wire colors of each wire and make sure that the colors for each pin position match the wire colors in the wiring diagram. See **Wiring Diagram** on page 21-2.
5. When connecting the 16-pin connector to the controller, push plug into controller receptacle with enough force to lock plug into place. An audible click will be heard when plug is properly seated to the controller.

A procedure is provided for testing each of the wires in the 16-pin connector. Refer to the following chart for the appropriate procedure for each pin in the 16-pin connector.

If the results of any of the referenced procedures are different from those described in the procedure, check the continuity of the wires in the wire harness and test the connected components with the appropriate test procedures. See **Index of Test Procedures** on page 21-10.

SPEED CONTROLLER 16-PIN CONNECTOR WIRE	TEST PROCEDURE
Pin 1 – White (18-gauge)	Test Procedure 9A – Pins 1, 2, and 3 on page 21-19
Pin 2 – Yellow (18-gauge)	
Pin 3 – Purple/White (18-gauge)	
Pin 4 – Green/White (18-gauge)	Reserved for future use. Wire serves no function at this time
Pin 5 – Light Blue (18-gauge)	Test Procedure 9B – Pin 5 on page 21-20
Pin 6 – Green (18-gauge)	Test Procedure 9C – Pin 6 on page 21-21
Pin 7 – Orange/White (18-gauge)	Test Procedure 9D – Pin 7 on page 21-22
Pin 8 – Brown (18-gauge)	Test Procedure 9E – Pins 8 and 16 on page 21-23
Pin 9 – Gray (18-gauge)	Test Procedure 9F – Pin 9 on page 21-24
Pin 10 – Tan (18-gauge)	Test Procedure 9G – Pin 10 on page 21-26
Pin 11 – Open (no wire)	
Pin 12 – Blue/White (18-gauge)	Test Procedure 9H – Pin 12 on page 21-27
Pin 13 – Black/White (18-gauge)	Test continuity of each wire and perform Test Procedure 13 – Motor Speed Sensor on page 21-29
Pin 14 – Light Green (18-gauge)	
Pin 15 – Red (18-gauge)	
Pin 16 – Blue (18-gauge)	Test Procedure 9E – Pins 8 and 16 on page 21-23

Test Procedure 9A – Pins 1, 2, and 3

See General Warning on page 1-1.

Pins 1, 2, and 3 in the 16-pin connector provide a connection point from the MCOR potentiometer to the speed controller.

1. Disconnect the battery cables as instructed. **See WARNING “To avoid unintentionally starting...” in General Warning on page 1-1.**
2. Place chocks at the front wheels and lift the rear of the vehicle with a chain hoist or floor jack. Position jack stands under the frame crossmember between the spring mount and side stringer, just forward of each rear wheel. **See WARNING “Lift only one end...” in General Warning on page 1-1.**
3. Disconnect the 16-pin connector at the speed controller.
4. Set a multimeter to 20k ohms. Insert the red (+) probe of the multimeter into pin 2 (yellow wire) of the 16-pin connector. **See following CAUTION.** Insert the black (–) probe into pin 3 (purple/white wire) of the 16-pin connector (**Figure 21-5, Page 21-19**).

CAUTION

- Do not fully insert probes into the 16-pin plug. Doing so can result in a poor connection.

5. With the accelerator pedal fully up (not pressed), the multimeter should read approximately 1k ohms.
6. Slowly press the accelerator pedal while monitoring the multimeter. The resistance should rise as the pedal is pressed. When the pedal is all the way to the floor, the multimeter should indicate between 5.67k ohms and 7.43k ohms.
7. Set a multimeter to 20k ohms. Insert the red (+) probe of the multimeter into pin 2 (yellow wire) at the 16-pin connector. Connect the black (–) probe into pin 1 (white wire). **See previous CAUTION.**
8. With the accelerator pedal fully up (not pressed), the multimeter should indicate between 5.67k ohms and 7.43k ohms.
9. Slowly press the accelerator pedal while monitoring the multimeter. The resistance should drop as the pedal is pressed. When the pedal is all the way to the floor, the multimeter should indicate approximately 1k ohms.
10. If any other reading is observed, check the continuity of the wires in the wire harness.

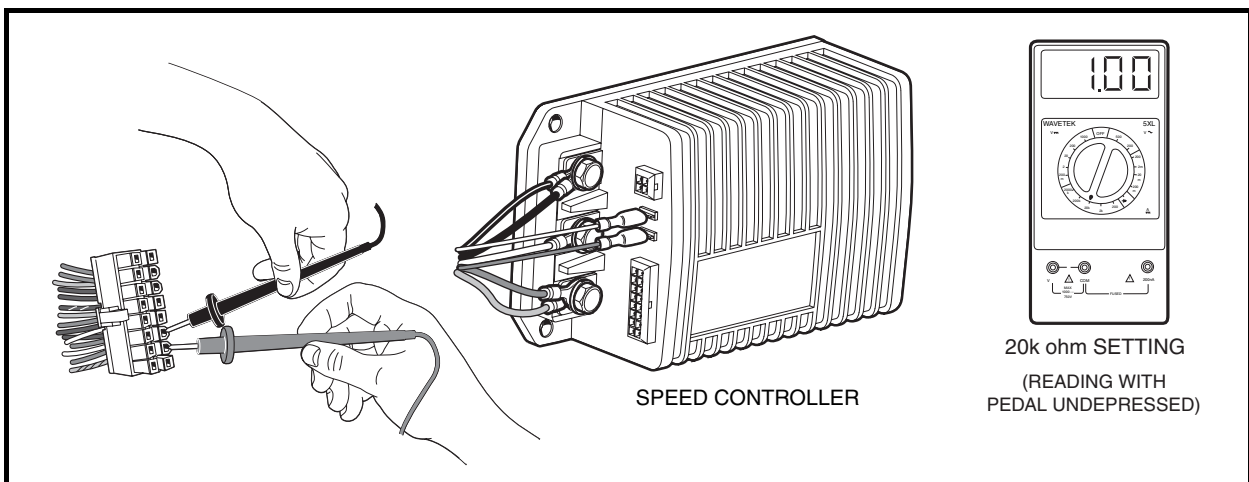

Figure 21-5 Pins 1, 2, and 3 Test

Test Procedure 9B – Pin 5

See General Warning on page 1-1.

Pin 5 in the 16-pin connector provides a connection point for the solenoid lockout circuit from the onboard computer to the speed controller.

1. Disconnect the battery cables as instructed. See **WARNING “To avoid unintentionally starting...”** in **General Warning on page 1-1.**
2. Place chocks at the front wheels and lift the rear of the vehicle with a chain hoist or floor jack. Position jack stands under the frame crossmember between the spring mount and side stringer, just forward of each rear wheel. See **WARNING “Lift only one end...”** in **General Warning on page 1-1.**
3. Disconnect the 16-pin connector at the speed controller.
4. Set a multimeter to 200 volts DC. Insert the red (+) probe of the multimeter into pin 5 (light blue wire) of the 16-pin connector. See following **CAUTION.** Using an alligator clip, connect the black (–) probe to the B– terminal of the speed controller (**Figure 21-6, Page 21-20**).

CAUTION

- Do not fully insert probes into the 16-pin plug. Doing so can result in a poor connection.

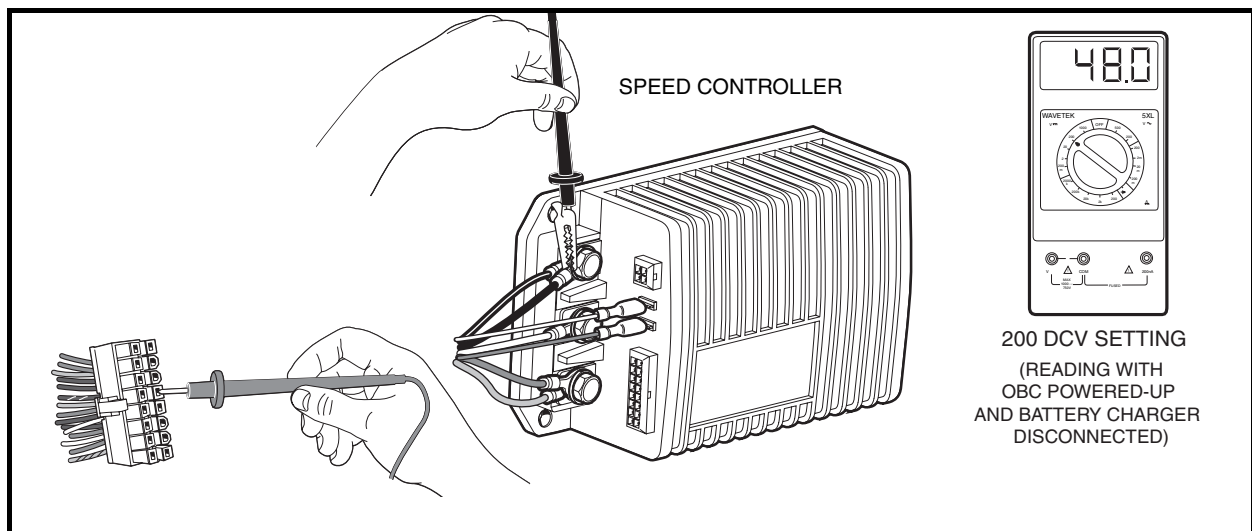

Figure 21-6 Pin 5 Test

5. Place the Tow/Run switch in the TOW position and connect the battery cables, positive (+) cable first. Tighten battery terminals to 110 in-lb (12.4 N·m).
6. Place the Tow/Run switch in the RUN position.
7. The multimeter should indicate zero volts DC at this time.
8. While monitoring the multimeter, plug the battery charger into the vehicle charger receptacle.
9. After a short delay, the onboard computer should power-up (come out of sleep mode), charger relay should click, and the ammeter on the charger should indicate that the vehicle batteries are being charged.
10. The multimeter should indicate zero volts DC while the charger is connected to the vehicle.\
11. While observing the multimeter, disconnect the DC plug from the vehicle charger receptacle.

12. The multimeter should indicate full battery voltage when the charger is not connected to the vehicle.
13. If any other reading is obtained, check the following items:
 - Continuity of the wires in the wire harness
 - Onboard computer for proper operation. **See Test Procedure 11 – Onboard Computer Gray Wire and Fuse on page 21-28.**
 - Tow/Run switch for proper operation. **See Test Procedure 6 – Tow/Run Switch on page 21-15.**

Test Procedure 9C – Pin 6

See General Warning on page 1-1.

Pin 6 in the 16-pin connector provides a connection point for the MCOR limit switch to the speed controller.

1. Disconnect the battery cables as instructed. **See WARNING “To avoid unintentionally starting...” in General Warning on page 1-1.**
2. Place chocks at the front wheels and lift the rear of the vehicle with a chain hoist or floor jack. Position jack stands under the frame crossmember between the spring mount and side stringer, just forward of each rear wheel. **See WARNING “Lift only one end...” in General Warning on page 1-1.**
3. Disconnect the 16-pin connector at the speed controller.
4. Set a multimeter to 200 volts DC, insert the red (+) probe of the multimeter into pin 6 (green wire) of the 16-pin connector. **See following CAUTION.** Using an alligator clip, connect the black (–) probe to the B–terminal of the speed controller (**Figure 21-7, Page 21-21**).

CAUTION

- Do not fully insert probes into the 16-pin plug. Doing so can result in a poor connection.

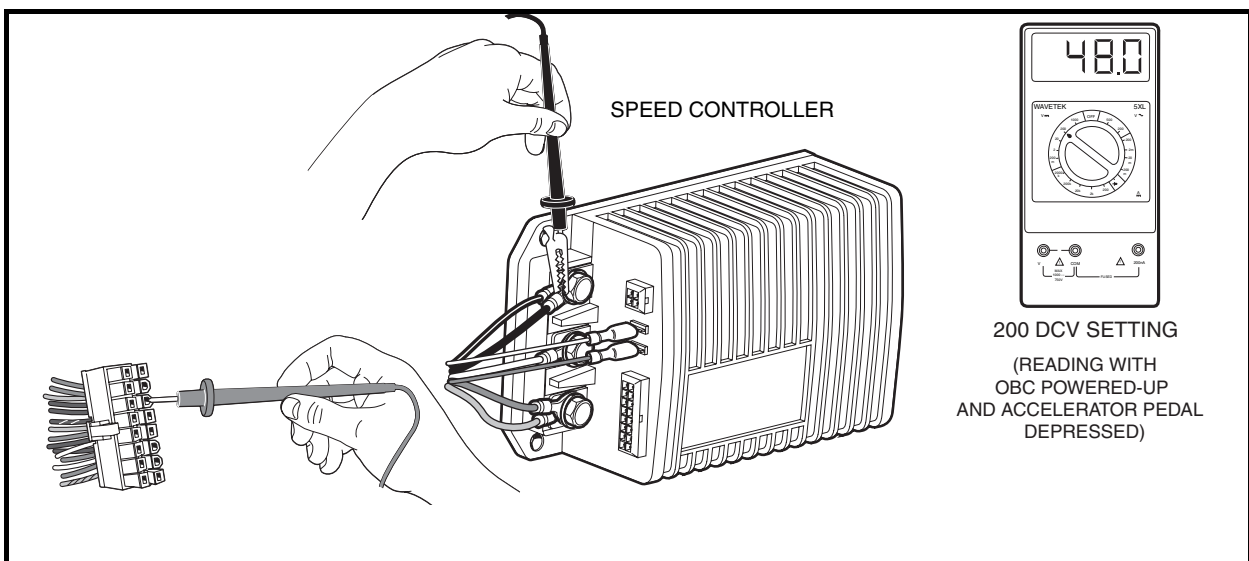

Figure 21-7 Pin 6 Test

5. Place the Tow/Run switch in the TOW position and connect the battery cables, positive (+) cable first. Tighten battery terminals to 110 in-lb (12.4 N·m).
6. Place the Tow/Run switch in the RUN position, key switch in the ON position, and Forward/Reverse switch in the FORWARD position.

7. The multimeter should indicate zero volts DC at this time.
8. While monitoring the multimeter, slowly press the accelerator pedal and hold the pedal at approximately 20% of full travel.
9. After a short delay, the onboard computer should power-up (come out of sleep mode).
10. The multimeter should indicate full battery voltage (approximately 48 volts) when the accelerator pedal is pressed.
11. While observing the multimeter, release the accelerator pedal.
12. The multimeter should indicate zero volts when the accelerator pedal is not pressed.
13. If any other reading is obtained, check the following items:
 - Continuity of the wires in the wire harness
 - Onboard computer for proper operation. **See Test Procedure 11 – Onboard Computer Gray Wire and Fuse on page 21-28.**
 - Tow/Run switch for proper operation. **See Test Procedure 6 – Tow/Run Switch on page 21-15.**
 - Key switch and MCOR limit switch for proper operation. **See Test Procedure 8 – Key Switch and MCOR Limit Switch Circuit on page 21-16.**
 - Ensure that the pedal group is adjusted correctly. **See Pedal Group Adjustment – Electric Vehicles on page 5-16.**

Test Procedure 9D – Pin 7

See General Warning on page 1-1.

Pin 7 in the 16-pin connector provides a connection point for the reverse buzzer to the speed controller.

1. Disconnect the battery cables as instructed. **See WARNING “To avoid unintentionally starting...” in General Warning on page 1-1.**
2. Place chocks at the front wheels and lift the rear of the vehicle with a chain hoist or floor jack. Position jack stands under the frame crossmember between the spring mount and side stringer, just forward of each rear wheel. **See WARNING “Lift only one end...” in General Warning on page 1-1.**
3. Disconnect the 16-pin connector at the speed controller.
4. Place a jumper wire with an alligator clip between the B– terminal of the speed controller (use alligator clip for this connection) and pin 7 (orange/white wire) of the 16-pin connector (**Figure 21-8, Page 21-23**). **See following CAUTION.**

CAUTION

- **Do not fully insert probes into the 16-pin plug. Doing so can result in a poor connection.**
5. Place the Tow/Run switch in the TOW position and connect the battery cables, positive (+) cable first. Tighten battery terminals to 110 in-lb (12.4 N-m).
 6. Place the Tow/Run switch in the RUN position.
 7. The reverse buzzer should sound when the Tow/Run switch is in the RUN position.
 8. If any other activity is observed, check the following items:
 - Continuity of the wires in the wire harness
 - Reverse buzzer for proper operation. **See Test Procedure 16 – Reverse Buzzer on page 21-31.**
 - Tow/Run switch for proper operation. **See Test Procedure 6 – Tow/Run Switch on page 21-15.**

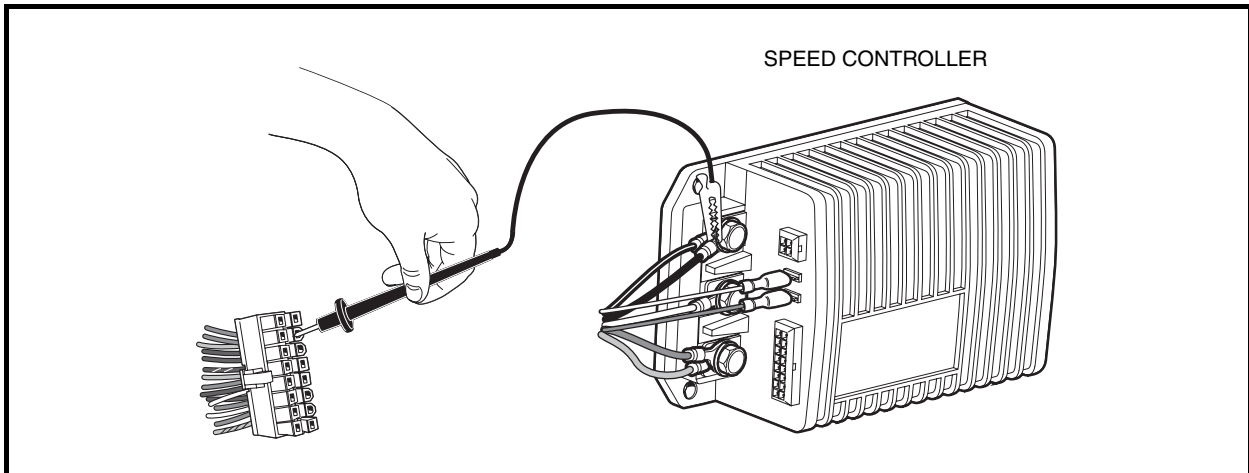

Figure 21-8 Pin 7 Test

Test Procedure 9E – Pins 8 and 16

See **General Warning** on page 1-1.

Pins 8 and 16 in the 16-pin connector provide a connection point for the Forward/Reverse rocker switch to the speed controller. The switch provides a +48 volt signal to the speed controller through pin 8 when the Forward/Reverse switch is in the FORWARD position and provides a +48 volt signal on pin 16 when the Forward/Reverse switch is in the REVERSE position.

1. Disconnect the battery cables as instructed. See **WARNING “To avoid unintentionally starting...”** in **General Warning** on page 1-1.
2. Place chocks at the front wheels and lift the rear of the vehicle with a chain hoist or floor jack. Position jack stands under the frame crossmember between the spring mount and side stringer, just forward of each rear wheel. See **WARNING “Lift only one end...”** in **General Warning** on page 1-2.
3. Disconnect the 16-pin connector at the speed controller.
4. Set a multimeter to 200 volts DC, insert the red (+) probe of the multimeter into pin 8 (brown wire) of the 16-pin connector. See following **CAUTION**. Using an alligator clip, connect the black (–) probe to the B– terminal of the speed controller (**Figure 21-9, Page 21-24**).

CAUTION

- Do not fully insert probes into the 16-pin plug. Doing so can result in a poor connection.

5. Place the Tow/Run switch in the TOW position and connect the battery cables, positive (+) cable first. Tighten battery terminals to 110 in-lb (12.4 N·m).
6. Place the Tow/Run switch in the RUN position and the Forward/Reverse switch in the NEUTRAL position. The multimeter should indicate zero volts DC at this time.
7. While monitoring the multimeter, place the Forward/Reverse switch in the REVERSE position. The multimeter should still indicate zero volts.
8. Place the Forward/Reverse switch in the FORWARD position. The multimeter should indicate full battery voltage (approximately 48 volts).
9. Insert the red (+) probe of the multimeter into pin 16 (blue wire) of the 16-pin connector. Leave the black (–) probe (alligator clip) connected to the B– terminal of the speed controller. See **previous CAUTION**.

10. Place the Forward/Reverse switch in the NEUTRAL position. The multimeter should indicate zero volts DC at this time.
11. While monitoring the multimeter, place the Forward/Reverse switch in the FORWARD position. The multimeter should still indicate zero volts.
12. Place the Forward/Reverse switch in the REVERSE position. The multimeter should indicate full battery voltage (approximately 48 volts).
13. If any other reading is obtained, check the following items:
 - Continuity of the wires in the wire harness
 - Forward/Reverse switch for proper operation. **See Test Procedure 15 – Forward/Reverse Rocker Switch on page 21-30.**
 - Tow/Run switch for proper operation. **See Test Procedure 6 – Tow/Run Switch on page 21-15.**

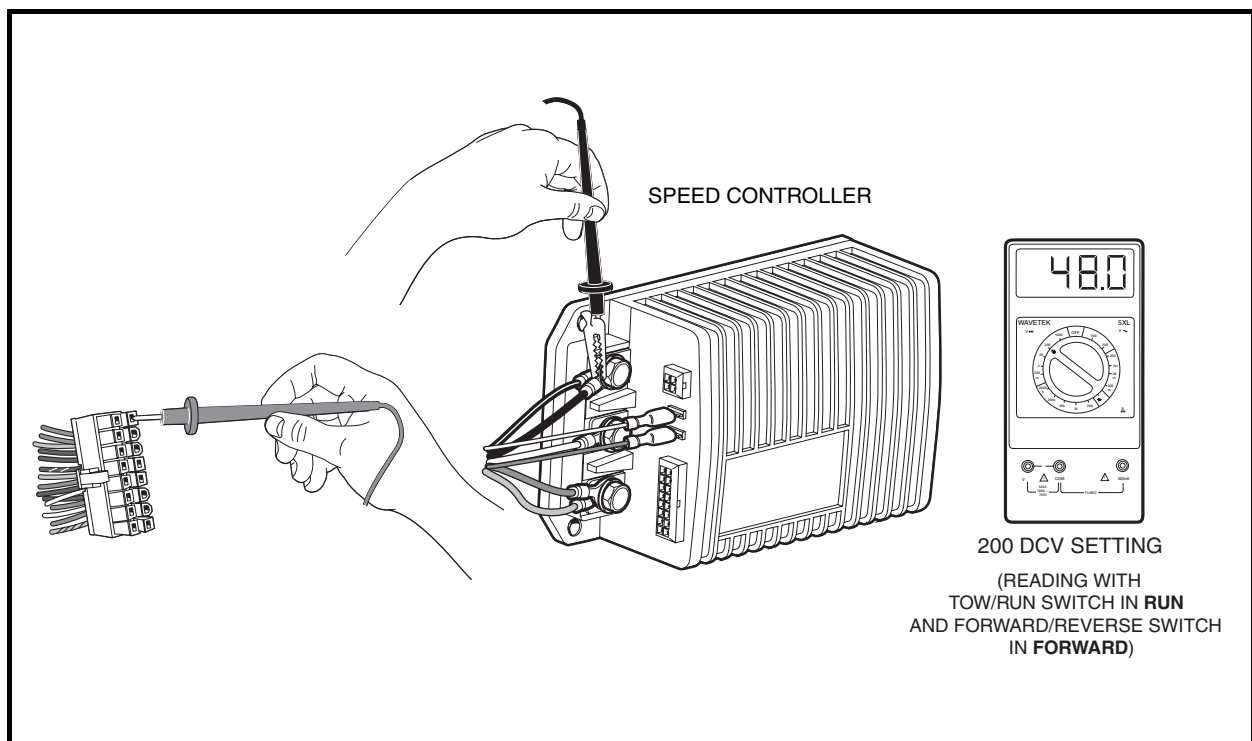

Figure 21-9 Pins 8 and 16 Test

Test Procedure 9F – Pin 9

See General Warning on page 1-1.

Pin 9 in the 16-pin connector provides a connection point for the Tow/Run switch to the speed controller. The switch provides a +48 volt signal to the speed controller through pin 9 when the Tow/Run switch is in the RUN position.

1. Disconnect the battery cables as instructed. **See WARNING “To avoid unintentionally starting...” in General Warning on page 1-1.**
2. Place chocks at the front wheels and lift the rear of the vehicle with a chain hoist or floor jack. Position jack stands under the frame crossmember between the spring mount and side stringer, just forward of each rear wheel. **See WARNING “Lift only one end...” in General Warning on page 1-1.**

3. Disconnect the 16-pin connector at the speed controller.
4. Set a multimeter to 200 volts DC, insert the red (+) probe of the multimeter into pin 9 (gray wire) of the 16-pin connector. **See following CAUTION.** Using an alligator clip, connect the black (-) probe to the B-terminal of the speed controller (**Figure 21-10, Page 21-25**).

CAUTION

- Do not fully insert probes into the 16-pin plug. Doing so can result in a poor connection.
5. Place the Tow/Run switch in the TOW position and connect the battery cables, positive (+) cable first. Tighten battery terminals to 110 in-lb (12.4 N·m).
 6. Place the Tow/Run switch in the RUN position. The multimeter should indicate full battery voltage (approximately 48 volts).
 7. Place the Tow/Run switch in the TOW position. The multimeter should indicate zero volts DC at this time.
 8. If any other reading is obtained, check the following items:
 - Continuity of the wires in the wire harness
 - Tow/Run switch for proper operation. **See Test Procedure 6 – Tow/Run Switch on page 21-15.**

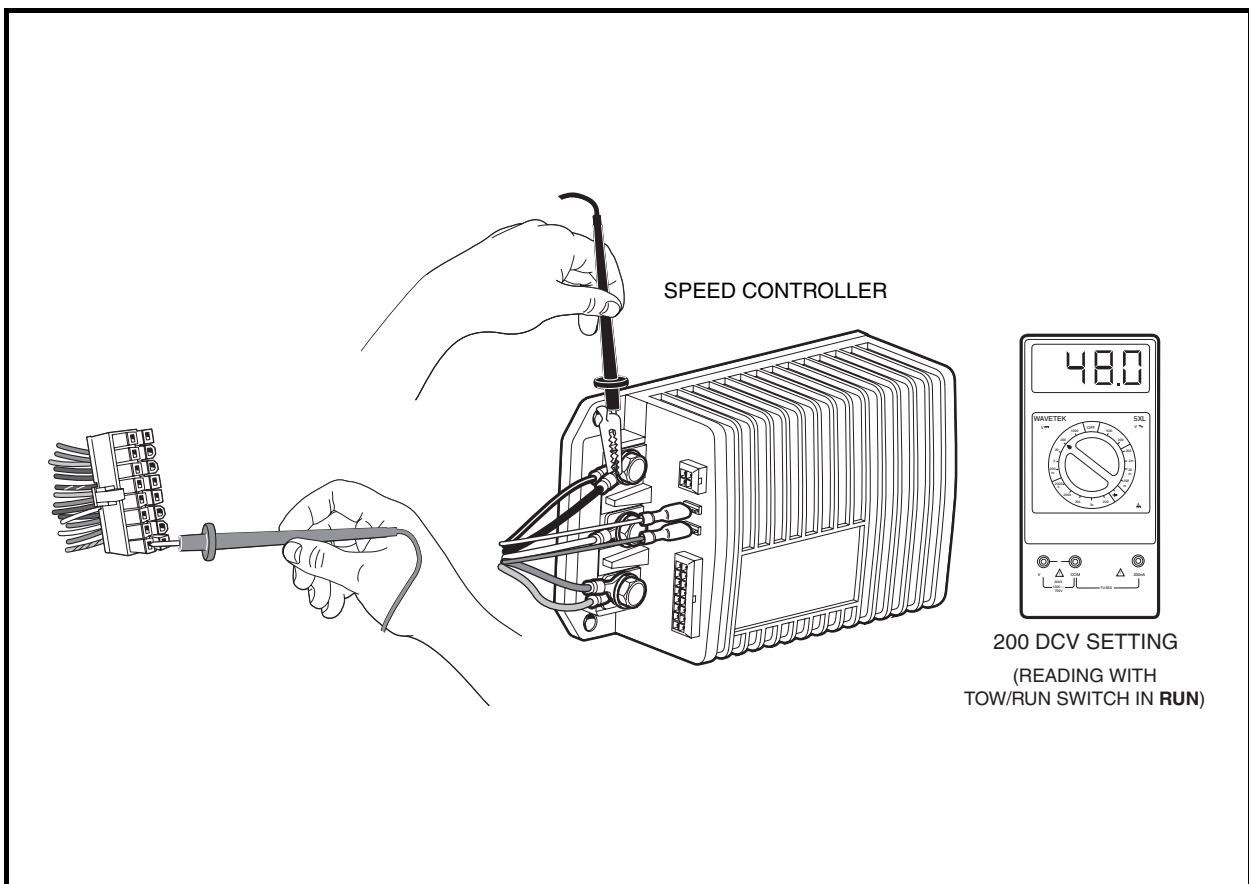

Figure 21-10 Pin 9 Test

Test Procedure 9G – Pin 10

See General Warning on page 1-1.

Pin 10 in the 16-pin connector provides a connection point for the key switch to the speed controller. The key switch provides a +48 volt signal to the speed controller through pin 10 when the key switch is in the ON position.

1. Disconnect the battery cables as instructed. See **WARNING “To avoid unintentionally starting...”** in **General Warning on page 1-1.**
2. Place chocks at the front wheels and lift the rear of the vehicle with a chain hoist or floor jack. Position jack stands under the frame crossmember between the spring mount and side stringer, just forward of each rear wheel. See **WARNING “Lift only one end...”** in **General Warning on page 1-1.**
3. Disconnect the 16-pin connector at the speed controller.
4. With a multimeter set for 200 volts DC, insert the red (+) probe of the multimeter into pin 10 (tan wire) of the 16-pin connector. See following **CAUTION.** With an alligator clip, connect the black (–) probe to the B– terminal of the speed controller (**Figure 21-11, Page 21-26**).

CAUTION

- Do not fully insert probes into the 16-pin plug. Doing so can result in a poor connection.

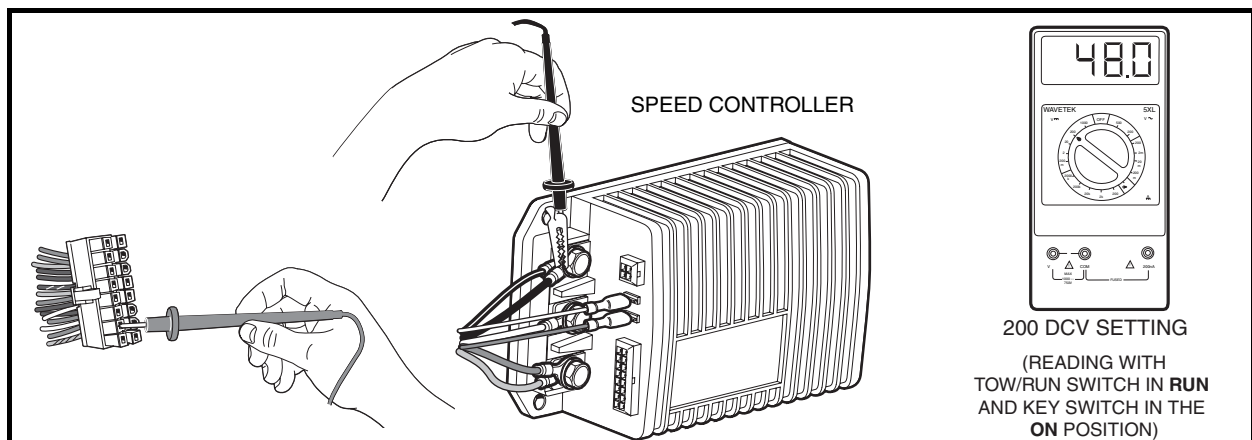

Figure 21-11 Pin 10 Test

5. Place the Tow/Run switch in the TOW position and connect the battery cables, positive (+) cable first. Tighten battery terminals to 110 in-lb (12.4 N·m).
6. With the Tow/Run switch in the TOW position, the multimeter should indicate zero volts.
7. Place the Tow/Run switch in the RUN position and the key switch in the ON position.
8. With the key switch in the ON position, the multimeter should indicate full battery voltage (approximately 48 volts). With the key switch in the OFF position, the reading should be zero volts.
9. If any other reading is obtained, check the following items:
 - Continuity of the wires in the wire harness
 - Tow/Run switch for proper operation. See **Test Procedure 6 – Tow/Run Switch on page 21-15.**
 - Key switch for proper operation. See **Test Procedure 8 – Key Switch and MCOR Limit Switch Circuit on page 21-16.**

Test Procedure 9H – Pin 12

See General Warning on page 1-1.

Pin 12 in the 16-pin connector provides a connection point for the solenoid coil to the speed controller. The speed controller activates the solenoid coil by providing a ground to the solenoid coil at the appropriate time.

1. Disconnect the battery cables as instructed. See **WARNING “To avoid unintentionally starting...”** in **General Warning on page 1-1.**
2. Place chocks at the front wheels and lift the rear of the vehicle with a chain hoist or floor jack. Position jack stands under the frame crossmember between the spring mount and side stringer, just forward of each rear wheel. See **WARNING “Lift only one end...”** in **General Warning on page 1-1.**
3. Disconnect the 16-pin connector at the speed controller.
4. Place a jumper wire with an alligator clip between the B– terminal of the speed controller (use alligator clip for this connection) and pin 12 (blue/white wire) of the 16-pin connector (**Figure 21-12, Page 21-27**). See following **CAUTION.**

CAUTION

- Do not fully insert probes into the 16-pin plug. Doing so can result in a poor connection.
5. Place the Tow/Run switch in the TOW position and connect the battery cables, positive (+) cable first. Tighten battery terminals to 110 in-lb (12.4 N·m).
 6. Place the Tow/Run switch in the RUN position and the key switch in the ON position.
 7. The solenoid should click when the key switch is placed in the ON position.
 8. If any other activity is observed, check the following items:
 - Continuity of the wires in the wire harness.
 - Reverse buzzer for proper operation. See **Test Procedure 16 – Reverse Buzzer on page 21-31.**
 - Tow/Run switch for proper operation. See **Test Procedure 6 – Tow/Run Switch on page 21-15.**
 - Key switch for proper operation. See **Test Procedure 8 – Key Switch and MCOR Limit Switch Circuit on page 21-16.**
 - Solenoid for proper operation. See **Test Procedure 14 – Solenoid Continuity on page 21-30.**

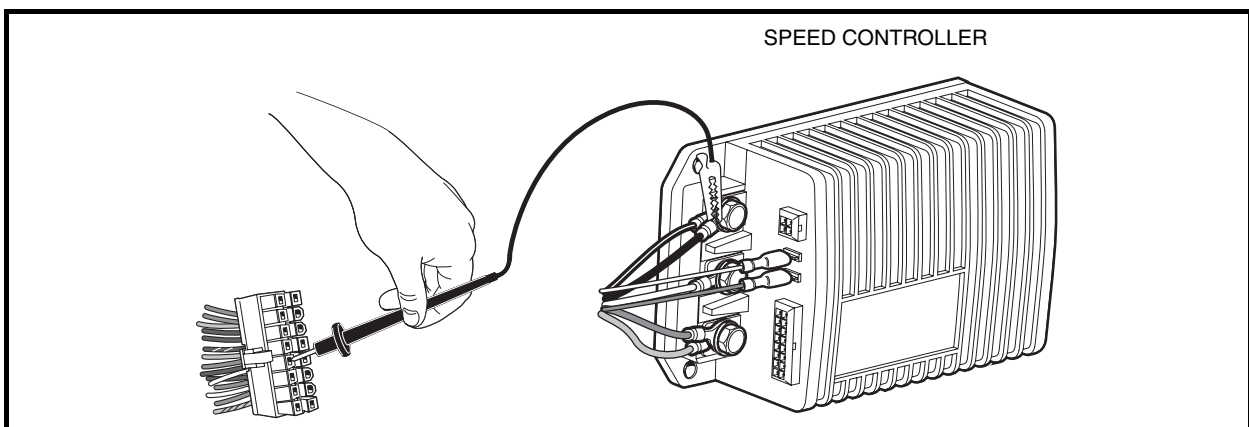

Figure 21-12 Pin 12 Test

TEST PROCEDURE 10 – ONBOARD COMPUTER SILICON-CONTROLLED RECTIFIER (SCR) CIRCUIT

See General Warning on page 1-1.

The silicon controlled rectifier (SCR), located inside the onboard computer, acts as a switch on the negative side of the circuit.

This allows the onboard computer (OBC) to control the battery charging current.

Use the following procedure to test the SCR:

1. With batteries connected and a multimeter set to 200 volts DC, place the red (+) probe on the positive post of battery no. 1 and place the black (–) probe on the charger receptacle fuse terminal that has the black 10-gauge OBC wire attached to it. The reading should be approximately 36–42 volts.
2. If the reading is zero volts, check the black 10-gauge wire connections at the controller and receptacle. Check the continuity of the black 10-gauge wires. If the wires and connections are okay, the SCR has failed. Replace the OBC. If the reading is correct, proceed to the following step.
3. Plug in AC and DC cords. When the battery charger relay clicks on, reading should be approximately 48 volts (full battery voltage). If the reading does not rise from approximately 40 volts to full battery voltage when the DC cord is plugged in and the relay clicks on, check the following items:
 - Charger receptacle fuse and black wire terminal socket in the charger receptacle.
 - Onboard computer gray wire and fuse. **See Test Procedure 11 – Onboard Computer Gray Wire and Fuse on page 21-28.**
 - Red wire at the charger receptacle. **See Test Procedure 12 – Voltage at Charger Receptacle Red Wire Socket on page 21-28.**

TEST PROCEDURE 11 – ONBOARD COMPUTER GRAY WIRE AND FUSE

See General Warning on page 1-1.

1. With batteries connected and a multimeter set to 200 volts DC, connect the red (+) probe to the positive post of battery no. 1 and black (–) probe (with insulation-piercing probe) to gray 16-gauge wire at a point between fuse and receptacle. Reading should be approximately 48 volts. If reading is zero volts, check gray wire fuse and fuse holder for continuity.
2. If the reading in step 1 is 48 volts, plug the DC cord into the vehicle's charger receptacle. The voltage reading should drop to approximately 4.0 volts before the charger relay clicks on.
3. When the charger relay is activated, the reading should rise to approximately 48 volts.
4. If voltage does not drop to approximately 4.0 volts when the DC cord is plugged in and then rise to approximately 48 volts when the charger relay clicks on, the gray wire circuit in the OBC has failed. Replace the OBC.

TEST PROCEDURE 12 – VOLTAGE AT CHARGER RECEPTACLE RED WIRE SOCKET

See General Warning on page 1-1.

1. With batteries connected and a multimeter set to 200 volts DC, place the black (–) probe on the negative post of battery no. 4 and place the red (+) probe on the charger receptacle socket connected to the red 10-gauge wire. The reading should be 48–50 volts (full battery voltage).
2. If the reading is zero volts, check the continuity of the 10-gauge red wire from the positive post of battery no. 1 to the receptacle socket.

TEST PROCEDURE 13 – MOTOR SPEED SENSOR

See General Warning on page 1-1.

Motor Speed Sensor Test with the Diagnostic Handset

⚠ CAUTION

- Perform the following procedure only on a level surface. To avoid injury or property damage, ensure that the path of the vehicle is clear before pushing vehicle.

1. Turn the key switch to the OFF position and place the Forward/Reverse switch in the NEUTRAL position.
2. Connect the handset to the vehicle. See **Plugging the Handset into the Vehicle on page 22-1**.
3. Access the Test menu and select SPEED PULSES by using the SCROLL DISPLAY buttons. The handset should indicate OFF when the vehicle is at rest.
4. While monitoring the handset display screen, slowly push the vehicle a short distance (about 3 feet (1 meter)). The handset should indicate ON for speed sensor pulses while the wheels are in motion.
5. If the handset does not indicate ON while the wheels are in motion, proceed to the following procedure, Motor Speed Sensor Test without the Diagnostic Handset.

Motor Speed Sensor Test without the Diagnostic Handset

1. Turn the key switch to the OFF position and place the Forward/Reverse switch in the NEUTRAL position.
2. With batteries connected, disconnect the three-pin connector at the motor speed sensor.
3. Check voltage at black/white wire:
 - 3.1. Set a multimeter to 200 volts DC. Place the red (+) probe on the battery no. 1 positive post and place the black (–) probe on the black/white wire terminal socket in the three-pin connector. The voltage reading should be 48 to 50 volts (full battery voltage).
 - 3.2. If the reading is zero volts, check the continuity of the black/white wire from the 16-pin connector at the speed controller to the three-pin connector at the motor speed sensor. If the continuity is correct, replace the speed controller.
4. Check voltage at the red motor speed sensor wire:
 - 4.1. With Tow/Run switch in the RUN position and using a multimeter set to 20 volts DC, place the black (–) probe on the battery no. 4 negative post and place red (+) probe on red wire terminal socket in three-pin connector. The voltage reading should be approximately 15-16 volts.
 - 4.2. If the voltage reading is zero volts, check the continuity of the red wire from the 16-pin connector at the speed controller to the three-pin connector at the motor speed sensor. If the wire continuity is correct, replace the speed controller.
 - 4.3. If the reading is below 14 volts, replace the speed controller.
 - 4.4. If the voltage reading is correct, proceed to the following step.
5. Check voltage at the light green wire:
 - 5.1. Set a multimeter to 20 volts DC. Place the black (–) probe on the battery no. 4 negative post and place the red (+) probe on the light green wire female terminal in the three-pin connector at the motor speed sensor. The voltage reading should be from 4.60 to 4.90 volts.
 - 5.2. If the voltage is zero volts, check the continuity of the light green wire from the 16-pin connector at the speed controller to the three-pin connector at the motor speed sensor. If the continuity is correct, replace the speed controller.
 - 5.3. If reading is below 3.50 volts, check the continuity of the wires and plug and replace the speed controller if necessary.

6. Reconnect the three-pin connector at the motor speed sensor. Using a multimeter set to 20 volts DC, place the black (–) probe on the battery no. 4 negative post and place the red (+) probe (with insulation-piercing probe) on the green wire between the three-pin connector and the motor speed sensor.
 - 6.1. Raise one rear wheel off ground. Slowly turn the rear wheel to rotate the motor armature. As the armature rotates, the voltage reading should alternate from zero to approximately 4.85 volts. The voltage reading will fluctuate from zero to 4.85 volts and back to zero four times for each revolution of the motor armature. **See following NOTE.**

NOTE: The voltage reading of 4.85 is an approximate reading. The actual reading may vary from 4.50 to 5.00 volts.

- 6.2. Replace the speed sensor if
 - there is no voltage reading.
 - the voltage reading is not above 3.50.
 - the voltage reading does not fluctuate as the motor is turned.

TEST PROCEDURE 14 – SOLENOID CONTINUITY

See General Warning on page 1-1.

1. Place chocks at the front wheels and lift the rear of the vehicle with a chain hoist or floor jack. Position jack stands under the frame crossmember between the spring mount and side stringer, just forward of each rear wheel. **See WARNING “Lift only one end...” in General Warning on page 1-1.**
2. Disconnect the battery cables as instructed. **See WARNING “To avoid unintentionally starting...” in General Warning on page 1-1.**
3. Disconnect the yellow wire from the large post of the solenoid.
4. Disconnect the resistor terminal from the same large post as the removed wire.
5. Set a multimeter to 200k ohms. Place the black (–) probe on the solenoid large post with the 6-gauge yellow wire and place the red (+) probe on the large post with the 6-gauge red wire. The reading should be no continuity.
6. Connect the 6-gauge yellow wire and resistor to the large solenoid post. Install washer and nut on large solenoid post and tighten to 77 in-lb (8.7 N·m).
7. Place the Tow/Run switch in the TOW position and connect the battery cables, positive (+) cable first. Tighten battery terminals to 110 in-lb (12.4 N·m).
8. Place the Tow/Run switch in the RUN position, turn the key switch to the ON position, place the Forward/Reverse rocker switch in the FORWARD position, and press the accelerator pedal. The solenoid should click and the multimeter should indicate continuity. If the reading is no continuity, replace the solenoid.

TEST PROCEDURE 15 – FORWARD/REVERSE ROCKER SWITCH

See General Warning on page 1-1.

Forward/Reverse Rocker Switch Test with the Diagnostic Handset

1. Turn the key switch to the OFF position and place the Forward/Reverse switch in the NEUTRAL position.
2. Connect the handset to the vehicle. **See Plugging the Handset into the Vehicle on page 22-1.**
3. Test FORWARD INPUT.
 - 3.1. Access the Test menu and select FORWARD INPUT by using the SCROLL DISPLAY buttons. The handset should indicate OFF when the Forward/Reverse switch is in the NEUTRAL or REVERSE position.

- 3.2. Place the Forward/Reverse switch in the FORWARD position. The handset should indicate that FORWARD INPUT is ON. If the handset indicates any other reading, check vehicle wiring. **See Wiring Diagram on page 21-2.** Also check the 16-pin connector at the speed controller. **See Test Procedure 9 – 16-Pin Connector on page 21-18.**
4. Test REVERSE INPUT.
 - 4.1. Access the Test menu and select REVERSE INPUT by using the SCROLL DISPLAY buttons. The handset should indicate OFF when the Forward/Reverse switch is in the NEUTRAL or FORWARD position.
 - 4.2. Place the Forward/Reverse switch in the REVERSE position. The handset should indicate that REVERSE INPUT is ON. If the handset indicates any other reading, check vehicle wiring. **See Wiring Diagram on page 21-2.** Also check the 16-pin connector at the speed controller. **See Test Procedure 9 – 16-Pin Connector on page 21-18.**
5. If the handset displays readings other than those described above and the wiring is found to be correct, proceed to the following procedure, Forward/Reverse Rocker Switch Test without the Diagnostic Handset.

Forward/Reverse Rocker Switch Test without the Diagnostic Handset

1. Disconnect the battery cables as instructed. **See WARNING “To avoid unintentionally starting...” in General Warning on page 1-1.**
2. Remove the rocker switch from the vehicle. **See Section 23 – Electrical Components: Electric Vehicle.**
3. Disconnect the three wires from the rocker switch. Using a multimeter set to 200 ohms, place the black (–) probe on the blue wire terminal 3 position on the rocker switch, and place the red (+) probe on the orange wire terminal 2 position. With the switch in NEUTRAL or REVERSE, there should be no continuity. With the switch in FORWARD, there should be continuity. If the readings are incorrect, replace the switch.
4. Place the black (–) probe on the brown wire terminal 1 position on the rocker switch and place the red (+) probe on the orange wire terminal. With the switch in REVERSE, there should be continuity. If the readings are incorrect, replace the switch.

TEST PROCEDURE 16 – REVERSE BUZZER

See General Warning on page 1-1.

1. Disconnect the battery cables as instructed. **See WARNING “To avoid unintentionally starting...” in General Warning on page 1-1.**
2. Remove the instrument panel.
 - 2.1. Loosen seven Tuflok screws, but do not remove screws completely, as shown in Detail A. **See Figure 23-1, Page 23-2.**
 - 2.2. Remove Tuflok screws from instrument panel as shown in Detail B.
 - 2.3. Pull forward on top of instrument panel.
3. Disconnect the 18-gauge red and orange/white wires from the reverse buzzer.
4. Place the Tow/Run switch in the TOW position and connect the battery cables, positive (+) cable first. Tighten battery terminals to 110 in-lb (12.4 N·m).
5. Place the Tow/Run switch in the RUN position.
6. Set a multimeter to 200 volts DC. Place the black (–) probe on battery no. 4 negative post and place the red (+) probe on the red wire terminal end that was disconnected from the reverse buzzer. The reading should be approximately 48 volts (full battery voltage).

- 6.1. If the voltage reading is correct, proceed to step 7.
- 6.2. If reading is zero volts, check red wire continuity and Tow/Run switch. **See Test Procedure 2 – Onboard Computer Solenoid Lockout Circuit on page 21-11. See also Test Procedure 6 – Tow/Run Switch on page 21-15.**
- 6.3. If the continuity readings are not correct, repair or replace the red wire.
- 6.4. If the continuity readings are correct, proceed to step 7.
7. Place the Forward/Reverse switch in REVERSE. Using a multimeter set to 200 volts DC, place the black (–) probe on the orange/white wire terminal end (that was disconnected from the reverse buzzer) and place the red (+) probe on battery no. 1 positive post. The reading should be approximately 48 volts (full battery voltage).
 - 7.1. If the voltage reading is correct, replace the reverse buzzer.
 - 7.2. If reading is zero volts, check orange/white wire continuity and connection at Pin 10 in 23-Pin connector.
 - 7.3. If there is no continuity in the orange/white wire, or the Pin 10 terminal in the 23-Pin connector is not properly seated, repair or replace as required.
 - 7.4. If the orange/white wire continuity and 23-Pin connector are correct and there is no voltage at the orange wire, replace the controller.

TEST PROCEDURE 17 – REBOOTING THE ONBOARD COMPUTER

See General Warning on page 1-1.

It is possible the Onboard Computer (OBC) can become “locked up,” causing the OBC solenoid lockout circuit to malfunction. If this condition is suspected, restart the computer as follows:

1. Disconnect the battery cables as instructed. **See WARNING “To avoid unintentionally starting...” in General Warning on page 1-1. See following NOTE.**

NOTE: Wait at least 90 seconds for the capacitors in the speed controller to discharge. The capacitors in the speed controller must be fully discharged in order to reboot the OBC.

2. Place the Tow/Run switch in the TOW position and connect the battery cables, positive (+) cable first. Tighten battery terminals to 110 in-lb (12.4 N·m) and coat terminals with Battery Terminal Protector Spray (CCI P/N 1014305) to minimize corrosion.
3. Place Tow/Run switch in the RUN position.
4. Test drive the vehicle. If the problem has been fixed, the vehicle will function normally. If the problem still exists, refer to Wiring Diagram on page 21-2.

TEST PROCEDURE 18 – BATTERY WARNING LIGHT

See General Warning on page 1-1.

1. Reboot the OBC and drive the vehicle a short distance. When vehicle is first driven, the battery warning light should illuminate for 10 seconds. **See Test Procedure 17 – Rebooting the Onboard Computer on page 21-32.** If the battery warning light does not illuminate when rebooting the OBC, proceed to step 2.
2. Turn key switch OFF, place Tow/Run switch in TOW and place Forward/Reverse rocker switch in NEUTRAL.
3. Disconnect the six-pin connector at the OBC.
4. Remove the wedge lock from the six-pin connector housing that is connected to the vehicle wire harness. Remove the brown/white wire from the connector plug.

5. Use a jumper wire with an alligator clip at each end and connect one alligator clip to the negative post of battery no. 1 and the other alligator clip to the brown/white wire terminal socket that was removed from the six-pin connector plug.
6. Install the wedgelock in the six-pin connector housing and reconnect the six-pin connector plug. Place the Tow/Run switch in the RUN position and the battery light should illuminate. If the light does not illuminate, replace the battery warning light assembly.

COMMUNICATION DISPLAY MODULE (CDM)

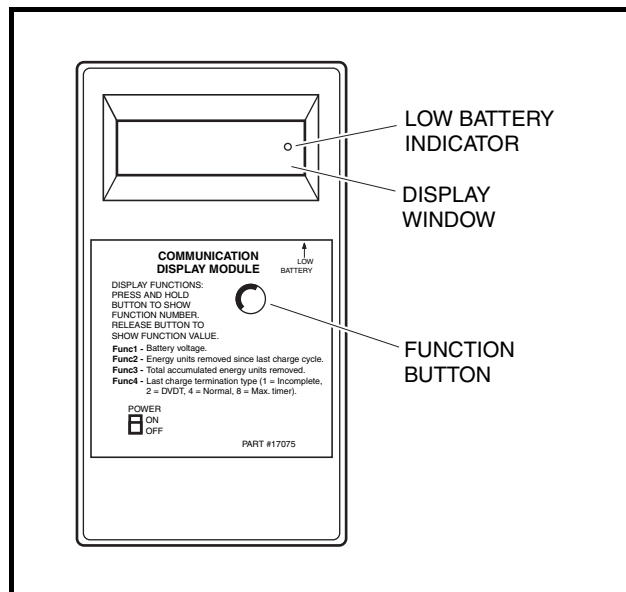

Figure 21-13 CDM

The CDM can be used to retrieve from the onboard computer four important items of information that can be useful in troubleshooting the electric vehicle. To access one of these items, the item's corresponding Function Code must be selected on the CDM. This is done by pressing the Function Button until the desired function code is displayed in the window. **See Figure 21-13, Page 21-33 for CDM features.** Releasing the button when the desired code is displayed will display the data. Function codes and corresponding data are as follows:

- **F1 – Battery voltage:**

This displays the battery pack's current state of charge. A reading of less than 48 volts indicates that the batteries need to be charged. If a reading of less than 48 volts is obtained immediately after a charge cycle, there may be a problem in the charge circuit.

- **F2 – Energy units removed since last charge cycle:**

If the display reads over 75 (the vehicle battery warning light should be illuminated), the vehicle batteries need to be recharged before being used again. This data can be used to make sure all vehicles in a fleet receive equal usage on a short-term basis.

- **F3 – Total accumulated energy units removed since initial vehicle start-up:**

This information is most useful in making sure that all vehicles in a fleet receive equal usage over long periods of time.

- **F4 – Last charge termination type (1 = incomplete, 2 = DVDT, 4 = normal, 8 = max. timer):**

A 1, 2, 4, or 8 will be displayed.

1 – Indicates the last charge cycle was incomplete and the batteries were not fully charged. Batteries should be charged again at the earliest opportunity.

2 – Indicates a back-up charge program was employed by the OBC to complete the charge cycle. A DVDT charge may be displayed the first few times a new set of batteries is charged, and the first time a set of batteries is charged after the batteries have been disconnected and reconnected. A problem may exist if persistent DVDT readings are obtained.

4 – Indicates the last charge cycle was normal.

8 – Indicates the charger ran for sixteen hours and shut itself off without completing the charge cycle. This means there may be a problem in the charge circuit.

The CDM also has a low battery indicator, which illuminates when CDM batteries are weak and need to be replaced. Weak batteries in the CDM may cause the CDM to register inaccurate information or no information.

USING THE CDM TO RETRIEVE DATA FROM THE ONBOARD COMPUTER

1. Turn the CDM ON.
2. Position CDM on seat bottom so it is aligned directly with the battery warning light. Ensure CDM infrared LED receiver is pointed at battery warning light and there is a clear path between them. **See following NOTE.**

NOTE: *If, by positioning CDM on seat bottom, the CDM is unable to collect the data stream from the onboard computer, hold CDM approximately 6 inches (15.2 cm) from battery warning light.*

3. Wait approximately 30 seconds for a value to appear in the display window.
4. If a value does not appear in the display window after 30 seconds, try adjusting the aim of the CDM and repeating step 3 until a value appears. If there is still no reading, check for weak batteries in the CDM.
 - 4.1. Adjust aim of CDM.
 - 4.2. Drive vehicle a short distance to ensure OBC is not in powerdown mode.
 - 4.3. Check for weak batteries in CDM.
 - 4.4. If reading is still not obtained, go to the CDM Troubleshooting Guide on page 21-35.

Once a value has been obtained in the display window, the CDM may be removed from its receiving position and the data reviewed. The CDM will hold the values for F1, F2, F3, and F4 until the CDM is turned OFF or it receives another line of data from the same or another onboard computer. Use the following procedure to review the data stored in the CDM:

- The value currently displayed will be F1 (battery voltage). **See following NOTE.**
- To view F2, press and hold the button on the CDM. When “Func 2” appears in the display window, release the button. The value for F2 will then be displayed.
- To view F3, press and hold the button on the CDM until “Func 3” appears in the display window. Release the button. The value for F3 will be displayed.
- To view F4, press and hold the button on the CDM until “Func 4” appears in the display window. Release the button. The value for F4 will be displayed.

NOTE: *The values of all four functions can be recalled by pressing and releasing the CDM button.*

CDM TROUBLESHOOTING GUIDE

Use the following chart as a starting point for troubleshooting problems with communication between the CDM and onboard computer. Contact your nearest distributor/dealer representative for more comprehensive information.

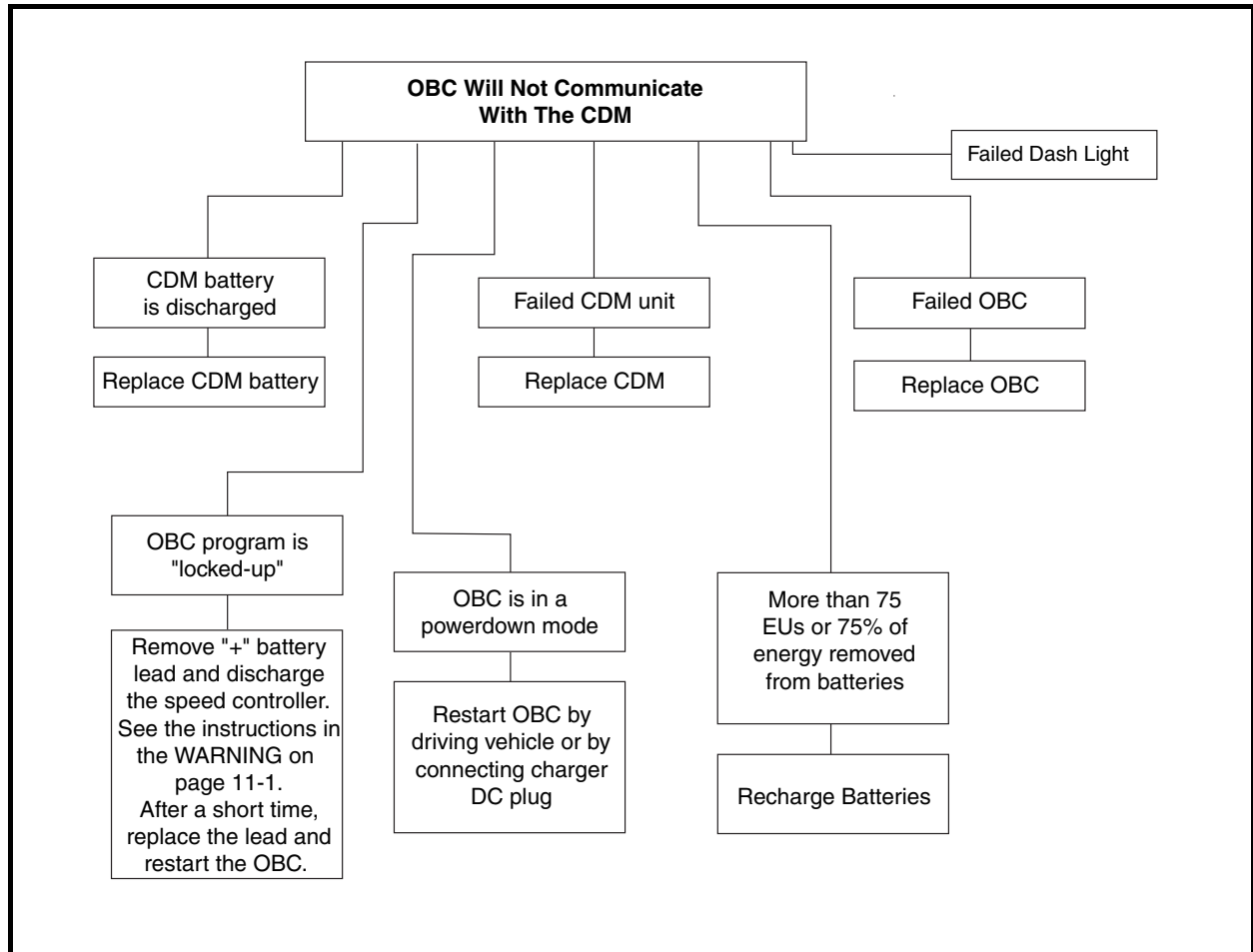

Figure 21-14 Flow Chart – CDM Troubleshooting Guide

SECTION 22 – IQ DISPLAY MODULE (IQDM) AND IQDM-P DIAGNOSTICS

⚠ DANGER

- See General Warning on page 1-1.

⚠ WARNING

- See General Warning on page 1-1.

NOTE: For information specific to the IQDM-P programming features, See Section 29 – IQ DISPLAY MODULE (IQDM-P) Programming.

PLUGGING THE HANDSET INTO THE VEHICLE

1. Connect one end of the cable to the jack located on the bottom of the handset.
2. Connect the cable adaptor to the IQDM cable.
3. Find the IQDM jack on the vehicle (**Figure 22-1, Page 22-1 or Figure 22-2, Page 22-1**).
4. Remove the dust cap from the IQDM jack.
5. Align the keyed portion of the plug with the IQDM jack and connect the plug to the jack.

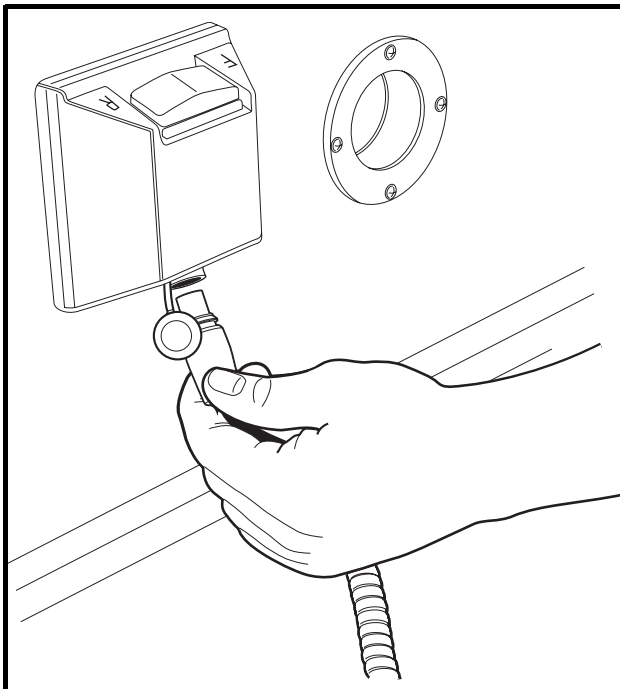

Figure 22-1 IQDM Jack On F&R Switch Housing

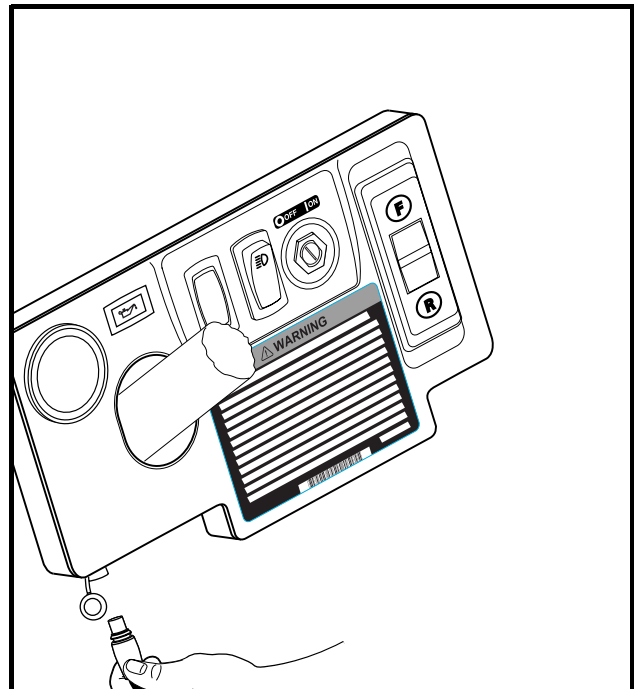

Figure 22-2 IQDM Jack Under Instrument Panel

INTRODUCTORY DISPLAY

Immediately after the handset is connected to the vehicle, it begins loading the vehicle speed controller information. After a few seconds, the screen displays the following menu items:

- Program (IQDM-P only)
- Monitor
- Faults
- Functions
- Information
- Programmer Setup

In the event that the handset does not display any information, or the screen is difficult to read, refer to the IQDM troubleshooting procedures. **See IQDM and IQDM-P Handset Troubleshooting on page 22-16.**

MENU NAVIGATION

The NAVIGATION BUTTON is the four-arrow button located on the left side of the handset (**Figure 22-3, Page 22-3**). This button is used to navigate through and select menus. Pressing the up or down arrows allows the user to scroll through the menu items. When the box beside the desired menu is blinking, pressing the right arrow selects that menu item. Pressing the left arrow allows the user to go back one screen.

The CHANGE VALUE BUTTON is the button located on the right side of the handset (**Figure 22-3, Page 22-3**). This button allows the user to change values by pressing + or –.

The three yellow buttons labeled 1, 2 and 3 are BOOKMARK BUTTONS (**Figure 22-3, Page 22-3**). These buttons allow the user to bookmark up to three specific screens for rapid return to those screens. To bookmark a specific display screen, have the desired screen displayed and simply press and hold a bookmark button until the statement “bookmark set” is displayed. When it is necessary to go back to the bookmarked screen, rapidly press and release the appropriate bookmark button. **See following NOTE.**

NOTE: *When going to a bookmarked display screen, be sure to rapidly press and release the button. If the button is pressed and held for too long, the bookmark will be overridden with the current screen.*

The following menus are accessible on the IQDM handset:

Program (IQDM-P only)

The *program* menu allows the user to view and change custom speed controller settings. **See Program Menu on page 29-2.**

Monitor

The *monitor* menu displays values for certain parameters to facilitate speed controller troubleshooting. **See Monitor Menu on page 22-4.**

Faults

The *faults* menu displays all faults recorded by the speed controller since the history was last cleared. Each fault is listed only once under the history menu, even if the fault has occurred multiple times. **See Faults Menu on page 22-6.** Each fault is listed at the bottom of the monitor menu. The right hand column lists the number of occurrences for each fault. The number of occurrences is reset to zero each time the fault history is cleared.

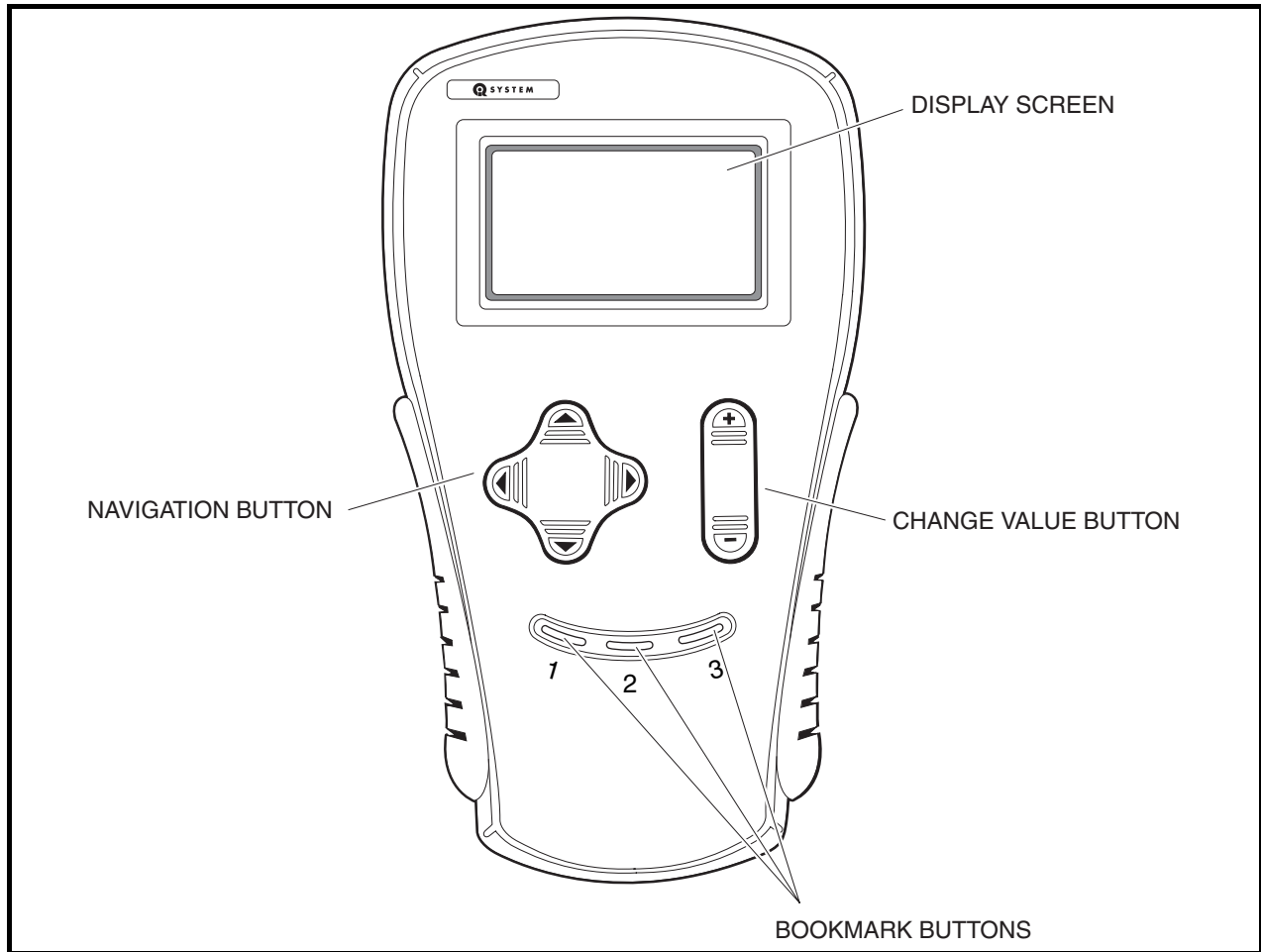

Figure 22-3 Handset Controls

Functions

The *functions* menu allows the user to transfer all current settings from the speed controller to the handset and from the handset to the speed controller. **See Functions Menu on page 22-11.**

Information

The *information* menu displays the model number, serial number, manufacturer date and software version of the speed controller. **See Information on page 22-14.**

Programmer Setup

The *programmer setup* menu allows the user to set the LCD contrast, display the fault history of the programmer as well as various other information pertaining to the handset such as model number, serial number, OEM information, etc. **See Programmer Setup on page 22-14.**

MONITOR MENU

The *monitor* menu is accessed by using the up or down arrow to scroll to *monitor* and pressing the right arrow key to activate the menu. All information in the *monitor* menu is updated in real time, allowing the trained technician to troubleshoot the vehicle by monitoring the handset as the key switch is cycled, Forward/Reverse switch is activated, etc.

Since the *monitor* menu is updated while the vehicle is in operation, the trained technician has the ability to monitor the status of several components in conditions or locations where a problem with vehicle performance has been reported. **See following WARNING.**

WARNING

- **The vehicle operator should not monitor the handset while the vehicle is in motion. A technician can monitor the handset while traveling as a passenger in the vehicle. Failure to heed this warning could result in severe personal injury or death.**

The following parameters can be monitored in real time with the handset from the *monitor* menu:

Throttle

Indicates the position of the accelerator pedal from 0% (pedal not pressed) to 95 - 100% (pedal fully pressed). This item can be monitored when the key switch is in the ON or OFF position.

Batt Voltage

Displays the current battery voltage at the speed controller.

Heatsink

Displays the temperature (in degrees Celsius) of the speed controller heatsink. During normal operating conditions, the heatsink temperature should be below 85 °C ±5 °C (185 °F ±9 °F). **See following NOTE.**

***NOTE:** Improper brake adjustment can sometimes cause the operating current to be higher than normal. This higher current increases the temperature of the speed controller heatsink.*

Arm Current

Displays the motor armature current (in amperes).

Field Current

Displays the motor field current (in amperes).

Arm PWM

Displays motor armature PWM (pulse width modulation). The range of pulse width modulation is 0% to 100%. When the vehicle is operating at full speed, the pulse width modulation should be at 100%.

Field PWM

Displays motor field PWM (pulse width modulation). The range of pulse width modulation is 0% to 100%. When the vehicle is in operation, the pulse width modulation will fluctuate in response to the terrain and throttle input.

Speed Pulses

The *speed pulses* menu item displays the activity of the motor speed sensor. With the key switch in the OFF position, the Forward/Reverse switch in the NEUTRAL position, and the vehicle at rest, the handset should indicate that speed pulses are off. When the vehicle is gently pushed a short distance, the handset should indicate that speed pulses are on.

Foot Input

Indicates the status of the MCOR (motor controller output regulator) internal limit switch: on or off. When the accelerator pedal is unpressed, the handset should indicate that the limit switch is off. When the accelerator pedal is pressed and the key switch is in the ON position, the display should indicate that the limit switch is on.

Forward Input

With the Forward/Reverse switch in the NEUTRAL or REVERSE position, the handset should indicate that the forward input is off. When the Forward/Reverse switch is placed in the FORWARD position, the handset should indicate that the forward input is on.

Reverse Input

With the Forward/Reverse switch in the NEUTRAL or FORWARD position, the handset should indicate that the reverse input is off. When the Forward/Reverse switch is placed in the REVERSE position, the handset should indicate that the reverse input is on.

Main Cont

Displays the current solenoid (main contactor) state. When the contactor is activated, the handset indicates that the solenoid is on. When the contactor is not activated, the handset indicates that the solenoid is off.

Key Input

Displays the position of the key switch: OFF or ON.

Password Tries (IQDM-P only)

A password is required to place the vehicle in "private speed mode" (speed setting 4). The speed controller will log unsuccessful and unauthorized attempts to place the speed controller in "private speed mode." If repeated attempts are unsuccessful, the speed controller will permanently lock out access to "private speed mode." In the event that "private speed mode" is locked out, the controller must be removed and shipped to Club Car before it can ever be placed in "private speed mode." **See Code A, Code B, and Code C on page 29-3.**

10.3 Transaxle

This menu is reserved for possible future use and has no application at this time.

20+ Speed

This menu is reserved for possible future use and has no application at this time.

FAULTS MENU

The *faults* menu is accessed by using the up or down arrow to scroll to *faults* and pressing the right arrow key to activate the menu.

Faults displayed in the *faults* menu will aid the trained technician in troubleshooting the vehicle. Faults displayed often indicate which components in the electrical system need to be tested.

Since the *faults* menu is updated while the vehicle is in operation, the trained technician has the ability to monitor the occurrence of faults in conditions or locations where a problem with vehicle performance has been reported. **See following Warning.**

WARNING

- The vehicle operator should not monitor the handset while the vehicle is in motion. A technician can monitor the handset while traveling as a passenger in the vehicle. Failure to heed this warning could result in severe personal injury or death.

SYSTEM FAULTS

The *system faults* menu displays all of the faults detected by the speed controller since the last time the fault history has been cleared. The faults displayed in this menu may or may not be currently active. Once a fault has been detected, it is stored in the memory of the speed controller for display on the *fault history* menu. Each detected fault is listed only once, but the number of occurrences may be accessed in the monitor menu.

Causes of Faults

Some common causes of faults are:

- Loose, broken, or disconnected wires or connectors
- Failed components
- Improper adjustment or installation of electrical or mechanical components (examples: brake adjustment, improper MCOR installation)
- Improper wiring of electrical components

As shown above, there are many possible causes for faults to occur, and the speed controller has a programmed reaction to each fault that is based on the fault currently detected. The technician should be familiar with the detected faults and the controller's reactions to faults to ensure a proper diagnosis.

An example of a possible mis-diagnosis of a vehicle due to a fault: If the three-pin speed sensor wire has been disconnected, the speed controller will detect a *speed sensor* fault. When a *speed sensor* fault is detected, the controller responds to the fault by limiting the vehicle speed to 1/2 of its normal top speed. If the technician reaches the conclusion that the vehicle is running slowly because batteries are heavily discharged, he has made an improper diagnosis of the problem.

The vehicle speed controller should be checked for fault codes before any service is performed.

The speed controller, after detecting a fault, will respond in one or more of the following ways:

- A. Reduce vehicle speed to zero by reducing armature current
- B. Reduce vehicle speed to zero by reducing field current to zero
- C. Turn off the solenoid
- D. Cause the vehicle to run at half speed
- E. Gradually reduce the armature current limit
- F. Quickly reduce the armature current until speed sensor pulses occur
- G. Reduce field current and beep reverse buzzer at a fast rate

CONTROLLER FAULT	CONTROLLER RESPONSE
HW FAILSAFE	A, B, C
THROTTLE FAULT 1	A
SPEED SENSOR	D
MAIN WELDED	D
MAIN DRIVER ON	D
MAIN DRIVER OFF	A, C
MAIN CONT DNC	B
MAIN COIL FAULT	A
FIELD MISSING	A, B, C
HPD	A
PROC/WIRING	A
OVERVOLTAGE	A, B, G
UNDERVOLTAGE	E
THERMAL CUTBACK	E
MOTOR STALL	F
MAIN DROPOUT	A, C
OPEN ARMATURE	A
MAX PASSWORD TRIES	(no action taken)
INCORRECT PASSWORD	(no action taken)
HIGH SPEED WALKAWAY	D
KEY SWITCH SRO	C

Fault Recovery

When a fault is detected by the speed controller, the speed controller will attempt to recover from the fault and resume normal operation. In the case of an intermittent problem such as a loose wiring connection, the controller **may** be able to recover and operate normally for a while, but the problem should be repaired before placing the vehicle in service.

Depending on the type of fault, the controller will attempt to recover immediately after the condition clears or after the accelerator pedal has been cycled (released and pressed again).

CONTROLLER FAULT	CONTROLLER ATTEMPTS TO RECOVER
HW FAILSAFE	When key switch is cycled
THROTTLE FAULT 1	When condition clears
SPEED SENSOR	When condition clears
MAIN WELDED	When condition clears
MAIN DRIVER ON	When condition clears
MAIN DRIVER OFF	When accel. pedal is cycled
MAIN CONT DNC	When accel. pedal is cycled
MAIN COIL FAULT	When accel. pedal is cycled
FIELD MISSING	When accel. pedal is cycled
HPD	When accel. pedal is cycled
PROC/WIRING	When condition clears
OVERVOLTAGE	When condition clears
UNDERVOLTAGE	When condition clears
THERMAL CUTBACK	When condition clears
MOTOR STALL	When condition clears
MAIN DROPOUT	When accel. pedal is cycled
OPEN ARMATURE	When condition clears and accel. pedal is cycled
MAX PASSWORD TRIES	When Tow/Run switch is cycled
INCORRECT PASSWORD	When Tow/Run switch is cycled
HIGH SPEED WALKAWAY	When Tow/Run switch is cycled
KEY SWITCH SRO	When Key Switch is cycled

The following faults can be detected by the IQ System controller:

HW Failsafe

The armature drive FET's (field effect transistors) regulate the armature current. If the speed controller detects a failure of the armature drive FET's or circuitry, a *hardware failsafe* fault is detected.

Throttle Fault 1

If the MCOR (Motor Controller Output Regulator) voltage is less than 0.20 volts or greater than 4.80 volts, the controller detects a *throttle fault*.

Speed sensor

If the speed controller does not detect pulses from the speed sensor while the controller outputs power (greater than 75% armature PWM) to the motor, a *speed sensor* fault is detected.

Main Welded

If the speed controller detects that the solenoid contacts are welded closed, a *main welded* fault is detected.

Main Driver On

If the FET that controls the closing of the solenoid contacts is found to be energized when it should not be, a *main driver on* fault is detected by the speed controller.

Main Driver Off

If the FET that controls the closing of the solenoid is **not** energized when it should be, a *main driver off* fault is detected by the speed controller.

Key Switch SRO

If the key switch is in the ON position when the controller powers up, a KSI SRO fault will be detected. The KSI SRO fault detection feature can be turned on or off with an IQDM-P.

Main Cont DNC

The *main cont dnc* (main contactor (solenoid) did not close) fault is detected when the speed controller has sent voltage to the solenoid activating coil but the solenoid contacts are not closed.

Main Coil FAULT

If the speed controller determines that the solenoid is not closing as a result of a solenoid coil failure, a *main coil fault* is detected.

Field Missing

If the speed controller is operating at a duty cycle of greater than 90% (almost full speed) and the field current is less than 3 amps, a *field missing* fault is detected by the speed controller.

HPD

The *HPD* (High Pedal Detect) fault is detected if the accelerator pedal is already depressed when the key switch is turned to the ON position. This fault is also detected if the accelerator pedal is pressed when the selected direction is changed by pressing the Forward/Reverse switch. This fault, when not caused by the operator, can indicate that the pedal limit switch has failed closed.

Proc/Wiring

This fault is detected if the Forward/Reverse switch is giving a signal to place the controller in forward and reverse at the same time. This rare fault can be caused by a failed Forward/Reverse switch or improper vehicle wiring.

High Speed Walkaway

If the key switch is turned off while going downhill at high speed, a High Speed WalkAway fault is detected.

Overvoltage

If the speed controller detects that the battery voltage is too high (68.4 to 75.6 volts DC), the *overvoltage* fault is detected.

Undervoltage

If the battery voltage falls below 34 volts $\pm 5\%$, the *low battery voltage* fault is detected by the speed controller.

Thermal Cutback

If the controller heatsink temperature is found to be in excess of $85\text{ }^{\circ}\text{C} \pm 5\text{ }^{\circ}\text{C}$ ($185\text{ }^{\circ}\text{F} \pm 9\text{ }^{\circ}\text{F}$) or below $-25\text{ }^{\circ}\text{C} \pm 5\text{ }^{\circ}\text{C}$ ($-13\text{ }^{\circ}\text{F} \pm 9\text{ }^{\circ}\text{F}$), the *thermal cutback* fault is detected.

Motor Stall

If the motor current is high and there is no movement of the vehicle wheels for a short period of time, a *motor stall* is detected by the speed controller. This fault can be caused by an operator holding the vehicle on a hill by depressing the accelerator pedal instead of the brake pedal.

Main Dropout

If the controller detects that the solenoid contacts have opened while the vehicle is in operation, a *main drop-out* fault is detected.

Open Armature

If the accelerator pedal is pressed 2/3 to the floor, the armature current is less than 20 amps, and there are no speed sensor pulses, an *open armature* fault is detected.

Incorrect Password (IQDM-P only)

Each vehicle has a password in the form of a unique set of codes used to place the vehicle in “private speed mode”. If a set of codes has been entered incorrectly, the *incorrect password* fault is declared. For additional information on codes, refer to Code A, Code B, and Code C. **See Code A, Code B, and Code C on page 29-3. See also Password Tries (IQDM-P only) on page 22-5.**

Max Password Tries (IQDM-P only)

The *max password tries* fault is declared when the incorrect password fault has been declared several times. In the event that the *max password tries* fault is indicated, the speed controller must be removed and shipped to Club Car before it can ever be placed in “private speed mode”. **See Code A, Code B, and Code C on page 29-3. See also Password Tries (IQDM-P only) on page 22-5.**

Fault History

The *fault history* menu can be useful in determining the cause of a vehicle problem; however, the fault history alone should not be the factor that determines when a component is replaced. Some faults detected by the speed controller are not the result of a failed component, and are instead the result of vehicle operator error. If a fault appears in the *fault history* menu, the trained technician should attempt to determine when and where the fault has occurred. For example, if the *motor stall* fault is present in the fault history, the trained technician may be able to determine the location on the course where an operator has held the vehicle on a hill by using the accelerator pedal.

Clearing Fault History

After a repair has been made, the fault history should be cleared. This will enable the trained technician to properly troubleshoot the vehicle in the future, in the event that another problem occurs. It is recommended that the fault history be cleared in order to avoid the replacement of a component that caused a fault in the past, but has been replaced and is now functioning correctly. For example, if the MCOR device was disconnected and the speed controller detected a fault code associated with the throttle, the fault history should be cleared so that any future problem is not diagnosed incorrectly as a throttle problem. **See Clear Fault History on page 22-15.** All of the occurrence numbers located in the lower section of the monitor menu will be reset to zero each time the fault history is cleared except for the High Speed WalkAway occurrence numbers.

FUNCTIONS MENU

The *functions* menu is accessed by using the up or down arrow to scroll to *functions* and pressing the right arrow key to activate the menu.

GET SETTINGS FROM CONTROLLER

This function transfers all of the speed controller settings (except for “private speed mode”) from the vehicle speed controller to the handset. This enables the trained technician to “clone” a speed controller. Once the speed controller settings have been transferred to the handset, the technician can then connect the handset to another vehicle and transfer the stored settings into the speed controller.

Speed Controller Cloning – Transferring Settings from the Vehicle to the Handset

1. Locate a vehicle that has the desired speed controller settings.
2. Turn the key switch to the OFF position, place the Forward/Reverse handle in the NEUTRAL position, and lock the park brake.
3. Plug the handset into the vehicle.
 - 3.1. Connect one end of the cable to the jack located on the bottom of the handset.
 - 3.2. Connect the cable adaptor to the IQDM cable.
 - 3.3. Remove the dust cap from the IQDM jack.
 - 3.4. Align the keyed portion of the plug with the IQDM jack and connect the plug to the jack **(Figure 22-4, Page 22-12 or Figure 22-5, Page 22-12)**.
4. Scroll to the *functions* menu and select.
5. Select *settings*.
6. Select *get settings from controller*.
7. Press + on the change value button to confirm the operation.
8. The handset will display an “executing...” message for the next few seconds while the controller settings are being stored in the handset’s memory **(Figure 22-4, Page 22-12)**.
9. When the handset is finished recording the speed controller settings, a confirmation message is displayed **(Figure 22-5, Page 22-12)**.
10. With the controller settings stored in the memory of the handset, the handset can be used to transfer all of the desired speed controller settings to any IQ System vehicle or group of IQ System vehicles. **See Speed Controller Cloning – Transferring Settings from the Handset to the Vehicle on page 22-12.**

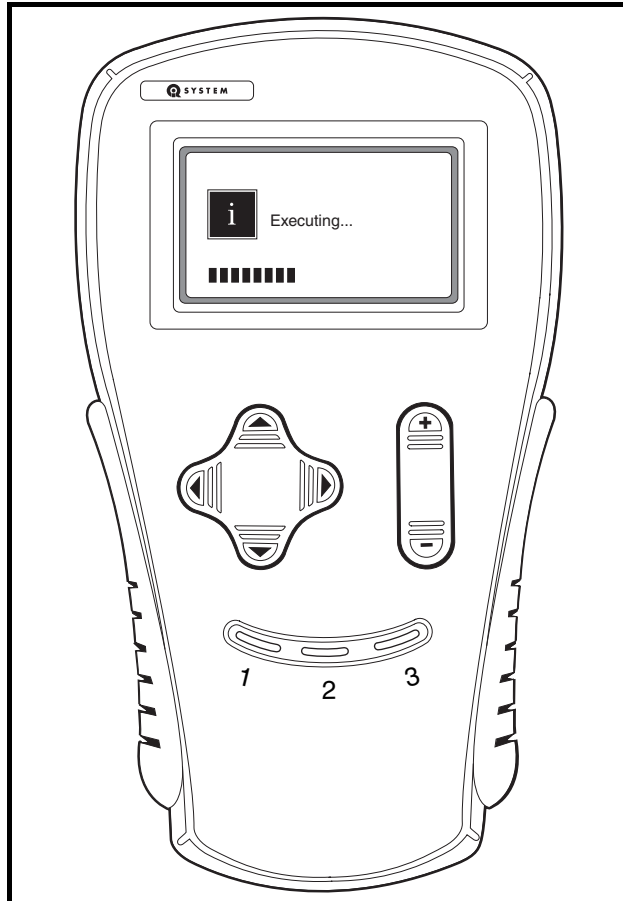

Figure 22-4 Handset Executing

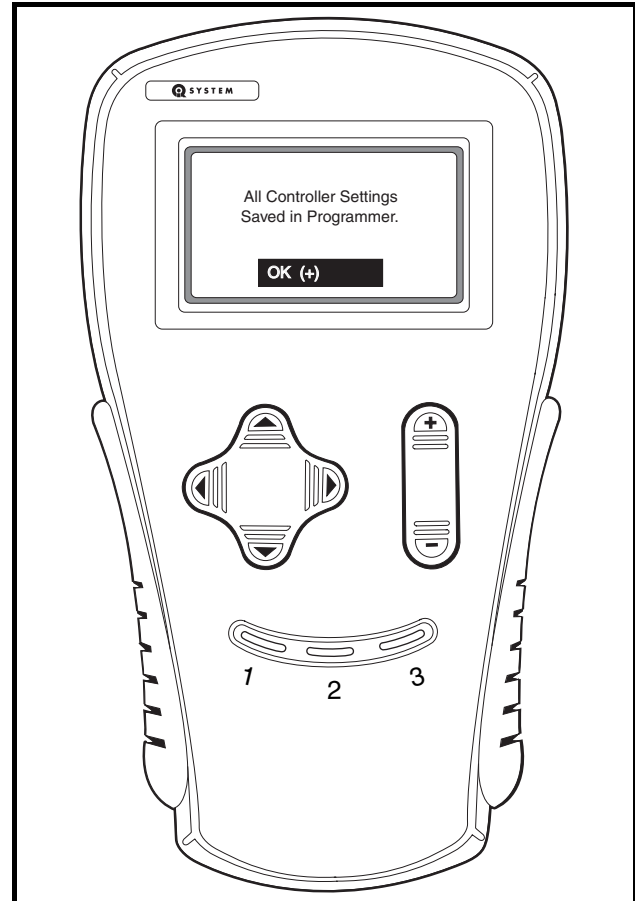

Figure 22-5 Confirmation Message

WRITE SETTINGS TO CONTROLLER

This function transfers all of the speed controller settings (except for “private speed mode”) from the handset to the vehicle speed controller. This enables the trained technician to “clone” a speed controller. Once the speed controller settings have been transferred to the handset, the technician can then connect the handset to another vehicle and transfer the stored settings into the speed controller.

Speed Controller Cloning – Transferring Settings from the Handset to the Vehicle

1. Perform this procedure with a handset that has the desired speed controller settings. **See Speed Controller Cloning – Transferring Settings from the Vehicle to the Handset on page 22-11.**
2. Locate a vehicle that does **not** have the desired speed controller settings.
3. Turn the key switch to the OFF position, place the Forward/Reverse handle in the NEUTRAL position, and lock the park brake.
4. Plug the handset into the vehicle.
 - 4.1. Connect one end of the cable to the jack located on the bottom of the handset.
 - 4.2. Connect the cable adaptor to the IQDM cable.
 - 4.3. Remove the dust cap from the IQDM jack.
 - 4.4. Align the keyed portion of the plug with the IQDM jack and connect the plug to the jack **(Figure 22-4, Page 22-12 or Figure 22-5, Page 22-12).**
5. Scroll to the *functions* menu and select.

6. Select *settings*.
7. Select *write settings to controller*.
8. Press + on the change value button to confirm the operation.
9. The handset will display an “executing...” message for the next few seconds while the controller settings are being stored in the handset’s memory (**Figure 22-4, Page 22-12**).
10. When the handset is finished transferring the speed controller settings, a confirmation message is displayed (**Figure 22-6, Page 22-13**).
11. Repeat this procedure for additional vehicles that need to be programmed with the same handset settings.

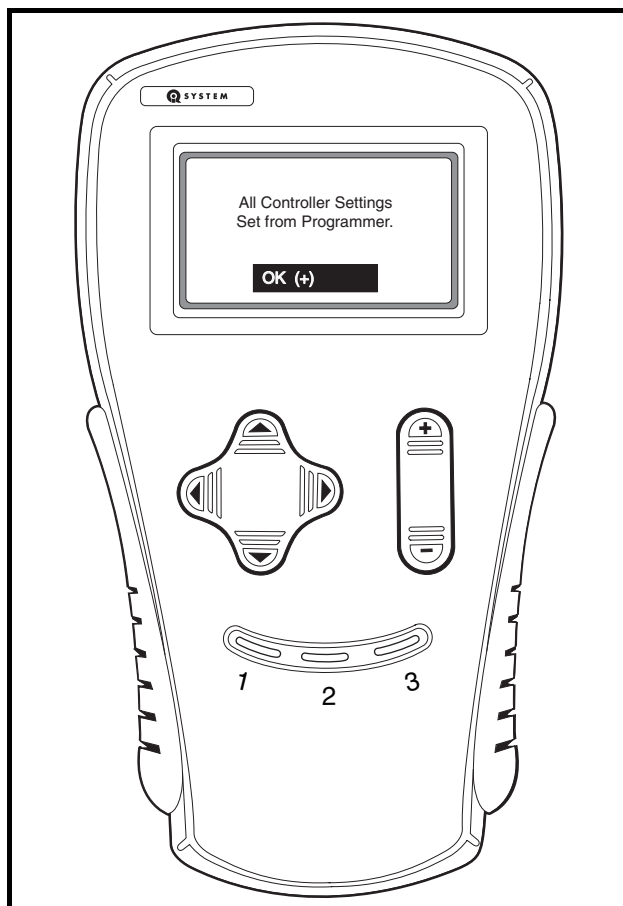

Figure 22-6 Confirmation Message

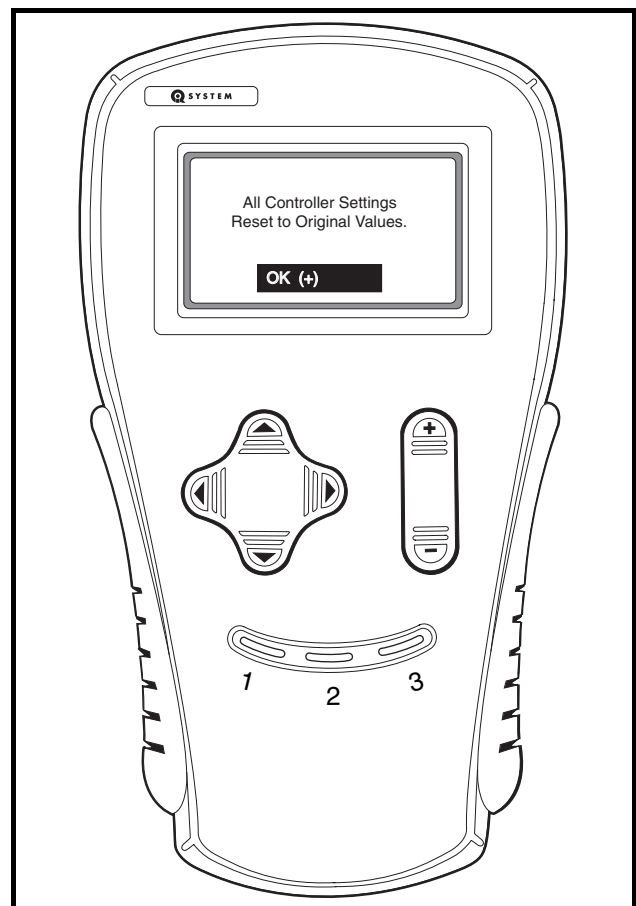

Figure 22-7 Confirmation Message

RESET ALL SETTINGS

In the event that a mistake was made and one or more changes should not have been made with the handset, the speed controller settings can be reverted to the original settings from the beginning of the session (when the handset was plugged into the vehicle). This function is similar to the “undo” command on a PC and will work correctly only when the handset has **not** been unplugged and power to the speed controller has **not** been interrupted.

Resetting All Settings

1. During an active session when the settings need to be returned to the original values (the values that were active at the beginning of the session), scroll to the *functions* menu and select.
2. Select *settings*.
3. Select *reset all settings*.
4. Press + on the change value button to confirm the operation.
5. The handset will display an “executing...” message for the next few seconds while the controller settings are being stored in the handset’s memory (**Figure 22-4, Page 22-12**).
6. When the handset is finished resetting the speed controller settings, a confirmation message is displayed (**Figure 22-7, Page 22-13**).

INFORMATION

The *information* menu is accessed by using the up or down arrow to scroll to *information* and pressing the right arrow key to activate the menu.

This menu selection displays information pertaining to the speed controller. The information provided from this menu selection includes:

Model Number

Displays the model number of the speed controller.

Serial Number

Displays the serial number of the speed controller.

MFG Date

Displays the date the speed controller was manufactured.

Software Version

Displays the speed controller software version.

PROGRAMMER SETUP

The *programmer setup* menu selection allows the user to set the LCD display contrast, records the fault history of the handset, and displays information pertaining to the handset.

PROGRAM

This menu allows the user to adjust the contrast on the display screen. After selecting the *LCD-Contrast* menu, use the change value buttons to adjust the contrast for the best readability.

FAULTS

This menu selection displays faults that have been detected within the handset. This *faults* menu does not pertain to any faults detected in the speed controller.

The following faults can be detected within the handset:

CODE NUMBER	TEXT DISPLAYED
9	Time out error detect, no response from controller
14	Communication error with controller
15	Error in handset
16	Handset does not support this function
17	Serial port overrun error
18	Security lockout on program menu

Fault History

This menu displays any faults that have been detected within the handset itself.

Clear Fault History

The *clear fault history* function will erase the history of faults that are stored in the handset.

INFORMATION

This menu selection displays information pertaining to the handset. The information provided in this menu selection includes model number, serial number, the date the handset was manufactured, the handset software version, etc.

IQDM AND IQDM-P HANDSET TROUBLESHOOTING

In the event that the handset does not function as described in this manual, the following troubleshooting guide should be studied and the referenced test procedures should be performed to troubleshoot the handset.

TROUBLESHOOTING GUIDE		
SYMPTOM	POSSIBLE CAUSES	CORRECTIVE ACTION
Handset display screen is blank	Handset cord and/or adaptor is disconnected	See Plugging the Handset into the Vehicle on page 1.
	Vehicle batteries – loose terminals or corrosion	See Section 24 – Batteries: Electric Vehicles.
	Vehicle batteries – improperly wired	See Section 24 – Batteries: Electric Vehicles.
	Vehicle batteries – batteries failed	See Section 24 – Batteries: Electric Vehicles.
	Vehicle batteries – batteries not fully charged	See Section 24 – Batteries: Electric Vehicles.
	Handset cord has failed	Test Procedure 1 – Handset Cord on page 22-17
	Handset cord adaptor has failed	Test Procedure 2 – Handset Cord Adaptor on page 22-18
	IQDM jack (on vehicle F&R switch) has failed	Test Procedure 3 – IQDM Jacks on page 22-18
	Contrast Setting is too light	See Program on page 22-14.
	Onboard computer is in power-down mode	Drive the vehicle for a short distance and reconnect the handset to the vehicle.
	Onboard computer malfunction	See Section 21 – Electrical System and Testing: Electric Vehicle.
	Loose vehicle wire harness connections	Test Procedure 3 – IQDM Jacks on page 22-18
	Speed controller malfunction	See Section 21 – Electrical System and Testing: Electric Vehicle.
Handset has failed	Replace handset	
Display screen shows jumbled or undecipherable characters	Speed controller malfunction	See Section 21 – Electrical System and Testing: Electric Vehicle.
	Handset malfunction	Disconnect the IQDM cord from the vehicle. Wait a few seconds and reconnect the handset to the vehicle
	Loose connection at IQDM jack	Test Procedure 3 – IQDM Jacks on page 22-18
	Intermittent handset cord failure	Test Procedure 1 – Handset Cord on page 22-17
	Intermittent handset cord adaptor failure	Test Procedure 2 – Handset Cord Adaptor on page 22-18
	Loose vehicle wire harness connections	Test Procedure 3 – IQDM Jacks on page 22-18
Troubleshooting Guide continued on next page...		

TROUBLESHOOTING GUIDE		
SYMPTOM	POSSIBLE CAUSES	CORRECTIVE ACTION
Handset is "locked-up" – buttons do not respond	Handset malfunction	Disconnect the IQDM cord from the vehicle. Wait a few seconds and reconnect the handset to the vehicle
	Vehicle batteries – loose terminals or corrosion	See Section 24 – Batteries: Electric Vehicles.
	Vehicle batteries – improperly wired	See Section 24 – Batteries: Electric Vehicles.
	Vehicle batteries – batteries failed	See Section 24 – Batteries: Electric Vehicles.
	Vehicle batteries – batteries not fully charged	See Section 24 – Batteries: Electric Vehicles.
	Speed controller malfunction	See Section 21 – Electrical System and Testing: Electric Vehicle.

TEST PROCEDURES

The following test procedures enable the technician to test the IQDM and IQDM-P handsets and the components of the IQ System vehicle that are related to the proper operation of the handset.

WARNING

- If wires are removed or replaced, make sure wiring and wire harness are properly routed and secured. Failure to properly route and secure wiring could result in vehicle malfunction, property damage, personal injury, or death.

INDEX OF TEST PROCEDURES

1. Handset Cord
2. Handset Cord Adaptor
3. IQDM Jacks

TEST PROCEDURE 1 – HANDSET CORD

See General Warning on page 1-1.

1. Using a multimeter set for 200 ohms, place the red (+) probe into one of the terminals on the end of the cord with the square plug.
2. Place the black (–) probe on each of the pins, one at a time, on the plug on the other end of the cord.
3. The multimeter should indicate continuity on only one pin. If any other reading is obtained, the cord must be replaced.
4. Repeat the procedure three more times, each time with the red (+) probe inserted into a different terminal on the end of the cord with the square plug.

TEST PROCEDURE 2 – HANDSET CORD ADAPTOR

See General Warning on page 1-1.

The procedure for testing the handset cord adaptor is similar to the cord test.

1. Using a multimeter set for 200 ohms, place the red (+) probe into one of the terminals on the end of the adaptor with the square plug.
2. Place the black (–) probe on each of the pins, one at a time, on the other plug of the adaptor.
3. The multimeter should indicate continuity on only one pin. If any other reading is obtained, the adaptor must be replaced.
4. Repeat the procedure three more times, each time with the red (+) probe inserted into a different terminal on the end of the adaptor with the square plug.

TEST PROCEDURE 3 – IQDM JACKS

See General Warning on page 1-1.

Test Procedure 3A – IQDM Jack (Located on F&R Switch Housing)

1. Turn the key switch to the OFF position, place the Forward/Reverse control in the NEUTRAL position, and lock the park brake.
2. Place the Tow/Run switch in the TOW position, disconnect the batteries, negative (–) cable first, and wait 90 seconds for the speed controller capacitors to discharge. **See General Warning on page 1-1.**
3. Check the IQDM jack (1) at the Forward/Reverse switch housing.
 - 3.1. Remove the three self-tapping screws that hold the F&R rocker switch housing (2) to the body (Figure 22-8, Page 22-18).

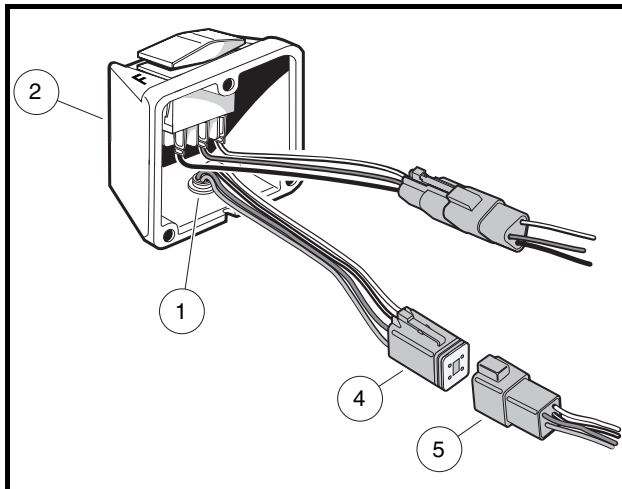

Figure 22-8 IQDM Jack On F&R Switch Housing

- 3.2. Disconnect the four-pin connectors (4 and 5) and visually inspect the contacts for damage and corrosion. Inspect the IQDM jack (1), located on the bottom of the switch housing (2). Repair and replace parts as necessary.
- 3.3. If no problem is found, connect the four-pin connectors and install the F&R switch housing.
- 3.4. Install the three self-tapping screws that hold the F&R rocker switch housing (2) to the body. Tighten IQDM Jack.

Test Procedure 3B – IQDM Jack (Located Under Instrument Panel) (Turf 1/Carryall 1)

1. Turn the key switch to the OFF position, place the Forward/Reverse control in the NEUTRAL position, and lock the park brake.
2. Place the Tow/Run switch in the TOW position, disconnect the batteries, negative (–) cable first, and wait 90 seconds for the speed controller capacitors to discharge. **See General Warning on page 1-1.**
3. Check the IQDM jack mounted under the instrument panel.
 - 3.1. Remove the center dash panel (**Figure 22-9, Page 22-19**).
 - 3.1.1. Remove the plastic cap (1) covering the mounting screw (2) on each side of the center dash panel (3).
 - 3.1.2. Loosen, but do not remove, the screw (2) on each side of the center dash panel (3).
 - 3.1.3. Insert screwdriver at the top center of the dash between dash and cowl brace. Gently pry center dash out slightly from under edge of cowl brace.
 - 3.1.4. Pull center dash out from the frame carefully and expose the wiring of the electrical components mounted on the dash panel. Do not allow wires to touch. **See following NOTE.**

NOTE: Take care to prevent key switch terminals and wires from touching the metal frame around the dash.

- 3.2. Disconnect the IQDM jack four-pin connectors (4 and 5) and visually inspect the contacts for damage and corrosion. Inspect the IQDM jack mounted to the bottom of the dash panel. Repair and replace parts as necessary.
- 3.3. If no problem is found, connect the multi-pin connectors and install the center dash panel.
- 3.4. Install the three self-tapping screws that hold the F&R rocker switch case (2) to the body. Tighten to 20 in-lb (2.2 N·m).
- 3.5. Align the keyed portion of the plug with the IQDM jack and connect the plug to the jack. If the handset fails to function, **See IQDM and IQDM-P Handset Troubleshooting on page 22-16.**

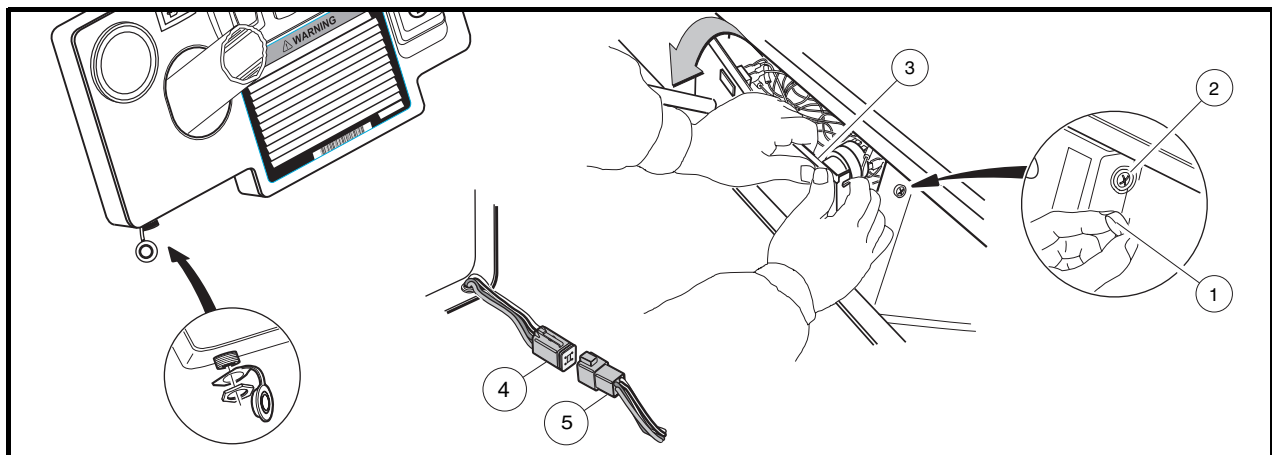

Figure 22-9 Testing IQDM Jack Located Under Instrument Panel

Test Procedure 3C – IQDM Jack (Speed Controller)

1. Turn the key switch to the OFF position, place the Forward/Reverse control in the NEUTRAL position, and lock the park brake.
2. Place the Tow/Run switch in the TOW position, disconnect the batteries, negative (–) cable first, and wait 90 seconds for the speed controller capacitors to discharge. **See General Warning on page 1-1.**

3. Check the IQDM jack on the speed controller.
 - 3.1. Remove the two screws securing the rear body access panel and remove the access panel.
 - 3.2. Remove the two screws (5) securing the controller cover (1) to the component mounting plate (**Figure 22-10, Page 22-20**).
 - 3.3. Disconnect the square four-pin connector (3) from the speed controller.
 - 3.4. Connect the handset cord to the handset.
 - 3.5. Connect the other end of the handset cord (without the adapter) (4) to the four-pin connector of the speed controller (2) (**Figure 22-10, Page 22-20**).
 - 3.6. Connect the vehicle batteries, positive (+) cable first.
 - 3.7. If the handset functions when connected directly to the speed controller, the adapter plug or vehicle wire harness should be thoroughly tested. **See Test Procedure 2 – Handset Cord Adaptor on page 22-18. See also Section 21 – Electrical System and Testing: Electric Vehicle**

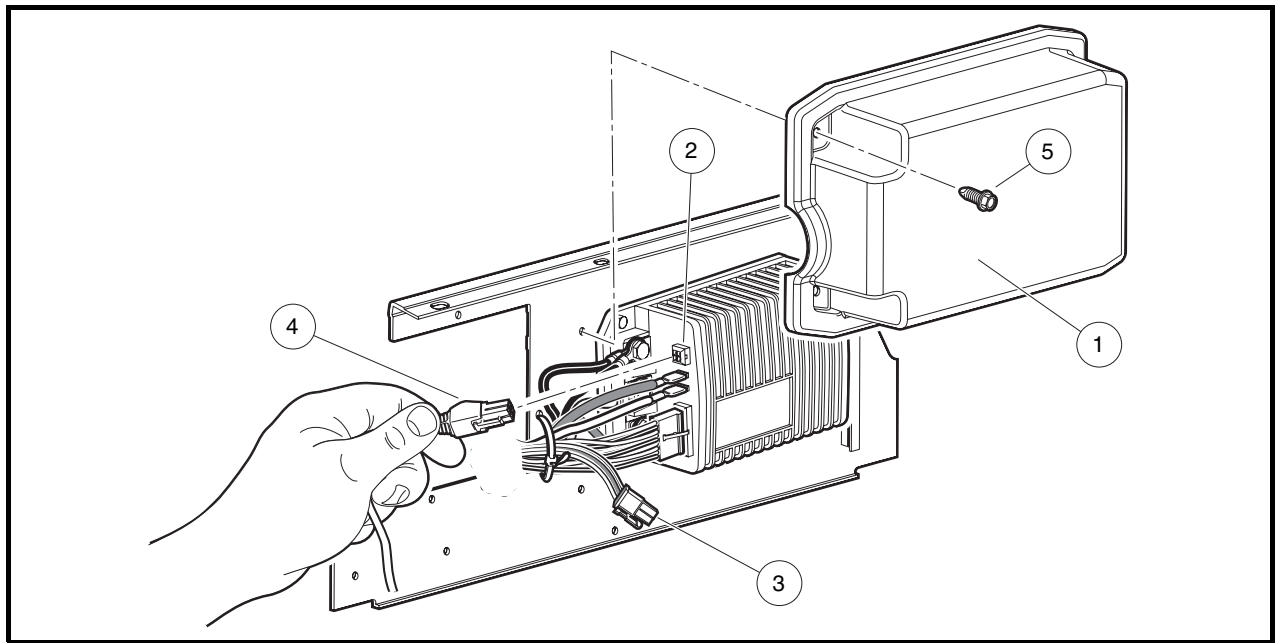

Figure 22-10 IQ System Component Mounting Plate

SECTION 23 – ELECTRICAL COMPONENTS: ELECTRIC VEHICLE

⚠ DANGER

- See General Warning on page 1-1.

⚠ WARNING

- See General Warning on page 1-1.

KEY SWITCH – 800 AND 810

See General Warning on page 1-1.

Testing the Key Switch

See Test Procedure 8, Section 21, Page 21-16.

Key Switch Removal

1. Turn the key switch OFF and remove the key. Place the Forward/Reverse handle in the NEUTRAL position. Chock the wheels.
2. Disconnect the battery cables as instructed. **See WARNING “To avoid unintentionally starting...” in General Warning on page 1-2.**
3. Remove the instrument panel.
 - 3.1. Loosen seven Tuflok screws, but do not remove screws completely, as shown in Detail A (**Figure 23-1, Page 23-2**).
 - 3.2. Remove Tuflok screws from instrument panel as shown in Detail B.
 - 3.3. Pull forward on top of instrument panel to access back side of key switch.
 - 3.4. Disconnect the wire connectors from the key switch.
4. Remove the key switch.
 - 4.1. Remove the key switch nut (1) (**Figure 23-2, Page 23-2**).
 - 4.2. Remove key switch (2) from back side of instrument panel.

Key Switch Installation

1. Install the key switch in the instrument panel in reverse order of removal. Tighten the key switch nut firmly. Reconnect the wire connector to the key switch.
2. Install the instrument panel in reverse order of removal.
3. Place the Tow/Run switch in the TOW position and connect the battery cables, positive (+) cable first. Tighten battery terminals to 110 in-lb (12.4 N·m) and coat terminals with Battery Terminal Protector Spray (CCI P/N 1014305) to minimize corrosion.

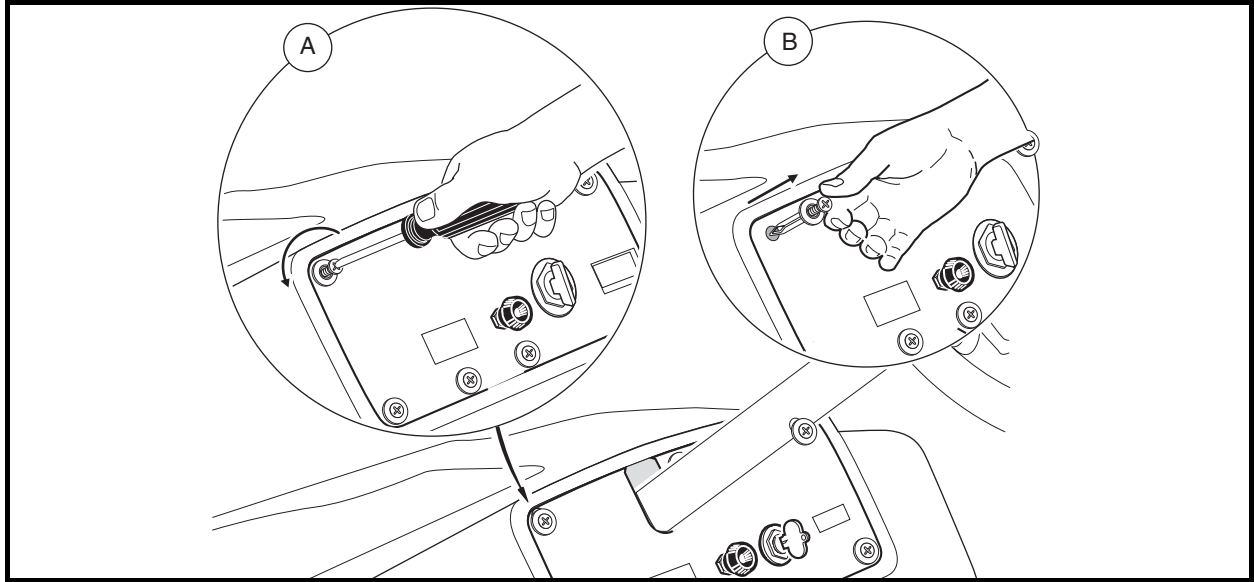

Figure 23-1 Instrument Panel Removal – 800 and 810

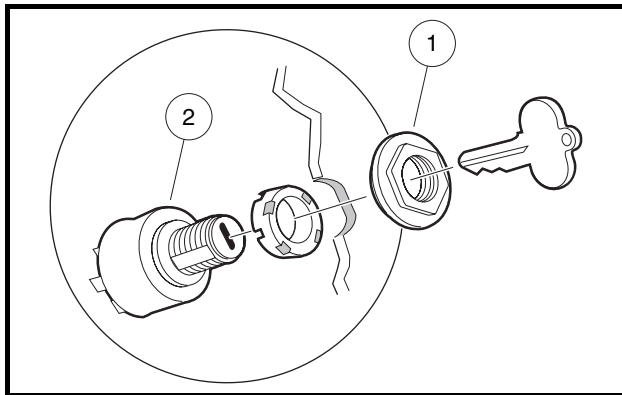

Figure 23-2 Key Switch Removal – 800 and 810

KEY SWITCH – 850

See General Warning on page 1-1.

Testing the Key Switch

See Test Procedure 4 – Key Switch (Starter Circuit) on page 12-13.

Key Switch Removal

1. Place the Tow/Run switch in the TOW position.
2. Disconnect the battery cables as instructed. See **WARNING “To avoid unintentionally starting...”** in **General Warning on page 1-2.**
3. Remove the center dash panel (**Figure 23-3, Page 23-3**).
 - 3.1. Remove the plastic cap (1) covering the mounting screw (2) on each side of the center dash panel (3) (**Figure 23-3, Page 23-3**).
 - 3.2. Loosen, but do not remove, the screw (2) on each side of the center dash panel (3).

- 3.3. Insert screwdriver at the top center of the dash between dash and cowl brace. Gently pry center dash out slightly from under edge of cowl brace.
- 3.4. Pull center dash out from the frame and disconnect the wires from the electrical components mounted on the dash panel. Do not allow wires to touch. **See following NOTE.**

NOTE: Take care to prevent key switch terminals and wires from touching the metal frame around the dash.

4. Slide center dash panel up steering column by snapping top out and then rotating the panel out and up.
5. Disconnect the wires from the key switch. Do not allow wires to touch.
6. From the back of the dash panel, push down on the retaining tabs surrounding the key switch (4) and remove the key switch cap (8). Hold the key switch and remove the switch retaining nut (6) from the outside of the dash panel (**Figure 23-4, Page 23-4**).

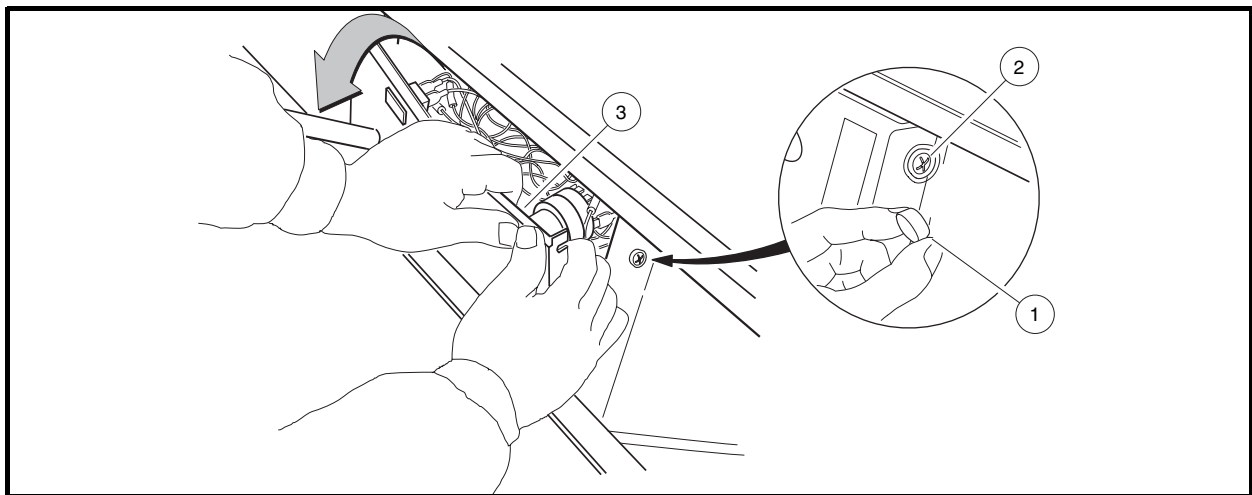

Figure 23-3 Dash Removal – 850

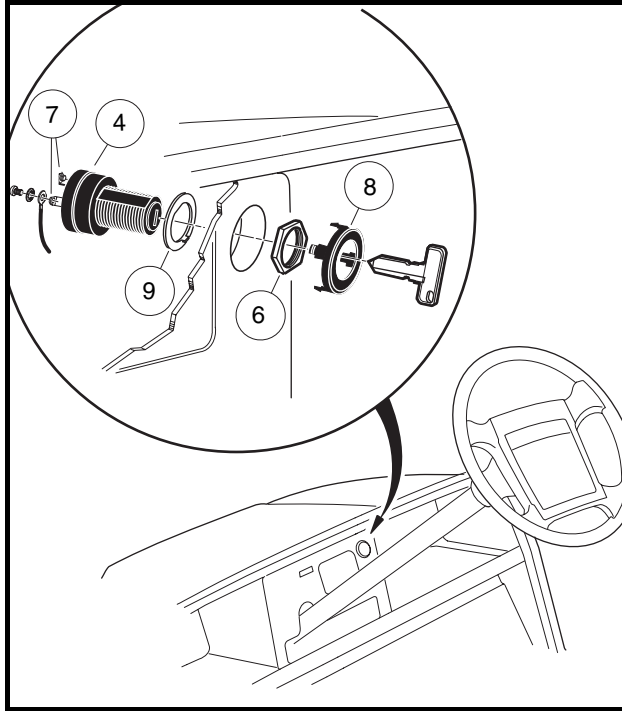

Figure 23-4 Key Switch – 850

Key Switch Installation

1. Position the key switch and flat washer (9) in the center dash, then install and tighten the switch retaining nut (6) to 40 in-lb (4.5 N·m). Install key switch cap (8) in center dash (**Figure 23-4, Page 23-4**).
2. Refer to the wiring diagram to connect the wires to the key switch terminals and tighten the terminal screws to 7 in-lb (0.8 N·m). **See Wiring Diagram on page 12-6.** Coat the terminals with Battery Terminal Protector Spray (CCI P/N 1014305).
3. Install center dash by reversing removal procedure. Make sure key switch terminals (7) do not touch frame and that the center dash panel is properly seated and snapped into place (**Figure 23-4, Page 23-4**).
4. Place the Tow/Run switch in the TOW position and connect the battery cables, positive (+) cable first. Tighten battery terminals to 110 in-lb (12.4 N·m) and coat terminals with Battery Terminal Protector Spray (CCI P/N 1014305) to minimize corrosion.

FORWARD/REVERSE SWITCH – 800 AND 810

See General Warning on page 1-1.

Testing the Forward/Reverse Rocker Switch

See Test Procedure 15, Section 21, Page 21-30.

Forward/Reverse Switch Removal

1. Disconnect the battery cables as instructed. **See WARNING “To avoid unintentionally starting...” in General Warning on page 1-2.**

2. Remove three screws (3) that hold Forward/Reverse rocker switch housing (2) to body (**Figure 23-5, Page 23-5**).
3. Remove the 18-gauge brown, orange, and blue wires from the Forward/Reverse rocker switch.
4. Press the locking tabs (11) on each end of switch and push switch out of housing.

Forward/Reverse Switch Installation

1. Press the locking tabs (11) on each end of the rocker switch and push switch into housing (2) (**Figure 23-5, Page 23-5**).
2. Connect the 18-gauge brown, orange, and blue wires to the rocker switch exactly as shown in the wiring diagram (**Figure 21-1, Page 21-2**).
3. Install three screws (3) that hold Forward/Reverse rocker switch housing (2) to body. Tighten to 20 in-lb (2.3 N·m) (**Figure 23-5, Page 23-5**).
4. Place the Tow/Run switch in the TOW position and connect the battery cables, positive (+) cable first. Tighten battery terminals to 110 in-lb (12.4 N·m) and coat terminals with Battery Terminal Protector Spray (CCI P/N 1014305) to minimize corrosion.
5. Place the Tow/Run switch in the RUN position.
6. Inspect the vehicle for proper operation:
 - Make sure that the vehicle operates in the forward direction when the Forward/Reverse switch is in the FORWARD position.
 - Make sure that the vehicle operates in the reverse direction when the Forward/Reverse switch is in the REVERSE position. The reverse buzzer will sound as a warning when the Forward/Reverse switch is in REVERSE.
 - Make sure that the vehicle does not operate when the Forward/Reverse switch is in the NEUTRAL position.

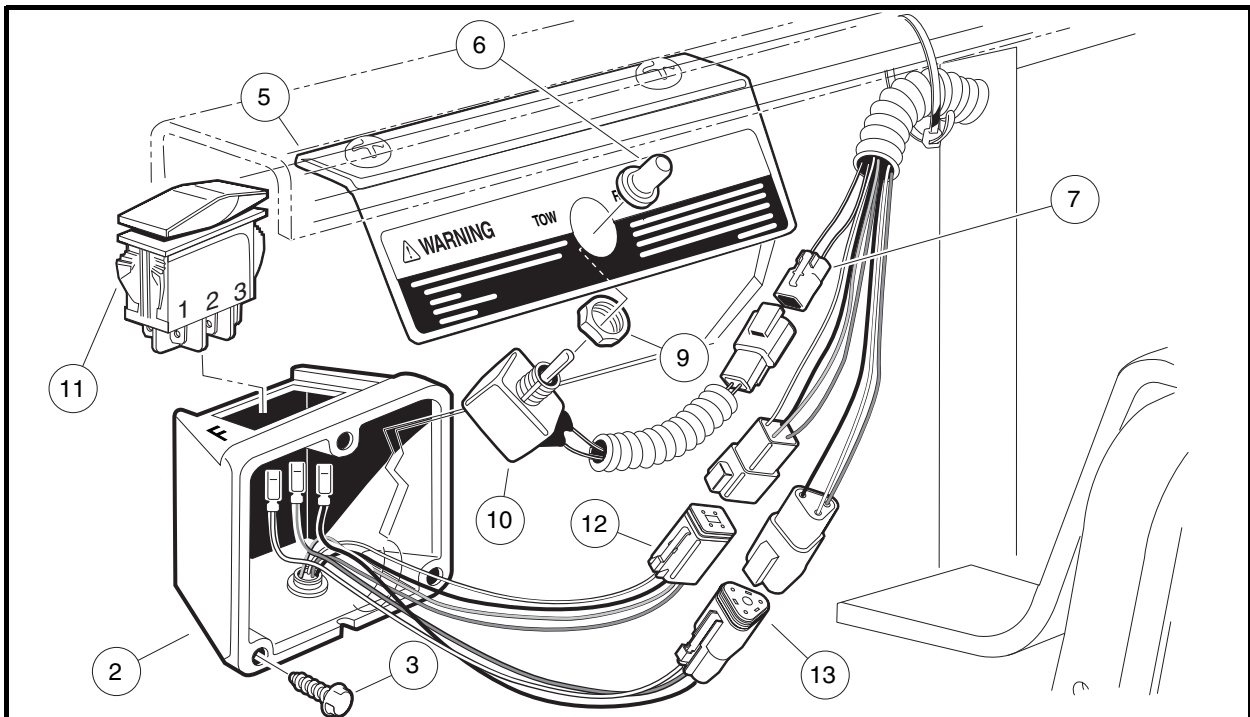

Figure 23-5 Tow/Run Switch and Forward/Reverse Rocker Switch – 800 and 810

FORWARD/REVERSE ROCKER SWITCH – 850

See General Warning on page 1-1.

Testing the Forward/Reverse Rocker Switch

See Test Procedure 15 – Forward/Reverse Rocker Switch on page 21-30.

Forward/Reverse Rocker Switch Removal

1. Place the Tow/Run switch in the TOW position.
2. Disconnect the battery cables as instructed. See **WARNING “To avoid unintentionally starting...”** in **General Warning on page 1-2.**
3. Remove the center dash panel (**Figure 23-3, Page 23-3**).
4. Remove the 18-gauge brown, orange, and blue wires from the rocker switch.
5. Press the locking tabs on each end of switch (11) and push switch out of dash panel (**Figure 23-6, Page 23-7**).

Forward/Reverse Rocker Switch Installation

1. Press the locking tabs on each end of the rocker switch (11) and push switch into dash panel (**Figure 23-6, Page 23-7**).
2. Connect the 18-gauge brown, orange, and blue wires to the rocker switch exactly as shown in the wiring diagram. See **Wiring Diagram on page 12-6.**
3. Install center dash by reversing removal procedure. Make sure key switch terminals do not touch frame and that the center dash panel is properly seated and snapped into place.
4. Connect the battery cables, positive (+) cable first. Tighten battery terminals to 110 in-lb (12.4 N-m) and coat terminals with Battery Terminal Protector Spray (CCI P/N 1014305) to minimize corrosion.
5. Place the Tow/Run switch in the RUN position.
6. Inspect the vehicle for proper operation:
 - Make sure that the vehicle operates in the forward direction when the Forward/Reverse switch is in the FORWARD position.
 - Make sure that the vehicle operates in the reverse direction when the Forward/Reverse switch is in the REVERSE position. The reverse buzzer will sound as a warning when the Forward/Reverse switch is in REVERSE.
 - Make sure that the vehicle does not operate when the Forward/Reverse switch is in the NEUTRAL position.

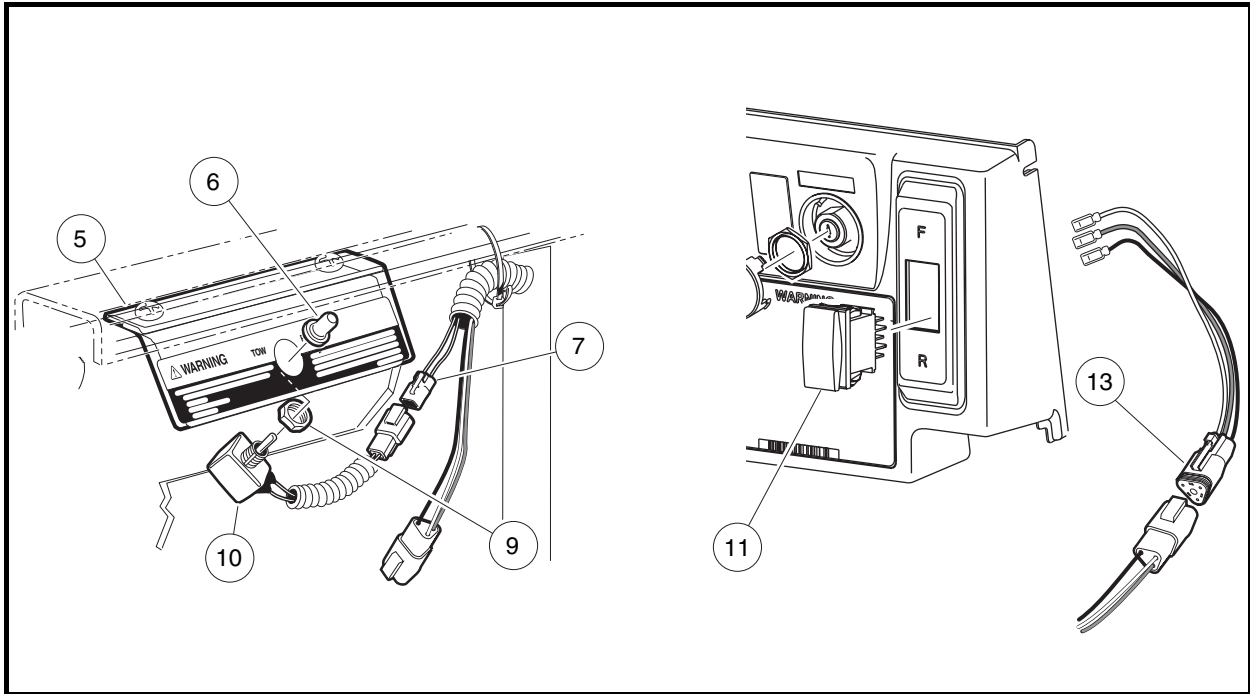

Figure 23-6 Tow/Run Switch and Forward/Reverse Rocker Switch – 850

TOW/RUN SWITCH

See General Warning on page 1-1.

Testing the Tow/Run Switch

See Test Procedure 6, Section 21, Page 21-15.

Tow/Run Switch Removal

1. Disconnect the battery cables as instructed. See **WARNING “To avoid unintentionally starting...”** in General Warning on page 1-2.
2. Remove Tow/Run switch boot/hex nut (6) (Figure 23-5, Page 23-5 and Figure 23-6, Page 23-7).
3. Remove Tow/Run switch (10) and nut (9) from bracket (5).
4. Disconnect the two-pin connector (7) and remove switch.

Tow/Run Switch Installation

1. Installation is reverse of removal. Make sure groove on switch is aligned with tang on bracket. Tighten Tow/Run switch boot/hex nut (6) to 16 in-lb (1.8 N-m) (Figure 23-5, Page 23-5 and Figure 23-6, Page 23-7).
2. Place the Tow/Run switch in the TOW position and connect the battery cables, positive (+) cable first. Tighten battery terminals to 110 in-lb (12.4 N-m) and coat terminals with Battery Terminal Protector Spray (CCI P/N 1014305) to minimize corrosion.

MOTOR CONTROLLER OUTPUT REGULATOR (MCOR)

See General Warning on page 1-1.

Testing the MCOR

See Section 21, Test Procedure 4, Page 21-10 and Test Procedure 8, Page 21-16.

MCOR Removal

1. Disconnect the battery cables as instructed. See **WARNING “To avoid unintentionally starting...”** in **General Warning on page 1-2.**
2. Place chocks at rear wheels and lift the front of the vehicle with a chain hoist or floor jack. Place jack stands under the round tube crossmember of the frame to support vehicle. See **WARNING “Lift only one end...”** in **General Warning on page 1-1.**
3. Disconnect the two-pin and three-pin connectors (1) from the MCOR (2) (**Figure 23-7, Page 23-8.**)
4. Remove the hex-head screws (3) connecting the MCOR to the frame I-beam.
5. Remove the MCOR from vehicle.
6. Push the drive bar (4) into the hole in the I-beam to disengage it from the accelerator pivot rod (5).

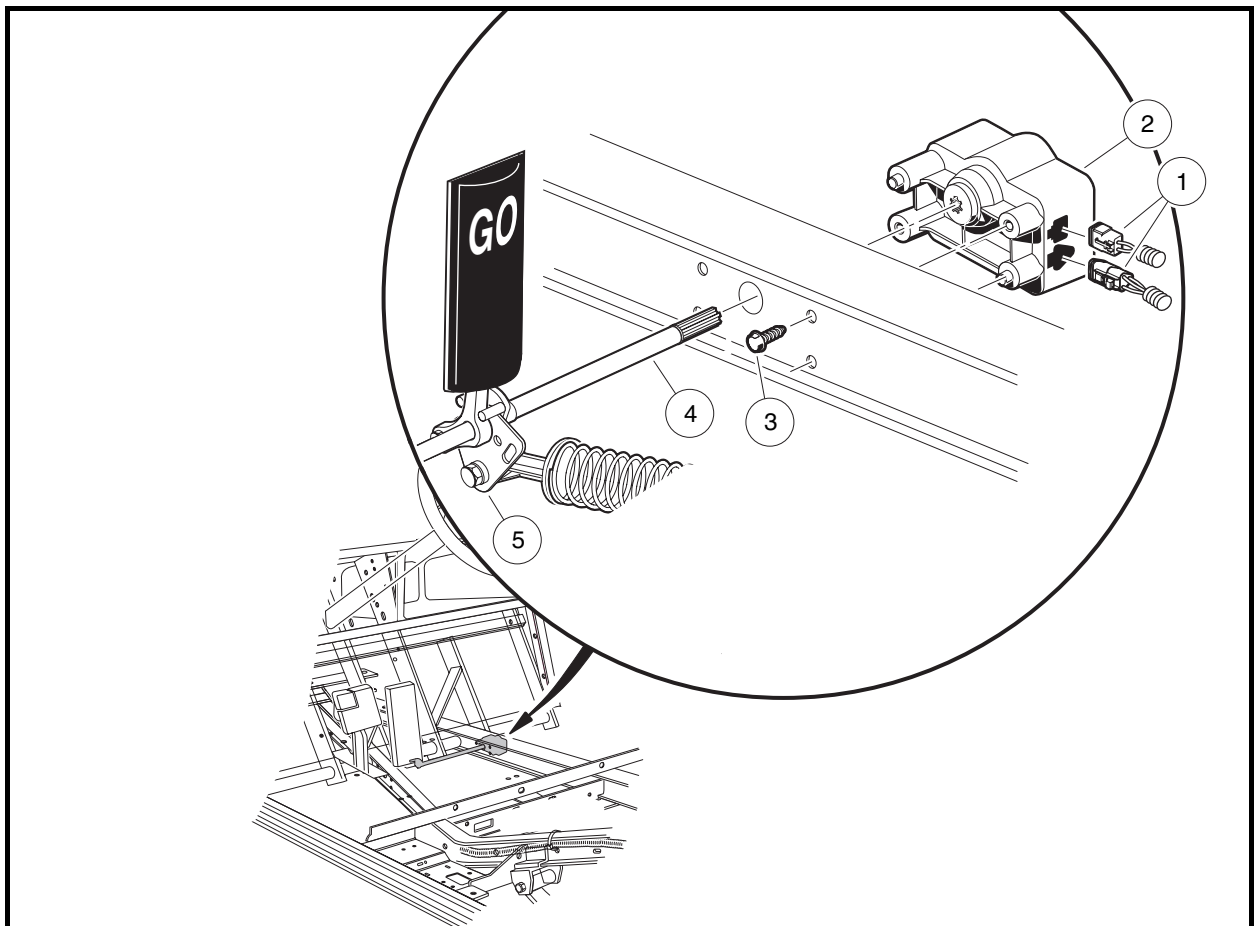

Figure 23-7 Motor Controller Output Regulator (MCOR) Mounting

MCOR Installation

1. Insert the splined end of the drive bar (4) through the hole in the passenger-side frame I-beam as shown (**Figure 23-7, Page 23-8**).
2. Position the opposite end of the drive bar so that the accelerator pedal sits between the two pins.
3. Place the MCOR (2) onto the splined end of the drive bar (**Figure 23-7, Page 23-8**). **See following NOTE.**

NOTE: The MCOR is keyed to ensure correct positioning on the drive bar.

4. Insert the alignment pins on the MCOR into the holes in the I-beam as shown.
5. Secure the MCOR to the frame I-beam with two hex-head screws (3). Tighten screws to 23 in-lb (2.6 N·m).
6. Connect the two-pin and three-pin connectors (1) from the wire harness to the MCOR.
7. Place the Tow/Run switch in the TOW position and connect the battery cables, positive (+) cable first. Tighten battery terminals to 110 in-lb (12.4 N·m) and coat terminals with Battery Terminal Protector Spray (CCI P/N 1014305) to minimize corrosion.

REVERSE BUZZER

See General Warning on page 1-1.

Testing the Reverse Buzzer

See Test Procedure 16, Section 21, Page 21-31.

Reverse Buzzer Removal

1. Disconnect the battery cables as instructed. **See WARNING “To avoid unintentionally starting...” in General Warning on page 1-2.**
2. Remove instrument panel. **See Key Switch Removal on page 23-1.**
3. Disconnect the 18-gauge red and orange/white wires from reverse buzzer.
4. Remove the two screws from the reverse buzzer. Remove the reverse buzzer from the instrument panel.

Reverse Buzzer Installation

1. Install the reverse buzzer in the reverse order of removal. Tighten screws to 4 in-lb (0.45 N·m).
2. Place the Tow/Run switch in the TOW position and connect the battery cables, positive (+) cable first. Tighten battery terminals to 110 in-lb (12.4 N·m) and coat terminals with Battery Terminal Protector Spray (CCI P/N 1014305) to minimize corrosion.

SOLENOID

See General Warning on page 1-1.

The solenoid is located on the driver side of the electrical component mounting plate.

Testing the Solenoid

See Section 21, Test Procedure 3, Page 21-12 and Test Procedure 14, Page 21-30.

Solenoid Removal

1. Disconnect the battery cables as instructed. See **WARNING “To avoid unintentionally starting...”** in **General Warning on page 1-2.**
2. Remove the rear body access panel.
3. Disconnect all wires from the solenoid.
4. Screw-mounted solenoid (**Figure 23-8, Page 23-10**).
 - 4.1. Loosen both solenoid mounting screws (12).
 - 4.2. Lift the solenoid (3) up and off of the component mounting plate.
5. Slot-mounted solenoid (**Figure 23-9, Page 23-10**).
 - 5.1. Slide solenoid up to disengage the mounting tabs and remove from component mounting plate..

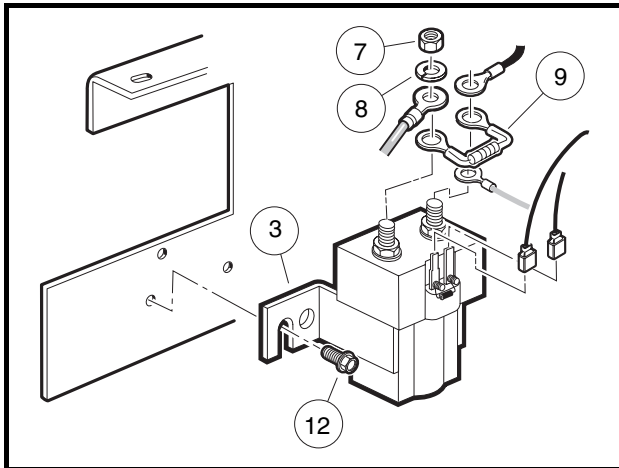

Figure 23-8 Screw-Mounted Solenoid

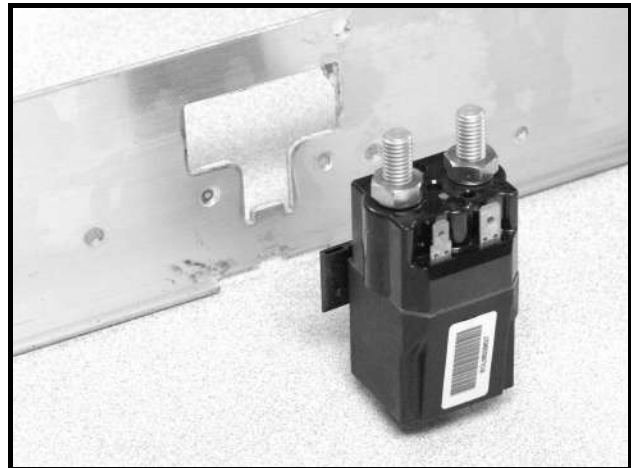

Figure 23-9 Slot-Mounted Solenoid

Solenoid Installation

1. Mount solenoid onto component mounting plate with screws (12) (**Figure 23-8, Page 23-10**) or by engaging slot (**Figure 23-9, Page 23-10**).
2. Tighten screws (12) to 60 in-lb (6.8 N·m).
3. Using the wiring diagram, install the wires, resistor (9), washers (8), and nuts (7) onto the large mounting posts. Tighten nuts to 77 in-lb (8.7 N·m). See **Wiring Diagram on page 21-2.**
4. Install the blue/white and light blue wires onto the small terminals of the solenoid (**Figure 23-8, Page 23-10**).
5. Install rear body access panel.

- Place the Tow/Run switch in the TOW position and connect the battery cables, positive (+) cable first. Tighten battery terminals to 110 in-lb (12.4 N-m) and coat terminals with Battery Terminal Protector Spray (CCI P/N 1014305) to minimize corrosion.

ONBOARD COMPUTER (OBC)

See **General Warning** on page 1-1.

Testing the Onboard Computer

See Section 21, Test Procedure 2, Page 21-11, Test Procedure 10, Page 21-28, and Test Procedure 11, Page 21-28.

Onboard Computer Removal

- Disconnect the battery cables as instructed. See **WARNING “To avoid unintentionally starting...”** in **General Warning** on page 1-2.
- Remove rear body access panel and unplug the six-pin connector (16) at the OBC (**Figure 23-10**, **Page 23-11**) or (**Figure 23-11**, **Page 23-11**).

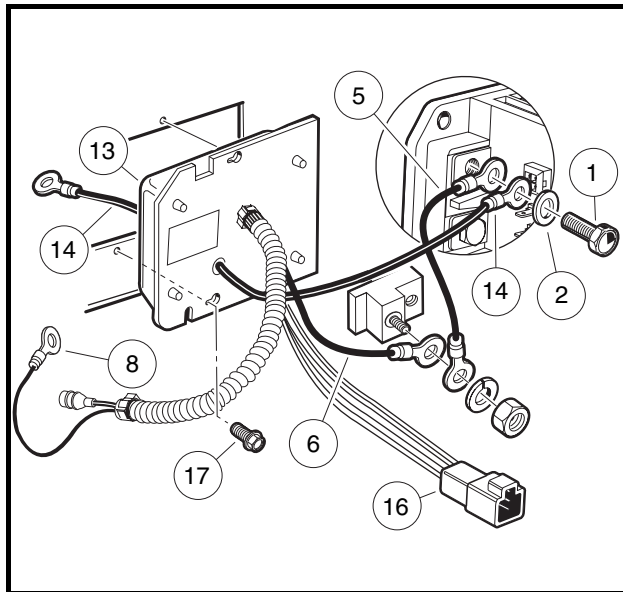

Figure 23-10 Early Onboard Computer

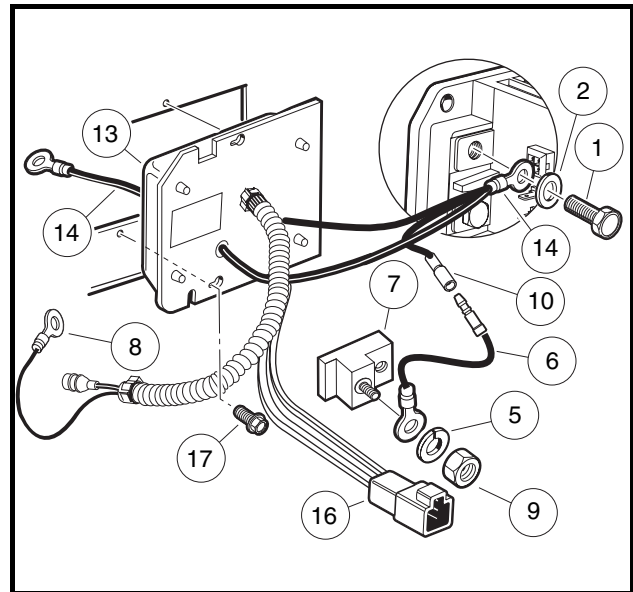

Figure 23-11 Later Onboard Computer

- Remove the two screws (5) from the speed controller cover (1) and remove the cover (**Figure 23-12**, **Page 23-13**).
- Remove the wire tie (3) securing the speed controller wires to the mounting plate.
- Remove black 6-gauge wire (14) from the speed controller B- terminal (**Figure 23-10**, **Page 23-11**) or (**Figure 23-11**, **Page 23-11**).
- Early OBC Only:** Remove the black 10-gauge wire (5) from the speed controller B- terminal and black 10-gauge wire (6) from the accessory mounting terminal (**Figure 23-10**, **Page 23-11**).
- Disconnect the gray wire fuse holder at the charger receptacle.
- Disconnect the black 10-gauge wire (8) at the charger receptacle.

9. Cut the wire tie that secures the OBC wire harness to the I-beam.
10. Loosen, but do not remove, the two self-tapping screws (17) holding OBC to component mounting plate.
11. Slide OBC towards outside of vehicle and align heads of self-tapping screws (17) with the two holes in the OBC face plate. Pull OBC towards rear of vehicle and remove from component mounting plate.

Onboard Computer Installation

1. Disconnect the battery cables as instructed. **See WARNING “To avoid unintentionally starting...” in General Warning on page 1-2.**
2. Remove the rear body access panel.
3. Install the OBC onto the component mounting plate by aligning the two holes on the OBC face plate with two holes on component mounting plate. Slide OBC towards inside of vehicle and align heads of self-tapping screws (17) with smaller part of two holes in OBC face plate (**Figure 23-10, Page 23-11**) or (**Figure 23-11, Page 23-11**). Tighten screws to 60 in-lb (6.7 N·m). **See following NOTE.**

NOTE: *The aluminum plate on the OBC should face toward the rear of the vehicle. The white potting material side of the OBC should face toward the front of the vehicle.*

4. Secure the OBC wire harness (consisting of the black 10-gauge wire (8) and the gray wire fuse holder) to the I-beam with wire ties (**Figure 23-10, Page 23-11**) or (**Figure 23-11, Page 23-11**).
5. Connect the black 10-gauge wire (8) to the charger receptacle (**Figure 23-10, Page 23-11**) or (**Figure 23-11, Page 23-11**). Tighten to 23 in-lb (2.6 N·m).
6. Connect the gray wire fuse holder to the charger receptacle.
7. **Early OBC Only:** Connect the black 10-gauge wire (6) and the black 10-gauge wire (5) to the accessory mounting terminal. Install the nut on the accessory terminal and tighten to 9 ft-lb (12.2 N·m) (**Figure 23-10, Page 23-11**).
8. Connect the black 6-gauge wire (14) (and black 10-gauge wire (5), if early OBC) to the speed controller B– terminal with the washer (2) and bolt (1) and tighten to 9 ft-lb (12.2 N·m) (**Figure 23-10, Page 23-11**) or (**Figure 23-11, Page 23-11**).
9. Plug the six-pin connector (16) from the OBC into the vehicle wire harness.
10. Install a wire tie (3) to tightly secure the speed controller wires to the component mounting plate (**Figure 23-12, Page 23-13**).
11. Place the edge of the speed controller cover (1) into the slot (2). Press the controller cover onto the component mounting plate over the speed controller and install the two screws (5) (**Figure 23-12, Page 23-13**). Tighten the screws (5) to 60 in-lb (6.8 N·m). **See following NOTE.**

NOTE: *Make sure that the speed controller cover gasket forms a tight seal between the cover and the component mounting plate.*

12. Install rear body access panel.
13. Place the Tow/Run switch in the TOW position and connect the battery cables, positive (+) cable first. Tighten battery terminals to 110 in-lb (12.4 N·m) and coat terminals with Battery Terminal Protector Spray (CCI P/N 1014305) to minimize corrosion.

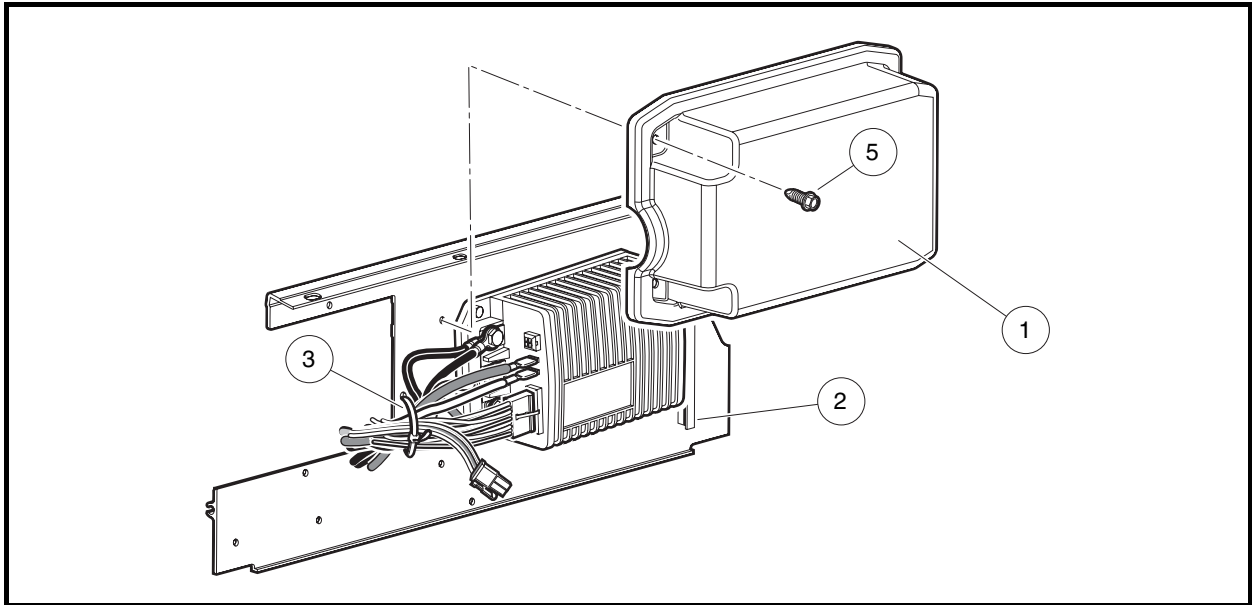

Figure 23-12 Speed Controller Cover

SOLID STATE SPEED CONTROLLER

See General Warning on page 1-1.

Testing the Solid State Speed Controller

See Test Procedure 5, Section 21, Page 21-14.

Speed Controller Removal

1. Disconnect the battery cables as instructed. **See WARNING “To avoid unintentionally starting...” in General Warning on page 1-2.**
2. Remove the rear body access panel.
3. Remove the two screws (5) from the speed controller cover (1) and remove the cover (**Figure 23-12, Page 23-13**).
4. Disconnect all wires and multi-pin connectors from the speed controller (**Figure 23-13, Page 23-14**).
5. Remove the three self-tapping screws (17) that hold the controller (6) to the component mounting plate and remove the controller from the vehicle.

Speed Controller Installation

1. Install the three self-tapping screws (17) that hold the controller (6) to the component mounting plate and tighten to 60 in-lb (6.8 N·m) (**Figure 23-13, Page 23-14**).
2. Using the wiring diagram, install the multi-pin connectors and all wires as illustrated. **See Wiring Diagram on page 21-2.** Tighten bolts (1) to 9 ft-lb (12.2 N·m) (**Figure 23-13, Page 23-14**).

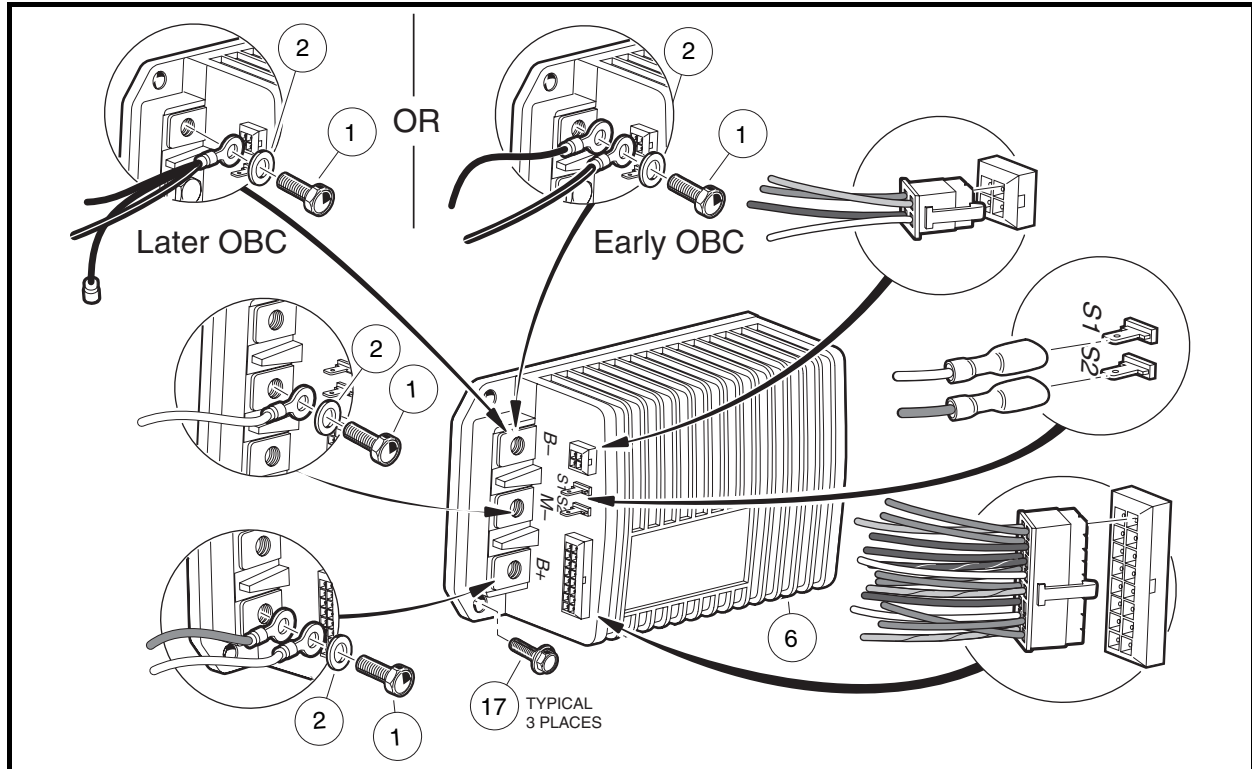

Figure 23-13 Speed Controller

3. Place the edge of the speed controller cover (1) into the slot (2). Press the controller cover onto the component mounting plate over the speed controller and install the two screws (5) (**Figure 23-12, Page 23-13**). Tighten the screws (5) to 60 in-lb (6.8 N·m). **See following NOTE.**

NOTE: Make sure that the speed controller cover gasket forms a tight seal between the cover and the component mounting plate.

4. Install rear body access panel.
5. Place the Tow/Run switch in the TOW position and connect the battery cables, positive (+) cable first. Tighten battery terminals to 110 in-lb (12.4 N·m) and coat terminals with Battery Terminal Protector Spray (CCI P/N 1014305) to minimize corrosion.
6. Place the Tow/Run switch in the RUN position.
7. Inspect the vehicle for proper operation:
 - Make sure that the vehicle operates in the forward direction when the Forward/Reverse switch is in the FORWARD position.
 - Make sure that the vehicle operates in the reverse direction when the Forward/Reverse switch is in the REVERSE position. The reverse buzzer will sound as a warning when the Forward/Reverse switch is in REVERSE.
 - Make sure that the vehicle does not operate when the Forward/Reverse switch is in the NEUTRAL position.

CHARGER RECEPTACLE

See General Warning on page 1-1.

The charger cord, plug, and receptacle are wear items and should be inspected daily. Visually inspect them for cracks, loose connections, and frayed wiring; they must be replaced when worn or damaged. If charger plug or receptacle show signs of corrosion or the plug is difficult to insert or remove, the receptacle contacts and plug terminals should be cleaned with a good electrical contact cleaner or lightly sprayed with WD-40® brand spray lubricant. The plug should then be inserted and removed several times to ensure ease of insertion, ease of removal, and good electrical contact.

Testing the Charger Receptacle

See Test Procedure 12, Section 21, Page 21-28.

See also the appropriate battery charger maintenance and service manual.

Charger Receptacle Inspection

Inspect the receptacle for cracks, loose connections and frayed wiring. **See following NOTE.**

***NOTE:** Disassembly of the charger receptacle, for the purpose of removal or installation, is not recommended.*

Charger Receptacle Removal

1. Disconnect the battery cables as instructed. **See WARNING “To avoid unintentionally starting...” in General Warning on page 1-2.**
2. Remove the 10-gauge red wire (4) from the positive post of battery no. 1 (**Figure 23-14, Page 23-16**).
3. Remove black 10-gauge OBC wire (5) from charger receptacle.
4. Disconnect the gray wire (9) from the receptacle at the yellow fuse holder.
5. Remove the four screws (1) that secure the charger receptacle bezel (7) to the receptacle backing plate (8) and to the vehicle body.
6. Move the receptacle assembly toward the front of the vehicle and tilt receptacle upwards in order for the receptacle to pass through the hole in the vehicle body.

Charger Receptacle Installation

1. Insert the 10-gauge red wire (4) and the 18-gauge gray wire (3) through the hole in the vehicle body and the receptacle backing plate (**Figure 23-14, Page 23-16**).
2. Insert receptacle into vehicle body.
3. Install the four screws (1) that secure the receptacle to the vehicle body and receptacle backing plate (8). Tighten screws to 16 in-lb (1.8 N·m).
4. Connect 18-gauge gray wire (9) to yellow fuse holder. Make sure fuse (11) is installed in fuse holder.
5. Connect the 10-gauge black wire (5) to the receptacle fuse link (6) on the charger receptacle (**Figure 23-14, Page 23-16**). Tighten to 23 in-lb (2.6 N·m).
6. Connect the 10-gauge red wire (4) to the positive post of battery no. 1.
7. Place the Tow/Run switch in the TOW position and connect the battery cables, positive (+) cable first. Tighten battery terminals to 110 in-lb (12.4 N·m) and coat terminals with Battery Terminal Protector Spray (CCI P/N 1014305) to minimize corrosion.

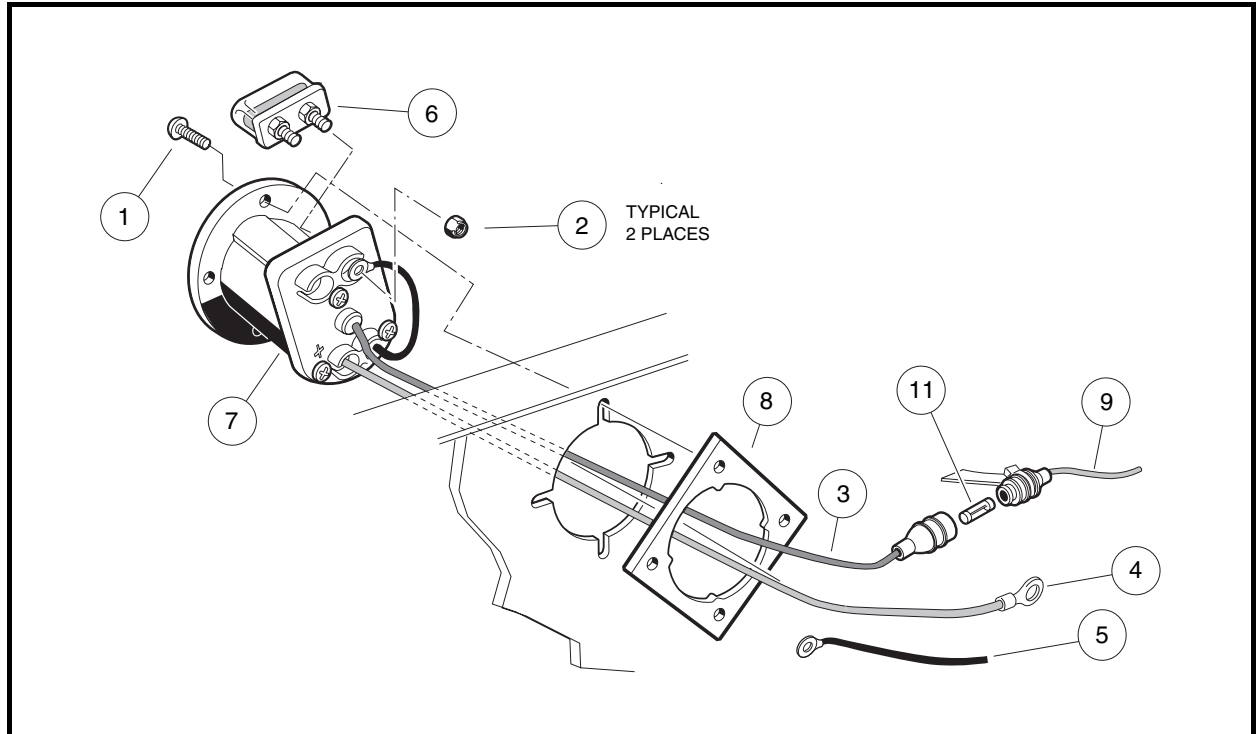

Figure 23-14 Charger Receptacle

RECEPTACLE FUSE LINK

The fuse link on the 48-volt electric vehicle should not blow under normal operating conditions; however, if the fuse link has blown, the vehicle will not charge and the fuse must be replaced. The fuse link (6) is mounted on top of the charger receptacle in the battery compartment (**Figure 23-14, Page 23-16**).

Receptacle Fuse Link Removal

1. Remove the fuse link (6) from the charger receptacle (7) by removing the two nuts and washers used to secure the 10-gauge black wire (5) from the computer and the 10-gauge black wire to the receptacle (**Figure 23-14, Page 23-16**).
2. Remove the fuse link (6) from the charger receptacle.

Receptacle Fuse Link Installation

1. Insert the two fuse link mounting posts into the mounting holes in the charger receptacle.
2. Place the two 10-gauge black wires in their original positions on the fuse link mounting posts. Tighten to 23 in-lb (2.6 N·m).
3. Install nuts (2) on fuse link mounting posts and tighten to 23 in-lb (2.6 N·m) (**Figure 23-14, Page 23-16**).

BATTERY WARNING LIGHT

See General Warning on page 1-1.

Testing the Battery Warning Light

See Test Procedure 18, Section 21, Page 21-32.

Battery Warning Light Removal

1. Disconnect the battery cables as instructed. See **WARNING “To avoid unintentionally starting...”** in **General Warning on page 1-2**.
2. Remove instrument panel. See **Key Switch Removal on page 23-1**.
3. Disconnect the two wires from the battery warning light.
4. Press the two retaining tabs (11) and remove the light from the instrument panel.

Battery Warning Light Installation

1. Install in reverse order of removal.
2. Place the Tow/Run switch in the TOW position and connect the battery cables, positive (+) cable first. Tighten battery terminals to 110 in-lb (12.4 N·m) and coat terminals with Battery Terminal Protector Spray (CCI P/N 1014305) to minimize corrosion.

SECTION 24 – BATTERIES: ELECTRIC VEHICLES

⚠ DANGER

- See General Warning on page 1-1.

⚠ WARNING

- See General Warning on page 1-1.

⚠ DANGER

- **Battery – Explosive gases! Do not smoke. Keep sparks and flames away from the vehicle and service area. Ventilate when charging or operating vehicle in an enclosed area. Wear a full face shield and rubber gloves when working on or near batteries.**
- **Charge batteries in a well-ventilated area only. Batteries emit hydrogen while being charged. Hydrogen is an explosive gas and must never exceed a level of 2% of the air.**
- **Battery – Poison! Contains acid! Causes severe burns. Avoid contact with skin, eyes, or clothing. Antidotes:**
 - **External: Flush with water. Call a physician immediately.**
 - **Internal: Drink large quantities of milk or water. Follow with milk of magnesia or vegetable oil. Call a physician immediately.**
 - **Eyes: Flush with water for 15 minutes. Call a physician immediately.**
- **Use insulated tools when working near batteries or electrical connections. Use extreme caution to avoid shorting of components or wiring.**

⚠ WARNING

- **Wear safety glasses or approved eye protection when servicing the vehicle or battery charger. Wear a full face shield and rubber gloves when working on or near batteries.**
- **Use insulated tools when working near batteries or electrical connections. Use extreme caution to avoid shorting of components or wiring.**
- **Ensure battery connections are clean and properly tightened. See Battery Care on page 24-9.**

CAUTION

- **On all electric vehicles, turn off all accessories before charging batteries.**

***NOTE:** Recycle or dispose of discarded batteries in accordance with local, state, and federal regulations.*

GENERAL INFORMATION

The batteries supplied with an electric vehicle are different from those supplied with an automobile. The outward appearance of these two batteries is similar, but the operating characteristics are very different. The electric vehicle battery is a deep-cycle battery, and the automotive battery is a “starting, lighting and ignition” (SLI) battery. They should never be substituted for one another. For gasoline vehicles, **see Battery on page 13-30 or Battery on page 14-30.**

BATTERY TROUBLESHOOTING CHART

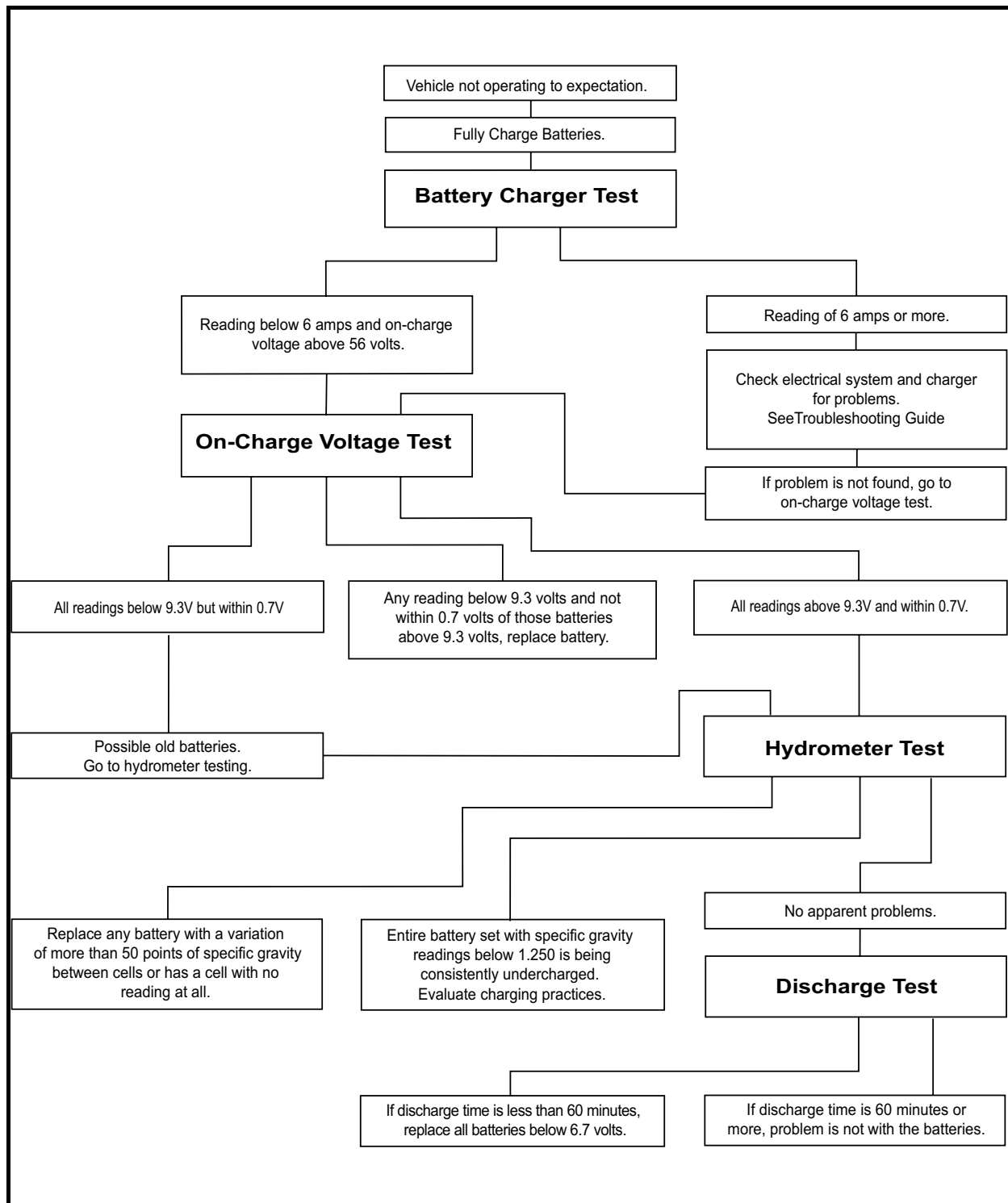

Figure 24-1 Battery Troubleshooting Chart

BATTERY TESTING

See **General Warning on page 1-1**.

Four tests have been developed to help diagnose problems with batteries that have not performed as expected. Because each test becomes progressively more detailed and time-consuming, begin with the first test and follow through with the other tests until the problem has been identified as outlined in the Battery Troubleshooting Chart (**Figure 24-1, Page 24-2**).

BATTERY CHARGER TEST

The easiest way to monitor the condition of a vehicle's batteries is simply to observe the reading on the battery charger ammeter at the end of the charge cycle. After a full charge, disconnect the charger DC plug, wait 20 to 30 seconds and reconnect the charger DC plug. The ammeter needle will jump to 15 amps or more and then taper to below 6 amps within 10 to 20 minutes, indicating sound, fully charged batteries.

Continued poor performance may indicate a problem in the vehicle electrical system, brakes or battery charger. If the problem is not found in the vehicle or charging system, proceed to the on-charge voltage test. Batteries that remain at 8 amps or higher should be tested further using the on-charge voltage test.

ON-CHARGE VOLTAGE TEST

When the batteries are fully charged, disconnect the charger DC plug. Wait 20 to 30 seconds and reconnect the DC plug to restart the charger. After 5 minutes, use a multimeter to check and record the voltage of the battery set as well as the individual batteries. Set the multimeter to 200 volts DC. Place the red (+) probe on the positive (+) post of battery no. 1 and the black (-) probe on the negative (-) post of battery no. 4 (**Figure 24-4, Page 24-9**). Record reading. Then set multimeter to 20 volts DC and place the red (+) probe on the positive (+) post and the black (-) probe at the negative (-) post of each battery. Record the readings.

The on-charge voltage for the set should be between 56.0 volts and 63.0 volts depending on the age and state of charge of the batteries being tested. If individual batteries read above 14.0 volts and are within 1.0 volts of each other, go to the hydrometer test. If any battery reads below 14.0 volts and not within 1.0 volts of those batteries above 14.0 volts, replace battery. If readings are below 14.0 volts but within 1.0 volts of each other, the batteries are old. Old batteries may have enough capacity left to last several more months. Go to hydrometer test. **See Battery Troubleshooting Chart on page 24-2 and the examples on the following pages.**

HYDROMETER TEST

A hydrometer measures the specific gravity of the battery's electrolyte. The higher the specific gravity, the higher the state of charge of the batteries. A fully charged battery should read between 1.250 and 1.280 at 80 °F (26.7 °C). Never add acid to batteries to obtain a higher specific gravity.

Performing the Hydrometer Test

1. Be sure batteries have sufficient electrolyte to cover plates by approximately 1/2 inch (13 mm) and are fully charged prior to beginning test. If water must be added, recharge the batteries before performing the hydrometer test.
2. Remove the vent cap. Using a battery thermometer (CCI P/N 1011767), record electrolyte temperature of the no. 2 cell.
3. Squeeze the rubber bulb of the hydrometer and insert into the cell. Slowly release the bulb, drawing electrolyte up into the glass tube of the hydrometer.

4. When the float rises off the bottom, adjust the electrolyte level so that the float rides free of the bottom but does not strike the top of the glass tube. Remove the hydrometer from the cell and release the pressure from the bulb.
5. Hold the hydrometer vertically, ensuring that the float is not touching the sides of the barrel. Hold the hydrometer at eye level and read the scale at the level of electrolyte (**Figure 24-2, Page 24-4**).
6. Record the reading and return the electrolyte to the cell from which it was taken. Replace vent cap.
7. Repeat steps 2 through 6 on all cells.

Hydrometer Calibration

Most hydrometers are calibrated to read correctly at 80 °F (26.7 °C). The readings obtained as described above must be corrected for temperature. For each 10 °F (5.6 °C) above 80 °F (26.7 °C), add 0.004 to the reading. For each 10 °F (5.6 °C) below 80 °F (26.7 °C), subtract 0.004 from the reading.

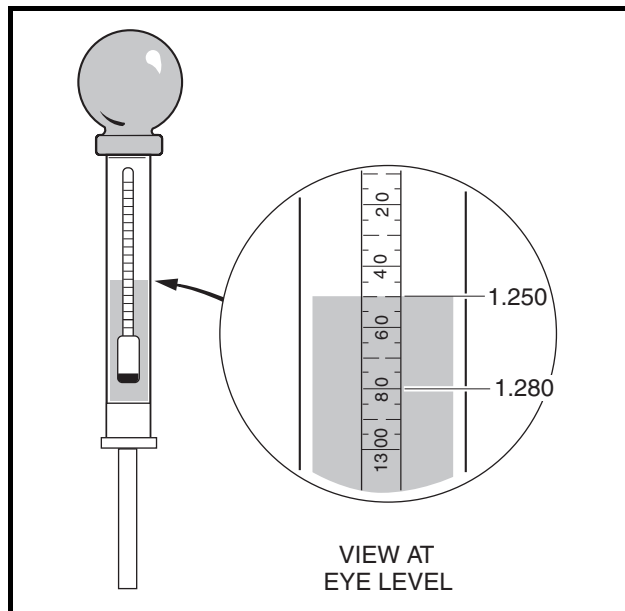

Figure 24-2 Hydrometer

Interpreting the Results of the Hydrometer Test

The approximate state of charge can be determined from the following table:

SPECIFIC GRAVITY (TEMPERATURE CORRECTED)	APPROXIMATE STATE OF CHARGE
1.250-1.280	100%
1.220-1.240	75%
1.190-1.210	50%
1.160-1.180	25%

If the difference between the cells is 0.020 or more, the low cell should be suspected. It may require a catch-up charge or it may be a weak cell. When the variations between cells reach 0.050 or more, the battery with the low cell should be replaced.

VEHICLE NO.	BATTERY NO.	ELECTROLYTE TEMPERATURE	CORRECTION FACTOR	CORRECTED SPECIFIC GRAVITY						REQUIRED ACTION
				CELL 1	CELL 2	CELL 3	CELL 4	CELL 5	CELL 6	
12	1	20 °F (-6.6 °C)	-0.024	1.275 - 0.024 = 1.251	1.280 - 0.024 = 1.256	1.280 - 0.024 = 1.256	1.275 - 0.024 = 1.251	1.280 - 0.024 = 1.256	1.280 - 0.024 = 1.256	Sound Battery – Fully Charged
54	3	50 °F (10 °C)	-0.012	1.260 - 0.012 = 1.248	1.200 - 0.012 = 1.188	1.270 - 0.012 = 1.258	1.265 - 0.012 = 1.253	1.270 - 0.012 = 1.258	1.260 - 0.012 = 1.248	Bad no. 2 Cell
38	2	100 °F (37.8 °C)	+0.008	1.200 + 0.008 = 1.208	1.180 + 0.008 = 1.188	1.170 + 0.008 = 1.178	1.200 + 0.008 = 1.208	1.180 + 0.008 = 1.188	1.198 + 0.008 = 1.198	Discharged Battery – Recharge and Recheck
22	4	80 °F (26.7 °C)	.000	1.240 - 0 = 1.240	1.245 - 0 = 1.245	Float does not rise	1.235 - 0 = 1.235	1.250 - 0 = 1.250	1.240 - 0 = 1.240	no.3 Cell Dead – Replace Battery

DISCHARGE TEST

If the previous tests have failed to identify the problem, conduct a discharge test. The discharge test comes closest to simulating actual vehicle operating conditions by continuously drawing current from the batteries until voltage drops to 42.0 volts.

The discharge test is the hardest test on the batteries and the most time-consuming to perform. Use the battery discharge tester (CCI P/N 101831901).

Performing the Discharge Test

1. Be sure the batteries are fully charged and that the electrolyte level is correct in all cells.
2. Connect the tester leads to the positive (+) post of battery no.1 and negative (-) post of battery no. 4 (Figure 24-3, Page 24-5).

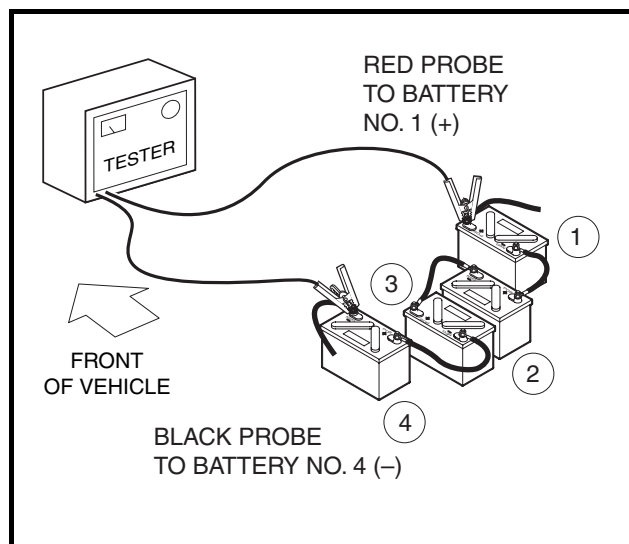

Figure 24-3 Battery Discharge Test

3. Check and record the electrolyte temperature of the battery packs. Check cell no. 2 (second cell from positive post) in each battery.
4. Reset discharge machine and turn the tester ON.
5. When the batteries have been discharging for approximately 60 minutes, set the discharge machine to function 3 and check battery set voltage. Check voltage every 10 minutes throughout the rest of the test. As soon as the battery set voltage reaches 0.5 volts above the shut-off point (42.0 volts), use a multimeter to measure individual battery voltages. Measure and record the voltage of each battery to the nearest 0.01 volt. **See following NOTE.**

NOTE: The tester will shut off automatically when shut-off voltage is reached.

Interpreting Discharge Test Results

1. If discharge time is 60 minutes or higher, the problem is not with the batteries.
2. If discharge times are low (less than 60 minutes), replace batteries below 10.05 volts.

BATTERY VOLTAGES				BATTERY CONDITION
1	2	3	4	
10.50 V	10.50 V	10.50 V	10.50 V	Excellent
10.60 V	10.60 V	10.83 V	9.75 V	Battery no. 4 is near end of useful life
10.8 V	10.8 V	10.01 V	9.41 V	Battery nos. 3 and 4 are near end of useful life

3. In general, battery sets that discharge in less than 60 minutes at 78 °F (25.6 °C) on the discharge test will typically not hold a charge for an entire work shift. However, discharge time is dependent on the electrolyte temperature. The table shown gives the discharge times, at various temperatures, of a set of batteries that delivers 62 minutes at 80 °F (26.7 °C).

ELECTROLYTE TEMPERATURE	DISCHARGE TIME TO SHUT-OFF POINT	ELECTROLYTE TEMPERATURE	DISCHARGE TIME TO SHUT-OFF POINT
40-49 °F (4-9 °C)	40 Minutes	85-89 °F (29-32 °C)	64 Minutes
50-59 °F (10-15 °C)	45 Minutes	89-99 °F (32-37 °C)	66 Minutes
60-64 °F (16-18 °C)	50 Minutes	100-109 °F (38-43 °C)	68 Minutes
65-69 °F (18-21 °C)	54 Minutes	110-119 °F (43-48 °C)	70 Minutes
70-74 °F (21-23 °C)	57 Minutes	120-129 °F (49-54 °C)	72 Minutes
75-79 °F (24-26 °C)	60 Minutes	130-150 °F (54-66 °C)	74 Minutes
80-84 °F (27-29 °C)	62 Minutes	*****	*****

BATTERY TROUBLESHOOTING EXAMPLES

The following information represents a few examples of troubleshooting battery problems.

Example 1

Vehicle no. 68 was suspected of having a bad battery due to its performance. As a result, the battery charger test was performed. After a full charge, the battery charger ammeter read 8.0 amps. Next, the on-charge voltage test was performed and the following results were recorded:

BATTERY NO.	1	2	3	4
On-Charge Voltage	15.22 V	15.90 V	14.70* V	15.24 V

*Battery no. 3 appears suspect. Battery nos. 1 and 4 are also suspect. Next, a hydrometer test should be conducted on all batteries.

Hydrometer test results:

CELL NUMBER	BATTERY NUMBER			
	1	2	3	4
Cell 1 (Positive Post)	1.200*	1.265	1.300	1.250
Cell 2	1.285	1.275	1.290	1.270
Cell 3	1.265	1.270	1.275	1.265
Cell 4 (Negative Post)	1.275	1.270	1.285	1.265
Cell 5	1.270	1.265	1.280	1.270
Cell6	1.275	1.280	1.280	1.260

*After the hydrometer test, it appears that battery no. 1 is the problem. Next, the discharge test was performed.

Discharge test results:

BATTERY NO.	1	2	3	4
Discharge Voltage	8.16* V	10.99 V	11.60 V	10.72 V

*After a discharge test which lasted 45 minutes, battery no. 1 is clearly shown to be the problem. Battery no. 4 should be watched a little more closely but appears to be okay. Battery no. 1 should be replaced with a battery that has about the same age and usage as the other batteries in the set.

Example 2

Vehicle no. 70 was also suspected of having a bad battery due to its performance. The battery charger test showed 7.0 amps after a full charge. After confirming there were no problems with the electrical system, charger or brakes, the on-charge voltage was recorded as follows:

BATTERY NO.	1	2	3	4
On-Charge Voltage	15.72 V	14.66* V	15.80 V	15.85 V

*Battery no. 2 was immediately suspected as the problem. After checking battery no. 2 with a hydrometer, it was discovered that the negative post cell was completely dead. Battery no. 2 should be replaced with a battery that has the same age and usage as the other batteries in the set.

BATTERY REPLACEMENT

See General Warning on page 1-1.

⚠ WARNING

- To prevent electrolyte leakage from the battery vents, batteries must be kept in an upright position. Tipping a battery beyond a 45° angle in any direction can allow a small amount of electrolyte to leak out the vent hole. Do not exceed this 45° angle when lifting, carrying, or installing batteries. Battery acid can cause severe personal injury to skin or eyes, and can damage clothing.
4. Before removing batteries, note the orientation of the batteries and the connecting wires. Disconnect the battery cables as instructed. **See WARNING “To avoid unintentionally starting...” in General Warning on page 1-2.** Remove remaining wires and batteries. **See Wiring Diagram on page 21-2.**
 5. Visually inspect the new batteries for any damage that may have occurred in transit. New batteries will not deliver their full capabilities until they have been discharged and recharged 20 to 50 times. To obtain the maximum service life from new batteries, restrict vehicles with new batteries to one hour of operation between charges for the first two months vehicle is in service. Batteries should be fully charged before first use of new vehicle, before first use of a vehicle after storage, and before use each day.
 6. If the battery cables are to be reused, inspect them for broken or frayed wires, damaged terminals, or worn insulation. Remove any corrosion on the connectors. A solution of baking soda and water (1 cup (237 mL) baking soda per 1 gallon (3.8 L) of water) does an excellent job of neutralizing and removing the corrosion. Be careful not to allow the baking soda solution to enter the battery.
 7. Check and clean the battery rack and hold-downs. The nuts and bolts on the hold-downs may corrode. It is therefore advised they be cleaned periodically and replaced as necessary.
 8. Install batteries in the proper orientation (**Figure 24-4, Page 24-9**). Install battery hold-downs. The hold-downs should be tight enough so batteries do not move while vehicle is in motion, but not so tight as to crack or buckle battery case. Tighten to 40 in-lb (4.5 N·m), alternating between hold-down bolts.
 9. Install wires in proper sequence (**Figure 24-4, Page 24-9**). Install black wire to negative post of battery no. 4 last. Tighten all connections to 110 in-lb (12.4 N·m). Coat all terminals with Battery Terminal Protector Spray (CCI P/N 1014305) to minimize future corrosion.
 10. Give the batteries a full charge prior to operation. This ensures all the batteries are fully charged and the cells are equalized prior to use.

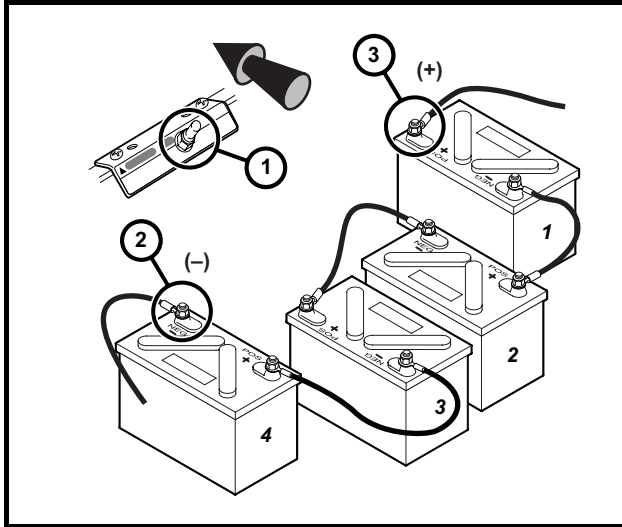

Figure 24-4 IQ System Electric Vehicle - 12-Volt Battery Configuration

(Viewed from driver side of vehicle)

1. Place TOW/RUN Switch in TOW before disconnecting or connecting battery cables.
 2. Remove negative battery cable.
 3. Remove positive battery cable.
- Connect battery cables in reverse order.

BATTERY CARE

See General Warning on page 1-1.

PREVENTIVE MAINTENANCE

To keep batteries in sound operating condition, follow these steps on a regular basis.

1. Any corrosion build-up on or around batteries should be removed immediately. Terminal connections should be clean and tight. Any frayed or worn wires should be replaced. After all cables have been connected, coat all terminals with Battery Terminal Protector Spray (CCI P/N 1014305) to help prevent future corrosion.
2. Batteries should be clean and free of corrosion. Wash tops and terminals of batteries with a solution of baking soda and water (1 cup (237 mL) baking soda per 1 gallon (3.8 L) of water). Rinse solution off batteries. Do not allow this solution to enter the batteries. Be sure terminals are tight. Let the terminals dry and then coat them with Battery Terminal Protector Spray (CCI P/N 1014305). **See Self-Discharge on page 24-10.**
3. Maintain proper electrolyte level. **See Electrolyte Level on page 24-10.**
4. Batteries should be properly charged every day they are used. Check the batteries periodically to see that they are in a full state of charge. **See Battery Charger on page 24-12.**
5. Keep hold-downs tight. **See Vibration Damage on page 24-11.**

SELF-DISCHARGE

Contaminants on dirty batteries can provide a path for a small current draw that can slowly discharge batteries, thus wasting valuable energy. To prevent self-discharge, batteries should always be kept clean.

Hot weather also has an effect on a battery's self-discharge rate. The higher the temperature, the quicker a set of batteries will discharge. In hotter climates, batteries should be checked more often. When storing batteries, keep in a cool place. **See Battery Storage on page 24-15.**

ELECTROLYTE LEVEL

⚠ CAUTION

- **Do not allow battery acid from battery caps or hydrometer to drip onto the front or rear body of the vehicle. Battery acid will cause permanent damage. Wash immediately.**

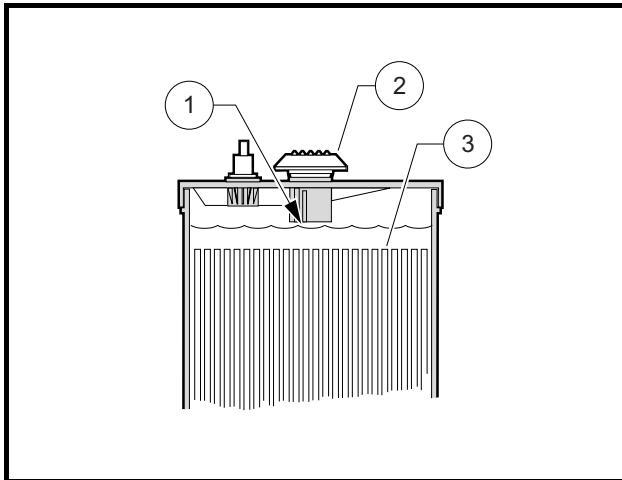

Figure 24-5 Battery Electrolyte Level

1. Level Indicator 2. Cap 3. Plates

Electrolyte level at least 1/2 inch (13 MM) above plates or to level indicator.

Add water only after charging unless the electrolyte is below the level of the plates. If the electrolyte level is below the level of the plates, add just enough water to cover the plates and then charge the batteries. After charging, fill with water to the level indicator. Filling a battery to the level indicator before charging will result in overfilling because the electrolyte level will rise during charging and some of the electrolyte may bubble out of the cap. This reduces the battery's capacity and corrodes the metal parts around it.

The electrolyte level should be checked weekly to be sure electrolyte is at its proper level (**Figure 24-5, Page 24-10**). Never allow the electrolyte level to fall below the tops of the plates because this will cause the exposed part of the plate to become permanently inactive. For best results, use a battery watering gun to add water to batteries. Check the electrolyte level more frequently in hot weather or when batteries are old.

MINERAL CONTENT

For the longest battery life, use distilled water in batteries. However, if tap water is to be used, be sure the mineral contents are below these levels:

IMPURITY	ALLOWABLE CONTENT (PARTS PER MILLION)
Suspended matter	Trace
Total solids	100.0
Calcium and Magnesium Oxides	40.0
Iron	5.0
Ammonia	8.0
Organic matter	50.0
Nitrates	10.0
Nitrites	5.0
Chloride	5.0

VIBRATION DAMAGE

The battery hold-downs should always be tight enough to keep the battery from bouncing. Battery life may be severely shortened if the battery hold-downs are too loose. Battery hold-downs should be tightened to 40 in-lb (4.5 N·m). Excessive vibration causes the plates to shed prematurely and shortens the life of the battery. It may also cause acid to leak out of the vent caps and corrosion to build up on surrounding metal parts. The acid which is lost reduces the capacity of the battery and cannot be replaced. Battery hold-downs should NOT be so tight as to crack or buckle the battery case. This may cause leaks which would dry out a cell or cause internal short circuits. **See Battery Replacement on page 24-8.**

BATTERY CHARGER

See General Warning on page 1-1.

The charger supplied with the electric vehicle resolves the most common problems associated with battery charging. Undercharging and overcharging are prevented provided the charger is allowed to shut off by itself. Also, all cells are automatically given an equalization charge at low current, which prolongs battery life. Batteries should never be left in a discharged state, as this too affects the internal components and can reduce the capacity of the battery. The batteries should be charged every day they are used. However, the batteries should not be charged if they have not been used.

CHARGING BATTERIES

⚠ WARNING

- Be sure all wire connections at the receptacle and the fuse link are clean and tight.
- Do not rock or bend the plug. To connect the charger plug to the vehicle receptacle, grasp the plug handle and push the plug straight into the receptacle (Figure 24-6, Page 13).
- Do not pull on the DC cord (Figure 24-7, Page 24-13). Do not twist, rock or bend the plug. To disconnect the charger plug from the vehicle receptacle, grasp the plug by the handle and pull the plug straight out of the receptacle.
- Do not connect a charger to the receptacle if the charger cord, plug, or the vehicle receptacle is broken, damaged in any manner, or does not make a good electrical connection. Fire or personal injury can result. Have it replaced by a qualified service person immediately.
- Failure to follow these instructions could result in damage to the charger cord, the plug, and (or) the vehicle receptacle.
- Do not use a charger if:
 - The plug is too loose or does not make a good connection.
 - The plug and receptacle feel hotter than normal during charge.
 - The plug pins or receptacle contacts are bent or corroded.
 - The plug, receptacle, or cords are cut, worn, have any exposed wires or are damaged in any way.
- Using the charger with any of the above symptoms could result in a fire, property damage, personal injury, or death.

NOTE: When temperatures fall below 18.3 °C (65 °F), batteries charged in unheated areas should be placed on charge as soon as possible after use. Batteries are warmest immediately after use, and cold batteries require more time to fully charge.

Insert the charger DC plug into the vehicle receptacle. The charger will turn on two to ten seconds later (Figure 24-6, Page 24-13).

When inserting the DC plug, align the raised guide on the plug with the guide slot in the receptacle and push straight in slowly.

Club Car battery chargers interact with the vehicle's onboard computer. The computer records the amount of energy consumed during vehicle use. While the charger is plugged in, the vehicle's control circuit is locked out, preventing operation of the vehicle as well as the possibility of consequent damage to the charger and the vehicle.

Once the lockout is actuated, the charger turns on. The onboard computer then records the amount of energy being returned to the batteries. When the optimum amount of energy needed to replenish the batteries is returned, the charger will shut off. The control circuit lockout remains activated until the charger plug is disconnected from the vehicle.

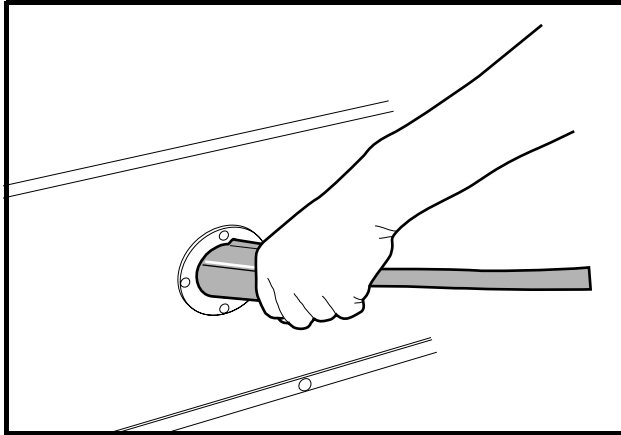

Figure 24-6 Correct Insertion of Charger DC Plug

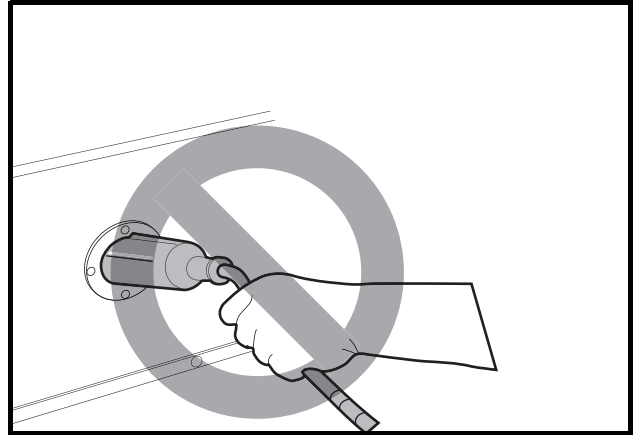

Figure 24-7 Incorrect Insertion of Charger DC Plug

Electric vehicles are supplied with a PowerDrive or PowerDrive 3 battery charger. Use only the PowerDrive family of chargers with this electric vehicle.

As long as the charger is allowed to shut off by itself, the batteries will be fully charged. Overcharging and undercharging will normally be prevented.

Batteries should be put on charge even if they have been used for only a short period (10 minutes). The charger is automatic and will turn off when batteries are fully charged. If the charger does not seem to be operating properly, or if the batteries seem weak, contact your local Club Car distributor/dealer.

PLUG AND RECEPTACLE

The charger cord, plug, and receptacle are wear items and should be inspected daily. Visually inspect them for cracks, loose connections, and frayed wiring; they must be replaced when worn or damaged. If charger plug or receptacle show signs of corrosion or the plug is difficult to insert or remove, the receptacle contacts and plug terminals should be cleaned with a good electrical contact cleaner or lightly sprayed with WD-40[®] brand spray lubricant. The plug should then be inserted and removed several times to ensure ease of insertion, ease of removal, and good electrical contact. **See following NOTE.**

NOTE: *If the warning tag has been damaged or removed from the DC cord, have it replaced immediately.*

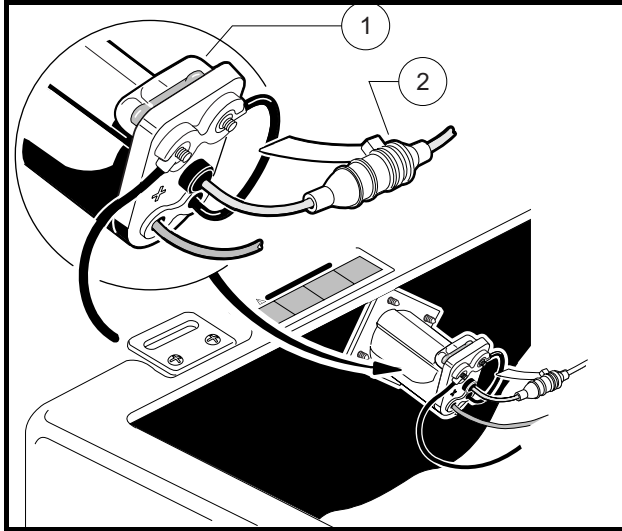

Figure 24-8 Receptacle Fuse Link

1.Fuse Link 2. Sense Lead Fuse

RECEPTACLE FUSE LINK

As an additional feature to protect the batteries and charging circuit from an overload, the electric vehicle is equipped with a receptacle fuse link (**Figure 24-8, Page 24-14**). If the charger does not come on when the vehicle is placed on charge, visually inspect the fuse link. **See following WARNING.**

⚠ WARNING

- If the receptacle fuse link is blown, determine the source of the electrical problem and correct it before replacing the fuse. Contact your nearest Club Car distributor/dealer.

CHARGER SHUTS OFF AFTER 16 HOURS

This may be due to 1) new batteries, 2) hard use, or 3) cold temperatures. A catch-up charge may be necessary when these conditions are present. On those days when all or some of the vehicles do not get used, check the batteries for state of charge. Any battery with a specific gravity lower than 1.250 will need a catch-up charge. If the problem continues after a catch-up charge has been performed, check the battery charger. Refer to the appropriate battery charger maintenance and service manual. **See Section 25 – Battery Charger: Electric Vehicle.**

DEEP-DISCHARGE

Never discharge batteries to the point the vehicle will no longer operate. This will considerably shorten the cycle life of the batteries, and may permanently damage the batteries. It is possible the batteries will not accept a charge if they are completely discharged. The deeper the discharge, the harder it is on the batteries. For this reason, it is recommended that electric vehicle batteries be charged after each use (provided the charge cycle will not be interrupted and the charger will be allowed to shut off automatically). Placing the batteries on charge after each use reduces the depth of discharge and prolongs battery life.

EARLY EXCESSIVE DISCHARGING

When vehicle batteries are new, they do not reach their full capacity until they have been used and recharged 20 to 50 times. If they are excessively discharged early in their life, their effective service life will be shortened. It is advisable to limit the use of any vehicle with new batteries for at least the first four weeks and then gradually increase their range.

INCOMING AC SERVICE

Make sure the incoming AC line service is sufficient. If circuit breakers are tripping, fuses blow during the night or the charger does not give the required starting rate when sound batteries are put on charge, an AC line problem exists. The electrical service to the vehicle storage facility should be sufficient to deliver adequate voltage and current to each charger with all the chargers turned on. If not, consult your local power company or electrical contractor. Refer to the appropriate battery charger maintenance and service manual. **See Section 25 – Battery Charger: Electric Vehicle.**

FLEET ROTATION

Rotate vehicle usage. It is very hard on batteries if the last vehicles in at night are the first ones out in the morning. Spread the workload evenly, giving all vehicles the same amount of use. This will keep your fleet in balance and will not overwork certain sets of batteries. **See following NOTE.**

NOTE: *When vehicles are being rotated, the CDM (Communication Display Module) can be a very helpful service tool. Monitoring the value of function 3 with the CDM simplifies vehicle usage scheduling. See Communication Display Module (CDM), Section 21, Page 21-33.*

NUMBERING VEHICLES AND CHARGERS

Return the vehicles to the same charger each night if possible. If the vehicles are put in a storage facility at random and a vehicle dies while in use and testing shows the batteries are sound, then the problem is most likely with the charger. However, finding the problem charger may prove to be quite time consuming. Numbering the vehicles and the chargers and returning each vehicle to its designated charger each night can significantly reduce the amount of time spent troubleshooting a problem.

BATTERY STORAGE

See General Warning on page 1-1.

When storing batteries during the off-season or when maintaining a replacement stock, follow these guidelines:

1. Keep the batteries clean and free of corrosion. **See Battery Care on page 24-9.**
2. Batteries that are in vehicles for winter storage should be left disconnected in the vehicles if the batteries are not going to be connected to a charger.
3. Fully charge the batteries prior to storage.

4. Store in a cool area. The colder the area in which the batteries are stored, the less the batteries will self-discharge. Batteries stored at 0 °F (−17.8 °C) will discharge very little over a four-month period. Batteries stored at 80 °F (26.7 °C) will have to be recharged every few weeks.
5. 48-volt electric vehicles and compatible battery chargers are designed to be left connected, with AC power to the charger ON, during off-season storage. The storage charge feature will automatically charge the batteries as needed throughout the storage period.

CHARGING A BATTERY PACK THAT HAS LOW VOLTAGE

See the appropriate battery charger maintenance and service manual.

SECTION 25 – BATTERY CHARGER: ELECTRIC VEHICLE

Refer to the appropriate Battery Charger Maintenance and Service Manual.

SECTION 26 – MOTOR (MODEL 5BC59JBS6390)

DANGER

- See General Warning on page 1-1.

WARNING

- See General Warning on page 1-1.

GENERAL INFORMATION

The electric vehicle is equipped with a 48-volt DC, shunt-wound, reversible traction motor. The shunt-wound motor is designed for use on electric vehicles only. It is recommended that motors requiring major repair be sent to a qualified motor repair shop; however, there are many relatively simple tasks that can be performed by a technician with general knowledge and experience in electric motor repair.

MOTOR IDENTIFICATION

There are two types of motors used in this electric vehicle: Model 5BC59JBS6390 (gray housing), and EJ4-4001 (black housing). Do not attempt to service a motor that has not been properly identified. If the motor cannot be properly identified, contact your local dealer or distributor.

EXTERNAL MOTOR TESTING

The following tests can be performed without disassembling the motor using a multimeter or continuity tester.

***NOTE:** Tag the motor wires for identification before disconnecting.*

TEST PROCEDURE 1 – INTERNAL SHORT CIRCUITS

See General Warning on page 1-1.

1. Disconnect the battery cables as instructed. See **WARNING “To avoid unintentionally starting...” in General Warning on page 1-2.**
2. Disconnect wires from terminals on motor using two wrenches to prevent posts from turning.
3. With a multimeter set to 200 ohms, place black (–) probe on motor housing. Scratch through paint to ensure a good connection. Place red (+) probe on A1, A2, F1, and F2 terminals respectively. Multimeter should indicate no continuity between the motor housing and all individual terminals. If readings are incorrect, motor will need to be removed from the vehicle and repaired by a qualified technician. See **Motor Removal on page 26-2.**
 - 3.1. An incorrect reading from the A1 or A2 terminal indicates three possible problems: a grounded A1 or A2 terminal, a grounded wire in the brush area, or a grounded armature/commutator. An incorrect reading for the F1 or F2 terminal indicates a possible grounded F1 or F2 terminal or field coil.

TEST PROCEDURE 2 – ARMATURE CIRCUIT OPEN

See General Warning on page 1-1.

1. Disconnect the battery cables as instructed. See **WARNING “To avoid unintentionally starting...”** in **General Warning on page 1-2.**
2. Disconnect wires from the A1 and A2 terminals on the motor using two wrenches to prevent posts from turning. Set a multimeter to 200 ohms and place the red (+) probe on the A1 motor terminal and black (–) probe on the A2 motor terminal. The multimeter should indicate continuity. If the reading is incorrect, a possible open or poor contact in a brush assembly and/or open armature windings may be the cause. The motor will need to be removed from the vehicle and repaired by a qualified technician. See **Motor Removal on page 26-2.**

TEST PROCEDURE 3 – FIELD CIRCUIT OPEN

See General Warning on page 1-1.

1. Disconnect the battery cables as instructed. See **WARNING “To avoid unintentionally starting...”** in **General Warning on page 1-2.**
2. Disconnect wires from the F1 and F2 terminals on the motor using two wrenches to prevent posts from turning. Set a multimeter to 200 ohms and place the red (+) probe on the F1 terminal and the black (–) probe on the F2 terminal. The multimeter should indicate continuity. If the reading is incorrect, a possible open field coil or bad connections at the terminals may be the cause. The motor will need to be removed from the vehicle and repaired by a qualified technician. See **Motor Removal on page 26-2.**

MOTOR

See General Warning on page 1-1.

Motor Removal

1. Disconnect the battery cables as instructed. See **WARNING “To avoid unintentionally starting...”** in **General Warning on page 1-2.**
2. Disconnect wires from the terminals on the motor using two wrenches to prevent posts from turning. Label the wires to ensure proper reconnection.
3. Slightly loosen all the lug nuts on both rear wheels.
4. Place floor jack under transaxle and raise rear of vehicle (**Figure 26-1, Page 26-3**) then place jack stands under frame crossmember between the spring mount and the side stringer, just forward of each rear wheel. Lower the vehicle to let the jack stands support the vehicle (**Figure 26-2, Page 26-3**). See following **WARNING**.

WARNING

- Lift only one end of the vehicle at a time. Use a suitable lifting device (chain hoist or hydraulic floor jack) with 1000 lb. (454 kg) minimum lifting capacity. Do not use lifting device to hold vehicle in raised position. Use approved jack stands of proper weight capacity to support the vehicle and chock the wheels that remain on the floor. When not performing a test or service procedure that requires movement of the wheels, lock the brakes.

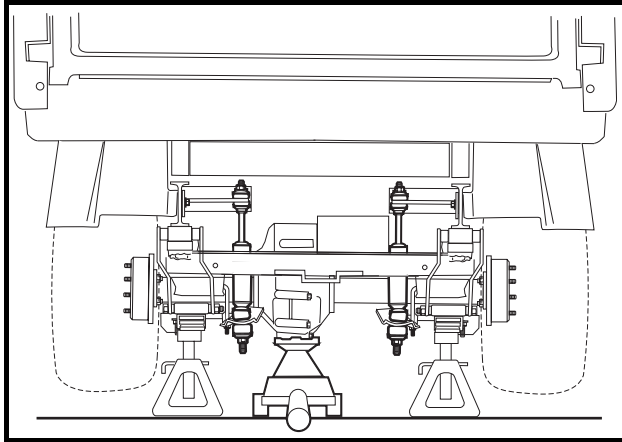

Figure 26-1 Lift Vehicle with Floor Jack

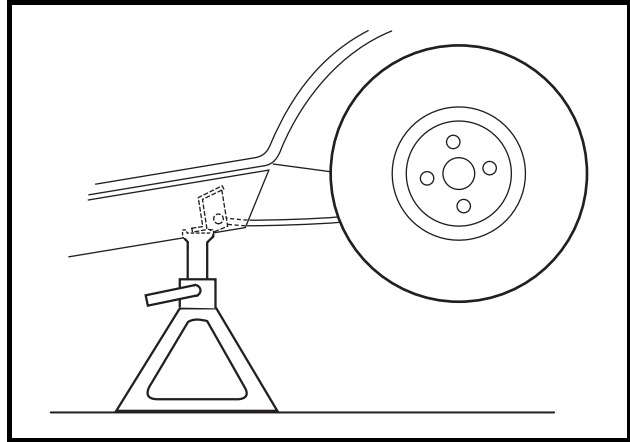

Figure 26-2 Vehicle Supported on Jack Stands

5. Remove both rear wheels.
6. Remove the nut, cup washer, and bushing from the bottom side of the shock absorber. Compress the shock absorber (pushing upwards) to move it out of the way (**Figure 26-3, Page 26-3**).
7. Remove the nuts and bolts mounting the rear leaf springs to the shackles.
8. To gain easier access to the motor, lower the transaxle as low as it will go. If more room is needed, remove the jack from beneath the transaxle and allow the springs to rest on the floor (**Figure 26-3, Page 26-3**).

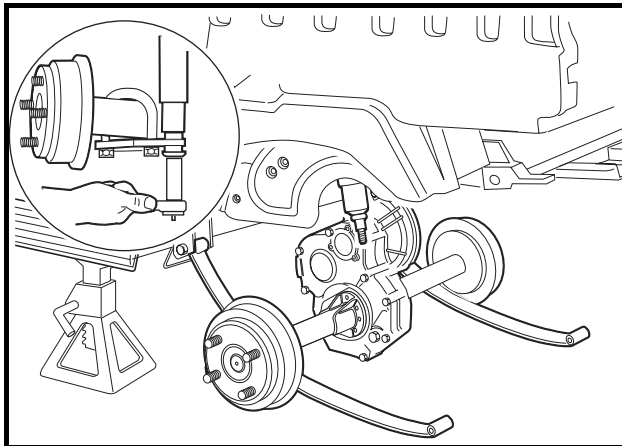

Figure 26-3 Lower Axle

9. Remove the four bolts that mount the motor to the transaxle (**Figure 26-18, Page 26-14**). See following **CAUTION**.

⚠ CAUTION

- Do not position fingers under motor when sliding motor off of the input shaft in step 9. Fingers may get pinched when motor disengages.

10. Carefully slide the motor away from the transaxle until the motor spline disengages the input shaft and remove the motor from the vehicle.

Motor Disassembly

1. Before beginning disassembly, place match marks on the motor end shield and stator shell, then place the motor in a vice with wooden blocks as shown (**Figure 26-4, Page 26-4**).
2. Remove the four bolts (8) securing the end shield (10) to the stator shell (2).
3. Remove the two screws (9) attaching the end shield to the bearing retainer.
4. Slide the armature (17) out of the opposite end of the stator shell (2).
5. Remove two screws (11) attaching brush rigging (12) to the stator shell (2) (**Figure 26-9, Page 26-8**).
6. Mark the brush terminal posts (A1 and A2) (13) to identify their positions in the stator shell, then remove the nuts (6) and flat washers (5) (**Figure 26-9, Page 26-8**). From the outside, push the posts through the stator shell wall into the interior of the stator shell.
7. Carefully remove the brush rigging and the terminal posts from the stator shell.
8. To remove brush springs (14) from the rigging, lift the spring extensions out and over the brush mounts and then slide the springs off their mounting tabs (**Figure 26-5, Page 26-4**).

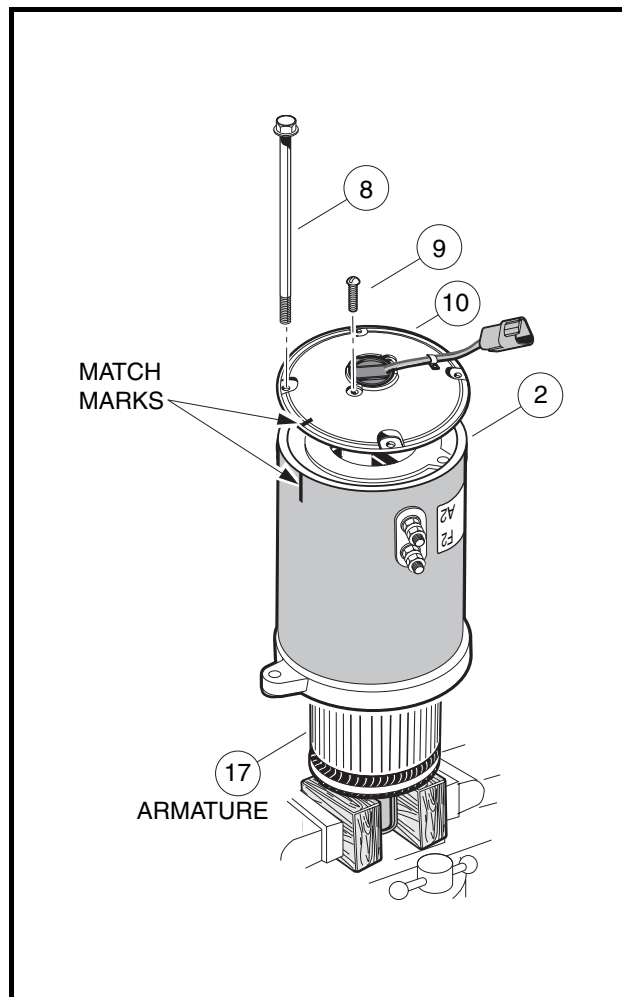

Figure 26-4 Motor Disassembly

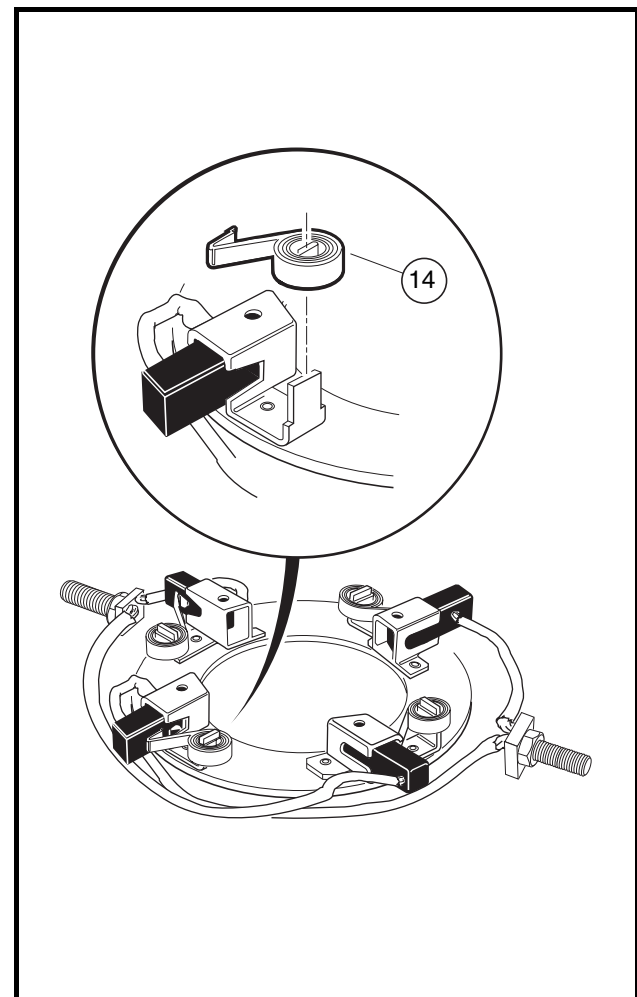

Figure 26-5 Brush Spring Removal

MOTOR COMPONENT TESTING AND INSPECTION

See General Warning on page 1-1.

ARMATURE

Visual Inspection

Disassemble the motor and carefully inspect the armature for the following characteristics:

- Burned, charred or cracked insulation
- Improperly cured varnish
- Thrown solder
- Flared armature windings
- Damaged armature core laminations
- Worn, burned or glazed commutators
- Dirty or oily commutators
- Raised commutator bars
- Worn armature bearing or shaft

A dirty or oily commutator should be cleaned and wiped dry. Abnormalities identified during the inspection can help determine original cause of failure. Slight roughness of the commutator can be polished smooth with 400 grit or finer sandpaper. **See following CAUTION and NOTE.**

CAUTION

- **Do not use emery cloth to polish the commutator. Particles of emery are conductive and may short-circuit the commutator bars. Do not use oil or lubricants on the commutator or brushes.**

NOTE: Oil on the commutator may indicate a faulty transaxle input shaft oil seal.

Armature Ground Test

CAUTION

- **Do not submerge the armature in solvent.**

NOTE: Before testing the armature, wipe it clean with a clean cloth. Remove any carbon dust and metal particles from between the commutator bars.

1. With a multimeter set to 200 ohms, place one probe on the commutator and the other on the armature core. The multimeter should indicate no continuity (**Figure 26-6, Page 26-6**). If the reading is incorrect, replace the armature.

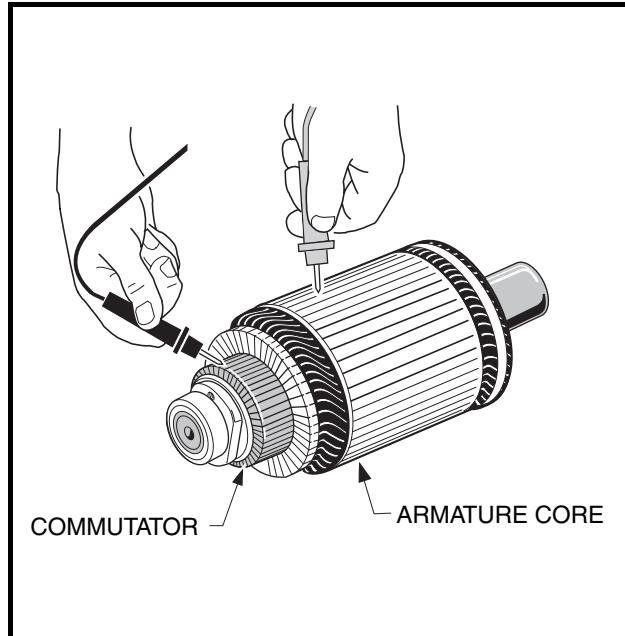

Figure 26-6 Armature Test

FIELD WINDINGS INSPECTION

Burned or scorched insulation on the field windings indicates the motor has overheated due to overloads or grounded or shorted coil windings. If the insulation on the field windings is scorched, replace the motor or the stator shell assembly.

MOTOR COMPONENTS

1. Inspect the insulators (4 and 7) for cracks or other damage (**Figure 26-9, Page 26-8**).
2. Inspect the brushes (13) for damage or excessive wear. Replace brushes if required. **See following NOTE.**
3. Inspect the brush springs (14) (**Figure 26-9, Page 26-8**). Replace springs that are discolored from heat (light gold or blue tinted). Replace springs which apply a force of less than 16 oz. (**Figure 26-7, Page 26-7**). **See following CAUTION and NOTE.**

CAUTION

- **When checking brush spring tension, do not over-extend the spring. Using excessive force will damage the spring.**

NOTE: *When installing new brushes, remove and replace brushes one at a time. This method ensures the terminals and brushes will be properly positioned in the rigging. Refer to Motor Assembly for brush installation. See Motor Assembly on page 26-10.*

When replacing brushes, replace all four brushes. Never replace only two.

Install the brushes in the same rigging 180° apart from each other.

BEARING INSPECTION

1. Use a clean cloth to wipe the carbon dust off of the bearing. Inspect the bearing by spinning it by hand and checking for both axial (A) and radial (B) play (**Figure 26-8, Page 26-7**).
2. Replace the bearing if it is noisy, does not spin smoothly, or has excessive play. Check the bearing and replace if rusted, worn, cracked, or if there is an abnormal color change in the metal of the bearing. Do not remove the bearing from the armature shaft unless it is to be replaced.

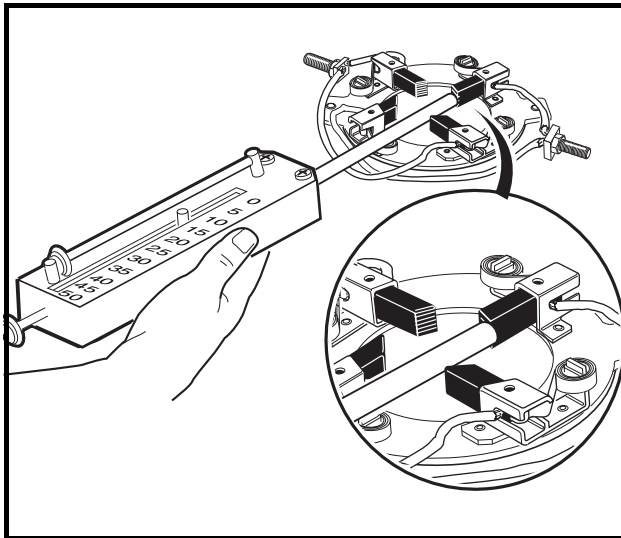

Figure 26-7 Brush Spring Tension Test

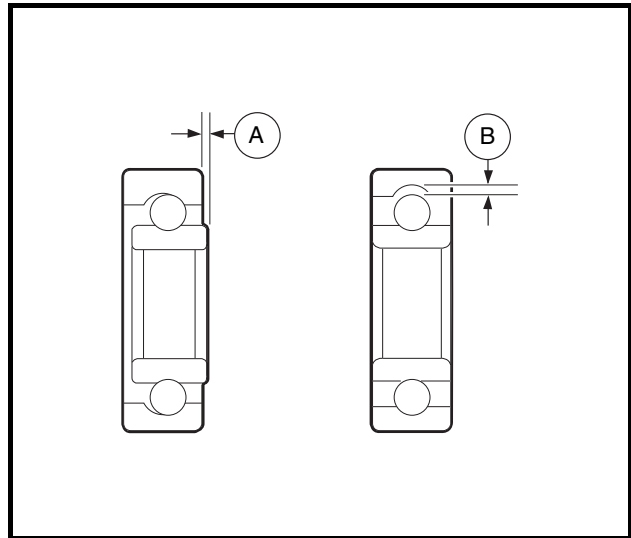

Figure 26-8 Inspect Bearing

BEARING REMOVAL

1. Place the wedge attachment tool (CCI P/N 1012812) between the bearing (15) and the armature (17) (**Figure 26-9, Page 26-8**). Make sure the wedge attachment tool is supporting the inner race of the bearing. If a press is not available, secure a bearing puller (CCI P/N 1012811) to the bearing and pull the bearing off of the end of the armature shaft. Support the shaft so it will not drop when the bearing is removed (**Figure 26-10, Page 26-10**). Discard the bearing and speed sensor magnet. **See following NOTE.**

NOTE: The speed sensor magnet will be pressed off by the bearing when the bearing is removed.

BEARING INSTALLATION

1. Press a new bearing (15) onto the armature (**Figure 26-9, Page 26-8**). Use an arbor press that exerts pressure on the inner race only. **See following NOTE.**

NOTE: Make sure the bearing retainer (16) is positioned on the armature shaft before the bearing is pressed onto the armature (**Figure 26-9, Page 26-8**).

An arbor with an outside diameter of less than 5/8 inch (16 mm) should be used to press the bearing onto the armature.

2. Install the speed sensor magnet. **See Speed Sensor Magnet Installation on page 26-9.**

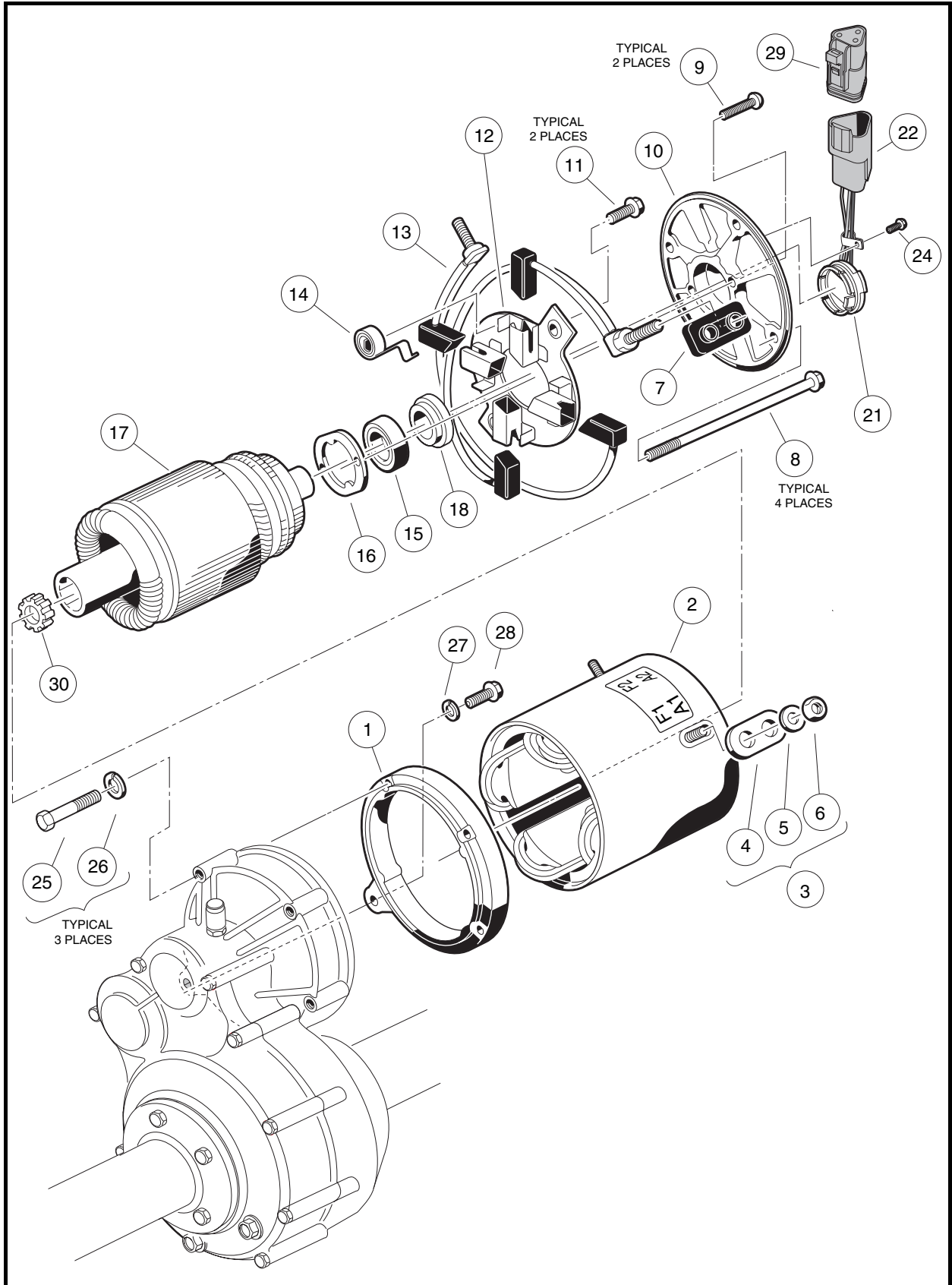

Figure 26-9 Motor – Model 5BC59JBS6390

SPEED SENSOR MAGNET INSPECTION

Inspect the speed sensor magnet (18) for rust, wear, and cracks (**Figure 26-9, Page 26-8**). Replace the magnet if necessary.

SPEED SENSOR MAGNET REMOVAL

1. To remove the speed sensor magnet (18), remove the motor bearing (**Figure 26-9, Page 26-8**). See **Bearing Removal on page 26-7**.

SPEED SENSOR MAGNET INSTALLATION

1. Using a solid bearing driver with a diameter of no less than 1 inch (2.54 cm), press the motor speed sensor magnet (18) onto the shaft until the magnet hub is flush with the armature shaft.

RECONDITIONING THE MOTOR

See **General Warning on page 1-1**.

Motor reconditioning must be performed by a qualified motor repair technician. The use of proper tools and procedures is absolutely essential for successful motor reconditioning.

Motor Specifications

Any rework must be performed by a qualified technician. Motor service specifications are listed in the following table.

ITEM	SERVICE LIMIT
Commutator diameter (minimum)	2.265 in. (66.675 mm)
Commutator concentric with armature shaft within	0.001 in. (0.0254 mm)
Limit depth of cut when machining commutator	0.005 in. (0.127 mm)
Bar to bar runout should not exceed	0.002 in. (0.00508 mm)
If undercut of segment insulator is less than 0.016 inch (0.406 mm), it should be undercut to	0.031 in. (0.8 mm)
Machined face of commutator	8-16 microinches (203.2-406.4 nm)
Field coil resistance (shunt-wound, 3.20 hp)	1.61 ohms

MOTOR ASSEMBLY

See General Warning on page 1-1.

1. If the bearing has been removed, replace the bearing. See **Bearing Installation** on page 26-7.
2. Install the brushes. See following **NOTE**.

NOTE: When installing new brushes, remove and replace brushes one at a time. This method ensures the terminals and brushes will be properly positioned in the rigging.

When replacing brushes, replace all four brushes. Never replace only two.

Install the brushes in the same rigging 180° apart from each other.

- 2.1. With brush rigging facing down and held slightly above stator shell, insert the two terminal posts through insulators in stator shell wall at the A1 and A2 positions. Insert brush holder screws through the holes in the brush rigging and into the threaded holes in the mounting bracket (**Figure 26-11, Page 26-11**). Tighten the screws to 20 in-lb (2.3 N·m).
- 2.2. One at a time, push brush spring extensions back from brushes and slide the brushes back until they are completely retracted into their mounting slots. Then position the brush springs against the sides of the brushes so that spring pressure will hold them in the retracted position (**Figure 26-5, Page 26-4**).

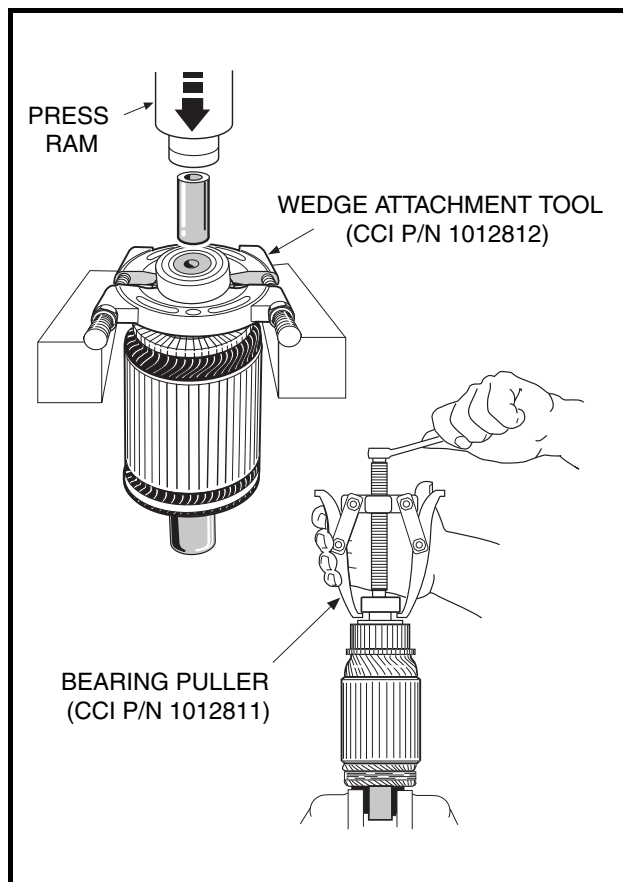

Figure 26-10 Bearing Removal

- 2.3. Slide the armature, bearing end first, into the stator shell. Make sure the brushes are held back while positioning the armature for proper commutator/brush contact. Release the brushes and place the springs outside the brushes so the brushes are being held against the commutator. **See following CAUTION.**

CAUTION

- If the motor is being assembled with the armature standing on end as the commutator is positioned, make sure the brushes are held back. Do not allow the brushes to support the weight of the stator shell. The brushes can be easily damaged by this weight.

3. Install the end shield onto the stator shell.

- 3.1. Attach the end shield (10) to bearing retainer (16) by aligning the two holes in the bearing retainer with the two mating holes in the end shield and installing the screws (9) (**Figure 26-9, Page 26-8**). Tighten the screws to 17 in-lb (1.9 N·m). **See following NOTE.**

NOTE: Use a long screw with the same thread specifications as the mounting screws to maintain hole alignment while starting the first mounting screw (**Figure 26-12, Page 26-11**).

- 3.2. Align the match marks on the end shield and the stator shell, then install the four screws (8) (**Figure 26-9, Page 26-8**). Tighten the screws to 90 in-lb (10 N·m). **See following NOTE.**

NOTE: Make sure the motor speed sensor wires located on the end shield are aligned between the terminals on the motor housing.

4. Make sure the armature turns freely. If it does not turn freely, disassemble the motor to find the problem. Make sure the bearing is properly seated in the end shield when assembling the motor.

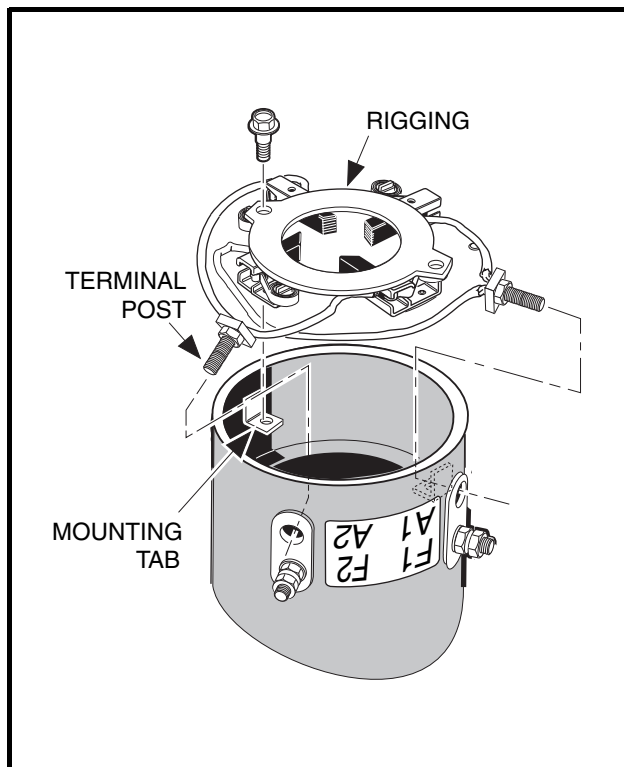

Figure 26-11 Brush Installation

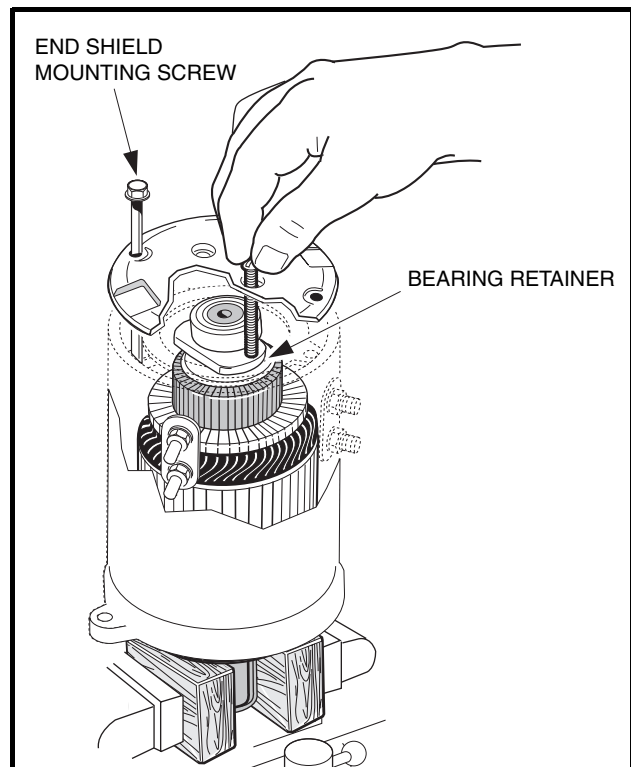

Figure 26-12 End Shield Installation

MOTOR INSTALLATION

See General Warning on page 1-1.

1. Clean the transaxle input shaft.
 - 1.1. Spray the input shaft thoroughly with CRC® Brakleen™ or equivalent brake cleaner degreaser.
 - 1.2. Wipe input shaft with a clean cloth.
 - 1.3. Inspect the grooves of the input shaft and remove any remaining debris.
 - 1.4. Repeat steps 1.1 through 1.3 until input shaft is clean.
2. Lubricate the transaxle input shaft.
 - 2.1. Squeeze approximately 1/2 inch (1.3 cm) of moly-teflon lubricant (CCI P/N 102243403) from tube onto a putty knife as shown (**Figure 26-13, Page 26-12**).
 - 2.2. Rotate wheels to rotate input shaft.
 - 2.3. Apply motor coupling grease evenly to the rotating input shaft starting at approximately 1/8 inch (3.1 mm) from the end of the shaft and working back toward the transaxle (away from the end of the shaft) (**Figure 26-14, Page 26-12**).
 - 2.4. The grease should be evenly distributed in the grooves to a width of approximately 3/8 inch (9.5 mm).
 - 2.5. Use a flat screwdriver to clean the grease out of one of the grooves and allow air to escape when the motor is pushed onto the input shaft.

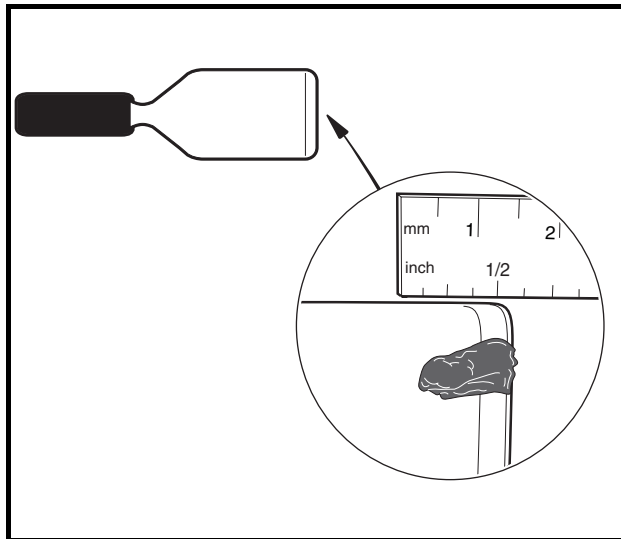

Figure 26-13 Grease on Putty Knife

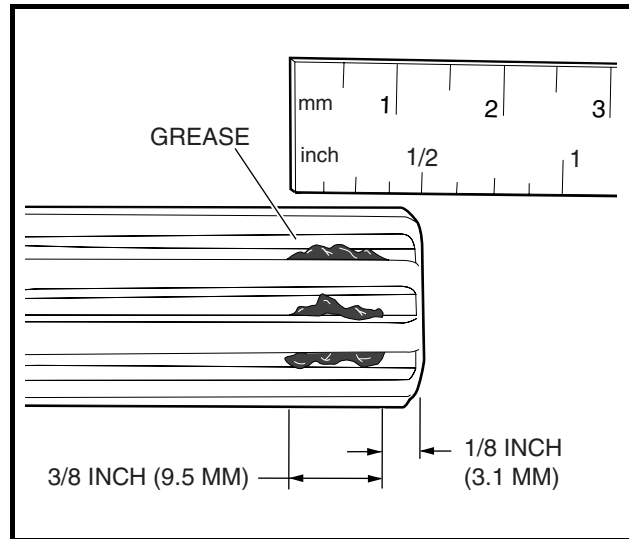

Figure 26-14 Application of grease to Input Shaft Grooves

- 2.6. Check the chamfer and end of the input shaft to ensure these areas are completely clean of grease as shown (**Figure 26-15, Page 26-13**).
3. Install the molded bumper.
 - 3.1. With the flat side toward the bottom of the coupling, install the molded bumper (30) into the motor coupling (**Figure 26-9, Page 26-8**). See following **NOTE**.

NOTE: The motor coupling and the new molded bumper must be free of grease and debris.

- 3.2. Ensure that the installed bumper is seated at the bottom of the coupling.

4. Install motor on transaxle.

- 4.1. Slide the motor coupling onto the transaxle input shaft.
- See following NOTE.**

NOTE: The coupling will push any excess grease on the input shaft along the shaft toward the transaxle.

When the motor is pushed onto the input shaft, the motor adapter ring (1) will not bottom out against the transaxle housing (**Figure 26-9, Page 26-8**). There will be approximately 1/16 inch (1.6 mm) gap between the motor adapter ring and transaxle housing as shown (**Figure 26-16, Page 26-13**).

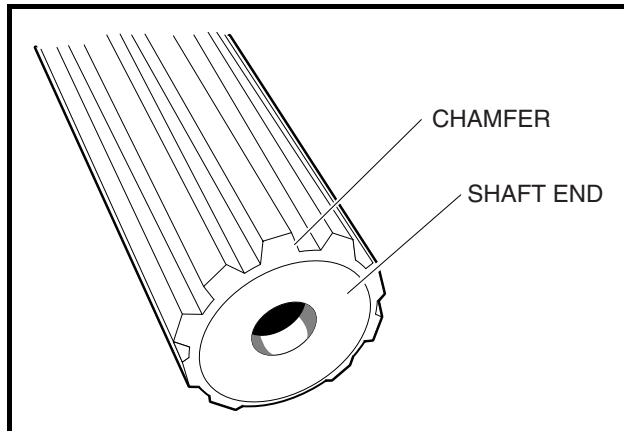

Figure 26-15 Clean Chamfer and Input Shaft End

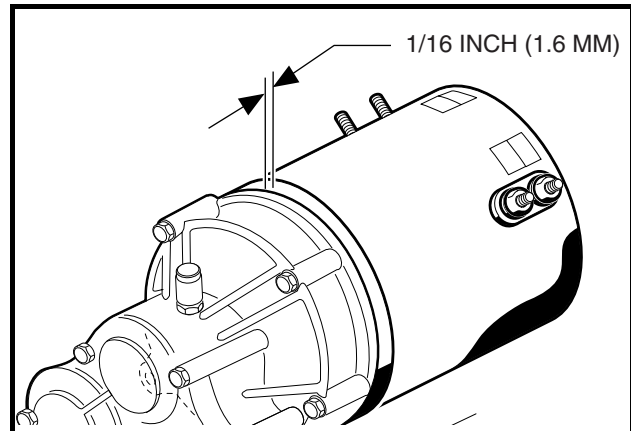

Figure 26-16 Gap at Motor and Transaxle

- 4.2. Loosely install four motor bolts and washers that secure the motor to the transaxle. Do not tighten.
- 4.3. Begin finger-tightening the bolts in the sequence indicated (**Figure 26-18, Page 26-14**). Continue tightening by hand until the motor is seated in the transaxle housing. **See following CAUTION and NOTE.**

CAUTION

- Make sure the motor is properly seated in the transaxle housing.

NOTE: Failure to install and tighten the motor mounting bolts in the proper sequence and to the proper tightness may result in motor noise during operation.

- 4.4. Tighten the right bolt (1) to 65 in-lb (7.3 N·m).
- 4.5. Tighten the left bolt (2) to 65 in-lb (7.3 N·m).
- 4.6. Tighten the center bolt (3) to 65 in-lb (7.3 N·m) (**Figure 26-18, Page 26-14**).
- 4.7. Tighten the bolt (4) inserted through the tab to 155 in-lb (17.5 N·m) (**Figure 26-17, Page 26-14**).
- 4.8. Install the motor wires, making sure they are connected to the correct motor terminals and that the terminal orientation is correct. **See Wiring Diagram on page 21-2.** Tighten the terminal retaining nuts to 65 in-lb (7.3 N·m).
- 4.9. Secure the white, orange, green, and blue wires with a wire tie so that none of the motor wires will scrub the motor or transaxle when the vehicle is in operation.
- 4.10. Connect the three-pin speed sensor wire to the vehicle wire harness.
5. If using a chain hoist, lower the vehicle and guide the leaf springs into the shackles. If using a floor jack, raise the transaxle until the leaf springs can be guided into the shackles.

6. Insert the mounting bolts through the spring shackles and the bushings in the leaf spring eyes and install locknuts. Tighten the bolts to 23 ft-lb (31 N·m). **See Leaf Spring Installation – All Vehicles, Section 9, Page 9-4.**
7. Install the shock absorbers. Tighten nut until rubber bushing expands to the diameter of the cup washer.
8. If removed, install wheels and finger tighten the lug nuts.
9. Lift vehicle and remove jack stands. Lower vehicle to the floor and tighten lug nuts, using a crisscross pattern, to 55 ft-lb (74.6 N·m).
10. Place the Tow/Run switch in the TOW position and connect the batteries, positive (+) cable first. Tighten battery terminals to 110 in-lb (12.4 N·m) and coat terminals with Battery Terminal Protector Spray (CCI P/N 1014305) to minimize corrosion.
11. Place the Tow/Run switch in the RUN position.
12. Inspect the vehicle for proper operation. **See following WARNING.**

⚠ WARNING

- **Make sure that the vehicle operates in the forward direction when the Forward/Reverse switch is in the FORWARD position.**
- **Make sure that the vehicle operates in the reverse direction when the Forward/Reverse switch is in the REVERSE position. The reverse buzzer will sound as a warning when the Forward/Reverse switch is in REVERSE.**
- **Make sure that the vehicle does not operate when the Forward/Reverse switch is in the NEUTRAL position.**

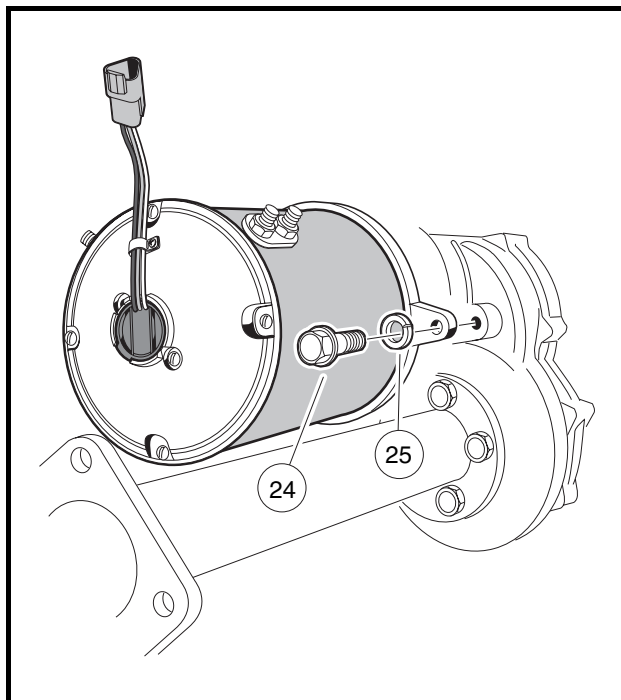

Figure 26-17 Motor Installation

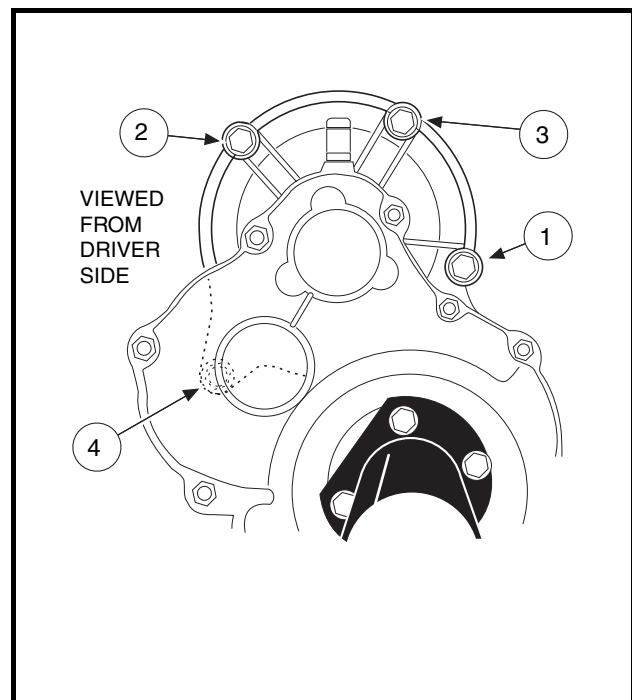

Figure 26-18 Motor Mount

MOTOR SPEED SENSOR

See General Warning on page 1-1.

Testing the Motor Speed Sensor

See Test Procedure 13, Section 21, Page 21-29.

Motor Speed Sensor Removal

1. Disconnect the battery cables as instructed. See **WARNING “To avoid unintentionally starting...”** in General Warning on page 1-2.
2. Disconnect the three-pin connector (22) from the vehicle wire harness (**Figure 26-19, Page 26-15**).
3. Using a screwdriver, gently pry the motor speed sensor (21) from recessed area on the motor end shield.

Motor Speed Sensor Installation

1. Position the motor speed sensor (21) as shown and firmly press the speed sensor into the motor end shield. Sensor should fit flush against the motor (**Figure 26-19, Page 26-15**).
2. Connect the three-pin connector (22) to the vehicle wire harness.
3. Place the Tow/Run switch in the TOW position and connect the batteries, positive (+) cable first. Tighten battery terminals to 110 in-lb (12.4 N·m) and coat terminals with Battery Terminal Protector Spray (CCI P/N 1014305) to minimize corrosion.

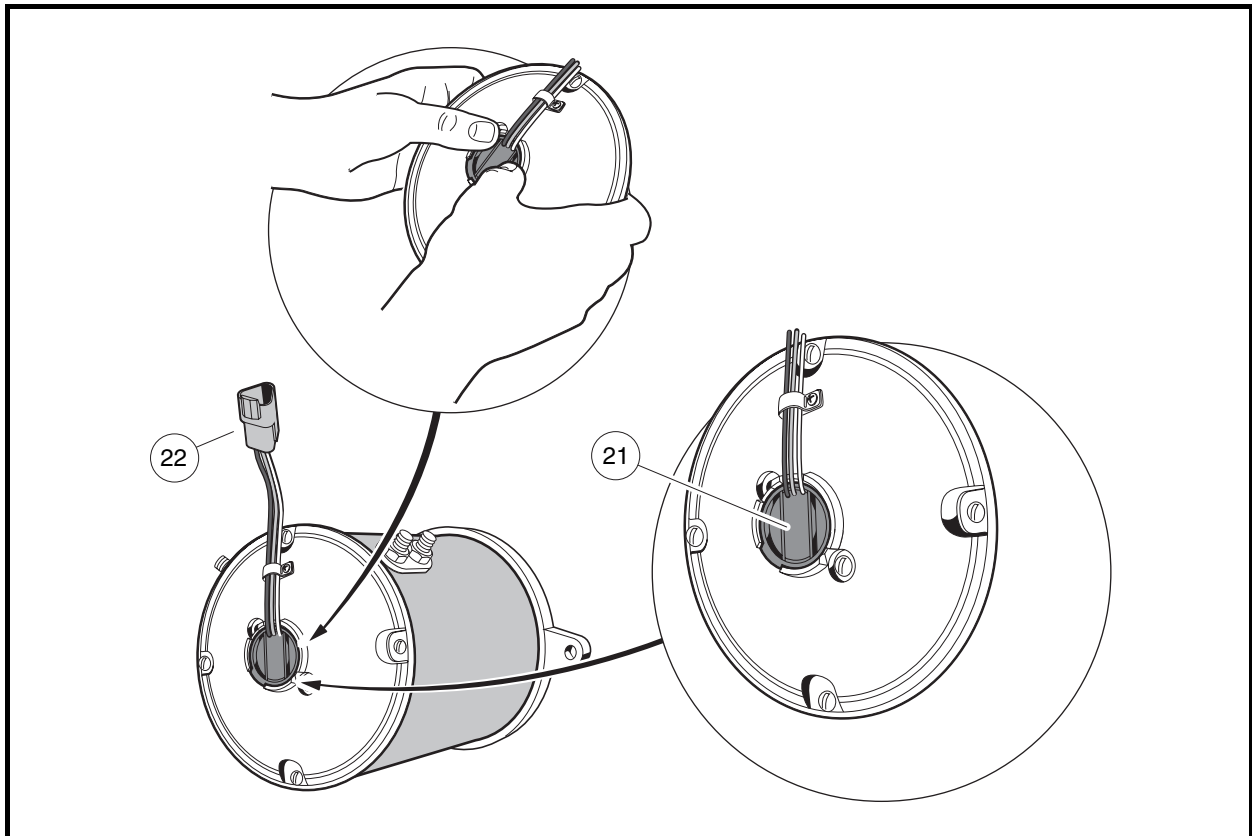

Figure 26-19 Motor Speed Sensor

SECTION 27 – MOTOR (MODEL EJ4-4001)

⚠ DANGER

- See General Warning on page 1-1.

⚠ WARNING

- See General Warning on page 1-1.

GENERAL INFORMATION

The electric vehicle is equipped with a 48-volt DC, shunt-wound, reversible traction motor. The shunt-wound motor is designed for use on electric vehicles only. It is recommended that motors requiring major repair be sent to a qualified motor repair shop; however, there are many relatively simple tasks that can be performed by a technician with general knowledge and experience in electric motor repair.

MOTOR IDENTIFICATION

There are two types of motors used in the electric vehicle: Model 5BC59JBS6390 (gray housing), and EJ4-4001 (black housing). Do not attempt to service a motor that has not been properly identified. If the motor cannot be properly identified, contact your local dealer or distributor.

EXTERNAL MOTOR TESTING

The following tests can be performed without disassembling the motor using a multimeter or continuity tester.

NOTE: Tag the motor wires for identification before disconnecting.

TEST PROCEDURE 1 – INTERNAL SHORT CIRCUITS

See General Warning on page 1-1.

1. Disconnect the battery cables as instructed. See **WARNING “To avoid unintentionally starting...”** in **General Warning on page 1-2.**
2. Disconnect wires from terminals on motor using two wrenches to prevent posts from turning.
3. With a multimeter set to 200 ohms, place black (–) probe on motor housing. Scratch through paint to ensure a good connection. Place red (+) probe on A1, A2, S1, and S2 terminals respectively. Multimeter should indicate no continuity. If readings are incorrect, motor will need to be removed from the vehicle and repaired by a qualified technician. See **Motor Removal on page 27-2.**
 - 3.1. An incorrect reading from the A1 or A2 terminal indicates three possible problems: a grounded A1 or A2 terminal, a grounded wire in the brush area, or a grounded armature/commutator. An incorrect reading for the S1 or S2 terminal indicates a possible grounded S1 or S2 terminal or field coil.

TEST PROCEDURE 2 – ARMATURE CIRCUIT OPEN

See General Warning on page 1-1.

1. Disconnect the battery cables as instructed. See **WARNING “To avoid unintentionally starting...”** in **General Warning on page 1-2.**
2. Disconnect wires from the A1 and A2 terminals on the motor using two wrenches to prevent posts from turning. Set a multimeter to 200 ohms and place the red (+) probe on the A1 terminal and black (–) probe on the A2 terminal. The multimeter should indicate continuity. If the reading is incorrect, a possible open or poor contact in a brush assembly and/or open armature windings may be the cause. The motor will need to be removed from the vehicle and repaired by a qualified technician. See **Motor Removal on page 27-2.**

TEST PROCEDURE 3 – FIELD CIRCUIT OPEN

See General Warning on page 1-1.

1. Disconnect the battery cables as instructed. See **WARNING “To avoid unintentionally starting...”** in **General Warning on page 1-2.**
2. Disconnect wires from the S1 and S2 terminals on the motor using two wrenches to prevent posts from turning. Set a multimeter to 200 ohms and place the red (+) probe on the S1 terminal and the black (–) probe on the S2 terminal. The multimeter should indicate continuity. If the reading is incorrect, a possible open field coil or bad connections at the terminals may be the cause. The motor will need to be removed from the vehicle and repaired by a qualified technician. See **Motor Removal on page 27-2.**

MOTOR

See General Warning on page 1-1.

MOTOR REMOVAL

1. Disconnect the battery cables as instructed. See **WARNING “To avoid unintentionally starting...”** in **General Warning on page 1-2.**
2. Disconnect wires from the terminals on the motor using two wrenches to prevent posts from turning. Label the wires to ensure proper reconnection.
3. Slightly loosen all the lug nuts on both rear wheels.
4. Place floor jack under transaxle and raise rear of vehicle (**Figure 27-1, Page 27-3**) then place jack stands under frame crossmember between the spring mount and the side stringer, just forward of each rear wheel. Lower the vehicle to let the jack stands support the vehicle (**Figure 27-2, Page 27-3**). See following **WARNING**.

⚠ WARNING

- Lift only one end of the vehicle at a time. Use a suitable lifting device (chain hoist or hydraulic floor jack) with 1000 lb. (454 kg) minimum lifting capacity. Do not use lifting device to hold vehicle in raised position. Use approved jack stands of proper weight capacity to support the vehicle and chock the wheels that remain on the floor. When not performing a test or service procedure that requires movement of the wheels, lock the brakes.

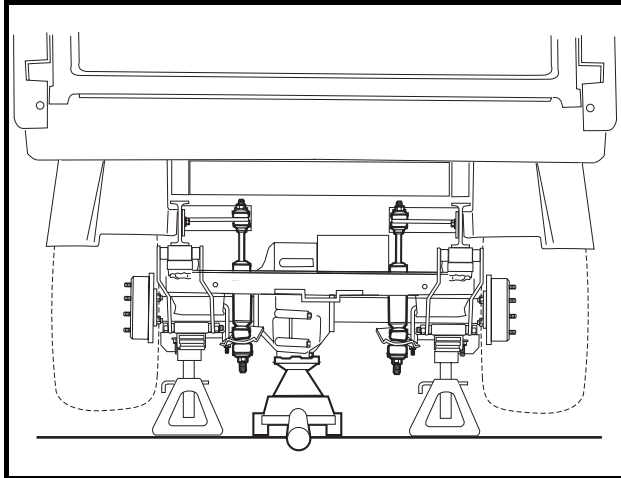

Figure 27-1 Lift Vehicle with Floor Jack

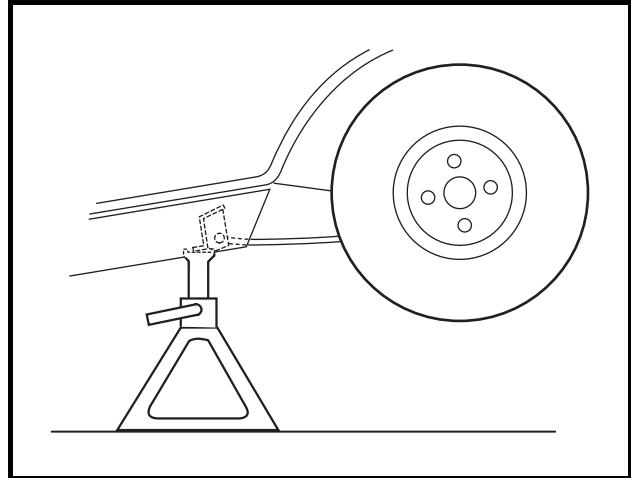

Figure 27-2 Vehicle Supported on Jack Stands

5. Remove both rear wheels.
6. Remove the nut, cup washer, and bushing from the bottom side of the shock absorber. Compress the shock absorber (pushing upwards) to move it out of the way (**Figure 27-3, Page 27-3**).
7. Remove the nuts and bolts mounting the rear leaf springs to the shackles.
8. To gain easier access to the motor, lower the transaxle as low as it will go. If more room is needed, remove the jack from beneath the transaxle and allow the springs to rest on the floor (**Figure 27-3, Page 27-3**).

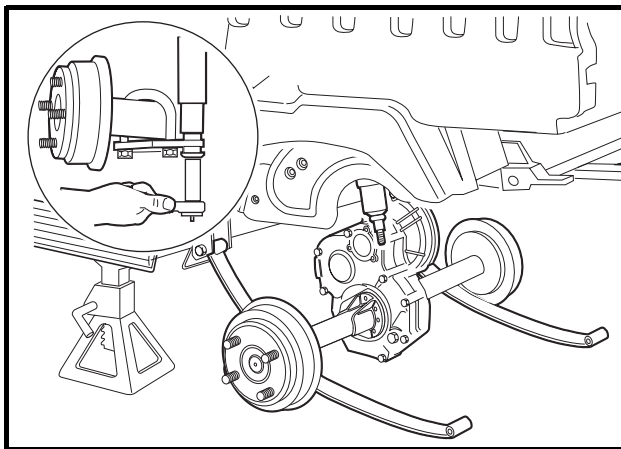

Figure 27-3 Lower Axle

9. Remove the four bolts that mount the motor to the transaxle (**Figure 27-24, Page 27-15**). See following **CAUTION**.

⚠ CAUTION

- **Do not position fingers under motor when sliding motor off of the input shaft in step 9. Fingers may get pinched when motor disengages.**
10. Carefully slide the motor away from the transaxle until the motor spline disengages the input shaft and remove the motor from the vehicle.



Figure 27-4 Speed Sensor Magnet



Figure 27-5 End Cap

MOTOR DISASSEMBLY

1. Before beginning disassembly, place match marks on the motor end cap and motor frame.
2. Remove speed sensor and magnet.
 - 2.1. Remove the two screws (25) that secure the speed sensor (10) to the end cap (11) (**Figure 27-15, Page 27-10**).
 - 2.2. Remove the screw securing the magnet to the armature shaft (**Figure 27-4, Page 27-4**).
 - 2.3. Inspect the speed sensor magnet. **See Speed Sensor Magnet Inspection on page 27-9.**
3. Loosen, but do not remove, the two screws securing the end cap to the motor frame (**Figure 27-5, Page 27-4**).



Figure 27-6 End Cap Disengagement



Figure 27-7 End Cap Removal

4. Orient the motor so that the splined end of the armature is facing down.
5. Inspect the area where the end cap mates with the motor frame. If the end cap appears to be loose where it connects to the motor frame, proceed to step 6; otherwise, disengage the end cap from the motor frame using the following procedure:
 - 5.1. With the end cap bolts loose (about 1/4 inch between the end cap and the head of the bolt), place a socket on the head of the bolt. **See following CAUTION.**

CAUTION

- **Ensure that there is sufficient thread engagement of the end cap bolts before proceeding. Performing the procedure without having adequate thread engagement could damage the motor frame, end cap, or end cap bolts.**

- 5.2. Gently tap each bolt, alternating between blows, until the end cap and motor frame become disengaged (**Figure 27-6, Page 27-4**).
6. Remove the two end cap bolts.
7. Remove the end cap and armature from the motor frame (**Figure 27-7, Page 27-4**).
8. Inspect the brush springs for proper tension. **See Motor Brush, Spring, and Terminal Insulator Inspection on page 27-8.**
9. Remove the armature from the end cap bearing. **See following CAUTION and NOTE.**

⚠ CAUTION

- **Removing the armature from the end cap requires two people: one to operate the press, and another to hold the armature. Failure to heed this CAUTION could result in personal injury and/or damage to the armature resulting from an unsupported armature falling after it becomes disengaged from the end cap bearing.**

NOTE: *Replacement of the end cap bearing is recommended if the armature is removed.*

- 9.1. Place the end cap in a press with the armature facing down.
- 9.2. Place a bearing press tool with an outer diameter smaller than that of the armature shaft between the press ram and the armature shaft (**Figure 27-8, Page 27-6**).
- 9.3. Have an assistant support the armature while the press is activated.
10. Inspect the armature for wear and damage. **See Armature Inspection and Testing on page 27-6.**
11. Inspect the motor frame and field windings. **See Motor Frame and Field Windings Inspection on page 27-7.**
12. Remove the brush rigging.
 - 12.1. Mark the brush terminal posts (A1 and A2).
 - 12.2. Remove the two nuts securing the brush terminals (A1 and A2) to the end cap (**Figure 27-9, Page 27-6**).
 - 12.3. Remove the two screws and the brush rigging to the end cap (**Figure 27-10, Page 27-6**).
13. Inspect the terminal insulators. **See Terminal Insulator Inspection on page 27-9.**
14. Remove the bearing from the end cap.
 - 14.1. Remove the retaining ring that secures the bearing in the end cap (**Figure 27-11, Page 27-6**).
 - 14.2. Use an arbor press to remove the bearing from the end cap.
15. Inspect the bearing for wear and damage. **See Bearing Inspection on page 27-9.**



Figure 27-8 Armature Removal



Figure 27-9 A1 and A2 Terminals



Figure 27-10 Brush Rigging



Figure 27-11 Bearing Retaining Ring

MOTOR COMPONENT TESTING AND INSPECTION

See General Warning on page 1-1.

ARMATURE INSPECTION AND TESTING

1. Remove the motor from the vehicle. See **Motor Removal, Section 27, Page 27-2.**
2. Remove the end cap and armature by performing steps 1 through 7 of Motor Disassembly on page 27-4.

Visual Inspection

- Burned, charred or cracked insulation
- Improperly cured varnish
- Thrown solder
- Flared armature windings
- Damaged armature core laminations

- Worn, burned or glazed commutators
- Dirty or oily commutators
- Raised commutator bars
- Worn armature bearing or shaft

A dirty or oily commutator should be cleaned and wiped dry. Abnormalities identified during the inspection can help determine original cause of failure. Slight roughness of the commutator can be polished smooth with 400 grit or finer sandpaper. **See following CAUTION and NOTE.**

CAUTION

- **Do not use emery cloth to polish the commutator. Particles of emery are conductive and may short-circuit the commutator bars. Do not use oil or lubricants on the commutator or brushes.**

NOTE: Oil on the commutator may indicate a faulty transaxle input shaft oil seal.

Armature Ground Test

CAUTION

- **Do not submerge the armature in solvent.**

NOTE: Before testing the armature, wipe it clean with a clean cloth. Remove any carbon dust and metal particles from between the commutator bars.

1. With a multimeter set to 200 ohms, place one probe on the commutator and the other on the armature core. The multimeter should indicate no continuity (**Figure 27-12, Page 27-7**). If the reading is incorrect, replace the armature.

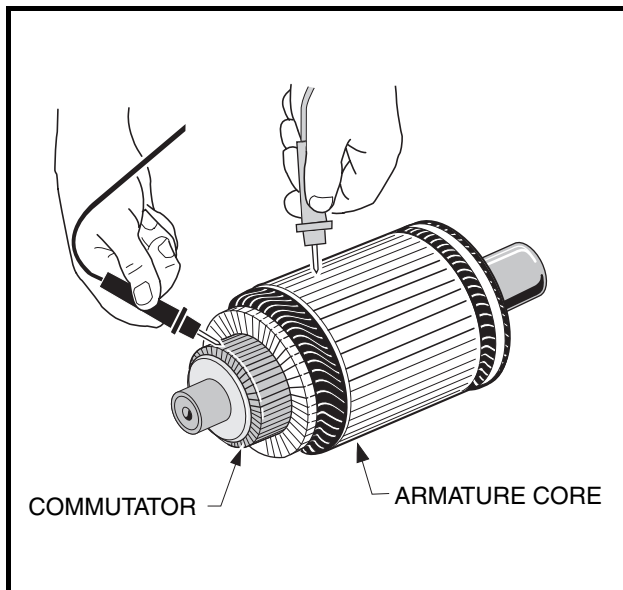

Figure 27-12 Armature Test

MOTOR FRAME AND FIELD WINDINGS INSPECTION

1. Remove the motor from the vehicle. **See Motor Removal, Section 27, Page 27-2.**

2. Remove the end cap and armature by performing steps 1 through 7 of Motor Disassembly on page 27-4.
3. Burned or scorched insulation on the field windings indicates the motor has overheated due to overloads or grounded or shorted coil windings. If the insulation on the field windings is scorched, replace the motor or the stator shell assembly.

MOTOR BRUSH, SPRING, AND TERMINAL INSULATOR INSPECTION

Brush Spring Tension Test

1. Remove the motor from the vehicle. **See Motor Removal, Section 27, Page 27-2.**
2. Remove the end cap and armature by performing steps 1 through 7 of Motor Disassembly on page 27-4.
3. Inspect the brush springs (14) (**Figure 27-15, Page 27-10**). Replace springs that are discolored from heat (light gold or blue tinted).
4. Test the brush springs for proper tension.
 - 4.1. Place a C-shaped steel plate on a scale.
 - 4.2. Place the end of the C-shaped plate so that it is between the spring and the brush as shown (**Figure 27-13, Page 27-9**).
 - 4.3. Gently pull the scale to obtain the spring tension reading. **See following CAUTION.**

CAUTION

- **When checking brush spring tension, do not over-extend the spring. Using excessive force will damage the spring.**

- 4.4. Replace springs which require a force of less than 35 oz. (990 grams) (**Figure 27-13, Page 27-9**). **See following NOTE.**

NOTE: When installing new brushes, remove and replace brushes one at a time. This method ensures the terminals and brushes will be properly positioned in the rigging. Refer to Motor Assembly for brush installation. **See Motor Assembly on page 27-11.**

When replacing brushes, replace all four brushes. Never replace only two.

Install the brushes in the same rigging 180° apart from each other.

Brush Inspection

1. Remove the motor from the vehicle. **See Motor Removal, Section 27, Page 27-2.**
2. Remove the end cap and armature by performing steps 1 through 7 of Motor Disassembly on page 27-4.
3. Inspect the brushes (13) for damage or excessive wear (**Figure 27-15, Page 27-10**). Replace brushes if required. **See preceding NOTE.**
4. Use dial calipers or a micrometer to measure the brush length. The minimum-allowable brush length is 0.62 inches (16 mm). Replace the set of brushes as required. **See preceding NOTE.**

Terminal Insulator Inspection

1. Remove the motor from the vehicle. **See Motor Removal, Section 27, Page 27-2.**
2. Remove the terminal insulators by performing steps 1 through 12 of Motor Disassembly on page 27-4.
1. Inspect the insulators (4 and 6) for cracks or other damage (**Figure 27-15, Page 27-10**). Replace insulators as required.

Bearing Inspection

NOTE: Replacement of the end cap bearing is highly-recommended if the end cap is removed from the motor. The following procedure is provided as a guideline for determining general bearing failure.

1. Remove the motor from the vehicle. **See Motor Removal, Section 27, Page 27-2.**
2. Remove the bearing by performing steps 1 through 14 of Motor Disassembly on page 27-4.
3. Use a clean cloth to wipe the carbon dust off of the bearing. Inspect the bearing by spinning it by hand and checking for both axial (A) and radial (B) play (**Figure 27-14, Page 27-9**).
4. Replace the bearing if it is noisy, does not spin smoothly, or has excessive play. Check the bearing and replace if rusted, worn, cracked, or if there is an abnormal color change in the metal of the bearing.

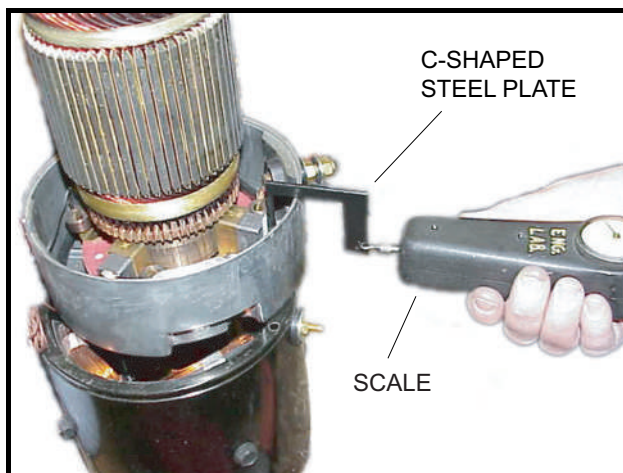

Figure 27-13 Brush Spring Tension Test

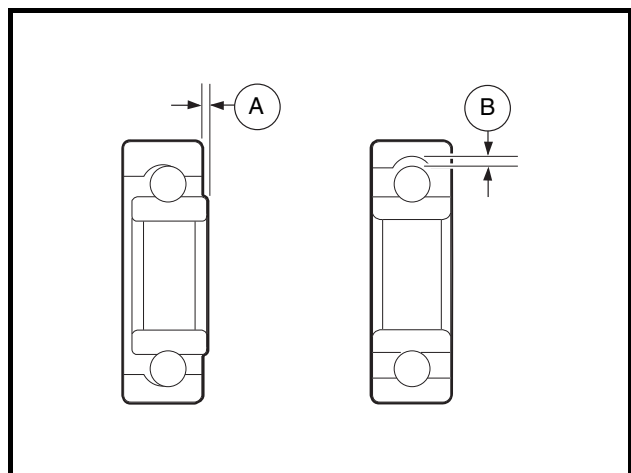

Figure 27-14 Bearing Inspection

Speed Sensor Magnet Inspection

Inspect the speed sensor magnet (24) for rust, wear, and cracks (**Figure 27-15, Page 27-10**). Replace the magnet if necessary.

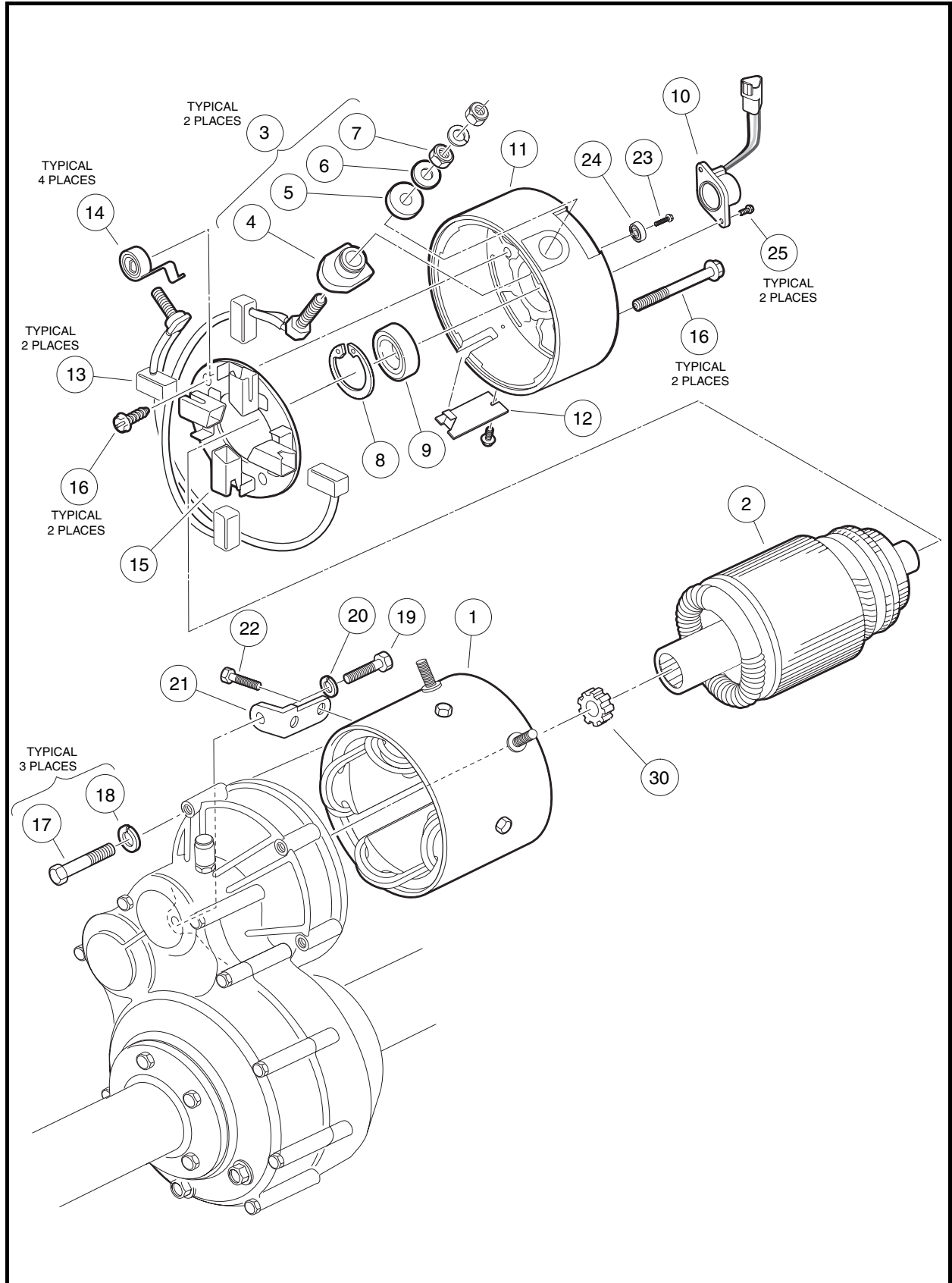

Figure 27-15 Motor – Model EJ4-4001

RECONDITIONING THE MOTOR

See General Warning on page 1-1.

Motor reconditioning must be performed by a qualified motor repair technician. The use of proper tools and procedures is absolutely essential for successful motor reconditioning.

Motor Specifications

Any rework must be performed by a qualified technician. Motor service specifications are listed in the following table.

ITEM	SERVICE LIMIT
Commutator diameter (minimum)	2.80 in. (71.10 mm)
Commutator concentric with armature shaft within	0.003 in. (0.08 mm)
Bar to bar runout should not exceed	0.005 in. (0.013 mm)
Undercut of segment insulator after machining commutator	0.040 in. (1.0 mm)
Armature resistance at 75 °F (24 °C)	0.012 ohms between bar 1 and bar 15
Field coil resistance at 75 °F (24 °C)	1.75 ohms

MOTOR ASSEMBLY

See General Warning on page 1-1.

1. Replace the bearing.
 - 1.1. Use an arbor press to install a new bearing into the end cap. To help avoid damaging the bearing, apply pressure only to the outer race when installing the bearing.
 - 1.2. Install the retaining ring to secure the bearing (**Figure 27-11, Page 27-6**).
2. Install the brushes and brush rigging. **See following NOTE.**

NOTE: When installing new brushes, remove and replace brushes one at a time. This method ensures the terminals and brushes will be properly positioned in the rigging.

When replacing brushes, replace all four brushes. Never replace only two.

Install the brushes in the same rigging 180° apart from each other.

- 2.1. Insert the brushes into the brush rigging as shown (**Figure 27-16, Page 27-12**).
- 2.2. Insert the two terminal posts through insulators (4) in the end cap (11) wall at the A1 and A2 positions (**Figure 27-15, Page 27-10**).
- 2.3. Place external insulators (5) and washers (6) on each terminal post, and secure terminal with nuts (7). Tighten nuts (7) to 100 in-lb (11.3 N·m). Ensure that the terminal posts do not rotate when tightening the nuts (**Figure 27-15, Page 27-10**).
- 2.4. Secure the brush rigging to the end cap with two screws. Tighten the screws to 25 in-lb (2.8 N·m) (**Figure 27-10, Page 27-6**).



Figure 27-16 Brush Rigging



Figure 27-17 Retracted Brushes

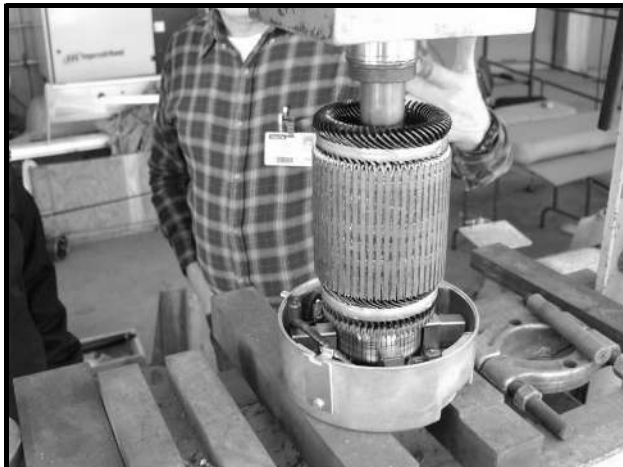

Figure 27-18 Armature Installation

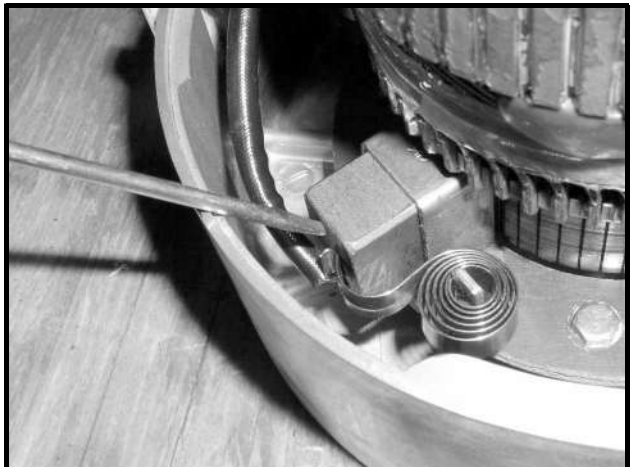

Figure 27-19 Brush Setting

- 2.5. One at a time, push the brushes back until they are completely retracted into their mounting slots and the spring pressure holds them in the retracted position as shown (**Figure 27-17, Page 27-12**).
3. With the brushes retracted, use an arbor press to press the armature shaft into the end cap bearing (**Figure 27-18, Page 27-12**). See following **CAUTION**.

CAUTION

- **Make sure the brushes are held back. Do not allow the brushes to support the weight of the commutator. The brushes can be easily damaged by this weight.**
4. Gently press each brush with a small screwdriver until the spring rests on the end of each brush as shown (**Figure 27-19, Page 27-12**).
 5. Align the match marks on the end cap and the motor frame (1) and secure with two bolts (16) (**Figure 27-15, Page 27-10**). Tighten bolts to 130 in-lb (14.7 N·m).
 6. Install the speed sensor magnet (24) with screw (23). Tighten to 65 in-lb (7.3 N·m).
 7. Install the speed sensor (10) with screws (25). Tighten to 25 in-lb (2.8 N·m).
 8. Make sure the armature turns freely. If it does not turn freely, disassemble the motor to find the problem.

MOTOR INSTALLATION

See General Warning on page 1-1.

1. Clean the transaxle input shaft.
 - 1.1. Spray the input shaft thoroughly with CRC® Brakleen™ or equivalent brake cleaner degreaser.
 - 1.2. Wipe input shaft with a clean cloth.
 - 1.3. Inspect the grooves of the input shaft and remove any remaining debris.
 - 1.4. Repeat steps 1.1 through 1.3 until input shaft is clean.
2. Lubricate the transaxle input shaft.
 - 2.1. Squeeze approximately 1/2 inch (1.3 cm) of moly-teflon lubricant (CCI P/N 102243403) from tube onto a putty knife as shown (**Figure 27-20, Page 27-13**).
 - 2.2. Rotate wheels to rotate input shaft.
 - 2.3. Apply motor coupling grease evenly to the rotating input shaft starting at approximately 1/8 inch (3.1 mm) from the end of the shaft and working back toward the transaxle (away from the end of the shaft) (**Figure 27-21, Page 27-13**).
 - 2.4. The grease should be evenly distributed in the grooves to a width of approximately 3/8 inch (9.5 mm).
 - 2.5. Use a flat screwdriver to clean the grease out of one of the grooves and allow air to escape when the motor is pushed onto the input shaft.

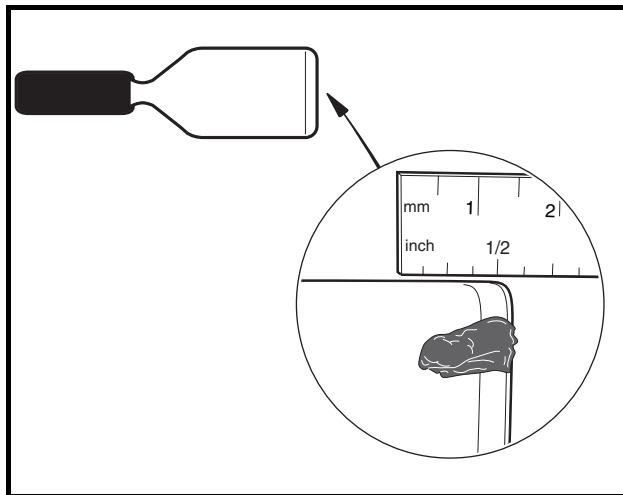

Figure 27-20 Grease on Putty Knife

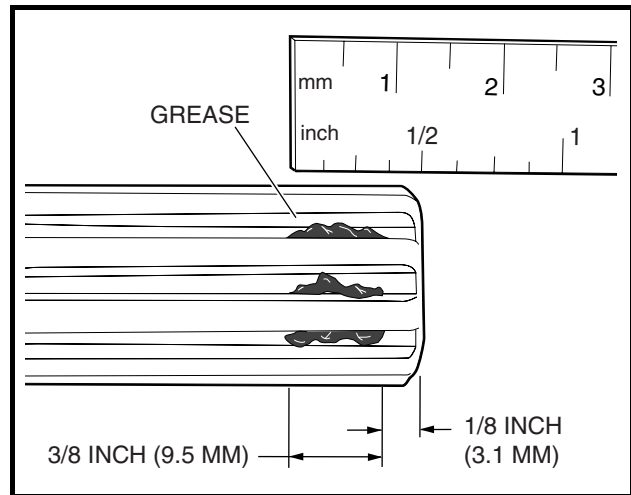

Figure 27-21 Application of grease to Input Shaft Grooves

- 2.6. Check the chamfer and end of the input shaft to ensure these areas are completely clean of grease as shown (**Figure 27-22, Page 27-14**).
3. Install the molded bumper.
 - 3.1. With the flat side toward the bottom of the coupling, install the molded bumper (30) into the motor coupling (**Figure 27-15, Page 27-10**). **See following NOTE.**

NOTE: The motor coupling and the new molded bumper must be free of grease and debris.

- 3.2. Ensure that the installed bumper is seated at the bottom of the coupling.

4. Install motor on transaxle.
 - 4.1. Slide the motor coupling onto the transaxle input shaft. **See following NOTE.**

NOTE: The coupling will push any excess grease on the input shaft along the shaft toward the transaxle.

When the motor is pushed onto the input shaft, the motor housing will not bottom out against the transaxle housing (**Figure 27-15, Page 27-10**). There will be approximately 1/16 inch (1.6 mm) gap between the motor adapter ring and transaxle housing as shown (**Figure 27-23, Page 27-14**).

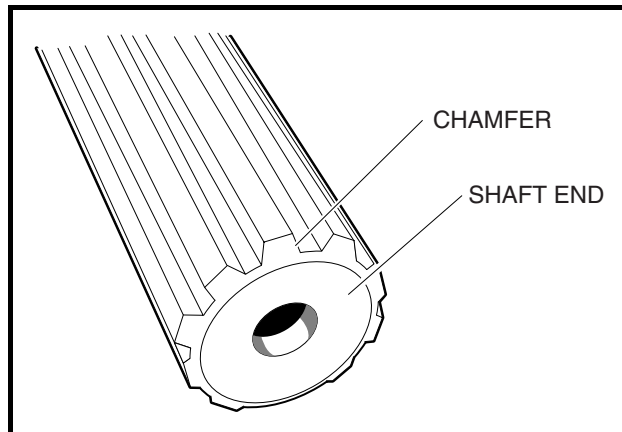

Figure 27-22 Clean Chamfer and Input Shaft End

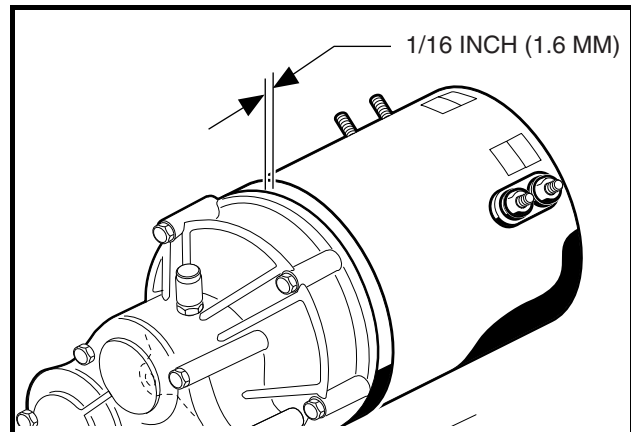

Figure 27-23 Gap at Motor and Transaxle

- 4.2. Loosely install the four bolts that secure the motor to the transaxle. Do not tighten.
- 4.3. Begin finger-tightening the bolts in the sequence indicated (**Figure 27-24, Page 27-15**). Continue tightening by hand until the motor is seated in the transaxle housing. **See following CAUTION and NOTE.**

CAUTION

- Make sure the motor is properly seated in the transaxle housing.

NOTE: Failure to install and tighten the motor mounting bolts in the proper sequence and to the proper tightness may result in motor noise during operation.

- 4.4. Tighten the right bolt (1) to 65 in-lb (7.3 N·m).
 - 4.5. Tighten the left bolt (2) to 65 in-lb (7.3 N·m).
 - 4.6. Tighten the center bolt (3) to 65 in-lb (7.3 N·m) (**Figure 27-24, Page 27-15**).
 - 4.7. Tighten the bolt (4) inserted through the tab to 155 in-lb (17.5 N·m) (**Figure 27-24, Page 27-15**).
 - 4.8. Install the motor wires, making sure they are connected to the correct motor terminals and that the terminal orientation is correct. **See Wiring Diagram on page 21-2.** Tighten the terminal retaining nuts to 65 in-lb (7.3 N·m).
 - 4.9. Secure the white, orange, green, and blue wires with a wire tie so that none of the motor wires will scrub the motor or transaxle when the vehicle is in operation.
 - 4.10. Connect the three-pin speed sensor wire to the vehicle wire harness.
5. If using a chain hoist, lower the vehicle and guide the leaf springs into the shackles. If using a floor jack, raise the transaxle until the leaf springs can be guided into the shackles.

6. Insert the mounting bolts through the spring shackles and the bushings in the leaf spring eyes and install locknuts. Tighten the bolts to 23 ft-lb (31 N·m). **See Leaf Spring Installation – All Vehicles, Section 9, Page 9-4.**
7. Install the shock absorbers. Tighten nut until rubber bushing expands to the diameter of the cup washer.
8. If removed, install wheels and finger tighten the lug nuts.
9. Lift vehicle and remove jack stands. Lower vehicle to the floor and tighten lug nuts, using a crisscross pattern, to 55 ft-lb (74.6 N·m).
10. Place the Tow/Run switch in the TOW position and connect the batteries, positive (+) cable first. Tighten battery terminals to 110 in-lb (12.4 N·m) and coat terminals with Battery Terminal Protector Spray (CCI P/N 1014305) to minimize corrosion.
11. Place the Tow/Run switch in the RUN position.
12. Inspect the vehicle for proper operation. **See following WARNING.**

⚠ WARNING

- **Make sure that the vehicle operates in the forward direction when the Forward/Reverse switch is in the FORWARD position.**
- **Make sure that the vehicle operates in the reverse direction when the Forward/Reverse switch is in the REVERSE position. The reverse buzzer will sound as a warning when the Forward/Reverse switch is in REVERSE.**
- **Make sure that the vehicle does not operate when the Forward/Reverse switch is in the NEUTRAL position.**

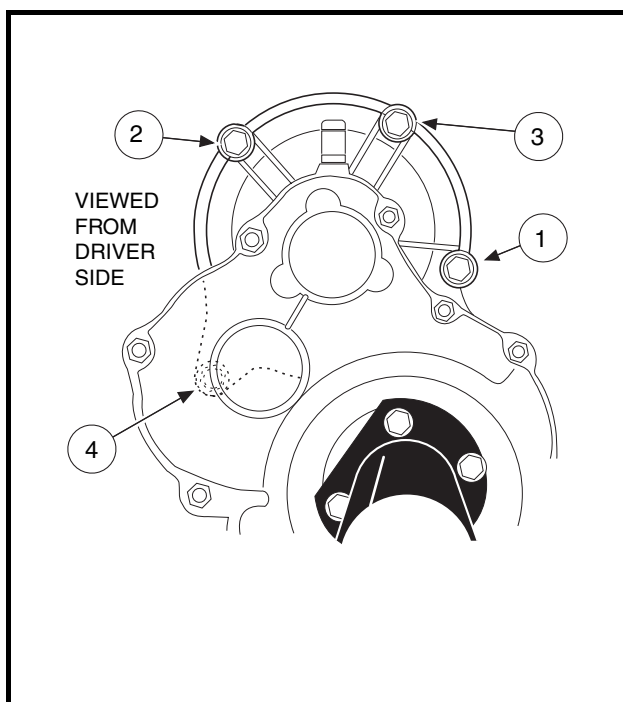

Figure 27-24 Motor Mount

SECTION 28 – TRANSAXLE (TYPE G): ELECTRIC VEHICLE

⚠ DANGER

- See General Warning on page 1-1.

⚠ WARNING

- See General Warning on page 1-1.

TRANSAXLE IDENTIFICATION

This electric vehicle utilizes a different transaxle than does the gasoline vehicle. The different transaxles are identified by labels on the driver side axle tubes and are not interchangeable.

***NOTE:** This section pertains to the electric vehicle transaxle only.*

LUBRICATION

See General Warning on page 1-1.

There are two plugs located on the lower half of the transaxle housing. The upper plug (21) (as viewed when the vehicle is on a level surface) is used as a lubricant level indicator (**Figure 28-5, Page 28-3**). When the vehicle is parked on a level surface, the lubricant level should be even with the bottom of the hole. The lower plug (22) is for draining the lubricant. When draining the lubricant, the upper plug should be removed so the lubricant will drain faster. Be sure the drain plug is installed before filling. **See following NOTE.**

***NOTE:** Recycle or dispose of used oil or lubricant in accordance with local, state, and federal regulations.*

AXLE BEARING AND SHAFT

See General Warning on page 1-1.

AXLE SHAFT

Axle Shaft and Oil Seal Removal

1. Disconnect the battery cables as instructed. **See WARNING “To avoid unintentionally starting...” in General Warning on page 1-2.**
2. Place chocks at the front wheels. Loosen lug nuts on rear wheels and lift the rear of the vehicle with a chain hoist or floor jack. Place jack stands under the axle tubes to support the vehicle. **See WARNING “Lift only one end...” in General Warning on page 1-1.**
3. Remove the rear wheel and brake drum. **See Brake Shoe Removal on page 6-1.**

4. Use 90° internal snap ring pliers to remove the internal retaining ring (6) from the axle tube. **(Figure 28-1, Page 28-2). See also Figure 28-1, Page 28-2.**
5. Remove the axle, retaining ring, and bearing assembly by pulling the axle straight out of the housing.
6. If necessary, remove the axle oil seal (15) and adapter ring (39) **(Figure 28-5, Page 28-3).**
 - 6.1. Use a bearing puller (CCI P/N 1016417) to remove the axle seal and adapter ring from the axle tube **(Figure 28-2, Page 28-2). See following CAUTION and NOTE.**

CAUTION

- Do not scar or damage the inside surfaces of the tube when removing the oil seal and adapter ring. A damaged tube might have to be replaced.

NOTE: Do not discard the adapter ring. If the adapter ring is lost or damaged, the axle tube will have to be replaced.

- 6.2. Use a press to separate the axle oil seal (15) from the adapter ring (39) **(Figure 28-3, Page 28-2).** Retain the adapter ring and discard the oil seal.
7. Inspect the axle shaft assembly to be sure the bearing and collar have not slipped and are still seated against the shoulder on the axle shaft.
8. Inspect bearing (5) **(Figure 28-5, Page 28-3).** If the bearing in a Type G transaxle is worn or damaged, the entire axle shaft assembly (1 or 2) must be replaced.

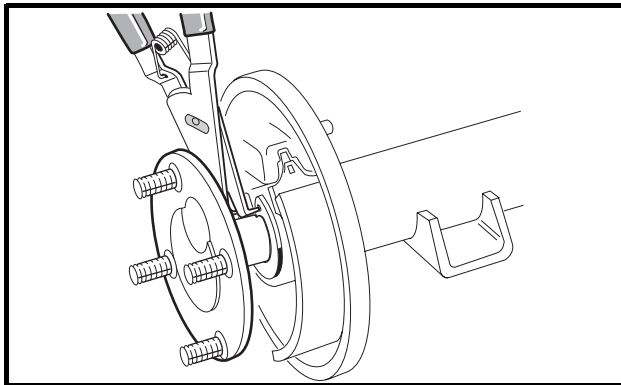

Figure 28-1 Axle Tube

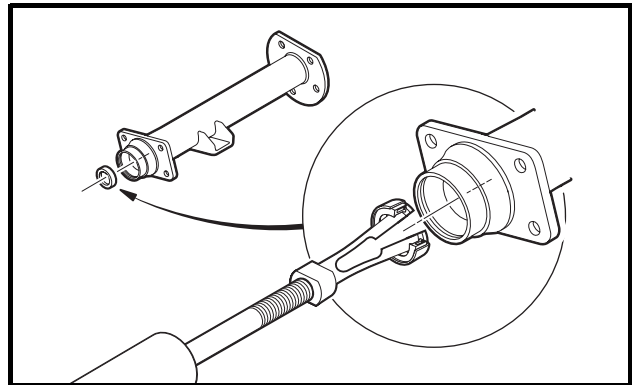

Figure 28-2 Axle Seal and Adapter Ring Removal

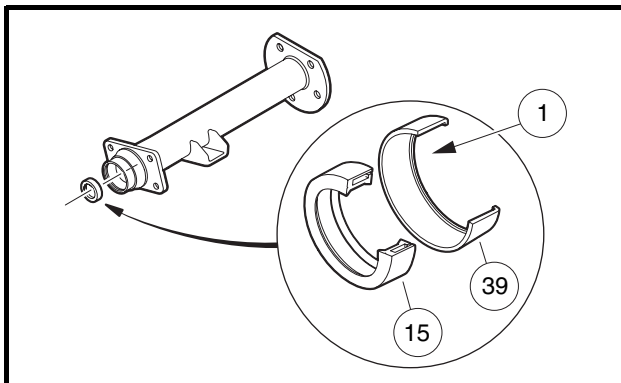

Figure 28-3 Axle Seal and Adapter Ring

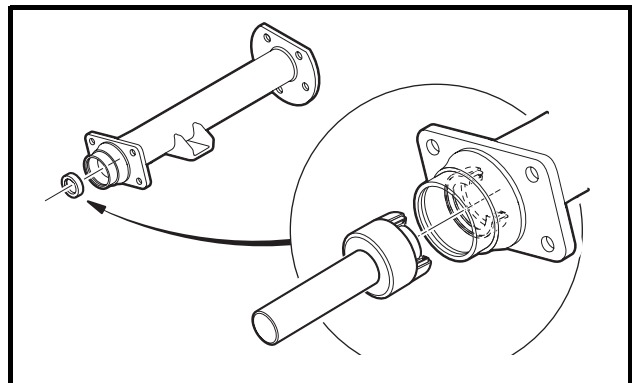

Figure 28-4 Axle Seal and Adapter Ring Installation

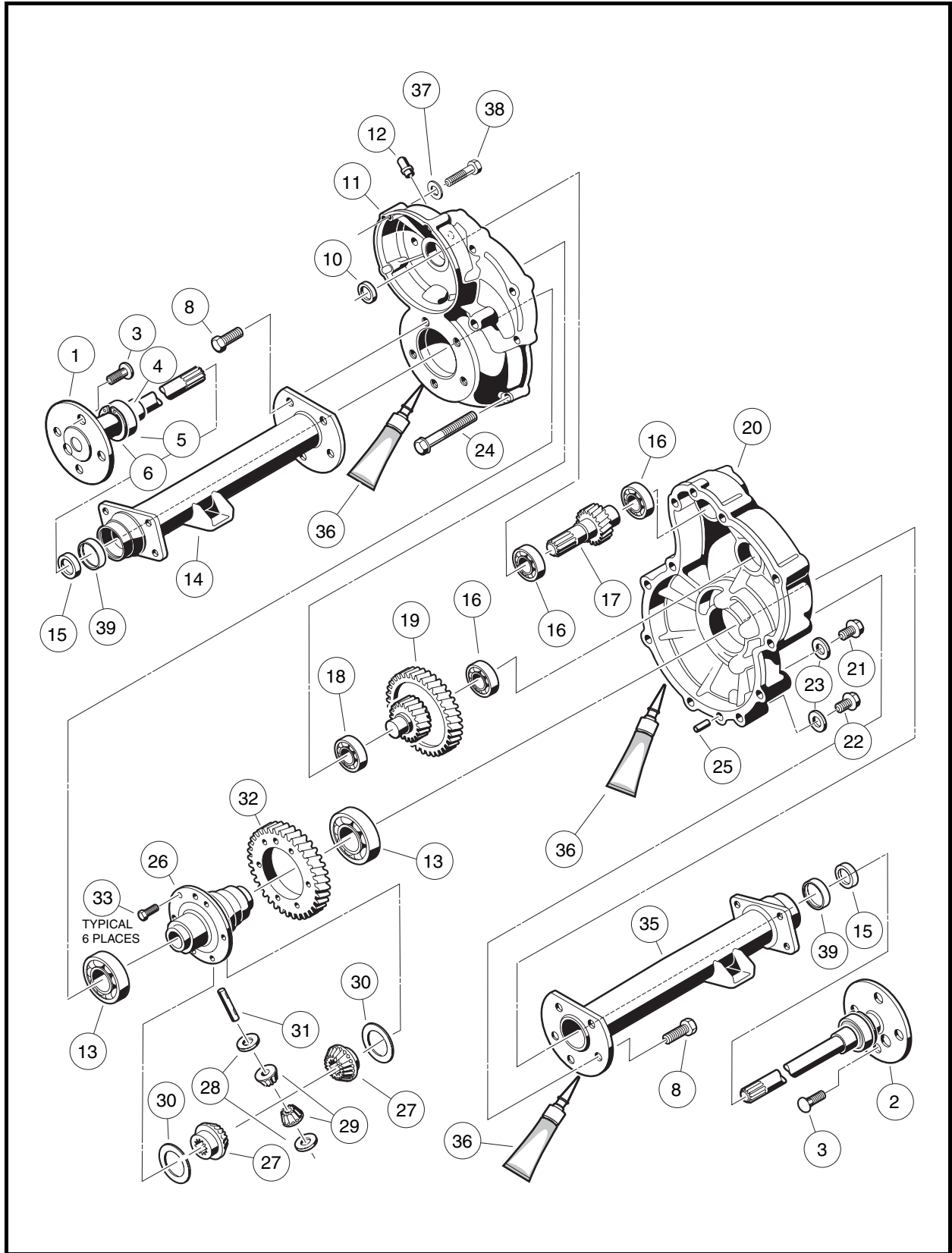

Figure 28-5 Axles And Tubes

Axle Shaft and Oil Seal Installation

1. If previously removed, install a new oil seal.
 - 1.1. Clean seal seat in the adapter ring (39) (**Figure 28-3, Page 28-2**).
 - 1.2. Place a new seal (15) in the adapter ring with the seal lip facing toward the adapter ring lip (1) (**Figure 28-3, Page 28-2**). Use an axle seal tool (CCI P/N 1014162) and mallet to tap it in until it seats firmly in position (**Figure 28-3, Page 28-2**). A hydraulic press may also be used with the axle seal tool.
 - 1.3. Clean adapter ring seat(s) in the axle tube (14 or 35) (**Figure 28-5, Page 28-3**).
 - 1.4. Apply Loctite[®] 603 (36) to the outer diameter of the adapter ring.
 - 1.5. Place the oil seal and adapter ring assembly into the axle tube with the seal lip facing away from the bearing (**Figure 28-4, Page 28-2**). Use an axle seal tool (CCI P/N 1014162) and mallet to tap it in until it seats firmly in position. **See following CAUTION.**

⚠ CAUTION

- **Clean any residual oil from the exposed end of the axle shaft and from the oil seal area prior to installing the axle shaft to prevent oil from coming in contact with brakes**

2. Install the rear axle into the transaxle. **See following NOTE.**

NOTE: *If the retaining ring (6), axle bearing (5), or sleeve (4) must be replaced, the entire axle shaft assembly (1 or 2) must be replaced (**Figure 28-5, Page 28-3**).*

- 2.1. Insert the shaft, splined end first, through the seal and into the axle tube. Be careful not to damage the seal on the inside of the axle tube hub. Advance the shaft through to the bearing on the shaft, then rotate it to align the shaft splines with the splined bore of the differential side gear (27) (**Figure 28-5, Page 28-3**). Continue advancing the shaft until the bearing on the axle is firmly seated within the axle tube hub seat.
- 2.2. Use a pair of snap ring pliers to install the retaining ring (6) inside axle tube hub so that it seats against the axle bearing assembly and into the machined slot in the inside wall of the axle tube hub (**Figure 28-5, Page 28-3**). **See preceding NOTE.**
- 2.3. Place a 1/4 to 3/8-inch (6 to 10 mm) diameter rod against the retaining ring and tap lightly at four to five locations around the retaining ring to ensure it is properly seated. **See following WARNING.**

⚠ WARNING

- **Be sure the retaining ring is properly seated in its groove. If the ring is not properly installed, the axle assembly will separate from the transaxle and damage the axle assembly and other components. Loss of vehicle control could result, causing severe personal injury or death.**

3. If a new oil seal was installed, allow 24 hours before operating the vehicle to allow the Loctite 603 to fully cure.

AXLE BEARING

Do not remove the axle bearing (5) from a Type G transaxle. If bearing is worn or damaged, the entire axle assembly (1 or 2) must be replaced (**Figure 28-5, Page 28-3**).

TRANSAXLE

See General Warning on page 1-1.

TRANSAXLE REMOVAL

1. Place chocks at the front wheels and slightly loosen lug nuts on both rear wheels.
2. Place a floor jack under the transaxle and raise the rear of the vehicle. Position jack stands under the frame crossmember between the spring mount and the side stringer, just forward of each rear wheel. Lower the vehicle to let the jack stands support the vehicle (**Figure 28-6, Page 28-5**). See **WARNING “Lift only one end of the vehicle…”** in General Warning on page 1-1.
3. Remove the rear wheels, then thread one lug nut onto a stud on each rear hub. This will keep the brake drums on the hubs.
4. Remove the bow-tie pins (1), brake cable clevis pins (2), and cable retaining E-clips (3). Disconnect the brake cables (4) (**Figure 28-7, Page 28-5**).

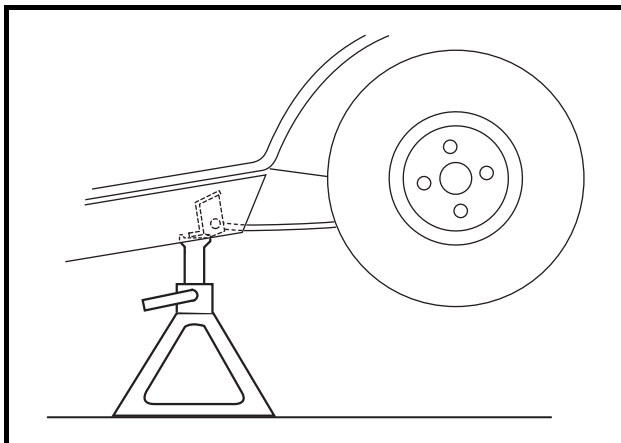

Figure 28-6 Vehicle Supported on Jack Stands

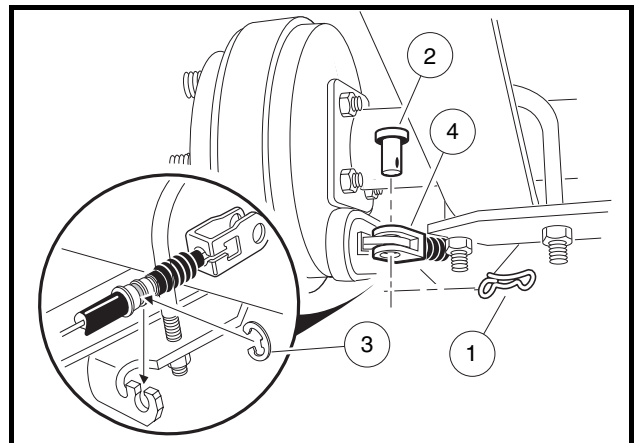

Figure 28-7 Disconnect Brakes

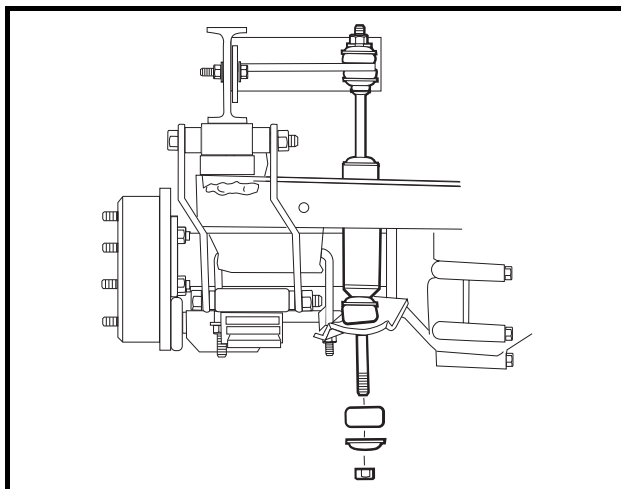

Figure 28-8 Disconnect Shocks

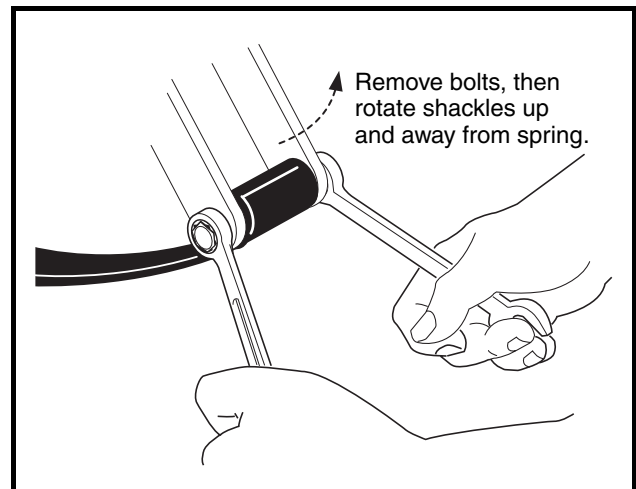

Figure 28-9 Shackles

5. Disconnect the shock absorbers from their lower mounts (**Figure 28-8, Page 28-5**).
6. Disconnect the four motor wires. Use two wrenches to prevent the post from turning.
7. With a floor jack supporting the transaxle, remove lower spring shackle nuts and bolts. Position shackles so they are clear of springs (**Figure 28-9, Page 28-5**).
8. If a chain hoist was used to raise the vehicle, lift the vehicle high enough to permit easy access and clearance for removal of the motor. If a floor jack was used to raise the vehicle, lower the transaxle enough to permit easy access and clearance for removal of the motor.
9. Remove the three motor mounting bolts (**Figure 28-11, Page 28-6**), and the motor positioning bolt (**Figure 28-11, Page 28-6**), mounting the motor to the transaxle. **See following CAUTION.**

⚠ CAUTION

- **Do not position fingers under motor when sliding motor off of the input shaft. Fingers may get pinched when motor disengages.**

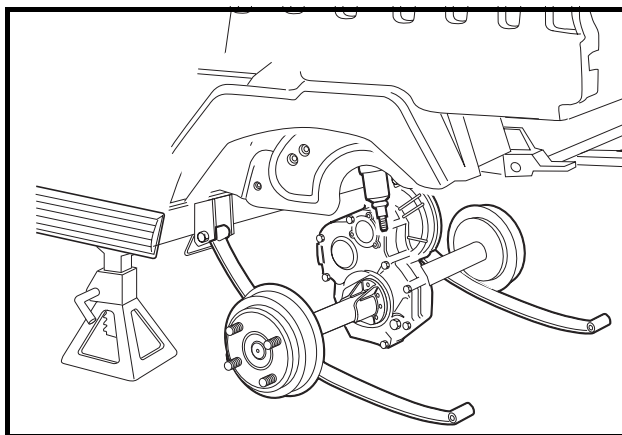

Figure 28-10 Leaf Springs

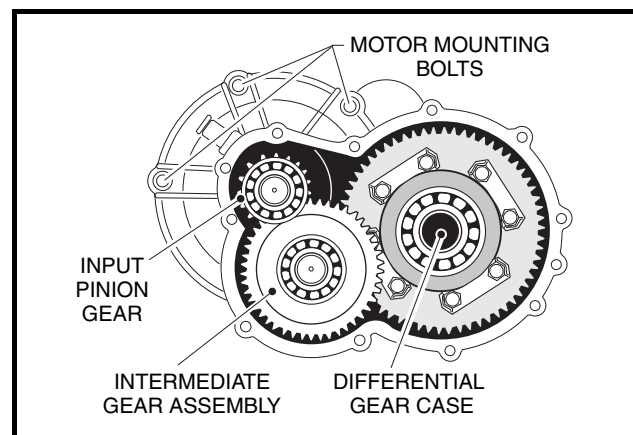

Figure 28-11 Motor And Gear Assembly

10. Carefully remove the motor from the transaxle. Slide the motor away from the transaxle until the motor spline becomes disengaged from the input shaft, then lift motor out. **See preceding WARNING.**
11. If a floor jack was used, pull floor jack from beneath the transaxle and allow the springs to rest on the floor.
12. Remove the U-bolts attaching the transaxle to the leaf springs (**Figure 28-10, Page 28-6**).
13. Carefully lift each end of the transaxle off its positioning pin (on the leaf spring) and slide the transaxle to the rear and out of the vehicle.
14. Drain the lubricant from the transaxle and remove the axle shafts. **See Axle Shaft and Oil Seal Removal on page 28-1. See following NOTE.**

NOTE: *Recycle or dispose of used oil or lubricant in accordance with local, state, and federal regulations.*

15. Remove the brake assemblies if required. **See Brake Cluster Removal on page 6-8..**

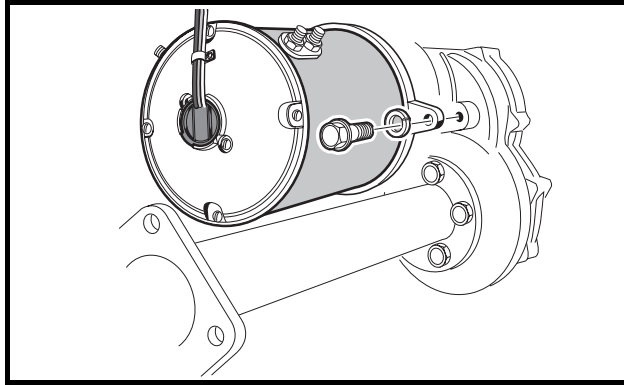

Figure 28-12 Motor Positioning Bolt

TRANSAXLE DISASSEMBLY, INSPECTION, AND ASSEMBLY

See General Warning on page 1-1.

TRANSAXLE DISASSEMBLY AND INSPECTION

1. To detach axle tubes (14 and 35) from the transaxle housing, remove the bolts (8) (**Figure 28-5, Page 28-3**).
2. Remove 11 bolts (24) that hold housing together.
3. Pull the halves of the housing (11 and 20) apart. If necessary, tap lightly on the spline of the input pinion (17). **See following CAUTION.**

CAUTION

- To prevent damage to the housing mating seal surfaces, use caution when separating halves.
4. Remove input pinion gear (17) by pulling gear out while rocking intermediate gear assembly (19). Lift intermediate gear assembly and differential gear case unit out simultaneously (**Figure 28-5, Page 28-3**). **See following CAUTION.**

CAUTION

- Do not damage gears. Use extreme care when handling them.
5. Use a bearing puller or arbor press to remove bearings (16) from the input pinion gear. If the oil seal (10) is damaged, replace it (**Figure 28-5, Page 28-3**). **See following CAUTION.**

CAUTION

- Do not reuse bearings after removing them. Replace bearings with new ones.
6. To disassemble the intermediate gear assembly, press off together the bearing (16) and the gear (19) (**Figure 28-5, Page 28-3**). **See also Figure 28-13, Page 28-8.**
 7. Press the bearing (18) off the intermediate gear assembly (**Figure 28-5, Page 28-3**). **See also Figure 28-13, Page 28-8.**

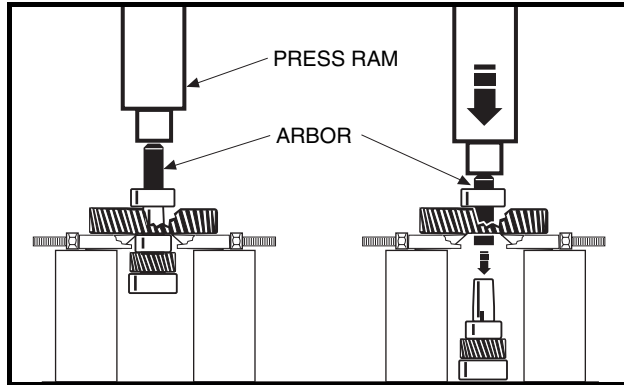

Figure 28-13 Intermediate Gear Assembly

8. Disassemble the differential gear case:
 - 8.1. Remove the hex bolts (33) and the ring gear (32) from the differential case (26) (**Figure 28-5, Page 28-3**).
 - 8.2. Remove the ring gear.
 - 8.3. Separate the differential gear case housing. If necessary, install two of the hex bolts (removed previously in step 8.1.) into the differential gear unit and, while holding the unit slightly above the work area, lightly tap the bolt heads (**Figure 28-14, Page 28-8**). Remove the two bolts.

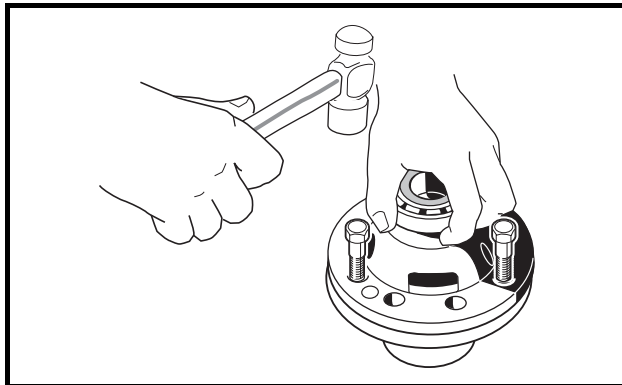

Figure 28-14 Separate Housing

- 8.4. Remove the differential pin (31) by pushing pin through differential gear case from one side (**Figure 28-5, Page 28-3**). **See also Figure 28-15, Page 28-9.**
- 8.5. Remove the idler gears and thrust plates (1 and 2) (**Figure 28-16, Page 28-9**).
- 8.6. Remove the differential gears and thrust plates (3 and 4).
- 8.7. Inspect the bearings (13) of the differential case (26) and replace them if they are damaged (**Figure 28-5, Page 28-3**). To remove them, press them off. **See following CAUTION.**

CAUTION

- Do not reuse bearings after removing them. Replace bearings with new ones.

9. Inspect parts for wear or damage. Any worn or damaged parts should be replaced. **See following NOTE.**

NOTE: Damaged or worn gears should be replaced as sets.

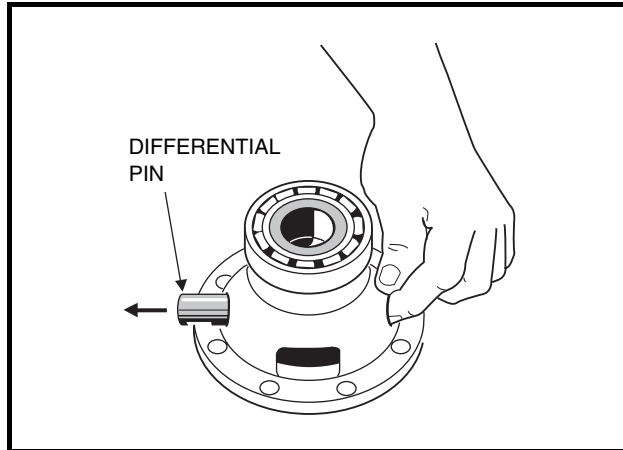

Figure 28-15 Differential Pin

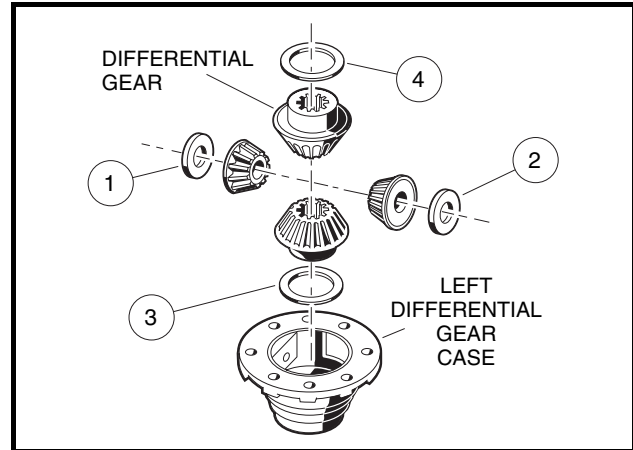

Figure 28-16 Left Differential

TRANSAXLE ASSEMBLY

CAUTION

- Do not press against the bearing outer race.
- The housing and all parts must be wiped clean and dry before reassembly.

1. If bearings (13) were removed during disassembly, install new bearings using an arbor press (**Figure 28-5, Page 28-3**).
2. Assemble the differential gear case.
 - 2.1. Install the pin (31) (**Figure 28-5, Page 28-3**). Apply a small amount of oil to all thrust plates and to both ends of the pin.
 - 2.2. Install the hex bolts (33) and output gear (32). Tighten bolts to 58 ft-lb (78.6 N·m).
3. Press a new bearing (18) onto the intermediate gear assembly (**Figure 28-5, Page 28-3**).
4. Press new bearing (16) onto input pinion gear (17).
5. Apply grease to the lip of the new oil seal (10) and install the seal using a transaxle pinion seal tool (CCI P/N 1014161). The lip of the oil seal should face the inside of the transaxle housing. Make sure the seal is firmly seated.
6. Install the differential assembly, the intermediate gear assembly, and the input pinion gear simultaneously. Be sure all bearings are seated properly in the housing. Rotate the input shaft to check for smooth gear operation (**Figure 28-11, Page 28-6**).
7. Install both dowel pins (25) in the transaxle housing (20) (**Figure 28-5, Page 28-3**).
8. Install left half of transaxle housing:
 - 8.1. Place a 1/8-inch (3 mm) bead of Three Bond liquid gasket on mating surface of housing.
 - 8.2. Install left half of transaxle housing (20) (**Figure 28-5, Page 28-3**).
 - 8.3. Install eleven bolts (24) in the case housing and tighten to 19 ft-lb (25.7 N·m). Type G transaxles have no shims or gasket.
 - 8.4. Install axle tube (14 and 35) with bolts (8) (**Figure 28-5, Page 28-3**). Tighten the bolts to 37 ft-lb (50.2 N·m).
9. Install the brake assemblies as instructed. **See Brake Cluster Installation on page 6-9.**

10. Apply a small amount of grease to the lip of the oil seal (15) (**Figure 28-5, Page 28-3**). **See following CAUTION.**

⚠ CAUTION

- **Clean any residual oil from the exposed end of the axle shaft and from the oil seal area prior to installing the axle shaft to prevent oil from coming in contact with brakes**
11. Install the rear axle onto the transaxle.
 - 11.1. Insert the splined end of the axle shaft into the axle tube. Be careful not to damage the seal on the inside of the axle tube hub. Advance the shaft through to the bearing on the shaft, and rotate it to align the shaft splines with the splined bore of the differential gear. Continue advancing the shaft until the bearing on the axle is firmly seated within the axle tube hub seat.
 - 11.2. Using 90° internal snap ring pliers (0.090 tip) (CCI P/N 1012560), attach the internal retaining ring into the axle tube hub so that it seats against the axle bearing assembly and into the machined slot in the inside wall of the axle tube hub (**Figure 28-5, Page 28-3**).
 - 11.3. Place a 1/4 to 3/8-inch (6 to 10 mm) diameter rod against the retaining ring and tap lightly at four or five locations to ensure it is properly seated. **See following WARNING.**

⚠ WARNING

- **Be sure retaining ring is properly seated in its groove. If ring is not properly installed, the axle assembly will separate from the transaxle and damage the axle assembly and other components. Loss of vehicle control could result in severe personal injury or death.**
12. Make sure the drain plug (22) is installed in the transaxle and tightened to 23 ft-lb (31 N·m). Fill the transaxle, through the level indicator hole, with 22 ounces of SAE 30 API Class SE, SF, or SG oil (a higher grade may also be used). Install and tighten the level indicator plug (21) to 23 ft-lb (31 N·m).

TRANSAXLE INSTALLATION

See General Warning on page 1-1.

1. If using a chain hoist, raise the vehicle and place transaxle in position on the jack stands. If using a floor jack, lower the jack stands to their lowest settings and place the transaxle in position on the jack stands. **See WARNING “Lift only one end of the vehicle...” in General Warning on page 1-1.**
2. Align the center hole in the saddle of the transaxle with the pilot bolt in the leaf spring assembly.
3. Install the two U-bolts, jounce bumper mount (if required), and spacers, lockwashers, and nuts. Tighten the nuts to 25 ft-lb (34 N·m). Tighten the U-bolt nuts so an equal amount of thread is visible on each leg of the bolt.
4. Install the motor. **See Section 26 – Motor (Model 5BC59JBS6390) or Section 27 – Motor (Model EJ4-4001).**
5. If using a chain hoist, lower the vehicle while guiding the leaf springs into the rear spring shackles. If using a floor jack, raise the differential while guiding the leaf springs into the rear spring shackles. Then raise the jack stands to support the transaxle.
6. Connect the four motor wires. Tighten the retaining nuts to 65 in-lb (7.3 N·m). Use two wrenches to prevent the posts from turning. **See following NOTE.**

NOTE: If the motor wires were not tagged when disconnected, refer to the wiring diagram for proper connection. **See Wiring Diagram on page 21-2.**

7. Insert bolts through the spring shackles and bushings in the leaf spring eyes. Secure bolts with locknuts. Tighten to 15 ft-lb (20.3 N·m).
8. Connect the brake cables using new bow tie pins (1) (**Figure 28-7, Page 28-5**).
9. Install the shock absorbers. Tighten shock absorber retaining nuts until the rubber bushings expand to the same size as the cup washers.
10. Install the rear wheels and finger-tighten the lug nuts.
11. Lift the vehicle and remove the jack stands.
12. Lower vehicle and tighten the lug nuts, using a crisscross pattern, to 55 ft-lb (74.6 N·m).
13. Inspect the vehicle to check for proper operation. **See following WARNING.**

⚠ WARNING

- **Make sure that the vehicle operates in the forward direction when the Forward/Reverse switch is in the FORWARD position.**
- **Make sure that the vehicle operates in the reverse direction when the Forward/Reverse switch is in the REVERSE position. The reverse buzzer will sound as a warning when the Forward/Reverse switch is in REVERSE.**
- **Make sure that the vehicle does not operate when the Forward/Reverse switch is in the NEUTRAL position.**

SECTION 29 – IQ DISPLAY MODULE (IQDM-P) PROGRAMMING

⚠ DANGER

- See General Warning on page 1-1.

⚠ WARNING

- See General Warning on page 1-1.

PLUGGING THE HANDSET INTO THE VEHICLE

1. Connect one end of the cable to the jack located on the bottom of the handset.
2. Connect the cable adaptor to the IQDP-P cable.
3. Find the IQDM jack on the vehicle (**Figure 29-1, Page 29-1 or Figure 29-2, Page 29-1**).
4. Remove the dust cap from the IQDM jack.
5. Align the keyed portion of the plug with the IQDM jack and connect the plug to the jack.

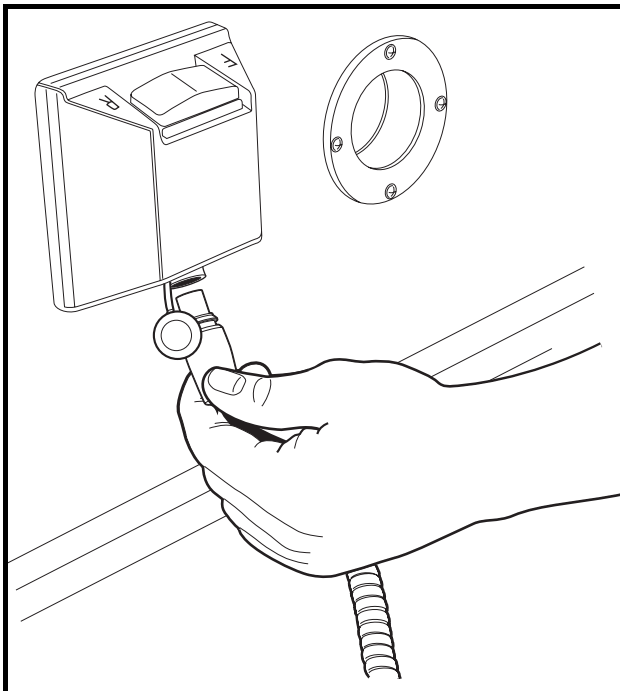

Figure 29-1 IQDM Jack On F&R Switch Housing

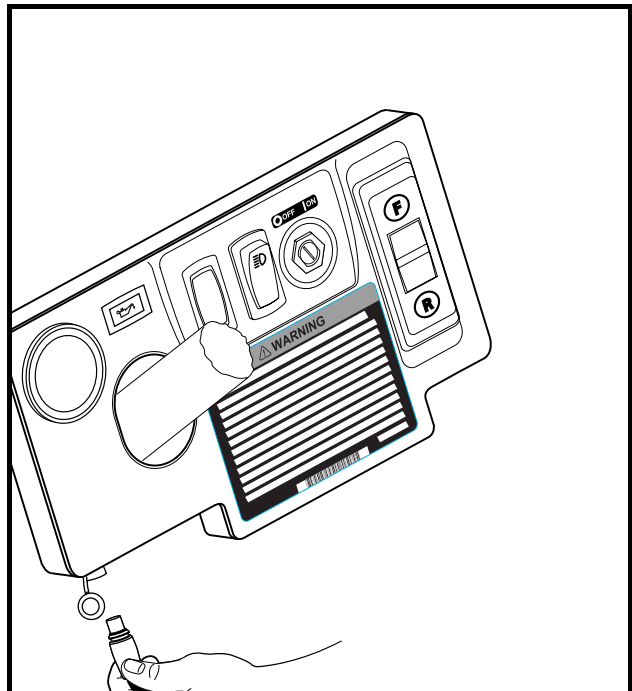

Figure 29-2 IQDM Jack Under Instrument Panel

PROGRAM MENU

The *program* menu can be accessed by pressing the right arrow on the navigation button when the square beside *program* is blinking (**Figure 29-3, Page 29-2**). When the *program* menu is active, use the up or down arrows on the navigation button to go to the desired item in the *program* menu. Again, press the right arrow to select the menu item. Use the change value button to change the values of the selected item as necessary.

The following parameters can be programmed with the handset from the *program* menu:

SPEED SETTING

The vehicle's top speed can be changed by selecting values 1 through 3 (**Figure 29-4, Page 29-2**). If a value of 4 is displayed for the speed setting, a special access code has been entered to place the vehicle in "private speed mode." A speed setting of 4 cannot be selected with the *speed setting* menu item. For additional information on speed setting 4, refer to Code A, Code B, and Code C. **See Code A, Code B, and Code C on page 29-3.**

SPEED SETTING	DESCRIPTION	VEHICLE SPEED
1	Commercial speed	8.0 mph (12.9 km/h)
2	Slow golf speed	13.4 mph (21.6 km/h)
3	Normal golf speed	14.8 mph (23.8 km/h)
4	Private speed mode	19.6 mph (31.5 km/h)

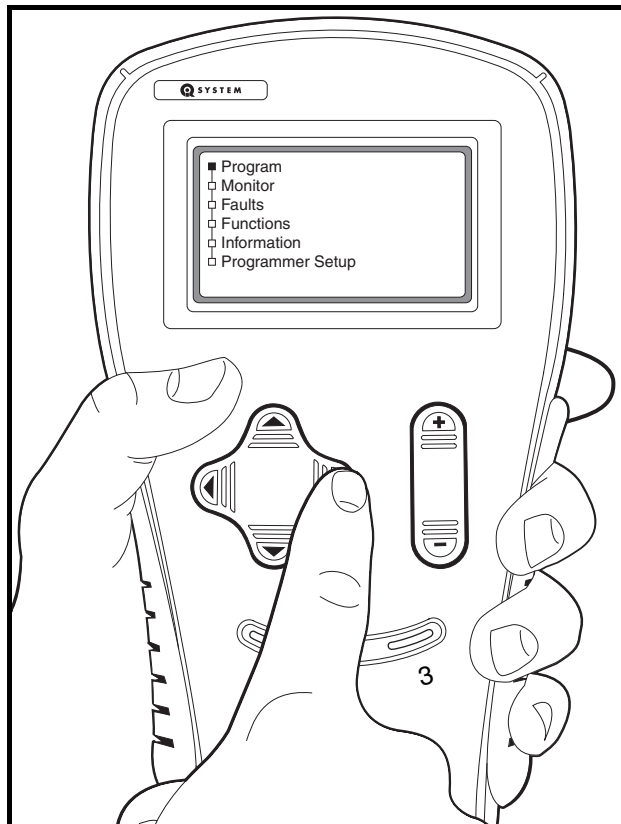

Figure 29-3 Access Program Menu

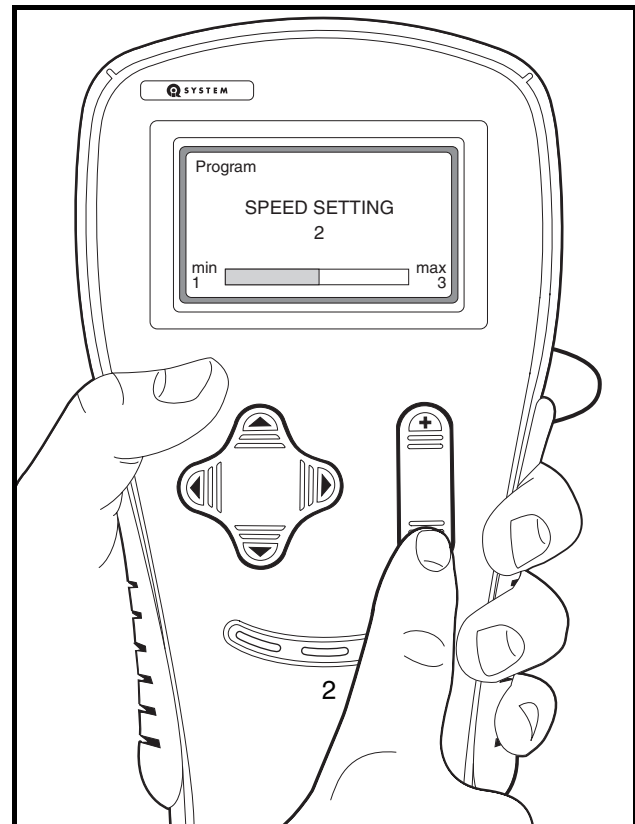

Figure 29-4 Change Speed Setting

FAST ACCEL

Fast accel (fast acceleration) is an option that can be enabled or disabled. With *fast accel* turned on, the vehicle will accelerate at a noticeably faster rate. With this feature turned off, the vehicle speed will gradually increase, even if the accelerator is quickly pressed to the floor. Turn the feature on or off by pressing + or – on the change value button.

PEDAL UP MODE

Three options exist for *pedal up mode* (motor braking). When the accelerator pedal is released, motor braking will slow the vehicle to a speed of approximately 11 mph (17.7 km/h) when pedal up motor braking is enabled (option 1 or 2). If pedal up motor braking is disabled (option 0), the vehicle will coast to a stop when the pedal is released. **See following NOTE.**

Change the settings of the Pedal Up Mode by pressing + or – on the change value button.

NOTE: *If the accelerator pedal is released when the vehicle is going down an incline, the motor braking function will activate, slowing the vehicle to approximately 11 mph, depending on the slope of the incline. See Speed Setting on page 29-2.*

PEDAL UP MODE SETTING	MODE	OPERATION DESCRIPTION
0	Off	Pedal up motor braking is disabled
1	Mild pedal up	Mild pedal up motor braking
2	Aggressive pedal up	Aggressive pedal up motor braking

SPEED CAL

The *speed cal* (speed calibration) menu item allows the user to fine tune the vehicle speed. This feature cannot be used to increase the vehicle speed. The range for speed calibration is 0 to 10. Each time the number is increased, the top speed will be decreased by 0.12 mph (0.2 km/h). The top vehicle speed will be determined by the *speed setting* menu item and the speed calibration setting. For example, if the speed setting is set for a value of 3 (14.8 mph (23.8 km/h)), and the speed calibration is set for 5, the total top speed of the vehicle should be approximately 14.2 mph (22.9 km/h).

CODE A, CODE B, AND CODE C

The code entries are used to place the vehicle in “private speed mode”, speed setting code 4. Each vehicle has a unique code for placing the vehicle in this mode. A vehicle programmed for “private speed mode”, speed setting 4, does not conform to ANSI Z130.1 – American National Standard for Golf Cars – Safety and Performance Specifications because it is capable of speeds in excess of 15 mph (24.1 km/h). For more information on this feature, contact your local Club Car distributor or dealer.

A**accelerator**

- cable
 - installation 16-11
 - removal 16-10
- pedal (gas, V-Glide)
 - installation 5-7
 - removal 5-5
- pedal (MCOR)
 - installation 5-10
 - removal 5-8
- pedal height adjustment
 - electric (MCOR) 5-19
 - gasoline vehicle 5-14
- pedal limit switch
 - testing 12-14
- rod
 - installation and adjustment 16-7
 - removal 16-7
- rod adjustment (gasoline vehicle) 5-14

air box

- installation 16-13
- removal 16-13

air filter 16-16

- replacement 16-16

armature

- see starter/generator

armature, motor

- see motor, armature

axle

- bearing
 - installation 18-5, 19-5
 - removal 18-3, 19-3
- shaft
 - installation 18-5, 19-5
 - oil seal 18-2, 19-2
 - removal 18-2, 19-2

B**batteries** 24-1

- see *also* battery charger
- care 24-9
- charging 24-12
- deep discharge 24-14
- electrolyte
 - adding water (mineral content) 24-11
 - level 24-10
- excessive early discharging 24-15
- fleet rotation 24-15
- hydrometer calibration 24-4
- maintenance, preventive 24-9
- see *also* batteries, electrolyte

- replacement 24-8
- self-discharge 24-10
- storage 24-15
- testing 24-3
 - discharge test 24-5
 - interpreting test results 24-6
 - hydrometer test 24-3
 - interpreting results 24-4
 - on-charge voltage test 24-3
 - voltage test 21-10
 - voltage test (under load) 21-15
- troubleshooting examples 24-7
- vibration damage 24-11

battery

- hydrometer test 11-9, 12-9
- installation 13-33, 14-33
- load test 11-11
- storage 13-33, 14-33
- testing 11-9, 11-31, 12-9
- testing under load 12-11, 12-30
- voltage test 11-11, 12-11

battery charger

- 16 hour shut-off 24-14
- AC service, incoming 24-15
- numbering vehicles and chargers 24-15
- testing 24-3
 - on-charge voltage test 24-3

battery warning light

- installation 23-17
- removal 23-17
- testing 21-32

bearing, axle

- see transaxle, type g, axle bearing

bearing, motor

- see motor, bearing

belt, drive

- see drive belt

body, front

- see *also* repair, front and rear body
- installation 4-4, 4-7
- removal 4-3, 4-7

body, rear

- installation 4-19
- removal 4-12, 4-15

brakes

- adjustment 6-8
- cable
 - installation 6-11
 - removal 6-10
- cleaning assembly 6-5

- cluster
 - installation 6-9
 - removal 6-8
- pedal
 - free play adjustment
 - electric (MCOR) 5-17
 - gasoline vehicle 5-12
 - height adjustment
 - electric (MCOR) 5-16
 - gasoline vehicle 5-11
 - installation 5-2
 - removal 5-1
- shoe
 - installation 6-6
 - removal 6-1
- braking, motor**
 - see regenerative braking
- braking, regenerative**
 - see regenerative braking
- breather valve (reed valve)** 15-3
- C**
- Camber** 7-13
- camber**
 - adjustment 7-13
- carburetor** 16-1
 - closed throttle or idle adjustment 16-11
 - jet, main 16-3
 - elevation/size chart 16-3
- CAUTION**
 - definition of 1-1
- charger receptacle**
 - fuse link 23-16
 - installation 23-16
 - removal 23-16
 - installation 23-15
 - removal 23-15
 - testing 21-28
- choke**
 - choke and air intake system 16-12
- choke button**
 - installation 16-12
 - removal 16-12
- cleaning**
 - brake assembly 6-5
 - seat 4-1
 - vehicle body 4-1
- clutch (torque converter) troubleshooting** 20-1
- clutch, drive**
 - see drive clutch
- clutch, driven**
 - see driven clutch
- column, steering**
 - see steering column
- communication display module (CDM)**
 - function codes 21-33
 - retrieving data from 21-34
 - troubleshooting 21-35
- commutator**
 - see starter/generator
- connector, 16-pin**
 - see test procedures
- crankcase cover**
 - installation 15-5
 - removal 15-3
- cylinder head** 15-3
- D**
- DANGER**
 - definition of 1-1
- diagram, wiring** 12-6
- differential**
 - see transaxle, type g
 - see unitized transaxle
- diode**
 - testing 11-18
- diode, headlight**
 - testing 11-37, 12-35
- diode, pin 9**
 - testing 21-24
- diode, solenoid**
 - testing 21-12
- drive belt**
 - inspection 20-2
 - installation 20-3
 - removal 20-2
- drive clutch**
 - assembly 20-10
 - cleaning and inspection 20-5, 20-9
 - disassembly 20-7
 - installation 20-12
 - removal 20-4
- drive motor**
 - see motor
- drive unit**
 - see transaxle, type g
 - see unitized transaxle
- driven clutch**
 - assembly 20-13
 - disassembly 20-12
 - inspection 20-13
 - installation 20-16
 - removal 20-12

E

- electric motor**
 - see motor
 - electrical system** 12-8, 21-1
 - circuits 11-5
 - engine ignition circuit
 - see also ignition coil and ignition testing
 - key-start 11-5
 - lockout cam circuit 11-5
 - testing circuits 21-10
 - engine**
 - assembly 15-9
 - removal 15-3
 - rotation 15-1
 - RPM adjustment 16-12
- F**
- floor mat**
 - installation 4-19
 - removal 4-19
 - flywheel**
 - removal 15-6
 - forward/reverse**
 - cable
 - adjustment 18-20, 19-21
 - installation 18-19, 19-19
 - removal 18-19, 19-19
 - handle (lever) 18-1, 19-1
 - Forward/Reverse switch**
 - installation 23-5, 23-6
 - removal 23-4, 23-6
 - testing 21-30
 - front body**
 - see body, front
 - fuel filter**
 - installation 16-17
 - removal 16-17
 - fuel gauge/hour meter** 14-21
 - fuel gauge circuit
 - testing 11-33
 - fuel gauge circuit testing 12-32
 - fuel level sending unit 14-22
 - testing 11-32
 - fuel level sending unit testing 12-31
 - hour meter circuit
 - testing 11-35
 - hour meter circuit testing 12-33
 - installation 14-21
 - operation 13-21
 - removal 14-21

- fuel gauge/hour meter (gasoline vehicles)**
 - hour meter circuit testing 12-33
 - operation 13-21
- fuel level sending unit** 14-22
 - testing 11-32
- fuel level sending unit testing** 12-31
- fuel lines** 16-25
- fuel pump** 16-19
 - assembly 16-20
 - cleaning and inspection 16-20
 - disassembly 16-19
 - installation 16-21
 - removal 16-19
- fuel shut-off valve** 16-25
- fuel tank** 16-21
 - disposal 16-23
 - installation 16-23
 - removal 16-22
 - storage 16-23
- fuse**
 - installation 14-15
 - removal 14-14
 - testing 11-11, 12-12
- fuse, sense lead** 21-28

G

- generator circuit**
 - troubleshooting 11-20
- governor**
 - governor system 18-1, 19-1
- governor cable**
 - installation and adjustment 16-9
 - removal 16-9
- ground cable testing** 12-12
- ground cables**
 - testing 11-12

H

- headlight bulb**
 - installation 14-27
 - removal 14-26
- headlight switch**
 - installation 14-29
 - removal 14-29
 - testing 11-36, 12-34
- headlights**
 - see also lighting circuit
 - testing 11-37, 12-35

- high pedal detect** 21-4
hydrometer test 11-9, 12-9
- I**
- ignition**
 testing 11-22
- ignition coil**
 installation 14-24, 15-8
 removal 14-23, 15-6
 testing 11-23, 12-21
- ignition testing** 12-20
- inspection**
 drive clutch 20-5
 drive clutch parts 20-9
 driven clutch 20-13
 front wheel free play 7-19
 fuel pump 16-20
 motor
 armature ground test 26-5, 27-7
 armature inspection 26-5, 27-6
 bearing 26-7, 27-9
 brush 27-8
 brush spring 27-8
 field windings 26-6, 27-7
 motor components 26-6
 speed sensor magnet 26-9, 27-9
 shock absorber 9-1
 spark plug 15-2
 starter/generator
 armature 14-6
 bearing 14-5
 brush spring 14-3
 brushes 14-2
 commutator 14-7
 field coils 13-8, 14-8
 transaxle, type g 28-7
- intake duct**
 installation 16-14
 removal 16-13
- K**
- key switch**
 engine kill circuit testing 11-28, 12-27
 installation 13-15, 13-16, 14-13, 23-1, 23-4
 removal 13-14, 14-12, 23-1, 23-2
 starter circuit testing 11-13
 starter circuit testing (pedal-start) 12-13
 testing 21-16
- kill circuit, engine**
 testing 11-28, 12-19, 12-28
- kill limit switch**
 installation 14-16
 removal 14-15
- kill limit switch, engine**
 testing 12-27
- kill wire, engine**
 testing 11-29
- L**
- leaf spring**
 see suspension, front *and* suspension, rear
- lockout cam**
 limit switch 11-15
 testing 11-31
- lockout cam circuit**
 function 11-5
- low oil warning light**
 installation 14-20
 removal 14-20
 testing 11-31, 12-29
- lubrication**
 front suspension 7-13
 transaxle, type g 28-1
- M**
- magnet, motor speed sensor**
 see motor, speed sensor magnet
- maintenance**
 batteries 24-9
- motor** 21-1, 22-1, 26-1, 27-1, 29-1
 armature
 ground test 26-5, 27-7
 inspection 26-5, 27-6
 assembly 26-10, 27-11
 bearing
 inspection 26-7, 27-9
 installation 26-7
 removal 26-7
 braking
 pedal down motor braking 21-1
 pedal up motor braking 21-1
 brush
 inspection 27-8
 brush spring
 inspection 27-8
 component
 inspection 26-6
 disassembly 26-4, 27-4
 features 21-1
 field winding inspection 26-6, 27-7
 identification 26-1, 27-1
 installation 26-12, 27-13
 motor braking 21-1
 protection circuit 21-4

- reconditioning 26-9, 27-11
 - removal 26-2, 27-2
 - service specifications 26-9, 27-11
 - speed sensor 26-15
 - installation 26-15
 - removal 26-15
 - testing 21-29
 - speed sensor magnet
 - inspection 26-9, 27-9
 - installation 26-9
 - removal 26-9
 - testing 21-14
 - see test procedures, motor
 - walk away braking 21-1
 - motor braking**
 - see regenerative braking
 - motor controller output regulator (MCOR)**
 - installation 23-9
 - removal 23-8
 - testing 21-12, 21-16
 - muffler**
 - see also exhaust system
 - installation 17-1
 - removal 17-1
- N**
- neutral lockout**
 - limit switch
 - installation 14-17
 - removal 14-16
 - testing 12-16
 - neutral lockout switch**
 - testing 12-30
- O**
- oil level sensor**
 - installation 15-5
 - removal 15-5
 - testing 11-30, 12-29
 - onboard computer** 21-4
 - onboard computer (OBC)**
 - installation 23-12
 - rebooting 21-32
 - removal 23-11
 - retrieving data from 21-34
 - testing 21-11, 21-28
- P**
- park brake**
 - adjustment
 - electric (MCOR) 5-17
 - gasoline vehicle 5-12
 - installation 5-4
 - removal 5-3
 - pedal group adjustment**
 - electric (MCOR) 5-16
 - gasoline vehicle 5-11
- R**
- rack and pinion**
 - assembly 7-10
 - disassembly 7-7
 - installation 7-12
 - removal 7-7
 - rear suspension**
 - see suspension, rear
 - receptacle**
 - see charger receptacle
 - regenerative braking** 21-1
 - repair**
 - front and rear body
 - gouges, punctures, tears 4-2
 - minor scratches and surface blemishes 4-2
 - tire 8-2
 - reverse buzzer**
 - installation 13-19, 14-18, 23-9
 - limit switch
 - installation 13-20, 14-19
 - removal 13-20, 14-19
 - testing 11-30, 12-28
 - removal 13-19, 14-18, 23-9
 - testing 11-30, 12-29, 21-31
 - RPM adjustment** 16-12
 - RPM limiter**
 - installation 14-23
 - removal 14-22
 - testing 11-23, 12-20
- S**
- safety** 1-1
 - schematic diagram** 12-6
 - serial number, vehicle** 3-1
 - service schedule**
 - see also periodic lubrication schedule
 - service tools**
 - torque converter kit 20-1
 - unitized transaxle 18-2, 19-2
 - shock absorber**
 - see suspension, front and suspension, rear
 - solenoid**
 - installation 14-14, 23-10
 - removal 14-14, 23-10
 - testing 11-15, 12-15, 21-30

- solenoid activating coil**
 testing 21-12
- spark plug** 15-1
 cleaning, inspection and repair 15-2
 gap adjustment 15-2
 installation 15-2
 removal 15-1
 testing 15-2
- specifications**
 torque 15-10
 vehicle 2-1
- speed controller**
 cloning 22-12
 connector, 16-pin
 see test procedures
 installation 23-13
 removal 23-13
- speed sensor**
 see motor, speed sensor
- stabilizer bar**
 see suspension, front *and* suspension, rear
- starter/generator**
 armature
 ground test 13-7, 14-7
 inspection 14-6
 servicing 14-4
 assembly 13-4, 13-8, 14-3, 14-9
 bearing
 cleaning 14-5
 inspection 14-5
 removal 14-5
 belt tension adjustment 13-10, 14-11
 brush spring
 inspection 14-3
 replacement 14-3
 brushes 14-2
 inspection 14-2
 replacement 14-2
 commutator 14-4
 armature replacement 14-7
 cleaning 14-7
 inspection 14-7
 disassembly 14-2, 14-4
 field coil
 inspection 13-8, 14-8
 removal 14-6
 installation 13-9, 14-10
 removal 13-1, 14-1
 rework 14-8
 testing 11-17, 11-20, 12-16, 12-18
- steering**
 adjustment 7-6
- rack and pinion
 assembly 7-10
 disassembly 7-7
 installation 7-12
 removal 7-7
- steering column**
 assembly 7-4
 disassembly 7-4
 installation 7-5
 removal 7-2
- steering wheel**
 installation 7-2
 removal 7-1
- storage**
 electric vehicle 3-4
 gasoline vehicle 3-2
- suspension, front**
 camber adjustment 7-13
 components
 delta a-plate
 installation 7-19
 removal 7-16
 kingpin and steering spindle
 installation 7-16
 removal 7-16
 leaf spring
 installation 7-15
 removal 7-15
 shock absorber
 installation 7-19
 removal 7-19
 wheel bearings and hub
 inspection 7-19
 installation 7-20
 removal 7-19
 lubrication 7-13
 toe-in adjustment 7-14
 wheel alignment 7-13
- suspension, rear**
 leaf spring
 installation 9-4
 removal 9-2, 9-4
 shock absorber
 inspection and removal 9-1
 installation 9-1
 stabilizer bar
 installation 9-7
 removal 9-7
- T**
- test procedures** 12-8
 1 – battery 12-9
 2 – fuse 12-12

- 3 – ground cables 12-12
- 4 – key switch starter circuit (pedal-start) 12-13
- 5 – accelerator pedal limit switch 12-14
- 6 – solenoid 12-15
- 7 – neutral lockout limit switch 12-16
- 8 – starter/generator 12-16
- 9 – wire continuity 12-18
- 10 – starter/generator 12-18
- 11 – voltage regulator 12-18
- 12 – engine kill circuit 12-19
- 13 – ignition test 12-20
- 14 – RPM limiter 12-20
- 15 – ignition coil 12-21
- 16 – kill limit switch 12-27
- 17 – key switch (engine kill circuit) 12-27
- 18 – engine kill circuit 12-28
- 19 – reverse buzzer limit switch 12-28
- 20 – reverse buzzer 12-29
- 21 – low oil warning light 12-29
- 22 – oil level sensor 12-29
- 24 – battery load test 12-30
- 24 – neutral lockout switch 12-30
- 25 – fuel level sending unit 12-31
- 27 – hour meter 12-33
- 26 – fuel gauge 12-32
- test procedures, electric vehicle**
 - 1 – batteries/voltage check 21-10
 - 2 – onboard computer solenoid lockout circuit 21-11
 - 3 – solenoid activating coil 21-12
 - 3 – solenoid diode 21-12
 - 4 – MCOR 21-12
 - 5 – motor, A1 and A2 voltage 21-14
 - 6 – Tow/Run switch 21-15
 - 7 – battery pack voltage (under load) 21-15
 - 8 – key switch 21-16
 - 8 – MCOR limit switch 21-16
 - 9 – 16-pin connector 21-18
 - 10 – onboard computer SCR 21-28
 - 11 – OBC gray wire and fuse 21-28
 - 12 – charger receptacle 21-28
 - 13 – speed sensor, motor 21-29
 - 14 – solenoid 21-30
 - 15 – Forward/Reverse rocker switch 21-30
 - 16 – reverse buzzer 21-31
 - 17 – OBC, rebooting 21-32
 - 18 – battery warning light 21-32
- test procedures, gasoline vehicle**
 - battery 11-9, 11-31
 - diode 11-18
 - engine kill circuit 11-29
 - fuel gauge 11-33
 - fuel level sending unit 11-32
 - fuse 11-11
 - ground cables 11-12
 - headlight 11-37, 12-35
 - headlight diode 11-37, 12-35
 - headlight switch 11-36, 12-34
 - hour meter 11-35
 - ignition coil 11-23
 - ignition test 11-22
 - key switch
 - engine kill circuit 11-28
 - starter circuit 11-13
 - lockout cam 11-31
 - lockout cam limit switch 11-15
 - low oil warning light 11-31
 - oil level sensor 11-30
 - reverse buzzer 11-30
 - reverse buzzer limit switch 11-30
 - RPM limiter 11-23
 - solenoid 11-15
 - starter/generator 11-17, 11-20
 - voltage regulator 11-20
 - wire continuity 11-18
- test procedures, index of** 11-8
- test procedures, IQDM**
 - 1 – handset cord 22-17
 - 2 – handset cord adaptor 22-18
 - 3 – IQDM jacks 22-18
- test procedures, motor**
 - 1 – internal short circuits 26-1, 27-1
 - 2 – armature circuit open 26-2, 27-2
 - 3 – field circuit open 26-2, 27-2
 - armature ground test 26-5, 27-7
- testing**
 - armature ground test (starter/generator) 14-7
 - spark plug 15-2
 - starter/generator
 - armature ground test 13-7
- tie rod and drag link**
 - installation 7-12
 - removal 7-12
- tire**
 - installation 8-3
 - removal 8-1
 - repair 8-2
- toe-in**
 - adjustment 7-14
- tools**
 - see service tools
- torque converter**
 - troubleshooting 20-1
- Tow/Run switch**
 - installation 23-7

removal	23-7	wire continuity testing	11-18, 12-18
testing	21-15	wiring diagram	11-6, 12-6
transaxle, type g			
assembly	28-9		
axle bearing	28-4		
axle shaft			
installation	28-4		
removal	28-1		
disassembly	28-7		
identification	28-1		
inspection	28-7		
installation	28-10		
lubrication	28-1		
oil seal			
installation	28-4		
removal	28-1		
removal	28-5		
troubleshooting	21-2		
battery troubleshooting examples	24-7		
communication display module (CDM)	21-35		
IQDM and IQDM-P handset	22-16		
torque converter	20-1		
troubleshooting guide 1	21-5		
troubleshooting guide 2	21-8		
vehicle troubleshooting guide	12-1		
U			
unitized transaxle			
installation	18-13, 19-14		
lubrication	18-2, 19-2		
removal	18-6, 19-6		
service	18-1, 19-1		
V			
voltage regulator			
installation	14-12		
removal	14-11		
testing	11-20, 12-18		
W			
walk away braking	21-1		
WARNING			
definition of	1-1		
water level			
see batteries, electrolyte level			
wheel			
installation	8-1		
removal	8-1		
see <i>also</i> tire			
wheel, steering			
see steering wheel			



Club Car, Inc.
P.O. Box 204658
Augusta, GA 30917-4658
USA

Web www.clubcar.com
Phone 1.706.863.3000
1.800.ClubCar
Int'l +1 706.863.3000
Fax 1.706.863.5808