

# **2020 Café Express Maintenance and Service Manual**



**Gasoline Vehicle with Kohler ECH440 Engine**

Manual Number 86753090008  
Edition Code A



## FOREWORD

---

Club Car vehicles are designed and built to provide the ultimate in performance efficiency; however, proper maintenance and repair are essential for achieving maximum service life and continued safe and reliable operation.

This manual provides detailed information for the maintenance and repair of the 2019 Café Express vehicle, and should be thoroughly reviewed prior to servicing the vehicle. The procedures provided must be properly implemented, and the DANGER, WARNING, and CAUTION statements must be heeded.

This manual was written for the trained technician who already possesses knowledge and skills in electrical and mechanical repair. *If the technician does not have such knowledge and skills, attempted service or repairs to the vehicle may render the vehicle unsafe.* For this reason, Club Car advises that all repairs and/or service be performed by an authorized Club Car distributor/dealer representative or by a Club Car factory-trained technician.

It is the policy of Club Car to assist its distributors and dealers in continually updating their service knowledge and facilities so they can provide prompt and efficient service for vehicle owners. Regional technical representatives, vehicle service seminars, periodic service bulletins, maintenance and service manuals, and other service publications also represent Club Car's continuing commitment to customer support.

Club Car offers a full line of training and continuing education classes for technicians who want to learn more about our products. For more information, contact your local dealer or Club Car's Technical Services department for a list of upcoming classes.

This manual covers all aspects of typical vehicle service; however, unique situations sometimes occur when servicing a vehicle. If it appears that a service question is not answered in this manual, please contact your nearest authorized Club Car dealer or distributor for assistance.

To find your local authorized Club Car dealer, visit [www.clubcardealer.com](http://www.clubcardealer.com), call 1-800-ClubCar (258-2227), or scan this Quick Response (QR) code to be taken to the Club Car dealer locator. Refer to Figure 1. Download a QR code reader such as RedLaser or Barcode Scanner to your cell phone or tablet.

If you would prefer to write to us, direct your letter to: Club Car LLC, Attention: Marketing Services, P.O. Box 204658, Augusta, Georgia 30917-4658 USA.

### Dealer Locator QR Code



Copyright © 2019

*Club Car is a registered trademark of Club Car, LLC*

This manual effective June, 2019

# FOREWORD

---

## TECHNICAL PUBLICATION CUSTOMER SATISFACTION ONLINE SURVEY

Let your voice be heard!

Please participate in the Technical Publication customer satisfaction online survey. This survey takes less than five minutes to complete and your responses will help examine current performance and identify areas for future improvement.

Our top priority is to provide timely, accurate, and user friendly manuals.

The online survey can be found at <http://bit.ly/1w9uFMh> or using the QR Code below.

Online Survey QR Code



## **⚠ WARNING**

---

- **Read Safety on page 1-1 before attempting any service on the vehicle.**
- **Before servicing vehicle, read complete section(s) and any referenced information that may be relevant to the service or repair to be performed.**

**NOTE:** *This manual represents the most current information at the time of publication. Club Car is continually working to further improve its vehicles and other products. These improvements may affect servicing procedures. Any modification and/or significant change in specifications or procedures will be forwarded to all Club Car dealers and will, when applicable, appear in future editions of this manual.*

*Club Car reserves the right to change specifications and designs at any time without notice and without the obligation of making changes to units previously sold.*

*There are no warranties expressed or implied in this manual. See the limited warranty found in the vehicle Owner's Manual.*

# CONTENTS

---

<b>SECTION 1 — Safety</b> .....	1-1
<hr/>	
Safety Details .....	1-1
Personal Safety .....	1-1
Machine Safety.....	1-1
Information.....	1-1
General Warnings.....	1-1
Disabling the Vehicle.....	1-3
Disconnecting the Battery-Gasoline Vehicles .....	1-3
Connecting the Battery-Gasoline Vehicles .....	1-3
Recycling Lead-Acid Batteries .....	1-4
International safety symbols on batteries.....	1-5
<b>SECTION 2 — Vehicle Specifications</b> .....	2-1
<hr/>	
Vehicle Specifications .....	2-1
<b>SECTION 3 — General Information</b> .....	3-1
<hr/>	
Model Identification.....	3-1
Storage.....	3-2
Preparing the Gasoline Vehicle for Extended Storage .....	3-3
Returning the Stored Gasoline Vehicle to Service .....	3-3
<b>SECTION 4 — Body and Trim</b> .....	4-1
<hr/>	
Cleaning the Vehicle .....	4-1
Seat Cleaning.....	4-1
Front Body Repair .....	4-2
Light Scratches.....	4-2
Abrasions and Haze .....	4-2
Large Scratches and Abrasions .....	4-2
Front Body .....	4-2
Brushguard Removal .....	4-2
Brushguard Installation .....	4-3
Cowl Removal .....	4-4
Cowl Installation .....	4-4
Grille Removal.....	4-5
Grille Installation.....	4-6
Front Bumper and Side Fender Removal .....	4-8
Front Bumper and Side Fender Installation.....	4-8
Instrument Panel Removal .....	4-9
Instrument Panel Installation .....	4-9
Dash Removal.....	4-10
Dash Installation.....	4-10
Tilt Bed .....	4-12
Tilt Bed Removal .....	4-12
Tilt Bed Installation .....	4-12
Bed Latch Assembly Removal .....	4-14
Bed Latch Assembly Installation .....	4-14
Rear Fenders and Tailskirt.....	4-16
Rear Fender and Tailskirt Removal .....	4-16
Rear Fender and Tailskirt Installation .....	4-16
Electric Bed Lift .....	4-18
Electric Bed Lift Removal .....	4-19
Electric Bed Lift Installation .....	4-19
Floor Mat .....	4-20
Floor Mat Removal .....	4-20
Floor Mat Installation.....	4-20

---

<b>SECTION 5 — Accelerator and Brake Pedal Group</b> .....	5-1
<hr/>	
Brake Pedal and Park Brake .....	5-1
Brake Pedal Removal (Gas and Electric Vehicles) .....	5-1
Brake Pedal Installation (Gas and Electric Vehicles).....	5-1
Park Brake Removal .....	5-4
Park Brake Installation .....	5-4
Accelerator Pedal .....	5-5
Accelerator Pedal Removal – Gasoline Vehicles .....	5-5
Accelerator Pedal Installation – Gasoline Vehicles .....	5-6
Pedal Group Adjustment .....	5-7
<b>SECTION 6 — Wheel Brake Assemblies</b> .....	6-1
<hr/>	
General Information .....	6-1
Brake Shoe Removal .....	6-1
Brake Assembly Cleaning .....	6-3
Brake Shoe Installation .....	6-6
Brake Adjustment .....	6-7
Brake Cluster Adjustment .....	6-7
Brake Cable Equalization .....	6-10
Final Brake Cluster Adjustment .....	6-11
Test Drive Vehicle .....	6-11
Brake Cluster Removal and Installation .....	6-12
Front Brake Cluster Removal .....	6-12
Front Brake Cluster Installation .....	6-12
Rear Brake Cluster Removal .....	6-14
Rear Brake Cluster Installation .....	6-14
Front Brake Cables .....	6-15
Front Brake Cable Removal .....	6-16
Front Brake Cable Installation .....	6-16
Rear Brake Cables .....	6-17
Rear Brake Cable Removal .....	6-17
Rear Brake Cable Installation .....	6-17
<b>SECTION 7 — Steering and Front Suspension</b> .....	7-1
<hr/>	
General Information .....	7-1
Steering Wheel .....	7-1
Steering Wheel Removal .....	7-1
Steering Wheel Installation .....	7-2
Steering Column .....	7-3
Steering Column Removal .....	7-4
Steering Column Disassembly .....	7-4
Steering Column Assembly .....	7-4
Steering Column Installation .....	7-5
Steering Adjustment .....	7-6
Rack and Pinion .....	7-7
Rack and Pinion Inspection .....	7-7
Rack and Pinion Removal – Maintenance-Free Ball Joints .....	7-7
Rack and Pinion Disassembly .....	7-8
Rack and Pinion Assembly .....	7-10
Rack and Pinion Installation – Maintenance-Free Ball Joints .....	7-13
Tie Rod and Drag Link .....	7-14
Tie Rod and Drag Link Removal – Maintenance-Free Ball Joints .....	7-14
Tie Rod and Drag Link Installation – Maintenance-Free Ball Joints .....	7-14
Front Suspension .....	7-15
Lubrication .....	7-15
Wheel Alignment .....	7-15
Front Suspension Components .....	7-17
Leaf Spring Removal .....	7-17
Leaf Spring Installation .....	7-17
Kingpin and Steering Spindle Removal – Maintenance-Free Ball Joints .....	7-17
Kingpin and Steering Spindle Installation – Maintenance-Free Ball Joints .....	7-20

Delta A-Plate Removal .....	7-20
Delta A-Plate Installation .....	7-20
Shock Absorber Removal .....	7-20
Shock Absorber Installation .....	7-20
Front Wheel Bearings and Hubs .....	7-21
Front Wheel Free Play Inspection .....	7-21
Front Hub and Wheel Bearings Removal .....	7-21
Front Hub and Wheel Bearings Installation .....	7-22
<b>SECTION 8 — Wheels and Tires .....</b>	<b>8-1</b>
<hr/>	
General Information .....	8-1
Wheels .....	8-1
Wheel Removal .....	8-1
Wheel Installation .....	8-1
Tires .....	8-2
Tire Removal .....	8-2
Tire Repair .....	8-2
Tire Installation .....	8-3
<b>SECTION 9 — Rear Suspension .....</b>	<b>9-1</b>
<hr/>	
General Information .....	9-1
Shock Absorbers .....	9-1
Shock Absorber Inspection and Removal .....	9-1
Shock Absorber Installation .....	9-1
Multi-Leaf Springs .....	9-2
Multi-Leaf Spring Removal .....	9-2
Multi-Leaf Spring Installation .....	9-3
<b>SECTION 10 — Periodic Maintenance .....</b>	<b>10-1</b>
<hr/>	
General Information .....	10-1
Pre-Operation and Daily Safety Checklist .....	10-1
Performance Inspection .....	10-2
Maintenance .....	10-2
Periodic Service Schedule .....	10-3
Periodic Lubrication Schedule .....	10-6
Air Filter .....	10-7
Air Filter Removal .....	10-7
Air Filter Installation .....	10-7
Engine Oil .....	10-8
Engine Oil Viscosity .....	10-8
Engine Oil Level Inspection .....	10-8
Engine Oil Replacement .....	10-9
Add Engine Oil .....	10-12
Refuel .....	10-13
Lift The Vehicle .....	10-14
Lift The Front Of The Vehicle .....	10-14
Lift The Rear Of The Vehicle .....	10-15
Lower The Front Of The Vehicle .....	10-16
Lower The Rear Of The Vehicle .....	10-17
Spark Plug .....	10-18
Spark Plug Removal .....	10-18
Spark Plug Inspection .....	10-19
Spark Plug Gap .....	10-19
Spark Plug Installation .....	10-20
Valve Clearance Check and Adjustment .....	10-20
<b>SECTION 11 — Troubleshooting and Electrical System .....</b>	<b>11-1</b>
<hr/>	
General Information .....	11-1
Accessories .....	11-1
Low Oil Warning Light .....	11-1

Malfunction Indicator Light.....	11-2
Ground Locations .....	11-2
Features of the Electronic Fuel Injection (EFI) System .....	11-2
Troubleshooting Guide .....	11-2
Gasoline Powertrain .....	11-3
Electrical System .....	11-5
Test Procedures .....	11-6
Testing Basics .....	11-6
<b>SECTION 12 — Electrical Components .....</b>	<b>12-1</b>
<hr/>	
General Information .....	12-1
Starter/Generator.....	12-1
Starter/Generator Removal .....	12-1
Disassembly of the Starter/Generator to Service the Brushes .....	12-2
Brush Inspection and Replacement.....	12-3
Brush Spring Inspection and Replacement.....	12-3
Starter/Generator Assembly .....	12-4
Disassembly of the Starter/Generator to Service the Armature/Commutator .....	12-5
Bearing Cleaning and Inspection .....	12-6
Bearing Removal .....	12-7
Field Coil Assembly .....	12-7
Visual Inspection of Armature .....	12-7
Commutator Cleaning and Inspection .....	12-8
Armature Ground Test.....	12-9
Visual Inspection of Field Coils .....	12-10
Starter/Generator Rework .....	12-10
Starter/Generator Assembly .....	12-10
Starter/Generator Installation.....	12-13
Belt Tension Inspection For EFI Engines .....	12-14
Belt Tension Adjustment for EFI Engines.....	12-15
Belt Tension Tool Modification.....	12-18
Voltage Regulator.....	12-19
Voltage Regulator Removal .....	12-19
Voltage Regulator Installation .....	12-19
Key Switch .....	12-20
Key Switch Removal .....	12-20
Key Switch Installation .....	12-21
Maintenance/Operate Switch.....	12-21
Maintenance/Operate Switch Removal.....	12-21
Maintenance/Operate Switch Installation.....	12-22
Neutral Lockout Limit Switch .....	12-23
Neutral Lockout Limit Switch Removal .....	12-23
Neutral Lockout Limit Switch Installation.....	12-24
Solenoid.....	12-26
Solenoid Removal .....	12-26
Solenoid Installation.....	12-27
Fuse .....	12-28
Fuse Removal .....	12-28
Fuse Installation .....	12-29
Accelerator Pedal Limit Switch .....	12-30
Accelerator Pedal Limit Switch Removal .....	12-30
Accelerator Pedal Limit Switch Installation.....	12-30
Kill Limit Switch .....	12-31
Kill Limit Switch Removal .....	12-31
Kill Limit Switch Installation .....	12-31
Reverse Warning Buzzer.....	12-32
Reverse Warning Buzzer Removal .....	12-32
Reverse Warning Buzzer Installation.....	12-32
Reverse Buzzer Limit Switch .....	12-33
Reverse Buzzer Limit Switch Removal .....	12-33
Reverse Buzzer Limit Switch Installation .....	12-33
Low Oil Warning Light .....	12-34
Low Oil Warning Light Removal.....	12-34



Low Oil Warning Light Installation .....	12-34
Malfunction Indicator Light.....	12-35
Malfunction Indicator Light Removal.....	12-35
Malfunction Indicator Light Installation.....	12-35
Fuel Gauge/Hour Meter .....	12-35
General Information .....	12-35
Fuel Gauge/Hour Meter Removal .....	12-36
Fuel Gauge/Hour Meter Installation.....	12-36
Fuel Level Sending Unit.....	12-36
Voltage Limiter .....	12-37
Voltage Limiter Removal .....	12-37
Voltage Limiter Installation.....	12-37
Headlight Switch.....	12-38
Headlight Switch Removal.....	12-38
Headlight Switch installation .....	12-38
Headlights.....	12-39
Headlight Bezel Removal .....	12-39
Headlight Bezel Installation .....	12-39
Halogen Headlight Bulb Removal .....	12-40
Halogen Headlight Bulb Installation.....	12-40
Halogen Headlight Lens Removal.....	12-41
Halogen Headlight Lens Installation .....	12-41
LED Headlight Removal .....	12-42
LED Headlight Installation .....	12-42
Battery .....	12-42
General Information .....	12-43
Preventive Maintenance.....	12-43
Self-Discharge.....	12-43
Vibration Damage .....	12-44
Battery Removal.....	12-44
Charging the Battery .....	12-44
Battery Installation .....	12-44
Battery Storage .....	12-45
Charging a Dead Battery.....	12-45
Oxygen Sensor.....	12-46
Oxygen Sensor Removal .....	12-46
Oxygen Sensor Installation.....	12-46
Ground Cables .....	12-46
<b>SECTION 13 — Engine.....</b>	<b>13-1</b>
<hr/>	
General Information .....	13-1
Before Servicing .....	13-1
Engine Removal.....	13-2
Engine Installation .....	13-5
Snubber.....	13-8
Snubber Removal.....	13-8
Snubber Installation .....	13-8
<b>SECTION 14 — Fuel System.....</b>	<b>14-1</b>
<hr/>	
General Information .....	14-1
EFI System Features/Specifications.....	14-1
Engine Control Linkages .....	14-1
General Information .....	14-2
Ground Speed.....	14-2
Accelerator Rod.....	14-2
Governor Cable .....	14-5
Accelerator Cable .....	14-7
Closed Throttle or Idle Adjustment .....	14-10
How to Measure Ground Speed.....	14-10
Engine RPM Adjustment .....	14-10
Air Intake System .....	14-11
Air Cleaner Removal.....	14-12

Air Cleaner Installation .....	14-12
Relieving Fuel Pressure .....	14-13
To Relieve Fuel Pressure .....	14-13
Fuel Line .....	14-13
Fuel Line Removal .....	14-14
Fuel Line Installation .....	14-15
Fuel Pump Module .....	14-17
General Information .....	14-17
Fuel Pump Module Removal .....	14-18
Fuel Pump Module Installation .....	14-19
Fuel Tank .....	14-20
General Information .....	14-20
Fuel Tank Removal .....	14-21
Fuel Tank Disposal .....	14-22
Fuel Tank Storage .....	14-22
Fuel Tank Installation .....	14-23
Fuel Filter .....	14-24
General Information .....	14-24
Fuel Filter Removal .....	14-24
Fuel Filter Installation .....	14-24
<b>SECTION 15 — Exhaust System .....</b>	<b>15-1</b>
<hr/>	
Muffler .....	15-1
Muffler Removal .....	15-1
Muffler Installation .....	15-2
<b>SECTION 16 — Clutches .....</b>	<b>16-1</b>
<hr/>	
General Information .....	16-1
Troubleshooting .....	16-1
Drive Belt .....	16-3
Drive Belt Removal .....	16-3
Drive Belt Installation .....	16-3
Drive Clutch .....	16-4
Drive Clutch Removal .....	16-5
Drive Clutch Cleaning and Inspection .....	16-6
Drive Clutch Disassembly .....	16-7
Inspection of Drive Clutch Parts .....	16-9
Drive Clutch Assembly .....	16-10
Drive Clutch Installation .....	16-11
Driven Clutch .....	16-12
Driven Clutch Removal .....	16-13
Driven Clutch Disassembly .....	16-13
Driven Clutch Inspection .....	16-16
Driven Clutch Assembly .....	16-16
Driven Clutch Installation .....	16-19
<b>SECTION 17 — Transaxle .....</b>	<b>17-1</b>
<hr/>	
General Information .....	17-1
Forward/Neutral/Reverse control (FNR) .....	17-1
Maintenance/Operate Switch .....	17-1
Governor System .....	17-2
Transaxle Service .....	17-2
Lubrication .....	17-2
Tools Required For This Section .....	17-3
Rear Hubs .....	17-4
Rear Hub Removal .....	17-4
Rear Hub Installation .....	17-4
Axle Tubes, Axle Shafts and Wheel Bearings .....	17-6
Axle Tube and Axle Shaft Removal .....	17-6
Axle Tube and Axle Shaft Installation .....	17-7
Rear Wheel Bearing Removal .....	17-7

Rear Wheel Bearing Installation.....	17-7
Axle Shaft Oil Seal Removal.....	17-7
Axle Shaft Oil Seal Installation.....	17-8
Transaxle Removal.....	17-9
Transaxle Installation.....	17-13
Shifter Cable.....	17-13
Shifter Cable Removal.....	17-13
Shifter Cable Installation.....	17-14
Shifter Cable Adjustment.....	17-14
<b>SECTION 18 — Kohler Engine Service Manual.....</b>	<b>18-1</b>
<hr/>	
<b>SECTION 19 — Refreshment Unit.....</b>	<b>19-1</b>
<hr/>	
General Information.....	19-1
Refreshment Center Compartments.....	19-1
Cleaning.....	19-1
Interior Aluminum Surfaces.....	19-1
Exterior Aluminum Surfaces.....	19-1
Drains.....	19-2
Refreshment Center Doors.....	19-2
Canopy Cover.....	19-2
Windshield.....	19-2
Canopy.....	19-2
Canopy Removal.....	19-3
Canopy Installation.....	19-4
Canopy Frame Removal.....	19-4
Canopy Frame Installation.....	19-4
Unit Maintenance and Repairs.....	19-5
Trash Drawer.....	19-5
Slide Doors.....	19-6
Coffee Doors.....	19-7
Containers.....	19-8
Cup Holder.....	19-8
<b>SECTION 20 — Wiring Diagrams.....</b>	<b>20-1</b>
<hr/>	
General Information.....	20-1
Pedal-Start Connector Pinouts.....	20-2
Pedal-Start Main Harness Connector Pinouts.....	20-2
Key-Start Connector Pinouts.....	20-7
Key-Start Main Harness Connector Pinouts.....	20-7
Engine Harness Wiring Diagram Table.....	20-12
Index.....	Index-1
<hr/>	



---

## SAFETY DETAILS

---

To ensure the safety of those servicing Club Car vehicles, and to protect the vehicles from possible damage resulting from improper service or maintenance, the procedures in this manual must be followed.

It is important to note that throughout this manual there are statements labeled DANGER, WARNING, or CAUTION. These special statements relate to specific safety issues, and must be read, understood, and heeded before proceeding with procedures. There are statements labeled NOTE, which provide other essential service or maintenance information.

### PERSONAL SAFETY

#### **DANGER**

- A DANGER indicates an immediate hazard that will result in severe personal injury or death. The color associated with Danger is RED.

#### **WARNING**

- A WARNING indicates an immediate hazard that could result in severe personal injury or death. The color associated with Warning is ORANGE.

#### **CAUTION**

- A CAUTION with the safety alert symbol indicates a hazard or unsafe practice that could result in minor personal injury. The color associated with Caution is YELLOW.

### MACHINE SAFETY

#### **CAUTION**

- A CAUTION without the safety alert symbol indicates a potentially hazardous situation that could result in property damage.

A CAUTION, without the safety alert symbol, is intended for machine and property safety. It is used throughout this manual followed by specific instructions to prevent machine or property damage. Failure to follow these CAUTION messages could result in machine or property damage.

### INFORMATION

*NOTE: Instructions that clarify steps, procedures, or other information in this manual.*

## GENERAL WARNINGS

---

The following safety statements must be heeded whenever the vehicle is being operated, repaired, or serviced. Other specific safety statements appear throughout this manual and on the vehicle.

## **DANGER**

- **Battery – Explosive gases! Do not smoke. Keep sparks and flames away from the vehicle and service area. Ventilate when charging or operating vehicle in an enclosed area. Wear a full face shield and rubber gloves when working on or near batteries.**
- **Gasoline – Flammable! Explosive! Do not smoke. Keep sparks and flames away from the vehicle and service area. Service only in a well-ventilated area.**
- **Do not operate engine in an enclosed area without proper ventilation. The engine produces carbon monoxide, which is an odorless, deadly poison.**
- **The vehicle will not provide protection from lightning, flying objects, or other storm-related hazards. If caught in a storm while driving a Club Car vehicle, exit the vehicle and seek shelter in accordance with applicable safety guidelines for your location.**

## **WARNING**

- **Follow the procedures exactly as stated in this manual, and heed all DANGER, WARNING, and CAUTION statements in this manual as well as those on the vehicle and battery charger.**
- **Do not leave children unattended in vehicle at any time.**
- **Prior to leaving the vehicle unattended or servicing the vehicle, set the park brake, place the Forward/Reverse handle or switch in the NEUTRAL position, turn the key switch to the OFF position, and remove the key. Chock the wheels when servicing the vehicle.**
- **Improper use of the vehicle or failure to properly maintain it can result in decreased vehicle performance, serious personal injury, or death.**
- **Any modification or change to the vehicle that affects the electrical system, stability or handling of the vehicle, or increases maximum vehicle speed beyond factory specifications, can result in serious personal injury or death.**
- **Check the vehicle for proper location of all vehicle safety and operation decals and make sure they are in place and are easy to read.**
- **For vehicles with cargo beds, remove all cargo (including accessories) before raising the bed or servicing the vehicle. If the vehicle is equipped with a prop rod, ensure that it is securely engaged while bed is raised. Do not close bed until all persons are clear of cargo bed area. Keep hands clear of all crush areas. Do not drop cargo bed; lower gently and keep entire body clear. Failure to heed this warning can result in serious personal injury or death.**
- **Only trained technicians should service or repair the vehicle. Anyone doing even simple repairs or service should have knowledge and experience in electrical and mechanical repair. The appropriate instructions must be used when performing maintenance, service, or accessory installation.**
- **To avoid unintentionally starting the vehicle, disconnect the battery and spark plug wire. See Disconnecting the Battery-Gasoline Vehicles on page 1-3.**
- **Frame ground – Do not allow tools or other metal objects to contact frame when disconnecting battery cables or other electrical wiring. Do not allow a positive wire to touch the vehicle frame, engine, or any other metal component.**
- **Wear safety glasses or approved eye protection when servicing the vehicle. Wear a full face shield and rubber gloves when working on or near batteries.**
- **Do not wear loose clothing or jewelry such as rings, watches, chains, etc., when servicing the vehicle.**

WARNING CONTINUED ON NEXT PAGE

## **⚠ WARNING**

- Use insulated tools when working near batteries or electrical connections. Use extreme caution to avoid shorting of components or wiring.

## **DISABLING THE VEHICLE**

1. Engage park brake to lock wheels.
2. Turn the key switch OFF and remove the key.
3. Place the Forward/Reverse control in the NEUTRAL position.
4. In addition, chock the wheels if servicing or repairing the vehicle.

## **DISCONNECTING THE BATTERY-GASOLINE VEHICLES**

1. Disable the vehicle. **See Disabling the Vehicle on page 1-3.**
2. Remove positive terminal cover.
3. Disconnect the battery cables, negative (–) cable first, as shown (**Figure 1-1**).
4. Disconnect the spark plug wire(s) from the spark plug(s).

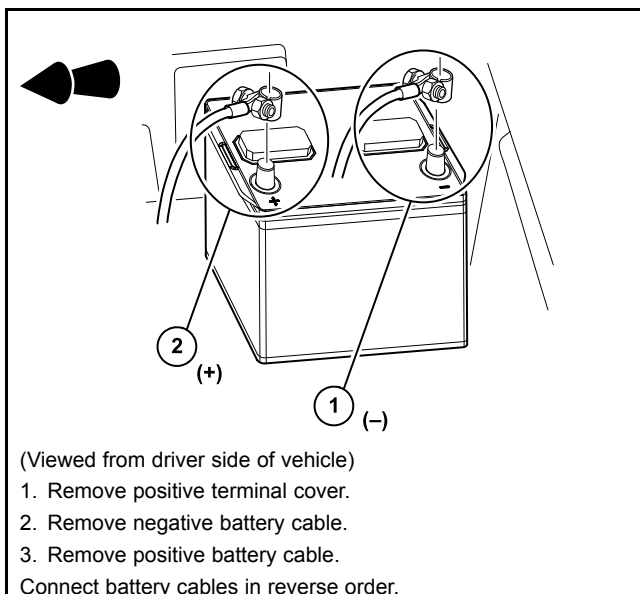

3167

**Figure 1-1 Top-Post Battery- Battery Cable Removal-Gasoline Vehicles**

## **CONNECTING THE BATTERY-GASOLINE VEHICLES**

1. Connect the battery cables, positive (+) cable first.
2. Tighten battery terminals to 41 in·lb (4.3 N·m).
3. Coat terminals with Battery Terminal Protector Spray to minimize corrosion.
4. Attach positive terminal cover.
5. Connect the spark plug wire(s) to the spark plug(s).

## RECYCLING LEAD-ACID BATTERIES

### **⚠ WARNING**

- **Lead-acid batteries contain lead (Pb), other metals, acids and other compounds. If improperly handled, they can contaminate both water and soil, causing environmental damage and personal injury.**

Lead-acid batteries are identified by the symbol shown below and should be properly recycled (**Figure 1-2**). They cannot be disposed as municipal waste and must be collected separately. Responsibility for environmental protection must be shared, not only by the manufacturers of the batteries, but by people who use the batteries as well. Please contact your nearest Club Car dealer or distributor for information on how to properly recycle your batteries.

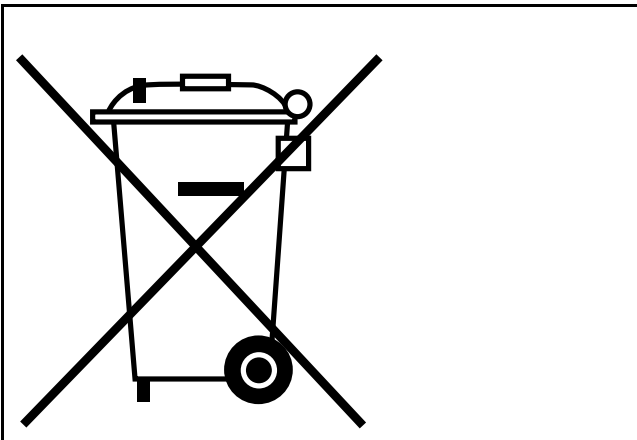

1403

**Figure 1-2 Dispose of Lead-acid Batteries Properly**



**INTERNATIONAL SAFETY SYMBOLS ON BATTERIES**

Anyone using, repairing, or servicing the vehicle must understand and heed the safety symbols on the vehicle battery or batteries.

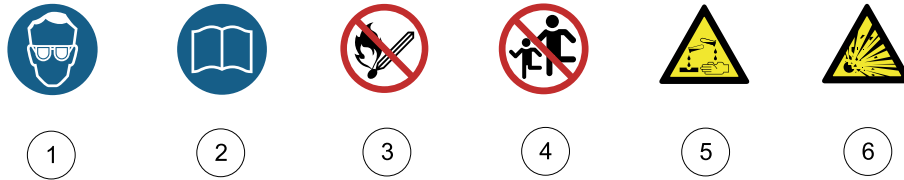

1. Shield eyes.	3. No smoking, no open flames, no sparks.	5. Battery acid hazard.
2. Read and follow operating instructions.	4. Keep away from children.	6. Explosive gas hazard.
Refer to General Warnings for more information.		

1642

**Figure 1-3 International Safety Symbols on Batteries**

Pagination Page

## SECTION 2 — VEHICLE SPECIFICATIONS

2

### VEHICLE SPECIFICATIONS

**NOTE:** Engine horsepower and torque specifications are provided by the engine manufacturer. Actual horsepower and torque in use may differ and are dependent on environmental conditions as well as maintenance condition of the engine.

SPECIFICATIONS	CAFE EXPRESS
<b>POWER SOURCE</b>	<b>GASOLINE</b>
<b>Engine:</b> 4 cycle, OHC, 404 cc, 14.0 Horsepower (10.4 kW) rated engine @ 3600 RPM (per SAE J 1940), single cylinder, air cooled, with splash lubrication system	•
<b>Fuel system:</b> Electronic fuel injection (EFI), high-pressure rotary fuel pump with 10 micron fuel filter	•
<b>Battery:</b> 12-volt, Top-Post Battery	•
<b>Governor:</b> Automatic ground speed sensing, internally geared in transaxle	•
<b>Ignition:</b> Digital CDI with electronic RPM limiter	•
<b>Transaxle:</b> Precision helical gears, forward/reverse with neutral position (11.47:1 forward; 15.63:1 reverse), with optional limited slip differential	•
<b>Electrical system:</b> 12 volt, 525 CCA, 85 minute reserve capacity	•
<b>Gasoline Vehicle Electrical Charging System:</b> 23 amps at max. RPM.	•
<b>Torque converter:</b> Automatic, variable speed, dry type	•
<b>STEERING/SUSPENSION/BRAKES</b>	
<b>Steering:</b> Self-adjusting rack and pinion	•
<b>Suspension:</b> Independent leaf spring with dual hydraulic shocks	•
<b>Brakes:</b> Mechanical brake cable system to manually-adjusted drum brakes on all four wheels. Park brake is automatically released. Multi-latch ratchet and pawl.	•
<b>BODY/CHASSIS</b>	
<b>Frame/chassis:</b> Twin I-Beam welded aluminum	•
<b>Side and rear body:</b> Aluminum	•
<b>Front body:</b> ArmorFlex®	•
<b>Front body finish:</b> Automotive-grade paint with clear-coat finish	•
<b>Tires:</b> 20 x 10 - 10 tubeless, 6-ply rated load range front and rear	•
<b>DIMENSIONS/WEIGHT</b>	
<b>Overall length:</b> Standard configuration Add for Heavy-Duty Bumper: 1.8 in (4.5 cm)	125.5 in (318.7 cm)
<b>Overall width</b> with mirrors:	51.4 in (130.5 cm) 62.6 in (159.0 cm)
<b>Overall height:</b> at steering wheel	47.1 in (119.6 cm)
<b>Overall height:</b> with canopy	70.7 in (179.5 cm)
<b>Wheelbase</b>	78.1 in (198.3 cm)
<b>Ground clearance</b>	5.2 in (13.2 cm)
<b>Front wheel tread</b>	36.6 in (92.9 cm)

SPECIFICATIONS	CAFE EXPRESS
<b>POWER SOURCE</b>	<b>GASOLINE</b>
<b>Rear wheel tread</b>	39.5 in (100.3 cm)
<b>Weight:</b> Standard gasoline vehicle with Cafe Express unit (dry fuel tank) Curb weight:	1147 lb (520.2 kg) 1175 lb (532.9 kg)
<b>Maximum forward speed</b>	12 to 14 mph (19 to 23 km/h)
<b>Outside clearance circle</b> (diameter)	248.5 in (631.19 cm)
<b>Turning radius</b> (per SAE J 695)	119 in (302.2 cm)
<b>Intersecting aisle clearance</b>	52.5 in (133.3 cm)
<b>Floorboard height</b>	7.2 in (18.2 cm)
<b>Load bed size:</b> Cafe Express unit dimensions	56.7 x 50.5 x 41.5 in (144 x 128.2 x 105.4 cm)
<b>Vehicle rated capacity:</b> Level surface only	850 lb (385.6 kg)
<b>Standard seating capacity:</b> (persons)	2
<b>LIQUID CAPACITIES</b>	
<b>Engine crankcase</b>	40.5 fl-oz (1.2 L)
<b>Transaxle</b>	67.6 fl-oz (2 L)
<b>Fuel tank</b>	4.6 gallons (17.4 L)
<b>TIRE PRESSURE</b>	
<b>Front and rear</b>	28 to 32 psig (193 to 221 kPa)
<b>NOISE AND VIBRATION</b>	
<b>Drive-by noise level to operator</b> Test method: EN 12053:2001	71.3 dBa Uncertainty: 2 dBa
<b>Vibration at driver's seat</b> Test method: EN 13059:2002	0.6 (m/s <sup>2</sup> ) <sup>2</sup> Uncertainty: 0.18 (m/s <sup>2</sup> ) <sup>2</sup>

### **⚠ DANGER**

- See General Warnings on page 1-1.

### **⚠ WARNING**

- See General Warnings on page 1-1.

Important features unique to the different models covered in this manual are highlighted. Club Car, LLC recommends the owner/operator read and understand this manual and pay special attention to features specific to their vehicle(s).

Refer to the owner's manual provided with the vehicle for information on the following topics:

- Controls and Indicators
- Pre-Operation and Daily Safety Checklist
- Driving Instructions
- Bed Latch
- Prop Rod
- Loading and Unloading
- Towing with a Vehicle
- Transporting on a Trailer
- Subsequent Owner Registration
- Warranties

## MODEL IDENTIFICATION

The serial number of each vehicle is printed on a bar code decal mounted below the center dash panel (Example: CC5819-123456) (**Figure 3-1**).

The two letters (1) at the beginning of the serial number indicate the vehicle model. The following four digits (2) indicate the model year and production week during which the vehicle was built. The six digits (3) following the hyphen represent the unique sequential number assigned to each vehicle built within a given model year. **See following NOTE.**

**NOTE:** Have the vehicle serial number available when ordering parts or making inquiries.

**Build Code:** The build code (4) is a five-digit number that appears on the vehicle serial number decal. The build code exists to enable the user to identify the correct owner's manual for a vehicle. This owner's manual is valid for the build code range indicated on the back cover of this owner's manual.

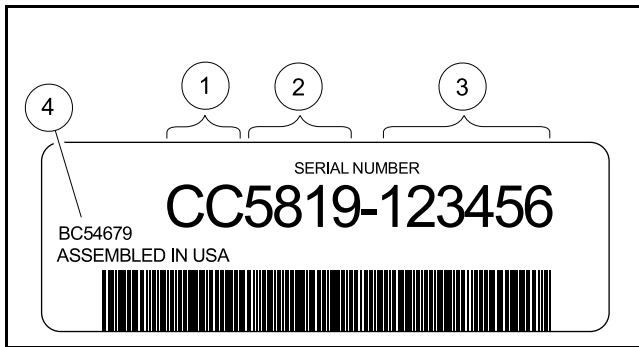

2843

Figure 3-1 Serial Number Decal

## STORAGE

See General Warnings on page 1-1.

### **⚠ DANGER**

- Do not attempt to drain fuel when the engine is hot or while it is running.
- Be sure to clean up any spilled gasoline before operating the vehicle.
- Store fuel in an approved fuel container only. Store in a well-ventilated area away from sparks, open flames, heaters, or heat sources.
- Keep fuel out of the reach of children.
- Do not siphon fuel from the vehicle.

### **⚠ WARNING**

- Only trained technicians should service or repair the vehicle. Anyone doing even simple repairs or service should have knowledge and experience in electrical and mechanical repair. The appropriate instructions must be used when performing maintenance, service, or accessory installation.
- Turn the key switch to the OFF position, remove the key, and leave the Forward/Reverse handle in the NEUTRAL position during storage. This is to prevent unintentionally starting the vehicle or a fire hazard.
- Do not attempt to charge frozen batteries or batteries with bulged cases. Discard the battery. Frozen batteries can explode.

### **⚠ CAUTION**

- Batteries in a low state of charge will freeze at low temperatures.

## PREPARING THE GASOLINE VEHICLE FOR EXTENDED STORAGE

1. Unload the vehicle so that tires are supporting only the weight of the vehicle.
2. Store vehicle in a cool, dry place. This will minimize battery self-discharge. If the battery appears to be weak, have it charged by a trained technician. Use an automotive-type 12-volt battery charger rated at 10 amps or less.
3. Seal the fuel tank.
  - 3.1. Fill fuel tank, and, following manufacturer's directions, add a commercially available fuel stabilizer (such as Sta-Bil®).
  - 3.2. Disconnect fuel vent line from fuel tank vent nipple.
  - 3.3. Plug the fuel tank vent nipple so that it is air tight. We recommend using a slip-on vinyl cap.

**NOTE:** *It is not necessary to drain the fuel line.*

4. Disconnect battery and spark plug wire. **See Disconnecting the Battery-Gasoline Vehicles on page 1-3.**
5. Batteries should be clean and free of corrosion. Wash tops and terminals of batteries with a solution of baking soda and water: use 1 cup (237 mL) baking soda per 1 gallon (3.8 L) of water. Rinse solution off batteries. Do not allow this solution to enter the batteries. Let the terminals dry and then coat them with Battery Terminal Protector Spray.
6. To protect the engine, remove spark plug and pour 0.5 fl-oz (14.2 mL) of SAE 10 weight oil into the engine through the spark plug hole. Rotate engine crankshaft by hand several times and then install the spark plug and tighten it to 20 ft·lb (27 N·m).
7. Adjust tires to recommended tire pressure. **See Vehicle Specifications on page 2-1.**
8. Perform semiannual periodic lubrication. **See Periodic Lubrication Schedule on page 10-6.**
9. Thoroughly clean front body, rear body, seats, cargo bed, engine compartment, and underside of vehicle.
10. Thoroughly clean and wipe dry all storage compartments in the refreshment center.
11. Do not engage the park brake. Chock the wheels to prevent the vehicle from rolling.

## RETURNING THE STORED GASOLINE VEHICLE TO SERVICE

1. Restore fuel system to operation.
  - 1.1. Remove plug from the fuel tank vent .
  - 1.2. Connect vent tube to fuel tank vent.
2. Connect battery and spark plug wire. **See Connecting the Battery-Gasoline Vehicles on page 1-3.**
3. Place the Forward/Reverse handle in the NEUTRAL position and the neutral lockout switch in the MAINTENANCE position. Crank the engine until the engine starts. Turn the engine off and return the neutral lockout switch to the OPERATE position. **See following NOTE.**

**NOTE:** *Due to the oil added to the engine in preparation for storage, engine may smoke excessively for a short time when it is run for the first time after storage.*

4. Adjust tires to recommended tire pressure. **See Vehicle Specifications on page 2-1.**
5. Perform the Pre-Operation and Daily Safety Checklist on page 10-1 and the Performance Inspection on page 10-2.

Pagination Page



### **⚠ DANGER**

- See General Warnings on page 1-1.

### **⚠ WARNING**

- See General Warnings on page 1-1.

## CLEANING THE VEHICLE

---

See General Warnings on page 1-1.

### **CAUTION**

- Do not use detergents or cleaning solvents that contain ammonia, aromatic solvents, or alkali materials on body panels or seats.
- Do not allow battery acid to drip on body panels. Battery acid will cause permanent damage. Wash spilled battery acid from body panels immediately.

These vehicles are equipped with painted TPO front bodies and aluminum only rear bodies with black polypropylene rear fender and tailskirt. The cargo beds are steel with aluminum sheet and Rhino Lining®.

The manufacturer does not recommend any type of pressure washing or steam cleaning. Such a process will expose electrical components to moisture. Moisture entering electrical components can result in water damage and subsequent component failure. Normal residential water pressure is adequate for exterior cleaning.

For regular cleaning, use commercially available automotive cleaning solutions with a sponge or soft cloth. The painted finish is the same paint used in automotive applications. Automotive cleaning/polishing products are available at automotive specialty and hardware stores.

Use non-abrasive wax products. Battery acid, fertilizers, tars, asphalt, creosote, paint, or chewing gum should be removed immediately to prevent possible stains.

## SEAT CLEANING

Clean seats regularly using the following guidelines:

**Light Soiling** – A solution of 10% liquid dish soap and warm water applied with a soft, damp cloth is recommended. A soft bristle brush may be used if necessary. Wipe off any residue with a water dampened cloth. **See following NOTE.**

**NOTE:** *Dispose of waste water properly.*

**Difficult Stains** – Dampen a soft, white cloth with a solution of 10% household bleach (sodium hypochlorite) and 90% water. Rub gently to remove stain, then rinse with a water dampened cloth to remove bleach concentration.

**More Difficult Stains** – Perform previous procedure using full-strength bleach, or allow bleach to puddle on affected area for approximately 30 minutes. Rinse with a water dampened cloth to remove any remaining bleach concentration. **See following CAUTION.**

## CAUTION

- To prevent damage to the vehicle when removing difficult stains or heavy soiling, remove the seat from the vehicle first.

## FRONT BODY REPAIR

See General Warnings on page 1-1.

### LIGHT SCRATCHES

1. Clean entire area to be repaired with clean, clear water.
2. Using 1200 grit sandpaper, water-sand entire area of scratch until original scratch is no longer visible, either with finishing sander or wet sanding block. Be sure that sandpaper is centered on sanding pad. Continue to flush with water while sanding, to increase sandpaper life and keep the sanded surface cool. Wipe repaired area dry and visually inspect to be sure that the original scratch has completely disappeared.
3. Repeat step 2 using 1500 grit sandpaper until all 1200 grit scratches are removed paying close attention to edges.
4. Install a wool cutting pad (3M #5711 or equivalent) on buffer and spread approx 1/2 tsp. (2 mL) of compound (3M #05955 or equivalent). Buff slowly and steadily over small area so as not to heat surface as this may cause warping or melting of plastic. Buff sanded area until all sanding scratches have disappeared. Use as much buffing compound as necessary to achieve this step. If at any time original scratches can be seen, repeat steps 2 and 3 as needed. When all 1500 grit scratches have disappeared, there will be a dull luster over entire area.
5. Install a foam polishing pad (3M #5725 or equivalent) on buffer and repeat step 4 using approx 1/2 tsp. (2 mL) buffing compound (3M #5933 or equivalent). Buff compound off until scratches have disappeared. It may be necessary to apply additional compound to achieve this. The result will be an almost-finished product with a very high luster and very few buffer swirls.
6. Using a clean foam polishing pad (3M #5725 or equivalent) and finish glaze (3M #05937 or equivalent), apply a slightly smaller amount of material than in steps 4 and 5 and buff to desired gloss.
7. Wipe clean with soft, clean cloth. Any dirt on cloth can mar surface.

### ABRASIONS AND HAZE

Abrasions and haze can be greatly minimized by performing steps 5 through 7 above.

### LARGE SCRATCHES AND ABRASIONS

Touch-up is not recommended. Replace the entire body part or have it repaired by a professional paint and body repair shop with experience repairing bodies.

## FRONT BODY

See General Warnings on page 1-1.

### BRUSHGUARD REMOVAL

1. Disconnect the batteries.  
See **Disconnecting the Battery-Gasoline Vehicles** on page 1-3.

2. Remove the bolts (1) (**Figure 4-1, Page 4-3**).
3. Remove the screws (2) and washers (3).
4. Remove the brushguard (4).

## BRUSHGUARD INSTALLATION

1. Position the brushguard (4) onto the vehicle (**Figure 4-1, Page 4-3**).
2. Install the washers (3), screws (2), and bolts (1). Tighten the bolts to 36 ft·lb (49 N·m). Tighten the screws to 25 ft·lb (34 N·m).
3. Connect the batteries.  
**See Connecting the Battery-Gasoline Vehicles on page 1-3.**

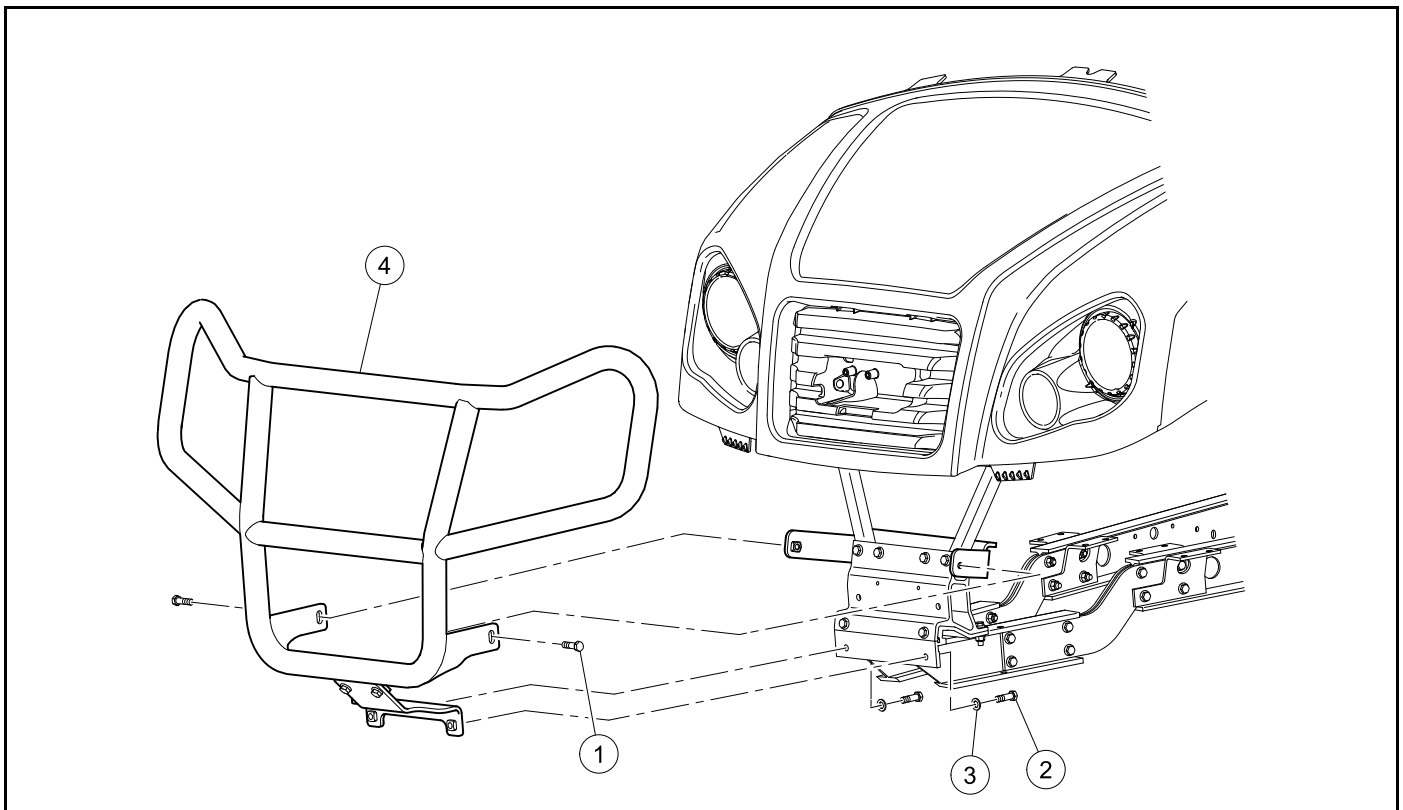

Figure 4-1 Brushguard

## COWL REMOVAL

1. Park vehicle and chock tires.
2. Disconnect the batteries. **See Disconnecting the Battery-Gasoline Vehicles on page 1-3.**
3. The cowl is secured by tabs located behind the front fenders (2), and under the lip of the dash (1) (**Figure 4-2, Page 4-5**).
4. Push down and rearward on front fenders to unsnap cowl in two locations.
5. Slide cowl forward until free, then lift out cowl.

## COWL INSTALLATION

1. Slide bottom edges of cowl into grooves in front fenders.
2. Ensure the three tabs on cowl install under lip of dash (1) (**Figure 4-2, Page 4-5**).
3. Ensure sides of cowl (3) assemble between the two ribs on side of dash.
4. Ensure center tab on cowl assembles beneath the rib in the grille.
5. With fenders disengaged from the front bumper, press down on front fenders, line up cowl tabs and fully engage snap tabs.
6. Ensure front corners of cowl are engaged with front fender (2).
7. Engage the front fenders to the body clips under the front bumper.

**NOTE:** *Ensure that cowl is fully engaged to prevent dislodging during use.*

8. Connect the batteries. **See Connecting the Battery-Gasoline Vehicles on page 1-3.**
9. Remove tire chocks.

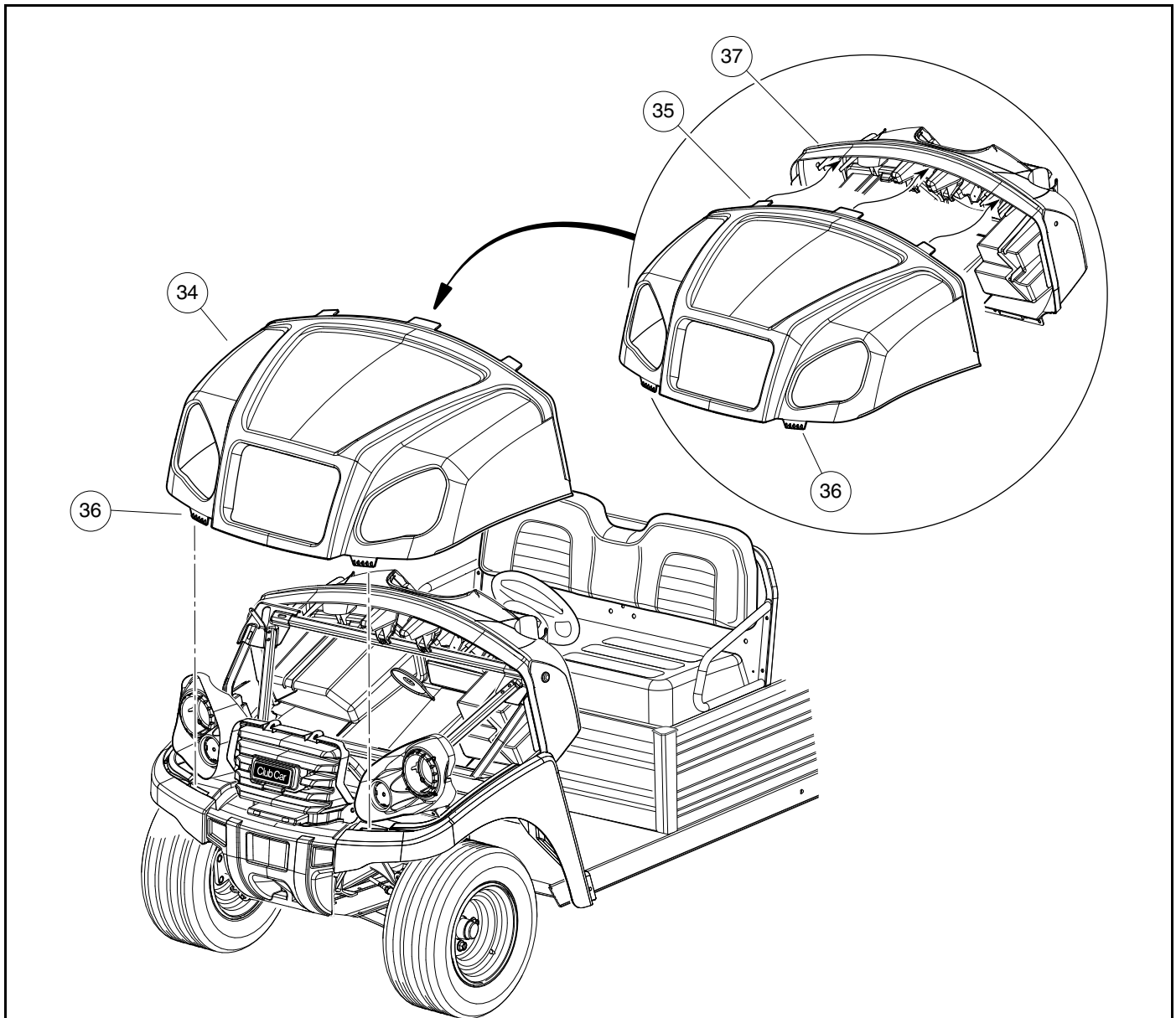

2846

Figure 4-2 Front Cowl

## GRILLE REMOVAL

1. Park vehicle and chock the tires.
2. Disconnect the batteries. **See Disconnecting the Battery-Gasoline Vehicles on page 1-3.**
3. Remove HD bumper (if equipped). **See Brushguard Removal, Section 4, Page 4-2.**
4. Remove cowl. **See Cowl Removal on page 4-4.**
5. Loosen and remove the two M6 self-tapping fasteners (1) at the top of grille (7). **(Figure 4-3, Page 4-7).**
6. Loosen and remove the two lower left and right side bolts (1 and 7) that attach the grille and plastic bumper (6).
7. Remove charger receptacle (if equipped) by removing the three screws that attach the receptacle or disconnect connector (quick connect).

## GRILLE INSTALLATION

1. Connect the charger receptacle or connector (quick connect).
2. Install, but do not tighten upper M6 screws. (Do not tighten screws until plastic bumper is installed).
3. Lower grille holes are shared with the front bumper, ensure lower bumper screws are attached first then install grille.
4. Line up upper and lower bolt holes.
5. Install and tighten upper bolts, then lower right and left side bolts. Tighten to 44 in·lb (5 N·m).
6. Connect the batteries. **See Connecting the Battery-Gasoline Vehicles on page 1-3.**

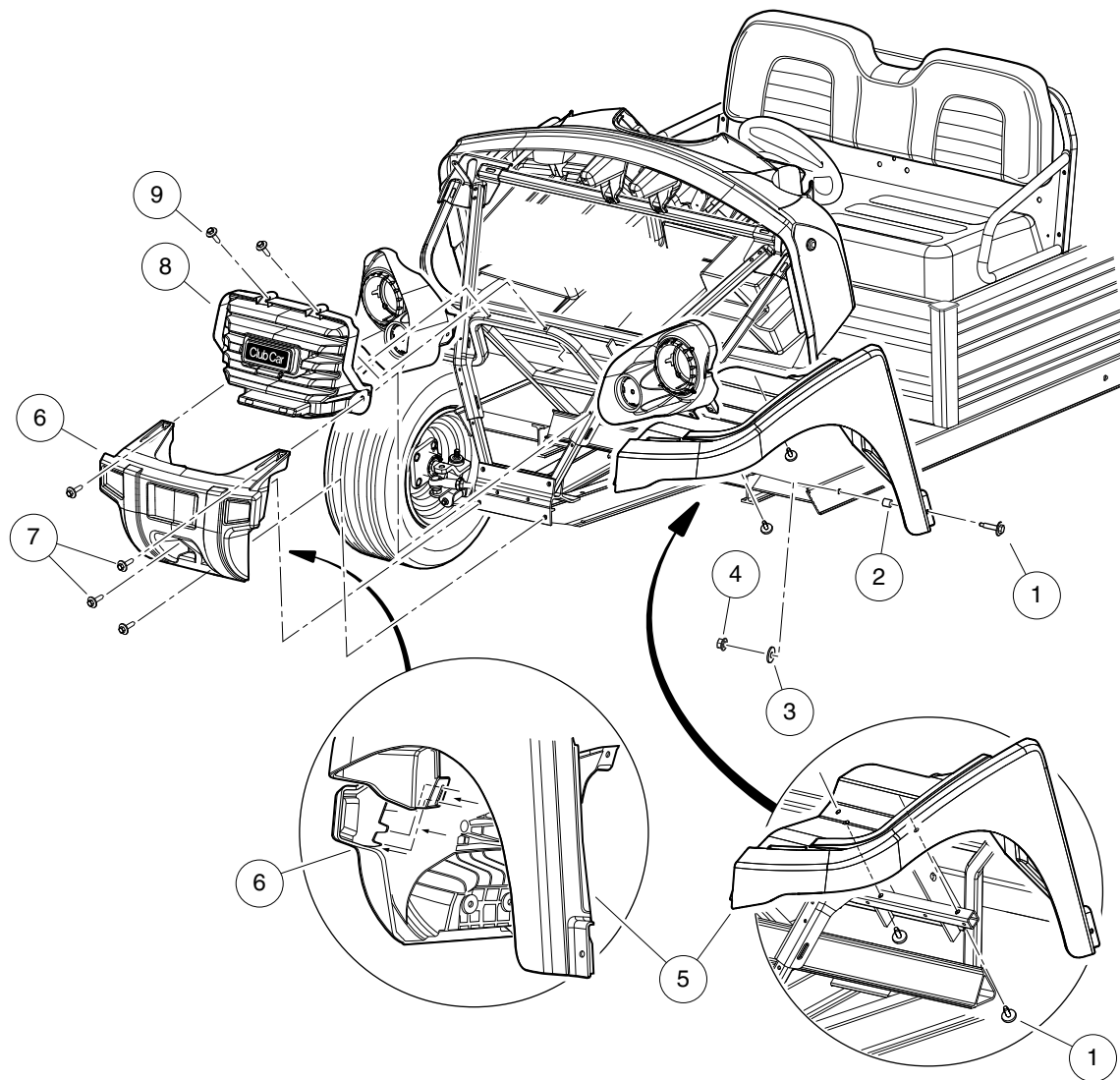

Figure 4-3 Front Grille, Bumper, and Side Fenders

## FRONT BUMPER AND SIDE FENDER REMOVAL

1. Park the vehicle, chock tires.
2. Disconnect the batteries. **See Disconnecting the Battery-Gasoline Vehicles on page 1-3.**
3. Remove HD bumper, (if equipped). **See Brushguard Removal on page 4-2.**
4. Remove cowl. **See Front Cowl on page 4-5.**
5. Remove the grille. **See Grille Removal on page 4-5.**
6. Loosen and remove the two upper and lower bolts (7) that attach the bumper to the vehicle frame. Push down and rearward on front fenders near the bumper (**Figure 4-3, Page 4-7**).
7. Remove front bumper (6).
8. Loosen and remove the inner screws, nuts, and spacers (1, 2, 3, and 4) that attach the side fender to the frame (repeat procedure on opposite side).
9. Unsnap body clips and remove side fenders (5).

## FRONT BUMPER AND SIDE FENDER INSTALLATION

1. Install side fenders (5) by snapping in body clips.
2. Install inner screws, nuts, and spacers (1, 2, 3, and 4) that attach the side fender to the frame.
3. Install front bumper (6).
4. Install the two upper and lower bolts (7) that attach the bumper to the vehicle frame. Push down and rearward on front fenders near the bumper to install.
5. Install the grille. **See Grille Installation, Section 4, Page 4-6.**
6. Install the front cowl. **See Cowl Installation, Section 4, Page 4-4.**
7. Install HD bumper (if equipped). **See Brushguard Installation, Section 4, Page 4-3.**
8. Connect the batteries. **See Connecting the Battery-Gasoline Vehicles on page 1-3.**
9. Remove tire chocks.



## INSTRUMENT PANEL REMOVAL

1. Disconnect the batteries. **See Disconnecting the Battery-Gasoline Vehicles on page 1-3.**
2. Remove front cowl. **See Cowl Removal, Section 4, Page 4-4.**
3. From the inside of the dash, press upper snap tabs (1) of the instrument panel inward to release from dash.
4. Then push the instrument panel near the bottom (2) to pop out the lower body clips (be careful not to pry the lower clips off).
5. Pull instrument panel out from the dash panel (2).

## INSTRUMENT PANEL INSTALLATION

1. Place upper tab of instrument panel into slot (1).
2. Snap panel into dash while pushing in on the driver and passenger side tabs and sliding the top portion of the panel into place.
3. Snap lower body clips in at each lower corner.
4. Connect the batteries. **See Connecting the Battery-Gasoline Vehicles on page 1-3.**

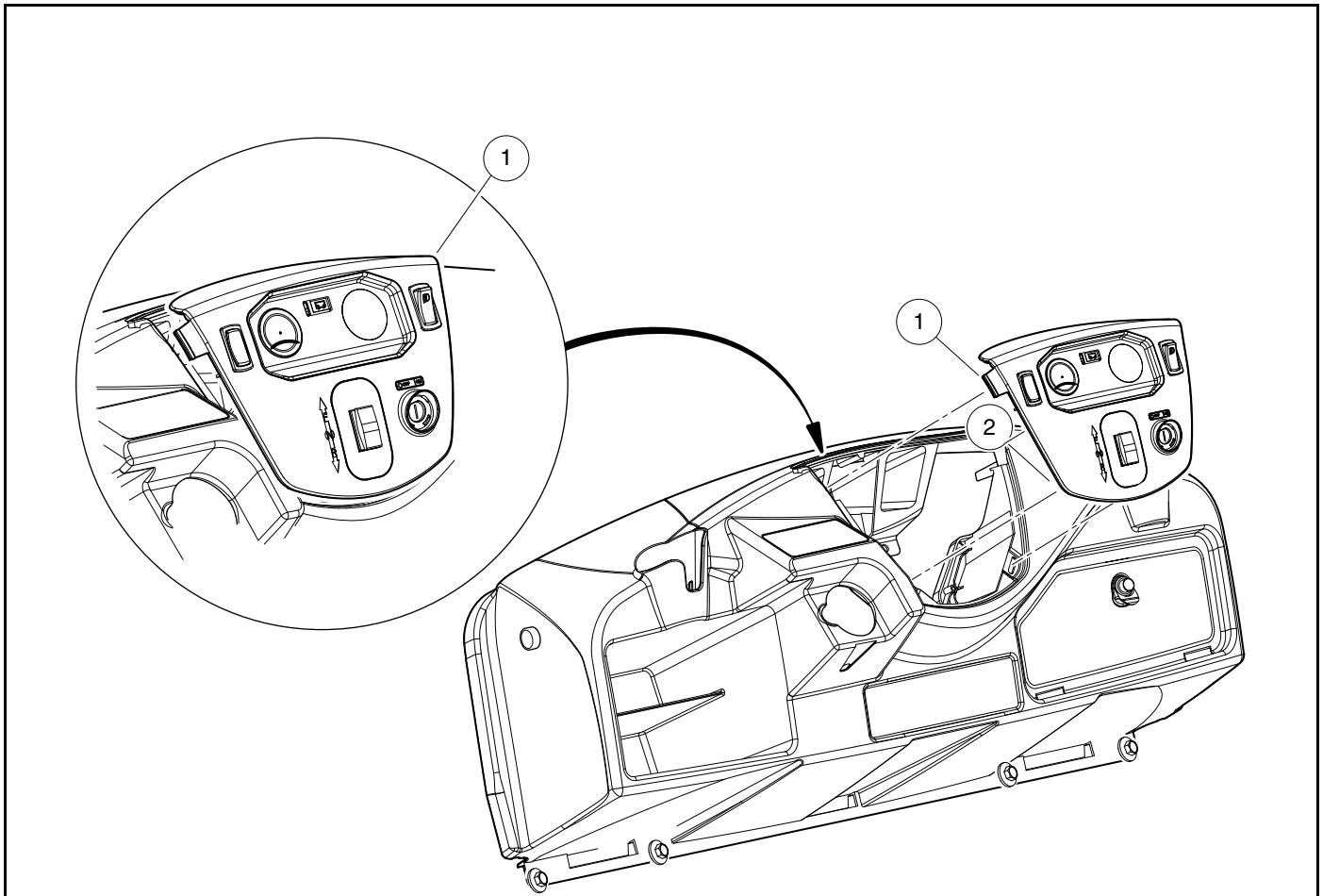

2946

**Figure 4-4 Instrument Panel**

## DASH REMOVAL

1. Disconnect the batteries. **See Disconnecting the Battery-Gasoline Vehicles on page 1-3.**
2. Remove cowl. **See Cowl Removal on page 4-4.**
3. Remove steering wheel. **See Steering Wheel Removal, Section 7, Page 7-1.**
4. Disconnect instrument panel wiring.
5. Remove the bolts, and washers (5, 6, 7, 8, and 9) from the top, sides and bottom of the dash (10). **(Figure 4-5, Page 4-11).**
6. Remove dash assembly.

## DASH INSTALLATION

1. Install dash assembly.
2. Install the bolts, and washers (5, 6, 7, 8, and 9) to the top, sides and bottom of dash (10). **(Figure 4-5, Page 4-11).**
3. Connect instrument panel wiring.
4. Install steering wheel. **See Steering Wheel Installation, Section 7, Page 7-2.**
5. Install cowl. **See Cowl Installation, Section 4, Page 4-4.**
6. Connect the batteries. **See Connecting the Battery-Gasoline Vehicles on page 1-3.**

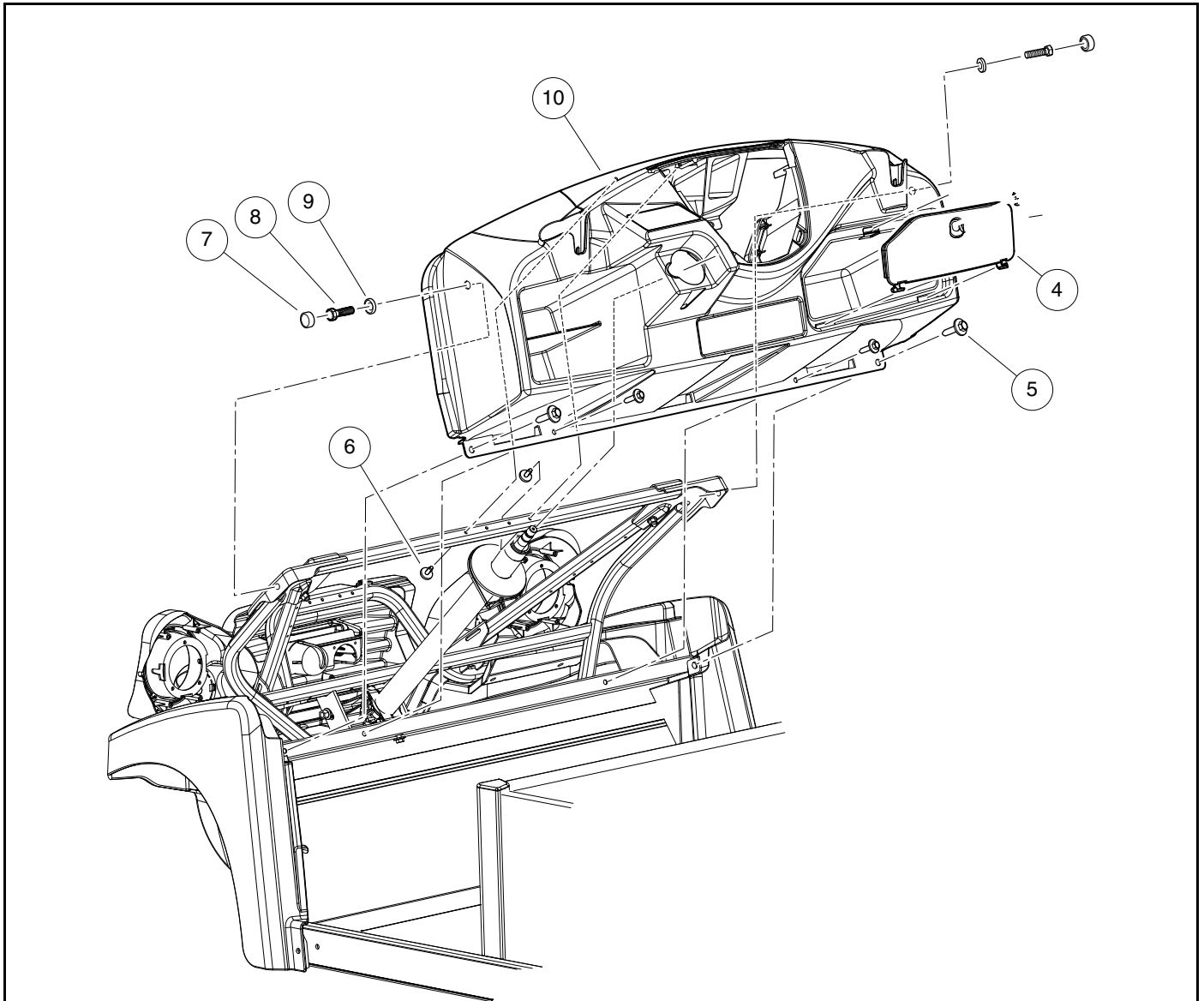

2863

Figure 4-5 Dash Assembly

---

## TILT BED

---

See General Warnings on page 1-1.

### TILT BED REMOVAL

**NOTE:** This procedure requires two people.

#### **⚠ WARNING**

- **Remove all cargo before raising the bed or servicing the vehicle. If the vehicle is equipped with a prop rod, ensure that it is securely engaged while bed is raised. Do not close bed until all persons are clear of cargo bed area. Keep hands clear of all crush areas. Do not drop cargo bed; lower gently and keep entire body clear. Failure to heed this warning could result in severe personal injury or death.**
1. Raise bed and secure prop rod (9) in prop rod track (2). Hold bed securely in an upright position. Remove cotter pin (11) and flat washer (17) from top end of prop rod where prop rod attaches to bed. Remove prop rod (9) from bed and place prop rod between prop rod track (2) and rear body panel. Lower bed onto vehicle frame (**Figure 4-6, Page 4-13**).
  2. Remove two lock nuts (8) from left and right hinge assemblies (C).
  3. Apply slight upward pressure (by hand) on the rear of the bed to relieve pressure on the hinges, and remove the hinge bolts (7) from the hinge assemblies.
  4. Raise rear edge of bed approximately 6 inches (15.2 cm) and pull bed assembly toward rear of vehicle approximately 3 inches (7.6 cm) to release bed latch assembly (A) from latch plate (B).
  5. Lift bed from vehicle.

### TILT BED INSTALLATION

**NOTE:** This procedure requires two people.

*Lubricate the hinge bolts (7) with light motor oil prior to assembly.*

1. Place bed on vehicle. Hold bed at a slight angle (front of bed lower than rear of bed) to vehicle and push front edge of bed onto vehicle frame engaging bed latch assembly (A) with latch plates (B).
2. Install bolt (7) into each hinge assembly.
3. Install a nylon lock nut (8) on each bolt (7) and tighten to 15 ft·lb (21 N·m).
4. Lift bed and insert the prop rod (9) in bed mounting hole. Install a 3/8-inch flat washer (17) and a new cotter pin (11) on prop rod.

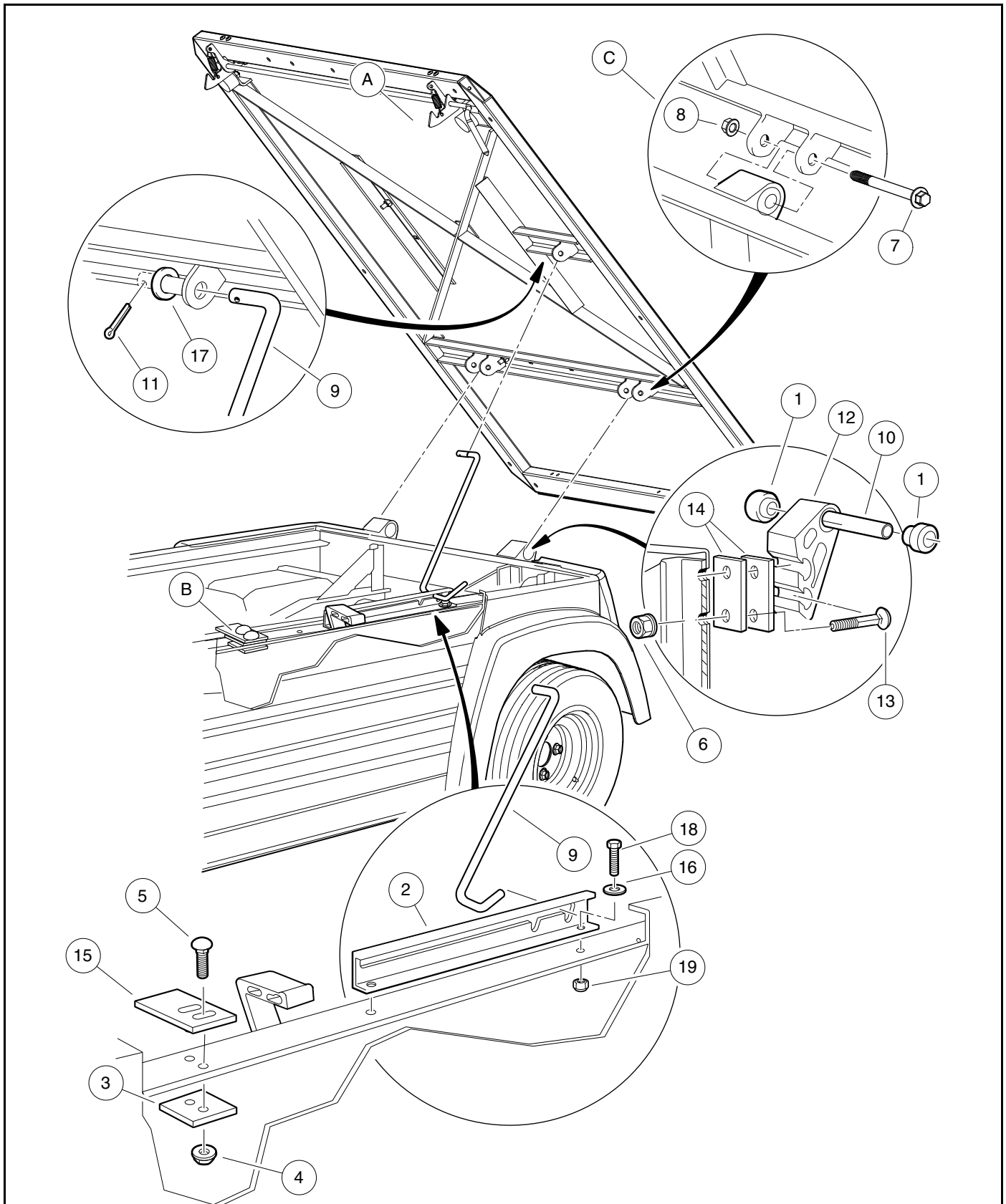

2980

Figure 4-6 Tilt Bed Mounting

## BED LATCH ASSEMBLY REMOVAL

**NOTE:** This procedure requires the aid of an assistant.

1. Park the vehicle and chock the tires.
2. Disconnect the batteries. **See Disconnecting the Battery-Gasoline Vehicles on page 1-3.**
3. Raise bed and secure prop rod (9) in prop rod track (2) (**Figure 4-6, Page 4-13**). **See following WARNING.**

### **⚠ WARNING**

- **Remove all cargo before raising the bed or servicing the vehicle. If the vehicle is equipped with a prop rod, ensure that it is securely engaged while bed is raised. Do not close bed until all persons are clear of cargo bed area. Keep hands clear of all crush areas. Do not drop cargo bed; lower gently and keep entire body clear. Failure to heed this warning could result in severe personal injury or death.**
4. Remove the four bolts (12) and lock nuts (7) that secure the bed latch (6) to the underside of the bed (**Figure 4-7, Page 4-15**).
  5. Remove the bed latch (6) and springs (5).

## BED LATCH ASSEMBLY INSTALLATION

1. Install bed latch (6) and springs (5).

**NOTE:** Latch assembly needs to sit open exactly as shown (**Figure 4-7, Page 4-15**).

2. Install the four bolts (12) and lock nuts (7) that secure the bed latch (6) to the underside of the bed. Tighten to 70 to 80 in·lb (8 to 9 N·m).
3. Connect the batteries. **See Connecting the Battery-Gasoline Vehicles on page 1-3.**
4. Remove tire chocks.

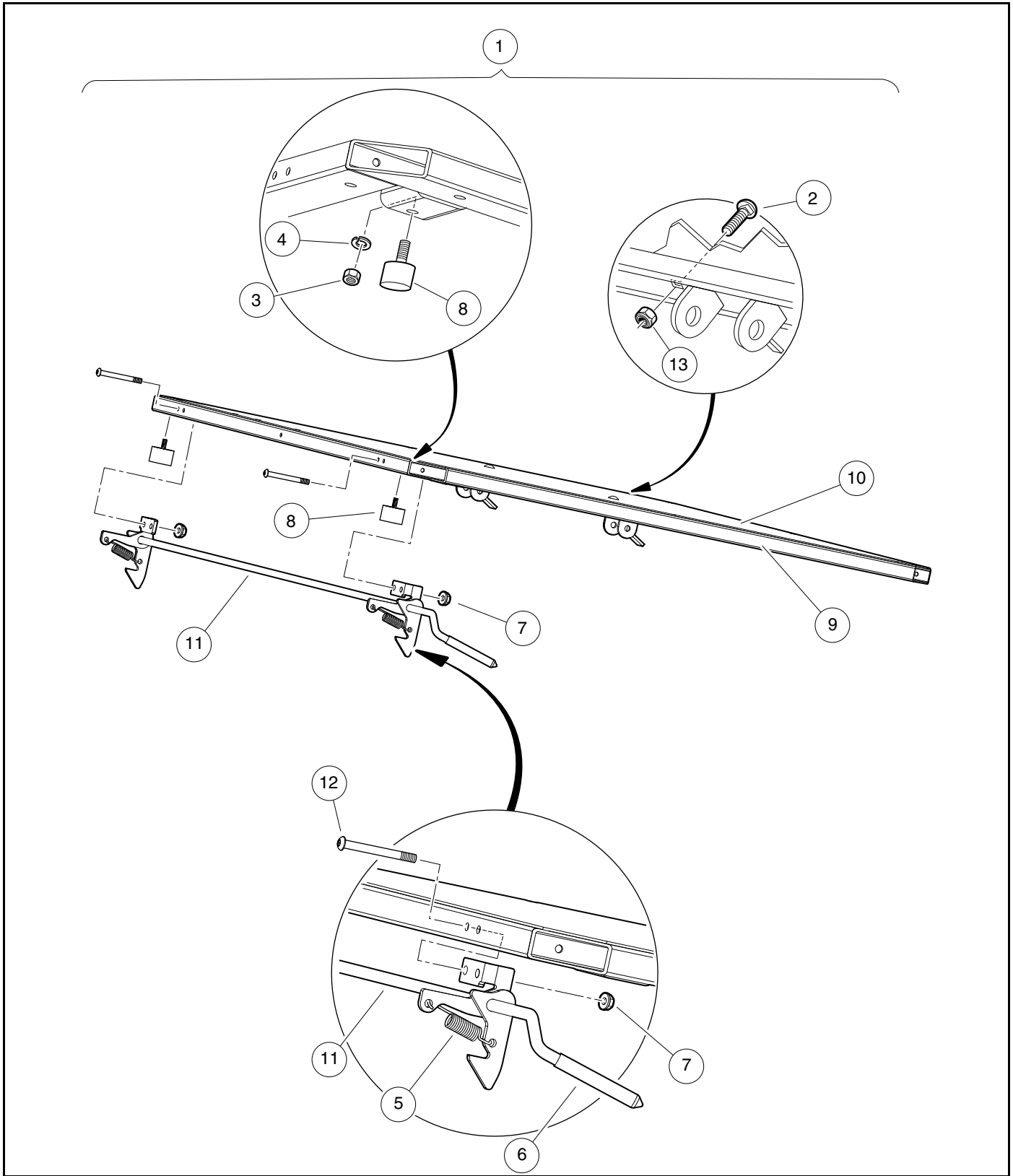

2982

Figure 4-7 Bed Latch Assembly

---

## REAR FENDERS AND TAILSKIRT

---

See General Warnings on page 1-1.

### REAR FENDER AND TAILSKIRT REMOVAL

1. Turn the key switch OFF and remove the key. Place the Forward/Reverse handle in NEUTRAL and set the park brake. Chock the wheels.
2. Disconnect the battery cables and either discharge the controller or disconnect the spark plug wire(s). See **Disconnecting the Battery-Gasoline Vehicles on page 1-3**.
3. Remove the tilt bed. See **Tilt Bed Removal on page 4-12**.
4. Disconnect the three taillight wires.
5. Using a 10 mm socket, remove the three fasteners (5) that attach the rear fender (4) to vehicle frame (**Figure 4-8, Page 4-17**).
6. Using a 10 mm socket, remove the two M6 screws (2) that attach the tailskirt (3) to the vehicle frame.
7. Remove fenders and tailskirt.

### REAR FENDER AND TAILSKIRT INSTALLATION

1. Using a 10 mm socket, install the two screws (2) that attach the tailskirt (3) to the vehicle frame (**Figure 4-8, Page 4-17**). Tighten to 44 in·lb (5 N·m).
2. Using a 10 mm socket, install the three fasteners (5) that attach the rear fender (4) to the vehicle frame. Tighten to 5 in·lb (0.56 N·m). Do not over torque.
3. Connect the taillight wires.
4. Install the two bolts and nuts that secure taillight to the rear fender.
5. Connect the three taillight wires.
6. Install the tilt bed. See **Tilt Bed Installation on page 4-12**.
7. Connect the batteries. See **Connecting the Battery-Gasoline Vehicles on page 1-3**.



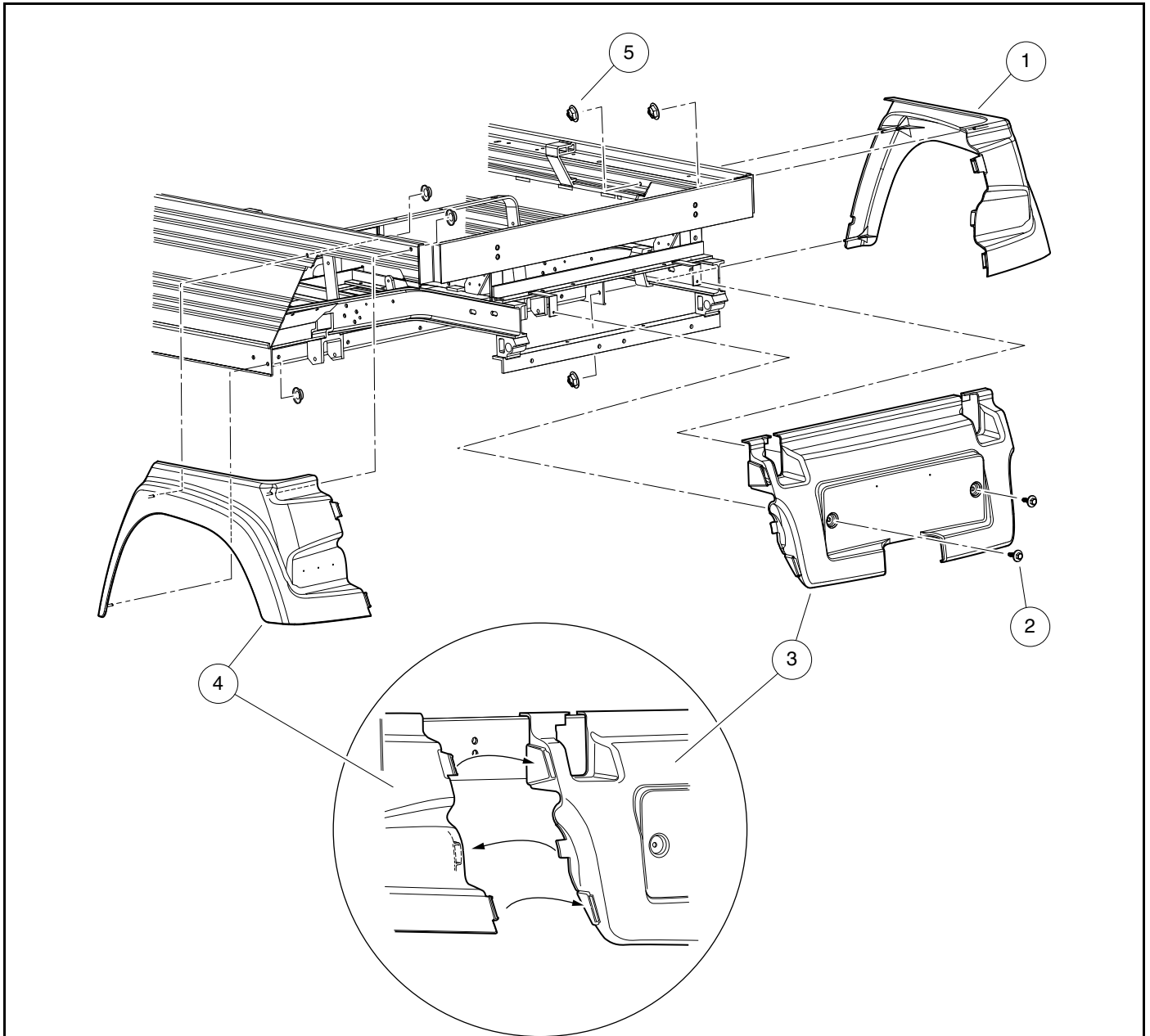

2984

Figure 4-8 Rear Fender and Tailskirt



## ELECTRIC BED LIFT REMOVAL

**NOTE:** For vehicles equipped with an electric bed lift.

*This procedure requires the aid of an assistant.*

1. Disconnect the batteries. **See Disconnecting the Battery-Gasoline Vehicles on page 1-3.**
2. Raise the bed.
3. Disconnect actuator wires.
4. Remove actuator hardware that secures lift (7) (**Figure 4-9, Page 4-18**).
5. Lower the bed.
6. Remove the hex-head bolts, lock nuts, spacers and bushings (1, 2, 5, 6, 7, and 8) (**Figure 4-10, Page 4-20**).

## ELECTRIC BED LIFT INSTALLATION

1. Install hex-head bolts, lock nuts, spacers and bushings (1, 2, 5, 6, 7, and 8) (**Figure 4-10, Page 4-20**).
2. Lift bed.
3. Install actuator hardware that secures lift (7) (**Figure 4-9, Page 4-18**).
4. Connect actuator wires.
5. Lower bed.
6. Connect the batteries. **See Connecting the Battery-Gasoline Vehicles on page 1-3.**

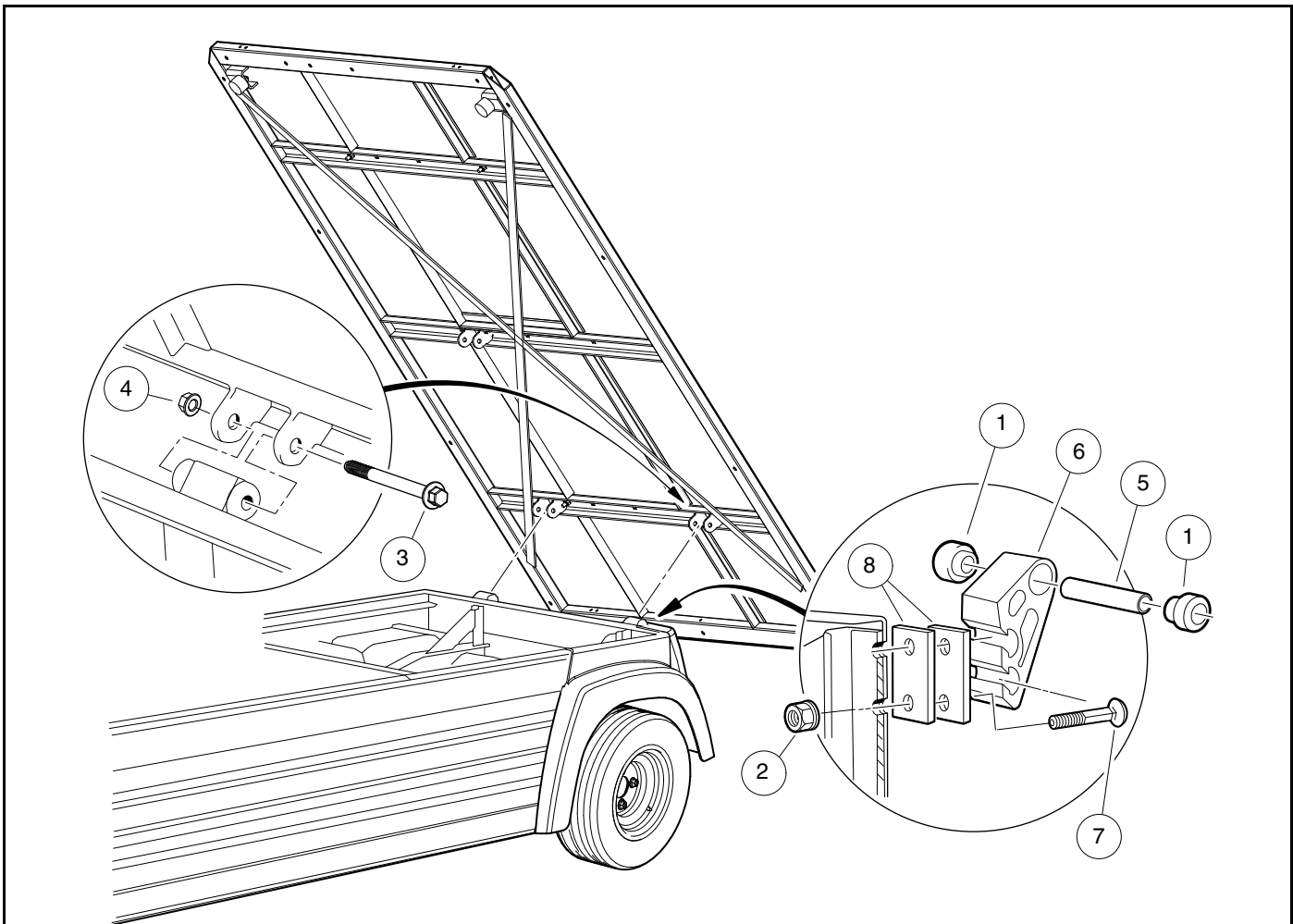

2985

Figure 4-10 Electric Bed Mounting

## FLOOR MAT

See General Warnings on page 1-1.

### FLOOR MAT REMOVAL

1. Remove the brake and accelerator pedals. **See Accelerator and Brake Pedal Group, Section 5, Page 5-1.**
2. Remove the top edge of the floor mat from the overlapping flange under the dash.
3. Lift the mat from the vehicle.

### FLOOR MAT INSTALLATION

1. Install mat into vehicle. Ensure mat is laying flat.
2. Install top edge of the floor mat into the overlapping flange under the dash.
3. Install the brake and accelerator pedals. **See Accelerator and Brake Pedal Group, Section 5, Page 5-1.**

### **⚠ DANGER**

- See General Warnings on page 1-1.

### **⚠ WARNING**

- See General Warnings on page 1-1.

## **BRAKE PEDAL AND PARK BRAKE**

### **BRAKE PEDAL REMOVAL (GAS AND ELECTRIC VEHICLES)**

1. Disconnect the battery cables and either discharge the controller or disconnect the spark plug wire(s). **See Disconnecting the Battery-Gasoline Vehicles on page 1-3.**
2. Place chocks under the rear wheels and lift the front end of the vehicle with a chain hoist or floor jack. Place jack stands under the front cross tube of the vehicle frame and lower the vehicle onto the jack stands. **See following WARNING.**

### **⚠ WARNING**

- **Lift only one end of the vehicle at a time. Use a suitable lifting device (chain hoist or hydraulic floor jack) with 1000 lb (454 kg) minimum lifting capacity. Do not use lifting device to hold vehicle in raised position. Use approved jack stands of proper weight capacity to support the vehicle and chock the wheels that remain on the floor. When not performing a test or service procedure that requires movement of the wheels, lock the brakes.**
3. Remove the brake pedal assembly.
    - 3.1. Disconnect the equalizer rod (5 and 6) from the pedal shaft by removing the clevis pin (7) and bow-tie pin (4) (**Figure 5-1, Page 5-2**).
    - 3.2. Remove the nuts (2), flat washers (10), bolts (11), and mounting blocks (3 and 8). If the mounting blocks (3 and 8) show signs of excessive wear or are damaged, they must be replaced with new ones before installing pedal assembly.
    - 3.3. Remove the nut (12) and brake stop bumper (13) and lift pedal assembly (1) through the floorboard (**Figure 5-2, Page 5-3**).

### **BRAKE PEDAL INSTALLATION (GAS AND ELECTRIC VEHICLES)**

1. From the top side of the floorboard, insert the brake pedal assembly (1) through the opening in the floor as shown (**Figure 5-2, Page 5-3**) and install the brake pedal stop bumper (13) (**Figure 5-1, Page 5-2**) on the brake pedal assembly, but do not tighten the jam nut (12) at this time.
2. Secure the equalizer rod (5 and 6) to the brake pedal assembly (1) with clevis pin (7) and bow-tie pin (4) as shown.

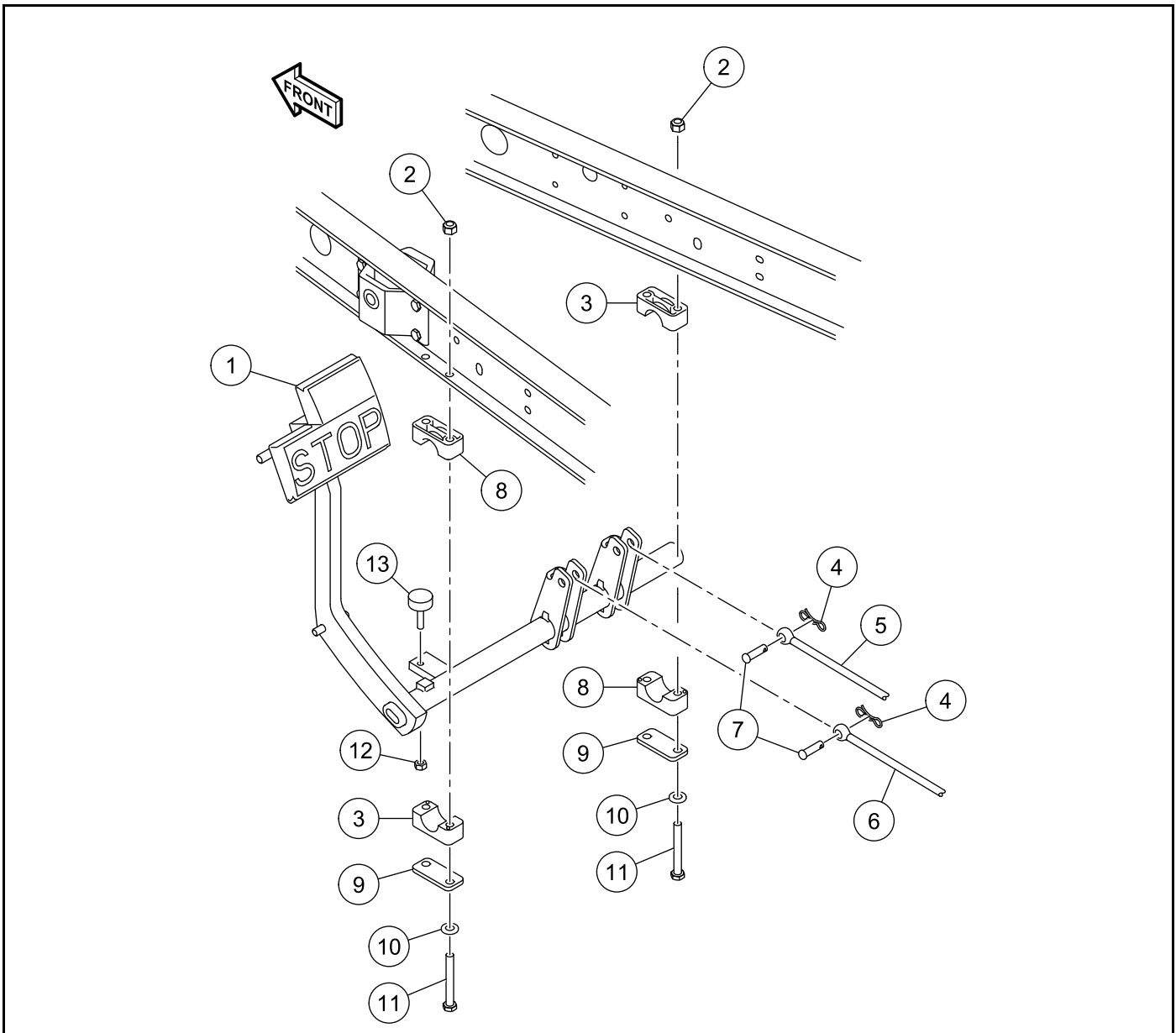

3207

Figure 5-1 Brake and Park Brake Pedal Assembly and Mounting

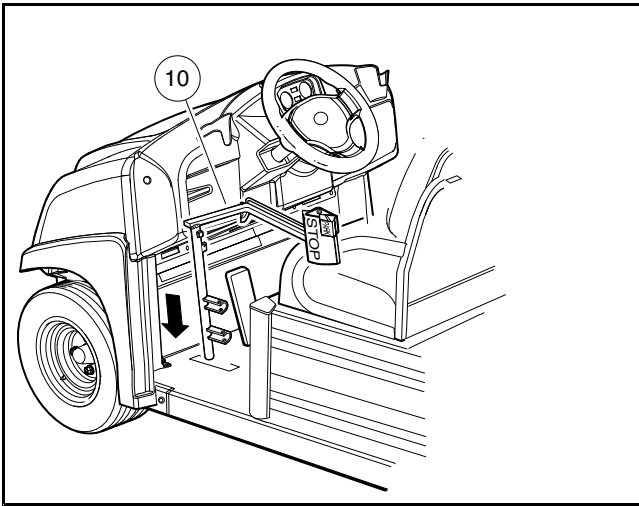

2999

Figure 5-2 Brake Pedal Weldment Through Floor

3. Position and attach brake pedal assembly, mounting blocks (3 and 8), and washers (10) to vehicle frame as shown. Tighten the bolts (11) and nuts to 95 in·lb (10.7 N·m). Figure 5-1, Page 5-2.
4. Tighten the nut (2) on the equalizer rod (1) so that brake pedal free-play is from 1/4 inch to 1/2 inch (6 mm to 13 mm) (Figure 5-3, Page 5-3). See following NOTE.

**NOTE:** Brake pedal free-play is the distance the brake pedal can be pressed before the brake actuator arm moves.

5. Tighten the jam nut (3) while holding the adjustment nut (2) in the correct position.
6. Adjust the pedal group. Refer to the appropriate adjustment procedure:
  - For gasoline vehicles, see Pedal Group Adjustment on page 5-7.

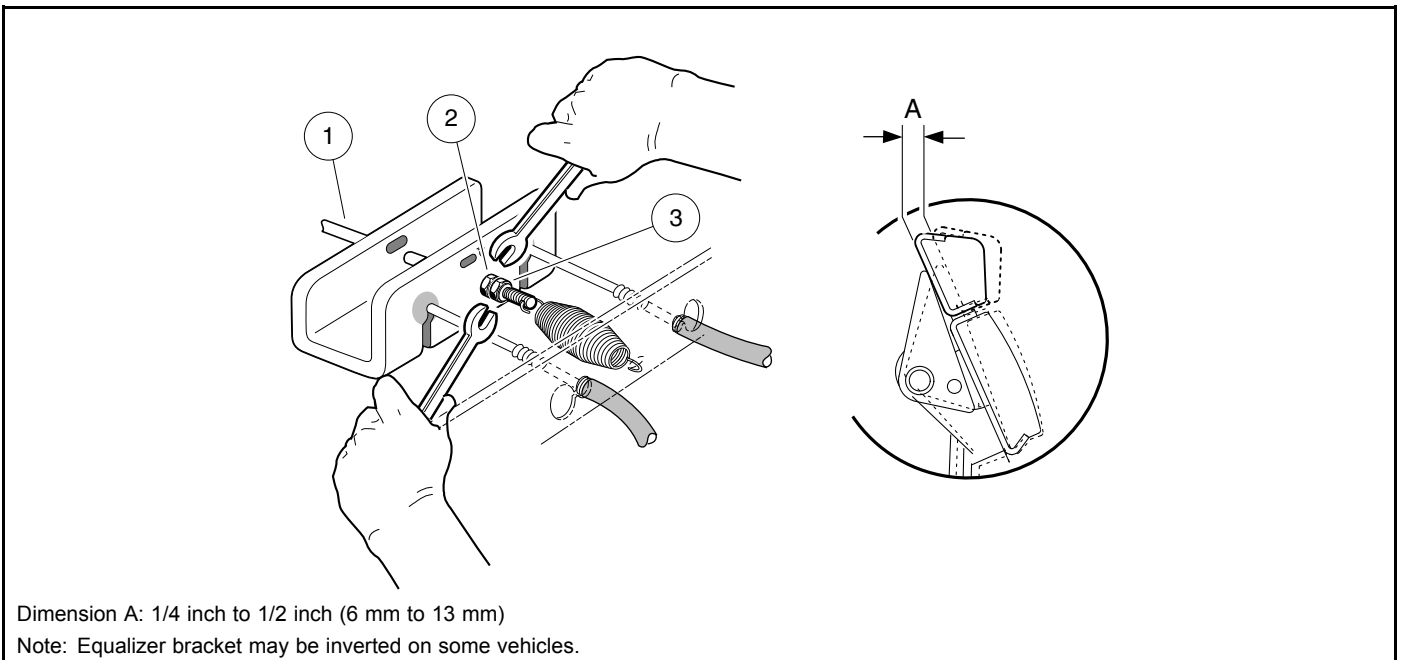

1369

Figure 5-3 Brake Pedal Free-Play Adjustment

## PARK BRAKE REMOVAL

1. Disconnect the battery cables and either discharge the controller or disconnect the spark plug wire(s). **See Disconnecting the Battery-Gasoline Vehicles on page 1-3.**
2. Place chocks under the rear wheels and lift the front end of the vehicle with a chain hoist or floor jack. Place jack stands under the front cross tube of the vehicle frame and lower the vehicle onto the jack stands. **See following WARNING.**

### **▲ WARNING**

- Lift only one end of the vehicle at a time. Use a suitable lifting device (chain hoist or hydraulic floor jack) with 1000 lb (454 kg) minimum lifting capacity. Do not use lifting device to hold vehicle in raised position. Use approved jack stands of proper weight capacity to support the vehicle and chock the wheels that remain on the floor. When not performing a test or service procedure that requires movement of the wheels, lock the brakes.

3. Remove the park brake assembly.
  - 3.1. To remove the park brake rod and pawl assembly (17 through 20), remove the push nut (19) and disconnect the ball joint sleeve (21) from the park brake pedal (1) (**Figure 5-4, Page 5-4**). **See following NOTE.**

**NOTE:** New push nuts (19) and (32) must be used when reassembling the park brake.

- 3.2. To remove the park brake pedal (1), remove the push retainer nut (32), disconnect the torsion spring (22) and slide the pedal off of the shaft. **See preceding NOTE.**
- 3.3. Inspect all parts for wear and damage and replace as necessary.

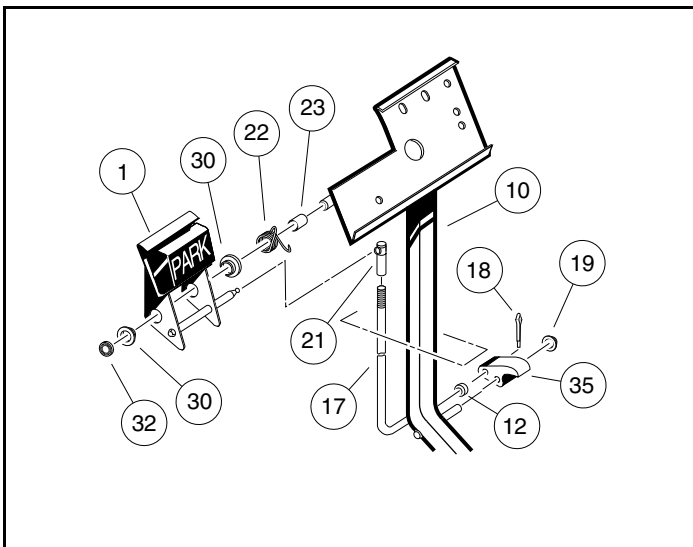

Figure 5-4 Park Brake Assembly

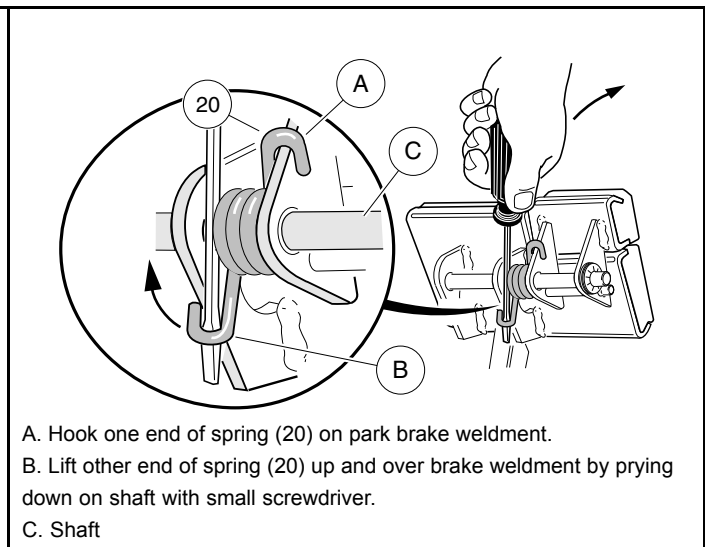

Figure 5-5 Torsion Spring Installation

## PARK BRAKE INSTALLATION

1. From the bottom side of the floorboard, insert the park brake rod (17) through the brake pedal assembly opening. Then install the park brake pawl (35) onto the shaft on the brake pedal assembly (10) and also insert the park brake rod (17) into the park brake pawl (**Figure 5-4, Page 5-4**).
2. Install the push nut (19) on to the park brake pawl shaft.
3. Install the spacer (23) and torsion spring (22) on the park brake pedal shaft on the brake pedal assembly.



4. Install the two bushings (30) in the park brake pedal and position the park brake pedal on the shaft on the brake pedal assembly weldment (10). Then attach the ends of the torsion spring to the park brake pedal and to the brake pedal weldment as shown (**Figure 5-5, Page 5-4**).
5. Install the push nut (32) on the park brake pedal shaft (**Figure 5-4, Page 5-4**).
6. Connect park brake rod (17) with ball joint (21) to the ball stud on the park brake pedal assembly.
7. Adjust park brake ratchet/pawl gap and pawl engagement. Refer to the appropriate adjustment procedure:
  - **For gasoline vehicles, see Pedal Group Adjustment on page 5-7.**

## ACCELERATOR PEDAL

See General Warnings on page 1-1.

### ACCELERATOR PEDAL REMOVAL – GASOLINE VEHICLES

1. Disconnect battery and spark plug wire(s). **See Disconnecting the Battery-Gasoline Vehicles on page 1-3.**
2. Place chocks under the rear wheels and lift the front end of the vehicle with a chain hoist or floor jack. Place jack stands under the front cross tube of the vehicle frame and lower the vehicle onto the jack stands. **See following WARNING.**

#### **▲ WARNING**

- **Lift only one end of the vehicle at a time. Use a suitable lifting device (chain hoist or hydraulic floor jack) with 1000 lb (454 kg) minimum lifting capacity. Do not use lifting device to hold vehicle in raised position. Use approved jack stands of proper weight capacity to support the vehicle and chock the wheels that remain on the floor. When not performing a test or service procedure that requires movement of the wheels, lock the brakes.**

3. Disconnect the accelerator rod assembly (17, 24, and 25) (**Figure 5-6, Page 5-6**) at the front and rear ball studs and remove it from the vehicle.
4. Use a 9/16-inch (14 mm) socket and 9/16-inch (14 mm) wrench to remove the nut (7), two washers (5), and bolt (4) securing the accelerator pedal (1) to the pivot rod (6).
5. Remove the nut (10) and ball stud (8) from the accelerator pivot rod assembly (6).
6. Slide the spring retainer (11) off of the accelerator pivot rod.
7. Inspect the pivot support bearing (9) for wear and replace if necessary.
8. Use a marker to mark the position of the park brake ratchet (23) on the accelerator pivot rod (6). **See following NOTE.**

**NOTE:** Failure to mark position of the ratchet could cause it to be reinstalled improperly, resulting in improper adjustment and possible failure of the park brake.

9. Remove the lock nut (26) from the accelerator pivot rod (**Figure 5-6, Page 5-6**).
10. Press the brake pedal slightly and slide the park brake ratchet (23) toward the end of the accelerator pivot rod. Rotate the ratchet and remove it from the pivot rod.
11. Remove the pivot rod (6) and spacer (20) from the accelerator pivot rod supports (21).
12. Inspect the accelerator pivot rod supports (21) for wear and damage and replace if necessary. If the pivot rod supports do not require replacement, loosen, but do not remove, the four bolts (22) and lock nuts (18) to make installation of the pivot rod easier.
13. Remove the accelerator pedal (1) from the vehicle.
14. Inspect all parts for wear and damage. Replace as necessary.

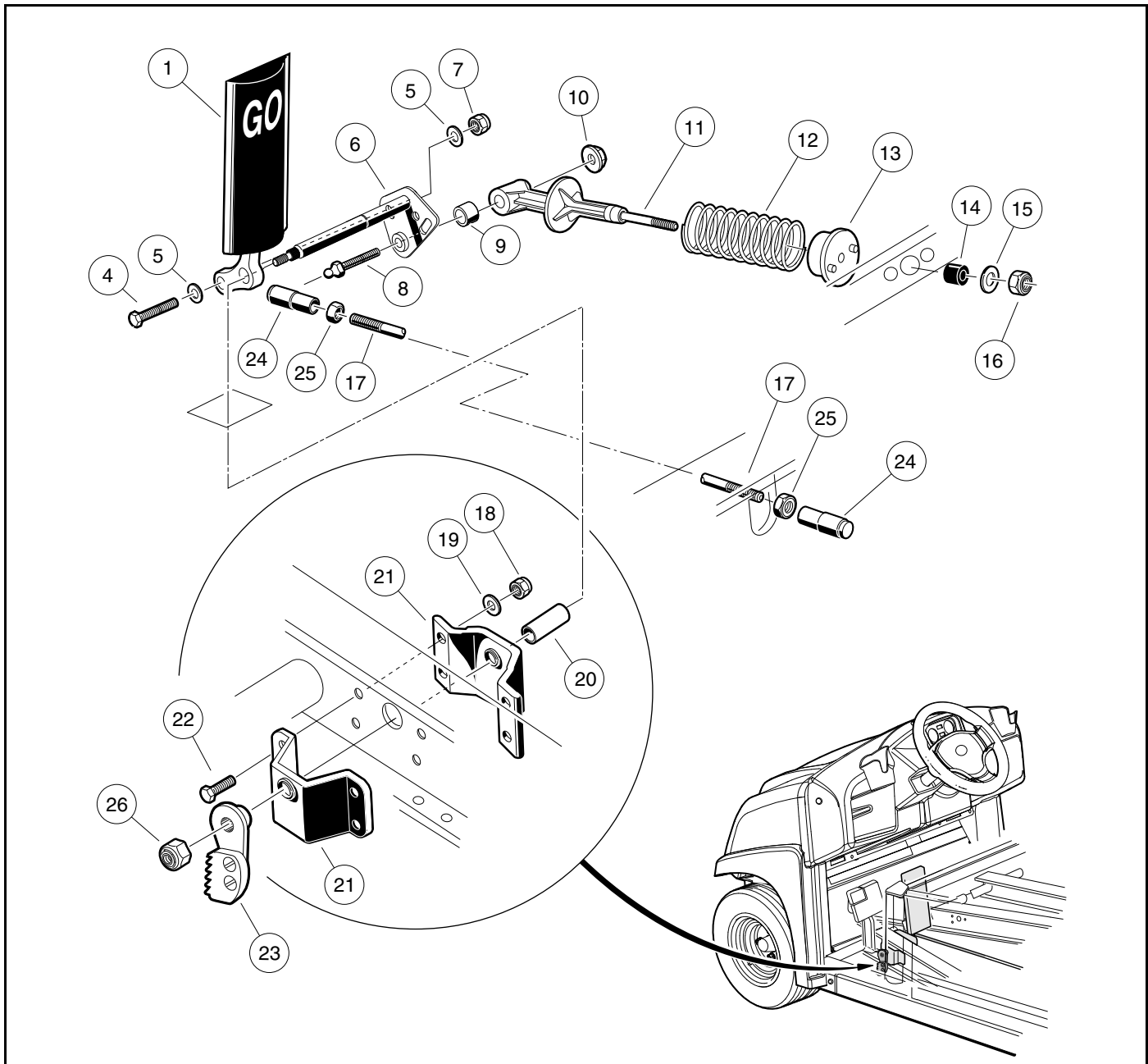

3000

Figure 5-6 Accelerator Pedal – Gasoline Vehicles

## ACCELERATOR PEDAL INSTALLATION – GASOLINE VEHICLES

1. If the accelerator pivot rod supports were replaced, position the supports (21) on the vehicle frame and install the four bolts (22), flat washers (19), and lock nuts (18). Finger-tighten nuts at this time (**Figure 5-6, Page 5-6**).
2. Insert the lower end of the accelerator pedal (1) through the floorboard and install the accelerator pivot rod (6) through the uppermost hole in the pedal.
3. Install the plastic spacer (20) on the pivot rod (6).
4. Insert the pivot rod through the pivot rod supports on the vehicle frame.
5. Tighten the four bolts (22) attaching the pivot rod supports to the frame to 75 in·lb (8.5 N·m).

6. Install the bolt (4), two washers (5), and a new lock nut (7) through the lower hole in the pedal and through the pivot rod. Finger-tighten nut at this time.
7. Install the ball stud (8) through the pivot rod. Install the bearing (9) and spring retainer (11) onto the ball stud. Secure these parts with the nut (10). Tighten the nut to 50 in·lb (5.7 N·m).
8. Press the brake pedal slightly, and with the park brake ratchet oriented so that the tip of the ratchet is pointed toward the rear of vehicle, slide the ratchet onto the pivot rod (do not slide the ratchet onto the pivot rod splines). Release the brake pedal and allow the ratchet to rotate until its tip is pointed downward (**Figure 5-7, Page 5-7**). The ratchet should now rotate freely on the rod.

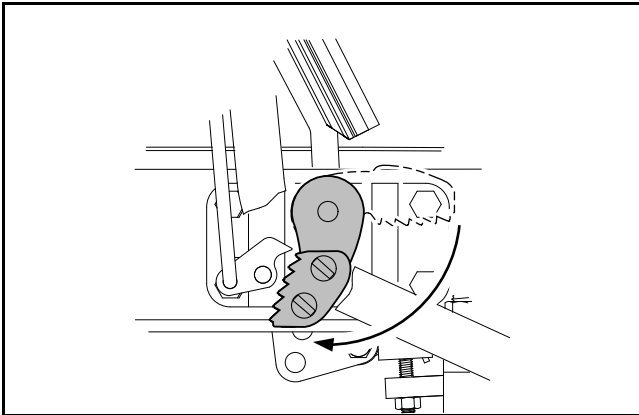

**Figure 5-7 Ratchet Installation**

9. Rotate the ratchet clockwise until it touches the park brake pawl, then slide the ratchet onto the splines of the pivot rod (it may be necessary to push the pivot rod toward the driver side of the vehicle to make the splines accessible). The ratchet may have to be rotated counterclockwise slightly to align the splines.
10. Install the nylon lock nut (26) on the pivot rod and tighten the nut to 18 ft·lb (24 N·m) (**Figure 5-6, Page 5-6**).
11. Install the accelerator rod assembly (17, 24, and 25).
12. Adjust the accelerator pedal height and accelerator rod. **See Pedal Group Adjustment on page 5-7.**

## PEDAL GROUP ADJUSTMENT

**See General Warnings on page 1-1.**

1. Disconnect battery and spark plug wire(s). **See Disconnecting the Battery-Gasoline Vehicles on page 1-3.**
2. Adjust brake pedal height.
  - 2.1. Chock wheels and release park brake. Lift rear of vehicle and place jack stands under the axle tubes to support the vehicle.
  - 2.2. To provide slack in the brake cables, loosen the equalizer retaining nuts (1) on the equalizer rod (2) (**Figure 5-8, Page 5-8**).

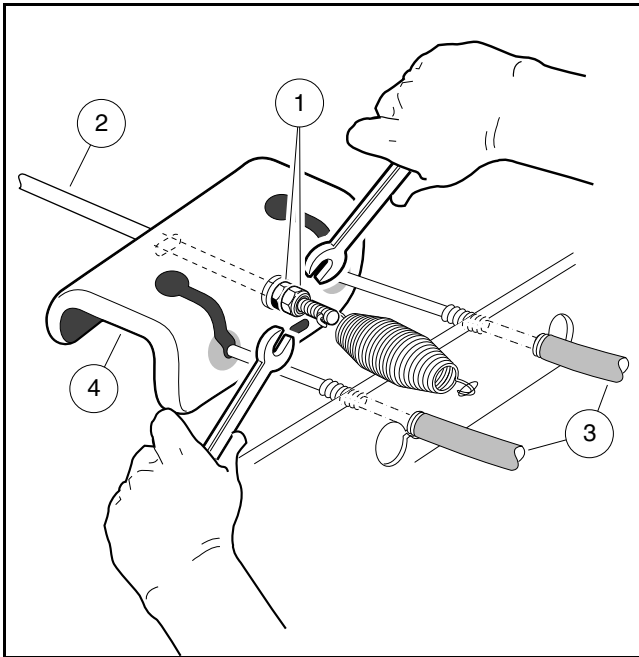

Figure 5-8 Loosen Rear Brake Equalizer Rod Nuts

- 2.3. Loosen the brake stop jam nut (31), then relieve pedal pressure on the stop by pushing down slightly on the pedal. Next, adjust the brake stop bumper (22) up or down (**Figure 5-9, Page 5-8**). Adjusting the bumper upward decreases distance between pedal and floorboard. Adjusting the bumper downward increases distance between pedal and floorboard. Proper brake pedal height is 6 inches (15.2 cm) (**Figure 5-10, Page 5-8**).
- 2.4. Tighten the jam nut (31) to 8 ft·lb (9.5 N·m) (**Figure 5-9, Page 5-8**).

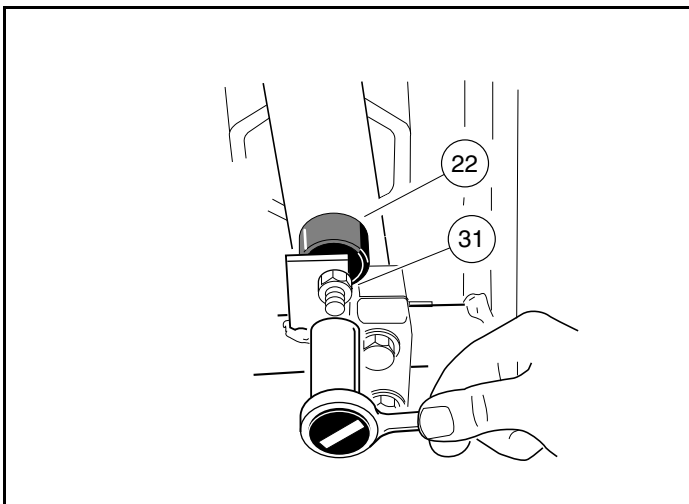

Figure 5-9 Brake Pedal Height Adjustment

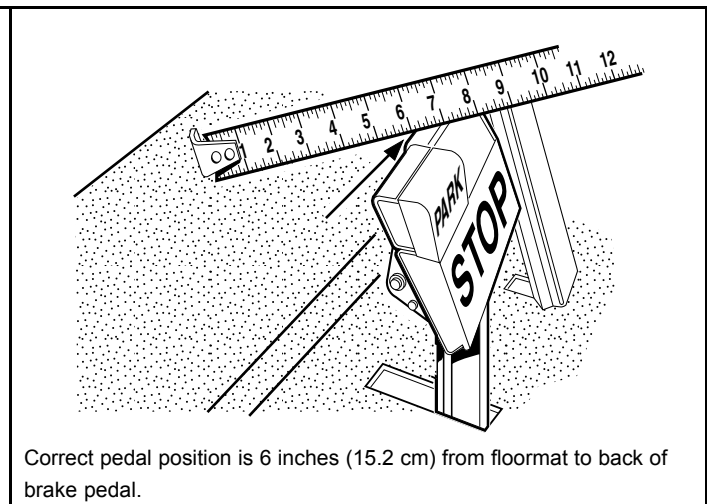

Figure 5-10 Brake Pedal Height Measurement

3. Adjust brake pedal free play. **See following NOTE.**

**NOTE:** Brake pedal free play is the distance the brake pedal can be pressed before the brake actuator arm (at the brake cluster) moves.

- 3.1. Measure perpendicularly from the floorboard to the back of the brake pedal, then press the brake pedal and measure the distance that the pedal moves before all of the slack is taken out of the brake cables (**Figure 5-10, Page 5-8**).

- 3.2. Tighten the nut (2) on the equalizer rod (1) so that the brake pedal free play is 1/4 to 1/2 inch (6 mm to 13 mm) (**Figure 5-3, Page 5-3**).
- 3.3. Tighten the jam nut (3) while holding the adjustment nut (2) in the correct position.
4. Adjust park brake ratchet/pawl gap and pawl engagement.
  - 4.1. Inspect the park brake pawl and ratchet for excessive wear, grooves, cracks, or chips. If either the pawl or ratchet is damaged, both must be replaced.
  - 4.2. Adjust retaining nut (7) on spring support rod until there is a 0.060 inch (1.5 mm) gap between the pawl and the tips of the ratchet teeth. Use a feeler gauge to verify the gap (**Figure 5-11, Page 5-9**). The gap should be consistent through range of pawl movement. If the gap is not consistent, loosen the four bolts (6) securing the accelerator pivot rod supports and adjust the supports. If the gap becomes smaller as the park brake pedal is pressed, move the pivot rod supports slightly rearward until the gap is consistent. If the gap becomes larger as the park brake pedal is pressed, move the pivot rod supports slightly forward until gap is consistent. **See following NOTE.**

**NOTE:** The accelerator rod must also be checked if the ratchet/pawl gap is adjusted. **See step 6.**

The accelerator rod must be disconnected before proceeding to the next step.

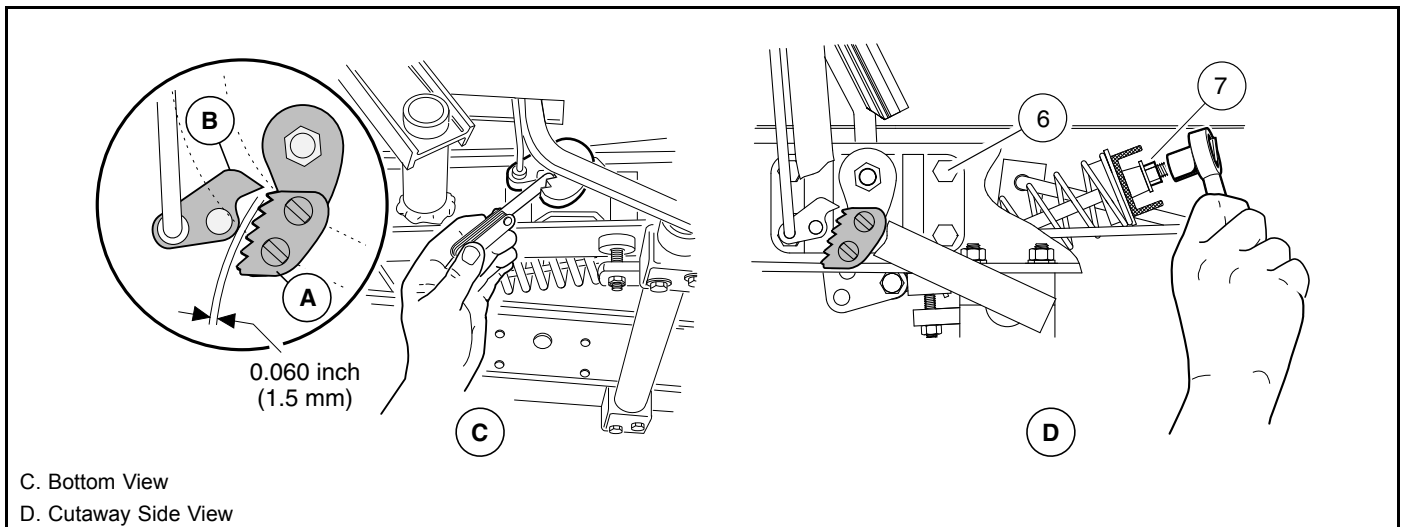

**Figure 5-11 Park Brake Ratchet/Pawl Gap Adjustment**

- 4.3. With the park brake unlocked, measure and note the distance from the top of the accelerator pedal to the floorboard, then lock the park brake (**Figure 5-12, Page 5-10**).
- 4.4. With the park brake locked, make sure at least 75% of ratchet tooth length engages the pawl (**Figure 5-13, Page 5-10**). Tooth engagement should be between the two lines marked on the pawl.

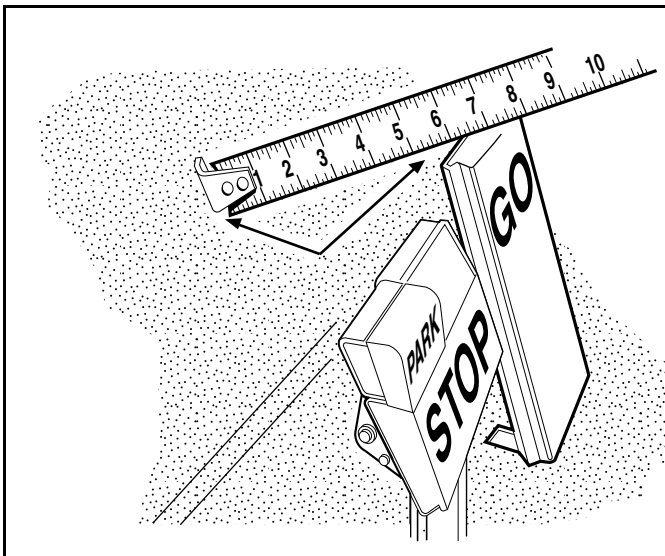

Figure 5-12 Accelerator Pedal Height Measurement

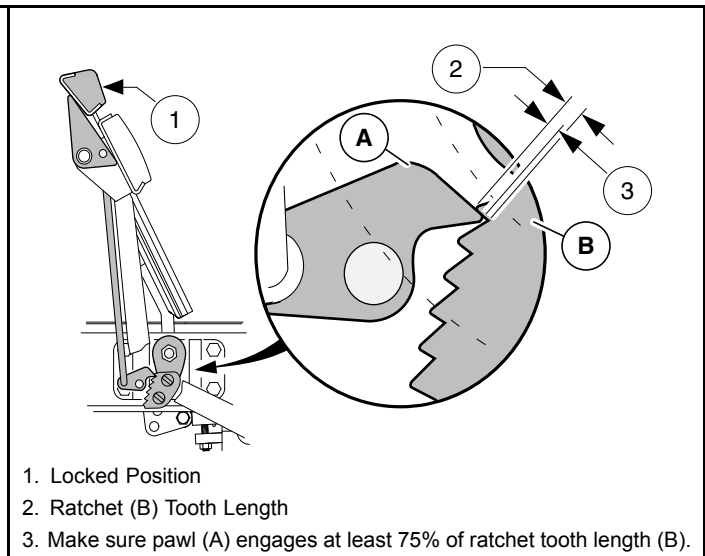

Figure 5-13 Ratchet/Pawl Tooth Engagement

- 4.5. With park brake still locked, measure the distance from the top of accelerator pedal to floorboard. If the measurement has changed, ratchet tooth engagement is too deep and must be adjusted.
- 4.6. If ratchet/pawl engagement must be adjusted, disconnect the ball joint at the top of the brake rod and rotate the ball joint sleeve clockwise to increase engagement or counterclockwise to decrease engagement. Reconnect ball joint (**Figure 5-14, Page 5-10**).
- 4.7. If the accelerator push rod was disconnected from the accelerator pedal, reconnect it.
- 4.8. Check for proper brake operation prior to driving the vehicle.

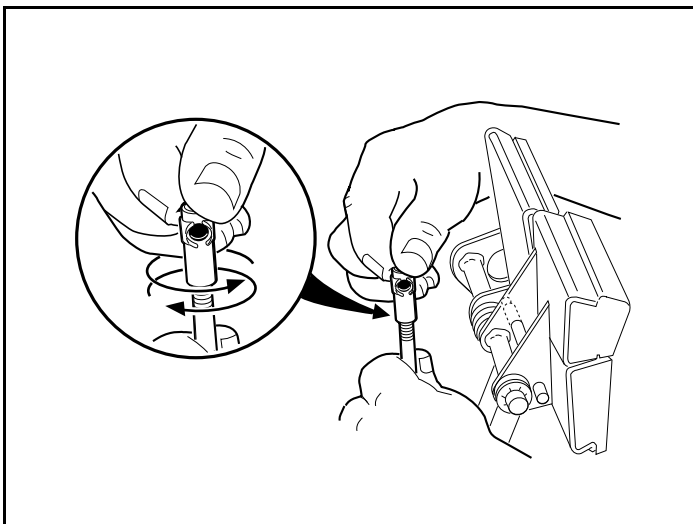

Figure 5-14 Brake Rod Adjustment

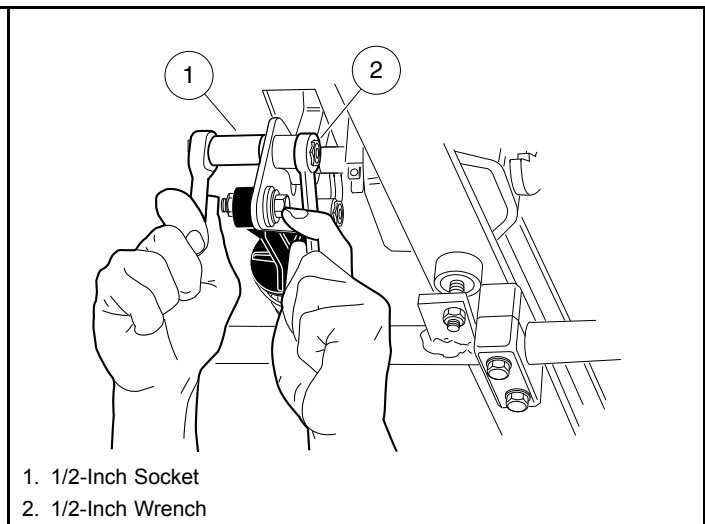

Figure 5-15 Accelerator Pedal Height Adjustment

5. Adjust accelerator pedal height.
  - 5.1. Loosen the nut and bolt (**Figure 5-15, Page 5-10**) securing the accelerator pedal to the pivot plate. Clamp the accelerator pedal adjustment tool to the accelerator pedal, with the end marked *accelerator pedal height* closest to the floorboard. Press the accelerator pedal until the end of the tool rests against the floorboard; pedal height should be 5-5/8 inches (14.3 cm). Use a rubber strap to hold pedal in position against the floorboard and then tighten nut to 26 ft·lb (35.3 N·m) (**Figure 5-16, Page 5-11**).

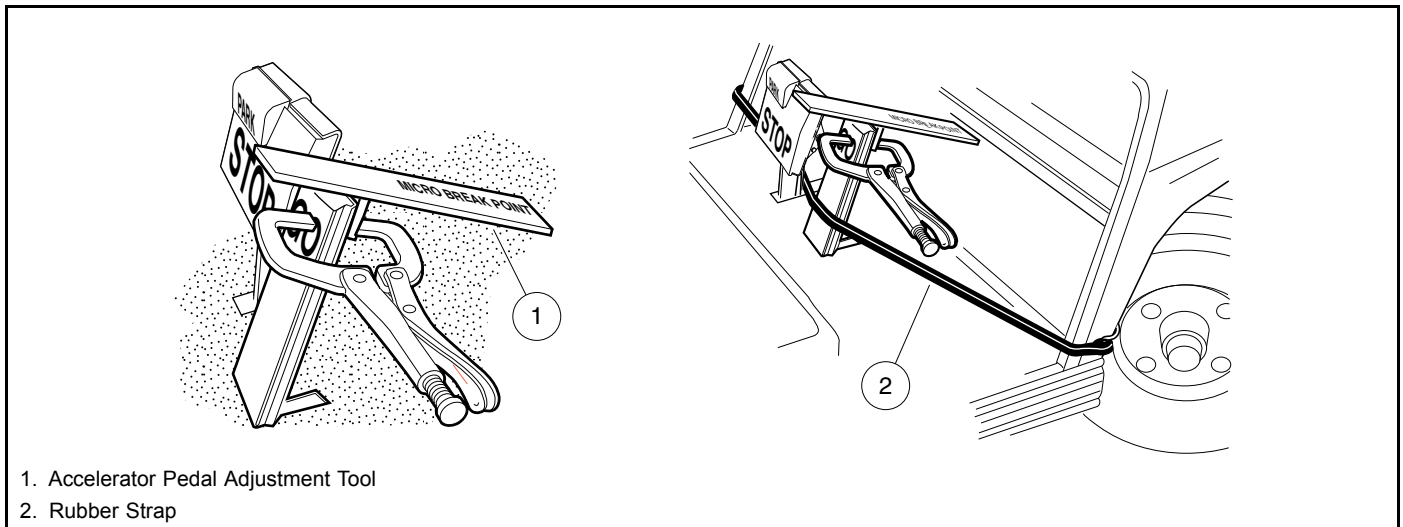

Figure 5-16 Accelerator Pedal Height Adjustment

6. Adjust the accelerator rod. **See following DANGER.**

### **⚠ DANGER**

- Before servicing, turn the key switch to the OFF position and place the Forward/Reverse handle in the NEUTRAL position.
- To prevent accidentally starting the vehicle, disconnect the battery cables as instructed. See **Disconnecting the Battery-Gasoline Vehicles** on page 1-3. This will prevent the possibility of the vehicle running over you when you are adjusting the accelerator rod.

- 6.1. Remove the electrical box screw and cover. **See preceding DANGER.**
- 6.2. Loosen the jam nuts (25) and disconnect the accelerator rod (17) at the accelerator pedal (**Figure 5-6, Page 5-6**). Adjust the length of the rod to obtain an accelerator cable cam position of 14° as shown (**Figure 5-17, Page 5-12**). **See following CAUTION.**

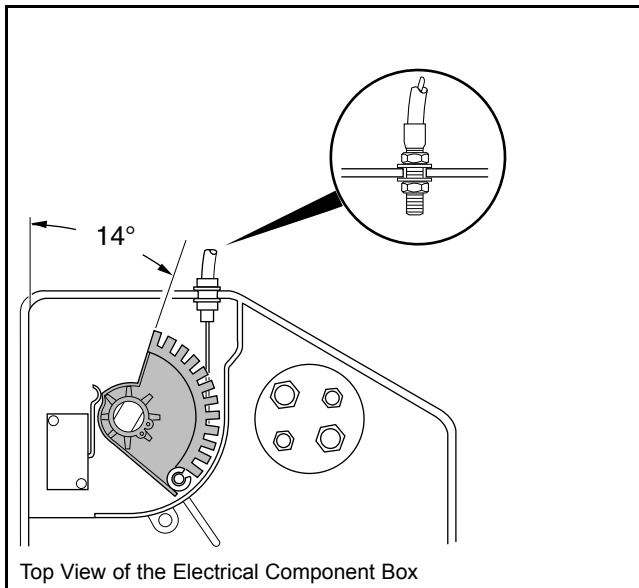

1344

Figure 5-17 Accelerator Cable

### **⚠ CAUTION**

- After accelerator rod adjustment, make sure that approximately the same number of threads are exposed at each end of the accelerator rod.
- If the lever on the limit switch in the electrical box is bent, replace the limit switch.
- When loosening jam nuts on the accelerator rod with one end disconnected, hold the disconnected accelerator rod with locking pliers.
- When tightening jam nuts on the accelerator rod, hold the disconnected ball joint with locking pliers.

6.3. Reconnect the accelerator rod at the accelerator pedal.

6.4. Before tightening jam nuts on accelerator rod, set park brake to first ratchet and pawl position. Press accelerator pedal and make sure the following events occur in the exact order shown:

EVENT	APPROXIMATE PEDAL TRAVEL
Park brake release	2° to 4°
Solenoid activation	4° to 8°
Carburetor throttle actuation	8° to 12°

6.5. If the events above occur as they should, hold the ball joint at each end of the accelerator rod with pliers and tighten the accelerator rod jam nut against it.

6.6. Ensure that the events occur as described in the table above. **See following NOTE.**

**NOTE:** After the pedal group and accelerator rod are adjusted, the final governed engine RPM should be set. **See Engine RPM Adjustment, Section 14, Page 14-10.**

6.7. Install the electrical box cover and screw.

6.8. Adjust the brakes. **See Brake Adjustment, Section 6, Page 6-7.**

6.9. Connect the battery cables. **See Connecting the Battery-Gasoline Vehicles on page 1-3.**



### **⚠ DANGER**

- See General Warnings on page 1-1.

### **⚠ WARNING**

- See General Warnings on page 1-1.

#### Asbestos Dust Warning

- Some aftermarket brake shoes contain asbestos fiber, and asbestos dust is created when these brake mechanisms are handled. Wear approved eye and respiratory protection when disassembling and cleaning brake mechanisms. Inhalation of asbestos could result in severe personal injury or death. Do not use compressed air or aerosol sprays to clean the brake mechanism. Clean brake mechanism using the negative pressure enclosure/hepa vacuum system or low pressure/wet cleaning method per OSHA/29 CFR - 1910.1001.

## GENERAL INFORMATION

The vehicles covered in this manual are equipped with a mechanical brake cable system to manually-adjusted drum brakes on all four wheels. **See Section 2 – Vehicle Specifications.**

## BRAKE SHOE REMOVAL

See General Warnings on page 1-1. See also Asbestos Dust Warning on page 6-1.

1. To remove rear brake shoes, place chocks at the front wheels, loosen the rear wheel lug nuts, and lift the rear of the vehicle with a chain hoist or floor jack. Place jack stands under the axle tubes to support the vehicle.
2. Release park brake if latched and loosen equalizer retaining nuts (1) on equalizer rod (2) to slightly loosen brake cable (**Figure 6-1, Page 6-2**).
3. Remove the rear wheels and brake drums. If the brake drums were easily removed, proceed to remove axle (for electric vehicles only) or remove wheel hub (for gasoline vehicles only). **See following CAUTION and NOTE.**

### **⚠ CAUTION**

- Worn or damaged brake drums cannot be machined to refinish them. Replace as necessary.
4. Removing brake drums with badly worn brake shoes.
    - 4.1. On the back of each brake cluster assembly, locate the heads of two brake shoe retainer pins. It may be necessary to remove sealant material around the head of each pin.

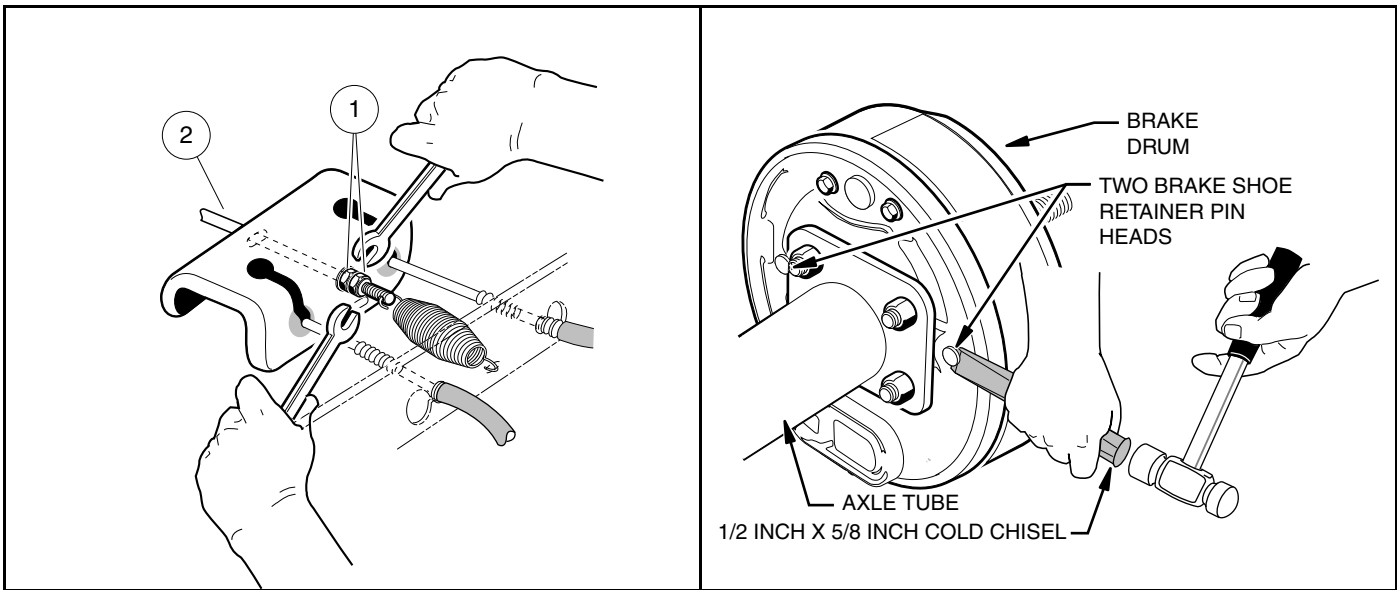

2814

Figure 6-1 Loosen Equalizer Nut

2834a

Figure 6-2 Shoe Retainer Pins

- 4.2. Insert a 1/2 inch x 5/8 inch cold chisel (1) under the head (2) of each pin and shear them off as illustrated (**Figure 6-2, Page 6-2**). This will release the shoes from the backing plate, allowing them to pivot away from the inside of the brake drum (3), which should then allow the brake drum to be pulled free. After completing step 6, skip step 7. **See following NOTE.**

**NOTE:** Although step 6 allows easier access to the brake shoes, it is not imperative to do so in order to remove the brake shoes.

5. **For gasoline vehicles:** Remove the wheel hub assembly. **See Rear Hub Removal, Section 17, Page 17-4.**
6. Using needle nose pliers, turn the clip retainer pin (1) 90° to remove the shoe retainer clip (2). (**Figure 6-3**) **See following CAUTION.**

### **⚠ CAUTION**

- The brake shoes are under spring pressure and can release suddenly when brake shoe retainers are removed.
7. Grasp both brake shoes and pull them, together with the springs, out of the brake assembly as shown. (**Figure 6-4**)

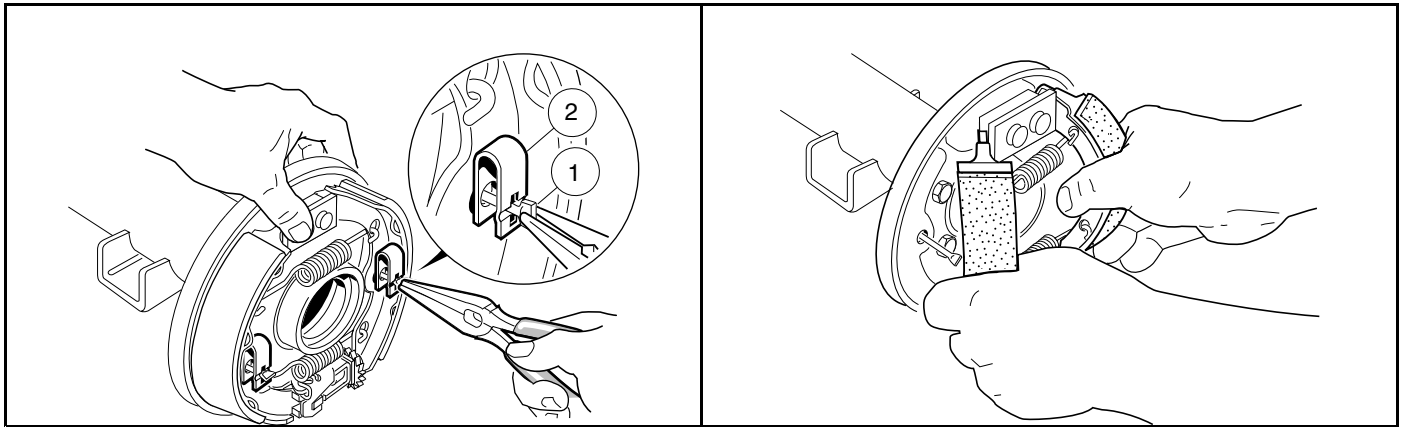

2824

Figure 6-3 Rotate Clip Retainer

2825

Figure 6-4 Remove Shoes

## BRAKE ASSEMBLY CLEANING

See General Warnings on page 1-1. See also Asbestos Dust Warning on page 6-1.

1. Carefully clean the brake backing plate and all mechanical components.
2. Remove the rubber boot from backing plate and wipe with a clean damp cloth.
3. Lubricate the slide (1) and slide plate (2) with dry moly lubricant on both sides of the backing plate (Figure 6-5, Page 6-3). After lubricating, work slide back and forth against backing plate to ensure that it slides smoothly and easily. Install rubber boot onto backing plate. Reinstall rubber boot onto backing plate. See following **WARNING**

### **⚠ WARNING**

- Apply grease carefully when performing the following steps. Do not allow any grease to get onto the friction surfaces of the brake shoe pads or the brake drum. Failure to heed this warning could cause diminished brake performance, possibly resulting in property damage or severe personal injury.

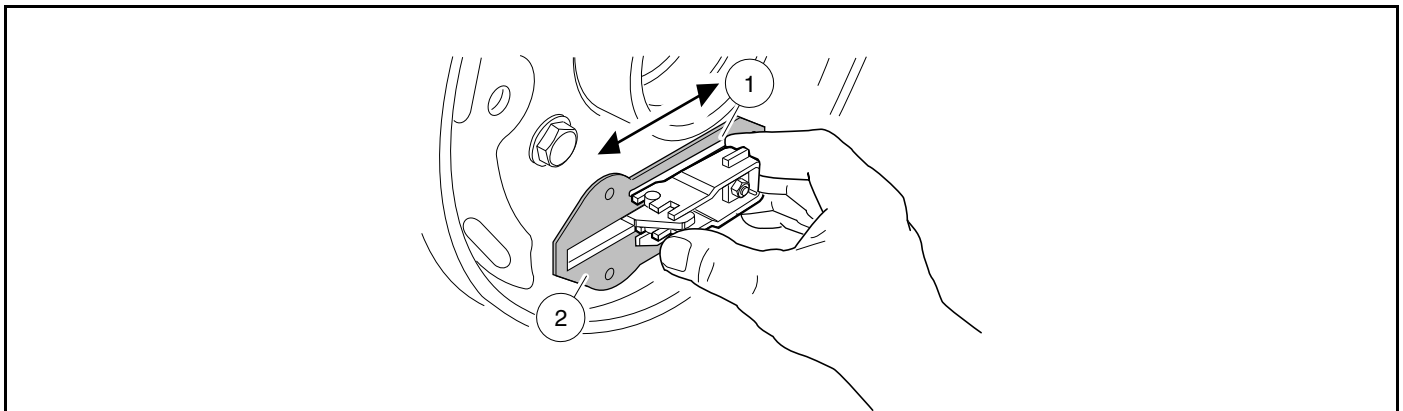

2816

Figure 6-5 Lubricate Slide

4. Use a small brush to carefully apply a light coat of white lithium NLGI #2 grease (Dow Corning® BR2-Plus or equivalent) on each of the six raised bosses on brake backing plate (**Figure 6-6**). **See preceding WARNING.**

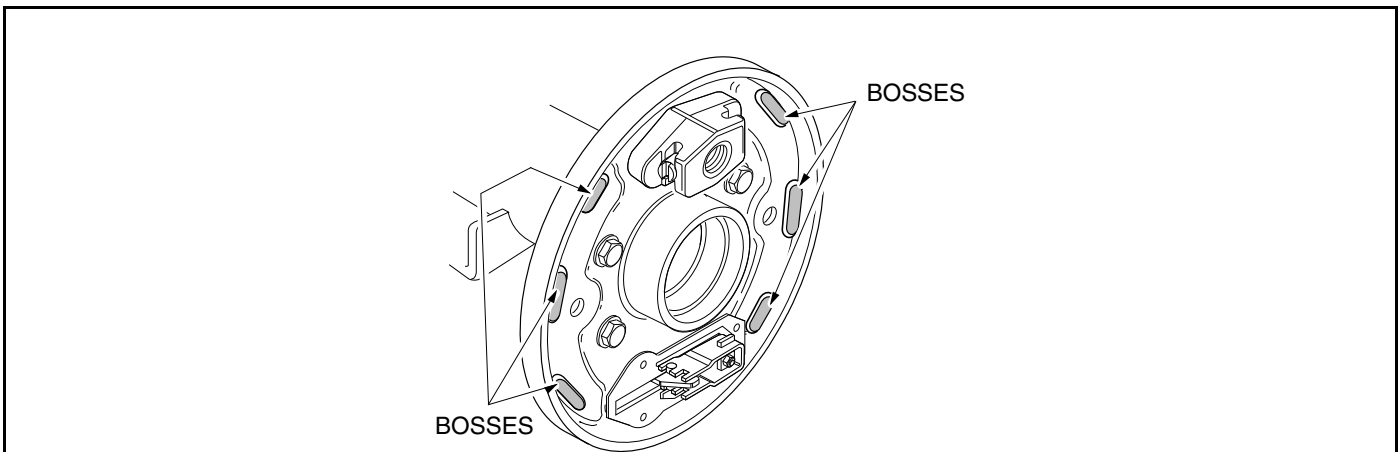

2817

**Figure 6-6 Lubricate Raised Bosses**

5. Use a small brush to carefully apply a light coat of white lithium NLGI #2 grease (Dow Corning BR2-Plus or equivalent) to each end of both brake shoes and into the slots in the brake shoe mounting block as shown (**Figure 6-7, Page 6-4**). **See preceding WARNING.**

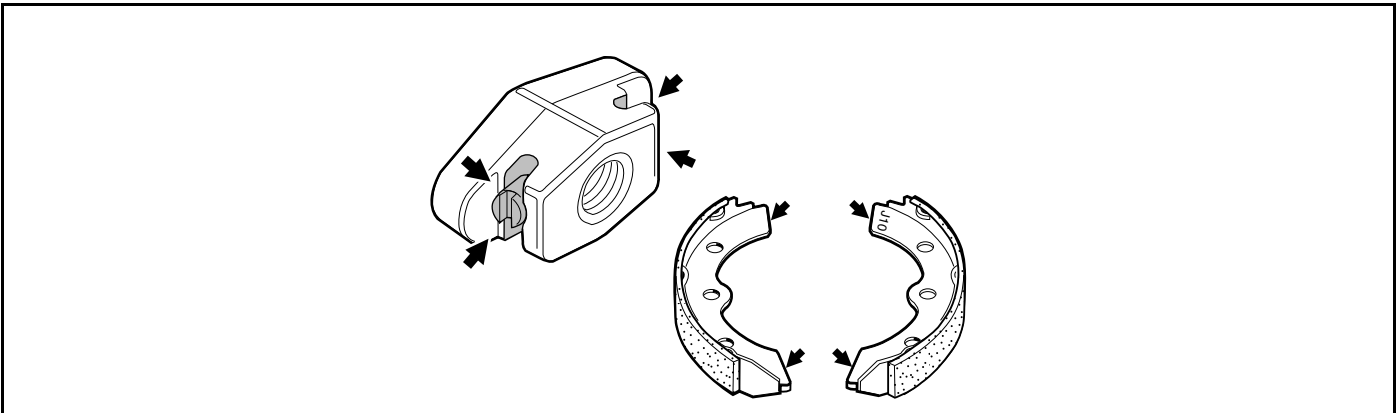

2819

**Figure 6-7 Lubricate Shoes**

6. Use a small brush to carefully apply a light coat of white lithium NLGI #2 grease (Dow Corning BR2-Plus or equivalent) to the brake actuator assembly as shown (**Figure 6-8, Page 6-5**). See preceding **WARNING**.

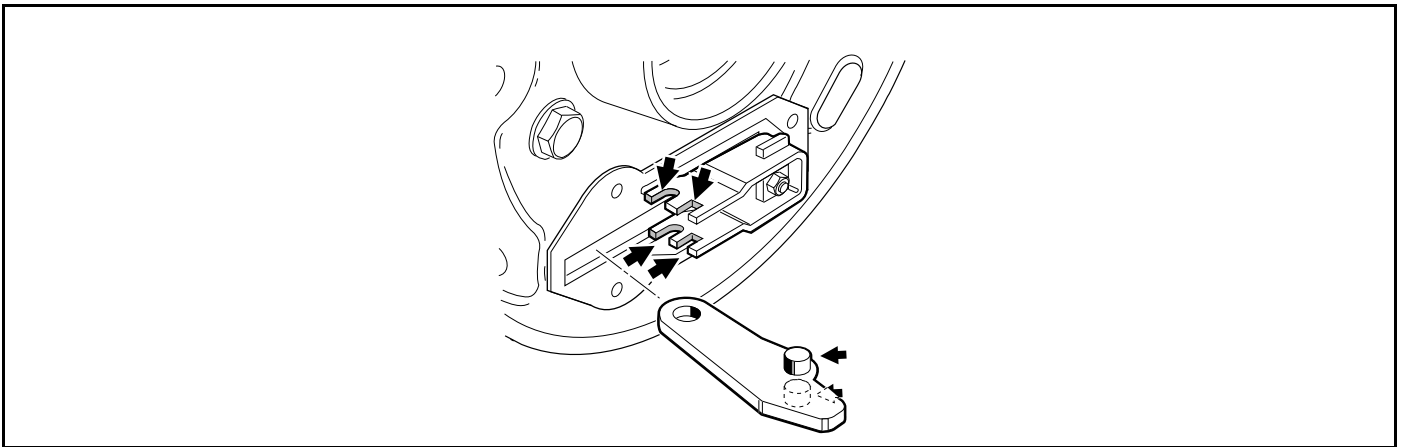

2799

**Figure 6-8** Lubricate Actuator

## BRAKE SHOE INSTALLATION

See General Warnings on page 1-1. See also Asbestos Dust Warning on page 6-1.

**NOTE:** Components of the front wheel brake assembly are identical to the rear wheel manually-adjusted brake assembly. The front brake assembly is rotated 90° (when compared to the rear brake assembly) so the adjusting bolt on each assembly is oriented to the rear of the vehicle rather than at the top of the assembly (Figure 6-21, Page 6-15).

1. Position one shoe in the slots in the mounting block anchor piston and brake actuator (Figure 6-12, Page 6-7). See following **WARNING**.

### **▲ WARNING**

- When installing brake shoes, the shoes must be oriented with tips stamped J10 inserted into the mounting block anchor piston slots rather than into the brake actuator slots (Figure 6-12, Page 6-7). Incorrectly installed brake shoes will be too tight and make adjustment of the brake impossible.
2. Install the shoe retainer clip, using pliers to compress the clip (1) while turning the retainer pin (2) into position (Figure 6-10, Page 6-6).
  3. Attach the springs (with hooks pointing outwards) onto the trailing shoe already installed. Then hold the leading shoe next to the trailing shoe, correctly oriented, and attach the springs to it (Figure 6-11, Page 6-7).

**NOTE:** With brake shoe tips marked J10 oriented to the mounting block, the stamping will be visible on one shoe only. The other J10 stamping will be facing the backing plate and will not be visible.

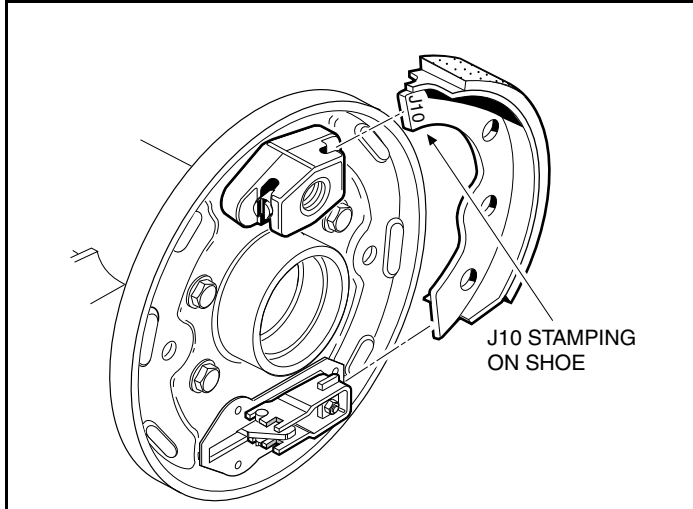

2807

Figure 6-9 Position Shoes

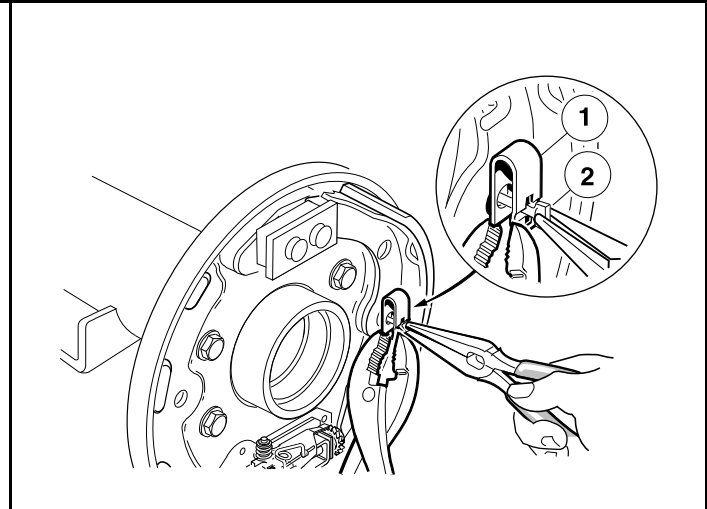

644

Figure 6-10 Retainer Clip

4. While maintaining spring attachment on both shoes, position tips of the second shoe (1) in the mounting slots and then push shoe into place. Hold shoe in position and install retaining clip.
5. After the shoes are installed, move them together up and down and side to side to make sure that they will easily slide approximately 1/4 inch to 3/8 inch (6.3 mm to 9.5 mm) without binding. Make sure the shoes are positioned vertically so the tips of the shoes are positioned flush with the top surface of the shoe mounting blocks as shown in (Figure 6-11, Page 6-7). See following **CAUTION**.

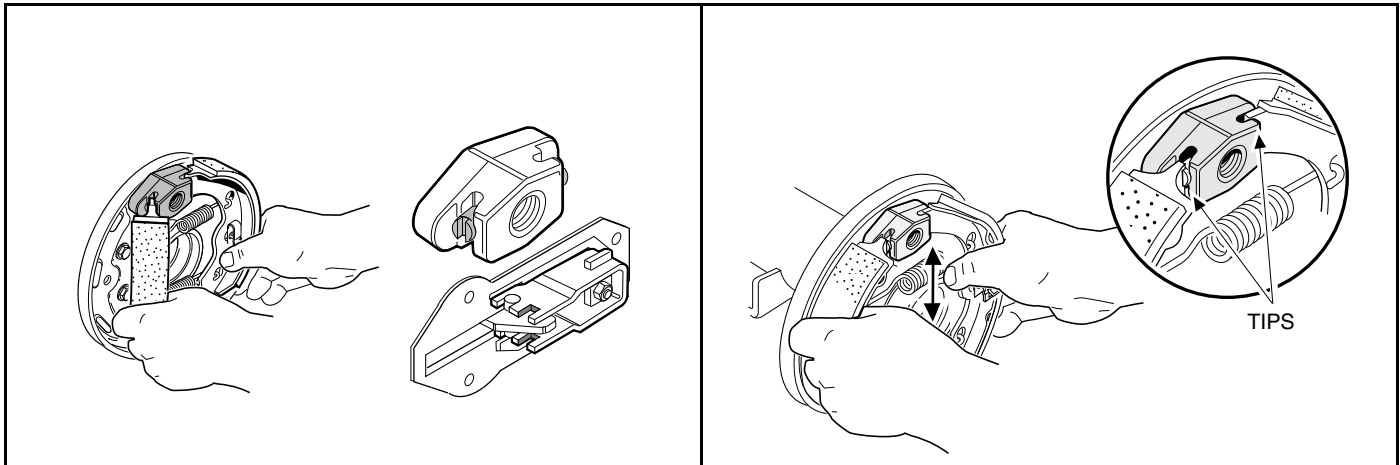

2808

Figure 6-11 Insert Shoes

2800

Figure 6-12 Position Shoes

## CAUTION

- Clean any residual oil from the exposed end of the axle shaft and from the oil seal area prior to installing the axle shaft.

6. For electric vehicles: Install the axle shaft.

For gasoline vehicles: Install the wheel hub assembly. See **Rear Hub Installation, Section 17, Page 17-4.**

7. Install the brake drum and make sure that it is properly seated. See following NOTE.

**NOTE:** If drum installation is difficult, the brake shoes may need to be adjusted vertically in the mounting slots.

8. After the drum is installed, make sure the axle and drum turn freely.

## BRAKE ADJUSTMENT

See General Warnings on page 1-1. See also Asbestos Dust Warning on page 6-1.

## CAUTION

- Pedal group adjustment must be within specifications prior to beginning brake adjustment. Perform the appropriate pedal group adjustment.
- For gasoline vehicles, refer to Pedal Group Adjustment on page 5-7.

**NOTE:** All brake cluster components must be clean, lubricated, and in good working condition prior to beginning brake adjustment.

All wheels must be installed on the vehicle and lug nuts tightened to 65 ft·lb (88 N·m).

## BRAKE CLUSTER ADJUSTMENT

1. Chock the wheels.

2. To provide slack in the brake cables, loosen the equalizer retaining nuts (1 and 5) on the equalizer rod (2) (Figure 6-13, Page 6-8).
3. Loosen the front brake equalizer rod (Figure 6-14, Page 6-8).

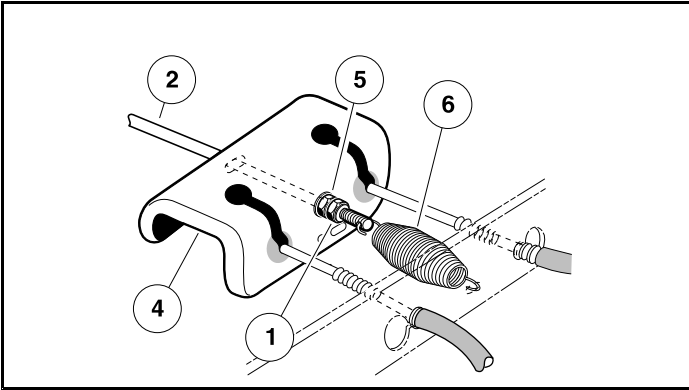

2801

Figure 6-13 Rear Equalizer Adjustment

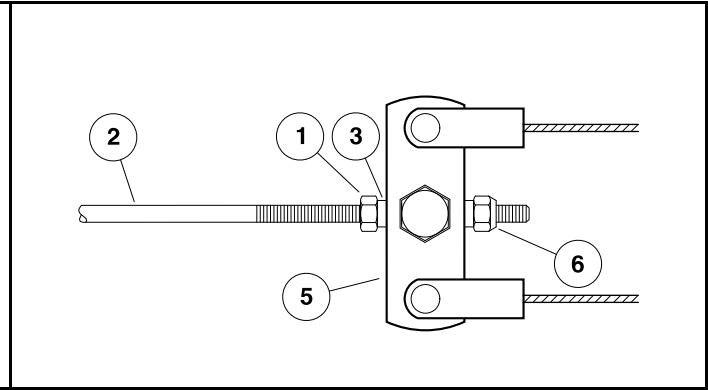

2802

Figure 6-14 Front Equalizer Adjustment

4. Remove the dust cover (4) on the left and right rear brake cluster assemblies (Figure 6-15, Page 6-8).

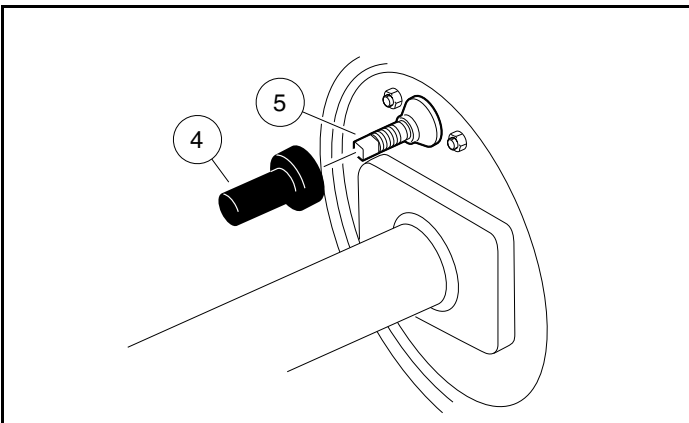

2804

Figure 6-15 Rear Brake Adjustment Bolt

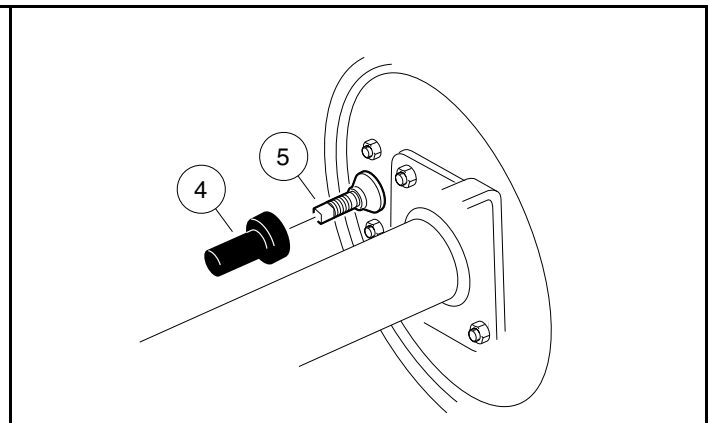

2803

Figure 6-16 Front Brake Adjustment Bolt

5. Use a torque wrench and a 7 mm 8-point socket or Club Car brake adjustment tool to turn the brake adjustment bolt (5) on each brake clockwise until it is tightened to 15 ft·lb (20.3 N·m) then back off 5 clicks. **See following NOTE.**

**NOTE:** If a wheel can still be turned by hand after step 4, inspect the brake clusters and clean and/or replace all parts that do not work properly.

6. Repeat procedure at front brake clusters.



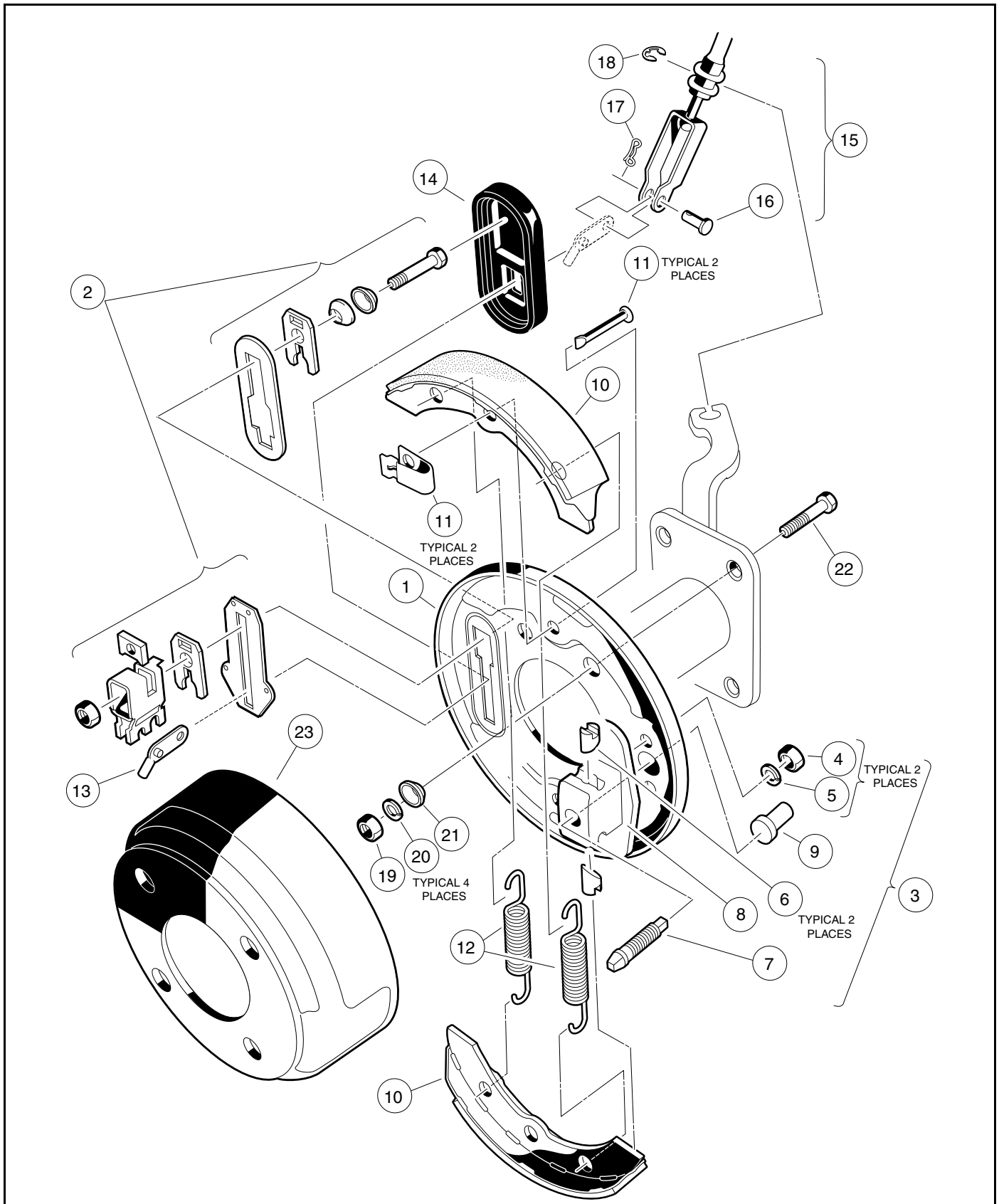

2806

Figure 6-17 Front Manually Adjusted Brake Assembly

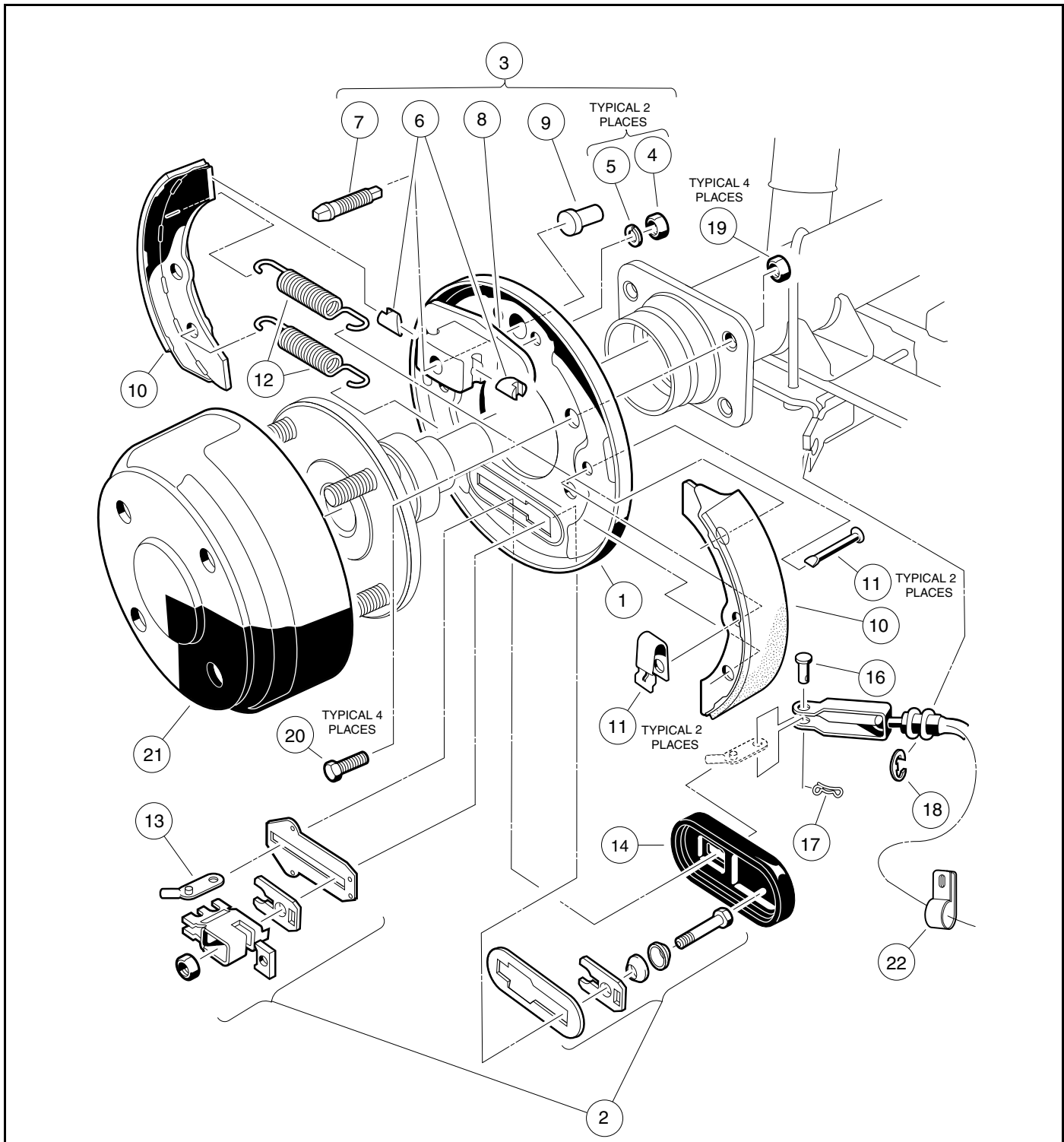

2903

Figure 6-18 Rear Manually-Adjusted Brake Assembly

## BRAKE CABLE EQUALIZATION

1. Set park brake in the third tooth of the ratchet. Place a wedge between the park brake pedal and brake pedal to prevent the park brake from disengaging while equalizing the brake cables (**Figure 6-19, Page 6-11**).

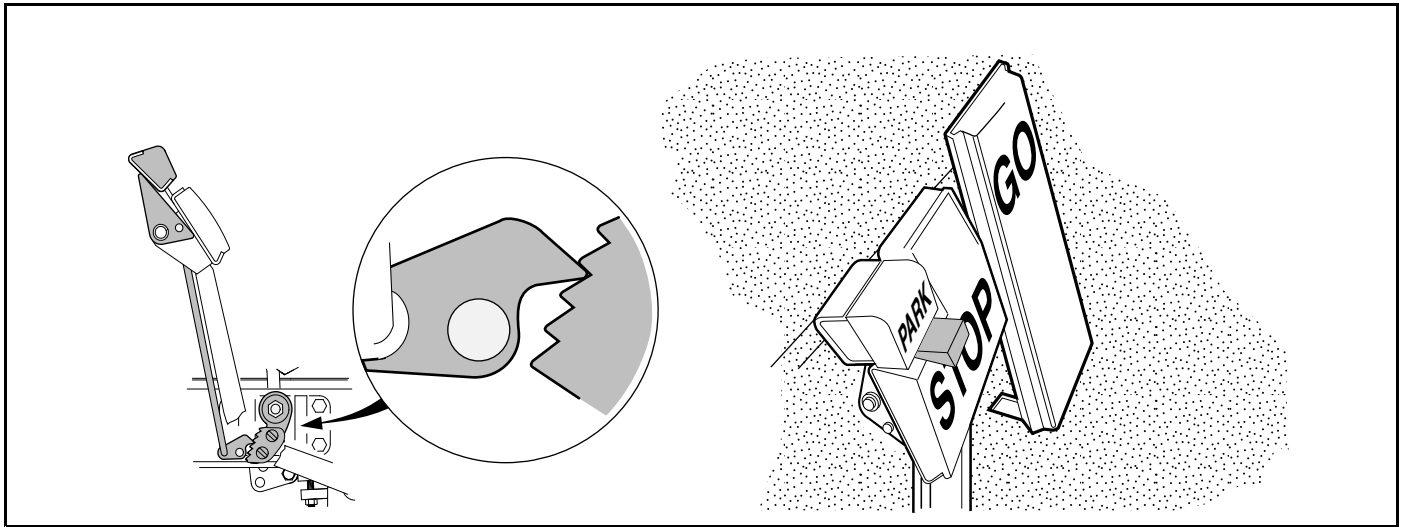

2809

Figure 6-19 Set Park Brake and Insert Wedge

2. Equalize the brake cables.
  - 2.1. Tighten the nylon lock nut (6) on the front equalizer rod (2) to 35 in·lb (4 N·m) (Figure 6-14, Page 6-8).
  - 2.2. Tighten the jam nut (5) on the rear equalizer rod (2) clockwise to 35 in·lb (4 N·m) (Figure 6-13, Page 6-8).
  - 2.3. Repeat steps 3 and 4 until the nuts remain on the torque setting.
  - 2.4. Hold the lock nut (6) on the front equalizer rod (2) in place with a wrench and tighten the jam nut (1) to 13 ft·lb (17.6 N·m) (Figure 6-14, Page 6-8).
  - 2.5. Hold the jam nut (5) on the rear equalizer rod (2) in place with a wrench and tighten the lock nut (1) to 13 ft·lb (17.6 N·m) (Figure 6-13, Page 6-8). See following CAUTION.

## CAUTION

- If the brake pedal return spring (6) was disconnected while equalizing the brake cables, be sure to reconnect it before proceeding (Figure 6-13, Page 6-8).

## FINAL BRAKE CLUSTER ADJUSTMENT

1. To adjust the brake shoes, turn the adjustment bolt counterclockwise five clicks.
2. Repeat step 1 at other brake cluster(s).
3. Install the rubber dust covers (4) over the brake adjustment bolts (5) (Figure 6-15, Page 6-8) and (Figure 6-16, Page 6-8).
4. Carefully support the vehicle with the lifting device, remove jack stands and lower the vehicle to the ground.

## TEST DRIVE VEHICLE

1. With the vehicle on a level surface, release the park brake and push the vehicle by hand. If brake drag exists, readjust cable tension and brakes. See Brake Cable Equalization on page 6-10. See Final Brake Cluster Adjustment on page 6-11.
2. Pedal free play should be less than 1 inch (2.5 cm). If free play exceeds 1 inch (2.5 cm), check pedal group adjustment, and readjust cable tension and brakes. See Brake Cable Equalization on page 6-10. See Final Brake Cluster Adjustment on page 6-11. See following NOTE.

**NOTE:** Brake pedal free play is the distance the brake pedal can be pressed before the brake actuator arm (at the brake cluster) moves.

3. Test drive vehicle. Be sure the brakes function properly. When brake pedal is fully pressed under moderate pressure, it should not go more than halfway to floor, and the vehicle should come to a smooth, straight stop. If the brake pedal goes more than halfway to the floor, or if the vehicle swerves or fails to stop, check pedal group adjustment, and readjust cable tension and brakes. **See Brake Cable Equalization on page 6-10. See Final Brake Cluster Adjustment on page 6-11.** Brake adjustment must be maintained so the brake pedal cannot be pressed to the floor under any circumstance.

## BRAKE CLUSTER REMOVAL AND INSTALLATION

---

See General Warnings on page 1-1. See also Asbestos Dust Warning on page 6-1.

### FRONT BRAKE CLUSTER REMOVAL

1. Place chocks at rear wheels, loosen lug nuts on front wheels, and lift the front of the vehicle with a chain hoist or floor jack. Place jack stands under the round tube crossmember of the frame to support vehicle.
2. Release park brake.
3. Loosen the equalizer retaining nuts (1 and 6) on the front equalizer rod (2) to slightly loosen the brake cable (**Figure 6-14, Page 6-8**).
4. Remove the front wheels and then the brake drums.
5. Remove bow-tie pin (17) and clevis pin (16) from brake cable (**Figure 6-21, Page 6-15**) (**Figure 6-20, Page 6-13**).
6. Remove dust cap (6) on hub and bearing assembly.
7. Remove cotter pin (5) and hex nut (7) from spindle shaft (**Figure 6-20, Page 6-13**).
8. Remove hub and bearing assembly from spindle shaft. Remove four bolts (22), cone washers (21), lockwashers (20), and hex nuts (19) that mount the brake cluster to the spindle (**Figure 6-21, Page 6-15**).
9. Remove brake cluster assembly from spindle.

### FRONT BRAKE CLUSTER INSTALLATION

1. Install in reverse order of removal. Use bolts (22), cone washers (21), lock washers (20), and hex nuts (19) to mount brake cluster (**Figure 6-21, Page 6-15**).
2. Tighten bolts to 30 ft·lb (41 N·m). Adjust brakes as previously described in this section. Use new bow-tie pins when reconnecting brake cables.

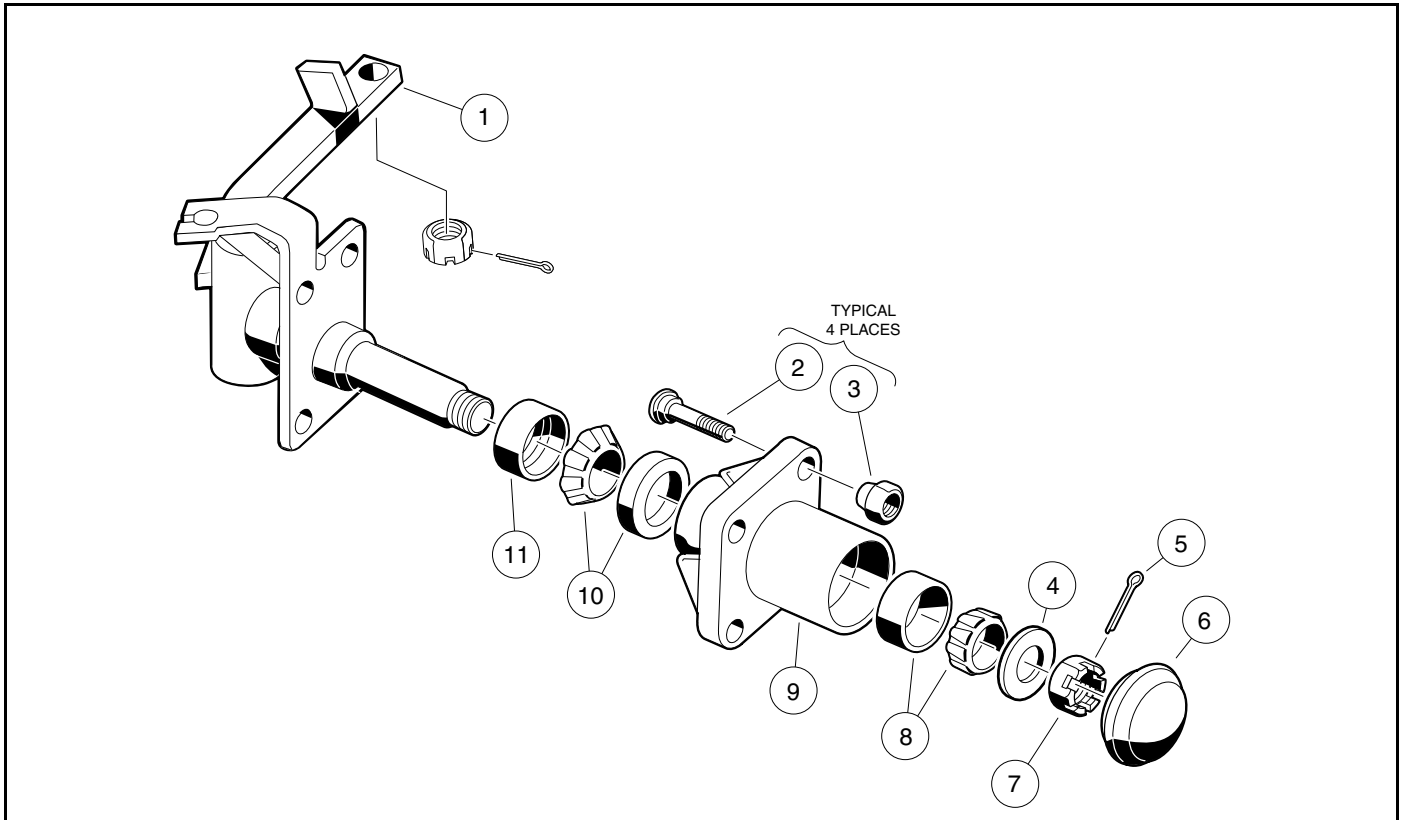

2810

Figure 6-20 Front Spindle Assembly

## REAR BRAKE CLUSTER REMOVAL

1. Place chocks at the front wheels, loosen the lug nuts on the rear wheels and lift the rear of the vehicle with a chain hoist or floor jack. Place jack stands under the axle tubes to support the vehicle.
2. Release park brake and loosen equalizer retaining nuts (1 and 5) on equalizer rod (2) to slightly loosen brake cable (**Figure 6-13, Page 6-8**).
3. Remove the rear wheels and then the brake drums. **See following NOTE.**

**NOTE:** When servicing vehicles with brake drums that cannot be removed by normal methods, perform step 4 of **Brake Shoe Removal on page 6-1**, then continue with this procedure.

4. **For gasoline vehicles:** Remove the wheel hub assembly. **See Rear Hub Removal, Section 17, Page 17-4.**
5. Remove bow-tie pin (17) and clevis pin (16) from brake cable (**Figure 6-18, Page 6-10**).
6. Remove 4 bolts (20) and cone lock nuts (19) that mount the brake cluster to the transaxle (**Figure 6-18, Page 6-10**).
7. Remove rear brake cluster assembly from transaxle.

## REAR BRAKE CLUSTER INSTALLATION

1. Install in reverse order of disassembly. Use new bow tie locking pins when installing brake cables. **See following CAUTION for Electric Vehicles.**

### **⚠ CAUTION**

- Clean any residual oil from the exposed end of the axle tube and from the oil seal area prior to installing the axle shaft.
2. Be sure bolts (20) and new lock nuts (19) are used to mount the brake cluster (**Figure 6-18, Page 6-10**).
  3. Tighten nuts to 17 ft·lb (23.0 N·m). If torquing the bolt heads, torque to 30 ft·lb (40 N·m). **See following WARNING for Electric Vehicles.**

### **⚠ WARNING**

- Be sure retaining ring is properly seated in groove. If ring is not properly installed, axle assembly will separate from transaxle and damage axle assembly and other components. Loss of vehicle control could result in severe personal injury or death.
4. **For electric vehicles:** Install the axle shaft.  
**For gasoline vehicles:** Install the wheel hub assembly. **See Rear Hub Installation, Section 17, Page 17-4.**
  5. Adjust brakes as previously described in this section.

FRONT BRAKE CABLES

See General Warnings on page 1-1. See also Asbestos Dust Warning on page 6-1.

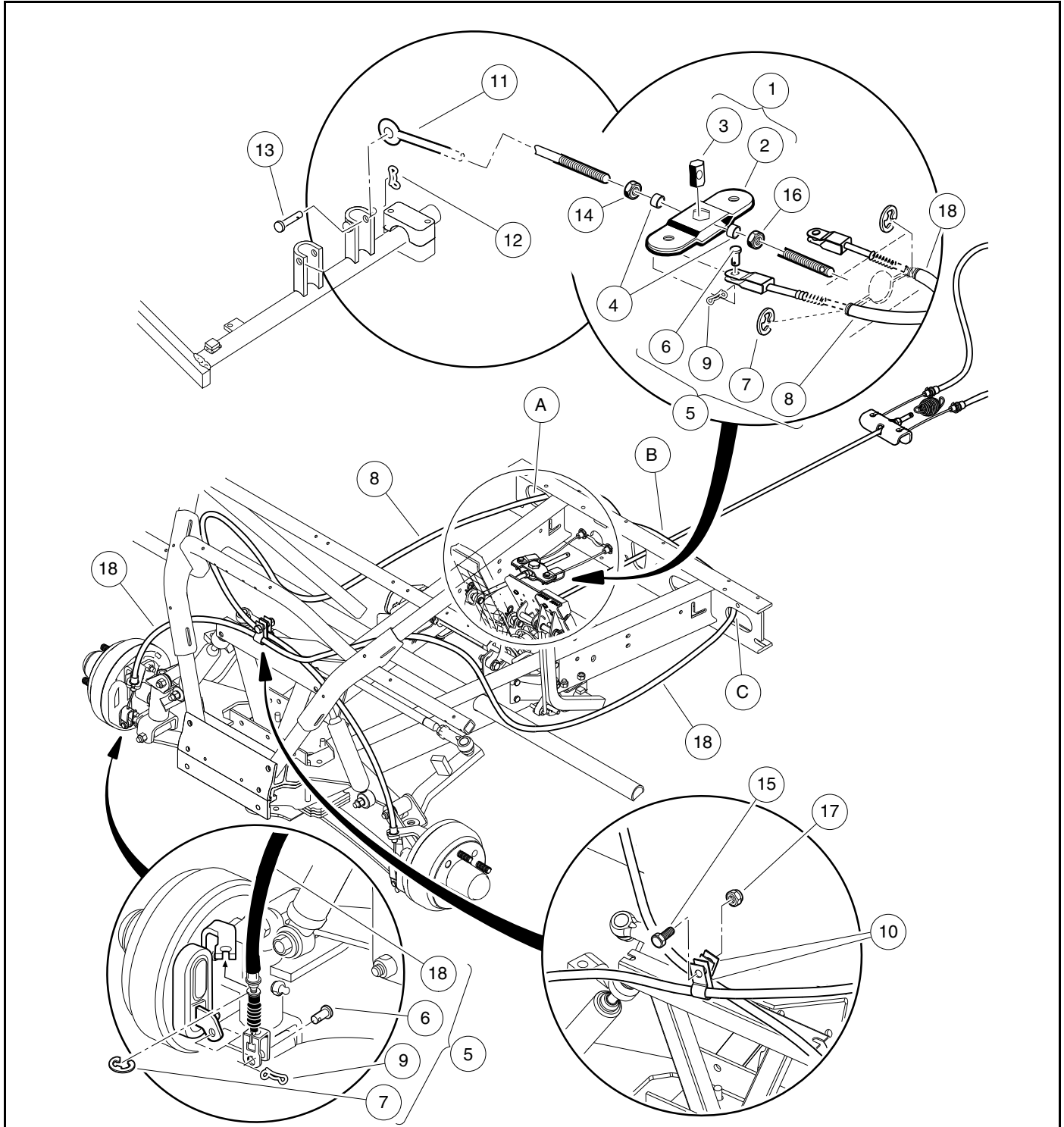

3189

Figure 6-21 Front Brake Cables and Equalizer

## FRONT BRAKE CABLE REMOVAL

1. Remove bow-tie pin (9) and clevis pin (6) from brake lever arm on front brake cluster (**Figure 6-21, Page 6-15**).
2. Remove E-clip (7) from brake cable housing at the front spindle bracket and remove cable (8 or 18) from spindle.
3. Remove bow-tie pin (9), clevis pin (6), and E-clip (7) from brake cable (8 or 18) at equalizer (2).
4. Remove bolt (15) and nut (17) from brake cable clamp (10).
5. Note location and number of wire ties securing brake cable to chassis (**Figure 6-22, Page 6-16**). Cut wire ties and remove front brake cable from vehicle.

## FRONT BRAKE CABLE INSTALLATION

1. Place brake cable (8 or 18) through frame mounting hole behind equalizer (2) and install E-clip (7) on cable housing (**Figure 6-21, Page 6-15**).
2. Attach brake cable clevis to equalizer (2) with clevis pin (6) and new bow-tie pin (9).
3. Route inner cable (8) through slot opening in passenger-side of I-beam (A).
4. Route outer cable (18) over rear brake equalizer rod (B) and through slot opening in driver-side of I-beam (C).
5. Route cables (8 and 18) along inside of frame rails towards front of vehicle (**Figure 6-21, Page 6-15**); through gap between floorboard and tubular crossmember; under cowl frame supports; and crisscross above shock support as shown (**Figure 6-22, Page 6-16**).
6. Secure brake cable clamp (10) with a bolt (15) and nut (17) (**Figure 6-21, Page 6-15**).
7. Attach brake cable (8 or 18) through the front spindle bracket with E-clip (7).
8. Attach brake cable clevis to brake lever arm with clevis pin (6) and a new bow-tie pin (9).
9. At original locations, secure brake cable (8 or 18) to chassis with new wire ties (**Figure 6-22, Page 6-16**).
10. Adjust brakes. **See Brake Adjustment on page 6-7.**

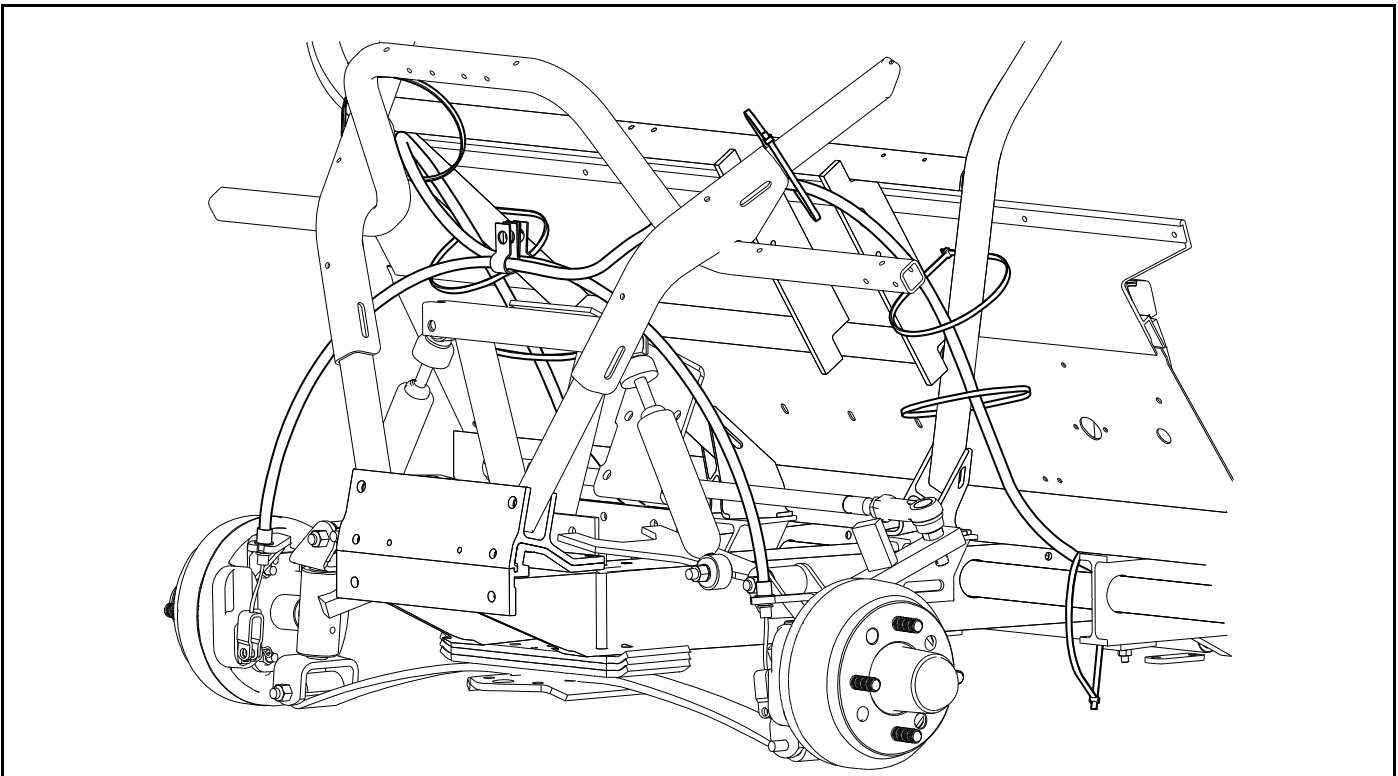

3190

**Figure 6-22 Front Brake Cable Routing Under Cowl and Wire Tie Locations**



---

## REAR BRAKE CABLES

---

### REAR BRAKE CABLE REMOVAL

1. Chock wheels to keep vehicle from unintentionally moving.
2. Release park brake if latched and loosen equalizer retaining nuts (13 and 14) on equalizer rod (2) to slightly loosen brake cables (7) (**Figure 6-23, Page 6-18**).
3. Rotate brake cables (7) upward and pull ends through holes in top of equalizer (3).
4. Disconnect brake cables (7) at rear wheels.
  - 4.1. Remove bow-tie pins (8), clevis pins (5), and E-clips (6) (**Figure 6-23, Page 6-18**).
  - 4.2. Remove cable (7) from plate under leaf spring.
  - 4.3. Note location of hangers (11) and pull cables out of vehicle.

### REAR BRAKE CABLE INSTALLATION

1. Place the cable ends in the equalizer (3) (**Figure 6-23, Page 6-18**). Route cables through hangers (11) in the same manner as the ones removed.
2. At the rear wheel brakes, connect the cables (7) to the brake actuator arms using clevis pins (5) and new bow-tie pins (8).
3. Place cables (7) in plate under leaf springs and secure with E-clips (6).
4. Adjust brakes. **See Brake Adjustment on page 6-7.**

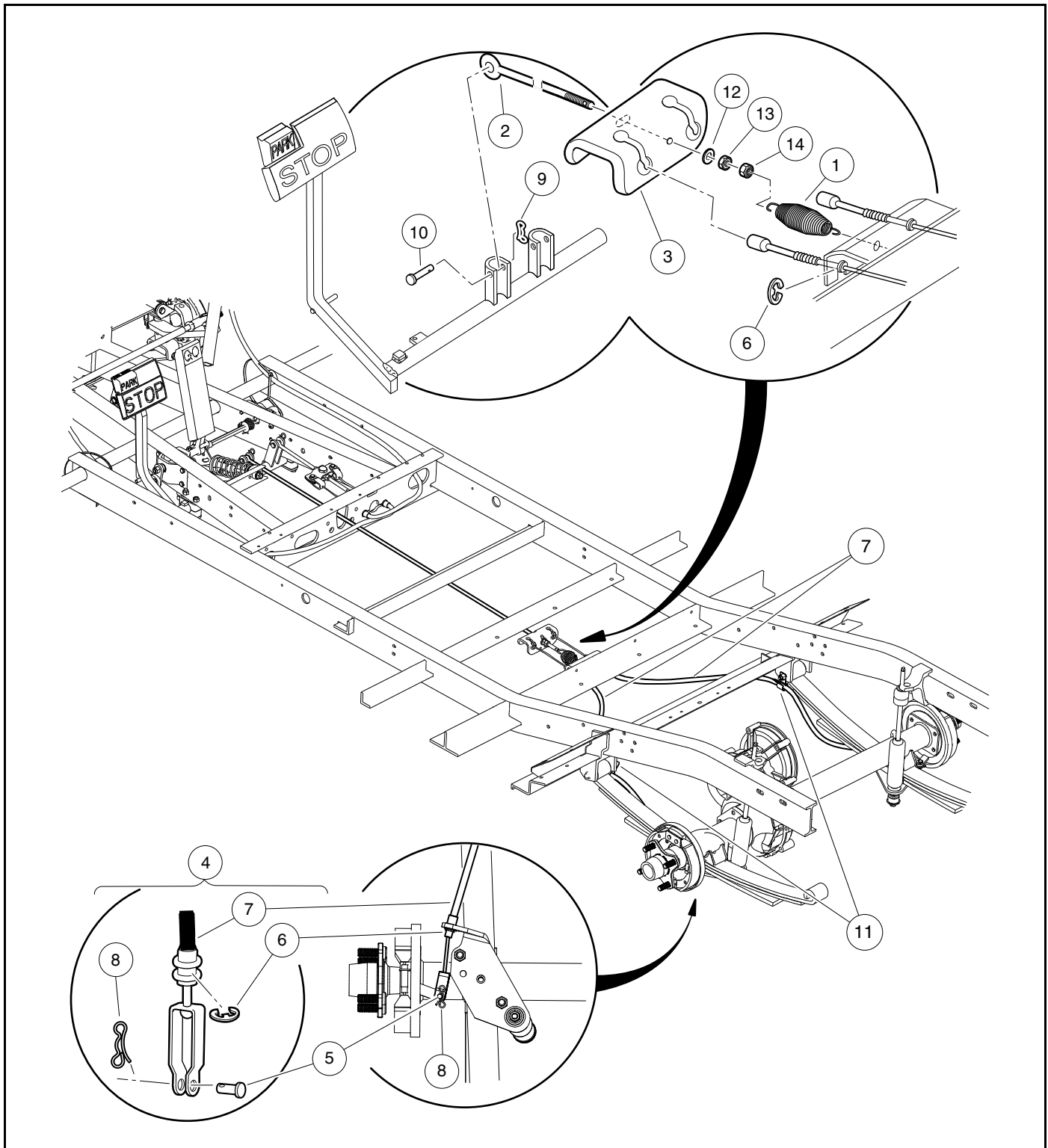

3191

Figure 6-23 Rear Brake Cables and Equalizer

## **⚠ DANGER**

- See General Warnings on page 1-1.

## **⚠ WARNING**

- See General Warnings on page 1-1.

## GENERAL INFORMATION

---

Steering is controlled through a rack and pinion steering assembly that is connected by a steering column to a steering wheel. No manual adjustment to the rack and pinion gear assembly is required. A spring loaded self-adjusting mechanism is incorporated into the assembly.

## STEERING WHEEL

---

See General Warnings on page 1-1.

### STEERING WHEEL REMOVAL

1. Disconnect the battery cables and either discharge the controller or disconnect the spark plug wire(s). **See Disconnecting the Battery-Gasoline Vehicles on page 1-3.**
2. Remove the two mounting screws (1) and plate (2) (**Figure 7-1, Page 7-2**).
3. Match mark the steering wheel (3) and steering column shaft (4) so when the steering wheel is removed it can be placed back in exactly the same position on steering column shaft.
4. Loosen the steering wheel nut (5) and back it off approximately 1/4 inch (6 mm). Do not remove the nut.
5. Use the steering wheel puller to remove steering wheel.
  - 5.1. Place the puller anvil (6) through the top opening of the steering wheel (**Figure 7-2, Page 7-2**).
  - 5.2. Insert the anvil feet through the two slots in the base plate (marked "B") (7) as shown.
  - 5.3. Rotate the anvil screw (8) clockwise until the base plate contacts the bottom of the steering wheel where it attaches to the steering column.
  - 5.4. Use a 1/2-inch drive air impact wrench to tighten the anvil screw (8) until the steering wheel breaks free from the steering shaft.
  - 5.5. Remove the steering wheel puller.
  - 5.6. Remove the steering wheel nut (5) and the steering wheel (3) from the steering column (9) (**Figure 7-1, Page 7-2**).

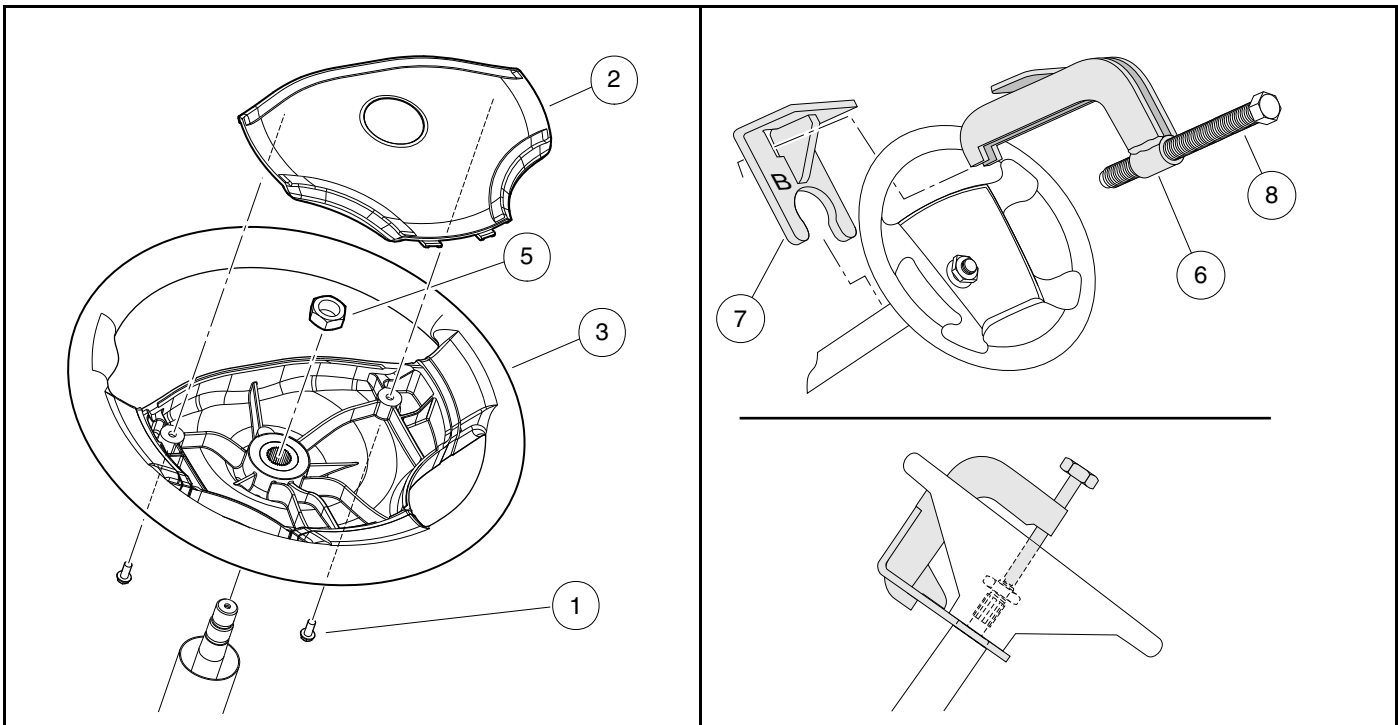

2862

Figure 7-1 Steering Wheel

1500-18300-10253

Figure 7-2 Steering Wheel Puller

## STEERING WHEEL INSTALLATION

**NOTE:** To minimize corrosion and to make future removal of the steering wheel easier, apply a small amount of oil or anti-seize compound to steering shaft splines and taper before installing the steering wheel.

1. Install the steering wheel (3) on the splines of the steering shaft (4). Be sure to align the match marks placed on the wheel and steering column shaft in step 3 above (**Figure 7-1, Page 7-2**).
2. Install the steering wheel nut (5) and tighten to 156 in·lb (17.6 N·m).
3. Install the plate (2) and screws (1) (**Figure 7-1, Page 7-2**). Tighten screws to 16 in·lb (1.8 N·m).
4. Connect the battery cables. **See Connecting the Battery-Gasoline Vehicles on page 1-3.**

# STEERING COLUMN

See General Warnings on page 1-1.

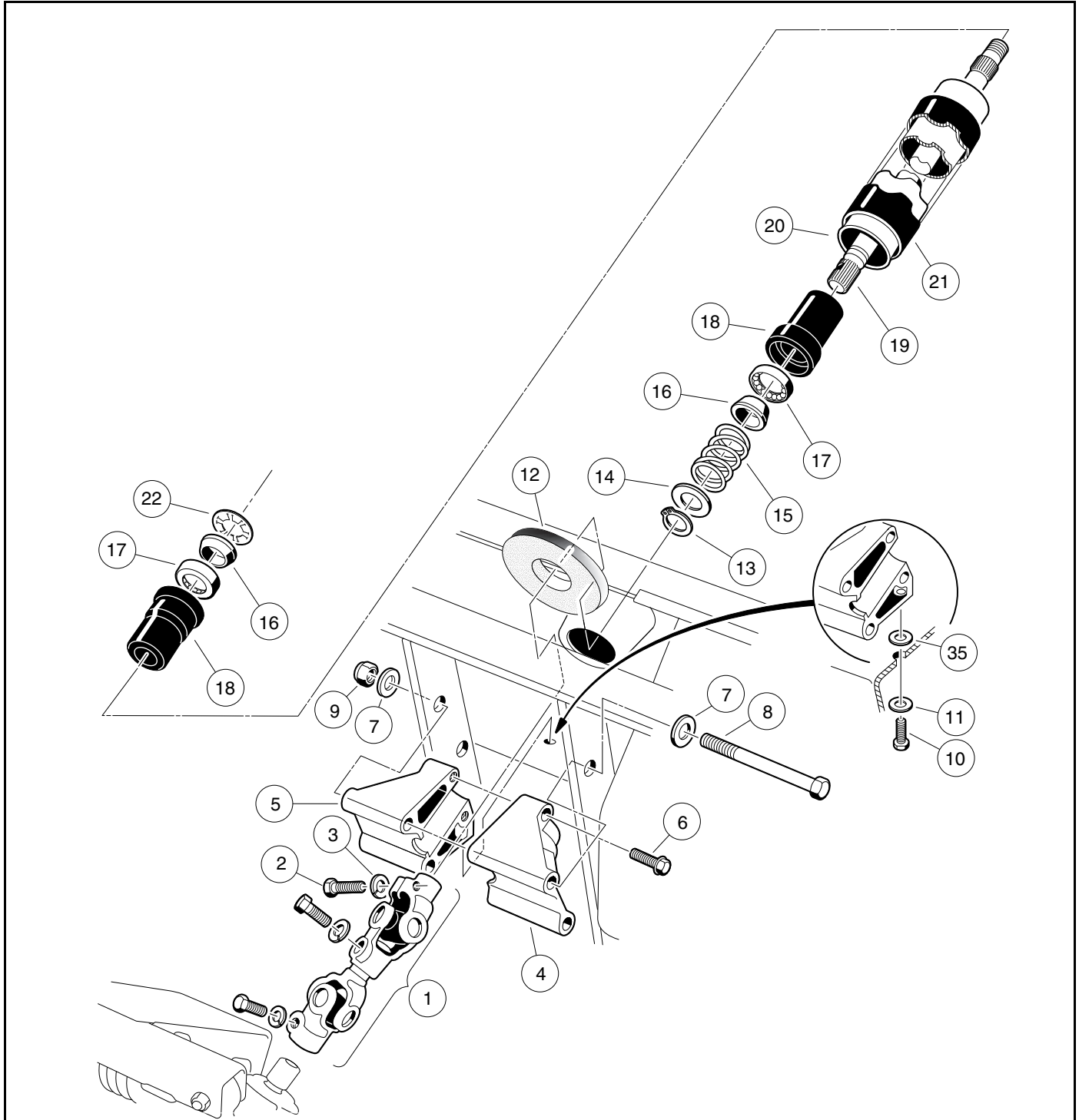

2609

Figure 7-3 Steering Column

## STEERING COLUMN REMOVAL

1. Remove the steering wheel as previously instructed.
2. Remove cowl. **See Cowl Removal, Section 4, Page 4-4.**
3. Remove the upper bolt (2) and lock washer (3) from the universal joint (**Figure 7-3, Page 7-3**).
4. Remove the nuts (9), bolts (8 and 10), and washers (7 and 11) from the steering column mount (4 and 5), (**Figure 7-3, Page 7-3**).
5. Remove the steering column from the vehicle.

## STEERING COLUMN DISASSEMBLY

1. Remove bolts (6) and mounts (4 and 5) from steering column. Remove boot (12) (**Figure 7-3, Page 7-3**).
2. While supporting steering column (20) on a workbench, remove snap ring (13) from shaft. **See following NOTE.**

**NOTE:** Do not allow the steering shaft to slide out of the steering tube when removing the snap ring.

3. Remove the washer (14), spring (15), and wedge (16).
4. Turn the steering column over and slide the shaft out of the tube to expose the retaining ring (22). Use pliers to twist the retaining ring (22) until it breaks off, then remove the wedge (16).
5. Remove the shaft (19) from the bottom of the tube (20).
6. Use steering shaft (19) to push bearing seat (18) out from the opposite end of the steering tube (20).
7. Insert a flat blade screwdriver between the bottom of the outer race of the bearing (17) and the bottom lip of the bearing seat (18) and remove the bearing (17). **See following NOTE.**

**NOTE:** Use new retaining rings and bearings for reassembly.

## STEERING COLUMN ASSEMBLY

1. Insert bearing seat (18) into both ends of steering tube (20). Place a block of wood on bearing seat and tap lightly on block until bearing seat (18) is fully seated in steering tube (20) (**Figure 7-4, Page 7-5**).
2. Press the bearing (17) all the way into the bearing seat (18) using a steering column bearing press tool or a metal tube approximately six inches (15.2 cm) long with a maximum outer diameter of 1-3/16 inches (3.3 cm) and a minimum inside diameter of 7/8 inch (2.2 cm). Be sure the bearing is installed in the bearing seat as shown (**Figure 7-4, Page 7-5**) so the wedge (16) will ride against the inner race of the bearing.
3. Install the wedge (16), spring (15), washer (14), and snap ring (13) onto the bottom end of the steering shaft (19) (**Figure 7-4, Page 7-5**).
4. Insert the shaft (19) from the bottom of the steering tube (20) (**Figure 7-3, Page 7-3**).
5. Turn the assembly over and place the shaft (19) on a bench. Install the wedge (16) and retaining ring (22) onto the top of the shaft. Be sure the prongs on the retaining ring face up and away from the wedge. Use a steering column retaining ring tool to seat the retaining ring to the proper depth. Support end of tube while pressing. If you do not have the recommended tool, use the same tube as was used in step 2 to press the retaining ring onto the top of the shaft. The retaining ring should be pressed onto the shaft until 2 inches to 2-1/8 inches (5.1 cm to 5.4 cm) of the shaft extends from the top of the bearing seat in the steering tube (**Figure 7-5, Page 7-5**).

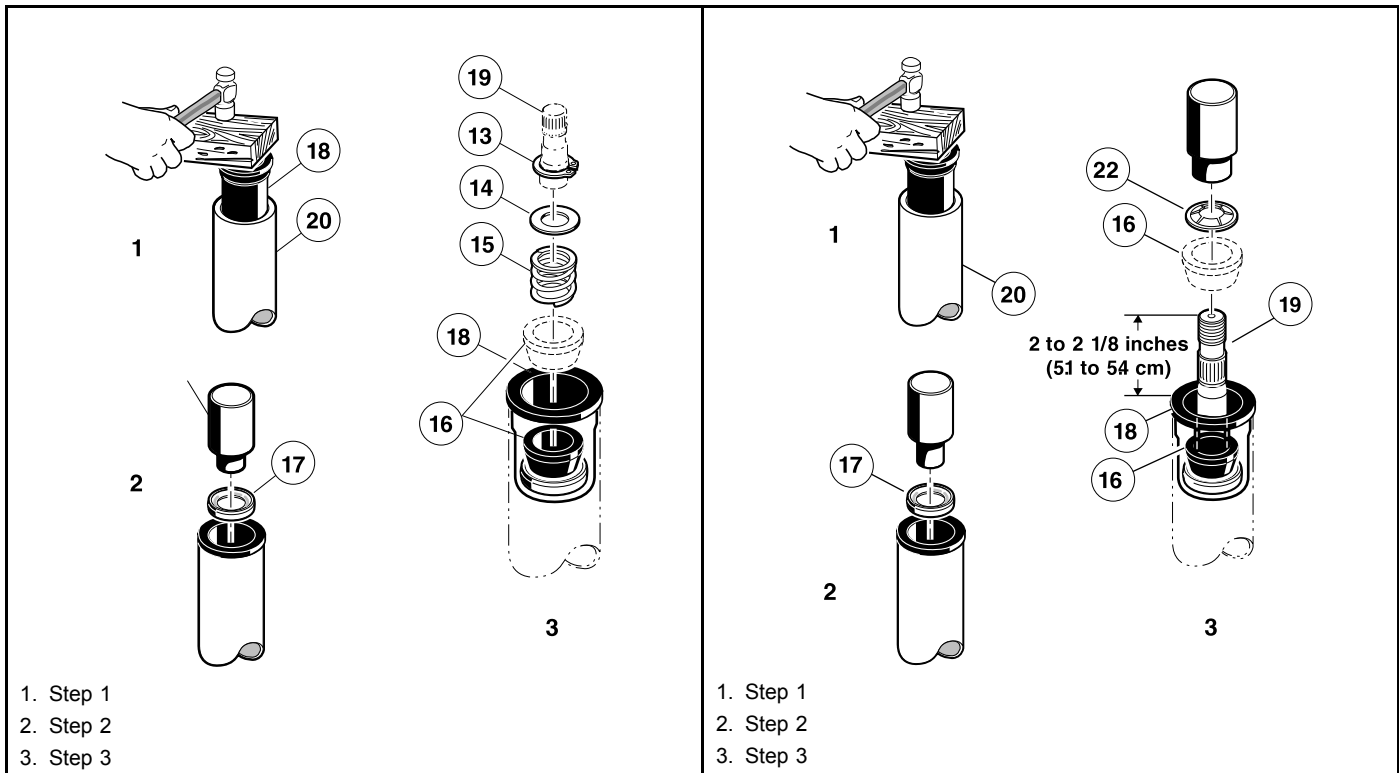

Figure 7-4 Steering Shaft – Bottom End

Figure 7-5 Steering Shaft – Top End

## STEERING COLUMN INSTALLATION

1. Install boot (12). Reinstall mount (4 and 5) onto the end of the steering column. Tighten bolts (6) to 20 ft·lb (27 N·m) (**Figure 7-3, Page 7-3**).
2. For ease of assembly and to prevent corrosion, apply a light coat of anti-seize or lubricating compound to both splined ends of the steering shaft.
3. Position the steering column assembly in the vehicle while inserting the steering column shaft into the upper universal joint (1). The flat portion of the steering shaft spline (19) must be aligned with the bolt hole in the universal joint (1) before sliding the spline into the universal joint. While holding the steering column in place, attach it to the frame using bolts (8), washers (7), and nuts (9) (**Figure 7-3, Page 7-3**). Thread the nuts onto the bolts but do not tighten them.
4. Install wide washer (35), washer (11) and screw (10). Tighten to 20 ft·lb (27 N·m) (**Figure 7-3, Page 7-3**).
5. Install the bolt (2) and lock washer (3) on the upper universal joint and finger-tighten.
6. Tighten the two nuts (9) and bolts (8) to 18 ft·lb (24.4 N·m) (**Figure 7-3, Page 7-3**).
7. Tighten the bolt (2) on the upper universal joint to 15 ft·lb (20 N·m) (**Figure 7-3, Page 7-3**).
8. Check the other two bolts of the universal joint (1) to ensure that they are properly tightened to 15 ft·lb (20 N·m) (**Figure 7-3, Page 7-3**).
9. Install cowl. **See Cowl Installation, Section 4, Page 4-4.**
10. Install the steering wheel. **See Steering Wheel Installation on page 7-2.**

## STEERING ADJUSTMENT

---

See General Warnings on page 1-1.

1. Turn the steering wheel all the way to the right. Note the distance between the passenger side spindle stop (2) and passenger side A-plate (3) (**Figure 7-6, Page 7-8**). The internal stop on the rack must reach its limit of travel against rack and pinion housing at exactly the same time the spindle stops against the passenger side A-plate (with vehicle wheels turned to the right). If simultaneous contact occurs, steering is in correct adjustment; proceed to step 4. If simultaneous contact does not occur, proceed to step 2.
2. Loosen the nuts (27 and 29) and turn the drag link (28) (**Figure 7-10, Page 7-10**) to adjust the drag link rod. Adjust the link rod with the steering wheel turned all the way to the right, so the passenger side spindle stop lightly touches the passenger side A-plate. The internal stop on the rack must reach its limit of travel at the same time the spindle stops against the passenger side A-plate (with vehicle wheels turned to the right). **See following CAUTION.**

### **CAUTION**

---

- **The drag link has both left and right-hand threads. The end of the drag link toward the spindle has left-hand threads, and the end toward the rack has right-hand threads. To prevent damage to threaded parts, care should be taken when servicing the drag link.**
3. When all adjustments have been completed, tighten the nuts (27 and 29) on the drag link assembly with an open end wrench. Tighten nuts to 21 ft·lb (28.4 N·m) (**Figure 7-10, Page 7-10**). **See following CAUTION.**

### **CAUTION**

---

- **When tightening the nuts (27 and 29), make sure the drag link (28) does not turn (Figure 7-10, Page 7-10).**
4. Straighten wheels and turn steering wheel from lock to lock. Wheels should turn smoothly and easily. If steering wheel does not turn smoothly and easily, inspect steering assemblies as follows:
    - ball joints (23) (**Figure 7-10, Page 7-10**) and (6 and 13) (**Figure 7-18, Page 7-18**)
    - spindle bushings (3 and 4) (**Figure 7-19, Page 7-19**)
    - wave washers (20) (**Figure 7-19, Page 7-19**)
    - rack assembly (17) (**Figure 7-10, Page 7-10**)
  5. Also inspect front suspension assemblies as follows:
    - A-plates (1) (**Figure 7-18, Page 7-18**)
    - urethane bushings (2) (**Figure 7-18, Page 7-18**)
    - leaf springs (6) (**Figure 7-19, Page 7-19**)
  6. Replace components as necessary.



---

## RACK AND PINION

---

See General Warnings on page 1-1.

### **CAUTION**

- **Front impacts that bend tie rods and/or drag links can possibly damage internal steering gear components. See Rack and Pinion Inspection on page 7-7. The manufacturer recommends inspecting the rack and pinion and replacing if damaged.**

### **RACK AND PINION INSPECTION**

1. Look for obvious damage to the chassis, where the rack and pinion is mounted, and the rack and pinion housing. Particularly check the housing for broken mounting points.
2. Compare the toe-in against the specification. **See Toe-in Adjustment on page 7-16.**
3. If obvious visible damage is found, such as a bent tie rod, check the steering gear for abnormal free-play, noise, binding or clunking while it is under a load. With the steering system fully assembled and all four tires on the ground/floor, turn the steering wheel from stop to stop. While turning, feel for any binding, clunking or tight/loose spots. Listen for unusual noises. Replace the rack and pinion as an assembly if any is found.
4. In the event of an known impact and obvious visible damage is not found in the method described above, disconnect the tie rods and/or drag links from the spindles. Turn the steering wheel from stop to stop. While turning, feel for any binding or tight/loose spots. Listen for unusual noises. Replace the rack and pinion as an assembly if any is found.

### **RACK AND PINION REMOVAL – MAINTENANCE-FREE BALL JOINTS**

1. Remove the front body. **See Front Body, Section 4, Page 4-2.**
2. Remove the drag link ball joint retaining nut (25) **(Figure 7-10, Page 7-10).**
3. Remove the outer drag link ball joint (23) from the spindle assembly (33) and inspect for excessive wear and seal damage.
4. Remove the bolts (30), washers (31), and lock nuts (32) from the steering rack assembly mounting bracket **(Figure 7-10, Page 7-10).**
5. Remove the bolt (2) and flat washer (3) on the upper universal joint, then remove the rack assembly and universal joint from the vehicle **(Figure 7-3, Page 7-3).**

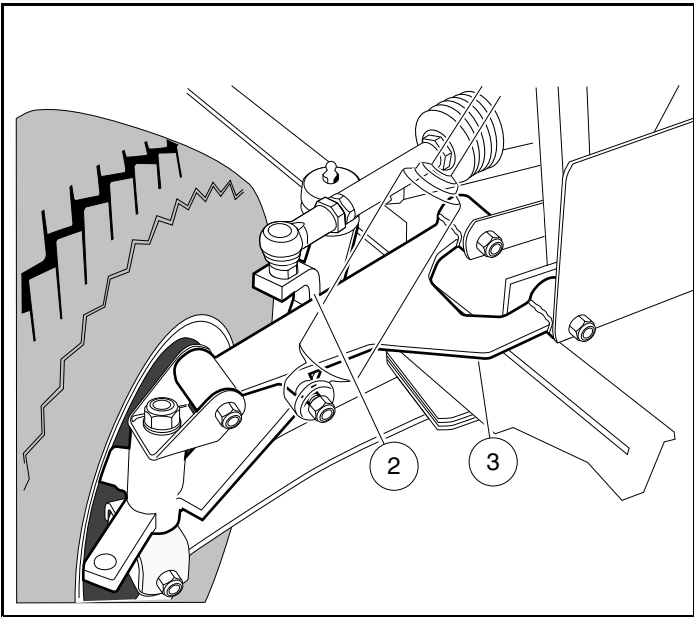

1838

**Figure 7-6 Adjust Steering Alignment**

## RACK AND PINION DISASSEMBLY

### **CAUTION**

- The ball joint (23) (Figure 7-10, Page 7-10) has left-hand threads.
1. Remove ball joint from the spindle and inspect it for excessive wear.
  2. Remove the drag link (28) (Figure 7-10, Page 7-10).
  3. Remove both bellows clamps (2) (plastic wire ties).
  4. Remove the hex nut (29) and slide off the dust seal bellows (1).
  5. Remove the retaining ring (21), then slide off dust seal bellows (20).
  6. Remove the rack screw lock nut (15), rack guide screw (16), rack guide pressure spring (14), and the rack guide (13) (Figure 7-10, Page 7-10).
  7. Remove the universal joint assembly from the pinion (8) by fully removing the bolt and then sliding off the universal joint.

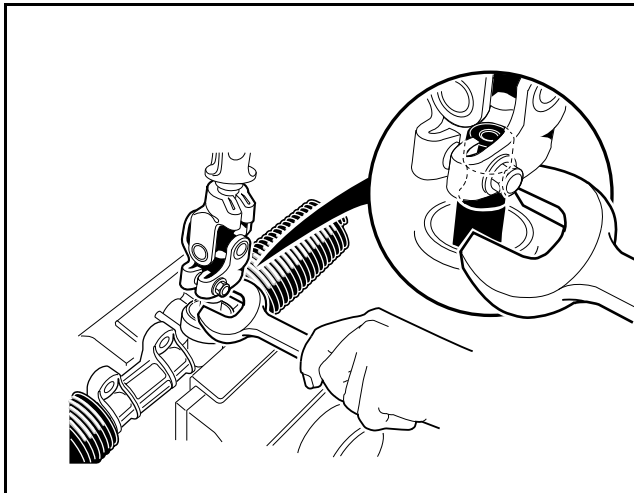

1500-18400-10259

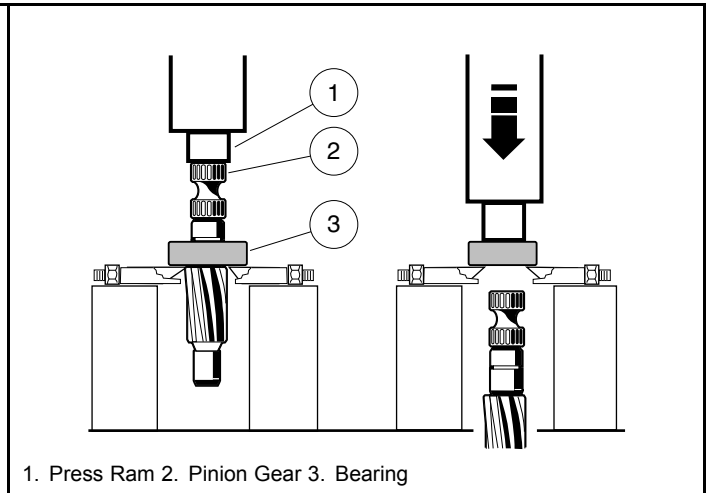
**Figure 7-7 Remove Pinion from Housing**

1. Press Ram 2. Pinion Gear 3. Bearing

1500-18400-10260

**Figure 7-8 Remove Bearing from Pinion**

8. If necessary, remove the dust seal (12). **See following NOTE.**

**NOTE:** If the dust seal (12) is removed, replace with a new one.

9. Use snap ring pliers to remove the internal snap ring (11) (**Figure 7-10, Page 7-10**).
10. Install the universal joint onto the pinion and place a large open end wrench under the universal joint (**Figure 7-7, Page 7-9**). Use the wrench as a lever to pull the pinion from the housing.
11. If the ball bearing (9) has been damaged, remove the external snap ring (10) (**Figure 7-10, Page 7-10**) and press the bearing off (**Figure 7-8, Page 7-9**).
12. Remove retaining ring (19) and stop washer (18), then remove rack (17) from housing (6) (**Figure 7-10, Page 7-10**).
13. If the inner ball joint (3) is excessively worn, remove the ball joint and tab washer (4) from the rack (**Figure 7-9, Page 7-9**).
- 13.1. Secure the rack in a vise using wood blocks (5) between the rack and the jaws of the vise to protect the rack from damage (**Figure 7-9, Page 7-9**).
- 13.2. Loosen and remove the inner ball joint with a wrench.

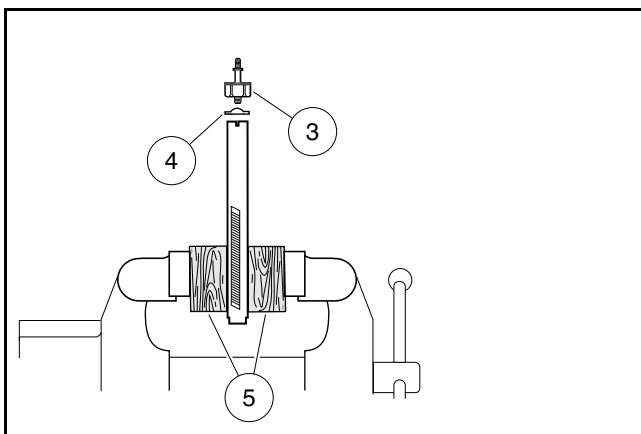

1500-18400-10261

**Figure 7-9 Secure Rack in Vise**

14. Inspect the bushing (5) for excessive wear. If wear is excessive, replace the steering box assembly (**Figure 7-10, Page 7-10**).

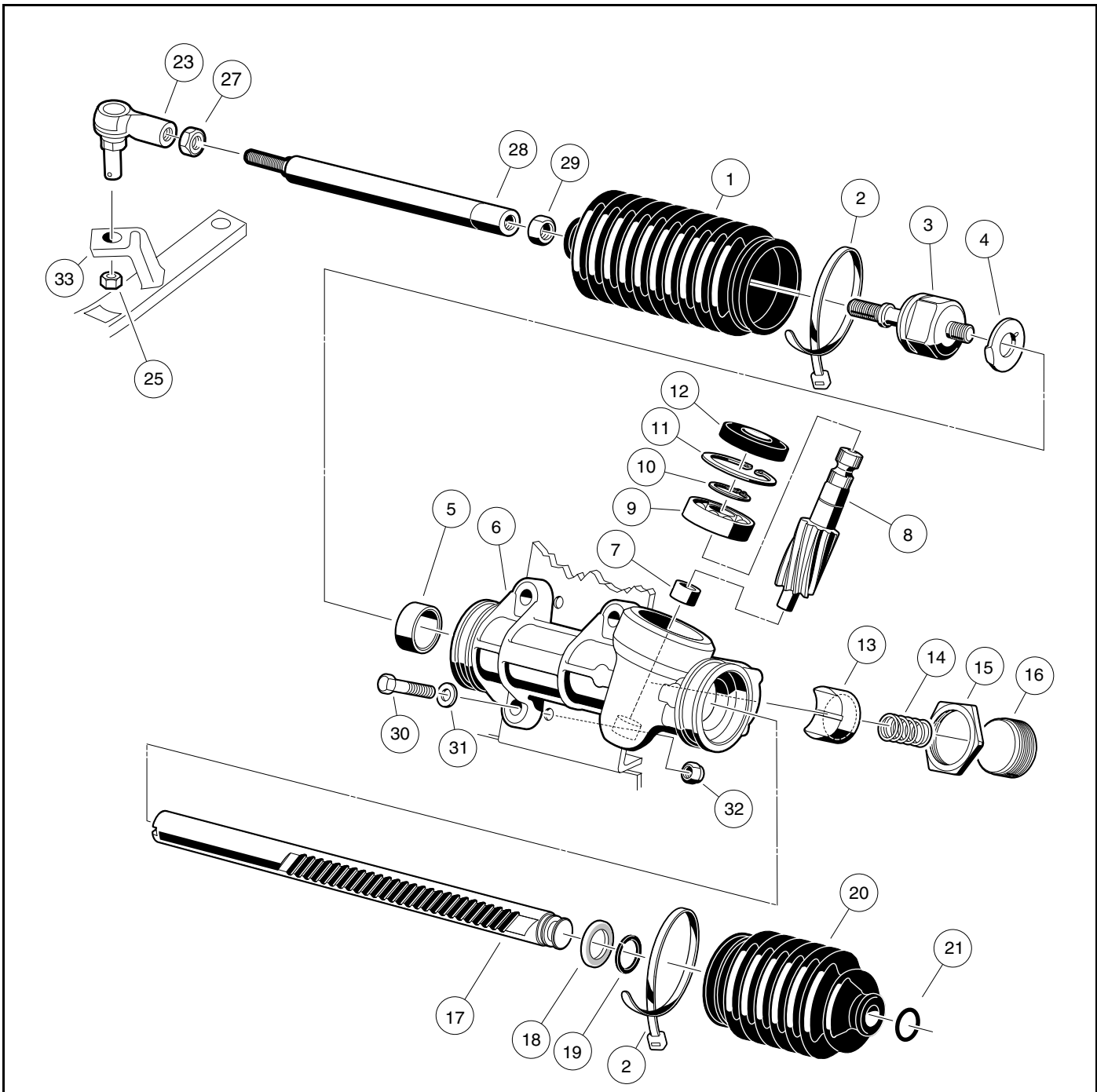

1839

Figure 7-10 Steering Gear – Maintenance-Free Ball Joints

## RACK AND PINION ASSEMBLY

1. Install a new tab washer (4) and an inner ball joint (3) (**Figure 7-9, Page 7-9**). Install the ball joint onto the rack by securing the rack in a vise using wood blocks between the rack and the jaws of the vise to protect the rack from damage. Tighten the ball joint to 60 ft·lb (81 N·m).
2. Bend the edges of the tab washer (4) up against the ball joint (3) (**Figure 7-9, Page 7-9**).

3. Apply a light coating of EP grease to the teeth of the rack (17), then slide the rack through the bushing (5) and housing (6). Install the stop washer (18) and retaining ring (19) to the end of the rack (**Figure 7-10, Page 7-10**).

## **CAUTION**

- In step 4, do not press against the outer race of the bearing.
4. If the bearing (9) was removed, press on a new bearing, exerting all pressure on the inner race (grease the bearing before installing it). Then install the external snap ring (10) (**Figure 7-10, Page 7-10**). **See preceding CAUTION.**
  5. If the needle bearing (7) is damaged, the steering box assembly must be replaced (**Figure 7-10, Page 7-10**).
  6. Install pinion (8) and bearing (9) assembly into the housing (6) (**Figure 7-10, Page 7-10**). Make sure the rack gear teeth will mesh with the gear teeth on the pinion. The rack may need to be rotated slightly while lightly tapping on the pinion-bearing assembly with a rubber mallet. **See following CAUTION.**

## **CAUTION**

- Do not force the pinion-bearing assembly into the housing. The gear teeth or the small bearing could be damaged.

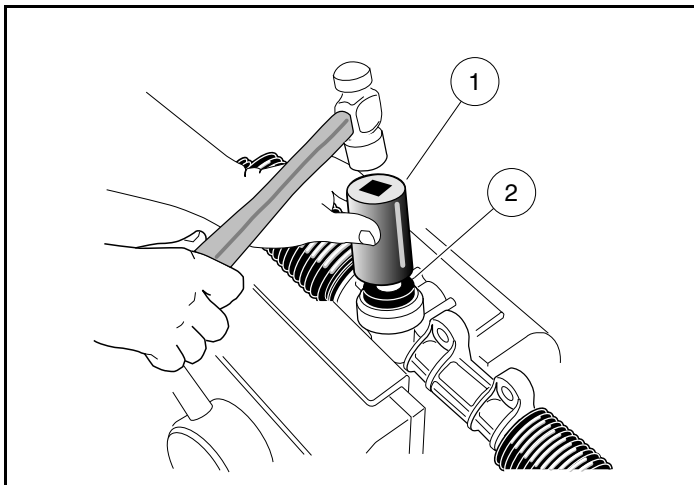

1500-18400-10263

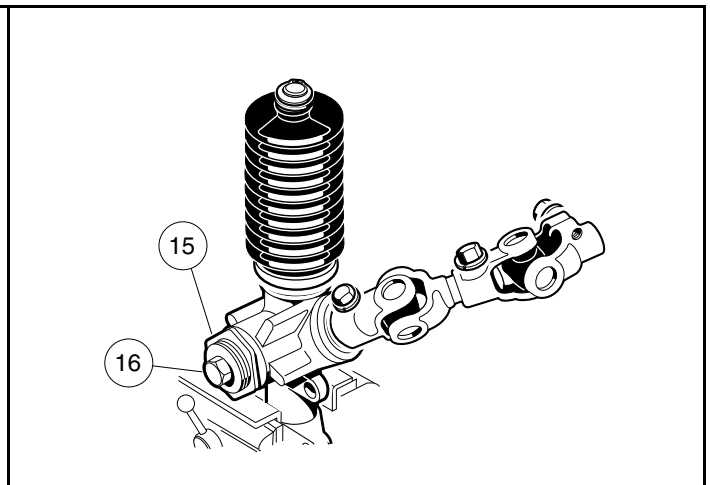
**Figure 7-11 Press In Dust Seal**

1500-18400-10264

**Figure 7-12 Rack and Pinion Adjustment**

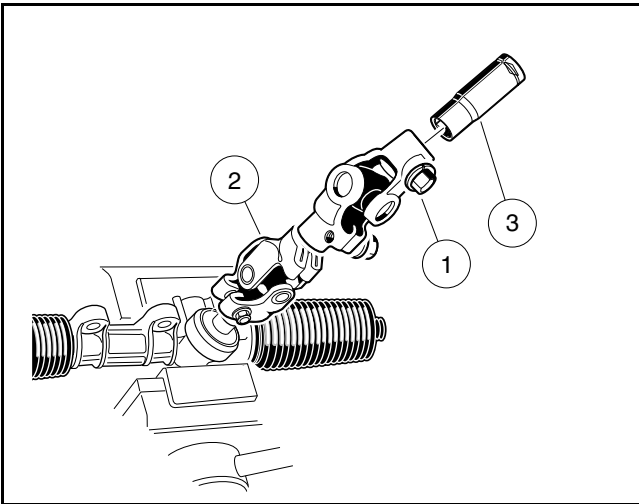

1500-18400-10265

**Figure 7-13 Rack and Pinion Resistance**

7. Install the internal snap ring (11) (**Figure 7-10, Page 7-10**).
8. Using an appropriate size deep well socket (1) to apply pressure evenly, press in a new dust seal (2) (**Figure 7-11, Page 7-11**).
9. Apply a small amount of grease to the rack guide (13) where it comes into contact with the rack (17) (**Figure 7-10, Page 7-10**).
10. Place a few drops of Loctite® 222 to the threads of the screw (16) (**Figure 7-10, Page 7-10**).
11. Install the rack guide (13), pressure spring (14), and screw (16). The screw should be threaded in until a rotational torque of 10 in·lb (1.13 N·m) is achieved (**Figure 7-10, Page 7-10**).
- 11.1. Reposition the rack and pinion in a vise.
- 11.2. Insert a 3/8-inch deep well socket (3) into the steering column end of the universal joint (2) and tighten the bolt (1) to 15 ft·lb (20.3 N·m) (**Figure 7-13, Page 7-12**).
- 11.3. Use a torque wrench connected to the 3/8-inch deep well socket (3) to measure the resistance of the rack and pinion. Rotational resistance should measure 7 to 15 in·lb (0.8 to 1.7 N·m).
- 11.4. If measured resistance does not equal 7 to 15 in·lb, loosen the lock nut (15) and tighten the screw (16) until it bottoms out, then back the screw off one quarter turn. Tighten the lock nut to 28 ft·lb (38 N·m) (**Figure 7-12, Page 7-11**). **See following NOTE.**

**NOTE:** When tightening the lock nut (15) make sure the screw (16) does not change adjustment (**Figure 7-12, Page 7-11**).

12. Install the dust seal bellows (20) and retaining ring (21) (**Figure 7-10, Page 7-10**).
13. Install the dust seal bellows (1) and hex nut (29) (**Figure 7-10, Page 7-10**).
14. Install the universal joint on the pinion. Tighten the bolt to 15 ft·lb (20 N·m).
15. Install new bellows clamps (wire ties) (2) (**Figure 7-10, Page 7-10**).
16. Install the drag link (28) by fully threading the ground end into the inner ball joint (3). **See following CAUTION.**

## **CAUTION**

- The ball joint (23) (**Figure 7-10, Page 7-10**) has left-hand threads.
  - The tie rod and drag link have right-hand threads on one end and left-hand threads on the other end. Right-hand threads are identified by a groove in the tie rod or drag link.
17. Install the ball joint (23) (**Figure 7-10, Page 7-10**). **See preceding CAUTION.**

**RACK AND PINION INSTALLATION – MAINTENANCE-FREE BALL JOINTS**

1. Position the steering gear box assembly on the shock and gear support and install the bolts (30), washers (31), and nuts (32). Do not tighten the mounting bolts (**Figure 7-10, Page 7-10**).
2. For ease of assembly and to prevent corrosion, apply a light coat of anti-seize and lubricating compound to the splined end of the steering column shaft.
3. Align the flat portion of the steering shaft spline with the bolt hole in the universal joint and then slide the shaft into the upper universal joint. Install the bolt and lock washer on the upper universal joint and tighten it to 15 ft·lb (20 N·m).
4. Tighten the steering rack mounting bolts (30) to 22 ft·lb (29.8 N·m) (**Figure 7-10, Page 7-10**).
5. Install the drag link ball joint (23) on the spindle arm riser (33) and secure with retaining nut (25). Tighten nut to 40 ft·lb (54 N·m).
6. Adjust the steering. **See Steering Adjustment on page 7-6.**

## TIE ROD AND DRAG LINK

---

See General Warnings on page 1-1.

### TIE ROD AND DRAG LINK REMOVAL – MAINTENANCE-FREE BALL JOINTS

1. Using locking pliers to hold tie rod and drag link, loosen jam nuts (7 and 12) on tie rod ball joints (**Figure 7-18, Page 7-18**) and loosen jam nuts (27 and 29) on the drag link (**Figure 7-10, Page 7-10**).
2. Remove the ball joint retaining nuts (20) (**Figure 7-18, Page 7-18**).
3. Remove ball joints (6 and 13) (**Figure 7-18, Page 7-18**) and (23) (**Figure 7-10, Page 7-10**) from the spindles.
4. Remove the ball joints from the tie rod (11) (**Figure 7-18, Page 7-18**).
5. Remove drag link (28) from inner ball joint assembly (3) and drag link ball joint (23) (**Figure 7-10, Page 7-10**).

### TIE ROD AND DRAG LINK INSTALLATION – MAINTENANCE-FREE BALL JOINTS

1. Thread ball joints (6 and 13) into tie rod (11) to a depth of 1/2-inch (12.5 mm) (**Figure 7-18, Page 7-18**). See following **WARNING** and **CAUTION**.

#### **⚠ WARNING**

- The ball joints must be threaded into the rod at least 5/16 of an inch (8 mm). Failure to thread ball joints in deep enough may cause a ball joint to separate from the rod during adjustment or while being operated, possibly resulting in loss of vehicle control and severe personal injury.

#### **CAUTION**

- The tie rod and drag link have right-hand threads on one end and left-hand threads on the other end. Right-hand threads are identified by a groove in the tie rod or drag link.
2. Attach the tie rod ball joints (6 and 13) to the spindle tabs (23), then install and tighten the nuts (20) to 40 ft·lb (54 N·m) (**Figure 7-18, Page 7-18**).
  3. Thread the drag link rod (28) all the way onto the threaded stud of the inner ball joint assembly (3) (right-hand threads) (**Figure 7-10, Page 7-10**).
  4. Thread the ball joint (23) into the drag link rod (28) (left-hand threads) to full thread depth (**Figure 7-10, Page 7-10**).
  5. Install the drag link ball joint (23) on the spindle arm riser (33) and secure with retaining nut (25) (**Figure 7-10, Page 7-10**). Tighten nut to 40 ft·lb (54 N·m).
  6. Adjust camber and toe-in. See **Camber Adjustment** on page 7-15 and **Toe-in Adjustment** on page 7-16.
  7. Adjust steering. See **Steering Adjustment** on page 7-6.



## FRONT SUSPENSION

See General Warnings on page 1-1.

### LUBRICATION

Two grease fittings (one in each spindle housing) are provided. Lubricate these fittings at the recommended interval with the proper lubricant. **See Periodic Lubrication Schedule, Section 10, Page 10-6.**

### WHEEL ALIGNMENT

Wheel alignment is limited to equalizing the camber angle of each front wheel and adjusting toe-in of the front wheels. There is also a drag link adjustment to equalize the turning radius in both directions. **See Steering Adjustment on page 7-6. See following NOTE.**

**NOTE:** Prior to making any front suspension adjustments, inspect components for wear and damage and repair or replace as necessary.

#### Camber Adjustment

1. Check each front wheel with a framing square. At the floor (or ground), there should be an equal amount of space between each tire and the framing square (**Figure 7-14, Page 7-15**).
2. Loosen, but do not remove, the four nuts (32) that secure the leaf spring (6) to the bottom spring plate (29) (**Figure 7-19, Page 7-19**). **See also Figure 7-15, Page 7-15.**

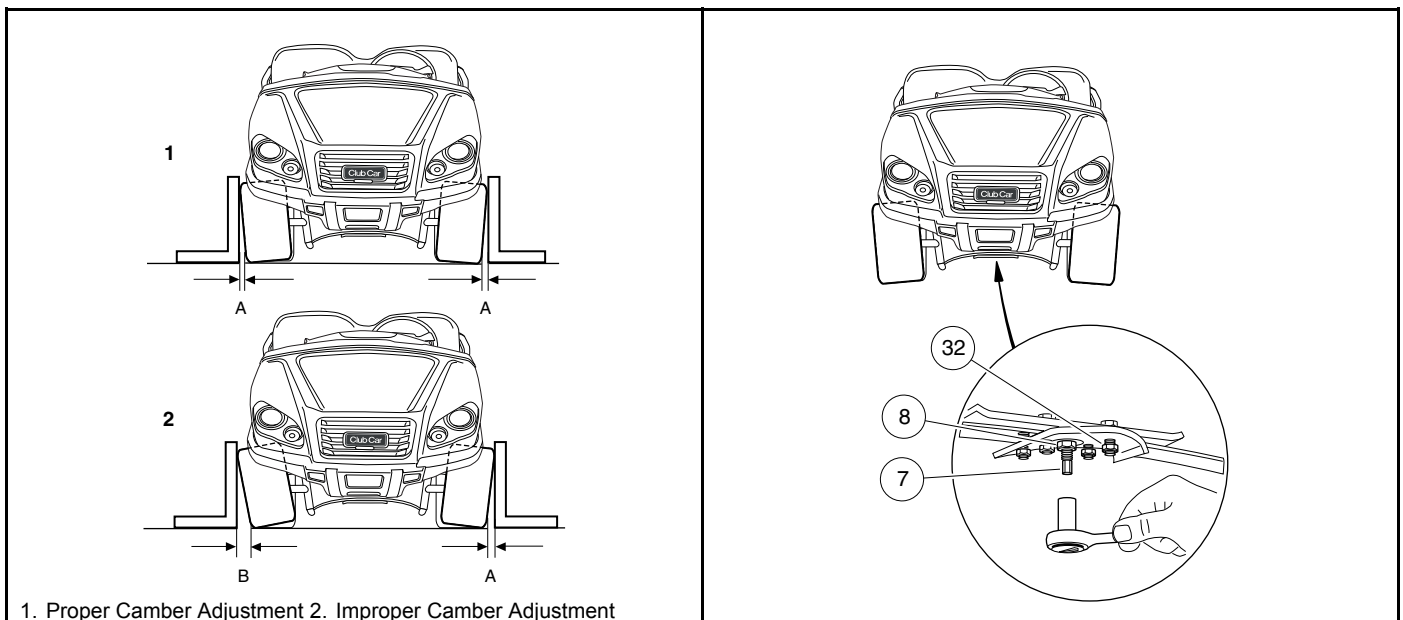

2868

**Figure 7-14 Check Camber**

2869

**Figure 7-15 Adjust Camber**

3. Loosen, but do not remove, the hex nut (8) on the adjustment eccentric (7) (**Figure 7-19, Page 7-19**) in the center of the spring. **See also Figure 7-15, Page 7-15.**
4. Use a 7 mm deep well socket to rotate the eccentric (**Figure 7-15, Page 7-15**).
5. After adjusting camber, tighten the four spring retaining nuts (32) (**Figure 7-19, Page 7-19**) to 23 ft·lb (31 N·m). Then roll the vehicle forward one full tire revolution and recheck the camber. Adjust as required. **See also Figure 7-14, Page 7-15.**

- Tighten the hex nut (8) on the adjustment eccentric (7) to 23 ft·lb (31 N·m) (**Figure 7-19, Page 7-19**). See also **Figure 7-15, Page 7-15**.

### Toe-in Adjustment

- On a level surface, roll the vehicle forward, then stop. Make sure the front wheels are pointed straight ahead. Do not turn the steering wheel again during this procedure.
- On each front tire, mark (as closely as possible) the center of the tread face that is oriented toward the rear of the vehicle. The marks should be even with the bottom surfaces of the vehicle frame I-beams.
- Measure the distance between the marks on the rear-facing surfaces of the tires, and then roll the vehicle **forward** one and a half wheel revolutions until the marks appear on the forward facing surfaces of the tires at about the same height from the floor (**Figure 7-16, Page 7-16**).

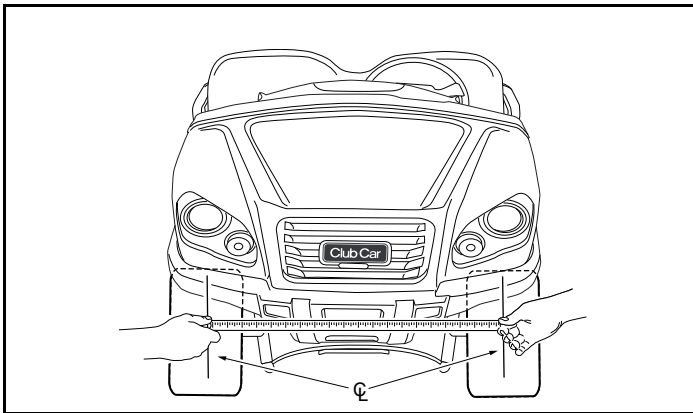

2870

**Figure 7-16 Check Toe-In**

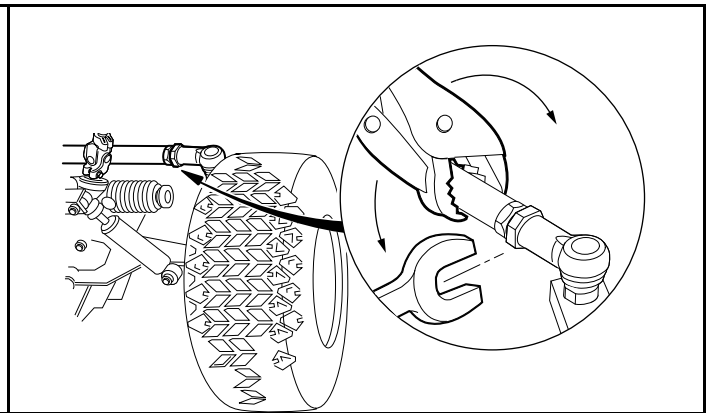

2620

**Figure 7-17 Adjust Toe-In**

- Measure the distance between the marks on the forward-facing surfaces of the tires. **See following NOTE.**

**NOTE:** The front measurement must be less than the rear measurement.

- Subtract the measurement on the front of the tires from the measurement on the rear of the tires. The difference is the toe-in. Proper toe-in is 1/8 to 3/8 of an inch (3.2 to 9.5 mm).
- If adjustment is necessary, loosen the jam nut on each tie rod ball joint and rotate the tie rod to increase or decrease toe-in (**Figure 7-17, Page 7-16**). **See following CAUTION.**

### CAUTION

- The tie rod has right-hand threads on one end and left-hand threads on the other end. Right-hand threads are identified by a groove in the tie rod.

- Tighten nuts (loosened in step 6) to 21 ft·lb (28 N·m) and recheck toe-in.
- After toe-in adjustment is made and with wheels in the straight ahead position, the steering wheel should be at the center of its travel. There should be equal travel to the left and right. **See following NOTE.**

**NOTE:** If the minimum turning radius is not the same for both left and right turns, adjust the steering. **See Steering Adjustment on page 7-6.**

## FRONT SUSPENSION COMPONENTS

---

See General Warnings on page 1-1.

### LEAF SPRING REMOVAL

1. Disconnect the battery cables and either discharge the controller or disconnect the spark plug wire(s). **See Disconnecting the Battery-Gasoline Vehicles on page 1-3.**
2. Remove both front wheels. **See Wheel Removal, Section 8, Page 8-1.**
3. Remove the nuts (14) and bolts (25) from the bottom of each king pin (26) (**Figure 7-19, Page 7-19**).
4. Remove the four bolts (30), four nuts (32), four lock washers (31), and bottom spring plate (29).
5. Remove leaf spring (6).
6. Check the condition of the urethane bushings (27) and steel sleeves (28). Replace any that are worn or damaged.

### LEAF SPRING INSTALLATION

1. Install urethane bushings (27) and steel sleeves (28) into leaf spring eyes (**Figure 7-19, Page 7-19**).
2. Install tapered leaf spring (6), bottom spring plate (29), four bolts (30), four lock washers (31), and four nuts (32). Using a crisscross pattern sequence, tighten bolts to 23 ft·lb (31 N·m).
3. Install spring in king pins (26) with bolts (25) and nuts (14). Tighten to 17 ft·lb (23 N·m).
4. Install the wheels and lower the vehicle. **See Wheel Installation, Section 8, Page 8-1.**
5. Adjust camber and toe-in. **See Camber Adjustment on page 7-15 and Toe-in Adjustment on page 7-16.**

### KINGPIN AND STEERING SPINDLE REMOVAL – MAINTENANCE-FREE BALL JOINTS

1. Remove the front hub. **See Front Hub and Wheel Bearings Removal on page 7-21.**
2. Remove nuts (20) and remove ball joints from spindles (**Figure 7-18, Page 7-18**). Remove drag link ball joint. **See also Tie Rod and Drag Link Removal – Maintenance-Free Ball Joints on page 7-14.**
3. Remove the lock nut (17) and conical washer (34) from the top of the kingpin (26) (**Figure 7-19, Page 7-19**).
4. Raise the upper clevis (16) from the kingpin.
5. Remove the flat washer (33) and thrust washer (19).
6. Slide the spindle (1 or 2) off the kingpin (26).
7. Remove the wave washer (35) and inspect it. If the washer is broken or has a wave bottom to wave crest height dimension of less than 0.040 inch (0.10 cm), it must be replaced.
8. Remove bolt (25) and nut (14) from bottom of kingpin (26) and remove kingpin.
9. Inspect the kingpin and spindle. If either is worn or damaged, it must be replaced.
10. Inspect the bushings (3 and 4). If the bushings are worn or damaged, remove them and press in new ones. **See following NOTE.**

**NOTE:** If the bushings are replaced, ream new bushings from 0.750 inch to 0.752 inch (19.05 to 19.10 mm) in diameter. The reamer should be long enough to ream both bushings from one direction.

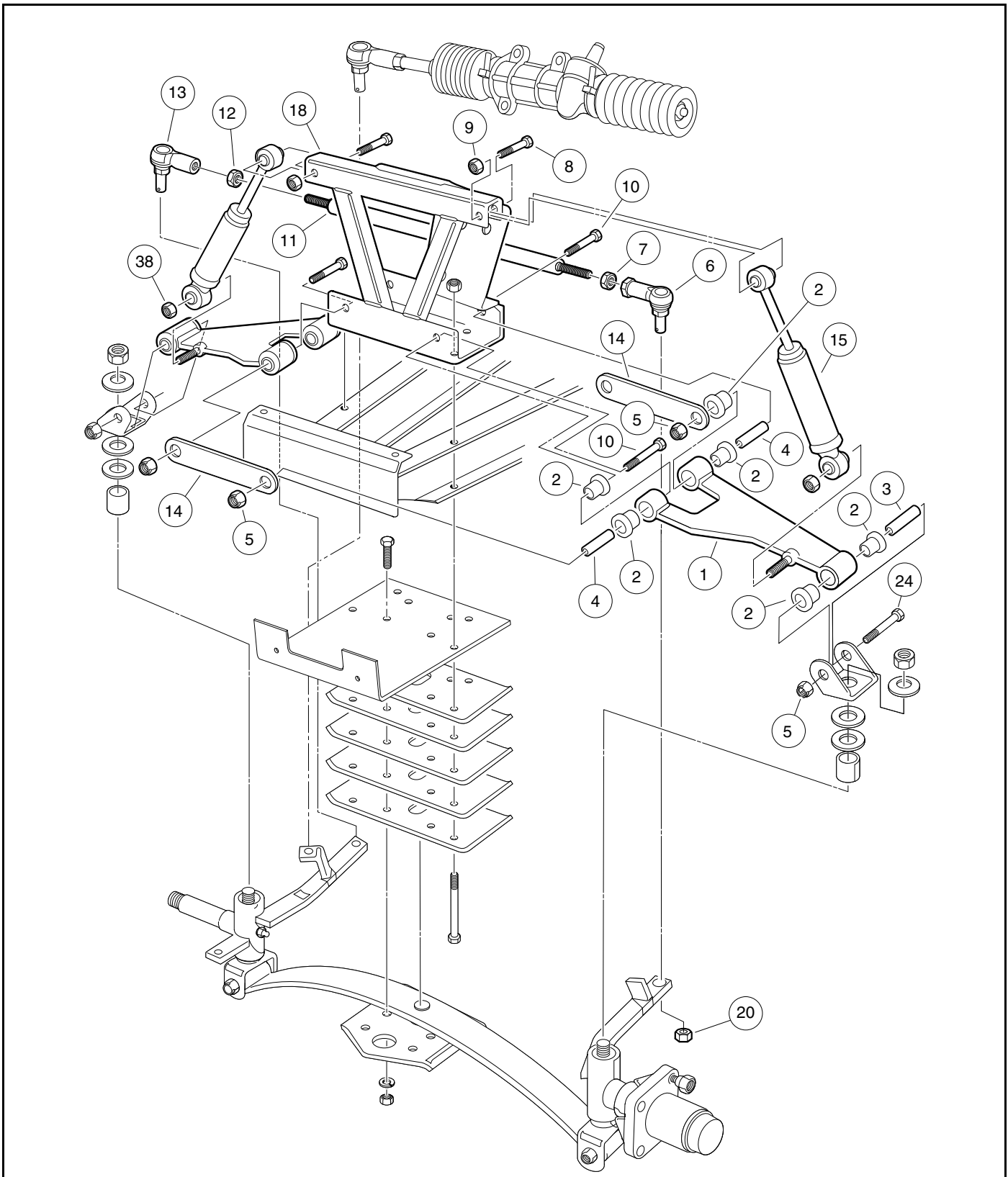

2610

Figure 7-18 Front Suspension – Upper Portion

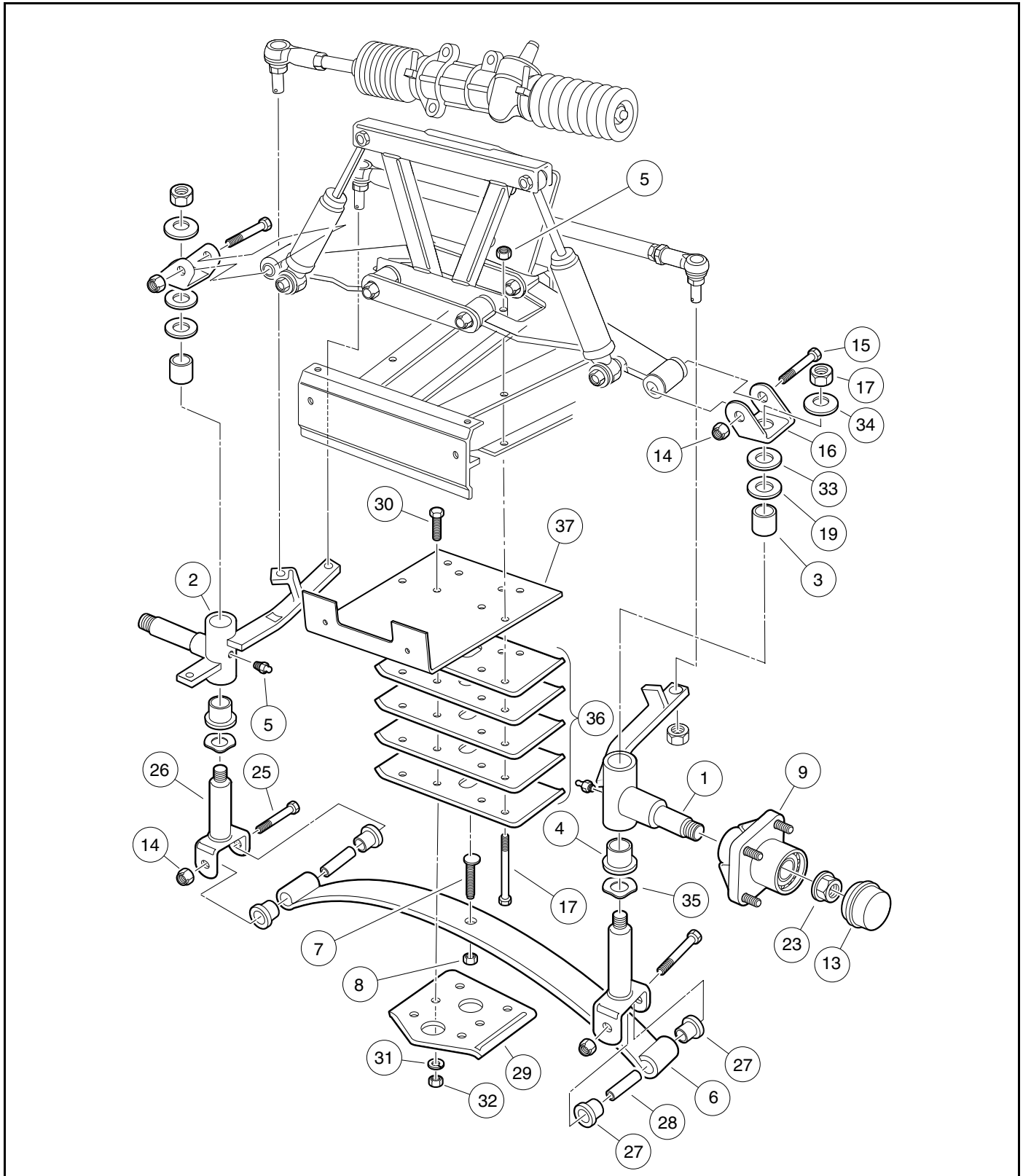

2611

Figure 7-19 Front Suspension – Lower Portion

## KINGPIN AND STEERING SPINDLE INSTALLATION – MAINTENANCE-FREE BALL JOINTS

1. Inspect all parts and replace them as necessary.
2. Install the kingpin (26) over the leaf spring eye. Insert the bolt (25) and install the nut (14) (**Figure 7-19, Page 7-19**). Tighten the bolt to 17 ft·lb (23 N·m).
3. Install the wave washer (35).
4. Install the steering spindle on the kingpin. Then install the thrust washer (19), flat washer (33), upper plate clevis (16), conical washer (34), and nut (17). Tighten the nut to 65 ft·lb (88 N·m).
5. Attach the tie rod ball joints (6 and 13) to the spindle tabs, then install and tighten the nuts (20) to 40 ft·lb (54 N·m) (**Figure 7-18, Page 7-18**).
6. Install the drag link ball joint. **See Tie Rod and Drag Link Installation – Maintenance-Free Ball Joints on page 7-14.**
7. Install front hub and wheel. **See Front Hub and Wheel Bearings Installation on page 7-22.**

## DELTA A-PLATE REMOVAL

1. Remove front wheel(s). **See Wheel Removal, Section 8, Page 8-1.**
2. Remove bolts (10 and 24), A-Plate straps (14), and nuts (5) (**Figure 7-18, Page 7-18**).
3. Remove the lower shock absorber mounting nut (38), then slide the shock absorber (15) free of the Delta A-Plate (1).
4. Remove the Delta A-Plate (1).
5. Inspect the bushings (2) and sleeves (3 and 4) in the Delta A-Plate and replace them if necessary.

## DELTA A-PLATE INSTALLATION

1. Install the A-Plate (1) in reverse order of removal. Tighten the A-Plate suspension bolts (10 and 24) to 20 ft·lb (27 N·m) (**Figure 7-18, Page 7-18**).
2. Tighten shock absorber mounting nut (38) to 20 ft·lb (27.1 N·m).
3. Install the wheel(s). **See Wheel Installation, Section 8, Page 8-1.**
4. Adjust the wheel alignment. **See Wheel Alignment on page 7-15.**

## SHOCK ABSORBER REMOVAL

1. Inspect the shock absorbers (15) for fluid leakage at the point where the shaft enters the shock absorber body. Leaking shock absorbers should be replaced.
2. Remove the nut (38) attaching the shock absorber to the A-Plate (1) (**Figure 7-18, Page 7-18**).
3. Remove the nut (9) and bolt (8) attaching the shock absorber to the shock and gear support (18).
4. Remove the shock absorber (15).

## SHOCK ABSORBER INSTALLATION

**NOTE:** When installing shock absorbers, make sure front shocks have identical part numbers and rear shocks have identical part numbers.

1. Install the shock absorber by reversing the removal procedure.
2. Tighten the nuts (9 and 38) to 20 ft·lb (27 N·m).

## FRONT WHEEL BEARINGS AND HUBS

See General Warnings on page 1-1.

### FRONT WHEEL FREE PLAY INSPECTION

1. Raise the front of the vehicle.
2. Using your hands, attempt to rock the wheel and hub assembly back and forth on the spindle. If there is any observable movement of the wheel and hub on the spindle, remove dust cap (1) and cotter pin (2) and then tighten the spindle nut (3) until the bearing (5) fully seats in the bearing race (7) (**Figure 7-20, Page 7-21**).
3. Loosen spindle nut one cotter pin position. If the hub does not turn freely, loosen spindle nut one more cotter pin position.
4. Install a new cotter pin (2). If movement continues, replace the wheel bearings (5) as required (**Figure 7-20, Page 7-21**).

### FRONT HUB AND WHEEL BEARINGS REMOVAL

1. Remove the front wheels. **See Wheel Removal on page 8-1.**
2. Remove the front wheel hubs.
  - 2.1. Remove dust cover (1), cotter pin (2), spindle nut (3), and flat washer (8) (**Figure 7-20, Page 7-21**).
  - 2.2. Remove the hub assembly (4) from the spindle shaft (**Figure 7-20, Page 7-21**).
3. Remove the seal (6) and the bearings (5) from the hub (**Figure 7-20, Page 7-21**).
4. Inspect the bearing cups (7). If they are worn or pitted, remove the cups by inserting a drift punch from the opposite end of the hub and tapping lightly around them (**Figure 7-20, Page 7-21**).
5. Clean all parts and inspect them for wear. Replace any damaged or worn parts. **See following NOTE.**

**NOTE:** Do not use compressed air to dry wheel bearings after cleaning.

6. Inspect the surface of the spindle shaft where the seal (6) seats. It should be clean and smooth (**Figure 7-20, Page 7-21**).

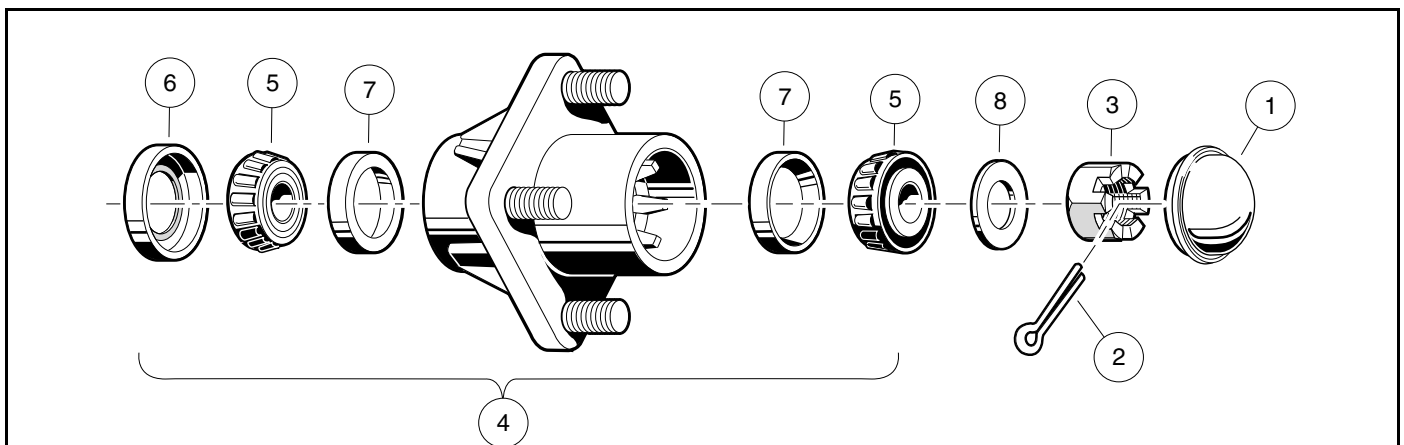

1500-18700-10273

**Figure 7-20 Front Wheel Bearings and Hub**

## FRONT HUB AND WHEEL BEARINGS INSTALLATION

1. Pack the wheel bearings (5) and hub cavities, and lubricate cups (7) with wheel bearing grease or chassis lube. Make sure the grease is forced between the rollers (**Figure 7-20, Page 7-21**).
2. If bearing cups (7) were removed, press new ones in squarely against stops in the hub (**Figure 7-20, Page 7-21**).

**NOTE:** Install new cups when new bearings are installed.

3. Install the wheel bearings (5) into the hub and install a new seal (6), with the metal edge toward the hub (**Figure 7-20, Page 7-21**). See following **NOTE**.

**NOTE:** Apply grease around dust seal inner lip before installation.

4. Install the hub assembly (4) and flat washer (8) on the spindle and start the spindle nut (3) (**Figure 7-20, Page 7-21**).
5. Tighten the spindle nut (3) until the hub is hard to turn, then back the nut off until the hub turns freely. Install a new cotter pin (2) (**Figure 7-20, Page 7-21**). See following **WARNING** and **NOTE**.

### **⚠ WARNING**

- **Make sure to install and bend the cotter pin. Failure to bend the cotter pin could result in the separation of the wheel hub from the spindle. Loss of vehicle control could result, causing death or severe personal injury.**

**NOTE:** When the cotter pins are bent, make sure they do not contact the hub or dust cap.

6. Check front wheel free play. See **Front Wheel Free Play Inspection** on page 7-21.
7. Install the dust cap (1) (**Figure 7-20, Page 7-21**).
8. Repeat the procedure for the opposite wheel.
9. Install the wheels and then finger tighten the lug nuts.
10. Lower the vehicle and finish tightening lug nuts, using a crisscross pattern, to 55 ft·lb (74.6 N·m).



### **⚠ DANGER**

- See General Warnings on page 1-1.

### **⚠ WARNING**

- See General Warnings on page 1-1.

## GENERAL INFORMATION

---

*NOTE: Use only Club Car approved tires when replacing tires.*

Maximum tire life and good vehicle handling qualities are directly related to proper wheel and tire care.

- Keep tires properly inflated. **See Vehicle Specifications on page 2-1.**
- Keep lug nuts properly tightened.
- Keep the front end properly aligned and adjusted.

## WHEELS

---

See General Warnings on page 1-1.

### WHEEL REMOVAL

1. Slightly loosen the lug nuts on the wheel to be removed.
2. Raise the end of the vehicle from which the wheel is to be removed. Make sure the wheels are off the ground. **See WARNING “Lift only one end of the vehicle...” in General Warnings on page 1-1.**
3. Remove the lug nuts and remove the wheel.

### WHEEL INSTALLATION

1. Install wheel(s), and tighten the lug nuts, using a crisscross pattern, until they are snug.
2. Lower the vehicle and finish tightening the lug nuts, using a crisscross pattern, to 65 ft·lb (88 N·m).

## TIRES

See General Warnings on page 1-1.

### TIRE REMOVAL

**NOTE:** Tire must be removed or installed from the valve stem side of the rim.

1. Remove the tire and wheel assembly from the vehicle as instructed above. **See Wheel Removal on page 8-1.**
2. Remove the valve cap and valve core and allow air to escape from the tire.
3. If possible, use a tire machine to remove the tire from the rim.
  - 3.1. If a tire machine is not available, loosen both tire beads by applying pressure to the tire side walls and pushing the tire bead away from the rim flange and into the rim well (**Figure 8-1, Page 8-2, Detail A**).
  - 3.2. With the valve stem side of the wheel up, use a tire tool to carefully start the upper bead over the edge of the rim (**Figure 8-1, Page 8-2, Detail B**). **See following CAUTION.**

### CAUTION

- To avoid damage to the tire, do not use excessive force when starting the bead over the edge of the rim.
- 3.3. When top bead is free of the rim, pull the bead from the bottom side of the rim up into the upper part of the rim well. Insert the tire tool under the lower bead as shown (**Figure 8-1, Page 8-2, Detail C**) and carefully pry the lower bead over the rim flange.
  - 3.4. Once the lower bead is started over the rim flange, the tire can be removed from the rim by hand.

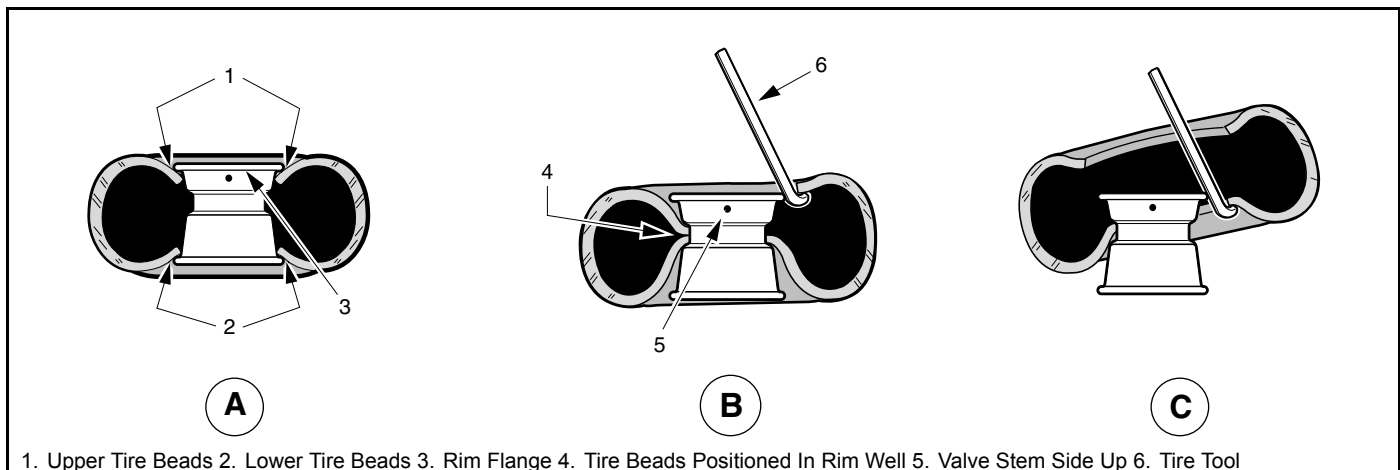

Figure 8-1 Tire Removal

### TIRE REPAIR

1. Determine the location and cause of the air leak.
  - 1.1. Remove the wheel. **See Wheel Removal on page 8-1.** Inflate the tire to no more than 20 psig (138 kPa).
  - 1.2. Immerse the tire in water and then mark the point where bubbles are formed by escaping air.
  - 1.3. Determine the cause of the air leak. **See following NOTE.**

**NOTE:** An air leak could be due to a punctured casing, faulty valve core, improperly seated valve stem, or improperly seated tire bead.

*Small holes in the casing can be plugged using a standard automotive tubeless tire repair kit available at auto supply stores.*

2. When the cause of the air leak has been determined, remove tire from the rim and repair as required. **See Tire Removal on page 8-2.**

## TIRE INSTALLATION

### **⚠ WARNING**

- **While mounting or inflating tire, keep hands, fingers, etc. from exposed areas between the tire bead and rim.**

1. Clean both tire beads to remove dirt or other foreign matter.
2. Where the tire beads seat, clean the rim with a wire brush. Wipe away any debris with a clean cloth. **See following NOTE.**

**NOTE:** Because tubeless tires require a perfect seal in order to seat, keeping the tire and rim clean is very important.

3. Apply a liberal amount of tire-mounting lubricant (soap and water solution) to both tire beads and rim flanges.
4. Install the tire on the rim from the valve stem side. If there is no tire machine available, use a rubber mallet and tire iron.
5. Remove the valve core, and position the tire so that both beads are on the rim flange narrow bead seats.
6. Place the tire and wheel assembly against a wall in an upright position and push it against the wall while inflating the tire to the recommended pressure. **See Vehicle Specifications on page 2-1.** The three-point contact (wall, floor, and hand) will help ensure that beads snap into place and form a proper seal as the tire is inflated (**Figure 8-2, Page 8-4**). **See following WARNING.**

### **⚠ WARNING**

- **Do not use a compressed air source with pressure over 100 psig (689.5 kPa). Due to the low pressure requirements of a small tire, over-inflation could be reached almost instantly when using a high pressure air supply. Over-inflation could cause the tire to explode, possibly resulting in personal injury.**
7. Quickly remove the air nozzle and install the valve core.
  8. Adjust air pressure in the tire to recommended pressure. **See Vehicle Specifications on page 2-1.**
  9. Immerse the wheel and tire assembly in water to make sure there are no leaks.



Figure 8-2 Inflate Tire

## **⚠ DANGER**

- See General Warnings on page 1-1.

## **⚠ WARNING**

- See General Warnings on page 1-1.

## GENERAL INFORMATION

The rear suspension and powertrain of the vehicle move independently from the vehicle frame. It consists of two leaf springs controlled by two shock absorbers mounted between the springs and the vehicle frame.

## SHOCK ABSORBERS

See General Warnings on page 1-1.

### SHOCK ABSORBER INSPECTION AND REMOVAL

1. Check shock absorbers (19) for damage or fluid leakage at the point where the shaft enters the shock absorber body. Replace damaged or leaking shock absorbers (**Figure 9-1, Page 9-1**) and (**Figure 9-4, Page 9-4**).
2. To remove a shock absorber, remove the nut (1), cup washers (4), and rubber bushings (3) from the stem at the top of the shock absorber.
3. Remove lower mounting hardware (1, 3, and 4) on shock absorber lower mount.
4. Compress the shock absorber to remove it.

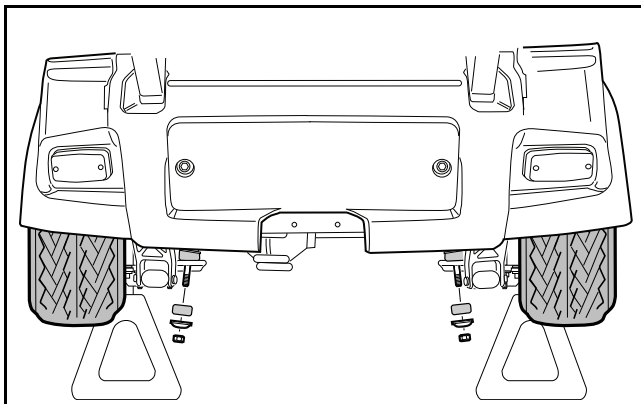

2860  
**Figure 9-1 Shock Absorber Removal**

### SHOCK ABSORBER INSTALLATION

**NOTE:** When installing shock absorbers, make sure front shocks have identical part numbers and rear shocks have identical part numbers.

**NOTE:** Tighten 3/8 hex nut at shock absorber until shock absorber cushions are approximately the same diameter as the retainers. Do not over tighten.

1. On the upper and lower shock absorber mounting stems, tighten the nut (1) until the rubber bushing (3) expands to the size of the cup washer (4).

## MULTI-LEAF SPRINGS

---

See General Warnings on page 1-1.

### MULTI-LEAF SPRING REMOVAL

1. Disconnect the battery cables and either discharge the controller or disconnect the spark plug wire(s). **See Disconnecting the Battery-Gasoline Vehicles on page 1-3.**
2. Loosen, but do not remove, lug nuts on tire and wheel assembly on the side from which the spring is to be removed. Place chocks at the front wheels and lift the rear of the vehicle with a chain hoist or floor jack. Position jack stands under the frame crossmember between the spring mount and the side stringer, just forward of each rear wheel. Lower the vehicle to let the jack stands support the vehicle (**Figure 9-2, Page 9-3**). **See following WARNING.**

### **⚠ WARNING**

- **Lift only one end of the vehicle at a time. Use a suitable lifting device (chain hoist or hydraulic floor jack) with 1000 lb (454 kg) minimum lifting capacity. Do not use lifting device to hold vehicle in raised position. Use approved jack stands of proper weight capacity to support the vehicle and chock the wheels that remain on the floor. When not performing a test or service procedure that requires movement of the wheels, lock the brakes.**
3. Place a floor jack under the transaxle differential casing to support (but not lift) the drivetrain. Raise it just enough to relieve tension on the shock absorbers without compressing them.
  4. Remove the tire and wheel assembly on the side from which the spring is to be removed.
  5. Remove the bow-tie pin (1) and the clevis pin (2) at the brake lever and brake cable connection and pull the clevis (3) away from the lever (**Figure 9-3, Page 9-3**). Detach the brake cable from the shock mount bracket (**Figure 9-2, Page 9-3**).
  6. Remove the nut (1), cup washers (4), and rubber bushings (3) from the lower mounting stem of the shock absorber (**Figure 9-4, Page 9-4**).
  7. Remove the nuts (7) and the U-bolt (9) securing the spring to the shock mounting bracket (16). Remove the shock mount bracket (6), angle bracket (8), and the U-bolt (**Figure 9-4, Page 9-4**).
  8. Remove the nut (11) and bolt (17) attaching the rear spring to the lower end of the shackle brackets (13).
  9. Remove the nut (11) and bolt (17) attaching the front of the spring to the vehicle frame and remove the spring.
  10. Inspect the bushings and spacers in the spring eyes and replace them if they are worn or damaged.

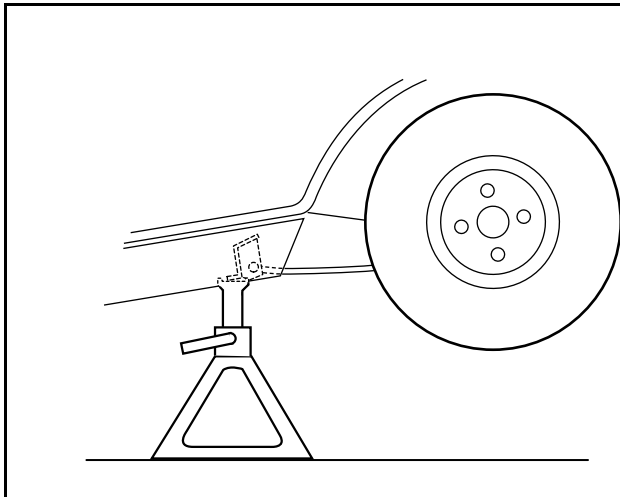

2600-30000-10369

Figure 9-2 Support Vehicle on Jack Stands

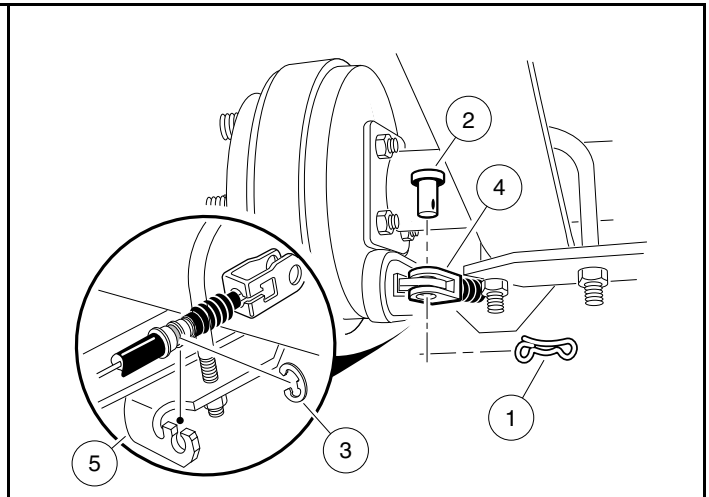

1400-18100-10243

Figure 9-3 Disconnect Brake Cable

## MULTI-LEAF SPRING INSTALLATION

**NOTE:** Tighten bolt (11) after clamp from brake cable has been positioned between nut and frame component.

1. Install the bushings and spacers in the spring eyes. **See following CAUTION.**

### **CAUTION**

- **When positioning the spring on the transaxle, be sure to insert the locating bolt on the spring in the locating hole in the transaxle saddle.**
2. Install the nut (11) and bolt (17) attaching the front of the spring to the vehicle frame and install the spring.
  3. Install the nut (11) and bolt (17) attaching the rear spring to the lower end of the shackle brackets (13).
  4. Install the nuts (7) and the U-bolt (9) securing the spring to the shock mounting bracket (16). Install the shock mount bracket (6), angle bracket (13) and the U-bolt.
  5. Tighten the nuts (7) on the U-bolt (9) to 22 to 27 ft·lb (30 to 37 N·m).
  6. Install the nut (1), cup washers (4), and rubber bushings (3) to the lower mounting stem of the shock absorber
  7. Tighten nylon lock nuts (11) on spring mounting bolts (17) to 17 to 20 ft·lb (24 to 28 N·m) (**Figure 9-4, Page 9-4**).
  8. Tighten the nuts (1) until the rubber bushing (3) expands to the size of the cup washer (4).
  9. Connect the battery cables. **See Connecting the Battery-Gasoline Vehicles on page 1-3.**

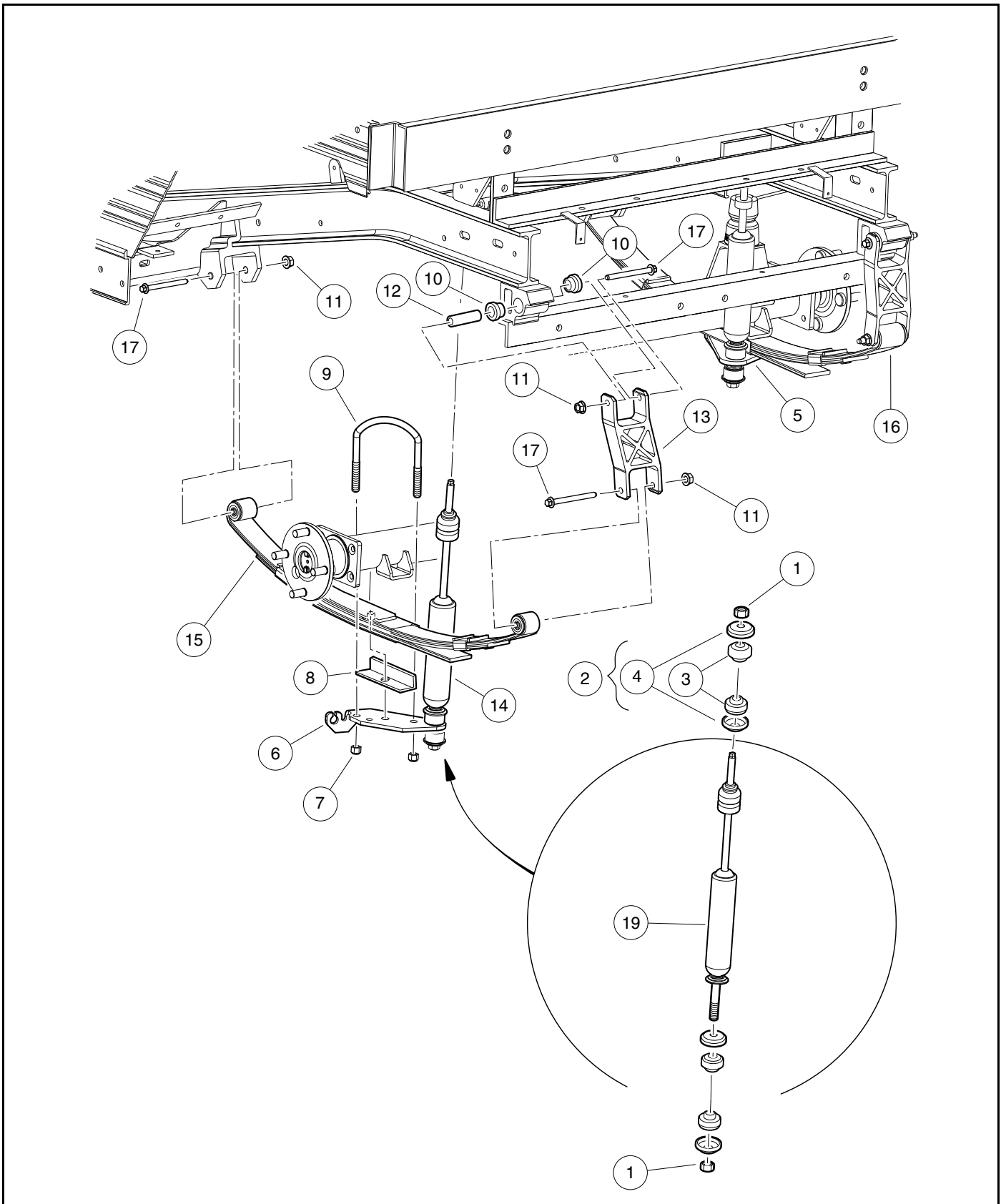

2987

Figure 9-4 Rear Suspension Assembly and Mounting



## GENERAL INFORMATION

---

See **General Warnings** on page 1-1.

To ensure trouble-free vehicle performance, it is very important to follow an established preventive maintenance program (regularly scheduled service). Regular and consistent vehicle maintenance can prevent vehicle down-time and expensive repairs that result from neglect. Any vehicle not functioning correctly should be removed from use until it is properly repaired. This will prevent further damage to the vehicle and avoid the possibility of injury due to unsafe conditions.

Contact your local authorized distributor/dealer to perform all repairs and semiannual and annual periodic service.

## PRE-OPERATION AND DAILY SAFETY CHECKLIST

---

Each Club Car vehicle has been thoroughly inspected and adjusted at the factory; however, upon receiving your new vehicle(s), you should become familiar with its controls, indicators, and operation. Carefully inspect each vehicle to ensure that it is in proper working condition before accepting delivery.

Use the following checklist as a guide to inspect the vehicle. This checklist should be used daily to ensure that the vehicle is in proper working condition and in conjunction with the Performance Inspection on page 10-2 and the Periodic Service Schedule on page 10-3. Any problems should be corrected by a Club Car distributor/dealer or a trained technician.

Do not operate the vehicle until the upper cabinet, canopy, and windshield have been installed.

- **Safety Video:** Have all operators view the safety video that was provided with the vehicle and understand the safety warnings it illustrates before operating the vehicle.
- **General:** All the parts should be in place and properly installed. Be sure that all nuts, bolts, and screws are tight. On gasoline vehicles, check all hose clamps for tight fit as well as the starter belt for tightness.
- **Windshield:** Ensure that the windshield is installed before driving the vehicle.
- **Safety and information decals:** Check to ensure that all safety and information decals are in place.
- **Tires:** Check for proper tire pressure upon delivery and on a daily basis when the vehicle is in service. **See Vehicle Specifications on page 2-1.**
- **Loading:** Before driving the vehicle, ensure that the load weight is evenly distributed in the Cafe Express refreshment center.
- **Battery (gasoline vehicles):** Check battery posts. Wires should be tight and free of corrosion and battery should be fully charged.
- **Engine:** Check for proper engine oil level. Inspect air intake for blockage.
- **Fuel:** Check fuel level. Check fuel tank, fuel injector, lines, cap, and pump for fuel leakage on a daily basis.
- **Performance Inspection:** Inspect as instructed. **See Performance Inspection on page 10-2.**

## **⚠ WARNING**

- **Be sure the plastic has been removed from the seat bottom before operating the vehicle. Failure to do so can result in a fire, property damage, personal injury, or death.**

## **PERFORMANCE INSPECTION**

After you have familiarized yourself with the vehicle controls and have read and understood the driving instructions, take the vehicle for a test drive.

Use the following checklist, in conjunction with the Pre-Operation and Daily Safety Checklist, as a guide to inspect the vehicle and check daily for proper operation. Any problems should be corrected by a Club Car distributor/dealer or a trained technician.

- **Governor:** Check maximum speed of the vehicle. The vehicle should operate at 14 mph (23 km/h) or less on a level surface. With the neutral lockout switch in the MAINTENANCE position, check the maximum engine RPM with a tachometer. The correct setting for safe operation is 2350 RPM ( $\pm 30$ ).
- **Forward/Reverse control:** Check for proper operation.
- **Brakes:** Be sure the brakes function properly. When brake pedal is fully pressed under moderate pressure, it should not go more than halfway to the floor, and vehicle should come to a smooth, straight stop. If the brake pedal goes more than halfway to the floor, or if the vehicle swerves or fails to stop, have the brake system checked and adjusted as required. Brake adjustment must be maintained so that the brake pedal cannot be pressed to the floor under any circumstance.
- **Park brake:** When latched, the park brake should lock the wheels and hold the vehicle stationary (on an incline of 20% or less). It should release when either the accelerator or brake pedal is pressed.
- **Reverse buzzer:** The reverse buzzer should sound as a warning when the Forward/Reverse handle or switch is in the REVERSE position.
- **Steering:** The vehicle should be easy to steer and should not have any play in the steering wheel.
- **General:** Listen for any unusual noises such as squeaks or rattles. Check the vehicle ride and performance. Have a Club Car distributor/dealer or a trained technician investigate anything unusual.
- **Accelerator pedal:** With the key switch in the ON position and the Forward/Reverse handle in the FORWARD position, as the accelerator pedal is pressed, the engine should start and the vehicle should accelerate smoothly to full speed. When the pedal is released, it should return to the original position and the engine should stop.

## **MAINTENANCE**

See General Warnings on page 1-1.

To ensure trouble-free vehicle performance, it is very important to follow an established preventive maintenance program. Regular and consistent vehicle maintenance can prevent vehicle downtime and expensive repairs that can result from neglect. Use the Pre-Operation and Daily Safety Checklist on page 10-1 and the following *Periodic Service Schedule* and *Periodic Lubrication Schedule* to keep the vehicle in proper working condition.

Any vehicle not functioning correctly should be removed from use until it is properly repaired. This will prevent further damage to the vehicle and avoid the possibility of injury due to unsafe conditions.

Contact your local Club Car distributor/dealer to perform all repairs and semiannual and annual periodic service.

## **WARNING**

- If any problems are found during scheduled inspection or service, do not operate the vehicle until repairs are made. Failure to make necessary repairs can result in fire, property damage, serious personal injury, or death.
- Only trained technicians should service or repair the vehicle. Anyone doing even simple repairs or service should have knowledge and experience in electrical and mechanical repair. The appropriate instructions must be used when performing maintenance, service, or accessory installation.
- Do not work on vehicle powertrain or under the cargo bed when it is loaded.
- Do not wear loose clothing or jewelry, such as rings, watches, chains, etc., when servicing the vehicle.
- Turn the key switch to OFF, remove the key, place the Forward/Reverse handle or switch in the NEUTRAL position, and chock tires prior to servicing.
- Do not close bed until all persons are clear of the bed area. Failure to follow these instructions can result in serious personal injury.
- Moving parts: Do not attempt to service gasoline vehicle while the engine is running.
- Hot! Do not attempt to service hot engine or exhaust system. Failure to heed this warning can result in serious burns.
- To avoid unintentionally starting the vehicle, disconnect battery and spark plug wire. See Disconnecting the Battery-Gasoline Vehicles on page 1-3.
- Frame ground – Do not allow tools or other metal objects to contact frame when disconnecting batteries or other electrical wiring. Never allow a positive wire to touch the vehicle frame, engine, or other metal component.

## PERIODIC SERVICE SCHEDULE

See General Warnings on page 1-1.

## **WARNING**

- Service, repairs, and adjustments must be made per instructions in the maintenance and service manual.
- If any problems are found during scheduled inspection or service, do not operate the vehicle until repairs are made. Failure to make necessary repairs can result in fire, property damage, serious personal injury, or death.

**NOTE:** *If the vehicle is constantly hauling heavy loads or hauling a trailer, these preventive maintenance procedures should be performed more often than recommended in the Periodic Service Schedule.*

*Both the Periodic Service Schedule and the Periodic Lubrication Schedule must be followed to keep vehicle in optimum operating condition.*

PERIODIC SERVICE SCHEDULE		
REGULAR INTERVAL	SERVICE	
Daily service by owner	Pre-Operation and Daily Safety Checklist	See Pre-Operation and Daily Safety Checklist on page 10-1.
	Performance Inspection	See Performance Inspection on page 10-2.
	Tires	Check air pressure and adjust if necessary. See Vehicle Specifications on page 2-1.
Monthly service by owner or trained technician	Engine	Check engine oil level; change if necessary. See Periodic Lubrication Schedule on page 10-6. Dispose of used oil properly.
		Check engine cooling air intake; visually inspect unshrouded area around engine exhaust for grass and debris, and clean if necessary.
	General vehicle	Wash engine compartment and underside of vehicle. Do not wash engine when hot.
	Door locks	Lubricate with a dry lubricant.
Semiannual service by trained technician only (or every 50 hours of operation, whichever comes first)	Battery	Clean terminals and wash dirt from casing.
	Front wheel alignment and camber	Check and adjust if necessary. See Steering and Front Suspension section in the maintenance and service manual.
	Electrical wiring and connections	Check for tightness and damage.
	Brake system	Check brake shoes; replace if necessary or adjust as required.
		Check brake cables for damage; replace as required.
Check brake cable equalizer adjustment; adjust if necessary.		

TABLE CONTINUED ON NEXT PAGE

PERIODIC SERVICE SCHEDULE		
REGULAR INTERVAL	SERVICE	
<b>Annual service by trained technician only (or every 100 hours of operation, whichever comes first)</b>	Engine	Check for leaks around gaskets, fill plugs, etc.
		Inspect, clean and gap spark plug; replace if necessary.
	Engine air intake system	Check air filter element; clean or replace if necessary.
		Check clamps for tightness; check hose for cracks.
	General vehicle	Check for loose hardware and tighten if necessary. Check the vehicle top speed. Adjust as necessary.
Safety decals	Check safety decals. Replace if damaged or illegible.	
<b>Two-year service by trained technician only.</b>	Engine	Check and adjust valve clearance as needed.

## PERIODIC LUBRICATION SCHEDULE

PERIODIC LUBRICATION SCHEDULE			
REGULAR INTERVAL	SERVICE	LUBRICATION POINTS	RECOMMENDED LUBRICANT
Semiannually by owner or trained technician (or every 50 hours of operation, whichever comes first)	Brake pedal shaft bearings	1	Dry Moly Lube
	Brake linkage and pivots	2	Dry Moly Lube
	Accelerator pivot rod supports and shifter cable pivots	3	Dry Moly Lube
	Front suspension	4	Chassis Lube (EP NLGI Grade 2)
	Brake slides	5	Dry Moly Lube
Annually by trained technician only (or every 100 hours of operation, whichever comes first)	Transaxle: Check/fill to plug level	6	67.6 fl-oz (2 L) SAE 80W-90 API Class GL-5
	Inspect front wheel bearings (Repack as necessary)	7	Chassis Lube – EP NLGI Grade 2
First change 100 hours – additional change every 200 hours of operation or annually, whichever comes first	Change engine oil	8	40.5 fl-oz (1.2 L) See Engine Oil Viscosity

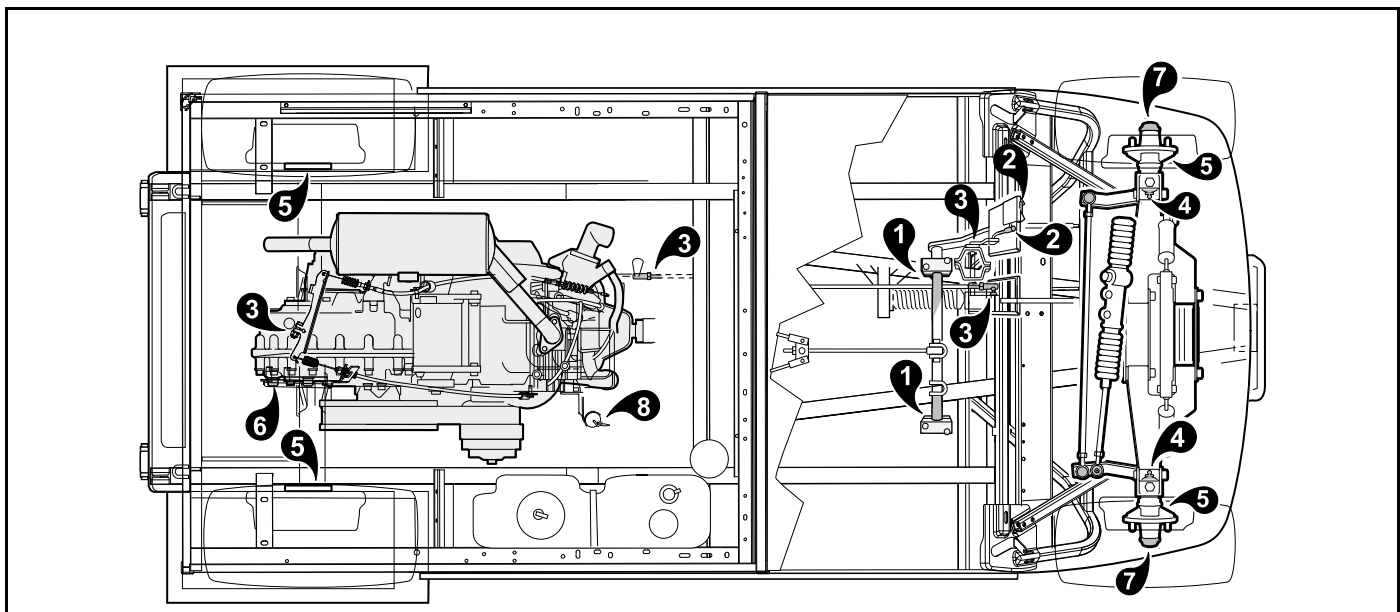

2823

Figure 10-1 Lubrication Points

## AIR FILTER

### **⚠ CAUTION**

- Engine damage will occur if the air cleaner cap is not properly secured.
- If air cleaner is extremely dirty, remove air cleaner from vehicle and clean thoroughly.
- Use only Club Car replacement air filters. The use of other air filters could result in engine damage and void the warranty.

The air filter should be inspected periodically and replaced when necessary. Filter changes should not exceed the recommended interval. More frequent service may be required in extremely dirty operating environments. In the event of a loss of power, sluggish acceleration, or a roughly running engine, service the air filter immediately.

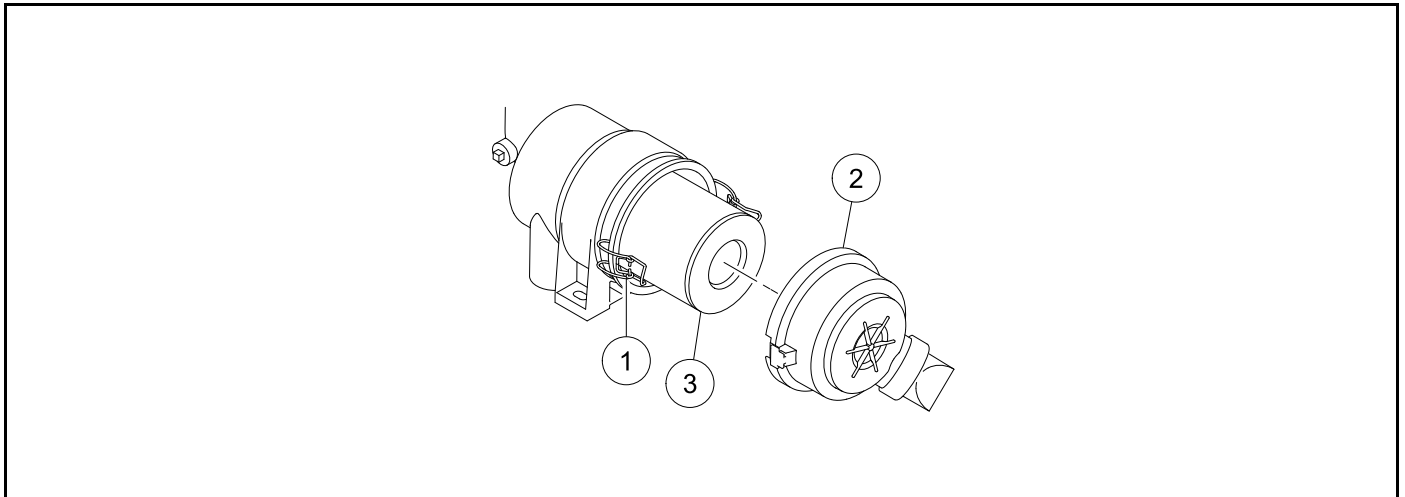

Figure 10-2 Air Filter

### **AIR FILTER REMOVAL**

Before the air filter is removed:

- Disable the vehicle.

To remove the air filter:

1. Release the latches (1).
2. Remove the air cleaner cover (2).
3. Remove the air filter (3).

### **AIR FILTER INSTALLATION**

1. Use a wet lint-free cloth to clean the inside of the air filter container.
2. Install the air filter (3).

**NOTE:** The filter is specifically designed for this engine. It fits into the canister only one way. Use only direct replacement part.

3. Install the air cleaner cover (2).
4. Engage the latches (1).

## ENGINE OIL

### ENGINE OIL VISCOSITY

Select the engine oil viscosity for your environmental conditions.

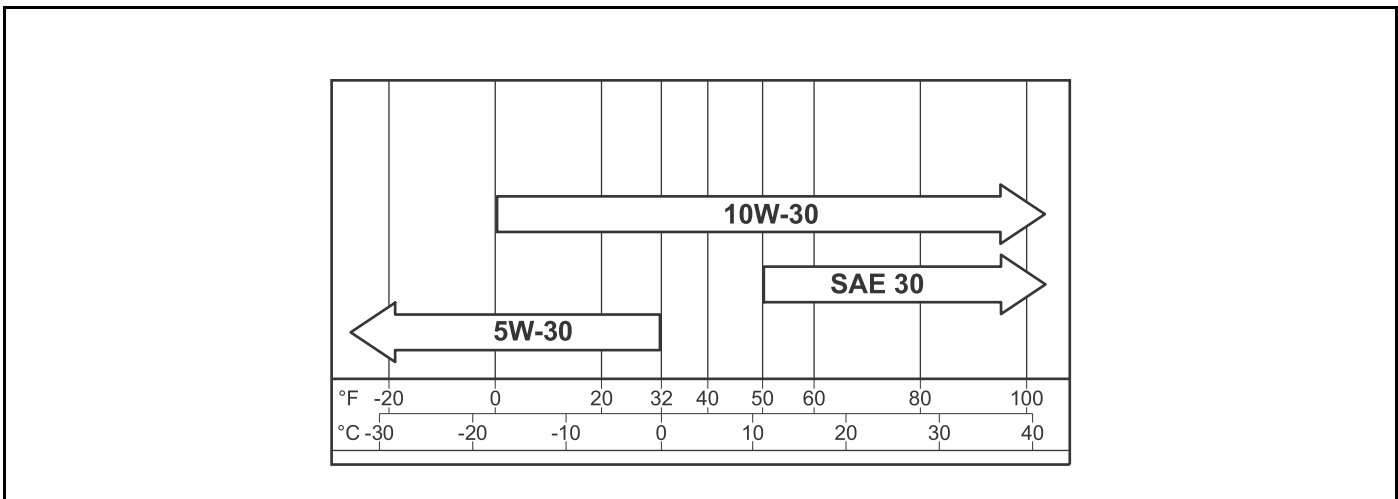

Figure 10-3 Engine Oil Viscosity

### ENGINE OIL LEVEL INSPECTION

Before the engine oil is examined:

- Disable the vehicle.

To examine the engine oil:

1. Remove the dipstick (1) (Figure 10-4, Page 10-9).



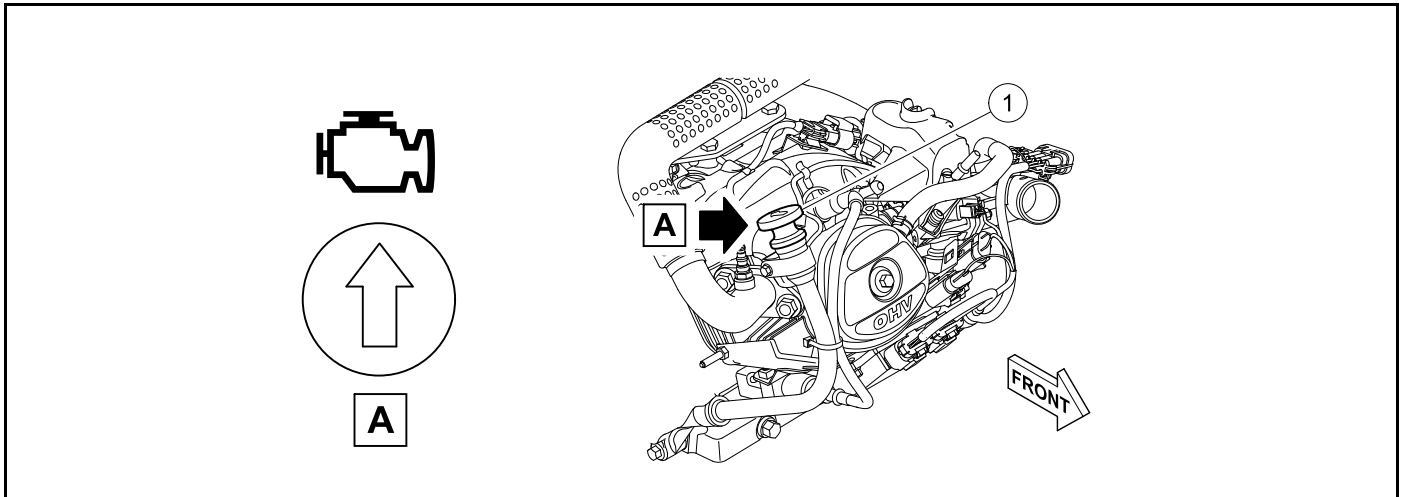

Figure 10-4 Dipstick Location

2. Make sure that the oil level is between the maximum (1) and minimum (2) indicators (Figure 10-5, Page 10-9).

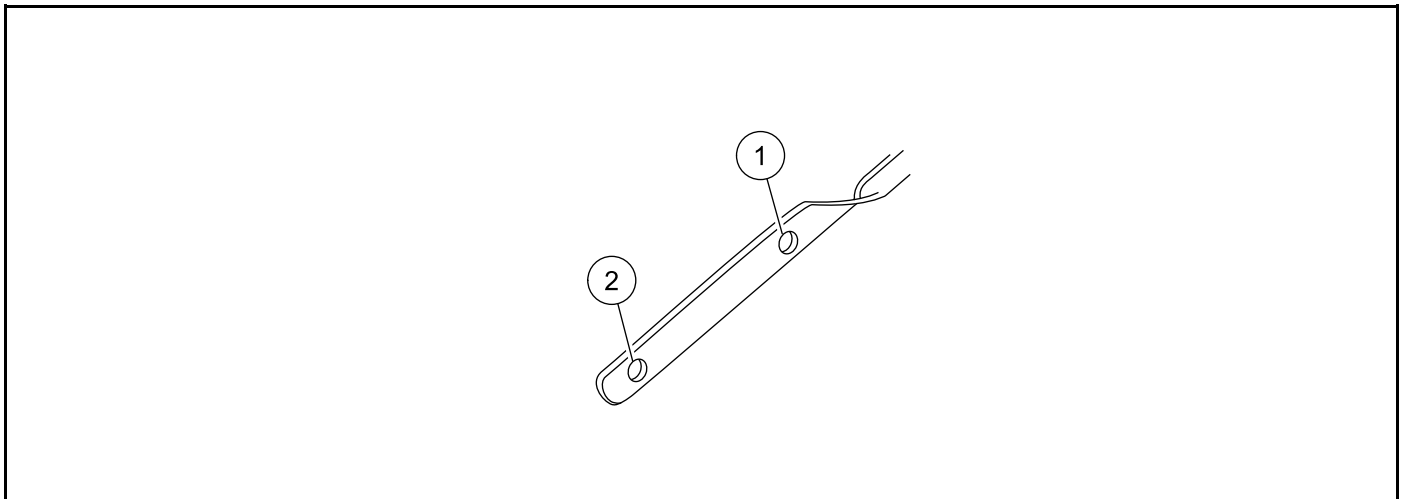

Figure 10-5 Dipstick Indicators

3. If the oil level is below the minimum indicator, add engine oil.
4. Install the dipstick.

**NOTE:** Make sure that the arrow points towards the engine.

## ENGINE OIL REPLACEMENT

### **⚠ CAUTION**

- Hot engine oil will cause skin burns. Do not change the engine oil when the engine is hot. Let the engine temperature decrease before the oil is changed.

### **CAUTION**

- Too much engine oil can decrease engine performance and damage the engine. Do not exceed the recommended engine oil capacity.

Before the engine oil is replaced:

- Disable the vehicle.
- Disconnect the battery.

To replace the engine oil:

1. Remove the dipstick (1) (**Figure 10-6, Page 10-10**).

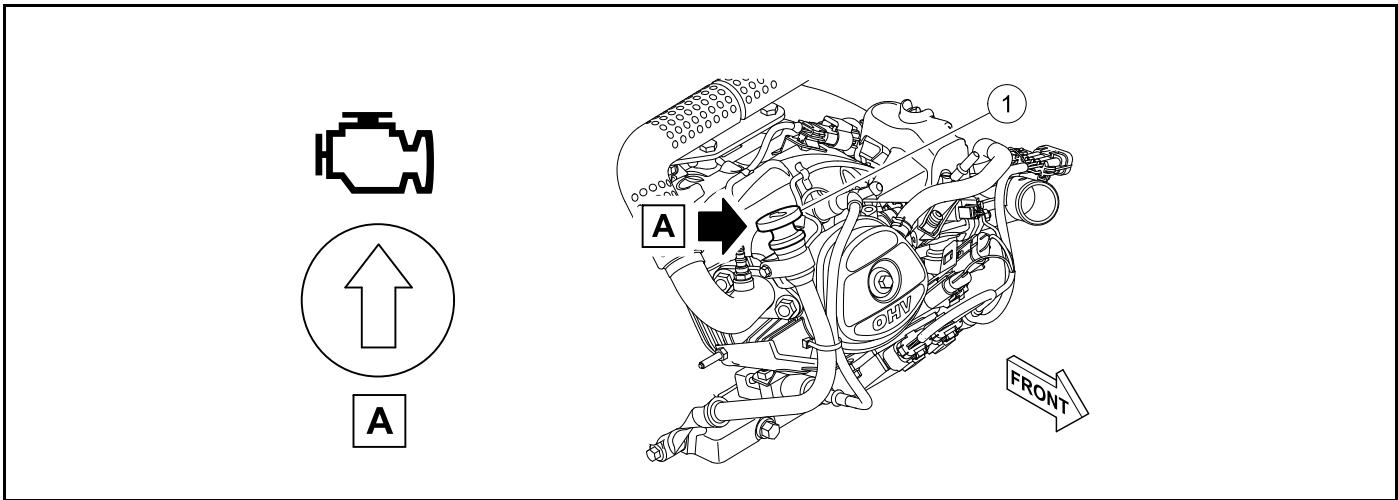

**Figure 10-6 Dipstick Location**

2. Clean the area around the oil drain plug (2) (**Figure 10-7, Page 10-11**).

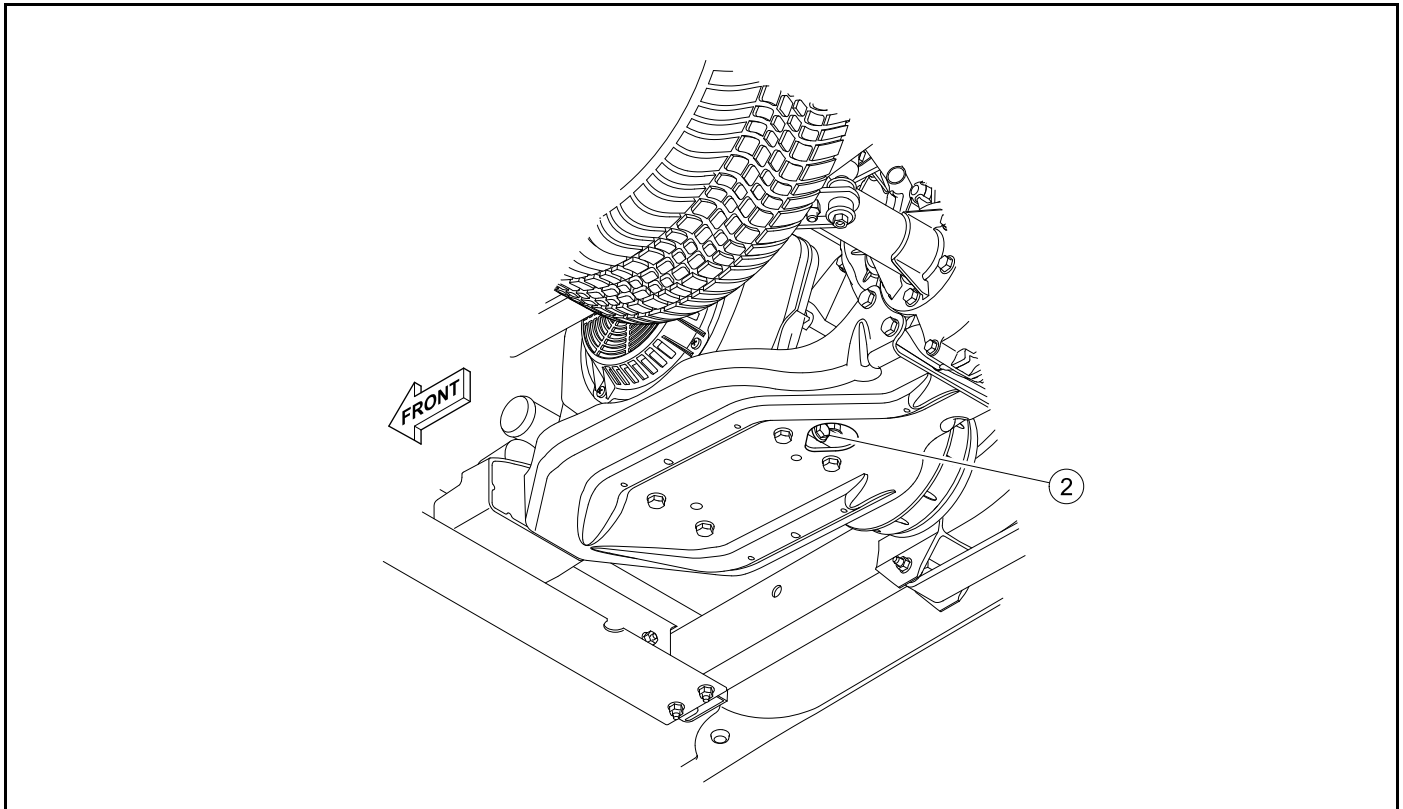

Figure 10-7 Oil Drain Plug

3. Put a drain pan below the oil drain plug.
4. Remove the oil drain plug.
5. Drain the oil fully.
6. Clean the oil drain plug.
7. Examine the gasket on the oil drain plug for damage. Replace if necessary.
8. Install the oil drain plug and tighten to 13 lb·ft (18 N·m).
9. Add 40.5 fl-oz (1.2 l) of recommended engine oil (**Figure 10-8, Page 10-12**).

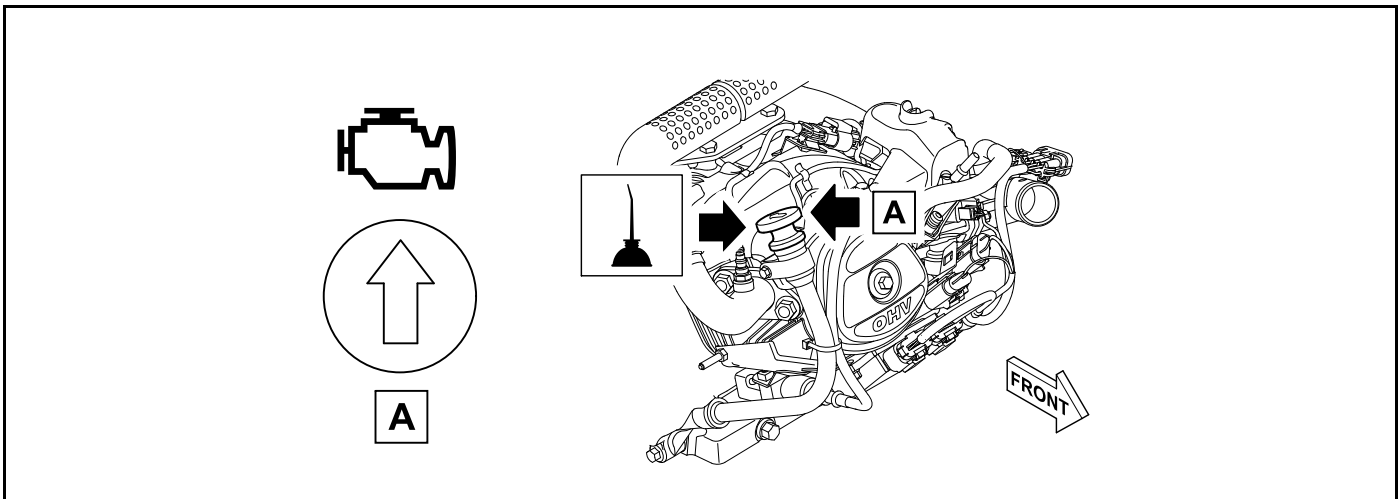

Figure 10-8 Oil Fill Location

10. Install the dipstick.
11. Connect the battery.
12. Correctly discard the used engine oil.

## ADD ENGINE OIL

### **CAUTION**

- Hot engine oil will cause skin burns. Do not change the engine oil when the engine is hot. Let the engine temperature decrease before the oil is changed.

### **CAUTION**

- Too much engine oil can decrease engine performance and damage the engine. Do not exceed the recommended engine oil capacity.

Before the engine oil is added:

- Disable the vehicle.

To add engine oil:

1. Remove the dipstick (1) (Figure 10-9, Page 10-13).

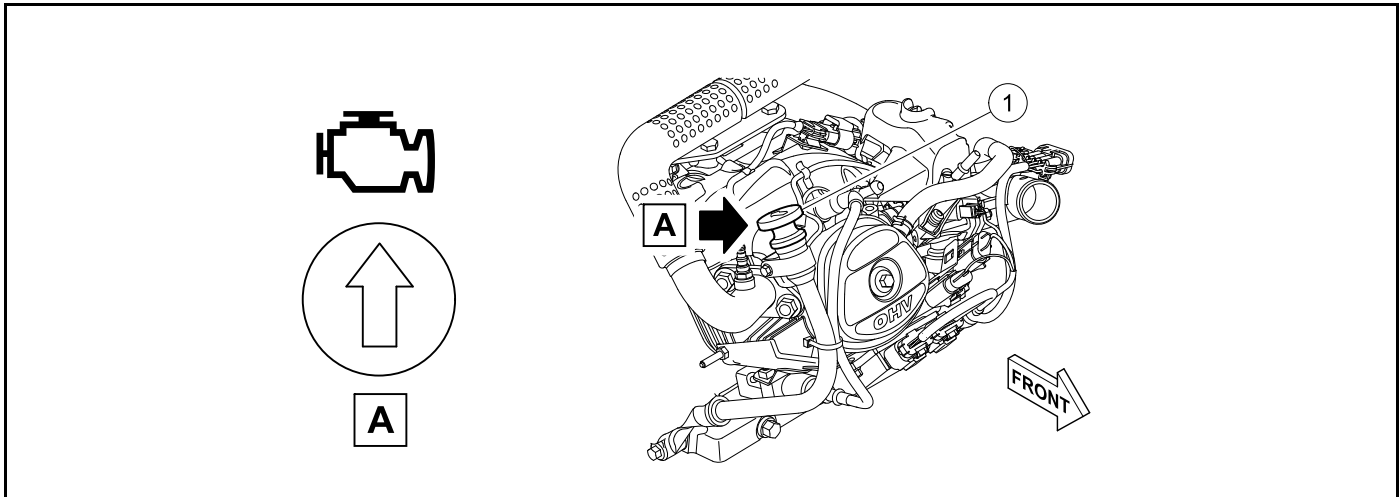

Figure 10-9 Dipstick Location

2. Add engine oil until the oil level is between the maximum (1) and minimum (2) indicators (Figure 10-10, Page 10-13).

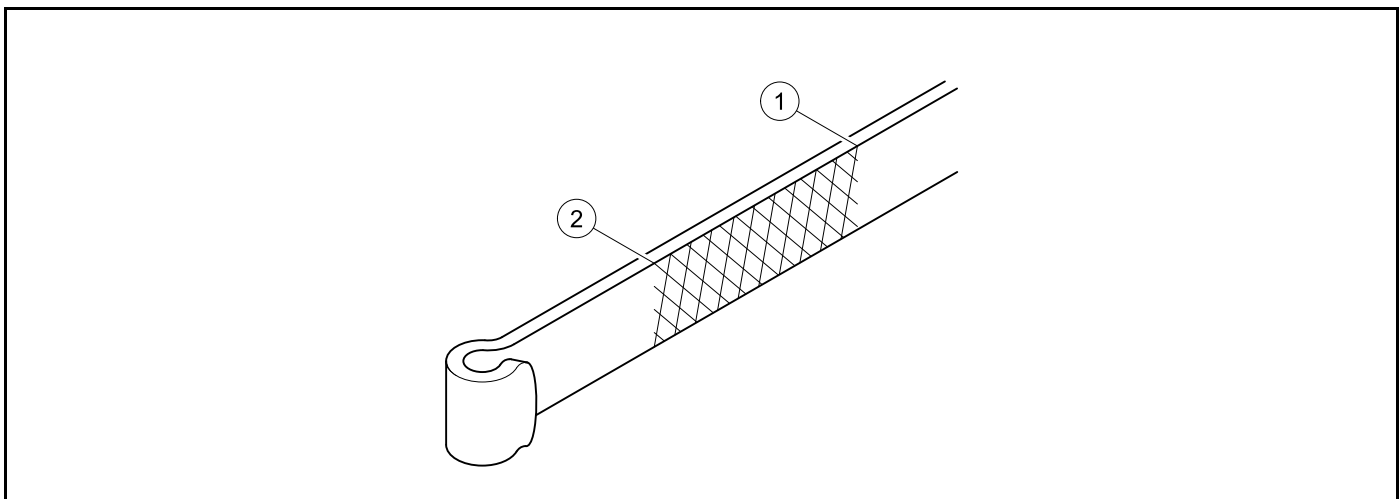

Figure 10-10 Dipstick Indicators

3. Install the dipstick.

## REFUEL

### **⚠ DANGER**

- Fuel is flammable and explosive. Do not add fuel with the key switch set to ON. Before fuel is added, turn the key switch to OFF.

DANGER CONTINUED ON NEXT PAGE

**⚠ DANGER**

- Fuel is flammable and explosive. Do not fill the fuel tank when the engine is on or hot. Wait for the engine temperature to decrease before fuel is added.
- Fuel is flammable and explosive. Do not operate the vehicle when fuel is spilled. Correctly clean the spilled fuel.
- Fuel is toxic. Do not siphon fuel from the vehicle.
- Fuel is toxic. Keep fuel out of reach of children.
- Fuel is flammable and explosive. Keep the fuel in an approved fuel container. Keep the fuel container in a ventilated area away from sparks and heat sources.
- Fuel is flammable and explosive. To avoid electric arc caused by static electricity, the fuel storage/pumping device must be grounded. If the pump is not grounded, the vehicle must be grounded to the pump before and during the fueling operation.

**CAUTION**

- A fuel with an alcohol content that exceeds 10% by volume (like E15 and E85) will cause vehicle damage and void the warranty. Only use the recommended fuel type.

Before the fuel is added:

- Disable the vehicle.

To remove the air filter:

1. Turn the key to OFF.
2. Let the engine cool.
3. Remove the fuel fill cap.
4. Fill the fuel tank with the recommended fuel.
5. Install and tighten the fuel fill cap.

**LIFT THE VEHICLE**

---

**LIFT THE FRONT OF THE VEHICLE****⚠ WARNING**

- Lifting the vehicle with cargo can cause property damage, serious personal injury, or death. Remove all cargo from the cargo bed before the vehicle is lifted.

Before the vehicle is lifted:

- Disable the vehicle.
- Disconnect the battery.

- Use a jack and jack stands rated for the vehicle.

To lift the front of the vehicle:

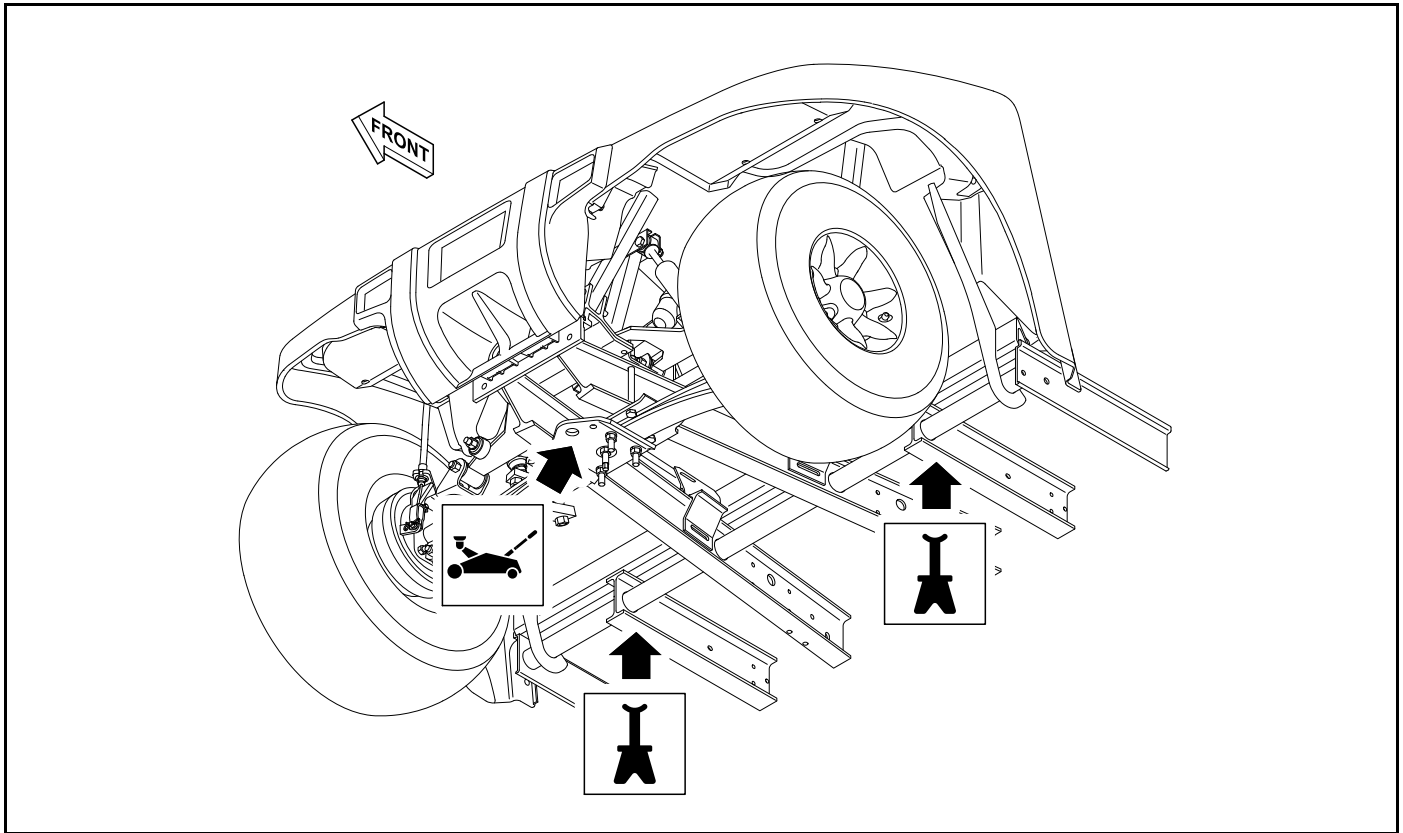

Figure 10-11 Lift The Front

1. Place the jack in the center of the lift point.
2. Lift the front of the vehicle.
3. Put jack stands under the frame rails.
4. Lower the vehicle onto the jack stands.

## LIFT THE REAR OF THE VEHICLE

### **⚠ WARNING**

- **Lifting the vehicle with cargo can cause property damage, serious personal injury, or death. Remove all cargo from the cargo bed before the vehicle is lifted.**

Before the vehicle is lifted:

- Disable the vehicle.
- Disconnect the battery.
- Use a jack and jack stands rated for the vehicle.

To lift the rear of the vehicle:

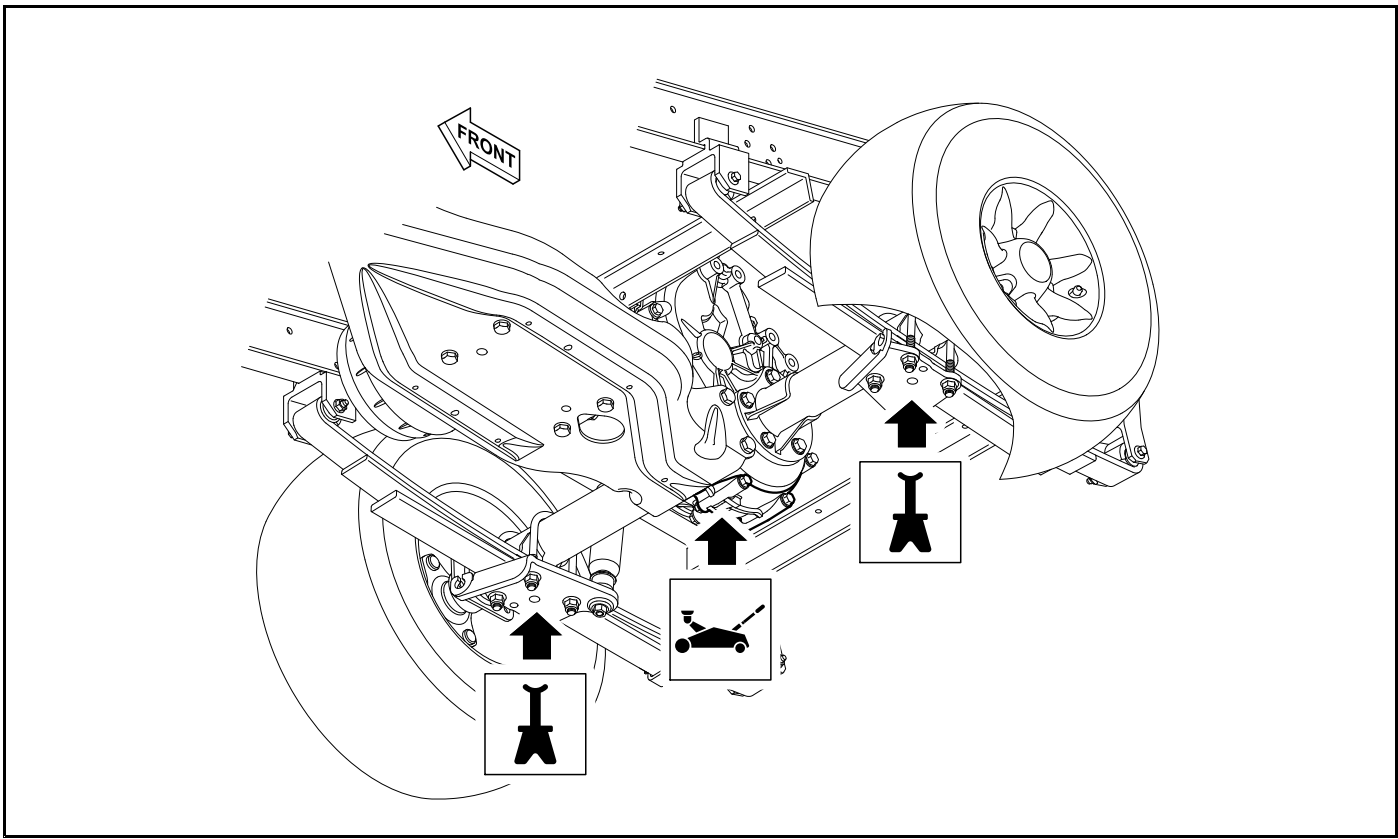

Figure 10-12 Lift The Rear

1. Place the jack in the center of the lift point.
2. Lift the rear of the vehicle.
3. Put jack stands under the frame rails.
4. Lower the vehicle onto the jack stands.

### LOWER THE FRONT OF THE VEHICLE

Before the vehicle is lowered:

- Use a jack rated for the vehicle.

To lower the front of the vehicle:



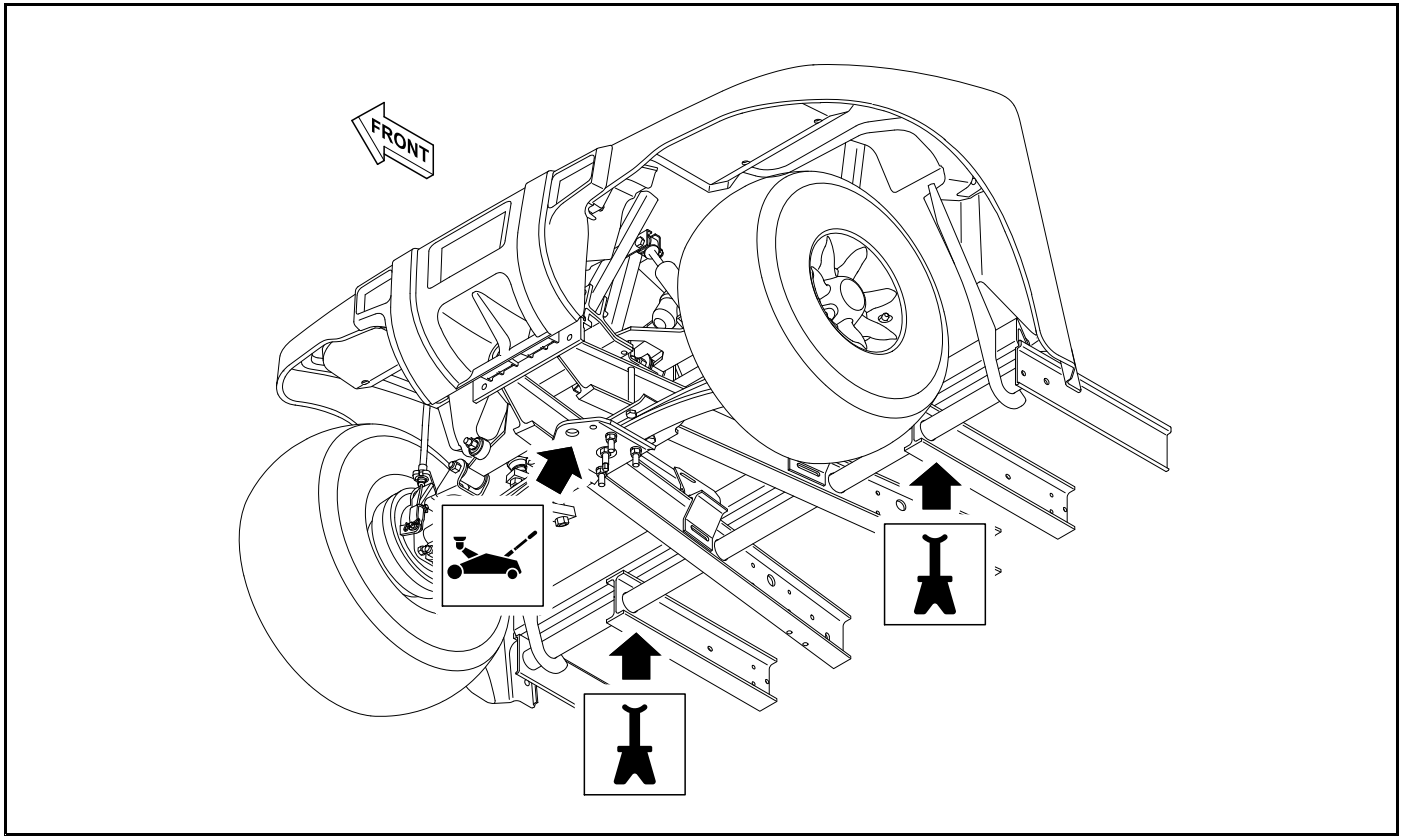

Figure 10-13 Lower The Front

1. Place the jack in the center of the lift point.
2. Lift the vehicle off of the jack stands.
3. Remove the jack stands.
4. Lower the vehicle.

### LOWER THE REAR OF THE VEHICLE

Before the vehicle is lowered:

- Use a jack rated for the vehicle.

To lower the rear of the vehicle:

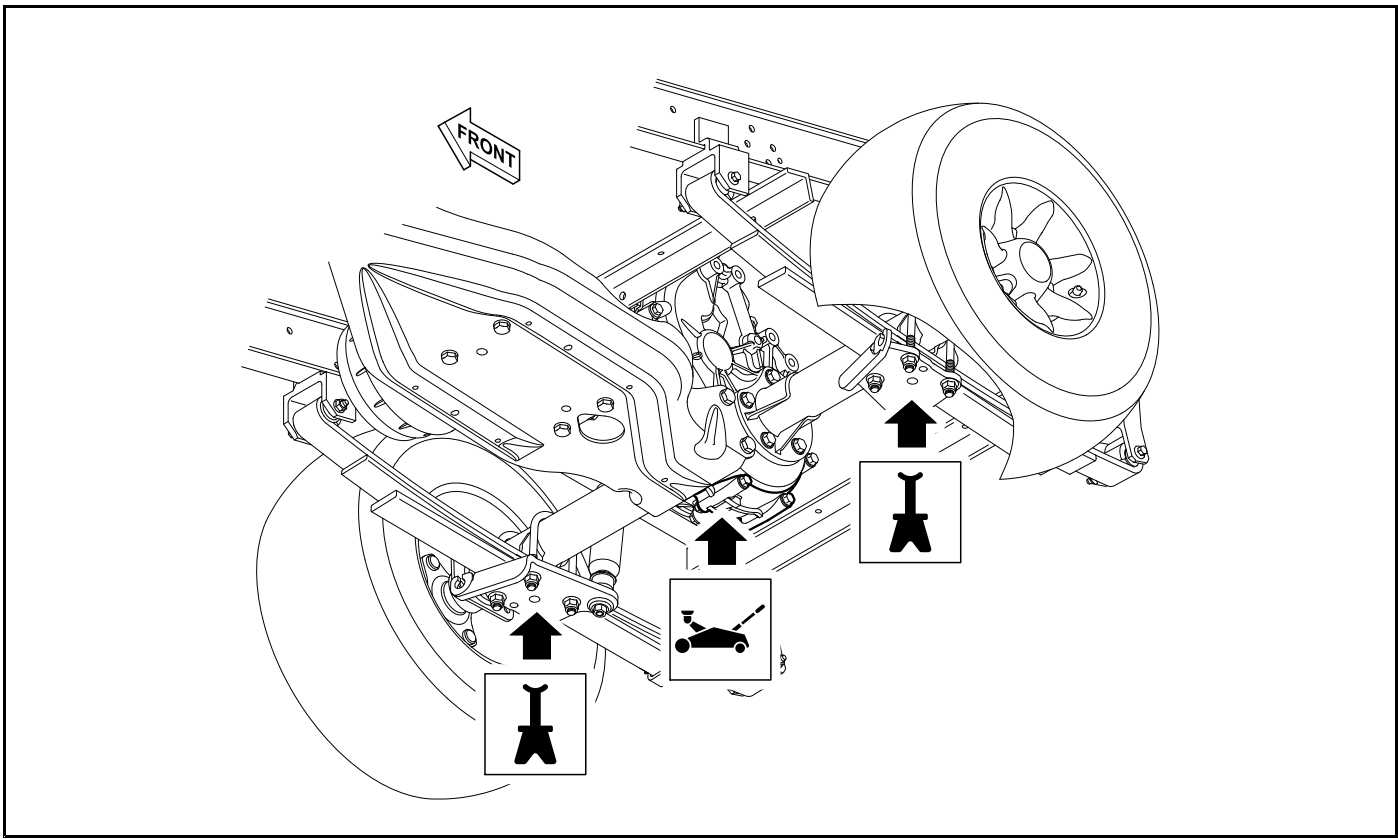

Figure 10-14 Lower The Rear

1. Place the jack in the center of the lift point.
2. Lift the vehicle off of the jack stands.
3. Remove the jack stands.
4. Lower the vehicle.

## SPARK PLUG

### SPARK PLUG REMOVAL

Before the spark plug is removed:

- Disable the vehicle.
- Disconnect the battery.

To remove the spark plug:

1. Clean the spark plug area.
2. Disconnect the spark plug wire (1) (**Figure 10-15, Page 10-19**).

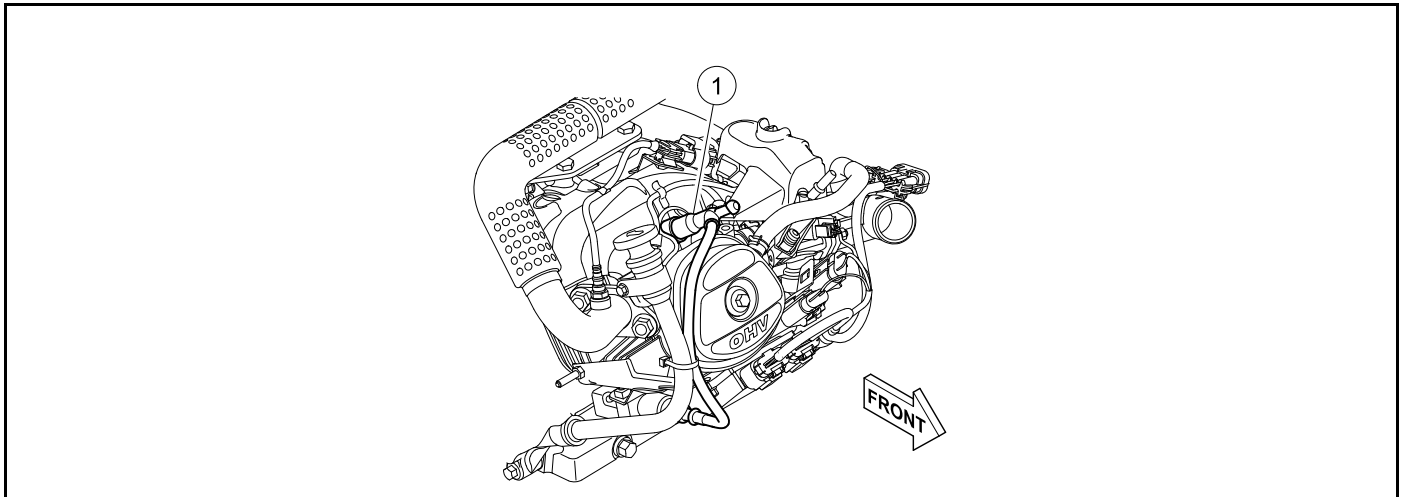

Figure 10-15 Spark Plug Wire Disconnect

3. Use a spark plug socket to remove the spark plug.

### SPARK PLUG INSPECTION

1. Use a wire brush to clean the electrodes (1).

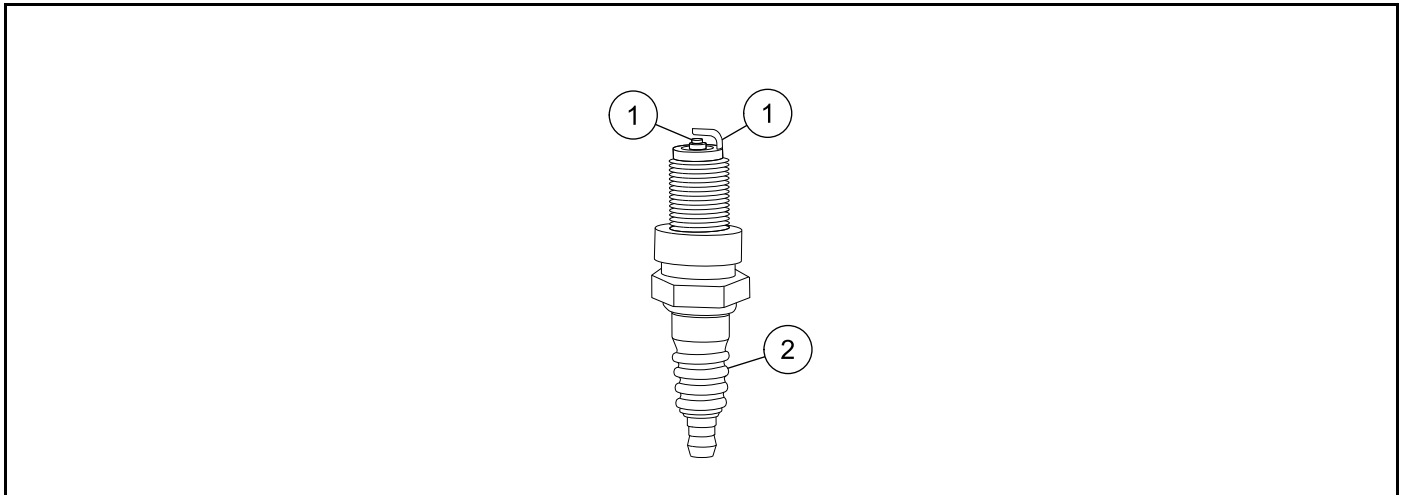

Figure 10-16 Spark Plug Inspection

2. Examine the spark plug electrodes for corrosion and damage.
3. Examine the spark plug insulator (2) for cracks.
4. Replace the spark plug if corrosion, damage, or cracks are found.

### SPARK PLUG GAP

1. Use a spark plug gap tool to measure the spark plug gap.
2. Adjust the ground electrode (1) and set the spark plug gap to 0.044 in (1.11 mm).

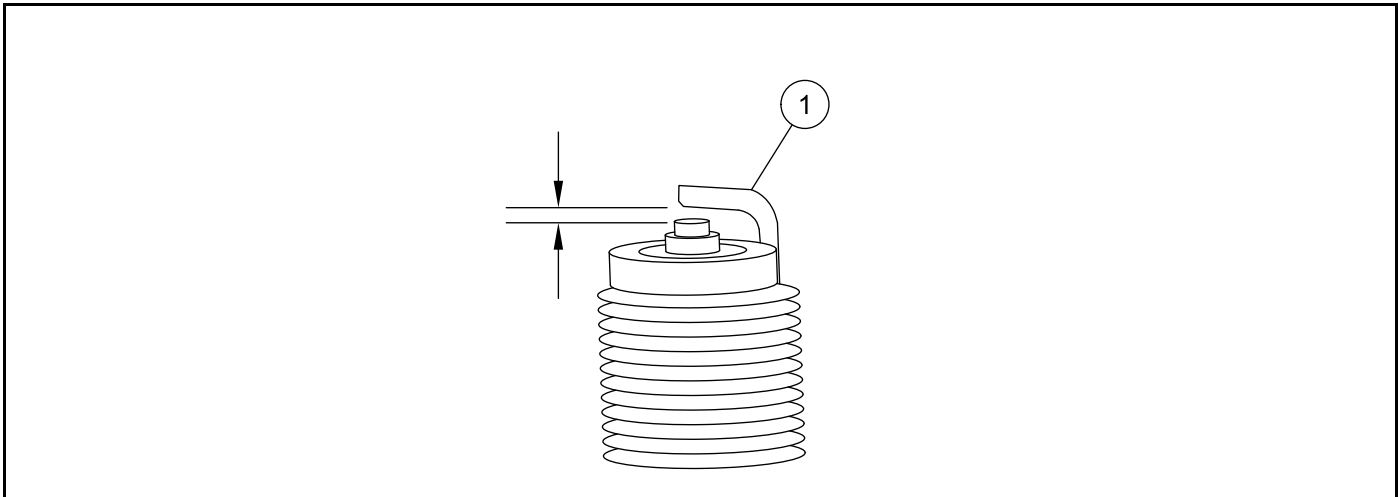

Figure 10-17 Spark Plug Gap

## SPARK PLUG INSTALLATION

1. Apply a thin layer of high temperature anti-seize lubricant to the spark plug threads.
2. Use a spark plug socket to install and tighten the spark plug to 20 lb·ft (27 N·m).
3. Connect the spark plug wire (1) (**Figure 10-18, Page 10-20**).

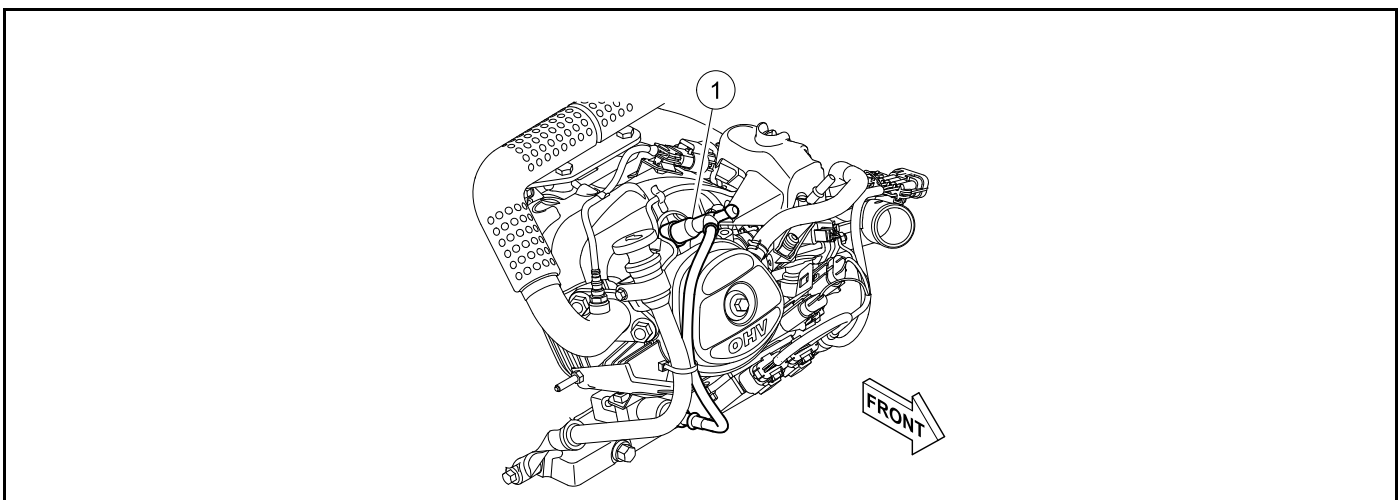

Figure 10-18 Spark Plug Wire Connect

4. Connect the battery.

## VALVE CLEARANCE CHECK AND ADJUSTMENT

See Kohler Engine Service Manual.

## **⚠ DANGER**

- See General Warnings on page 1-1.

## **⚠ WARNING**

- See General Warnings on page 1-1.

## GENERAL INFORMATION

---

### **⚠ WARNING**

- To prevent damage to the ECU, never mix the black and gray connectors that attach to it. The black connector is tethered to the ECU mounting plate to help avoid installing it in the gray port.

This section contains the information required to correctly troubleshoot the EFI gas vehicle. In addition to troubleshooting, this section contains general information on the electrical system and the circuits of the electrical system.

## ACCESSORIES

For powered accessories that do not need to be controlled by the key switch, use the red/white and black/yellow wires with female, quick-disconnect terminals located behind the instrument panel.

## LOW OIL WARNING LIGHT

### **CAUTION**

- Failure to add oil immediately when the low oil warning light stays on may result in permanent engine damage.

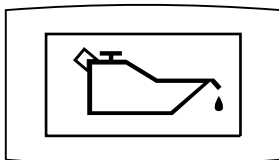

The low oil warning light gives a visual indication of an oil level problem.

Figure 11-1 Low Oil Warning Light

Low oil warning light

continued on next page

STATUS	CONDITION
OFF	Normal Operation
ON	When possible: <ol style="list-style-type: none"> <li>1. Stop the vehicle.</li> <li>2. Turn the key to OFF.</li> <li>3. Examine the engine oil level.</li> <li>4. Add engine oil as necessary.</li> <li>5. If the low oil level warning light stays on, have a trained technician examine the vehicle.</li> </ol>

## MALFUNCTION INDICATOR LIGHT

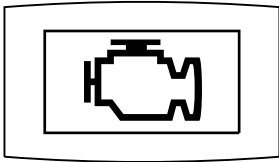

The malfunction indicator light (MIL) gives a visual indication of an engine fault. When the key switch is set to ON, the MIL will turn on for 3 seconds.

If an engine fault is sensed, the MIL will stay on. **See the Kohler Engine Service Manual for more information.**

## GROUND LOCATIONS

Electrical grounds are located at the following areas:

- **Below the Battery:** The battery, starter/generator, voltage regulator and main wire harness are all grounded to the chassis on the frame rail below the battery.
- **In Front of Engine:** The engine is grounded to the chassis cross-member.
- **Top of Fuel Tank:** The fuel tank is grounded to the chassis through the main wire harness.

## FEATURES OF THE ELECTRONIC FUEL INJECTION (EFI) SYSTEM

- Closed-loop system, oxygen (O<sub>2</sub>) sensor included
- Controls fuel pump, fuel injector, malfunction indicator light (MIL)
- Inputs: Temperature/Manifold Absolute Pressure (TMAP), Throttle Position Sensor (TPS), oxygen (O<sub>2</sub>) sensor, crank sensor, ignition timing, cylinder head temp
- Separate EFI wire harness

## TROUBLESHOOTING GUIDE

The following troubleshooting guides will be helpful in identifying operating difficulties should they occur. The guides include the symptom, probable cause(s) and suggested checks. The procedures used in making these checks can be found in the referenced sections of the maintenance and service manual.

**GASOLINE POWERTRAIN**

<b>TROUBLESHOOTING GUIDE</b>		
<b>SYMPTOM</b>	<b>POSSIBLE CAUSES</b>	<b>CORRECTIVE ACTION</b>
Starter fails to operate.	Maintenance/Operate switch is in the MAINTENANCE position	Set the Maintenance/Operate switch to OPERATE
	Fuse is blown	See the Fuses Test Procedure
	Battery is dead	See the Battery Test Procedure
	Starter control circuit is not operating	See the Key Switch (Start Circuit) Test Procedure
	Starter/generator failed	See the Starter/Generator (Starter Function) Test Procedure
	Starter solenoid failed	See the Solenoid Test Procedure
	Accelerator pedal limit switch failed	See the Accelerator Pedal Limit Switch (Pedal-Start) Test Procedure
	Key switch failed	See the Key Switch (Start Circuit) Test Procedure
	Neutral lockout limit switch failed	See the Neutral Lockout Limit Switch (Pedal-Start) Test Procedure
	Loose or broken wire in starter/generator circuit	See Starter/Generator in the Electrical Components Section
	Cylinder and/or crankcase flooded with fuel	See the Fuel System Section
Starter/generator does not charge battery.	Loose or broken wire in the starter/ generator circuit	See the Starter/Generator (Generator Function) Test Procedure
	Generator field coil is shorted	See the Starter/Generator (Generator Function) Test Procedure
	Brushes are worn or commutator is dirty	See Starter/Generator in the Electrical Components Section
	Starter/generator belt is loose or slipping	See Belt Tension Adjustment For EFI Engines in the Electrical Components Section
	Voltage regulator failed	See the Voltage Regulator Test Procedure
	Battery failed	See the Battery Test Procedure
Transmission does not engage or disengage smoothly.	Transmission shifter linkage is binding or is out of adjustment	See the Transaxle (ED65) Section
	Insufficient (low) level of lubricant or wrong type of lubricant in transmission	See the Transaxle (ED65) Section
	Internal gears are damaged or worn	See the Transaxle (ED65) Section
	Dog clutch jammed or broken	See the Transaxle (ED65) Section

**TABLE CONTINUED ON NEXT PAGE**

TROUBLESHOOTING GUIDE		
SYMPTOM	POSSIBLE CAUSES	CORRECTIVE ACTION
Excessive vehicle vibration.	Engine mounting nuts or bolts are loose	See the Engine (Kohler ECH440) Section
	Snubber on frame is worn or damaged	See the Engine (Kohler ECH440) Section
	Loose muffler mounting hardware	See the Exhaust System: Gasoline Vehicles Section
	Damaged drive belt or starter belt	See the Clutches: Gasoline Vehicles Section
	Damaged drive clutch	See the Clutches: Gasoline Vehicles Section
	Damaged starter/generator pulley	See Starter/Generator in the Electrical Components Section
	RPM setting is incorrect	See Engine RPM Adjustment in the Fuel System Section
Clutches do not shift smoothly.	Drive belt is worn, cracked, glazed, or frayed	See the Clutches: Gasoline Vehicles Section
	Drive clutch malfunction	See the Clutches: Gasoline Vehicles Section
	Governor is sticking	See the Transaxle (ED65) Section
Engine won't stop running.	Kill circuit wire is disconnected from the ignition coil	See the Kill Limit Switch (Pedal-Start) Test Procedure
	Accelerator pedal linkage out of adjustment causing engine kill limit switch not to activate	See the Fuel System: Gasoline Vehicles Section
	Fuel mixture is too lean; check EFI	See the Fuel System: Gasoline Vehicles Section
	Throttle stop screw out of adjustment at governor arm	See the Fuel System: Gasoline Vehicles Section



---

## **ELECTRICAL SYSTEM**

---

The electrical system on the gasoline vehicle is 12 volts DC with negative (–) ground to frame, and consists of the following circuits that are easily identified:

- Starter Circuit
- Generator Circuit
- Electronic Fuel Injection Circuit
- Engine Ignition Circuit
- Engine Kill Circuit
- Reverse Buzzer Circuit
- Low Oil Warning Light Circuit
- Neutral Lockout Circuit
- Fuel Pump Circuit
- Fuel Gauge and Sending Unit Circuit
- Hour Meter Circuit
- Lighting Circuit

Recognizing and understanding the function of each of these circuits will help to quickly isolate the source of an electrical problem. Use the appropriate test procedure to correct the electrical problem. See Test Procedures.

For a complete wiring diagram, see the Wiring Diagrams for Pedal-Start or Key-Start vehicles.

## TEST PROCEDURES

---

Using the following procedures, the entire electrical system can be tested without major disassembly of the vehicle.

### **⚠ WARNING**

- If wires are removed or replaced, make sure wiring and wire harness is properly routed and secured. Failure to properly route and secure wiring could result in vehicle malfunction, property damage, personal injury, or death.

For some tests, the electrical component box cover must be removed to gain access to the various components that are mounted inside the component box. **See following WARNING.**

### **⚠ WARNING**

- Shorting of battery terminals can cause personal injury or death.

After test procedures are completed, be sure to replace the cover. **See following CAUTION.**

### **CAUTION**

- Exposure to water and the elements may damage electrical components. Do not operate vehicle without the cover properly installed.

## TESTING BASICS

- Battery voltage will be referenced throughout the test procedures. Battery voltage is accessed in the Battery test procedure.
- The Maintenance/Operate switch, in the MAINTENANCE position, grounds and kills the ignition if the Forward/Neutral/Reverse control (FNR) is placed in F or R.
- The key switch powers the ECU, fuel pump, solenoid, lights, and the connected car device.
- The 2-amp fuse is powered by the key switch via the 10-amp ATM fuse and carries battery voltage to the connected car device.
- The term “back-probe” refers to probing the side of a connector that the wire enters. This is usually done when the connector must remain connected to a device. An alternative method is to use an insulation-piercing probe. **See following CAUTION.**

### **CAUTION**

- Be careful not to damage the wire or terminal when back-probing.
- When testing voltage, the battery must remain connected.
- When testing voltage, unless specifically directed to do otherwise in a procedure, connect the black (–) probe of the multimeter to chassis ground.
- When testing resistance or continuity, turn off power to the circuit being measured and discharge any capacitor(s). The presence of voltage can cause inaccurate readings.

## Index of Test Procedures

1 – Battery

- 2 – Fuses
- 3 – Ground Cables
- 4 – Key Switch (Start Circuit)
- 5 – Key Switch (Engine Kill Circuit)
- 6 – Accelerator Pedal Limit Switch
- 7 – Solenoid
- 8 – Maintenance/Operate Switch
- 9 – Neutral Lockout Limit Switch
- 10 – Kill Limit Switch
- 11 – Starter/Generator (Generator Function)
- 12 – Starter/Generator (Starter Function)
- 13 – Voltage Regulator
- 14 – Ignition Spark
- 15 – Reverse Buzzer and Reverse Buzzer Limit Switch
- 16 – Malfunction Indicator Light (MIL)
- 17 – Low Oil Warning Light (LED)
- 18 – Battery Test (Under Load)
- 19 – Fuel Pump
- 20 – Fuel Level Sending Unit
- 21 – Fuel Gauge
- 22 – Hour Meter
- 23 – Headlight Switch
- 24 – Voltage at Headlight Socket
- 25 – Voltage Limiter
- 26 – 4-Pin Connector (for Connected Car Device)

## TEST PROCEDURE 1 – Battery

See General Warnings on page 1-1.

### **⚠ DANGER**

- Due to the danger of an exploding battery, wear a full face shield and rubber gloves when working near a battery.
- Battery – Explosive gases! Do not smoke. Keep sparks and flames away from the vehicle and service area. Ventilate when charging or operating vehicle in an enclosed area. Wear a full face shield and rubber gloves when working on or near batteries.
- Battery – Poison! Contains acid! Causes severe burns. Avoid contact with skin, eyes, or clothing. Antidotes:
  - External: Flush with water. Call a physician immediately.
  - Internal: Drink large quantities of milk or water. Follow with milk of magnesia or vegetable oil. Call a physician immediately.
  - Eyes: Flush with water for 15 minutes. Call a physician immediately.

**NOTE:** The battery must be properly maintained and fully charged in order to perform the following test procedures. Battery maintenance procedures can be found in the Electrical Components: Pedal-Start Gas Vehicle section.

1. Disable the vehicle.
2. Set the Maintenance/Operate switch to MAINTENANCE.
3. Check for loose or corroded battery terminal connections.
4. Disconnect the battery.
5. Clean the battery terminals and connections. Replace the connections and wires as necessary.
6. Connect the battery.

### **Voltage Test**

1. Set the multimeter to 20 VDC.
2. Put the red (+) probe on the positive (+) battery post.
3. Put the black (-) probe on the black (-) battery post.
  - 3.1. If the voltage is more than 12.4 volts, the battery is good.
  - 3.2. If the voltage is less than 12.4 volts, charge the battery. Go to the next step.
    - 3.2.1. If the voltage does not reach 12.4 volts after charging, replace the battery.

### **Load Test**

1. Make a note of the ambient temperature.
2. Connect a 160-ampere load tester to the battery posts.
3. Turn the switch on the load tester to the ON position.
4. Wait for 15 seconds. Read the battery voltage. Compare the battery's voltage reading with the following table.

<b>IF TEMPERATURE IS</b>	<b>MINIMUM CRANKING VOLTAGE</b>
70 °F (20 °C and above)	9.6 V
60 °F (16 °C)	9.5 V
50 °F (10 °C)	9.4 V
40 °F (4 °C)	9.3 V
30 °F (-1 °C)	9.1 V
20 °F (-7 °C)	8.9 V
10 °F (-12 °C)	8.7 V
0 °F (-18 °C)	8.5 V

5. If the battery voltage is less than the minimum cranking voltage, replace the battery. Go to next step.
- 5.1. If the electrical problem continues, test the electrical circuits.
6. If the battery voltage is the minimum cranking voltage or higher, test the electrical circuits.

**TEST PROCEDURE 2 – Fuses**

See General Warnings on page 1-1.

**⚠ WARNING**

- Failure to use properly rated fuse can result in a fire hazard.

**NOTE:** These vehicles predominately use a combination of ATC-style and ATM-style blade fuses. A single ABC-style glass fuse is used for the Guardian/Visage 4-pin connector that is labeled “V3 circuit” on the harness.

*This is a voltage test. It can be performed relatively easily on ATC-style and ATM-style fuses. A voltage test can be performed on the ABC-style glass fuse if insulation-piercing probes are used. Otherwise, the ABC-style will have to be removed to visually inspect or check using a continuity test.*

*ATC-style blade fuses are located inside the electrical component box near the battery.*

*ATM-style blade fuses are located on the main wire harness in front of the engine.*

*The ABC-style glass fuse is located on the main wire harness underneath the front cowl.*

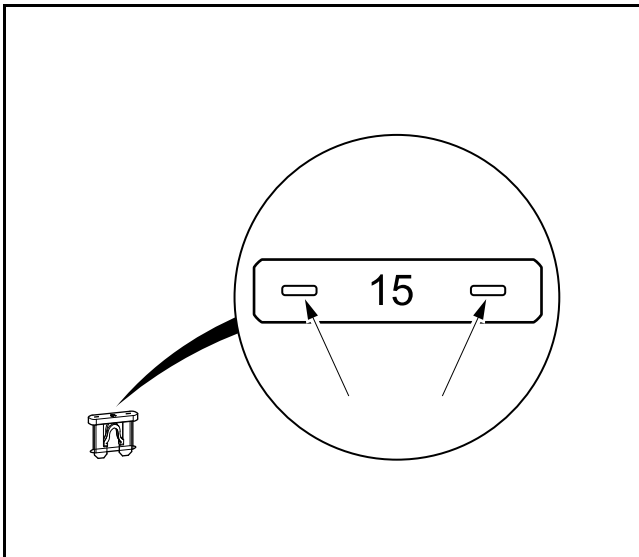

2784

**Figure 11-2 Testing the ATC and ATM-style Blade Fuse**

1. If necessary, see Testing Basics.
2. Access the fuse but do not remove it.
3. **10-amp ATC and ATM Fuses Only:** With the battery and solenoid connected:
  - 3.1. Probe the two, small metal contacts on the top of the fuse (**Figure 11-2, Page 11-10**).
  - 3.2. Each contact should show battery voltage.
  - 3.3. If only one side shows battery voltage, replace fuse.
  - 3.4. If neither side of a fuse shows battery voltage, inspect the following locations:
    - Wire connections at the solenoid.

4. **5-amp ATM Fuse Only:** With the key switch in the ON position:
  - 4.1. Probe the two, small metal contacts on the top of the fuse (**Figure 11-2, Page 11-10**).
  - 4.2. Each contact should show battery voltage.
  - 4.3. If only one side shows battery voltage, replace fuse.
  - 4.4. If neither side of a fuse shows battery voltage, inspect the following locations:
    - 12-pin dash wire harness connector, key switch and sonic weld 3.
  
5. **2-amp ABC Glass Fuse Only:** With the key switch in the ON position:
  - 5.1. Probe the wire on each side of the fuse with insulation-piercing probes.
  - 5.2. Each probe should show battery voltage.
  - 5.3. If only one side shows battery voltage, replace fuse.
  - 5.4. If neither side of a fuse shows battery voltage, inspect the following locations:
    - 5-amp ATM fuse, 12-pin dash wire harness connector, key switch and sonic weld 3.

## TEST PROCEDURE 3 – Ground Cables

See General Warnings on page 1-1.

**NOTE:** This is a continuity test for the main ground wire of the vehicle. An additional ground wire is located on top of the fuel tank.

1. If necessary, see Testing Basics.
2. Disconnect battery and spark plug wire.
3. Check the following wires and cables for clean, tight connections and continuity (**Figure 11-3, Page 11-12**):
  - Check the starter/generator ground cable (black wire) from A1 terminal to chassis.
  - Check the battery ground cable from the disconnected terminal to chassis.
  - Check the engine ground cable from engine block to chassis.
4. The reading should be continuity. If the reading is incorrect, clean and tighten cable connections. If the connections are good and the reading is incorrect, repair or replace the wire or cable.

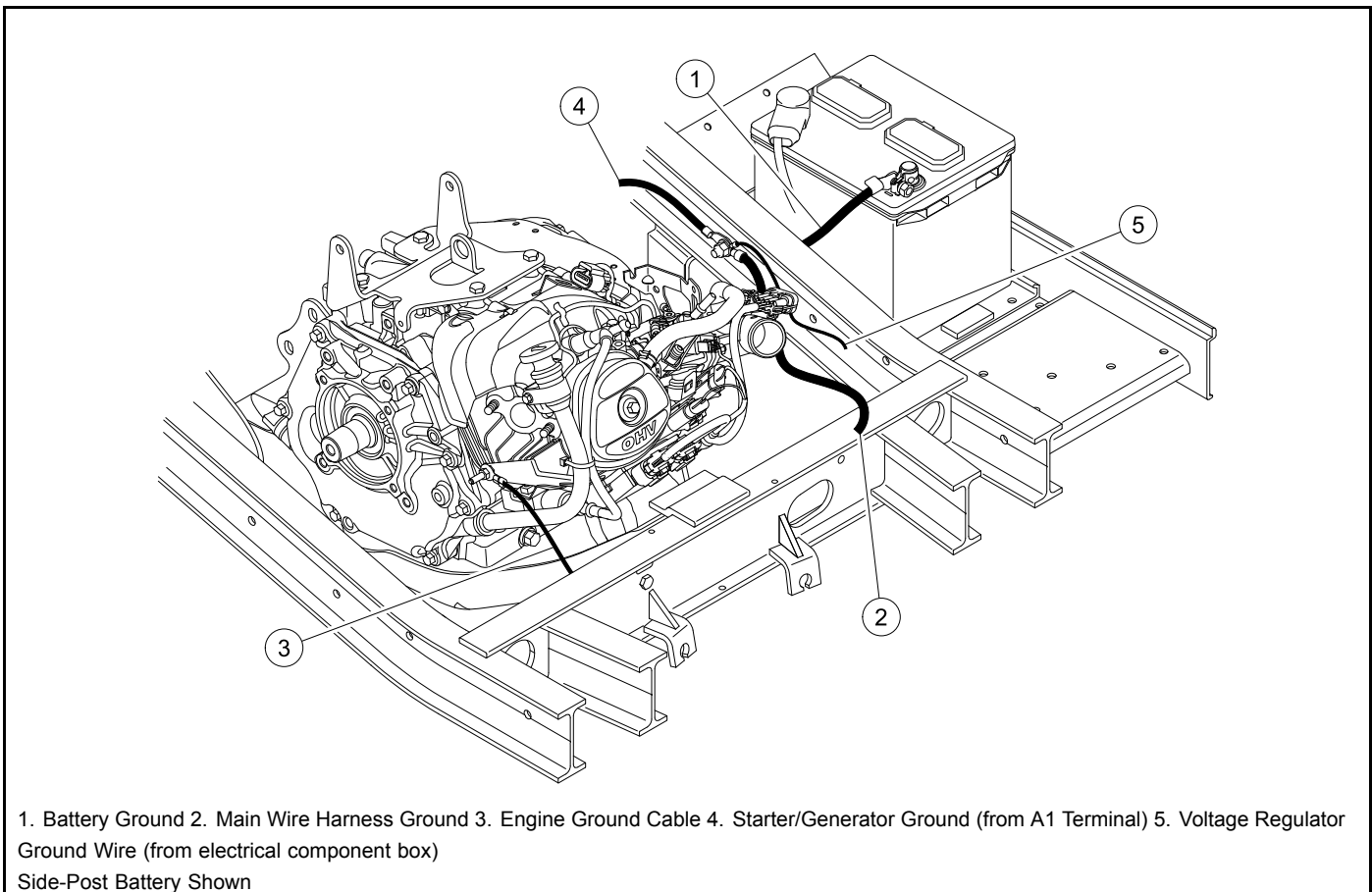

**Figure 11-3 Ground Wires and Cables**



---

## **TEST PROCEDURE 4 – Key Switch (Start Circuit)**

**See General Warnings on page 1-1.**

**NOTE:** *This is a voltage test.*

*The key switch provides power and KEY INPUT to the ECU.*

1. If necessary, see Testing Basics.
2. Remove the instrument panel. Do not disconnect the wires.
3. With the key switch in the OFF position:
  - The green wire should show battery voltage coming to the switch.
  - The brown/white wire should show zero (0) volts. If it shows battery voltage, the switch has failed CLOSED and must be replaced.
4. With the key switch in the ON position:
  - The brown/white wire should show battery voltage. If it does not show battery voltage, the switch has failed OPEN and must be replaced.

**TEST PROCEDURE 5 – Key Switch (Engine Kill Circuit)**

See General Warnings on page 1-1.

**NOTE:** This is a continuity test.

1. If necessary, see Testing Basics.
2. Disconnect battery and spark plug wire.
3. Remove the instrument panel. See Instrument Panel Removal.
4. Disconnect the wires from the (+M) and (–M) terminals of the key switch.
5. Set the multimeter to 200 Ohm (1) (**Figure 11-4, Page 11-14**).
6. Put the red (+) probe on the (+M) terminal.

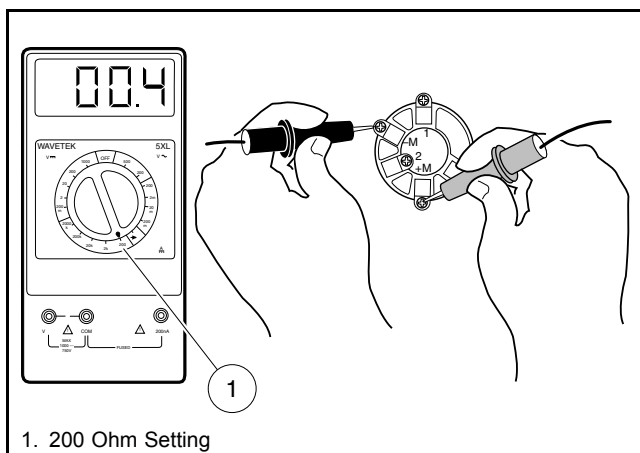

1337

**Figure 11-4 Key Switch Test – Engine Kill Circuit**

7. Put the black (–) probe on the (–M) terminal.
8. With the key switch OFF, the reading should be continuity.
  - 8.1. If there is no continuity, replace the key switch.
9. With the key switch ON, the reading should be no continuity.
  - 9.1. If there is continuity, replace the key switch.
10. Connect the wires to the key switch. Make sure wires are connected correctly and are tight. If they are not, rewire or tighten as necessary.
11. Install the instrument panel. See Instrument Panel Installation.

## TEST PROCEDURE 6 – Accelerator Pedal Limit Switch

See General Warnings on page 1-1.

**NOTE:** This is a continuity test.

The accelerator pedal limit switch (1) is the top switch located in the electrical component box (**Figure 11-5**). There is a green wire and a pink wire connected to this limit switch.

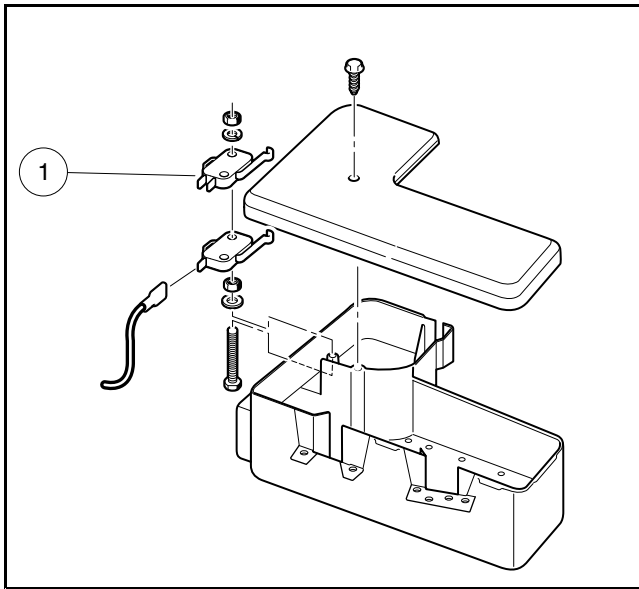

2948B

**Figure 11-5 Accelerator Pedal Limit Switch**

1. If necessary, see Testing Basics.
2. Check for proper wiring and tight connections. See Wiring Diagrams.
3. Disconnect the battery.
4. Set the key switch to OFF.
5. Set the Forward/Neutral/Reverse control (FNR) to N.
6. Make sure the accelerator pedal is in the up position.
7. Set the multimeter to 200 ohms.
8. Put the red (+) probe on the common (COM) terminal (green wire) of the accelerator pedal limit switch.
9. Put the black (-) probe on the normally closed (NC) terminal (pink wire) of the accelerator pedal limit switch.
  - 9.1. If there is continuity, replace the accelerator pedal limit switch.
10. Push the accelerator pedal.
  - 10.1. If there is no continuity, replace the accelerator pedal limit switch.

**TEST PROCEDURE 7 – Solenoid**

See General Warnings on page 1-1.

**NOTE:** This is a resistance and voltage test.

1. If necessary, see Testing Basics.
2. Remove the electrical component box cover (1) (Figure 11-6).

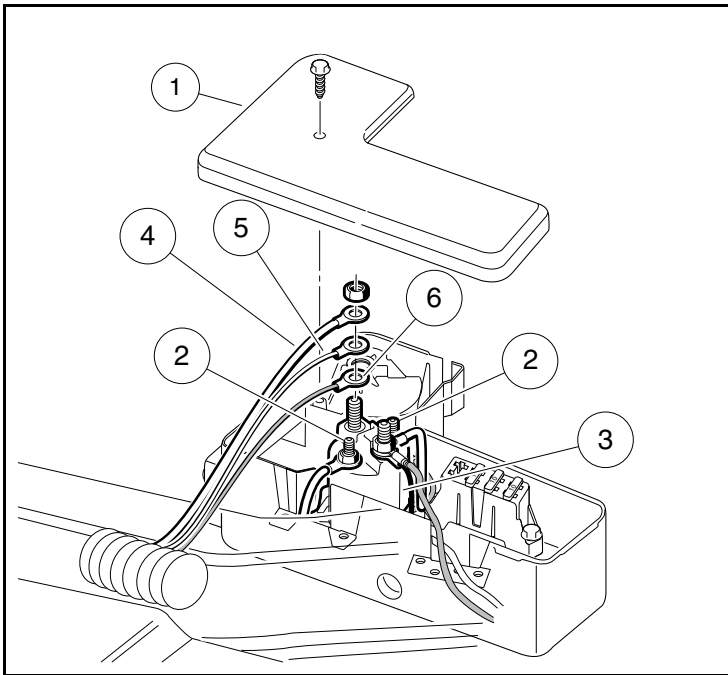

3025B

**Figure 11-6 Solenoid Wires**

3. Make sure that the wires are connected correctly and are tight. If they are not, rewire or tighten as necessary.
4. **Coil Side:** Check the resistance across the small posts (2) of the solenoid (3). The reading should be 14 to 16 ohms. If the reading is not within limits, replace the solenoid.
5. **Contact Side:** Remove the wires (4,5,6) from the large post of the solenoid. Do not allow the wires to touch the frame or other components of the vehicle. Cover the other large post.
6. Set the Forward/Neutral/Reverse control (FNR) to N.
7. Set the Maintenance/Operate switch to MAINTENANCE.
8. Set the key switch to ON.

9. Check the voltage between the empty large post (1) and ground (**Figure 11-7, Page 11-17**).

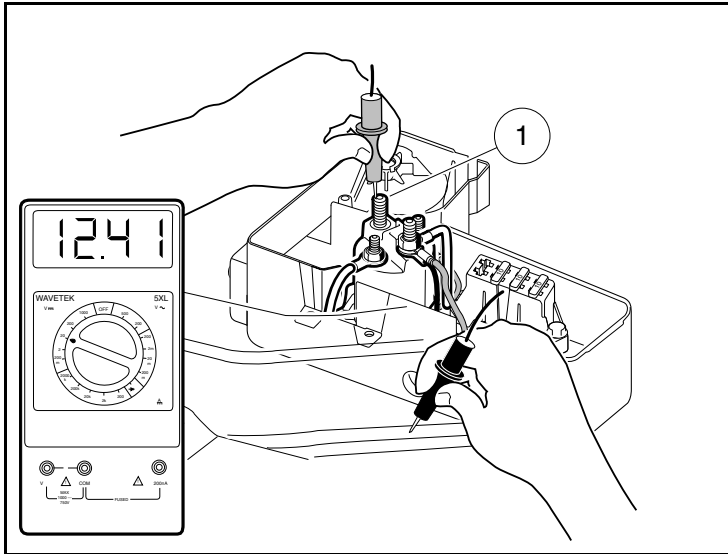

3027B

**Figure 11-7 Solenoid Voltage Test**

10. **With accelerator pedal in the UP position:** The meter should read no voltage.
- 10.1. If there is voltage, replace the solenoid.
11. **With accelerator pedal pressed:** The solenoid should click and the meter should read battery voltage.
- 11.1. If there is no voltage, replace the solenoid.

## TEST PROCEDURE 8 – Maintenance/Operate Switch

See General Warnings on page 1-1.

**NOTE:** This is a continuity test.

The Maintenance/Operate Switch is also known as the Neutral Lockout Switch.

1. If necessary, see Testing Basics.
2. Remove the wires from switch.

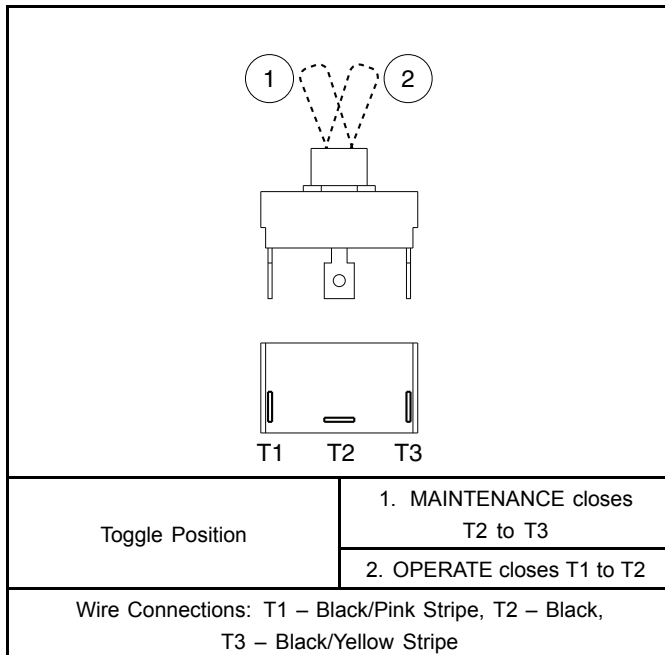

478

**Figure 11-8 Maintenance/Operate Switch Test – for Pedal-Start Vehicles**

3. Set the switch to MAINTENANCE (1) (**Figure 11-8**):
  - 3.1. Check for no continuity between terminals T1 and T2. If there is continuity, replace the switch.
  - 3.2. Check for continuity between terminals T2 and T3. If there is no continuity, replace the switch.
4. Set the switch to OPERATE (2):
  - 4.1. Check for no continuity between terminals T2 and T3. If there is continuity, replace the switch.
  - 4.2. Check for continuity between terminals T1 and T2. If there is no continuity, replace the switch.
5. If the switch works as stated and the MAINTENANCE/OPERATE modes still do not work:
  - 5.1. Check the limit switches.
  - 5.2. Check continuity of the wires involved.

**TEST PROCEDURE 9 – Neutral Lockout Limit Switch**

See General Warnings on page 1-1.

**NOTE:** This is a continuity test.

This switch is located on the transaxle. A black/white wire, a gray wire, and a red wire are connected to this limit switch with a 3-pin connector.

1. If necessary, see Testing Basics.
2. Disconnect the battery and spark plug wire.
3. At the transaxle, disconnect the neutral lockout limit switch three-wire lead from main wire harness.
4. Make sure that the cam lobe on the shift lever is pressing the neutral lockout limit switch as the Forward/Neutral/Reverse control (FNR) is being shifted.
- 4.1. If the neutral lockout switch does not make an audible click as it is pressed, check for wear on the cam lobe and replace shift lever if necessary.
5. Check the following terminals for no continuity with the shift lever released and continuity with the lever engaged (**Figure 11-9, Page 11-19**):

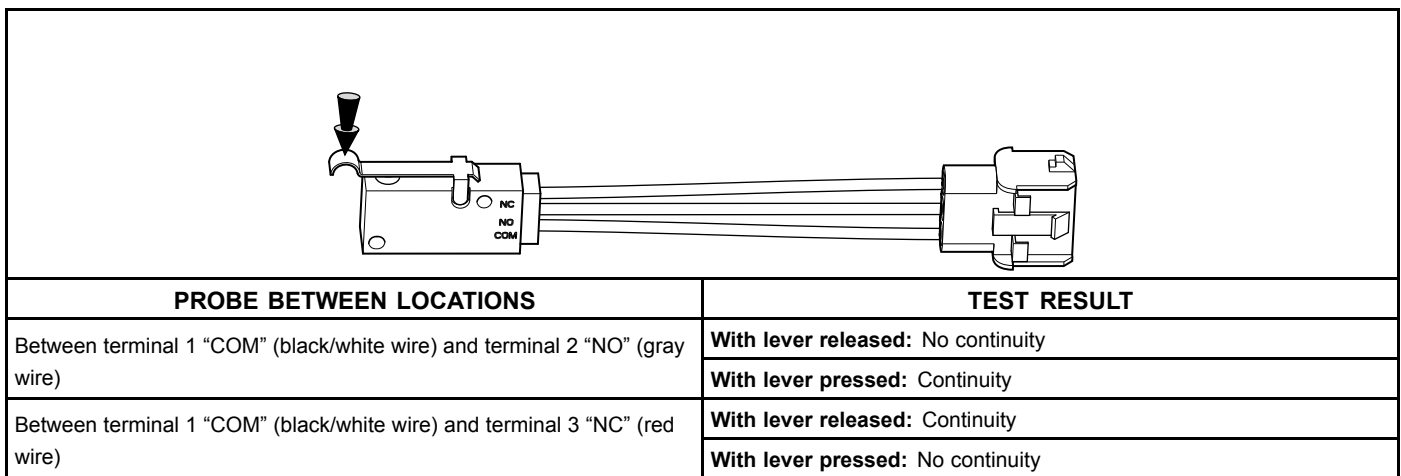

3028

**Figure 11-9 Neutral Lockout Limit Switch Test**

6. If switch does not work as stated in previous step, replace the neutral lockout limit switch.

## TEST PROCEDURE 10 – Kill Limit Switch

See General Warnings on page 1-1.

**NOTE:** This is a continuity test.

The kill limit switch (1) is the lower of the two limit switches located in the electrical component box (**Figure 11-10**). There is a white/black wire and a blue wire connected to this limit switch.

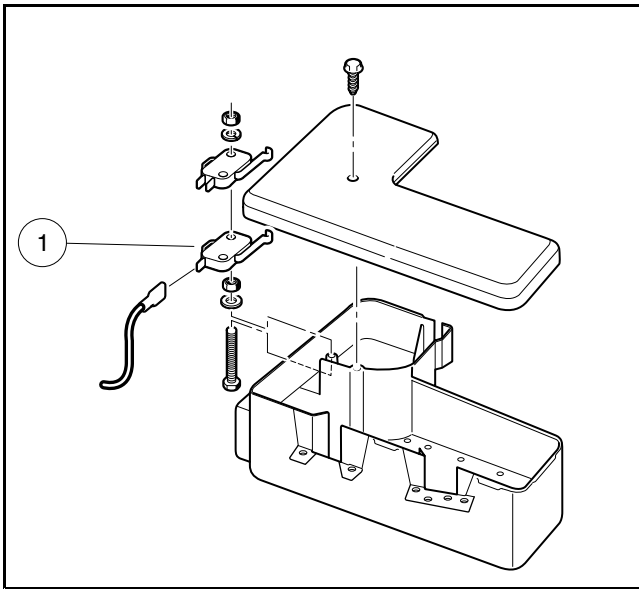

2948C

**Figure 11-10 Kill Limit Switch**

1. If necessary, see Testing Basics.
2. Disconnect the battery and spark plug wire.
3. Remove the electrical component box cover.
4. Check for proper wiring and tight connections. See Wiring Diagrams.
5. Disconnect the wires from the kill limit switch.
6. Put the red (+) probe of the multimeter on the common (COM) terminal (white/black wire) of the kill limit switch.
7. Put the black (–) probe on the normally open (NO) terminal (blue wire) of the kill limit switch.
8. Without the lever (1) pressed, check for continuity (**Figure 11-11**).



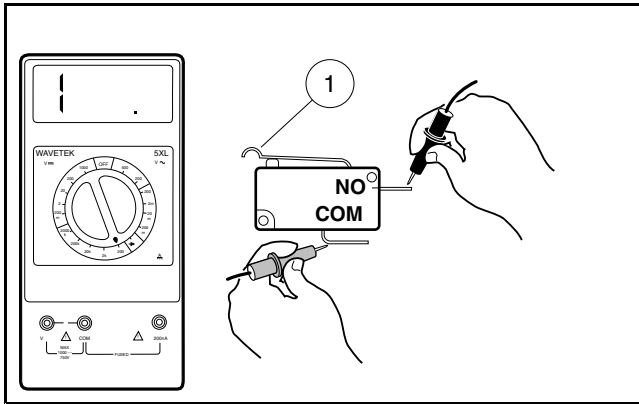

476B

**Figure 11-11 Kill Limit Switch Test**

- 8.1. If there is continuity, replace the kill limit switch.
- 8.2. If there is no continuity, go to the next step.
9. Press the lever and check for continuity.
  - 9.1. If there is continuity, the kill limit switch is good.
  - 9.2. If there is no continuity, replace the kill limit switch.
10. Connect the wires to kill limit switch.

## TEST PROCEDURE 11 – Starter/Generator (Generator Function)

See General Warnings on page 1-1.

**NOTE:** This is a voltage test.

1. If necessary, see Testing Basics.
2. Disable the vehicle.
3. Set the Maintenance/Operate switch to MAINTENANCE.
4. Make sure that the wires are connected correctly and are tight. If they are not, rewire or tighten as necessary.
5. Disconnect the yellow wire (1) from the DF terminal (2) on starter/generator (**Figure 11-12**).

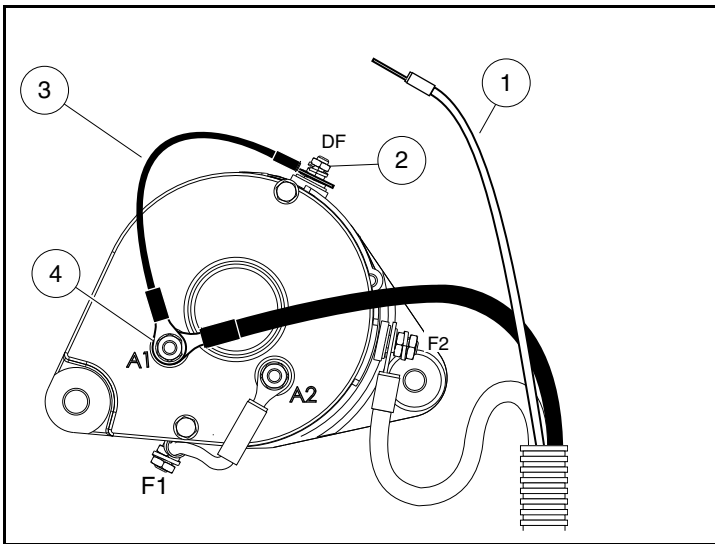

3029B

**Figure 11-12 Jumper Wire Ground – DF to A1**

6. Cover terminal on yellow wire to make sure it will not short to ground.
7. Use a jumper wire (3) to ground DF terminal to A1 terminal (4).
8. Set the multimeter 20 VDC.
9. Put the red (+) probe on the positive (+) post of the battery.
10. Put the black (–) probe on the negative (–) post.
11. Start the engine and run it at full governed speed. The reading should show the voltage rising on the meter.
  - 11.1. If the voltage rises above 15.3 volts DC, test the voltage regulator.
  - 11.2. If the voltage does not rise, do a tear-down inspection of the starter/generator.
12. Remove the jumper wire.
13. Reconnect the yellow wire to the DF terminal on starter/generator.

## TEST PROCEDURE 12 – Starter/Generator (Starter Function)

See General Warnings on page 1-1.

**NOTE:** Observe the following before testing the starter/generator:

- This is only testing continuity.
- Tag the starter/generator wires for identification before disconnecting.
- Remove starter/generator wire from one of the “A” terminals and one of the “F” terminals if testing while starter/generator is in vehicle.
- When disconnecting wires from starter/generator terminals, use a second wrench on the lower nut of the terminal post to hold post steady.
- Scrape a small amount of paint from starter/generator housing (ground) and use this location when testing motor terminals to electrical ground.

MOTOR TERMINALS	CONTINUITY TEST RESULT
A1 to A2 F1 to F2	Continuity
A1 to F1 A1 to F2	No Continuity
A2 to F1 A2 to F2	No Continuity
A1 to Ground A2 to Ground	No Continuity
F1 to Ground F2 to Ground	No Continuity

1. If necessary, see Testing Basics.
2. Disconnect the battery and spark plug wire.
3. Disconnect the wires from all the terminals on the starter/generator.
4. Set the multimeter to 200 Ohms.
5. Put the black (-) probe on the starter/generator housing. Scratch through the finish to ensure a good ground.

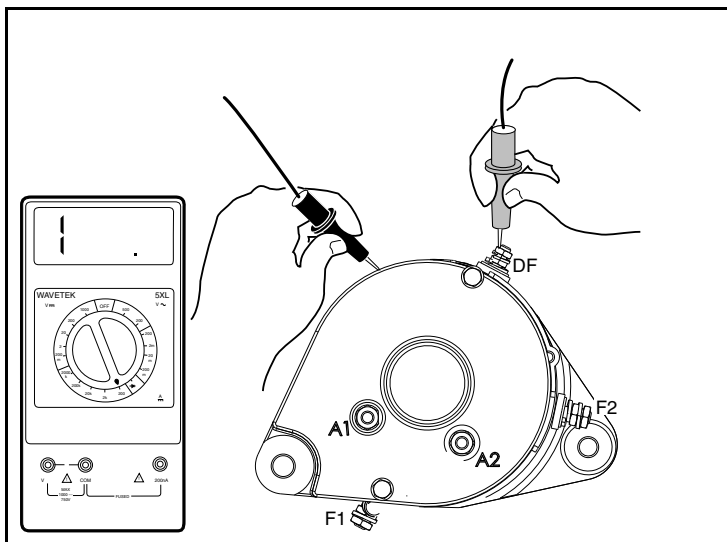

3030B

**Figure 11-13 Check Starter Terminal Continuity**

6. Put the red (+) probe (one at a time) on the A1, A2, F1, F2 and DF terminals. The readings should be no continuity.
  - 6.1. If there is continuity, the starter/generator will need to be removed from the vehicle and disassembled by a qualified technician.
7. Put the red (+) probe on the A1 terminal and the black (-) probe on the A2 terminal. The reading should be continuity.
  - 7.1. If there is no continuity, the starter/generator will need to be removed from the vehicle and disassembled by a qualified technician.

Possible causes:

- A grounded wire in the brush area.

- A grounded armature/commutator.
  - A grounded A1 or A2 terminal.
8. Put the red (+) probe on the F1 terminal and the black (–) probe on the F2 terminal. The reading should be between approximately 0.1 and 0.3 ohms.
- 8.1. If the reading is incorrect, the starter/generator will need to be removed from the vehicle and disassembled by a qualified technician.
- Possible causes:
- A grounded F1 or F2 terminal or a grounded field coil.
9. Put the red (+) probe on the DF terminal and the black (–) probe on the F1 terminal. The reading should be between 4.5 and 5.5 ohms.
- 9.1. If the reading is incorrect, the starter/generator will need to be removed from the vehicle and disassembled by a qualified technician.
- Possible causes:
- A grounded DF terminal or a grounded field coil.
10. Make sure that wires are connected correctly and are tight. If they are not, rewire or tighten as necessary.

## TEST PROCEDURE 13 – Voltage Regulator

See General Warnings on page 1-1.

**NOTE:** This is a voltage test. Keep the battery connected while performing this test procedure.

1. If necessary, see Testing Basics.
2. Disable the vehicle.
3. Set the Maintenance/Operate switch to MAINTENANCE.
4. Make sure that the wires are connected correctly and are tight. If they are not, rewire or tighten as necessary.
5. Check the engine RPM setting to make sure that it is adjusted correctly.
6. Make sure that the battery is good and fully charged.
7. Turn the key switch to ON.
8. Operate the engine for several minutes to bring the voltage regulator to operating temperature.
9. Turn the key switch to OFF position.
10. Make sure that the red wire from the voltage regulator (1) is connected to the solenoid (2).

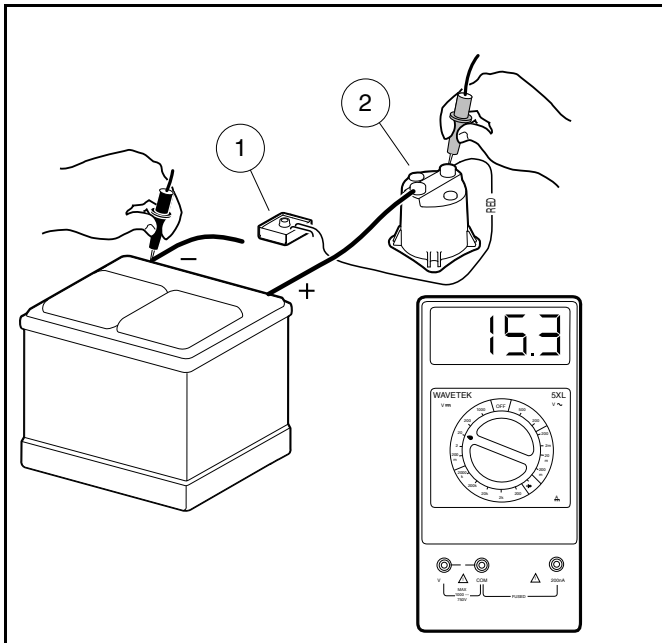

**Figure 11-14 Voltage Regulator Test**

11. Set the multimeter to 20 VDC.
12. Put the red (+) probe on the large post of the solenoid.
13. Put the black (-) probe on the negative (-) battery post.
14. Turn the key switch to the ON position.
15. Press the accelerator to start the engine and run it at full governed speed.
  - 15.1. If the reading is between 14.7 and 15.3 volts, the voltage regulator is good.
  - 15.2. If the reading is over 15.3 volts and continues to rise, replace the voltage regulator.
  - 15.3. If the reading is lower than 14.7 volts but rising steadily, check the battery condition.
  - 15.4. If the reading is lower than 14.7 volts and not rising, check the starter/generator. Go to the next step.

- 15.4.1. If the starter/generator is good, replace the voltage regulator.

## TEST PROCEDURE 14 – Ignition Spark

See General Warnings on page 1-1.

**NOTE:** Keep the battery connected while performing this test procedure.

Use an spark gap test tool (Thexton 404® or equivalent)

1. If necessary, see Testing Basics.
2. Disable the vehicle.
3. Set the Maintenance/Operate switch to MAINTENANCE.
4. Remove the spark plug wire (1) from the spark plug (2) (Figure 11-15, Page 11-26).

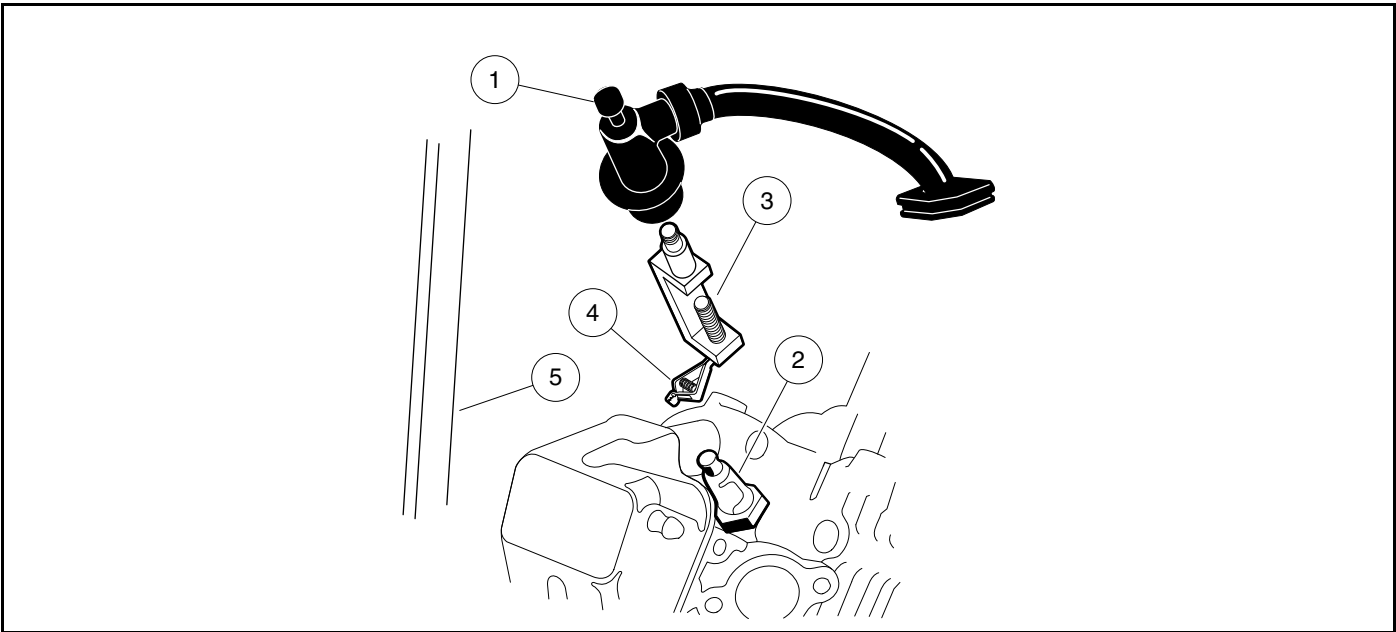

464B

**Figure 11-15 Ignition Spark Test**

5. Adjust the spark gap test tool (3) probes to approximately 18,000 volts (18 kV) setting (SE – *Small Engine Setting* on the Thexton 404® tool).
6. Connect the ignition spark gap test tool to the spark plug wire.
7. Connect the alligator clip (4) to a solid engine ground (5).
8. Start the engine.
  - 8.1. If the spark gap test tool has no spark, test the ignition circuit.
  - 8.2. If the spark gap test tool has a faint yellow or red color, test the ignition circuit.
  - 8.3. If the spark gap test tool has a strong blue spark, check the spark plug gap.
    - 8.3.1. If the spark plug gap is correct, replace the spark plug.

## TEST PROCEDURE 15 – Reverse Buzzer and Reverse Buzzer Limit Switch

See General Warnings on page 1-1.

**NOTE: Reverse Buzzer:** *This is a voltage test.*

A reverse buzzer is mounted on the back side of the instrument panel. On some models, another reverse buzzer is also mounted on a bracket at the left rear of the vehicle. The reverse buzzer is powered by the 10-amp ATM fuse.

1. If necessary, see Testing Basics.
2. Remove the instrument panel.
3. Check for proper wiring and tight connections.
4. Turn the key switch to ON.
5. Check that battery voltage is present in the orange/white wire at reverse buzzer.
  - 5.1. If there is no battery voltage, check the 10-amp ATM fuse.
6. Set the Forward/Neutral/Reverse control (FNR) to R.
  - 6.1. If the reverse buzzer does not sound, check the reverse buzzer limit switch.
7. Turn the key switch to OFF.

**NOTE: Reverse Buzzer Limit Switch:** *This is a continuity test.*

The reverse buzzer limit switch is located on the Forward/Reverse shifter. Purple/white and orange wires are connected to it.

1. Disconnect the black/orange wire from the reverse buzzer.
2. Set the Forward/Neutral/Reverse control (FNR) to R. there should be continuity between the black/orange wire and ground.
3. Check for continuity between the black/orange wire and ground.
  - 3.1. If there is no continuity, replace the reverse buzzer limit switch.
  - 3.2. If there is continuity, go to the next step.
4. Set the Forward/Neutral/Reverse control (FNR) to F.
  - 4.1. If there is continuity, replace the reverse buzzer limit switch.
  - 4.2. If there is no continuity, replace the reverse buzzer..

## TEST PROCEDURE 16 – Malfunction Indicator Light (MIL)

See General Warnings on page 1-1.

**NOTE:** This is a voltage test.

1. If necessary, see Testing Basics.
2. Remove the instrument panel.
3. Make sure that the wires are connected correctly and are tight. If they are not, rewire or tighten as necessary.
4. Turn the key switch to ON.
5. Check for battery voltage at red/green wire to malfunction indicator light (MIL).
  - 5.1. If there is no voltage, check the key switch.
  - 5.2. If there is battery voltage, use a test lead to ground the tan wire terminal of the MIL.
    - 5.2.1. If the light illuminates, the MIL is good.
    - 5.2.2. If the light does not illuminate, replace the MIL.

## TEST PROCEDURE 17 – Low Oil Warning Light (LED)

See General Warnings on page 1-1.

**NOTE:** This is a voltage test.

1. If necessary, see Testing Basics.
2. Remove the instrument panel.
3. Make sure that the wires are connected correctly and are tight. If they are not, rewire or tighten as necessary.
4. Turn the key switch to ON.
5. Check for battery voltage at yellow wire to low oil warning light.
  - 5.1. If there is no voltage, check the key switch.
  - 5.2. If there is battery voltage, use a test lead to ground the black wire terminal of the low oil warning light.
    - 5.2.1. If the light illuminates, the low oil warning light is good.
    - 5.2.2. If the light does not illuminate, replace the low oil warning light.

## TEST PROCEDURE 18 – Battery Test (Under Load)

See General Warnings on page 1-1.

**NOTE:** Keep the battery connected while performing this test procedure.

*The voltage reading listed is for electrolyte at 70 °F (21 °C). At lower electrolyte temperatures the voltage reading will be lower.*

1. If necessary, see Testing Basics.
2. Set the Forward/Neutral/Reverse control (FNR) to N.
3. Set the Maintenance/Operate switch to MAINTENANCE.
4. Put chocks against the wheels.
5. Set a multimeter to 20 VDC.
6. Put the red (+) probe on the F2 (white wire) terminal on the starter/generator (**Figure 11-16**).



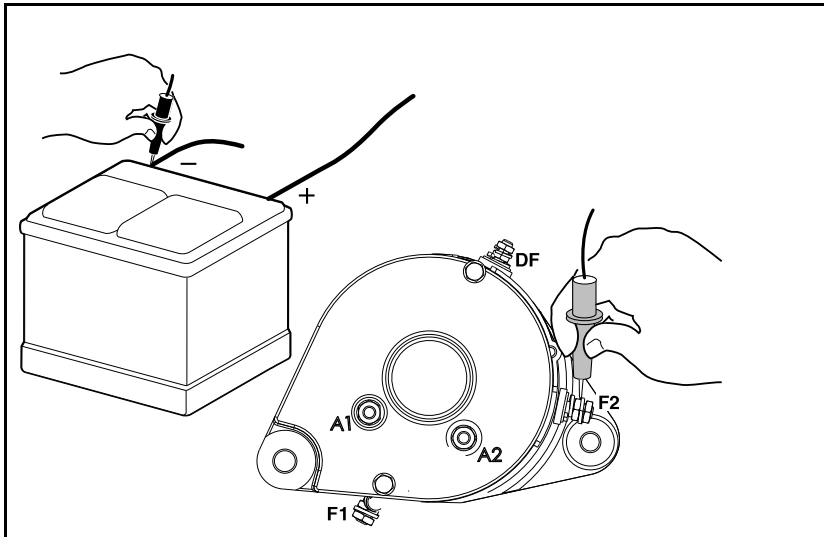

3030C

**Figure 11-16 Battery Test (Under Load)**

7. Put the black (-) probe on the negative (-) battery post.
8. Turn the key switch to ON.
9. Make sure that the FNR is in N, and push the accelerator pedal.

**NOTE:** With the accelerator pedal pushed, the battery is under load.

- 9.1. If the voltage reading is over 9.6 volts, with an electrolyte temperature of 70 °F (21 °C), check the starter/generator.
  - 9.2. If the reading is below 9.6 volts, with an electrolyte temperature of 70 °F (21 °C), check the battery.
  - 9.3. If the reading is zero, there may be no continuity across the large posts of the solenoid. Check the solenoid.
  - 9.4. If all of the test results are good and the voltage reading is zero, there may be a broken or damaged 6-gauge white wire from the solenoid to the starter/generator.
10. If all of the test results are good and the voltage reading is zero, there may be a broken or damaged 6-gauge white wire from the solenoid to the starter/generator.

**TEST PROCEDURE 19 – Fuel Pump**

See General Warnings on page 1-1.

**⚠ WARNING**

- To avoid the possibility of fire or explosion, make sure the fuel tank cap is securely in place while performing this test procedure.

**NOTE:** This is a voltage and resistance test.

**Voltage to Fuel Pump**

1. If necessary, see Testing Basics.
2. Check the 10 amp fuse in the fuel pump circuit.
  - 2.1. If the 10 amp fuse is bad, replace the fuse.
  - 2.2. If the 10 amp fuse is good, go to the next step.
3. Disconnect the fuel pump connector from the top of the fuel pump module.
4. Set the Maintenance/Operate switch to MAINTENANCE.
5. Put chocks against the wheels.
6. While the engine is running, check for battery voltage between ground and the pin 5 of the fuel pump connector.

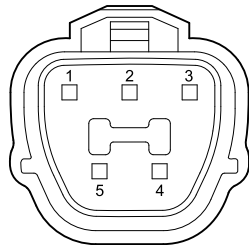

Pin	Wire Color	Description
1	Open	Open
2	Orange/Black	Sending Unit Positive (+)
3	Black	Sending Unit Negative (-)
4	Black/White	Fuel Pump Negative (-)
5	Red/White	Fuel Pump Positive (+)

**Figure 11-17 Fuel Pump Connector**

- 6.1. If there is no voltage, check for battery voltage at the red wire of the fuel pump relay while the engine is running.
  - 6.1.1. If there is battery voltage, replace the fuel pump relay.
  - 6.1.2. If there is no battery voltage, check the key switch.
- 6.2. If there is voltage, check for battery voltage at the black/white wire of the fuel pump relay while the engine is running.
  - 6.2.1. If there is no voltage, replace the fuel pump relay.

6.2.2. If there is voltage, check the fuel pump resistance.

**Fuel Pump Resistance Procedure**

1. If necessary, see Testing Basics.
2. Disconnect the battery.
3. Disconnect the fuel pump connector from the top of the fuel pump module.
4. Set the multimeter to 200 Ohms.
5. Check for approximately 2 to 5 ohms between pin (1) and pin (2) terminals in fuel pump module.

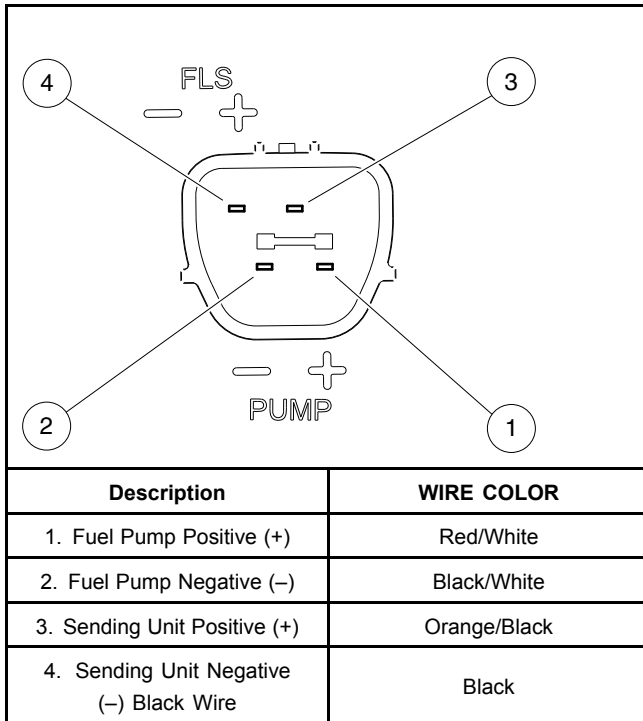

3031

**Figure 11-18 Fuel Pump Module Terminals**

- 5.1. If the reading indicates no resistance, the fuel pump has failed and the fuel pump module must be replaced.
- 5.2. If the reading is correct and the fuel pump does not function correctly, go to the next steps. Leave the battery disconnected while checking continuity.
  - 5.2.1. Check the continuity from the black/white wire of the fuel pump relay to pin (G) of the ECU connector.

**ECU Connector**

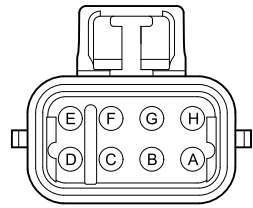

Pin	Wire Color	Description
A	Red	Switched 12V Power
B	Red	Constant 12V Power
C	Open	NA
D	Tan	Malfunction Indicator Light (MIL)
E	White	Ground Kill Wire
F	Green	Low Oil Light
G	Black / White	Fuel Pump
H	Open	NA

Figure 11-19 ECU Connector

## TEST PROCEDURE 20 – Fuel Level Sending Unit

See General Warnings on page 1-1.

### **⚠ WARNING**

- To avoid the possibility of fire or explosion, make sure the fuel tank cap is securely in place while performing this test procedure.

**NOTE:** This is a resistance test.

1. If necessary, see Testing Basics.
2. Disconnect the battery.
3. Disconnect the fuel pump connector from the top of the fuel pump module.
4. Check the resistance between pin (3) and pin (4) terminals in module.

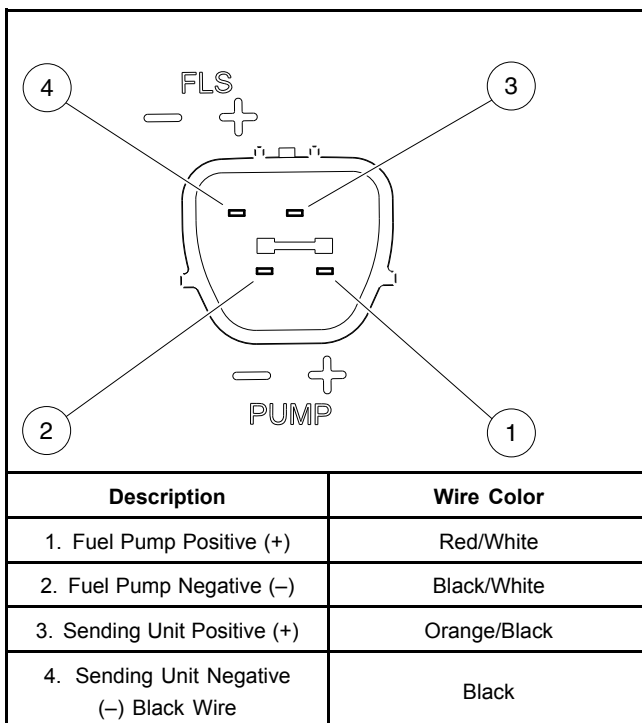

3031

**Figure 11-20 Fuel Pump Module Terminals**

5. The following resistance readings (in ohms) should be obtained depending on the position of the float inside the fuel tank. The resistance reading will vary according to the exact position of the float. The chart below may be used as a guideline to determine if the fuel level sending unit is operating correctly. Make sure the float is at the surface of the fuel in the tank.

FLOAT POSITION	RESISTANCE READING	FUEL GAUGE READINGS
Lower position (tank empty)	250 ohms ( $\pm 10$ )	Empty
Center position (tank half full)	141 ohms ( $\pm 8$ )	Half full
Upper position (tank full)	33.3 ohms ( $\pm 6$ )	Full

- 5.1. If the readings are within the specifications listed above, the fuel level sending unit is working properly.
- 5.2. If the readings are incorrect, the fuel level sending unit has failed and the fuel pump module must be replaced.
- 5.3. If the readings are correct and the fuel gauge does not function correctly, go to the next steps. Leave the battery disconnected while checking continuity.
  - 5.3.1. Check the continuity of the orange/black wire from the fuel level sending unit to the purple wire on the fuel gauge/hour meter.
  - 5.3.2. Check the continuity of the red/white wire from the fuel gauge/hour meter to the brown/white wire on the key switch.
  - 5.3.3. Check the continuity of the black ground wire at the fuel level sending unit.
  - 5.3.4. Check the continuity of the black ground wires at the fuel gauge/hour meter.
6. If the readings are correct according to the position of the float, but give an incorrect reading on the fuel gauge/hour meter, test the fuel gauge/hour meter.

## TEST PROCEDURE 21 – Fuel Gauge

See General Warnings on page 1-1.

**NOTE:** This is a voltage test.

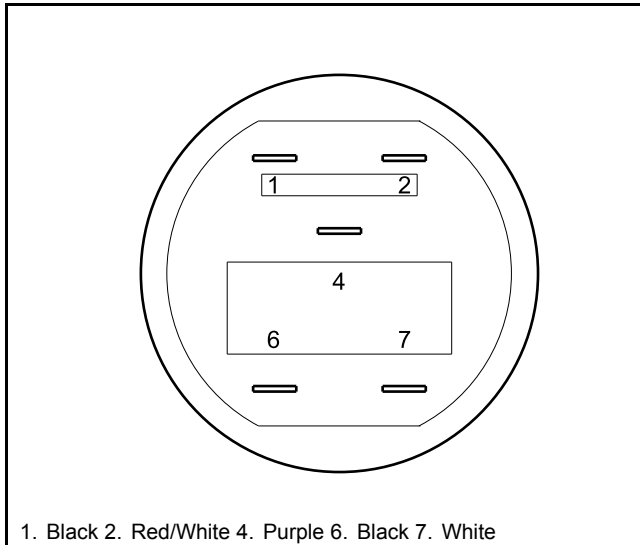

480

**Figure 11-21 Fuel Gauge/Hour Meter**

1. If necessary, see Testing Basics.
2. Disable the vehicle.
3. Remove the instrument panel to gain access to the back of the fuel gauge/hour meter.
4. Place a sheet of insulating material between the front frame and the electrical connections on the rear of the instrument panel to prevent contact between the two.
5. Disconnect the purple wire (1) from the fuel gauge/hour meter (**Figure 11-22, Page 11-35**).

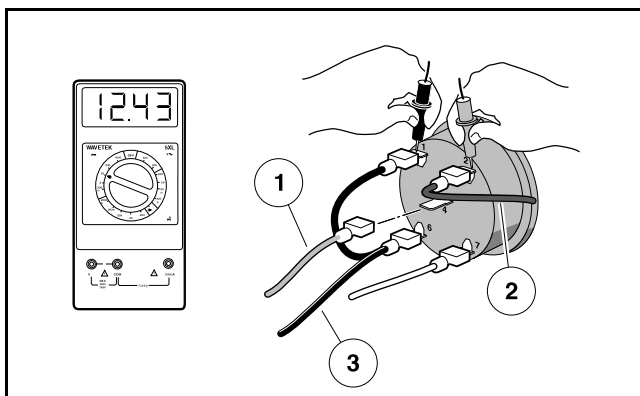

481B

**Figure 11-22 Fuel Gauge Voltage Test - Terminal 2**

6. Set a multimeter to 20 VDC.
7. Put the red (+) probe of the multimeter on the positive post of the battery.
8. Put the black (-) probe on the negative post of the battery. Record the voltage reading.
9. Put the red (+) probe on terminal 2 of the fuel gauge/hour meter with the red/white wire (2) connected.

10. Put the black (-) probe on terminal 1 of the fuel gauge/hour meter with the black wire (3) connected.
11. Turn the key switch ON. The voltage reading should be the same as the battery voltage reading recorded earlier.
  - 11.1. If not, check the continuity of the red/white and black wires.
12. Make sure that the purple wire (1) is disconnected (**Figure 11-23, Page 11-36**).

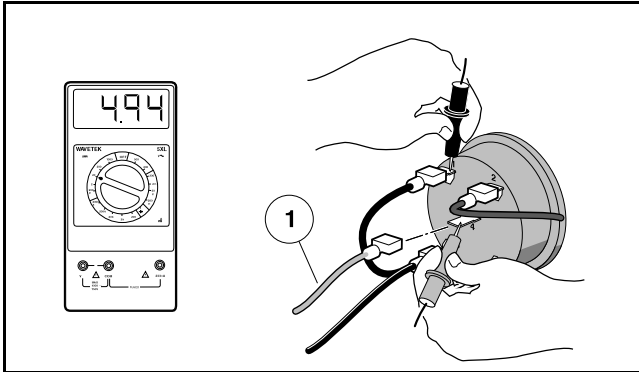

482B

**Figure 11-23 Fuel Gauge Voltage Test - Terminal 4**

13. Put the black (-) probe on terminal 1 of the fuel gauge/hour meter.
14. Put the red (+) probe on terminal 4 of the fuel gauge/hour meter. The voltage reading should be approximately 4.94 volts.
  - 14.1. If the reading is incorrect, replace the fuel gauge/hour meter.

## TEST PROCEDURE 22 – Hour Meter

See General Warnings on page 1-1.

### **⚠ DANGER**

- Do not operate vehicle in an enclosed area without proper ventilation. The engine produces carbon monoxide, which is an odorless, deadly poison.

**NOTE:** Keep the battery connected while performing this test procedure.

1. If necessary, see Testing Basics.
2. Disable the vehicle.
3. Make sure that the key switch OFF.
4. Check the hour meter display. It is powered by an internal battery and should always be on, even with the engine off and the key removed.
5. Start the engine and let it idle.
6. With engine idling, the "hour glass" icon should flash.
  - 6.1. If not, check the low oil warning light and the oil pressure switch. **See following NOTE.**

**NOTE:** The hour meter is designed to record actual engine running time and will not start adding increments until the engine is running and the oil pressure switch has opened.

7. If the hour meter still does not function after the low oil warning light, oil pressure switch, and all of the appropriate wires have been checked for continuity, replace the fuel gauge/hour meter.



## TEST PROCEDURE 23 – Headlight Switch

See General Warnings on page 1-1.

**NOTE:** The headlight circuit is protected by the 20-amp fuse. Check the fuse before this procedure is performed.  
See Test Procedure 2 – Fuses on page 11-10.

*This is a voltage test.*

1. If necessary, see Testing Basics.
2. Check the 20 amp fuse that protects the headlight circuit.
  - 2.1. If the fuse is bad, replace the fuse.
  - 2.2. If the fuse is good, go to the next step.
3. Remove the instrument panel.
4. Set the multimeter set to 20 VDC.
5. Put alligator clips on the multimeter probes.
6. Connect the red (+) probe to terminal of the headlight switch where the green/white wire is connected..
7. Connect the black (–) probe of the multimeter to ground.
8. Set the headlight switch to OFF.
  - 8.1. If there is voltage, replace the headlight switch.
  - 8.2. If there is no voltage, go to the next step.
9. Set the headlight switch to ON.
  - 9.1. If there is battery voltage, the headlight switch is good.
  - 9.2. If there is no voltage, check the associated wiring and 10 amp fuse.
    - 9.2.1. If the wires and fuse show continuity and the readings are still incorrect, replace the headlight switch.

## TEST PROCEDURE 24 – Voltage at Headlight Socket

See General Warnings on page 1-1.

**NOTE:** This is a voltage test.

1. If necessary, see Test Basics.
2. Inspect the wires at the light bulb socket. Make sure the wires are securely fastened to the contacts inside the socket and that wires are installed correctly.
3. Remove the wire harness connector from the headlight bulb.
4. Set the headlight switch to ON.
5. Check for voltage across the two terminals in the connector.

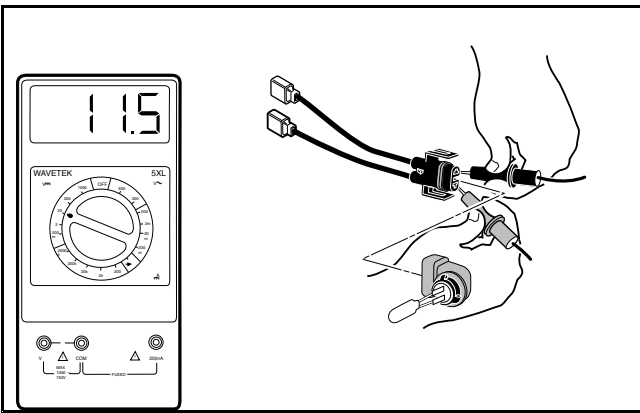

485

**Figure 11-24 Voltage Measurement at Headlight Socket**

- 5.1. If there is battery voltage, check and replace the headlight bulb as necessary..
- 5.2. If there is no voltage, check the associated wiring, light switch, and 10-amp fuse.

## TEST PROCEDURE 25 – Voltage Limiter

See General Warnings on page 1-1.

**NOTE:** This is a diode test.

The voltage limiter is a diode. Diodes are designed to conduct current in one direction only. **See following NOTE.**

**NOTE:** If the voltage limiter conducts current in both directions, the diode has failed closed. If the voltage limiter will not conduct current in either direction, the diode has failed open.

1. If necessary, see Testing Basics.
2. Disable the vehicle.
3. Remove the cowl.
4. Disconnect the black wire from positive (+) terminal of voltage limiter.
5. Disconnect the green wire from negative (-) terminal of the voltage limiter.
6. Set the multimeter to the diode setting.

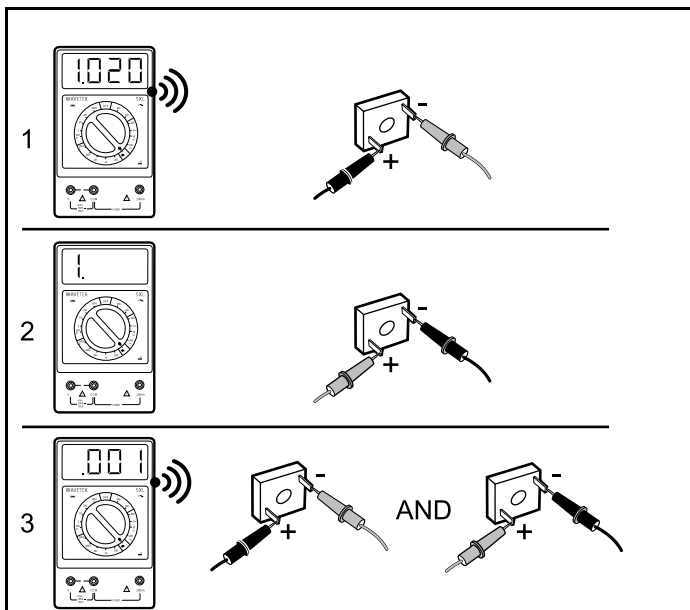

**Figure 11-25 Voltage Limiter Test**

7. Put the red (+) probe on the negative (-) diode terminal.
8. Put the black (-) probe on the positive (+) diode terminal.
- 8.1. Check for continuity (1). Go to the next step.
9. Put the red (+) probe on the positive (+) diode terminal.
10. Put the black (-) probe on the negative (-) diode terminal.
- 10.1. If there is no continuity (2), the diode is good.
- 10.2. If there is continuity (3), replace the diode.

**TEST PROCEDURE 26 – 4-Pin Connector (for Connected Car Device)**

See General Warnings on page 1-1.

**NOTE:** This is a voltage and continuity test.

The Connected Car Device 4-pin connector is used for Guardian/Visage and is labeled “V3 circuit” on the main wire harness.

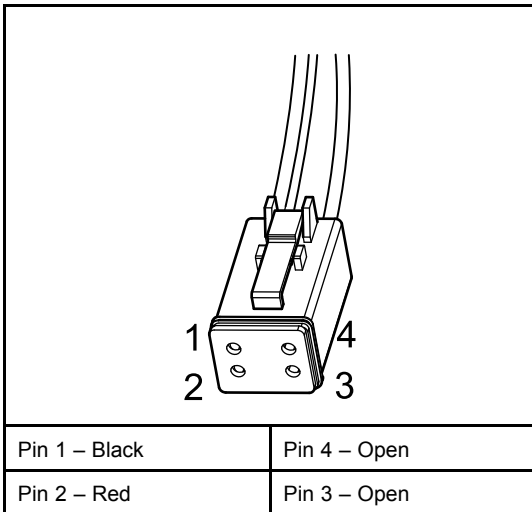

2786

**Figure 11-26 4-Pin Connector**

1. If necessary, see Testing Basics.
2. Set the multimeter to 200 Ohms.
3. Check for continuity between pin 1 (black wire) of the 4-pin connector (**Figure 11-26, Page 11-40**) and pin 18 (black wire) of the black 18-pin connector on the ECU.
  - 3.1. If there is continuity, go to the next step.
  - 3.2. If there is no continuity, check sonic welds 4, 10, and 14. Proceed to the next step.
4. Set the key switch to ON.
5. Set the multimeter to 20 VDC.
6. Check for battery voltage at pin 2 (red wire) of the 4-pin connector.
  - 6.1. If there is battery voltage, go to the next step.
  - 6.2. If there is no voltage, check the 2-amp fuse located near the 4-pin connector. **See following NOTE.**

**NOTE:** The red wire only has battery voltage with the key switch in the ON position.

- 6.3. If the 2-amp fuse is good, check the 5-amp fuse located near the electrical box.
7. Set the key switch to ON.
8. Set the multimeter to 20 VDC.
9. Check the voltage at pin 4 (blue wire) of the 4-pin connector. **See following NOTE.**

**NOTE:** The blue wire only has voltage with the key switch in the ON position.

- 9.1. If the voltage is approximately 11.8 volts, the 4-pin connector circuit is good.

9.2. If the voltage is incorrect, check the wiring and then the ECU. **See following NOTE.**

**NOTE:** *If pin 4 has no voltage, the ECU LIN (Local Interconnect bus) may have failed. If the vehicle does not use Guardian or Visage, the vehicle can be driven and will not show any symptoms. If a vehicle uses Guardian or Visage, Guardian or Visage will disable the vehicle until communication is restored.*

Pagination Page

## **⚠ DANGER**

- See General Warnings on page 1-1.

## **⚠ WARNING**

- See General Warnings on page 1-1.

## GENERAL INFORMATION

### **⚠ WARNING**

- To prevent damage to the ECU, never mix the black and gray connectors that attach to it. The black connector is tethered to the ECU mounting plate to help prevent accidentally installing it in the gray port.

This section covers the electrical components for the gasoline vehicle.

## STARTER/GENERATOR

### STARTER/GENERATOR REMOVAL

1. Disconnect the battery and spark plug wire.
2. Set the Maintenance/Operate switch to MAINTENANCE.
3. Disconnect the wires from the starter/generator (**Figure 12-1**).

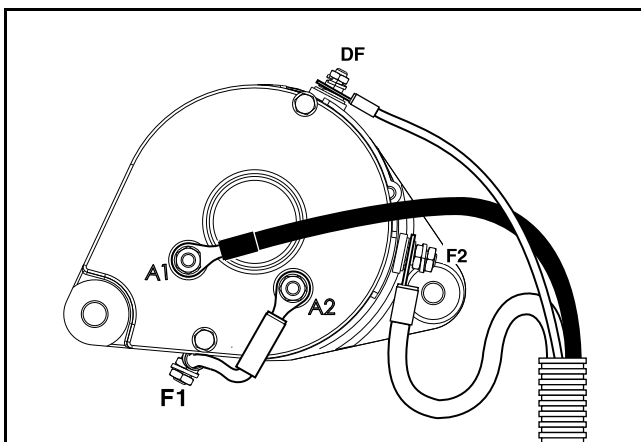

3033C

**Figure 12-1 Starter/Generator Wiring**

4. Loosen the pivot nuts (1) and pivot bolts (2) (**Figure 12-2, Page 12-2**).

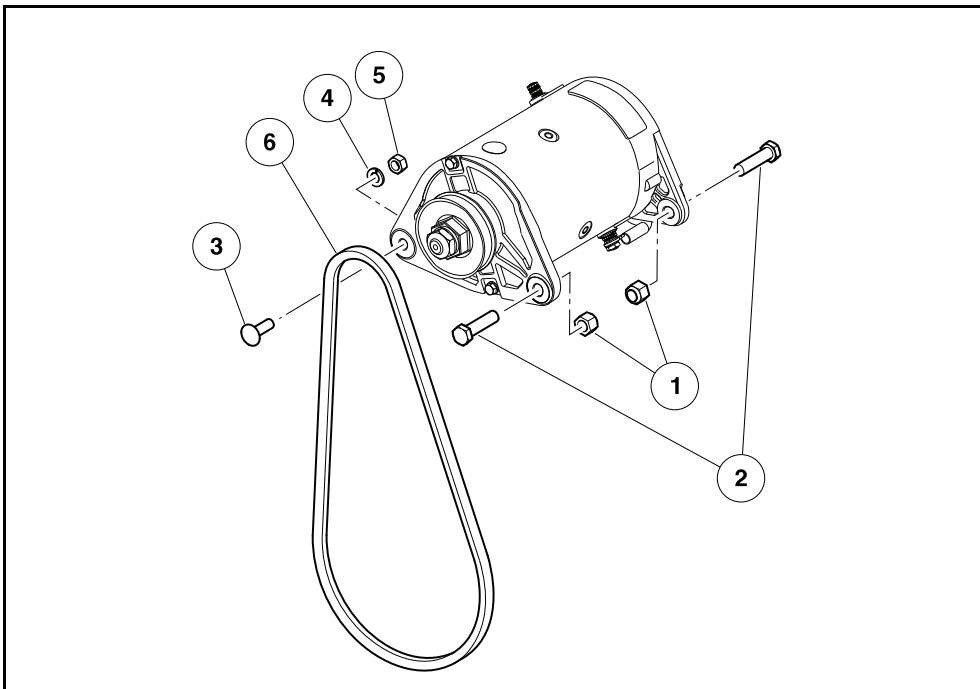

2997B

**Figure 12-2 Starter/Generator Removal**

5. Remove the adjustment nut (3), washer (4) and adjustment bolt (5).
6. Lower the starter/generator and remove the belt (6) from the pulley.
7. Support the starter/generator so that when the pivot bolts are removed the starter/generator will not fall.
8. Remove the pivot nuts and bolts from the mounting bracket.
9. Remove the starter/generator.

## DISASSEMBLY OF THE STARTER/GENERATOR TO SERVICE THE BRUSHES

1. Remove the two bolts (20) and pull commutator end cover (23) free of starter/generator housing (24) (**Figure 12-3, Page 12-3**). See following NOTE.

**NOTE:** If the brushes are not removed, contact between the brushes and commutator as the commutator end cover is being removed or installed could damage the brushes. Lift the brush springs out of the notches in the brushes and pull the brushes back from the center of the commutator end cover. The springs will rest on the sides of the brushes and help prevent them from sliding towards the center of the cover (**Figure 12-7, Page 12-5**).

2. Remove brush covers (29 and 30), terminal hardware (25), brush springs (28), and brushes (27) (**Figure 12-4, Page 12-3**). See following NOTE.

**NOTE:** To clean and inspect the armature/commutator and the bearings, see **Disassembly of the Starter/Generator to Service the Armature/Commutator on page 12-5**.



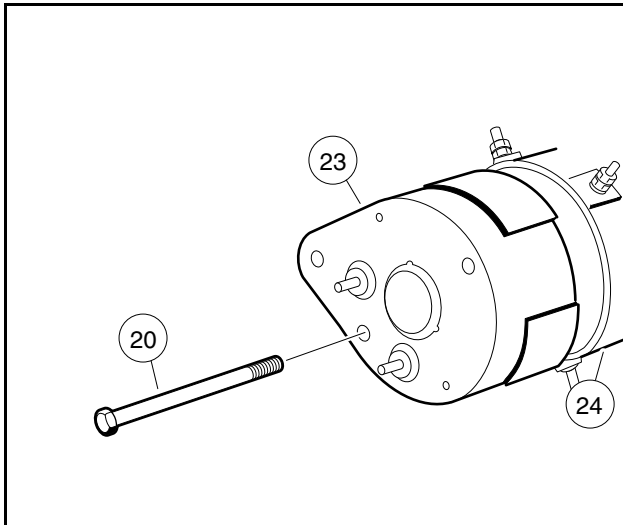

487

Figure 12-3 Commutator End Cover

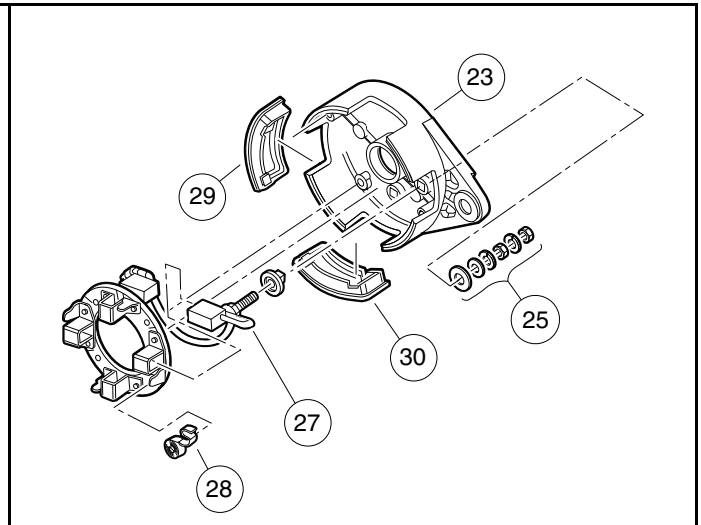

Figure 12-4 Brush Covers and Brushes

## BRUSH INSPECTION AND REPLACEMENT

1. Visually inspect brushes. Replace brushes that are cracked or severely chipped.
2. Measure the length of each brush. Replace the brush set if a brush is less than 0.375 inch (9.5 mm) (**Figure 12-5, Page 12-3**).

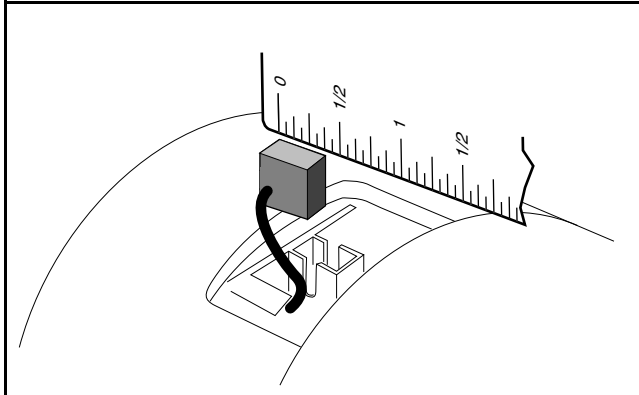

Figure 12-5 Inspect Brushes and Measure Length

## BRUSH SPRING INSPECTION AND REPLACEMENT

1. Visually inspect springs. Replace all four springs if any spring is discolored from heat (straw or bluish in color).
2. Install the four brushes (27) into their holders and insert the four brush springs (28) (**Figure 12-4, Page 12-3**). Using a spring scale, test brush spring tension. If any spring has a tension less than 24 ozf (0.68 kgf), replace all four springs (**Figure 12-6, Page 12-4**). **See following CAUTION.**

**⚠ CAUTION**

- When checking brush spring tension, do not push springs beyond the point they would normally be if there were new brushes installed. Exerting excessive force or pushing brush springs beyond their normal maximum extension point will damage springs.

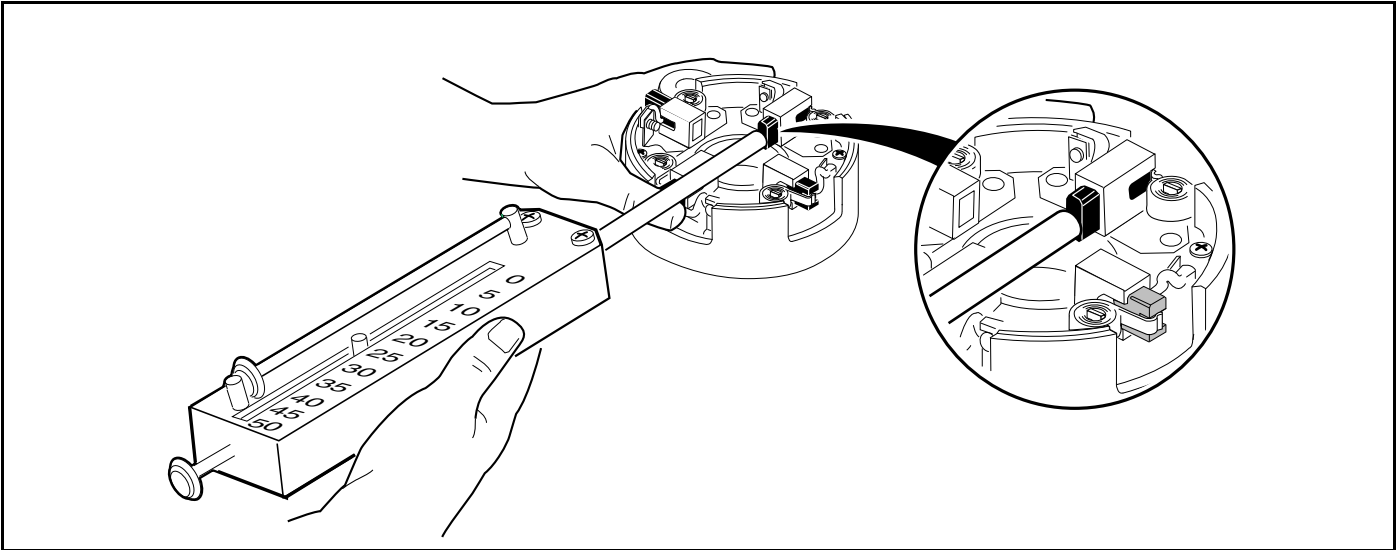

490

Figure 12-6 Brush Spring Tension Test

**STARTER/GENERATOR ASSEMBLY**

1. Install the brushes (27) into the holders. Install the terminal hardware (25) (**Figure 12-4, Page 12-3**).
2. To prevent contact between the brushes and commutator as the commutator is installed, and possible damage to the brushes, lift the brush springs and pull the brushes back from the center of the commutator end cover. The springs will rest on the sides of the brushes and help prevent them from sliding towards the center of the cover (**Figure 12-7, Page 12-5**).
3. Install the commutator end cover (23) onto the armature shaft. Align the locating pin with the pin hole in the cover. Install two M6 x 180 mm bolts (20) and tighten to 100 in·lb (11.3 N·m) (**Figure 12-3, Page 12-3**).
4. Push the brushes down into the holders. Position springs on the end of the brushes. Install the brush cover (30) that has the drain hole in it next to the A2 terminal. Install the remaining three brush covers (29) in the openings in the commutator end cover (23) (**Figure 12-4, Page 12-3**).

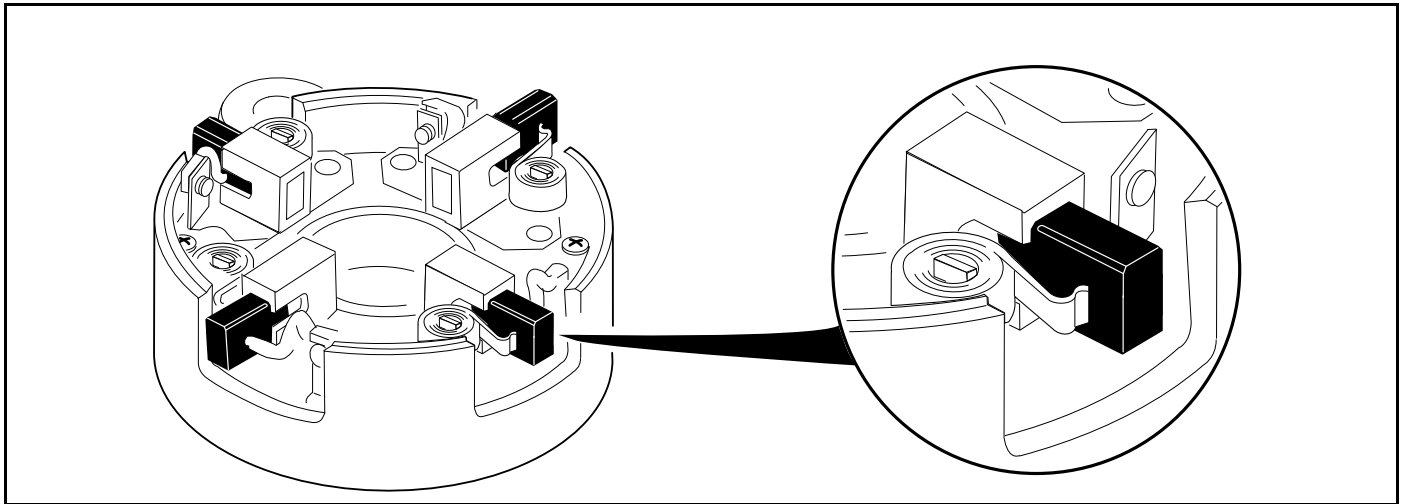
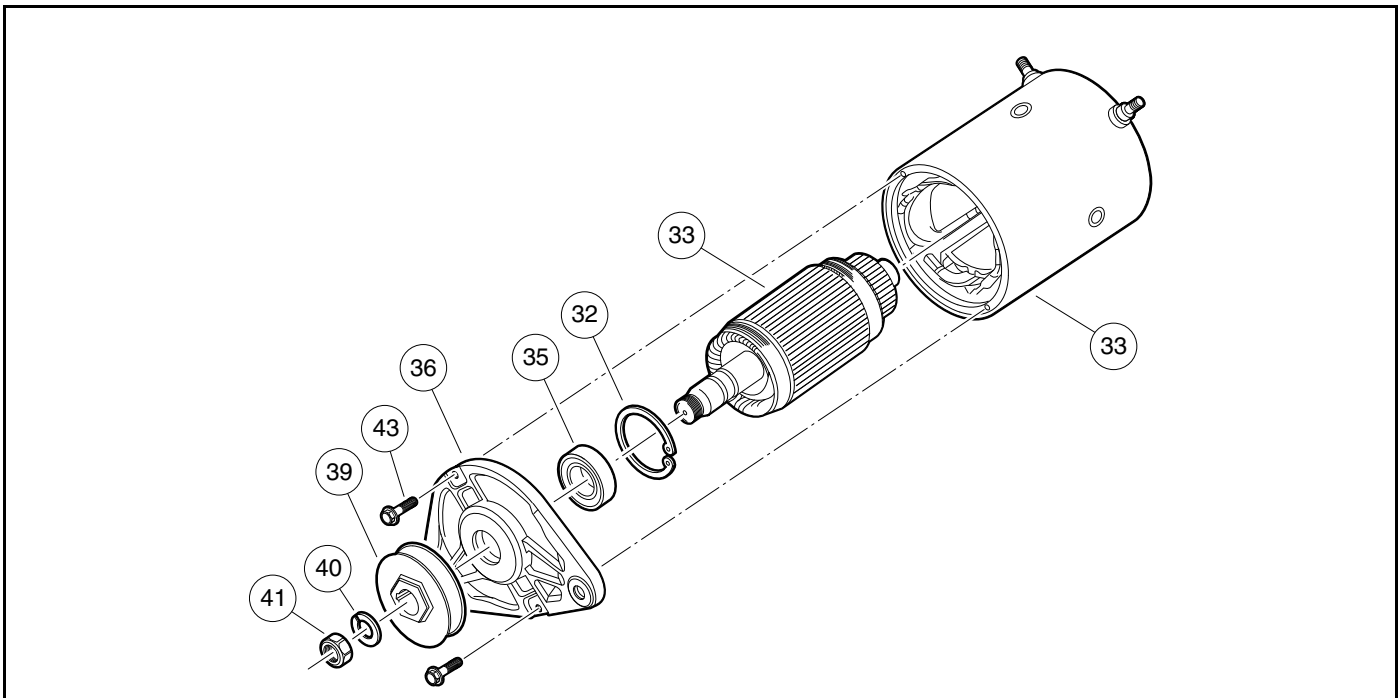

Figure 12-7 Pull Brushes Away From Center of the Commutator End Cover

### DISASSEMBLY OF THE STARTER/GENERATOR TO SERVICE THE ARMATURE/COMMUTATOR

1. Remove the commutator end cover to prevent damage to the brushes and armature.
2. To separate armature and output end cover assembly from the field coil housing, first remove the two securing bolts (43). Carefully remove armature and output end cover assembly from the field coil housing so components are not damaged.
3. To separate armature (33) from output end cover (36), remove nut (41), lock washer (40), pulley (39). It may be necessary to use the wedge attachment tool to remove the pulley from the shaft.
4. Remove the internal retaining ring (32) to release the bearing (35) and armature (33) from the output end cover (36). (**Figure 12-8, Page 12-6**).



1342

Figure 12-8 Output End Cover Assembly, Armature and Housing

## BEARING CLEANING AND INSPECTION

1. Using a clean cloth, wipe the carbon dust from the two bearings. Inspect bearings by spinning them by hand and checking for both axial (A) and radial (B) play (**Figure 12-9, Page 12-6**).
2. Replace the bearing if it is noisy, does not spin smoothly, or has excessive play. Check the bearings and replace if rusted, worn, cracked, or if there is an abnormal color change in the metal of the bearing. Bearings should be replaced if there is extensive wear or pitting on the balls or on the rolling surfaces. Do not remove the bearings unless they are to be replaced.

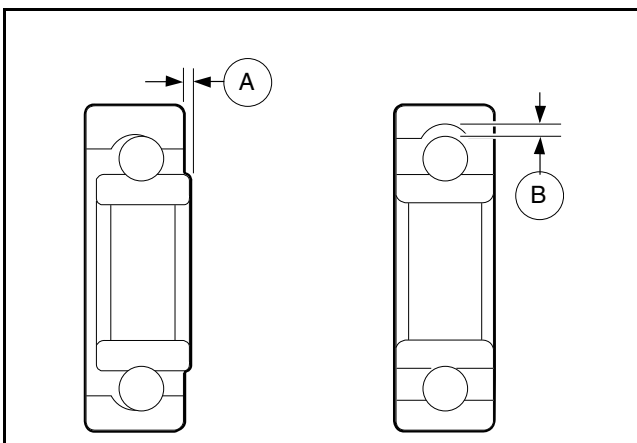

493

Figure 12-9 Bearing Play Inspection

## BEARING REMOVAL

1. Place the wedge attachment tool between the bearing and the armature. Make sure the wedge attachment tool is supporting the inner race of the bearing. If a press is not available, secure a bearing puller to the wedge attachment tool and pull the bearing off of the end of the armature shaft. Support the armature so that it will not drop when the bearing is removed (**Figure 12-10, Page 12-7**).
2. Slide the bearing retainer ring (32) off of the output end of the shaft (**Figure 12-8, Page 12-6**).

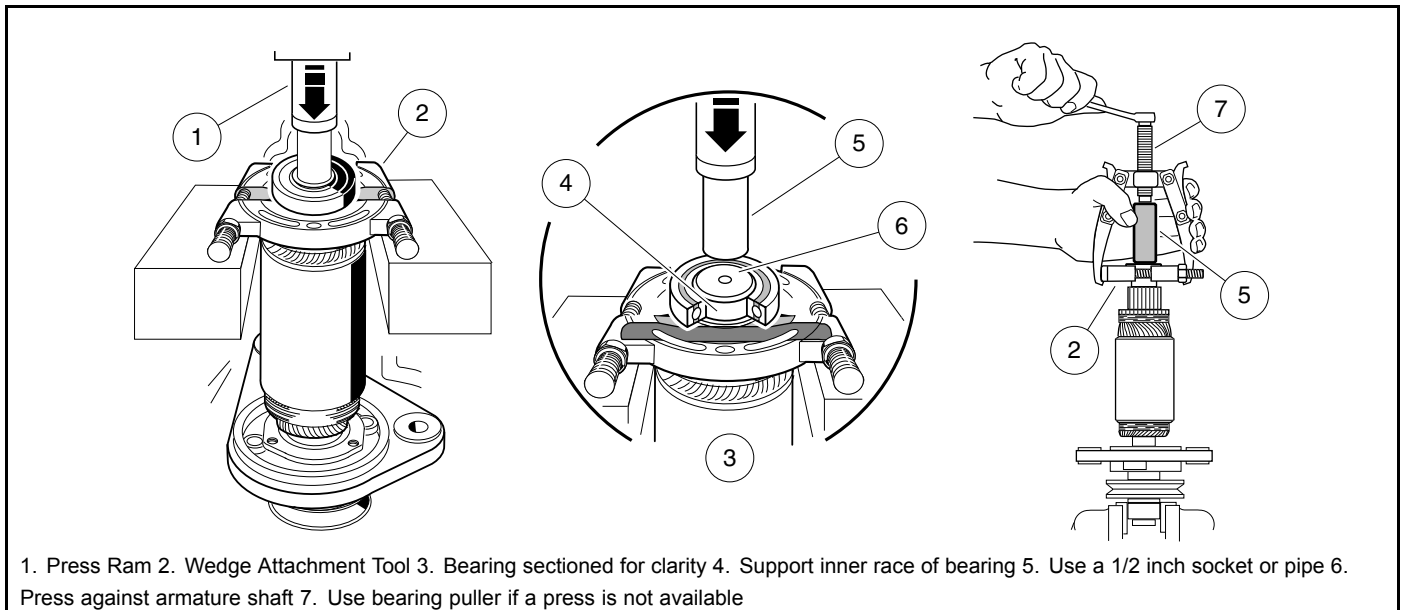

494

**Figure 12-10 Bearing Removal**

## FIELD COIL ASSEMBLY

Replace entire field coil housing assembly if coils, pole shoes or terminals are damaged. (**Figure 12-11, Page 12-8**).

## VISUAL INSPECTION OF ARMATURE

Obvious defects can be seen by examining the armature. If an armature has frayed or charred insulation, broken wires or thrown solder, it is obvious without testing that it should be replaced. Faults seen during the visual inspection can aid in diagnosing the original cause of the failure. Items to look for are listed below.

- Burned, charred, or cracked insulation
- Improperly cured varnish
- Thrown solder
- Flared armature windings
- Worn, burned, or glazed commutator
- Loose or raised commutator bars
- Bruised or damaged armature core laminations
- Worn armature bearing or shaft
- Dirty or oily commutator

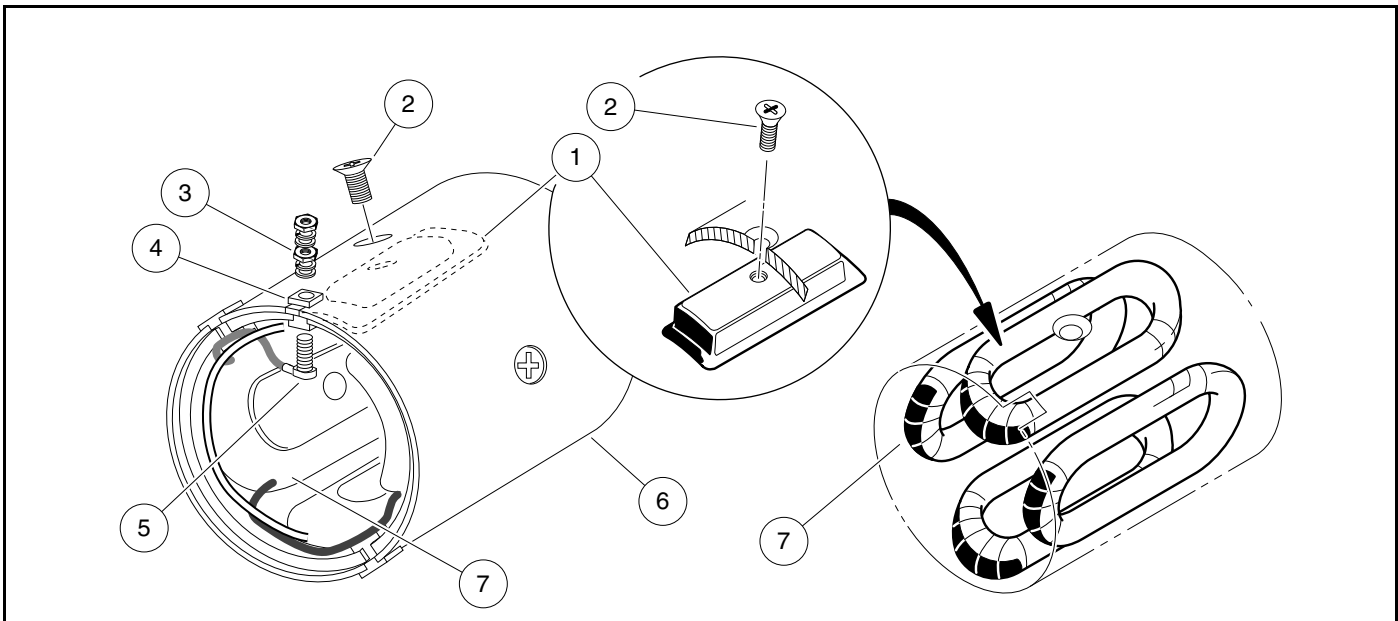

495

Figure 12-11 Field Coil Assembly

## COMMUTATOR CLEANING AND INSPECTION

1. Clean the carbon dust, dirt and oil from the commutator. Visually inspect the commutator for worn, burned or glazed areas. Check for loose or raised commutator bars. Slight roughness of the commutator can be polished away with 400 grit (or finer) sandpaper. **See following CAUTION.**

### **⚠ CAUTION**

- Do not use emery cloth on the commutator. Particles of emery are conductive and may short-circuit the commutator bars. Do not use oil or lubricants on the commutator or brushes.
2. Using a micrometer, measure the outside diameter at two points along the commutator. If the commutator outside diameter is less than 1.535 inches (39 mm), replace the armature and bearings (**Figure 12-12, Page 12-9**).

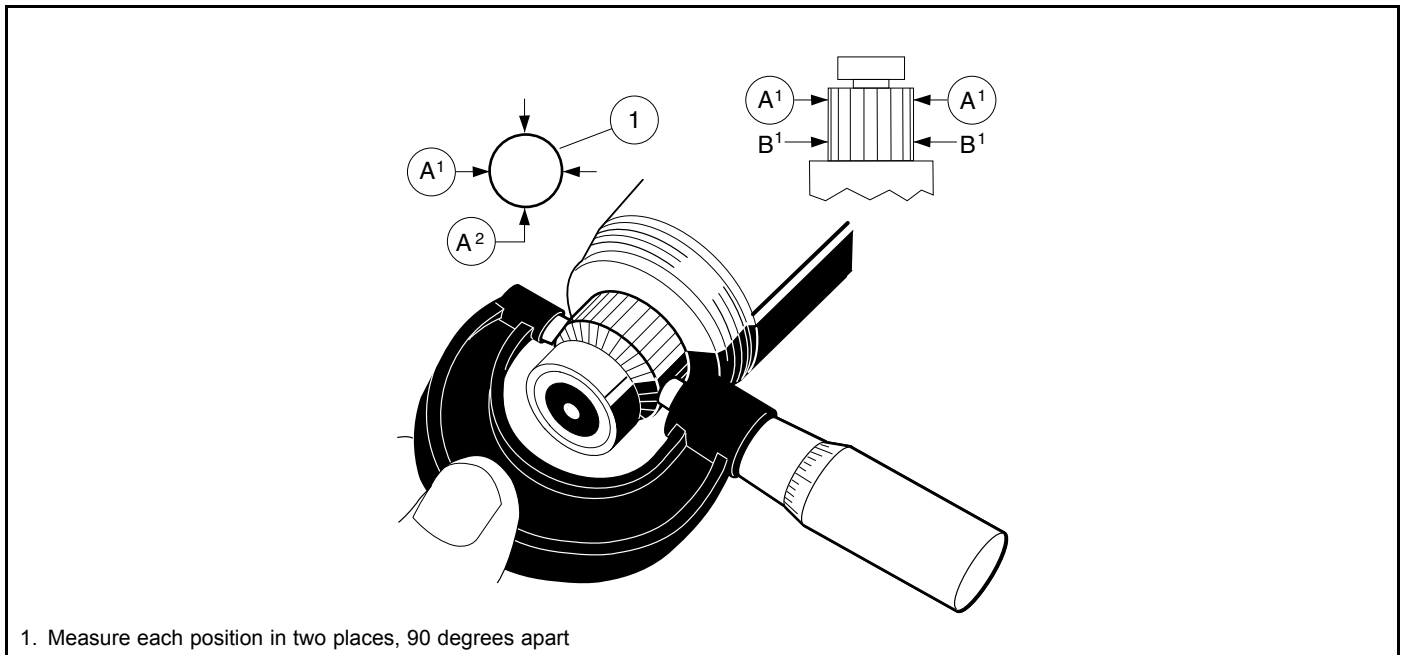

496

Figure 12-12 Inspect Commutator

## ARMATURE GROUND TEST

### **⚠ CAUTION**

- Do not submerge armature in solvent.

**NOTE:** Before testing, wipe the armature with a clean cloth and remove carbon dust and metal particles from between commutator bars.

Using a multimeter set on 200 ohms, place the positive (+) probe on the commutator bars and the negative (–) probe on the armature core. The reading should be no continuity. If the reading is incorrect, replace the armature and the two bearings (Figure 12-13, Page 12-10).

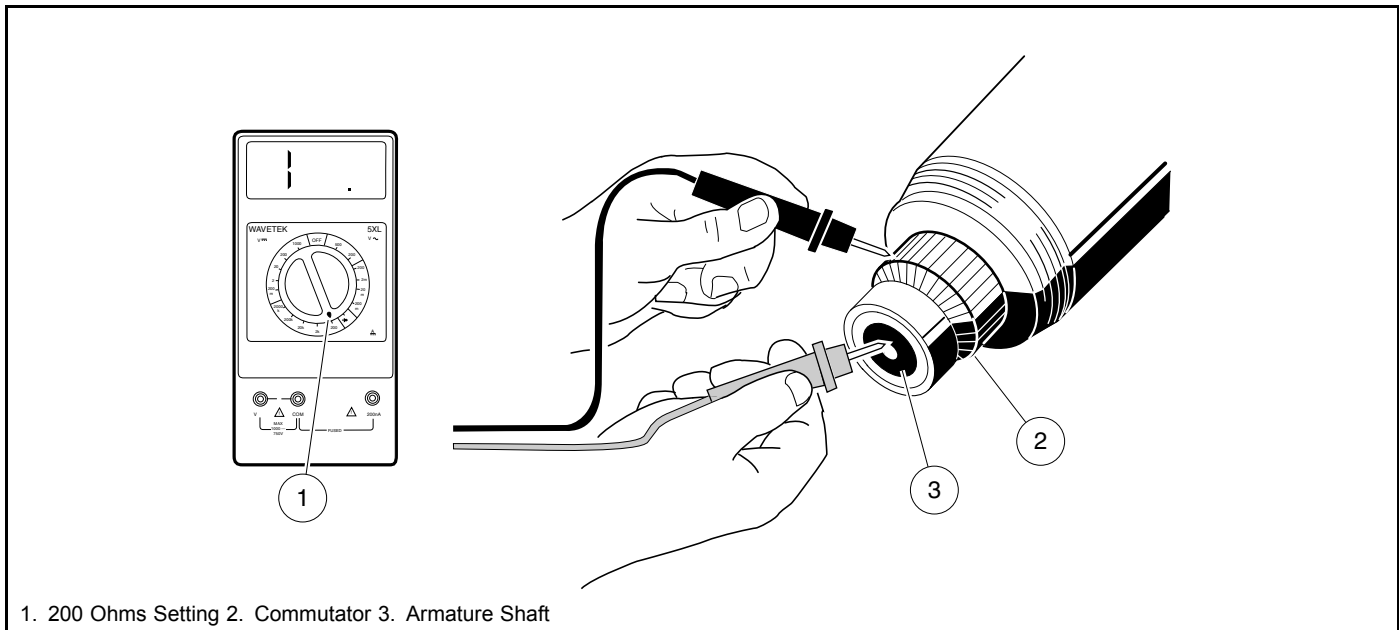

497

Figure 12-13 Armature Ground Test

## VISUAL INSPECTION OF FIELD COILS

If the insulation on the field coils appears blackened or charred, the serviceability of the coils is questionable. Burned or scorched coil insulation indicates the starter/generator has overheated due to overloads or grounded or shorted coil windings. Be sure the insulators are tight in the housing.

## STARTER/GENERATOR REWORK

Any rework must be performed by a qualified technician. Starter/generator service specifications are listed in the following table.

ITEM	SERVICE LIMIT
Commutator diameter (minimum)	1.60 in. (41 mm)
Concentric with armature shaft within	0.002 in. (0.051 mm)
Minimum commutator diameter for reslotting	1.65 in. (42 mm)
Undercut (Commutator must have a minimum diameter of 1.65 in (42 mm) for reslotting):	0.050 in. (1.3 mm)
Dielectric strength	500 VAC for one minute
Armature insulation resistance	0.2M (ohms) at 500 VDC
Starter field coil resistance	0.006 to 0.01 ohms
Generator field coil resistance	4.5 to 5.5 ohms

## STARTER/GENERATOR ASSEMBLY

- Slide the bearing retainer (32) onto the output end of the armature shaft (33) (Figure 12-8, Page 12-6).



2. Press a new ball bearing (35) onto the output end of the armature (**Figure 12-8, Page 12-6**). Press a new ball bearing onto the commutator end of the armature shaft. **See following CAUTION.**

### **⚠ CAUTION**

- To prevent damage to the retainer, use care while pressing new bearing onto the output end of the shaft.
- Press against the inner race of the new bearing until it is fully seated.

3. Install the drive end cover (36) onto the armature. Secure the bearing retainer ring (32) (**Figure 12-8, Page 12-6**).
4. Slide the housing with field coils over the armature. Use the tapped mounting holes to align housing to the cover, rotate and orient as shown.

**NOTE:** The terminal insulators should be on the commutator end of the housing.

5. To prevent contact between the brushes and commutator as the commutator cover is installed, and possible damage to the brushes, lift the brush springs out of the notches in the brushes and pull the brushes back from the center of the commutator end cover. The springs will rest on the sides of the brushes and help prevent them from sliding towards the center of the cover (**Figure 12-7, Page 12-5**).
6. Install the commutator end cover (23) onto the armature shaft. Use the tapped mounting holes to align housing to the cover, rotate and orient as shown. Install the two M6 x 180 mm bolts (20), and tighten to 60 in·lb (6.8 N·m) (**Figure 12-3, Page 12-3**).
7. Push the brushes down into the holders. Place springs into the notches in the brushes. Install the brush cover (30) that has the drain hole in it next to the A2 terminal. Install the remaining three brush covers (29) in the openings in the commutator end cover (23) (**Figure 12-4, Page 12-3**).
8. Install the belt pulley (39) onto the shaft, and install the lock washer (40) and M14 nut (41). Tighten the nut to 30 ft·lb (40.7 N·m) (**Figure 12-8, Page 12-6**).
9. Install the A1 to F1 terminal jumper wire on the starter/generator.
  - 9.1. Loosely attach wire, flat washers, lock washers and nuts onto each terminal.
  - 9.2. Orient wire at A1 to be 1 inch (25.4 mm) away from A2 terminal as shown and tighten nut to 44 in·lb (5 N·m) (**Figure 12-14, Page 12-12**). **See following NOTE.**

**NOTE:** Secure bottom nut of terminal with wrench before tightening top nut.

- 9.3. Form wire against starter housing as shown and allow terminal at F1 to self-orient. Tighten nut to 44 in·lb (5 N·m). **See preceding NOTE.**

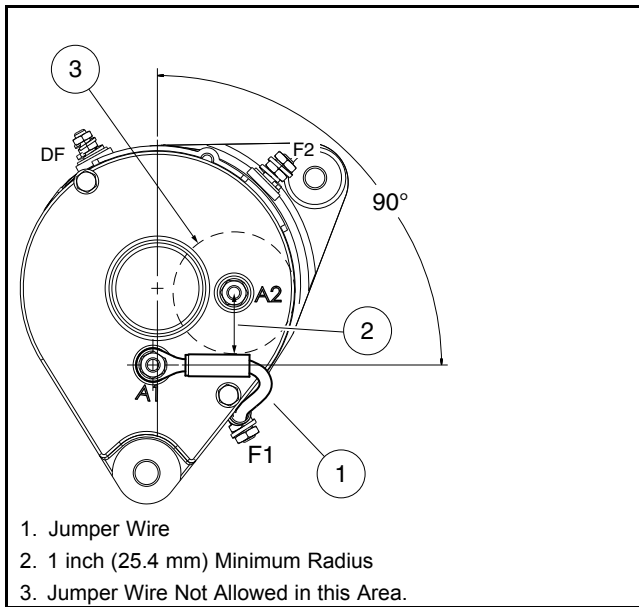

2687

**Figure 12-14 A1 to F1 Terminal Jumper Wire Routing**

## STARTER/GENERATOR INSTALLATION

1. Disable the vehicle.
2. Disconnect the battery and spark plug wire.
3. Install the green wire (1) from the F1 terminal to the A2 terminal on the starter/generator (**Figure 12-15**).

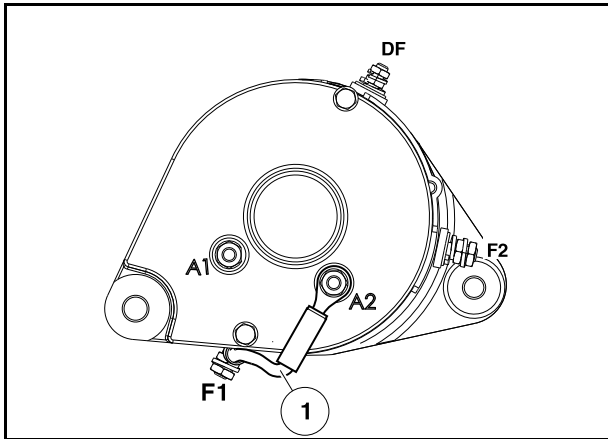

3033B

**Figure 12-15 Starter/Generator Green Wire**

4. Install a flat washer, lock washer, and nut onto each terminal and tighten to 48 in·lb (5.4 N·m).
5. Position the starter/generator over the mounting bracket.
6. Install the pivot bolts (2) and pivot nuts (1) (**Figure 12-16, Page 12-13**). Tighten the pivot nuts with your hand.

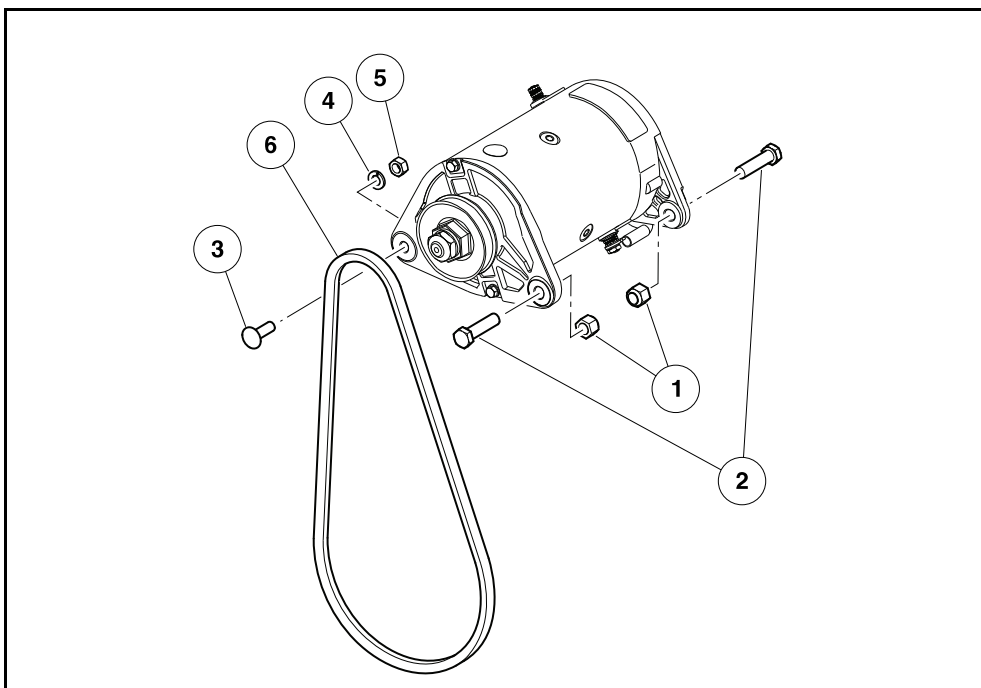

2997B

**Figure 12-16 Starter/Generator Installation**

7. Install the adjustment bolt (3), lock washer (4), and nut (5). Tighten the hardware with your hand.
8. Install starter/generator belt (6).

9. Adjust the belt tension. See Belt Tension Adjustment For EFI Engines.
10. Connect the yellow wire (7) from the voltage regulator to the DF terminal on the starter/generator (**Figure 12-17**).

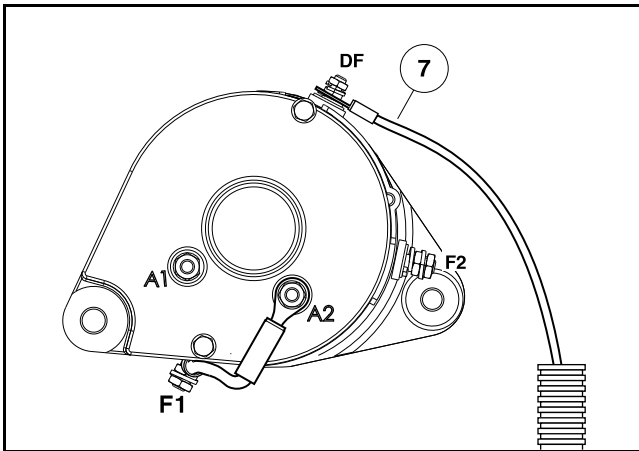

3033D

**Figure 12-17 Starter/Generator Yellow Wire**

11. Install a flat washer, lock washer, and nut onto the terminal. Tighten the nut to 31 in·lb (3.5 N·m).
12. Install the white wire (8) from the solenoid to the F2 terminal on the starter/generator (**Figure 12-18**).

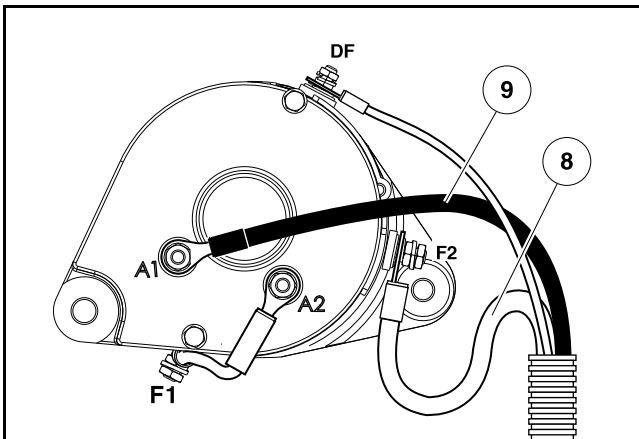

3033E

**Figure 12-18 Starter/Generator White and Black Wires**

13. Install the black wire (9) from the frame to the A1 terminal on the starter/generator.
14. Install a flat washer, lock washer and nut onto each terminal, and tighten the nut to 48 in·lb (5.4 N·m).
15. Connect the battery and spark plug wire.

## BELT TENSION INSPECTION FOR EFI ENGINES

**NOTE:** To prevent belt slipping while starting an EFI engine, follow procedure outlined below which is best performed by two people to expedite the process, but can be performed by a single individual if required.

*The amount a starter/generator belt is tensioned varies between a used and new belt.*

EFI engines have higher starting torque demands that require consistent belt tension to prevent slipping. Belt tension should be checked periodically.

## Existing Belts Only

1. Disconnect the battery and spark plug wire.
2. Mark a location on belt to repeat tension measurement each time. Use paint pen or permanent marker of light color.
3. Install a Universal Belt Tension Gauge (OTC® 6673 recommended) midway between the pulleys.

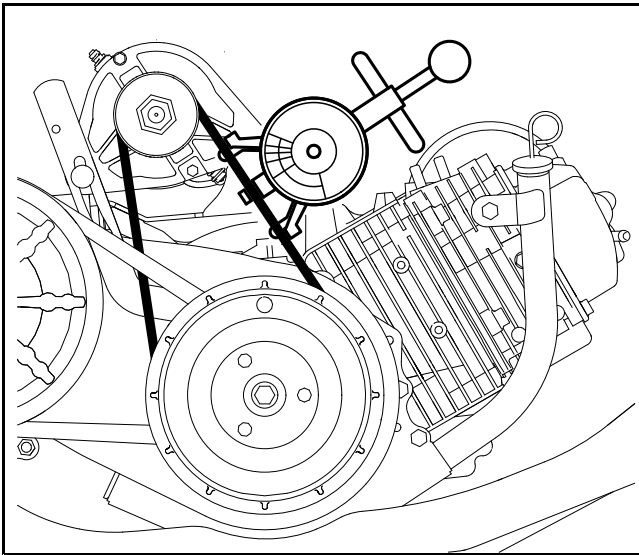

2724

**Figure 12-19 Belt Tension Gauge**

4. Measure the belt tension. Correct belt tension for a used starter/generator belt is 75 to 85 lbf (334 to 378 N).
  - 4.1. If the belt tension is within the accepted range, no further action is needed. Connect the battery and spark plug wire.
  - 4.2. If the belt tension is not within the accepted range, adjust the belt tension. See Belt Tension Adjustment For EFI Engines.

**BELT TENSION ADJUSTMENT FOR EFI ENGINES**

**NOTE:** To prevent belt slipping while starting an EFI engine, follow procedure outlined below which is best performed by two people to expedite the process, but can be performed by a single individual if required.

*The amount a starter/generator belt is tensioned varies between a used and new belt.*

EFI engines have higher starting torque demands that require consistent belt tension to prevent slipping. Belt tension should be checked periodically.

1. Disconnect the battery and spark plug wire.
2. Mark a location on belt to repeat tension measurement each time. Use paint pen or permanent marker of light color.
3. Install a Universal Belt Tension Gauge (OTC® 6673 recommended) midway between the pulleys.

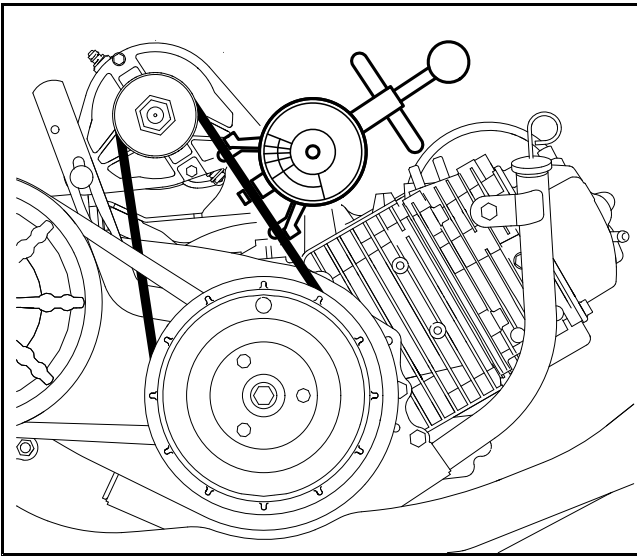

2724

**Figure 12-20 Belt Tension Gauge**

4. Tighten the adjustment nut (1) and pivot nut (2) with your hand (**Figure 12-21, Page 12-16**) .

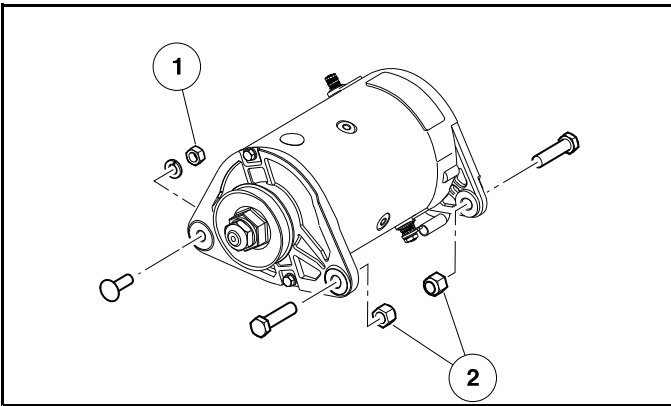

2997C

**Figure 12-21 Starter/Generator Mounting Hardware**

5. Install the belt tension tool.

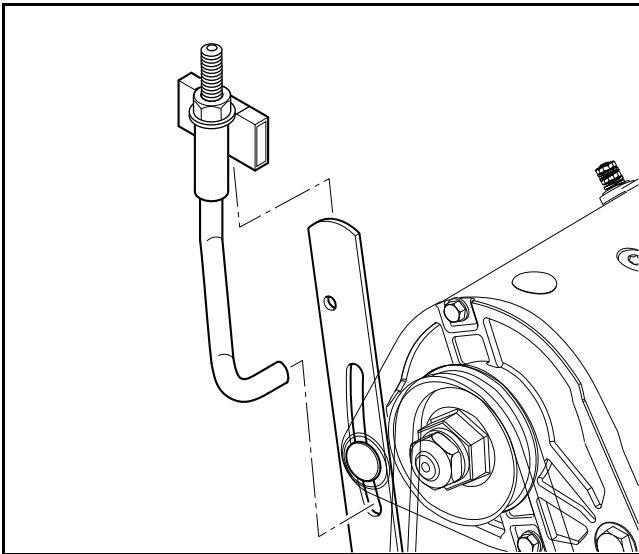

2725

**Figure 12-22 Belt Tensioning Tool Installation**

- 5.1. Carefully insert pry bar between starter/generator and bracket.

**NOTE:** In some cases, the threaded J-bolt of the belt tension tool does not have enough length to consistently fit under the starter/generator mounting ear. Fit can be greatly improved by modifying the tension tool. See *Belt Tension Tool Modification*.

- 5.2. Carefully lift the starter/generator up until tension tool can be installed as shown over the slotted adjustment bracket (**Figure 12-22, Page 12-17**). Note orientation of tension tool on the slotted adjustment bracket and how the threaded J-bolt is inserted into the slot under the starter/generator mounting ear.

- 5.3. Remove the pry bar.

6. Tension the belt.

- 6.1. Tighten the nut on belt tension tool 1/2 turn and check belt tension with the gauge.

**NOTE:** To prevent errors in measurement caused by residual tension, ensure to loosen, then reapply, the Universal Belt Tension gauge between measurements.

- 6.2. Continue to tighten in 1/2 turn increments until proper belt tension is achieved.
  - Proper tension for a **used** starter/generator belt is 75 to 85 lbf (334 to 378 N).
  - Proper tension for a **new** starter/generator belt is 120 to 130 lbf (534 to 578 N).

7. Seat the belt.

- 7.1. Remove all other tools.

- 7.2. The belt tension tool can be temporarily left in place.

- 7.3. Only connect the battery. **DO NOT CONNECT SPARK PLUG WIRE. See following WARNING.**

### **▲ WARNING**

- **Remove pry bar before starting engine.**
- **Ensure clearance between F2 terminal and starter/generator bracket before starting engine.**

- 7.4. Operate the engine a minimum of 5 seconds and a maximum of 15 seconds to fully seat the belt into pulleys and help eliminate any slack.

8. Repeat step 6..

9. Maintain tension and tighten the adjustment nut (1) to 15 to 18 ft·lb (20 to 24.5 N·m). Tighten the pivot nuts (2) to 20 to 25 ft·lb (27 to 34 N·m) (**Figure 12-23, Page 12-18**).

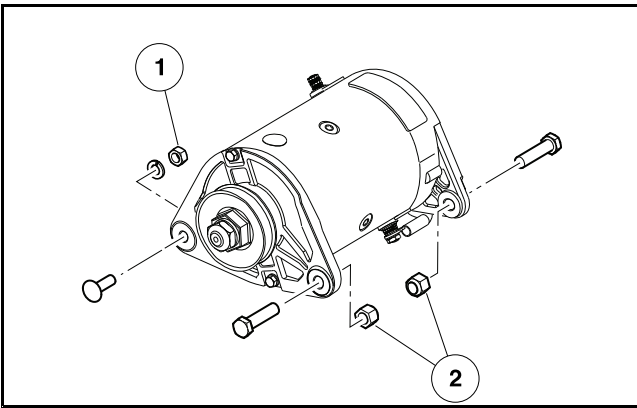

2997C

**Figure 12-23 Starter/Generator Mounting Hardware Installation**

10. Remove the belt tension tool.
11. Confirm proper belt tension with a final measurement.
12. Connect the spark plug wire.

### BELT TENSION TOOL MODIFICATION

1. Remove the nut and J-bolt from the bracket.
2. Grind or cut 3/8 to 1/2 inch (9.5 to 12.7 mm) (A) from bracket as shown to increase the effective length of the J-bolt (**Figure 12-24, Page 12-18**).

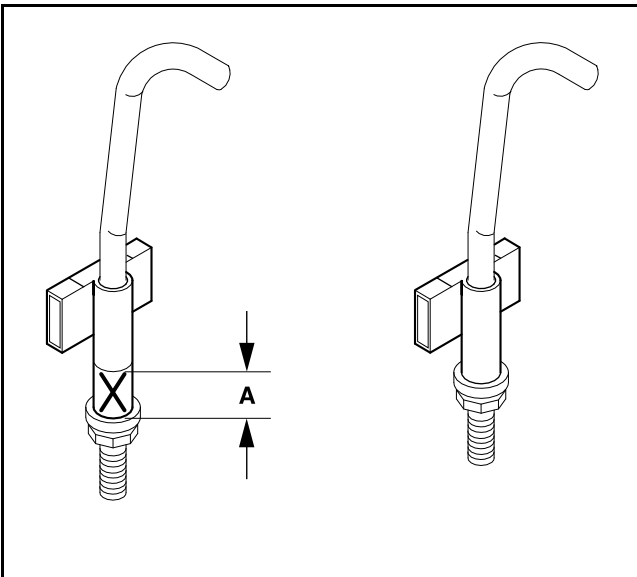

2726B

**Figure 12-24 Belt Tension Tool Modification (If Necessary)**

3. Install the J-bolt and nut into the bracket.



## VOLTAGE REGULATOR

### VOLTAGE REGULATOR REMOVAL

1. Disconnect the battery and spark plug wire.
2. Remove the electrical component box cover.
3. Disconnect the voltage regulator red wire (1) at the large post on the solenoid (**Figure 12-25**).

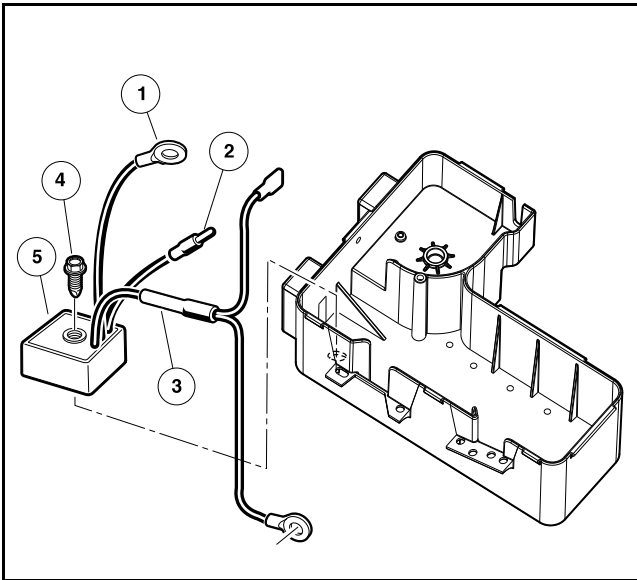

2973B

**Figure 12-25 Voltage Regulator**

4. Disconnect the yellow wire (2) at the bullet connector.
5. Disconnect the black wire (3) from the (NO) terminal of the kill limit switch and at the battery frame ground.
6. Remove the screw (4).
7. Remove the voltage regulator (5).

### VOLTAGE REGULATOR INSTALLATION

1. Position the voltage regulator (5) in the electrical component box (**Figure 12-25**).
2. Install the screw (4). Tighten the screw to 23 in·lb (2.6 N·m).
3. Connect the voltage regulator red wire (1) at the large post on the solenoid.
4. Connect the yellow wire (2) at the bullet connector.
5. Connect the black wire (3) at the battery frame ground.
6. Install the electrical component box cover. Be sure to firmly press down all corners.
7. Install the box cover screw and tighten to 18 in·lb (2 N·m).
8. Connect the battery and spark plug wire.
9. Set the Forward/Neutral/Reverse control (FNR) to N.
10. Set the Maintenance/Operate switch to MAINTENANCE.
11. Start the engine.
12. Make sure that the voltage regulator operates correctly. See the test procedure for voltage regulator.

## KEY SWITCH

### KEY SWITCH REMOVAL

1. Disconnect the battery and spark plug.
2. Remove the instrument panel.

**NOTE:** Take care to prevent key switch terminals and wires from touching the metal frame around the dash.

3. Disconnect the wires from the key switch. Do not allow wires to touch.
4. From the back of the instrument panel, push down on the retaining tabs (1) and remove the key switch cap (2) (Figure 12-26, Page 12-20).

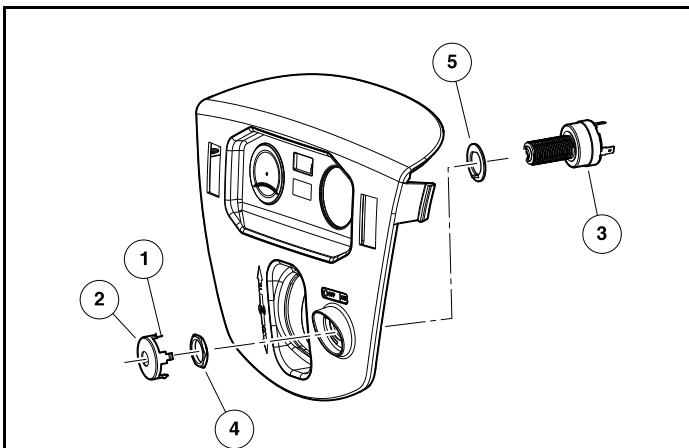

2931B

Figure 12-26 Key Switch Removal

5. Hold the key switch (3) and remove the switch retaining nut (4).
6. Remove the key switch and washer (5).

## KEY SWITCH INSTALLATION

1. Install the key switch (1) and washer (2) into the instrument panel (**Figure 12-27, Page 12-21**).

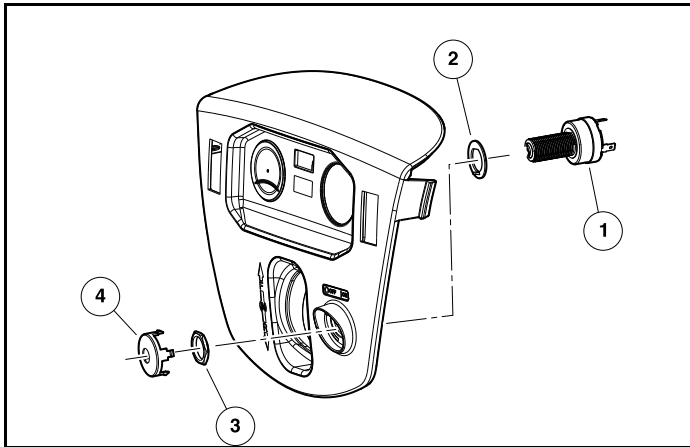

2931C

**Figure 12-27 Key Switch Installation**

2. Install the key switch nut (3). Tighten the nut to 35 to 45 in·lb (4 to 5 N·m).
3. Install key switch cap (4) into instrument panel.
4. Connect the wires to the key switch terminals. See the following table.

### Key Switch Terminals

Terminal	Wire Color
1	Brown / White
2	Green
-M	Black
+M	Red / Yellow

5. Install the instrument panel.
6. Connect the battery and spark plug.

## MAINTENANCE/OPERATE SWITCH

### MAINTENANCE/OPERATE SWITCH REMOVAL

1. Disconnect the battery and spark plug wire.
2. Remove the boot/hex nut (1) (**Figure 12-28**).

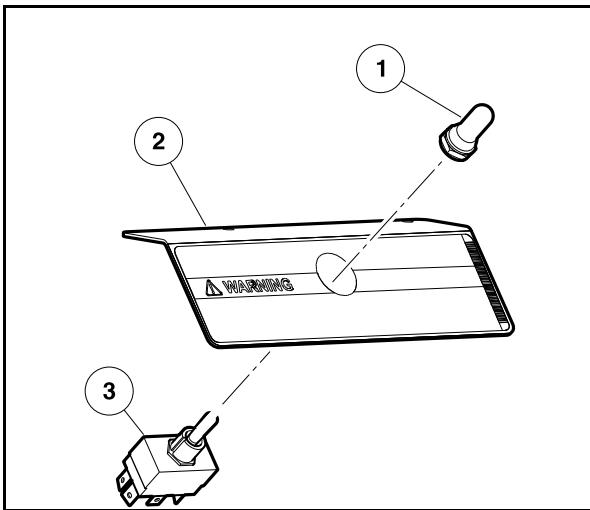

000755-004

Figure 12-28 Maintenance/Operate Switch

3. Remove the Maintenance/Operate switch (2) from bracket (3).
4. Disconnect the wires and remove Maintenance/Operate switch.

## MAINTENANCE/OPERATE SWITCH INSTALLATION

1. Connect the wires to the Maintenance/Operate switch.

### Switch Terminals

Terminal	Wire Color
T1	Black / Pink
T2	Black
T3	Black / Yellow

2. Make sure that the groove switch is aligned with tang on bracket (3) and install the Maintenance/Operate switch (2) (Figure 12-29, Page 12-22).

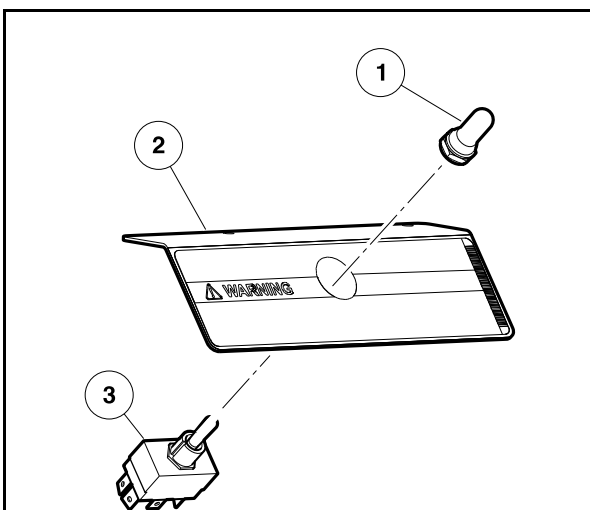

000755-004

Figure 12-29 Maintenance/Operate Switch

3. Install the boot/hex nut (1). Tighten the boot/hex nut to 16 in·lb (1.8 N·m).
4. Connect the battery.

## NEUTRAL LOCKOUT LIMIT SWITCH

### NEUTRAL LOCKOUT LIMIT SWITCH REMOVAL

#### On Transaxle

1. Disable the vehicle.
2. Disconnect the battery and spark plug wire.
3. Disconnect the 3-wire connector from the neutral lockout limit switch (1) (**Figure 12-30**).

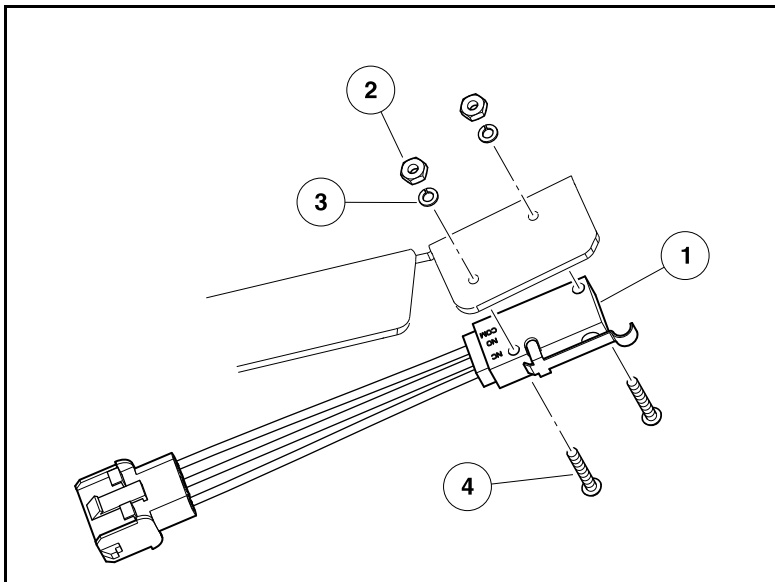

000999-003

**Figure 12-30** Transaxle - Neutral Lockout Limit Switch

4. Remove the nuts (2), washers (3), and bolts (4).
5. Remove the neutral lockout limit switch.

#### On FNR

1. Disable the vehicle.
2. Disconnect the battery and spark plug wire.
3. Remove the instrument panel.
4. Disconnect the 3-wire connector from the neutral lockout limit switch (1) (**Figure 12-31**).

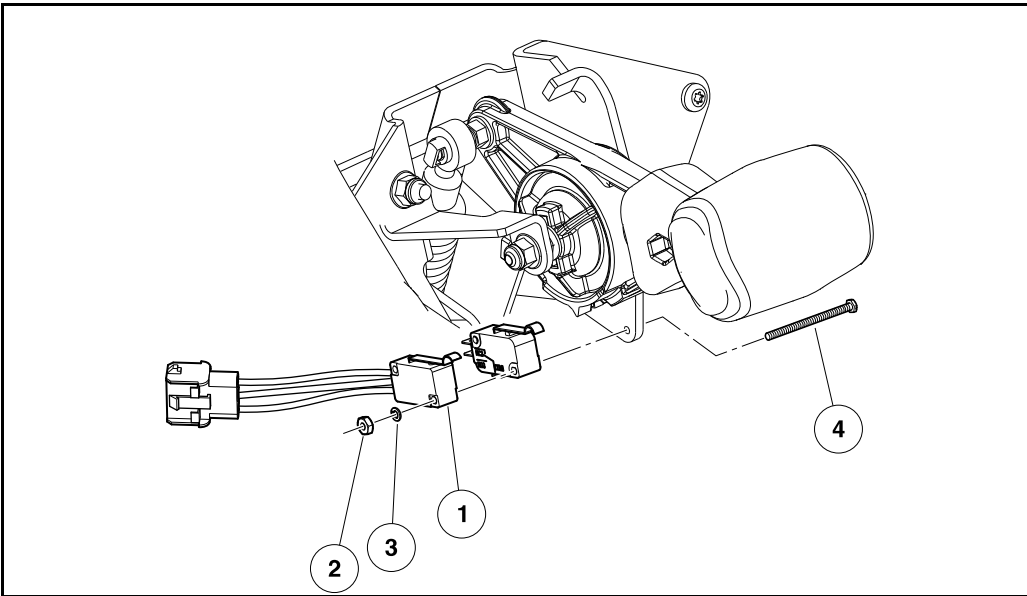

000999-004

**Figure 12-31 FNR - Neutral Lockout Limit Switch**

5. Remove the nut (2), washer (3), and bolt (4).
6. Remove the neutral lockout limit switch.

## NEUTRAL LOCKOUT LIMIT SWITCH INSTALLATION

### **⚠ CAUTION**

- Do not overtighten the retaining nuts. If the nuts are overtightened, limit switches could be damaged.

#### On Transaxle

1. Install the limit switch (1) with the screws (4), washers (3), and nuts (2). Tighten the hardware to 5 in·lb (0.6 N·m) (**Figure 12-32**).

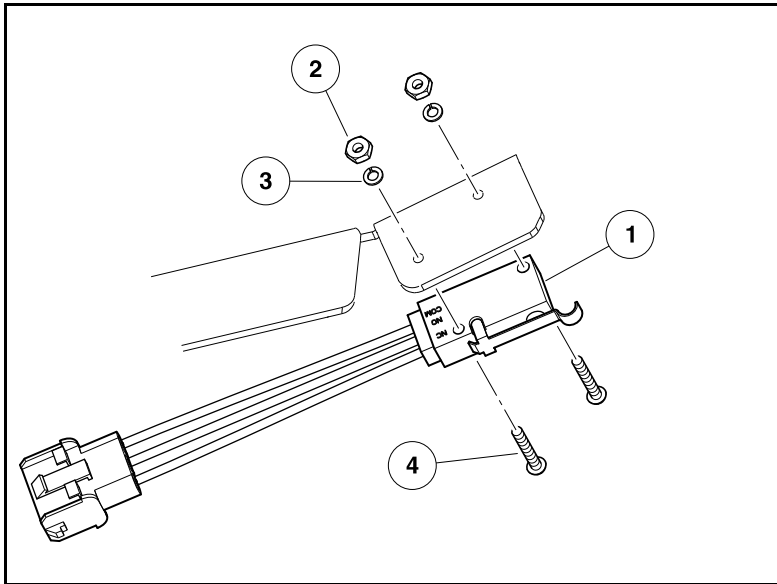

000999-003

**Figure 12-32 Transaxle - Neutral Lockout Limit Switch**

2. Move the Forward/Neutral/Reverse control (FNR) to make sure that the switch actuates.
3. Connect the 3-wire connector to the neutral lockout limit switch lead.
4. Connect the battery and spark plug wire.
5. Test drive the vehicle in both forward and reverse for proper operation.

**On FNR**

1. Install the limit switch (1) with the bolt (4), washer (3), and nut (2). Tighten the hardware to 5 in-lb (0.6 N·m) (**Figure 12-33**).

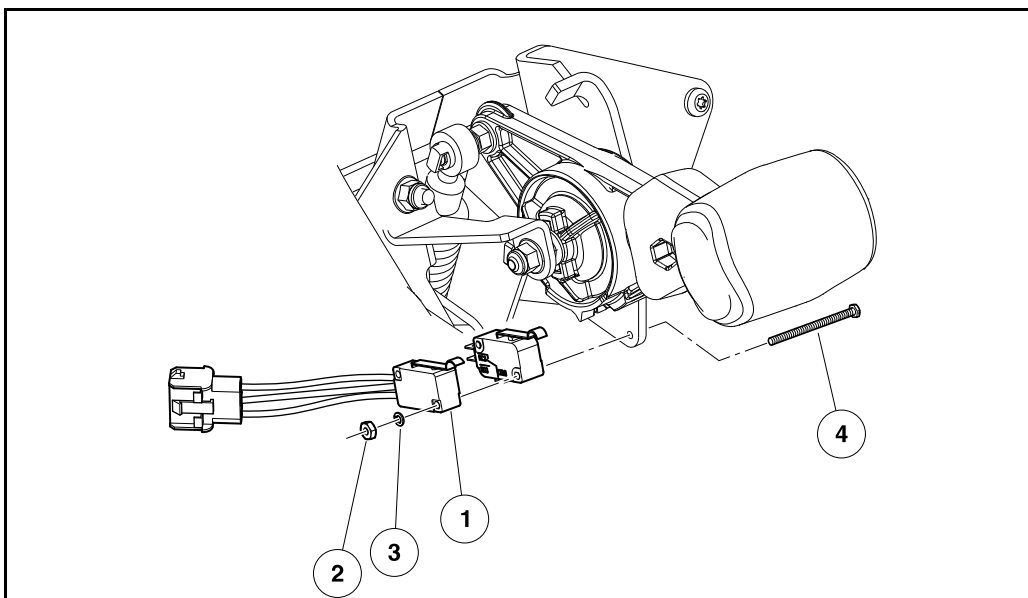

000999-004

**Figure 12-33 FNR - Neutral Lockout Limit Switch**

2. Move the Forward/Neutral/Reverse control (FNR) to make sure the switch actuates
3. Connect the 3-wire connector to the neutral lockout limit switch lead.

4. Connect the battery and spark plug wire.
5. Test drive the vehicle in both forward and reverse for proper operation.

## SOLENOID

### SOLENOID REMOVAL

1. Disconnect the battery and spark plug wire.
2. Remove the electrical component box cover (1) (Figure 12-34).

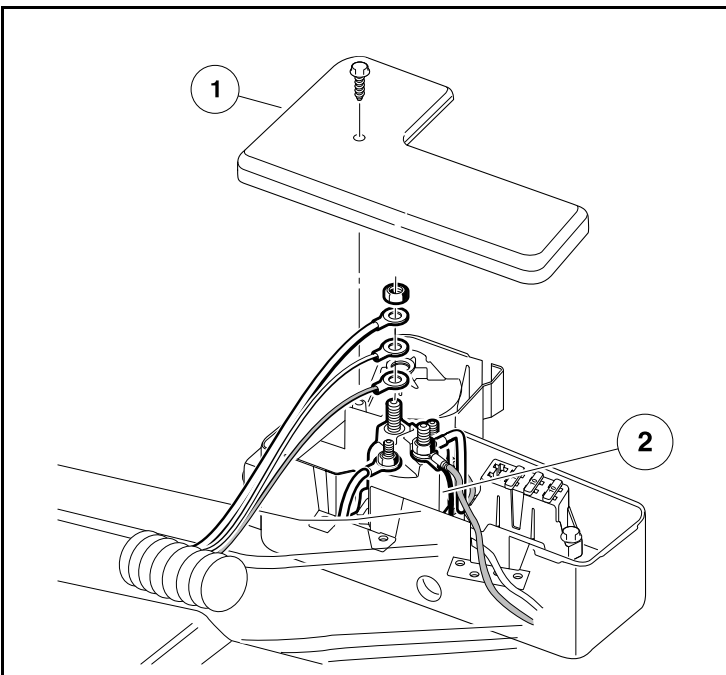

3025C

Figure 12-34 Solenoid Wires

3. Disconnect the wires from the solenoid (2).
4. Remove the screws (3) from the solenoid (Figure 12-35).



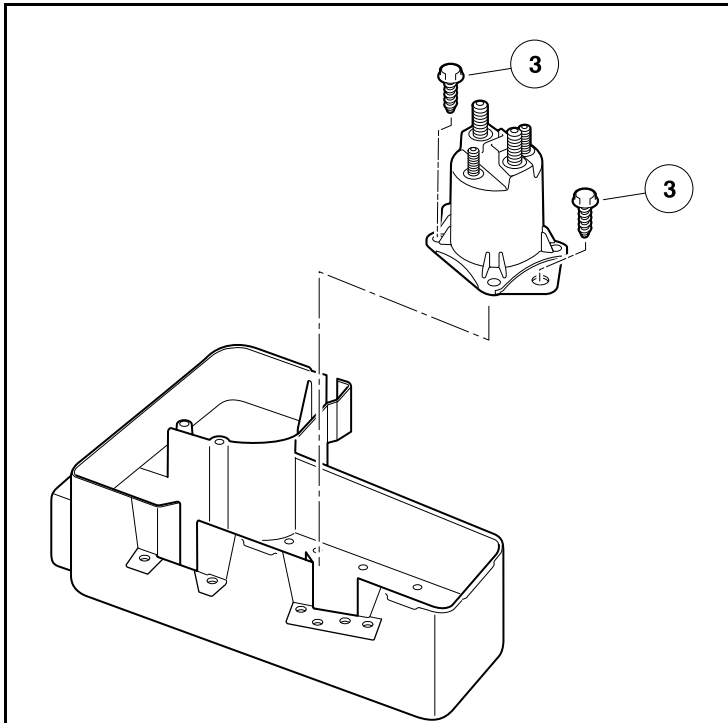

001014-003

**Figure 12-35 Solenoid Screws**

5. Remove the solenoid.

## SOLENOID INSTALLATION

1. Install the solenoid in the electrical component box.
2. Install the screws (1) (**Figure 12-36**). Tighten the screws to 14 in·lb (1.6 N·m).

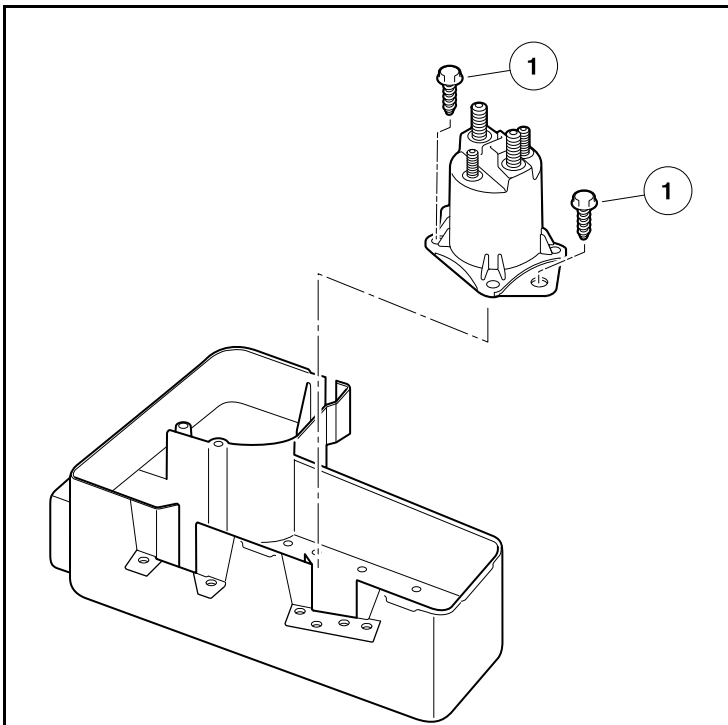

001014-004

**Figure 12-36 Solenoid Screws**

3. Connect the 4 gauge white wire, 18 gauge white wire, and the 18 gauge red wire to the large post.
4. Connect the 4-gauge red wire, 10-gauge red wire, and 16-gauge orange wire to the other large post on the solenoid.
5. Connect the 18 gauge orange wire to the small post on the solenoid.
6. Connect the 18 gauge blue wire to the other small post on the solenoid.
7. Install the nuts on the large solenoid posts. Tighten the nuts to 60 in·lb (6.8 N·m).
8. Install the nuts on the small solenoid posts. Tighten the nuts to 22 in·lb (2.5 N·m).
9. Install the electrical box cover.
10. Connect the battery and spark plug wire.

## FUSE

ATC-style fuses are located inside the electrical component box near the battery.

ATM-style fuses are located on the main wire harness in front of the engine.

## FUSE REMOVAL

1. Disconnect the battery.
2. **ATC Fuse Only:** Remove electrical component box cover cover.  
**ATM Fuse Only:** Remove fuse holder cover.
3. Remove the fuse from the fuse block.

## FUSE INSTALLATION

1. Install the fuse. See following **WARNING**.

### **⚠ WARNING**

- If a fuse is blown, determine the cause of the failure and make necessary repairs before installing a new fuse. Use the appropriately rated fuse; if a fuse with a higher amp rating is used, damage to the vehicle electrical system may occur.
2. **ATC Fuse Only:** Install the snap-on electrical box cover by pressing down firmly on all corners and install the screw, tightening to 18 in·lb (2 N·m).  
**ATM Fuse Only:** Install the fuse holder cover.
  3. Connect the battery.

## ACCELERATOR PEDAL LIMIT SWITCH

### ACCELERATOR PEDAL LIMIT SWITCH REMOVAL

1. Disconnect the battery and spark plug wire.
2. Remove the screw (1) (**Figure 12-37**).

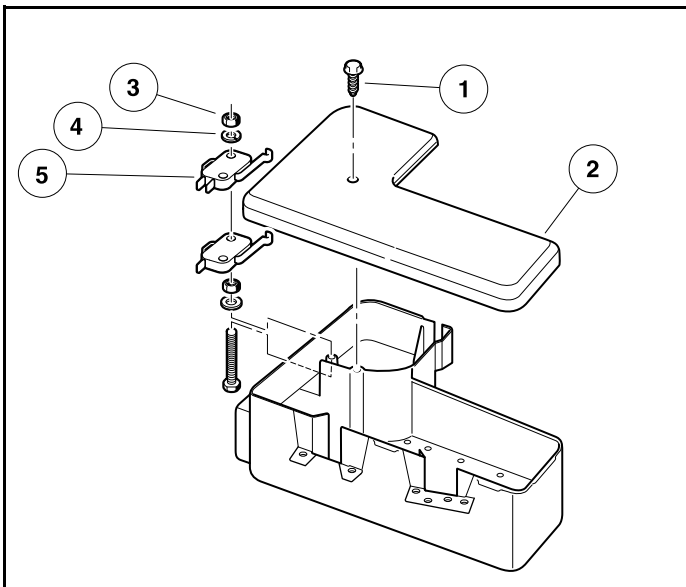

2948D

**Figure 12-37 Accelerator Pedal Limit Switch**

3. Remove the electrical component box cover (2).
4. Remove the two nuts (3) and washers (4).
5. Disconnect the wires from the accelerator pedal limit switch (5).
6. Remove the accelerator pedal limit switch.

### ACCELERATOR PEDAL LIMIT SWITCH INSTALLATION

1. Connect the green wire to the common (COM) terminal.
2. Connect the pink wire to the normally closed (NC) terminal.
3. Install the two washers (4) and two nuts (3) (**Figure 12-37, Page 12-30**). Tighten the nuts to 5 in·lb (0.6 N·m). **See following CAUTION.**

### **⚠ CAUTION**

- **Do not overtighten the retaining nuts. If the nuts are overtightened, limit switches could be damaged.**
4. Press and release the accelerator pedal to make sure that both switches are being activated when the pedal is released.
  5. Install the electrical component box cover (2). Be sure to press down firmly all corners. Install the screw (1). Tighten the screw to 18 in·lb (2 N·m).
  6. Connect the battery and spark plug wire.

## KILL LIMIT SWITCH

### KILL LIMIT SWITCH REMOVAL

1. Disconnect the battery and spark plug wire.
2. Remove the screw (1) (Figure 12-38).

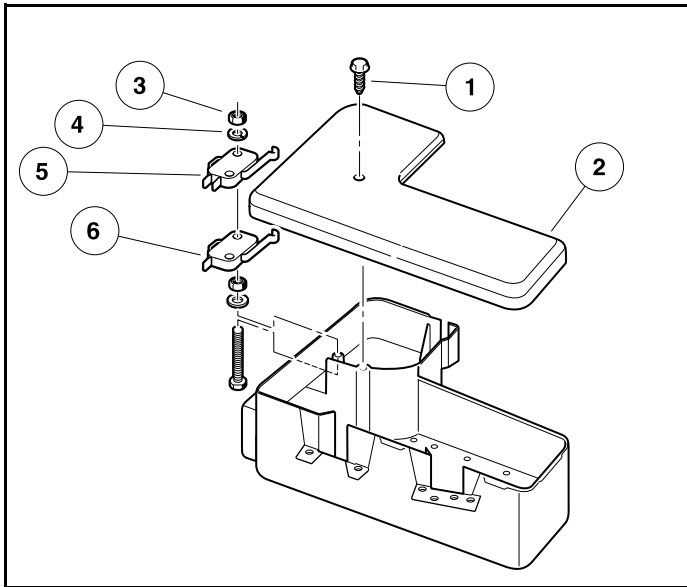

2948E

Figure 12-38 Kill Limit Switch

3. Remove the electrical component box cover (2).
4. Remove the two nuts (3) and washers (4).
5. Remove the accelerator pedal limit switch (5). Do not disconnect the wires attached to accelerator pedal limit switch.
6. Disconnect the wires from the kill limit switch (6).
7. Remove the kill limit switch.

### KILL LIMIT SWITCH INSTALLATION

1. Connect the white/black wire to the common (COM) terminal.
2. Connect the blue wire to the normally open (NO) terminal.
3. Install the kill limit switch (6) on the mounting screws (Figure 12-38, Page 12-31).
4. Install the accelerator limit switch (5) on the mounting screws.
5. Install the two washers (4) and two nuts (3). Tighten the nuts to 5 in·lb (0.6 N·m). **See following CAUTION.**

### **⚠ CAUTION**

- Do not overtighten the retaining nuts. If the nuts are overtightened, limit switches could be damaged.
6. Press and release the accelerator pedal to make sure that both switches are being activated when the pedal is released.

7. Install the electrical component box cover (2). Be sure to press down firmly all corners.
8. Install the screw (1). Tighten the screw to 18 in·lb (2 N·m).
9. Connect the battery and spark plug wire.

## REVERSE WARNING BUZZER

### REVERSE WARNING BUZZER REMOVAL

1. Disconnect the battery and spark plug wire.
2. Remove the instrument panel (1) (**Figure 12-39, Page 12-32**).

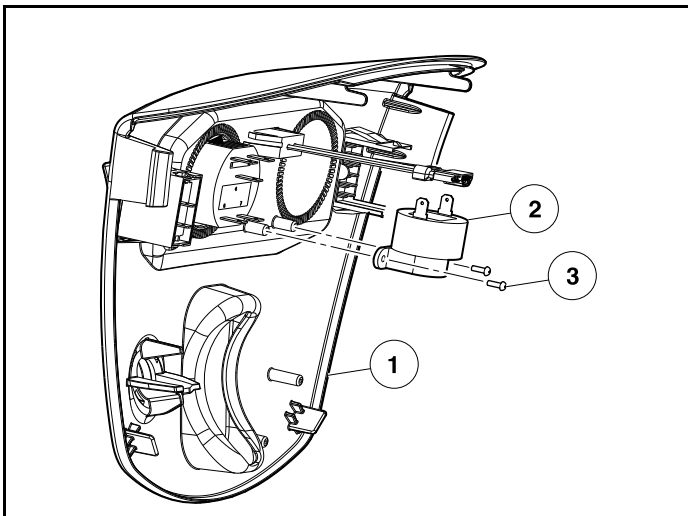

3003B

**Figure 12-39 Reverse Warning Buzzer**

3. Disconnect the wires from the reverse warning buzzer (2). Do not let the wires touch.
4. Remove the mounting screws (3).
5. Remove the reverse buzzer.

### REVERSE WARNING BUZZER INSTALLATION

1. Install the reverse buzzer (2) on the instrument panel (1) (**Figure 12-39, Page 12-32**).
2. Install the screws (3). Tighten the screws to 3.5 in·lb (0.40 N·m).
3. Connect the black wire from the key switch to the negative (-) terminal.
4. Connect the orange/white wire from the wire harness to the positive (+) terminal.
5. Install the instrument panel. Make sure that the key switch terminals cannot touch the frame. Make sure that the panel is properly seated and snapped in place.
6. Connect the battery and spark plug wire.

## REVERSE BUZZER LIMIT SWITCH

### REVERSE BUZZER LIMIT SWITCH REMOVAL

1. Disconnect the battery and spark plug wire.
2. Remove the instrument panel.
3. Cut the wire tie that retains the limit switch leads to the instrument panel harness.
4. Remove the nuts (1) and washers (2) (**Figure 12-40, Page 12-33**).

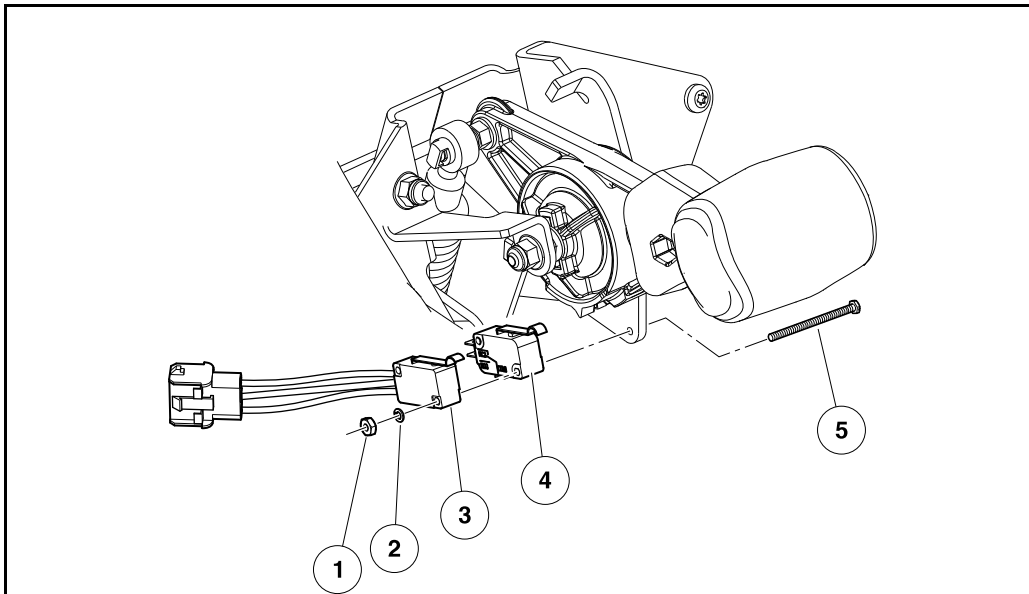

000999-005

**Figure 12-40 Reverse Buzzer Limit Switch**

5. Disconnect the neutral lockout limit switch (3).
6. Remove the neutral lockout limit switch.
7. Disconnect the wires from the reverse buzzer limit switch (4).
8. Remove the screws (5) and reverse buzzer limit switch.

### REVERSE BUZZER LIMIT SWITCH INSTALLATION

1. Install the reverse buzzer switch (4) with two screws (5) (**Figure 12-40, Page 12-33**).
2. Install the neutral lockout limit switch (3).
3. Install the washers (2) and nuts (1). Tighten the nuts to 5 in·lb (0.6 N·m). **See following CAUTION.**

#### **⚠ CAUTION**

- **Do not overtighten the retaining nuts. If the nuts are over tightened, limit switches could be damaged.**

4. Connect the wires to the reverse buzzer limit switch.
5. Connect the neutral lockout limit switch.
6. Set the Forward/Neutral/Reverse control (FNR) to R. Make sure that both switches actuate.

7. Connect the battery and spark plug wire.
8. Turn the key switch to the ON position.
9. Set the FNR to R. Make sure that the buzzer sounds.

## LOW OIL WARNING LIGHT

### LOW OIL WARNING LIGHT REMOVAL

1. Disconnect the battery and spark plug wire.
2. Remove the instrument panel.
3. Disconnect the low oil warning light (1) wires (**Figure 12-41, Page 12-34**). Do not allow wires to touch.

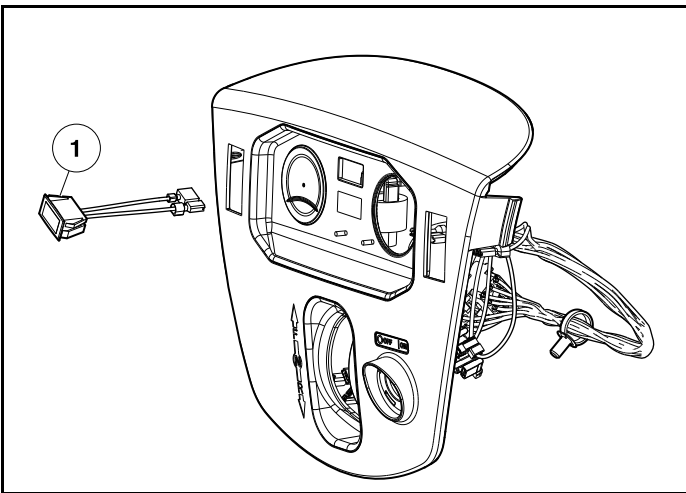

3003C

**Figure 12-41 Low Oil Warning Light**

4. Push the retaining tabs and remove the low oil warning light from the instrument panel.

### LOW OIL WARNING LIGHT INSTALLATION

1. Install the low oil warning light (1) in the instrument panel until plastic tabs engage instrument panel (**Figure 12-41, Page 12-34**).
2. Connect the low oil warning light (1) wires.
3. Install the instrument panel. Make sure that the key switch terminals cannot touch the frame. Make sure that the instrument panel is correctly seated and snapped in place.
4. Connect the battery and spark plug wire.



## MALFUNCTION INDICATOR LIGHT

### MALFUNCTION INDICATOR LIGHT REMOVAL

1. Disconnect the battery and spark plug wire.
2. Remove the instrument panel.
3. Disconnect the malfunction indicator light (1) wires (**Figure 12-42, Page 12-35**). Do not allow wires to touch.

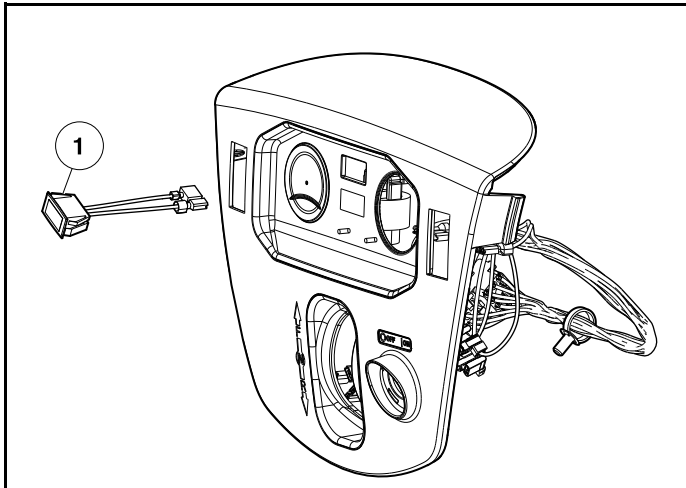

3003C

**Figure 12-42 Malfunction Indicator Light**

4. Push the retaining tabs and remove the malfunction indicator light from the instrument panel.

### MALFUNCTION INDICATOR LIGHT INSTALLATION

1. Install the malfunction indicator light (1) in the instrument panel until plastic tabs engage instrument panel (**Figure 12-42, Page 12-35**).
2. Connect the malfunction indicator light (1) wires.
3. Install the instrument panel. Make sure that the key switch terminals cannot touch the frame. Make sure that the instrument panel is correctly seated and snapped in place.
4. Connect the battery and spark plug wire.

## FUEL GAUGE/HOUR METER

### GENERAL INFORMATION

With the key switch in the OFF position, the fuel gauge field is blank; however, the hour meter field is always ON. When the key switch is turned to ON, the fuel gauge field activates. The fuel gauge initially registers full before indicating the actual fuel level.

The hour meter displays the number of hours of use in increments of 0.1 (one tenth) hour, but does not record additional time unless the key switch is in the ON position and the engine is on. When recording, the hourglass icon on the left blinks.

## FUEL GAUGE/HOUR METER REMOVAL

1. Disconnect the battery and spark plug wire.
2. Remove the instrument panel.
3. Disconnect the fuel gauge/hour meter (1) wires (**Figure 12-43, Page 12-36**). Do not allow wires to touch.

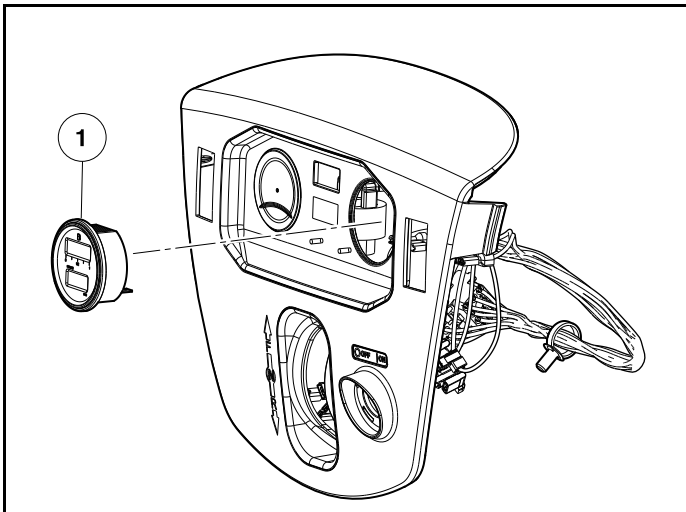

3003D

**Figure 12-43 Fuel Gauge/Hour Meter**

4. Alternate pulling the lower and upper tabs away from the gauge housing to remove clip.
5. Remove gauge/meter from the instrument panel.

## FUEL GAUGE/HOUR METER INSTALLATION

1. Install the fuel gauge/hour meter (1) into the hole in the instrument panel until the flange seats against the instrument panel (**Figure 12-43, Page 12-36**).
2. Connect the wires to the fuel gauge/hour meter.
3. Install the instrument panel. Make sure that the key switch terminals cannot touch the frame. Make sure that the instrument panel is properly seated and snapped in place.
4. Connect the battery and spark plug wire.

## FUEL LEVEL SENDING UNIT

The fuel level sending unit is an integral part of the fuel pump module and is not replaceable. Thoroughly test the fuel level sending unit before replacing the fuel pump module.

## VOLTAGE LIMITER

### VOLTAGE LIMITER REMOVAL

**NOTE:** Battery will charge reducing the voltage going to accessories.

The voltage limiter is located on the driver side cowl frame.

1. Disable the vehicle.
2. Disconnect the battery and spark plug wire.
3. Remove the cowl.
4. Disconnect the voltage limiter wires (1) (**Figure 12-44, Page 12-37**). Do not allow wires to touch.

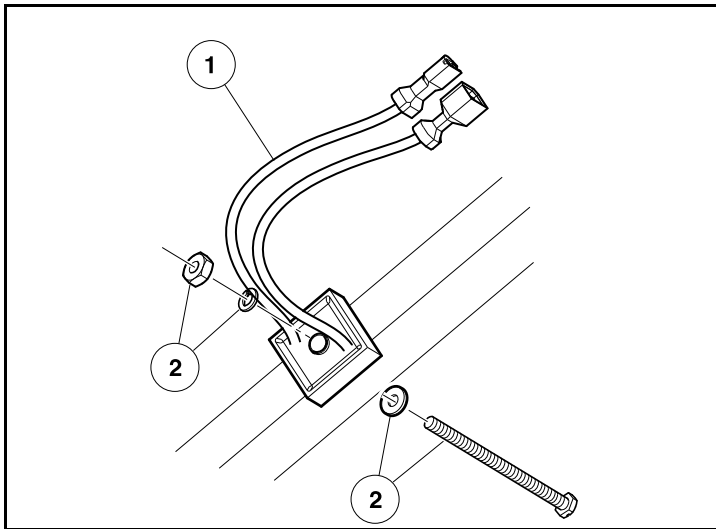

3002B

**Figure 12-44 Voltage Limiter**

5. Remove the hardware (2).
6. Remove the voltage limiter.

### VOLTAGE LIMITER INSTALLATION

1. Install the voltage limiter to the driver side cowl frame.
2. Install the hardware (2). Tighten the hardware to 25 in·lb (2.8 N·m) (**Figure 12-44, Page 12-37**).
3. Connect the voltage limiter green wire to the harness green wire.
4. Connect the voltage limiter black wire to the harness black wire.
5. Install the cowl.
6. Connect the battery and spark plug wire.

## HEADLIGHT SWITCH

### HEADLIGHT SWITCH REMOVAL

1. Disconnect the battery and spark plug wire.
2. Remove the instrument panel.
3. Disconnect the wires from the headlight switch (1) (**Figure 12-45**).

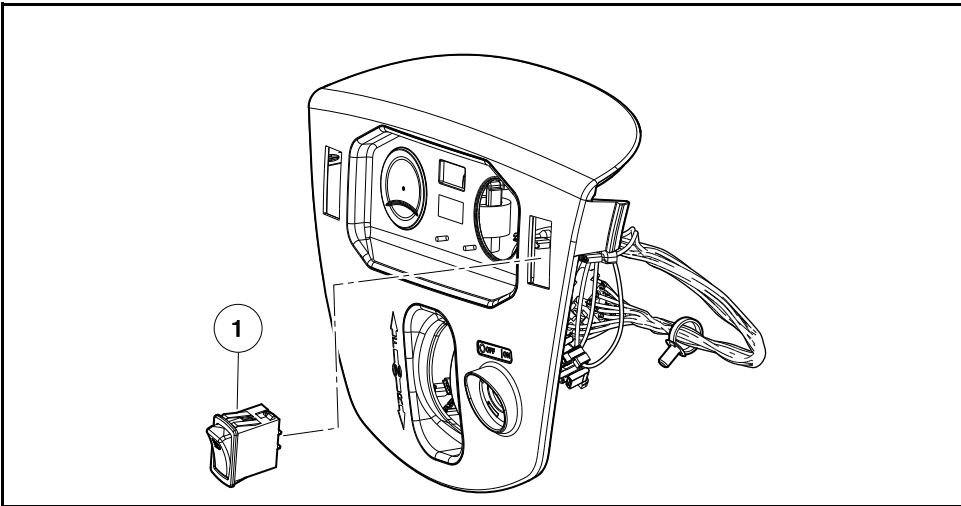

3003E

**Figure 12-45** Headlight Switch

4. Push the tabs and remove the headlight switch from the instrument panel.

### HEADLIGHT SWITCH INSTALLATION

1. Connect the wires to the headlight switch (1) (**Figure 12-45**).
2. Install the headlight switch into instrument panel.
3. Install the instrument panel. Make sure that the key switch terminals cannot touch the frame. Make sure that the instrument panel is properly seated and snapped in place.
4. Connect the battery and spark plug wire.

## HEADLIGHTS

### HEADLIGHT BEZEL REMOVAL

1. Disconnect the battery
2. Remove the cowl.
3. Remove the front fender.
4. Disconnect the headlight and turn signal electrical connectors.
5. Remove the bolts (1) (**Figure 12-46, Page 12-39**).

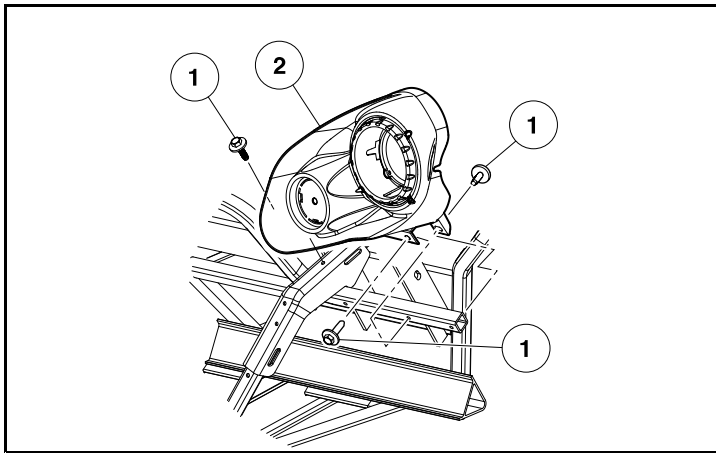

Figure 12-46 Headlight Bezel

6. Remove the headlight bezel (2).

### HEADLIGHT BEZEL INSTALLATION

1. Install the headlight bezel (2) to vehicle frame (**Figure 12-46, Page 12-39**).
2. Install the bolts (1). Tighten the bolts to 44 in·lb (5 N·m).
3. Connect the headlight bulb and turn signal electrical connectors.
4. Install the front fenders.
5. Install the cowl.
6. Connect the battery.

## HALOGEN HEADLIGHT BULB REMOVAL

### **CAUTION**

- Do not touch the glass part of the headlight bulb. Oil from fingertips can decrease the life of the headlight bulb.

1. Disconnect the battery
2. Remove the cowl.
3. Lift the tabs on the connector harness to release the electrical connector from the headlight bulb (1) (Figure 12-47, Page 12-40).

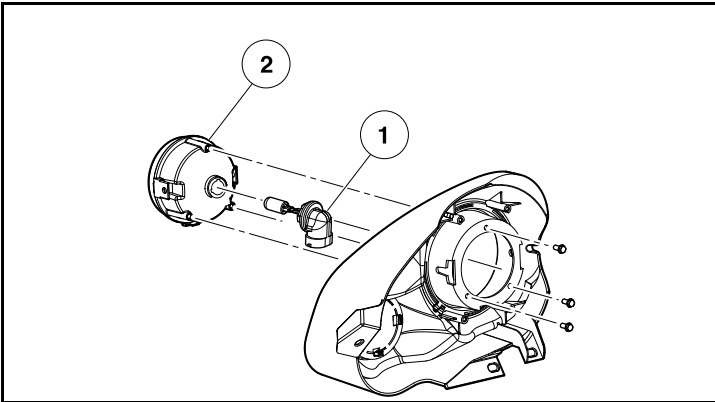

2993C

Figure 12-47 Halogen Headlight Bulb

4. Turn the headlight bulb clockwise 1/4 (one-quarter) turn. Remove the headlight bulb from the headlight assembly (2).

## HALOGEN HEADLIGHT BULB INSTALLATION

### **CAUTION**

- Do not touch the glass part of the headlight bulb. Oil from fingertips can decrease the life of the headlight bulb.

1. Install the headlight bulb (1) into the headlight lens (2) (Figure 12-47, Page 12-40).
2. Install the electrical connector onto the headlight bulb.
3. Connect the battery.
4. Install the cowl.

## HALOGEN HEADLIGHT LENS REMOVAL

### **CAUTION**

- Do not touch the glass part of the headlight bulb. Oil from fingertips can decrease the life of the headlight bulb.

1. Disconnect the battery
2. Remove the cowl.
3. Lift the tabs on the connector harness to release the electrical connector from the headlight bulb (1) (Figure 12-48, Page 12-41).

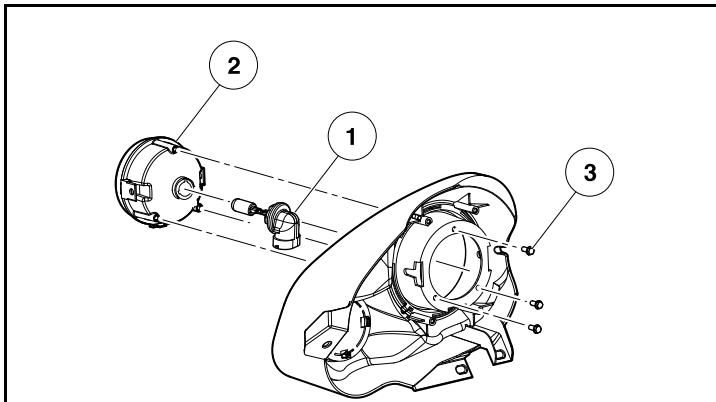

2993D

Figure 12-48 Halogen Headlight Lens

4. Turn the headlight bulb clockwise 1/4 (one-quarter) turn. Remove the headlight bulb from the headlight lens (2).
5. Remove the screws (3).
6. Remove the headlight lens.

## HALOGEN HEADLIGHT LENS INSTALLATION

### **CAUTION**

- Do not touch the glass part of the headlight bulb. Oil from fingertips can decrease the life of the headlight bulb.

1. Install the headlight lens (2) into the headlight bezel (Figure 12-48, Page 12-41).
2. Install the screws (3). Tighten the screws to 22 in·lb (2.5 N·m).
3. Install the headlight bulb (1) into the headlight lens.
4. Install the electrical connector onto the headlight bulb.
5. Connect the battery.
6. Install the cowl.

## LED HEADLIGHT REMOVAL

1. Disconnect the battery.
2. Remove the cowl.
3. Lift the tabs on the connector harness to release the electrical connector from the LED headlight (1) (**Figure 12-49, Page 12-42**).

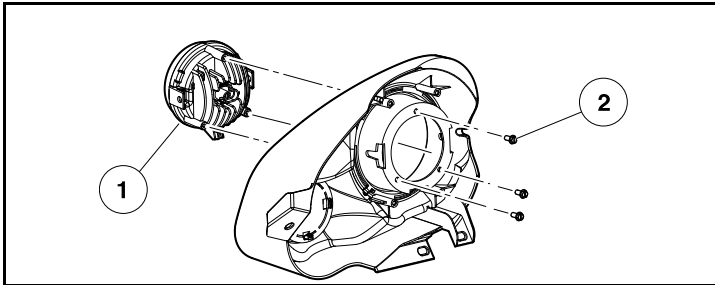

2993E

Figure 12-49 LED Headlight

4. Remove the screws (2).
5. Remove the LED headlight.

## LED HEADLIGHT INSTALLATION

1. Install the LED headlight (1) into the headlight bezel (**Figure 12-49, Page 12-42**).
2. Install the screws (2). Tighten the screws to 22 in·lb (2.5 N·m).
3. Install the electrical connector onto the LED headlight.
4. Connect the battery.
5. Install the cowl.

## BATTERY

### **⚠ DANGER**

- Due to the danger of an exploding battery, wear a full face shield and rubber gloves when working on or near batteries.
- **Battery – Explosive gases! Do not smoke. Keep sparks and flames away from the vehicle and service area. Ventilate when charging or operating vehicle in an enclosed area. Wear a full face shield and rubber gloves when working on or near batteries.**
- Tools, wires, and metal objects can cause sparks when shorted across a battery.
- Follow all instructions carefully when working with batteries.
- Charge battery in a well-ventilated area only.

DANGER CONTINUED ON NEXT PAGE



## **⚠ DANGER**

- **Battery – Poison! Contains acid! Causes severe burns. Avoid contact with skin, eyes, or clothing. Antidotes:**
  - **External: Flush with water. Call a physician immediately.**
  - **Internal: Drink large quantities of milk or water followed with milk of magnesia or vegetable oil. Call a physician immediately.**
  - **Eyes: Flush with water for 15 minutes. Call a physician immediately.**

## **⚠ WARNING**

- **Do not jump start a dead battery using another battery and jumper cables.**

## **GENERAL INFORMATION**

See preceding **DANGER** and **WARNING** statements.

Gasoline vehicles are equipped with a 12-volt battery. When changing a 12-volt battery in any gasoline-powered vehicle, the same size battery with adequate amperage ratings should be used as a replacement.

A group 26, top-post battery, with a 525 cold cranking amp rating and a reserve capacity of at least 85 minutes is recommended. The group 26 classification indicates battery size: 8 inches W x 6-3/4 inches D x 7 inches H (20.3 cm W x 17.2 cm D x 17.8 cm H). It is important to use the proper size to ensure that the battery clamp will fit correctly.

## **PREVENTIVE MAINTENANCE**

1. To keep the battery in good operating condition, remove any corrosion immediately. Post connections should be clean and tight. Any frayed or worn wires should be replaced. After all cables have been connected and properly tightened to 41 in·lb (4.3 N·m), coat terminals with Battery Terminal Protector Spray to prevent future corrosion. **See preceding WARNINGS and following CAUTION.**

## **⚠ CAUTION**

- **If battery wire terminals are damaged or corroded, replace or clean them as necessary. Failure to do so may cause them to overheat during operation and could result in a fire, property damage, or personal injury.**
2. The battery should be kept clean and dry to prevent self-discharge. Any dirt, grime or acid spillage should be removed. Wash the battery with a bristle brush using water and bicarbonate of soda (1 cup (237 mL) baking soda per 1 gallon (3.8 L) of water). Rinse with water. Do not allow solution to enter battery through the vent cap holes.
  3. Check battery periodically to see that it is in a full state of charge.
  4. Keep battery hold-down clamp tight.

## **SELF-DISCHARGE**

Dirt and battery acid can provide a path for a small current draw that slowly discharges the battery. To prevent self-discharge, the battery should always be kept clean.

Hot weather also has an effect on a battery's self-discharge rate. The higher the temperature, the quicker a battery will discharge. In hotter climates, therefore, the battery should be checked more often. When storing the battery, keep in a cool place.

## VIBRATION DAMAGE

The battery hold-down clamp should always be tight enough to keep the battery from bouncing. Battery life may be severely shortened if the clamp is too loose. Excessive vibration shortens the life of the battery. It may also cause acid to leak out of the vent caps and corrosion to build up on surrounding metal parts. The acid that is lost reduces the capacity of the battery and cannot be replaced.

## BATTERY REMOVAL

See General Warnings on page 1-1. Also see **DANGER** at beginning of Battery topic.

1. Turn the key switch OFF and remove the key. Place the Forward/Neutral/Reverse control (FNR) in the NEUTRAL position. Chock the wheels.
2. Disconnect the battery and spark plug wire.
3. Remove the battery hold-down clamp from the battery.
4. Lift the battery from the vehicle. **See following WARNING.**

### **▲ WARNING**

- **Keep the battery in an upright position to prevent electrolyte leakage. Tipping the battery beyond a 45° angle in any direction can allow a small amount of electrolyte to leak out of the vent hole. Do not exceed this 45° angle when lifting, carrying or installing battery. The battery acid could cause severe personal injury when accidentally coming in contact with the skin or eyes, and could damage clothing.**

## CHARGING THE BATTERY

See General Warnings on page 1-1. Also see **DANGER** at beginning of Battery topic.

1. Charge the battery using an automotive type 12-volt battery charger. Follow all warnings and procedures supplied by the battery charger manufacturer.
2. Attach the positive (+) charger cable to the positive (+) battery post.
3. Attach the negative (–) charger cable to the negative (–) battery post.
4. The battery may be charged with a slow charge (3 to 10 amps) or a fast charge (20 to 30 amps). Charge until the battery voltage is greater than 12.4 volts. **See following WARNING.**

### **▲ WARNING**

- **If the battery case feels hot (approximately 125 °F (52 °C) or more), emits gases, or fluid boils from vents, stop charging immediately. Failure to stop charging battery when any of these conditions are present could result in an explosion, personal injury and/or damage to the battery.**
- **Do not disconnect the charger DC leads from the battery when the charger is on. The resulting arcing between the DC leads and battery post could cause an explosion.**
- **If the charger must be stopped, disconnect the AC supply cord from the wall outlet before disconnecting the DC leads from the battery. Allow the battery to cool to room temperature and resume charging battery at a lower amp rate.**

## BATTERY INSTALLATION

See General Warnings on page 1-1. Also see **DANGER** at beginning of Battery topic.

1. Place the battery into the vehicle with the battery posts facing the engine.
2. Secure the battery to the vehicle with the clamp and install bolt, washer and locknut and tighten to 144 in·lb (16.3 N·m). A loose battery clamp may allow the battery to become damaged from vibration or jarring.

3. Connect the battery and spark plug wire.

## BATTERY STORAGE

See General Warnings on page 1-1. Also see DANGER at beginning of Battery topic.

1. Keep the battery clean and free of corrosion.
2. The battery cables should be disconnected from the battery so the battery can be connected to the charger. The battery can be left in the vehicle. Disconnect the negative (-) cable first.
3. Fully charge the battery prior to storage.
4. Store in a cool, dry area. The colder the area in which the battery is stored, the less the battery will self-discharge. A battery stored at 0 °F (-17.8 °C) will discharge very little over a four-month period. A battery stored at 80 °F (27 °C) will have to be recharged every few weeks.
5. Check the state of charge periodically. A battery that is discharged and left in a cold environment can freeze and crack. If the voltage drops below 12.4 volts, the battery should be recharged. **See following WARNING.**

### **⚠ WARNING**

- If the battery is frozen or the container is bulged, discard battery. A frozen battery can explode.
6. The frequency of recharging required depends on the temperature of the storage area, but it is recommended that the battery be monitored for state of charge every month. Also, if the storage area is unheated in a cold climate and recharging is required, it is recommended that the area be heated to at least 60 °F (16 °C) prior to charging. The battery will not charge effectively in cold temperatures for the same reasons that it does not discharge as rapidly in cold temperatures.

## CHARGING A DEAD BATTERY

See General Warnings on page 1-1. Also see DANGER at beginning of Battery topic.

The vehicle is equipped with a starter/generator. The generator is not designed to charge a dead battery. If the vehicle battery has become discharged, it must be charged using a properly rated automotive type charger. **See following WARNING.**

### **⚠ WARNING**

- Do not jump-start a dead battery using another battery and jumper cables.

## OXYGEN SENSOR

### OXYGEN SENSOR REMOVAL

1. Disconnect the battery.
2. Disconnect the oxygen sensor connector from the engine wire harness (1) (**Figure 12-50, Page 12-46**).

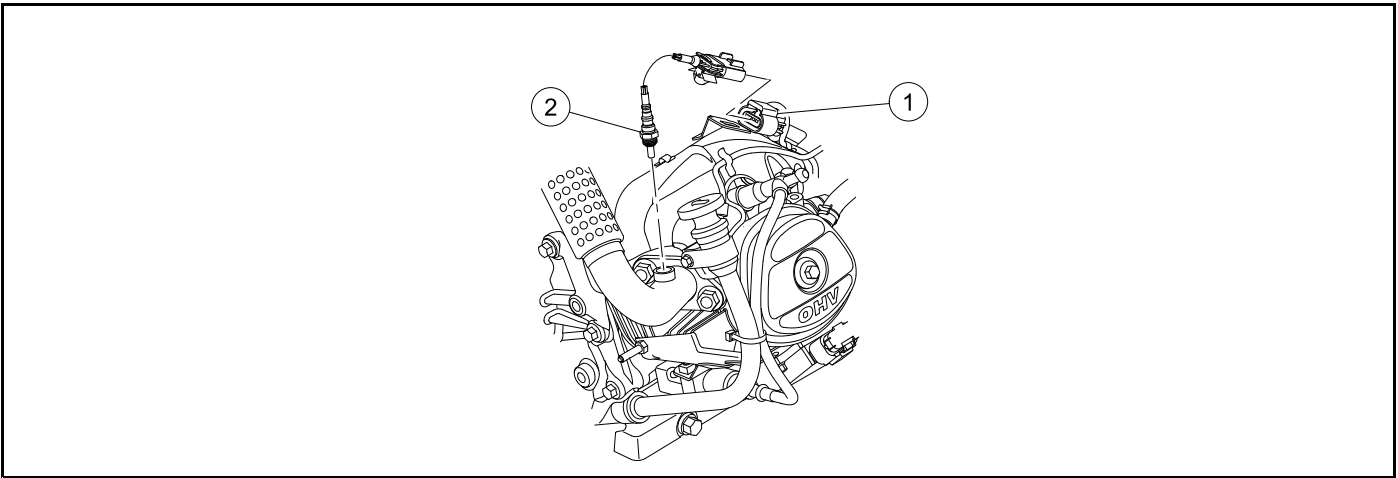

**Figure 12-50 Oxygen Sensor**

3. Remove the oxygen sensor (2).

### OXYGEN SENSOR INSTALLATION

1. Install the oxygen sensor (2) into the muffler tube (**Figure 12-50, Page 12-46**). Tighten the oxygen sensor to 13.25 ft·lb (18 N·m).
2. Connect the oxygen sensor connector to the engine wire harness (1).
3. Connect the battery.

## GROUND CABLES

**NOTE:** Verify that all cables (fuel tank, engine, battery, starter/generator and voltage regulator) are connected securely.

### **⚠ DANGER**

- See General Warnings on page 1-1.

### **⚠ WARNING**

- See General Warnings on page 1-1.

## **GENERAL INFORMATION**

---

See General Warnings on page 1-1.

This vehicle is powered by a Kohler, high-compression, chain driven, overhead valve engine (OHV). **See following NOTE.**

***NOTE:** Engine rotation is counterclockwise as viewed from the clutch side of the engine.*

This section contains information for removing and replacing the engine and snubber.

**See Kohler Engine Service Manual for complete disassembly, rebuild, and repair information.**

### **BEFORE SERVICING**

Carefully read the applicable information and instructions before beginning engine service. Diagrams, DANGER, WARNING, CAUTION and NOTE statements and detailed descriptions have been included wherever necessary. Anyone attempting engine service should have knowledge and experience in small engine service and repair.

## ENGINE REMOVAL

See General Warnings on page 1-1.

### **⚠ CAUTION**

- Before removal and disassembly, clean the engine.

1. Disconnect the battery.
2. Disconnect the spark plug wire.
3. For some vehicles, the engine can be removed by lifting it up and out of the chassis. For other vehicles, it is easier to remove the entire powertrain assembly first. If removing the powertrain, see Transaxle Removal.
4. Loosen the clamp and disconnect the air intake hose from the engine.
5. Disconnect the fuel line. See Fuel Line Removal.
6. Remove the screw (1) (Figure 13-1, Page 13-2)

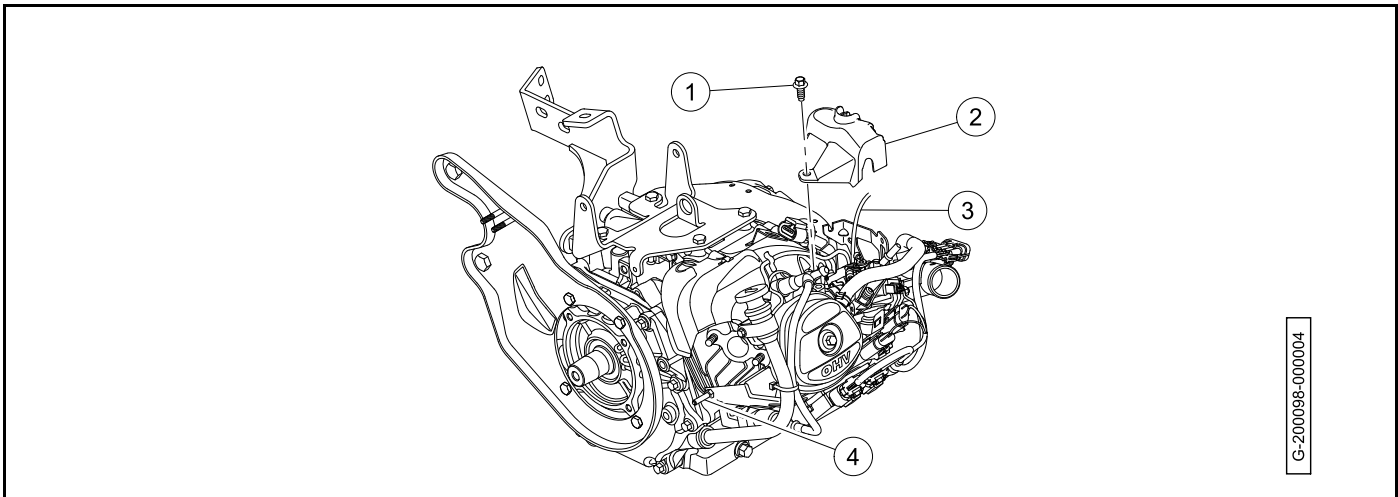

Figure 13-1 Throttle Cover and Ground Cable Removal

7. Remove the throttle body cover (2).
8. Loosen the clamp and disconnect the vent line (3).
9. Disconnect the engine wire harness from the main harness.
10. Remove the governor cable. See Governor Cable Removal.
11. Remove the accelerator cable. See Accelerator Cable Removal.
12. Disconnect the ground cable from the engine (4).
13. Remove the starter/generator and belt. See Starter/Generator Removal.
14. Remove the drive clutch. See Drive Clutch Removal.
15. Remove the muffler. See Muffler Removal.

16. Remove the bolts (5 and 6) (Figure 13-2, Page 13-3).

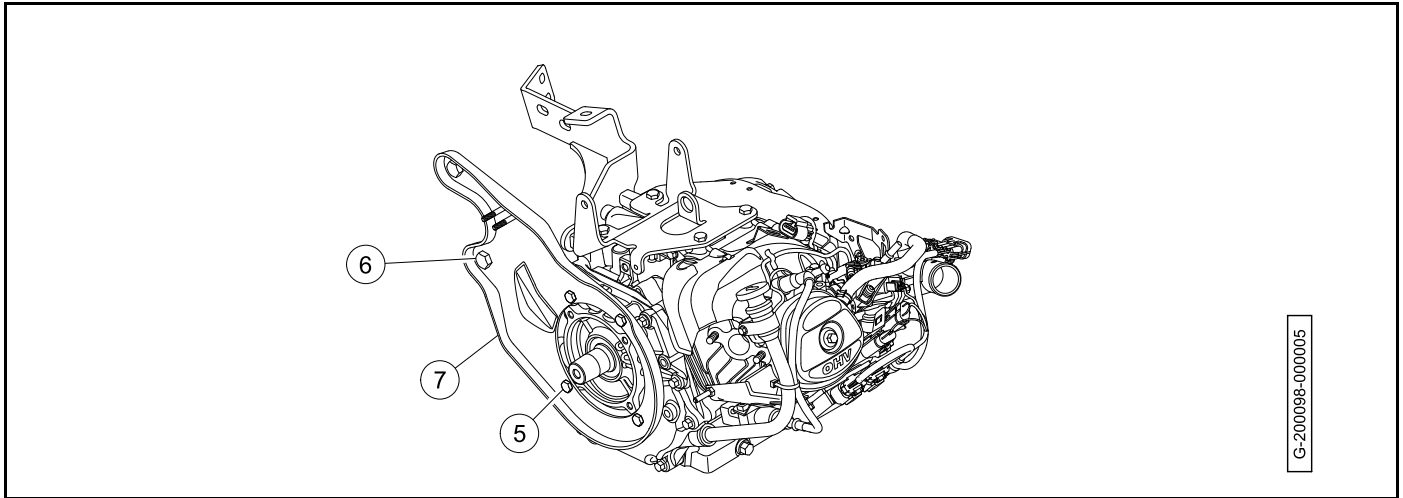

Figure 13-2 Clutch Plate Removal

17. Remove the clutch plate (7).  
18. Remove the bolts (8) (Figure 13-3, Page 13-3).

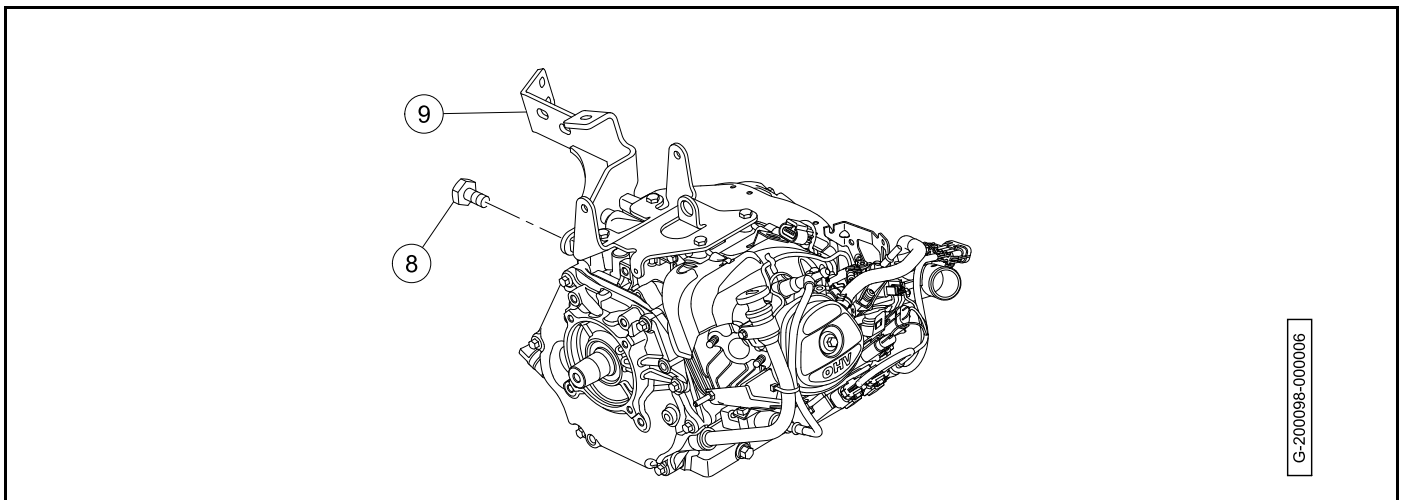

Figure 13-3 Exhaust Weldment Removal

19. Remove the exhaust weldment (9).

20. Remove the bolts (10), washers (11), and nuts (12) (Figure 13-4, Page 13-4).

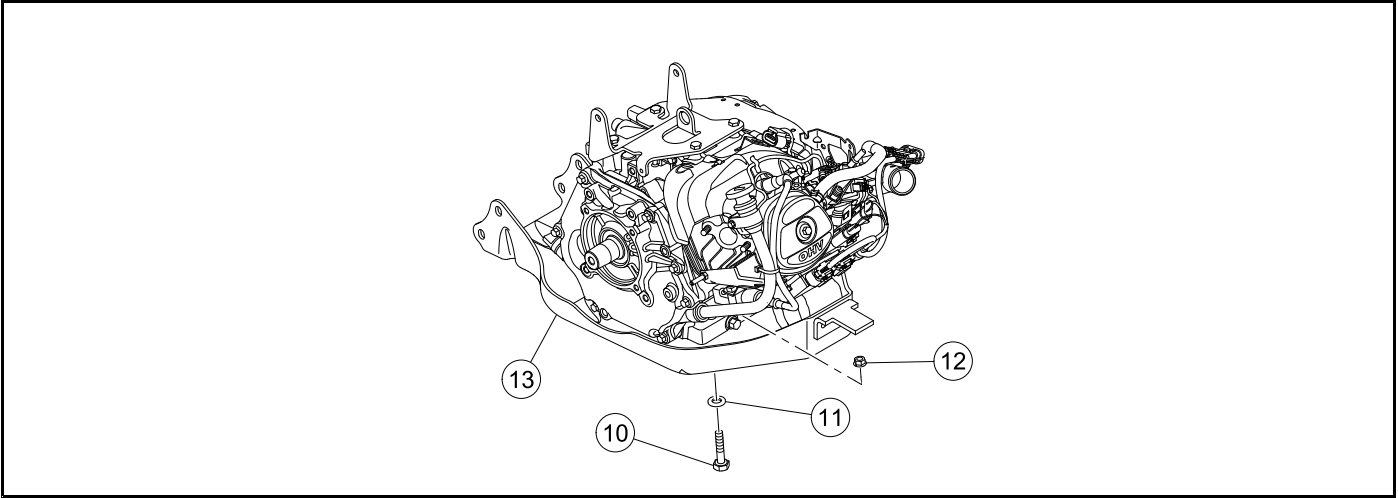

Figure 13-4 Engine Pan Removal

21. Lift the engine from engine pan (13). **See following NOTE.**

**NOTE:** The engine weighs approximately 54 lb (24.5 kg).

22. Remove the oil drain plug and drain all oil from crankcase. Dispose of engine oil properly.
23. If replacing the engine, remove the starter/generator mounting weldment and retain for installation on new engine. **See following NOTE.**



## ENGINE INSTALLATION

See General Warnings on page 1-1.

1. If replacing engine, install starter/generator mounting weldment on engine with the screws. Tighten the screws to 17 ft·lb (23 N·m).
2. Install oil drain plug and tighten to 13 ft·lb (18 N·m).
3. Place the engine onto the engine pan (13) and secure with mounting hardware (10, 11, and 12) (**Figure 13-5, Page 13-5**). Tighten the nuts to 33 ft·lb (40.6 N·m).

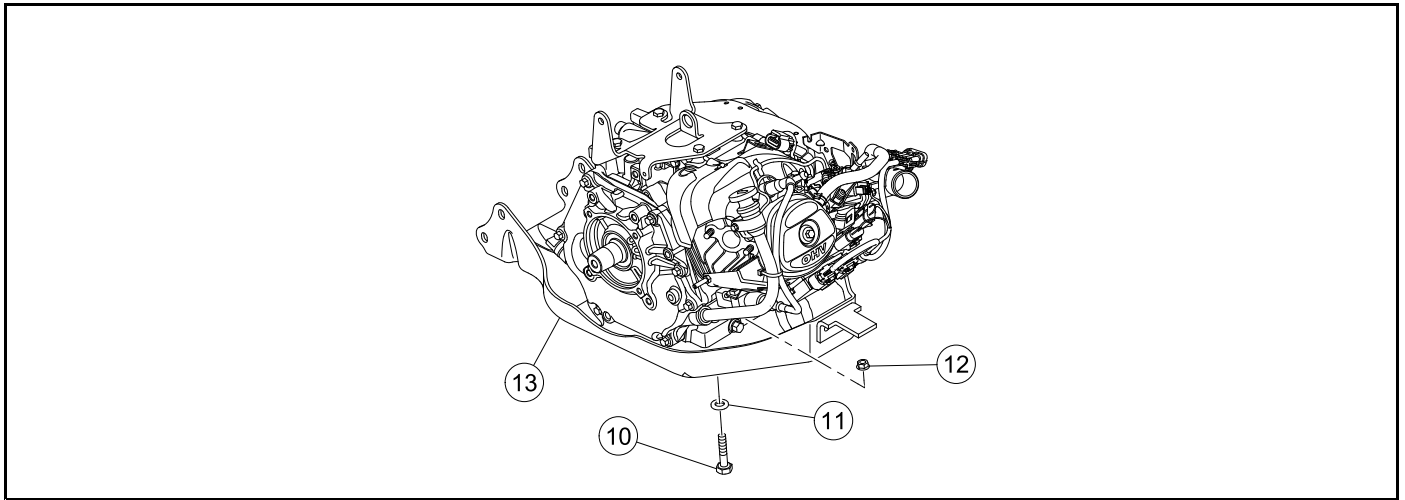

**Figure 13-5 Engine Pan Installation**

4. Install the muffler weldment (9) with the bolts (8) (**Figure 13-6, Page 13-5**). Tighten the bolts to 18 ft·lb (24 N·m).

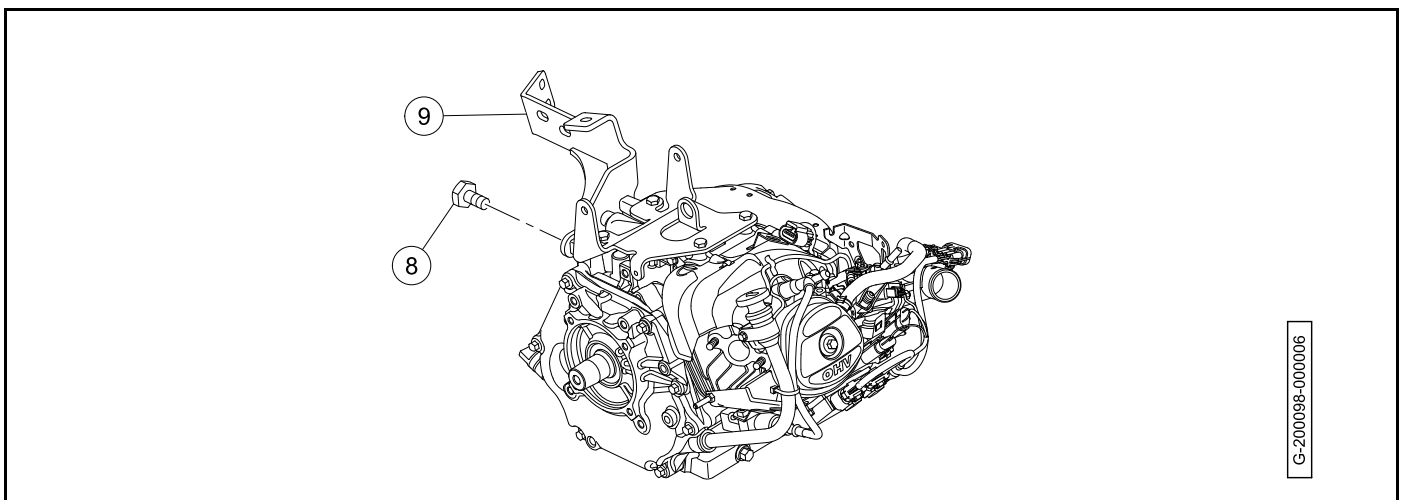

**Figure 13-6 Exhaust Weldment Installation**

5. Install the clutch plate (7) with bolts (5 and 6) (**Figure 13-7, Page 13-6**). Tighten the bolts (5) to 27 ft·lb (36 N·m). Tighten the bolts (6) to 50 ft·lb (68 N·m).

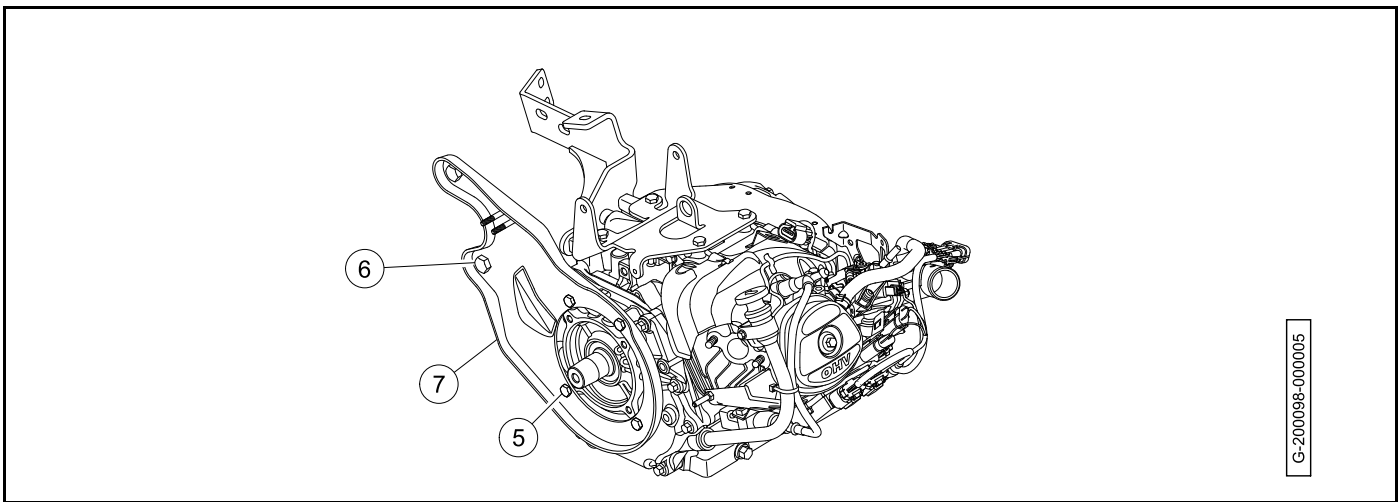

**Figure 13-7 Clutch Plate Installation**

6. Install the drive clutch. See Drive Clutch Installation.
7. Install the muffler. See Muffler Installation.
8. Install the starter/generator and belt. See Starter/Generator Installation.
9. If necessary, install the powertrain. See Transaxle Installation.
10. Install the governor cable. See Governor Cable Installation and Adjustment.
11. Install the accelerator cable. See Accelerator Cable Installation and Adjustment.
12. Secure the accelerator cable and governor cable P-clamps to engine. Tighten the P-clamp bolts to 36 in·lb (4.0 N·m).
13. Connect the air intake hose. See Air Cleaner Installation.
14. Install the fuel line. See Fuel Line Installation.
15. Connect the engine wire harness to the main wire harness.

16. Connect the ground cable to the engine (4) (**Figure 13-8, Page 13-7**).

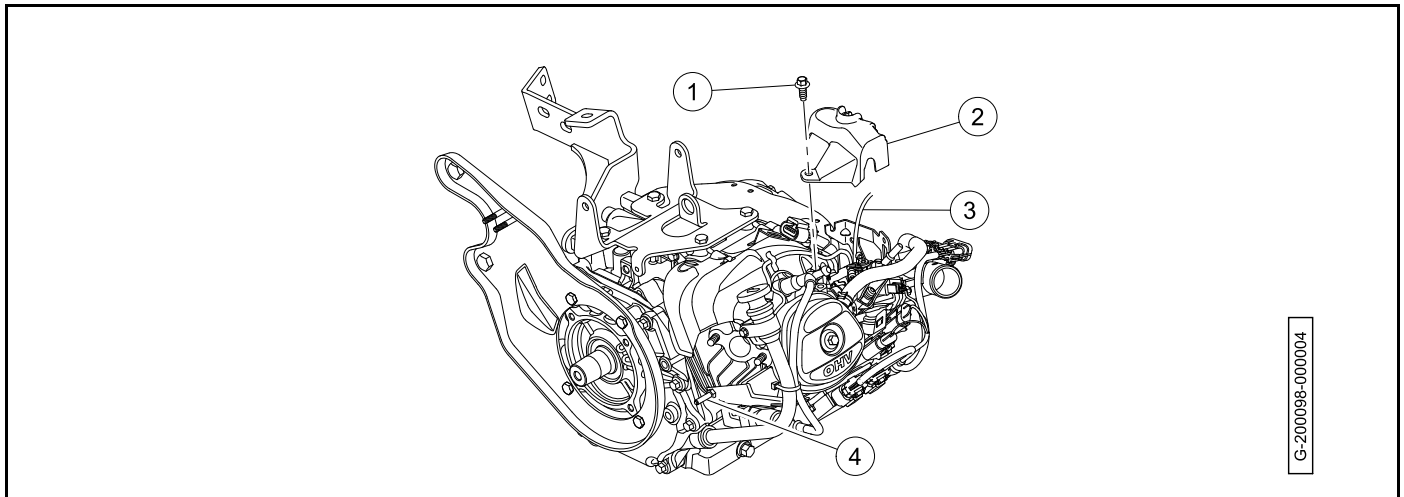

**Figure 13-8 Throttle Cover and Ground Cable Installation**

17. Route the vent line (3) through the throttle body cover (2).
18. Connect the vent line.
19. Install the throttle body cover with the screw (1). Tighten the screw to 36 in·lb (4.0 N·m).
20. Check all hardware for proper torque/tightness.
21. Fill engine to proper level with correct type of oil. See Vehicle Specifications.

### **⚠ CAUTION**

- **Do not overfill with oil.**

22. Connect the battery and spark plug wire.
23. Adjust the idle. See **ECU Reset Procedure** and **TPS Learn Procedure for Pedal Start Applications** in the Kohler Service Manual.
24. Adjust the engine RPM setting. See Engine RPM Adjustment.
25. Test-drive vehicle to ensure all systems are functional and correctly adjusted.

## SNUBBER

See General Warnings on page 1-1.

**NOTE:** The snubber is installed on the gasoline vehicle only.

### SNUBBER REMOVAL

1. Support the powertrain with a floor jack under the engine pan (1) so that the snubber (2) is raised slightly and does not rest on the vehicle frame (**Figure 13-9, Page 13-8**).
2. Remove the two bolts (3) and two lock nuts (4) securing the snubber bracket (5) to the engine pan.
3. Slide the snubber and snubber bracket assembly toward the battery to remove it from vehicle.
4. Slide the snubber off the snubber bracket.

### SNUBBER INSTALLATION

1. Slide the snubber (2) onto the snubber bracket (5) (**Figure 13-9, Page 13-8**).
2. Install the snubber bracket and snubber assembly onto engine pan (1).
3. Install the bolts (3) and lock nuts (4). Tighten the lock nuts (4) from 20 to 25 ft·lb (27.1 to 33.9 N·m).

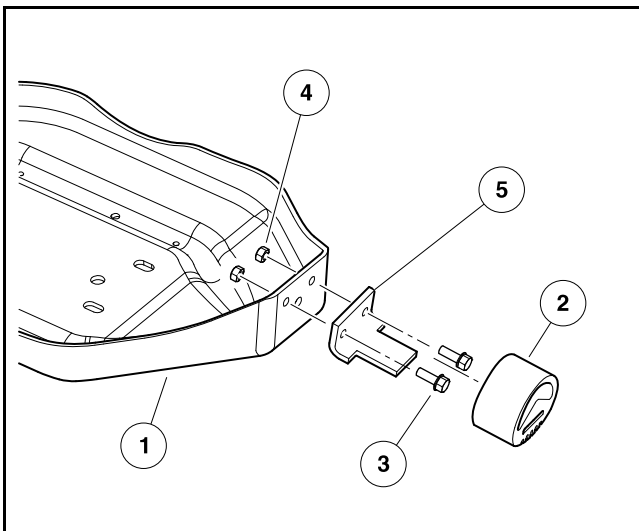

3039C

Figure 13-9 Snubber

### **⚠ DANGER**

- See General Warnings on page 1-1.

### **⚠ WARNING**

- See General Warnings on page 1-1.
- Fuel may be under pressure. Use extreme caution when disconnecting fuel line to prevent the spray of fuel onto hot engine. See Relieving Fuel Pressure.

## GENERAL INFORMATION

---

The engine is equipped with a throttle body/fuel injector assembly that is controlled by an ECU and requires no adjustment. The ECU monitors engine conditions through inputs from a Manifold Absolute Pressure (MAP) sensor, engine block temperature sensor and ignition timing.

### EFI SYSTEM FEATURES/SPECIFICATIONS

- The fuel pump operating pressure is 50 psi +/- 3. The Kohler fuel pressure gauge has a psi variance of +/- 3.
- Fuel pump operates for a few seconds when key switch is turned to the ON position; it stops if no engine RPM is detected by the ECU
- The ECU indicates a fault code through the malfunction indicator light (MIL)
- In-tank fuel pump
- Return-less system
- High fuel pressure system
- Controls fuel pump, fuel injector, and oil lamp
- Automatic altitude compensation
- Closed-loop system (includes oxygen sensor)
- Separate EFI wire harness
- Fail-safe function

## ENGINE CONTROL LINKAGES

---

See General Warnings on page 1-1.

## **⚠ DANGER**

- To ensure the vehicle does not run over you while you disconnect or adjust the accelerator push rod, do the following:
  - Turn key switch OFF and remove key, place Forward/Reverse handle in the NEUTRAL position, and chock the wheels prior to servicing the vehicle.
  - Disconnect battery cables, negative (-) cable first.
  - Disconnect the spark plug wire from the spark plug.
  - See Disconnecting the Battery-Gasoline Vehicles on page 1-3.

## **GENERAL INFORMATION**

For proper vehicle operation, it is important the accelerator pedal, governor linkage, and throttle adjustments are done correctly and in the proper sequence. **See following CAUTION.**

## **⚠ CAUTION**

- Improper adjustment can result in poor vehicle performance and/or damage to the engine components.

## **GROUND SPEED**

*NOTE: If possible, the manufacturer recommends measuring ground speed when setting engine RPM.*

This vehicle should reach the forward ground speed specified in the Vehicle Specifications Section.

## **ACCELERATOR ROD**

### **Accelerator Rod Removal**

1. Raise the front of the vehicle. Place chocks at the rear wheels and lift the front of the vehicle with a chain hoist or floor jack. Place jack stands under the round frame cross tube to support the vehicle. **See preceding DANGER. See also WARNING “Lift only one end of the vehicle...” in General Warnings on page 1-1.**
2. Remove the accelerator rod by disconnecting the ball joint (1) from the ball stud (2) on the accelerator pedal (**Figure 14-1, Page 14-3**) and from the bell crank at the electrical box (**Figure 14-2, Page 14-3**).

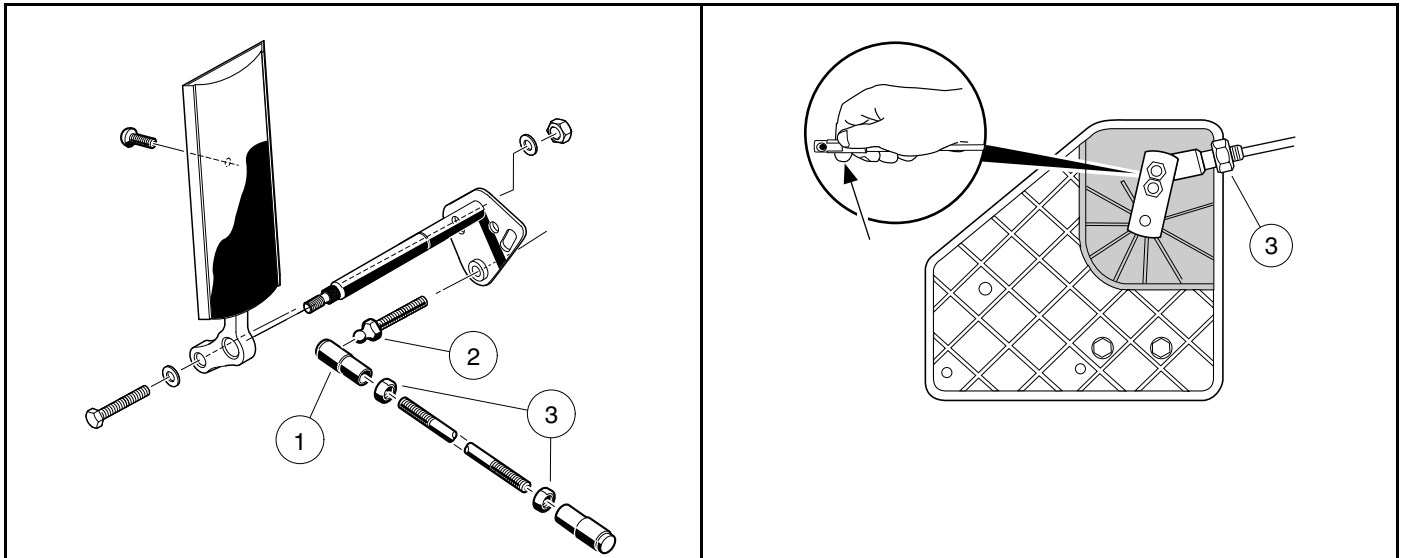

539

Figure 14-1 Accelerator Rod

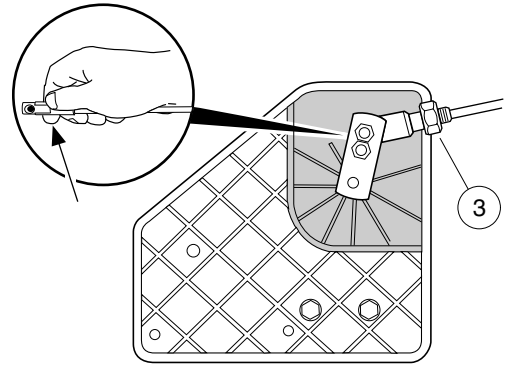

1345

Figure 14-2 Accelerator Rod – Pull Spring Release to Attach (Bottom View)

### Accelerator Rod Installation and Adjustment

1. Before installing the accelerator rod, adjust accelerator pedal position. **See Pedal Group Adjustment – Gasoline Vehicles in the Accelerator and Brake Pedal Group Section.**
2. Install the ball joint (1) on the ball stud (2) at the accelerator pedal (**Figure 14-1, Page 14-3**).
3. Access the engine compartment.
4. Remove the electrical component box screw and cover (**Figure 14-3, Page 14-4**).
5. Adjust length of accelerator rod. With the ball joint jam nuts (3) loose (**Figure 14-1, Page 14-3**), adjust the length of the rod to obtain an accelerator cable cam position of  $7^\circ$  as shown (**Figure 14-3, Page 14-4**). **See following CAUTION.**

### **⚠ CAUTION**

- Be sure that approximately an equal number of threads are exposed at each end of the accelerator rod.
6. Install the accelerator rod on the bell crank ball joint on the electrical component box (**Figure 14-2, Page 14-3**). **See following CAUTION.**

### **⚠ CAUTION**

- Inspect the limit switches inside the electrical component box. If a limit switch lever is bent, replace the switch.

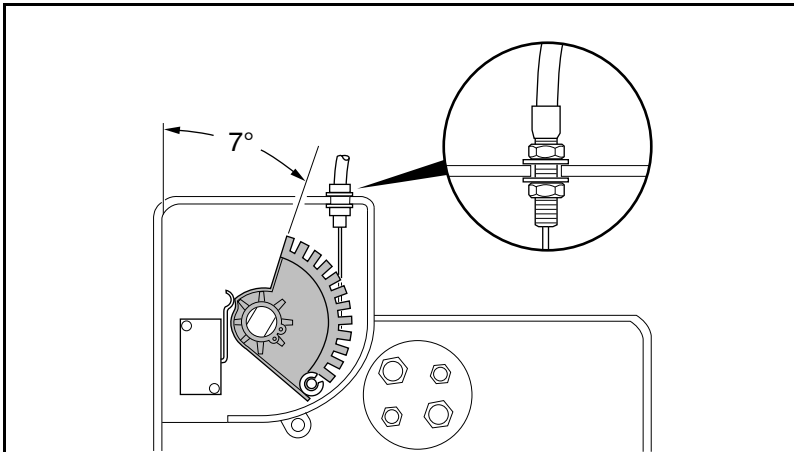

3113

**Figure 14-3 Accelerator Cable Cam Position – 7° (Top View)**

7. Before tightening the jam nuts (3), set the park brake to the first latch and pawl position and check for proper activation of switches.
8. While pressing the accelerator pedal, the following events should occur in exactly the order shown:

**NOTE:** Always perform a visual check to ensure the starter motor begins rotating the engine prior to the throttle body lever moving.

EVENT	APPROXIMATE PEDAL TRAVEL
Park brake release	0° to 4°
Solenoid activation and engine start	4° to 15°
Throttle body actuation	15° and greater

9. While holding the accelerator ball joint with pliers, tighten the jam nuts against the ball joints, accelerator ball joint first, at each end of the accelerator rod.
10. Check rod adjustment for proper switch activation.
11. After the pedal group and accelerator rod are properly adjusted, adjust the engine RPM setting. **See Engine RPM Adjustment on page 14-10.**
12. Install the electrical component box cover and tighten retaining screw to 18 in·lb (2.0 N·m).
13. Connect battery and spark plug wire. **See Connecting the Battery-Gasoline Vehicles on page 1-3.**



## GOVERNOR CABLE

### Governor Cable Removal

1. Turn the key switch to the OFF position and remove the key, place the Forward/Neutral/Reverse control (FNR) in the NEUTRAL position, and chock the wheels.
2. Disconnect battery and spark plug wire.
3. At engine:
  - 3.1. If equipped, remove air deflector from top of engine.
  - 3.2. Remove the governor cable fitting (1) from the linkage retainer (2) (**Figure 14-4, Page 14-5**).

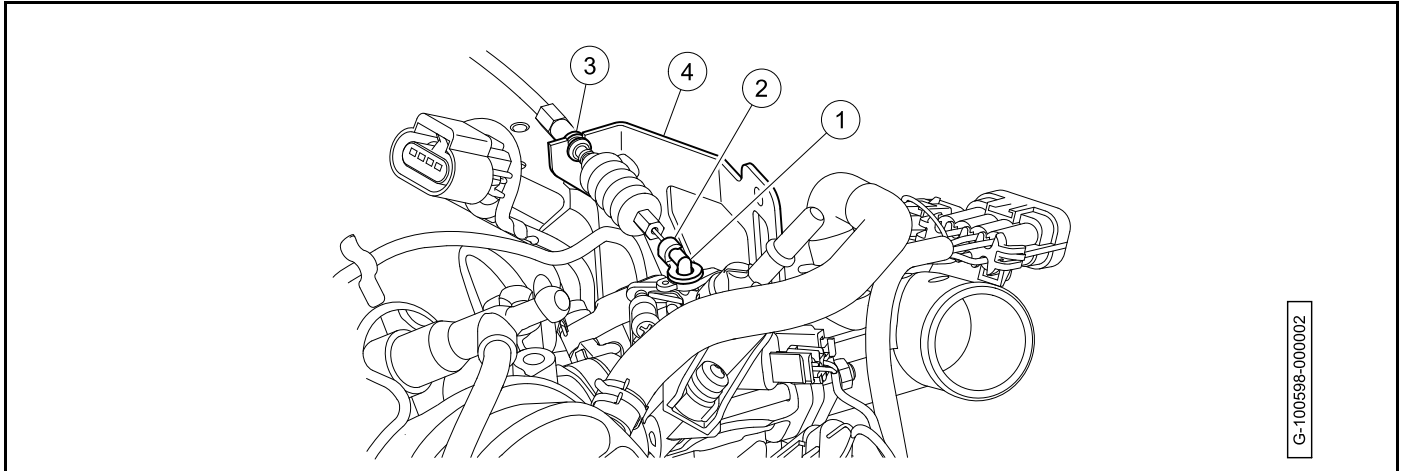

**Figure 14-4 Governor Cable Removal - Throttle Body**

- 3.3. Disconnect the governor cable fitting from throttle lever (3).
- 3.4. Unsnap governor cable from throttle body bracket (4).
4. At transaxle:
  - 4.1. Disconnect "Z" fitting of governor cable (1) from governor arm (2) (**Figure 14-5, Page 14-5**).

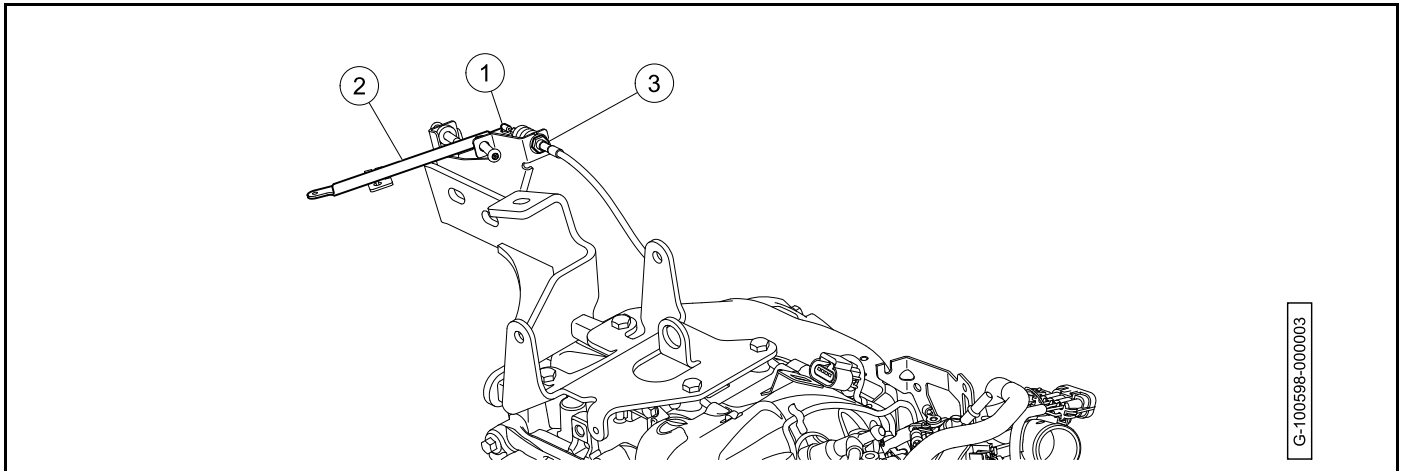

**Figure 14-5 Governor Cable Removal - Governor Arm**

- 4.2. Loosen jam nuts at governor bracket (3) and remove the governor cable from vehicle.

### Governor Cable Installation and Adjustment

1. At engine:

- 1.1. Snap governor cable into throttle body bracket (4) (Figure 14-6, Page 14-6).

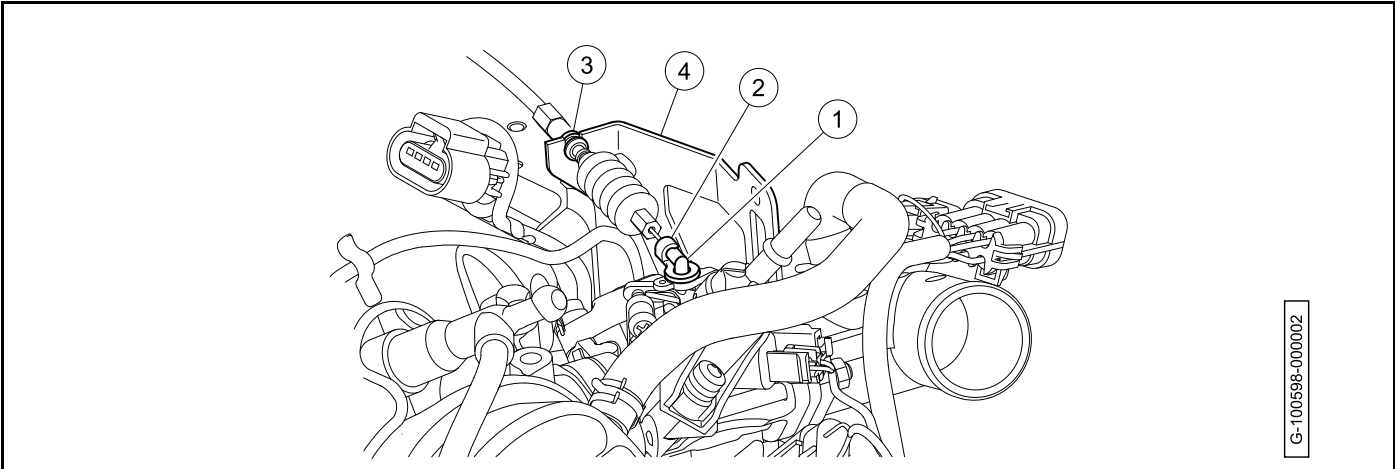

**Figure 14-6 Governor Cable Installation - Throttle Body**

1.2. Connect the governor cable fitting (1) to throttle lever (2).

1.3. Install the governor cable fitting into the linkage retainer (3).

2. At transaxle:

- 2.1. Slide bellows off threaded end of cable housing, separate jam nuts and place threaded end into governor bracket (3) (Figure 14-7, Page 14-6).

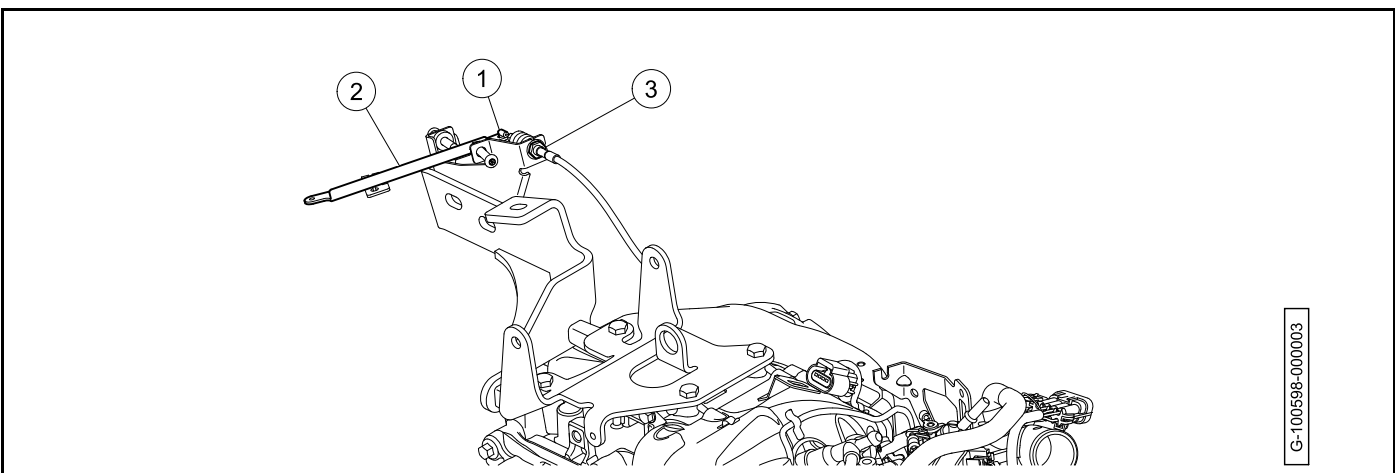

**Figure 14-7 Governor Cable Installation - Governor Arm**

2.2. Finger-tighten the jam nuts.

2.3. Push bellows back onto threaded end of cable housing.

2.4. Connect "Z" fitting of governor cable (1) to governor arm (2).

- Loosen adjustment screw jam nut (4) and back off throttle stop screw (5) several turns (**Figure 14-8, Page 14-7**).

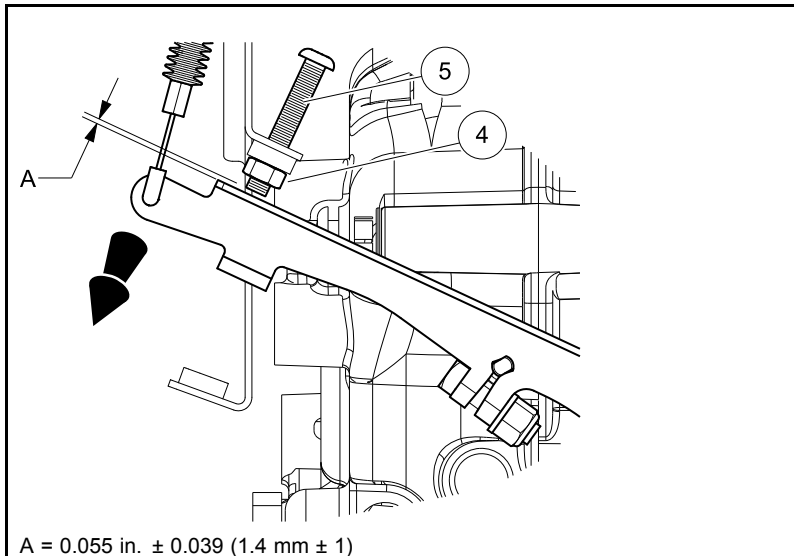

3111B

**Figure 14-8 Throttle Stop Screw Gap**

- Rotate governor arm counterclockwise until it stops and hold in this position.
- Adjust governor cable jam nuts until throttle lever is at “wide open throttle” (WOT) and tighten the governor cable jam nuts to 36 in·lb (4.0 N·m).
- Release governor arm to return to “idle” position.
- Adjust gap (A) between governor arm and throttle stop screw to 0.055 in. ( $\pm$ 0.039) (1.4 mm ( $\pm$ 1)) as shown (**Figure 14-8, Page 14-7**). Tighten stop screw jam nut to 36 in·lb (4.0 N·m).
- Check engine RPM adjustment. See Engine RPM Adjustment.

## ACCELERATOR CABLE

### Accelerator Cable Removal

- Disable the vehicle.
- Disconnect the battery and spark plug wire.

## 3. At transaxle:

- 3.1. Unhook spring fitting of accelerator cable (1) from governor arm (2) (**Figure 14-9, Page 14-8**).

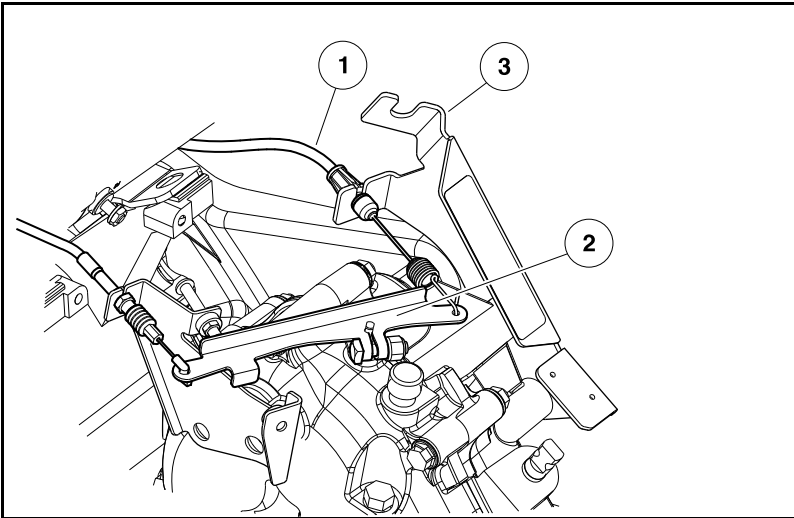

3110D

**Figure 14-9 Accelerator Cable Removal - Governor Arm**

- 3.2. Unsnap accelerator cable from FNR/accelerator cable bracket (3).

## 4. At electrical component box:

- 4.1. Remove electrical component box cover and loosen jam nuts (4) on side of electrical component box (**Figure 14-10, Page 14-8**).

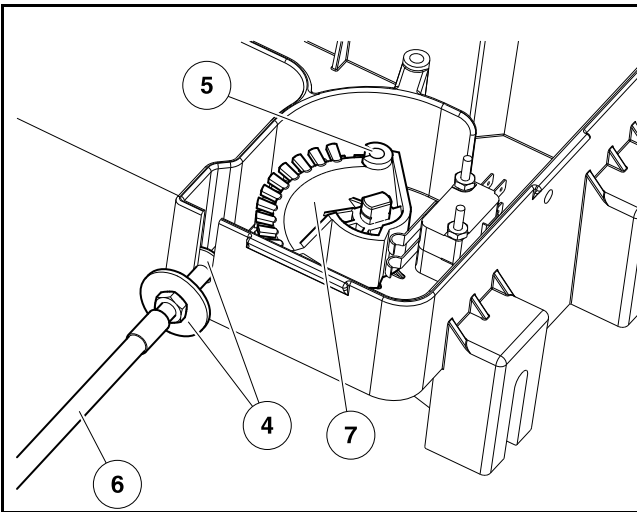

3046B

**Figure 14-10 Accelerator Cable Removal - Electrical Component Box**

- 4.2. Disconnect barrel fitting (5) of accelerator cable (6) from cam (7) in electrical component box and remove accelerator cable from vehicle.

### Accelerator Cable Installation

## 1. At transaxle:

- 1.1. Hook spring fitting of accelerator cable (1) to governor arm (2) (**Figure 14-11, Page 14-9**).

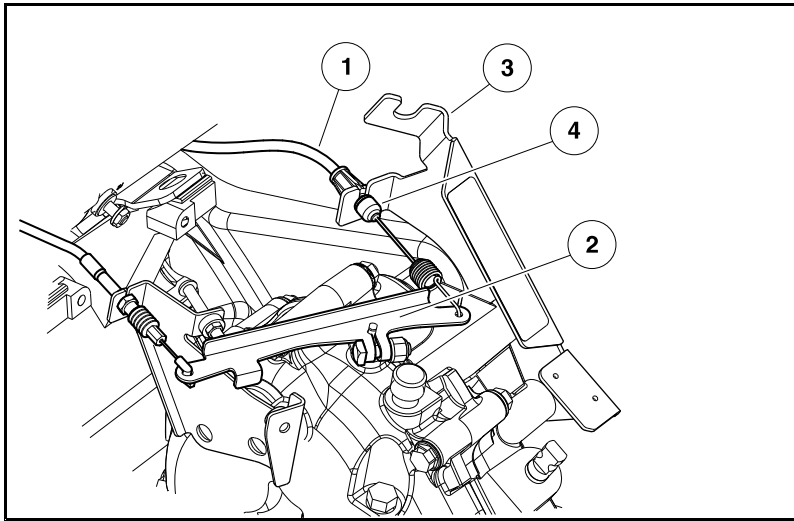

3110C

**Figure 14-11 Accelerator Cable Installation - Governor Arm**

- 1.2. Snap accelerator cable into FNR/accelerator cable bracket (3).
- 1.3. Push dust shield (4) onto end of cable housing.
2. At electrical component box:
  - 2.1. Insert barrel fitting (5) of accelerator cable (6) into cam (7) in electrical component box (**Figure 14-12, Page 14-9**).

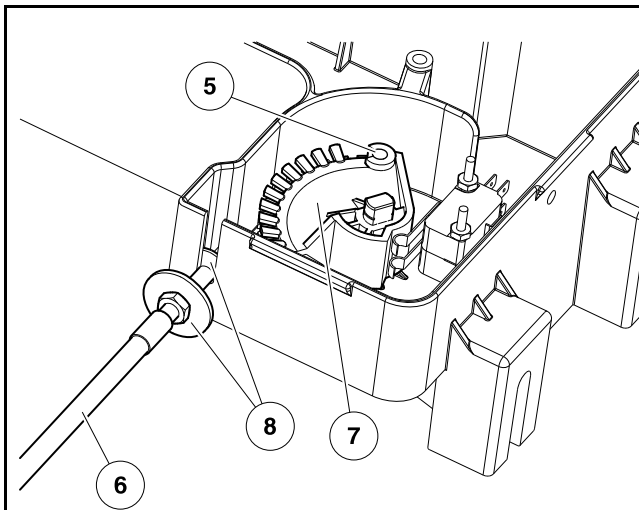

3046C

**Figure 14-12 Accelerator Cable Installation - Electrical Component Box**

- 2.2. Separate jam nuts (8) on cable and place threaded end into slot of electrical component box. Tighten the jam nuts finger-tight.
- 2.3. Before tightening the jam nuts, make sure the engine RPM adjustment is correct. See Engine RPM Adjustment.
- 2.4. Install electrical component box cover and tighten screw to 18 in·lb (2.0 N·m).
3. Connect the battery and spark plug wire.

## CLOSED THROTTLE OR IDLE ADJUSTMENT

To adjust the idle, see **ECU Reset Procedure** and **TPS Learn Procedure for Pedal Start Applications** in the Kohler Service Manual.

## HOW TO MEASURE GROUND SPEED

### Best Method

An easy way to check ground speed is by using a GPS device or smartphone application (app). If these are not available, use the alternate method below.

### Alternate Method (Calculated)

Ground speed is easily determined by a known distance travelled, divided by the amount of time it took to travel that known distance ( $Rate = Distance/Time$ ).

1. Establish a known distance to travel (example: 100 ft. (30.5 m) in a safe location using cones or other type of marker.
2. Drive vehicle and bring to maximum speed before reaching the first cone.
3. Using a stopwatch, record the amount of time it takes to travel from the first cone to the second cone at maximum speed.
4. With distance and time determined, calculate ground speed:
  - 4.1. **Rate in seconds:** Divide distance (100 ft (30.5 m)) by time (5 seconds) = 20 ft/sec (6.1 m/sec).
  - 4.2. **Convert seconds to hour:** Multiply 20 ft/sec (6.1 m/sec) by 3600 (the number of seconds in an hour) = 72000 ft/hour (21960 m/hour)
  - 4.3. **Convert to MPH:** Divide 72000 ft/hour by 5280 (number of ft in 1 mile) = 13.64 miles/hour  
**Convert to KPH:** Move the decimal point over three places; 21960 m/hour = 21.96 km/hour

## ENGINE RPM ADJUSTMENT

### DANGER

- **Do not operate gasoline vehicle in an enclosed area without proper ventilation. The engine produces carbon monoxide, which is an odorless, deadly poison.**

1. If governor is adjusted, go to step 2; otherwise, adjust governor. See Governor Cable Installation and Adjustment.
2. Connect the battery and spark plug wire.
3. Measure vehicle ground speed. See How to Measure Ground Speed.
4. Compare measured ground speed with forward ground speed specified in Vehicle Specifications..
5. If adjustment is necessary, use the following procedures:
  - 5.1. To **reduce** RPM, loosen the accelerator cable jam nut on the outside of the electrical component box and tighten the jam nut on the inside of the box until specified ground speed is reached. See Vehicle Specifications.
  - 5.2. To **increase** RPM, loosen the jam nut inside the electrical component box and tighten the jam nut outside the box until specified ground speed is reached.
  - 5.3. Be sure both jam nuts are locked against the electrical component box and check ground speed again. If ground speed needs to be adjusted, repeat previous step. **See following NOTE.**

**NOTE:** If more adjustment is required than the cable housing will allow, make sure the spring fitting on the other end of the accelerator cable is properly installed. Excessive drive belt and clutch wear can also prevent proper ground speed adjustment. Check them for excessive wear. **Section 16 — Clutches**

# AIR INTAKE SYSTEM

See General Warnings on page 1-1.

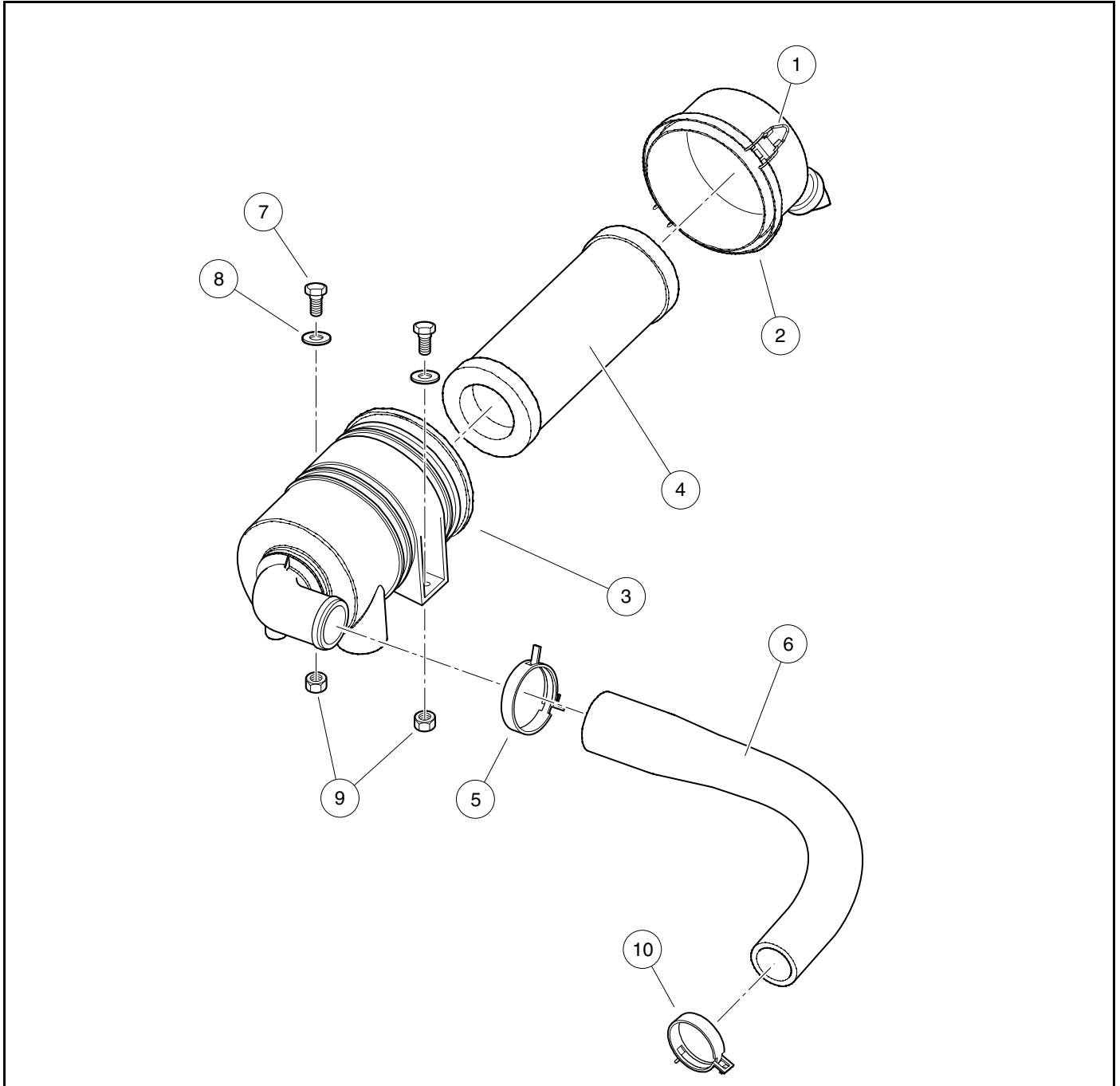

3049

Figure 14-13 Air Intake System

## AIR CLEANER REMOVAL

1. Turn key switch to the OFF position and remove key, place Forward/Neutral/Reverse control (FNR) in the NEUTRAL position, and chock the wheels.
2. Disconnect battery and spark plug wire. **See Disconnecting the Battery-Gasoline Vehicles on page 1-3.**
3. Remove clamp (5) and disconnect air intake hose (6) from air cleaner (3) (**Figure 14-13, Page 14-11**).
4. Remove hardware (7, 8, and 9) securing air cleaner (3) to vehicle.

## AIR CLEANER INSTALLATION

1. Place air cleaner (3) into vehicle and secure with hardware (7, 8, and 9) (**Figure 14-13, Page 14-11**). Tighten locknuts (9) to 85 in·lb (9.5 N·m).
2. Connect air intake hose (6) to air cleaner (3) and secure with clamp (5).
3. Connect battery and spark plug wire. **See Connecting the Battery-Gasoline Vehicles on page 1-3.**



---

## RELIEVING FUEL PRESSURE

---

In the event that servicing the EFI fuel system necessitates removal of the fuel delivery hose, extreme caution must be exercised. The fuel system is under high pressure even with the engine not running. Disconnecting any part of the fuel delivery system, without first depressurizing the system, will result in a sudden release of pressurized gasoline at the connection. To prevent possible serious injury or death, fuel pressure must be relieved before disconnecting or removing the pump, hose and throttle body.

Either of these suggested procedures **MUST** be followed before attempting ANY service work on the EFI fuel system. Following these will relieve any pressure in the fuel hose prior to opening the fuel system.

### TO RELIEVE FUEL PRESSURE

#### Option 1:

1. Turn the key switch to OFF.
2. Disconnect the battery.
3. Wait 15 minutes or more to let the fuel pressure dissipate.

#### Option 2:

1. Turn the key switch to OFF.
2. Disconnect the fuel pump module at the fuel tank.
3. Crank the engine for 5 seconds to start reducing the fuel pressure.
4. Wait for 2-5 seconds.
5. Crank the engine for 5 seconds to let the fuel pressure dissipate.

**NOTE:** To absorb any residual fuel that may be present in the fuel hose, place a rag or towel around the hose at the end being disconnected.

---

## FUEL LINE

---

See General Warnings on page 1-1.

### **WARNING**

- Make sure fuel line is the correct length and properly routed. Failure to heed this warning could result in damage to fuel line and fire.
- Fuel may be under pressure. Use extreme caution when disconnecting fuel line to prevent the spray of fuel onto hot engine. See Relieving Fuel Pressure.

### **CAUTION**

- This EFI gasoline vehicle is equipped with fuel hose rated for high-pressure systems. Always replace the fuel line on this vehicle with approved Club Car replacement part. Do not attempt to repair, patch or splice the fuel line.

The fuel line must be properly routed from the fuel tank to the throttle body. A small, spring steel band clamp is used on the fuel line connection at the throttle body and must be tight. A plastic, dual-locking connector is used at the fuel tank.

**FUEL LINE REMOVAL****⚠ WARNING**

- Fuel may be under pressure. Use extreme caution when disconnecting fuel line to prevent the spray of fuel onto hot engine. See Relieving Fuel Pressure.
- Carefully drain any fuel into an approved container. Add drained fuel back into fuel tank or dispose of properly.

1. Disable the vehicle.

**⚠ WARNING**

- Fuel may be under pressure. Use extreme caution when disconnecting fuel line to prevent the spray of fuel onto hot engine. See Relieving Fuel Pressure.

2. Relieve the fuel pressure.
3. Disconnect the battery.
4. Clean the top of the fuel tank and fuel pump module.
5. At engine:
  - 5.1. Remove the bolt (1) and P-clamp (2) from the fuel line support bracket (3) (**Figure 14-14, Page 14-14**).

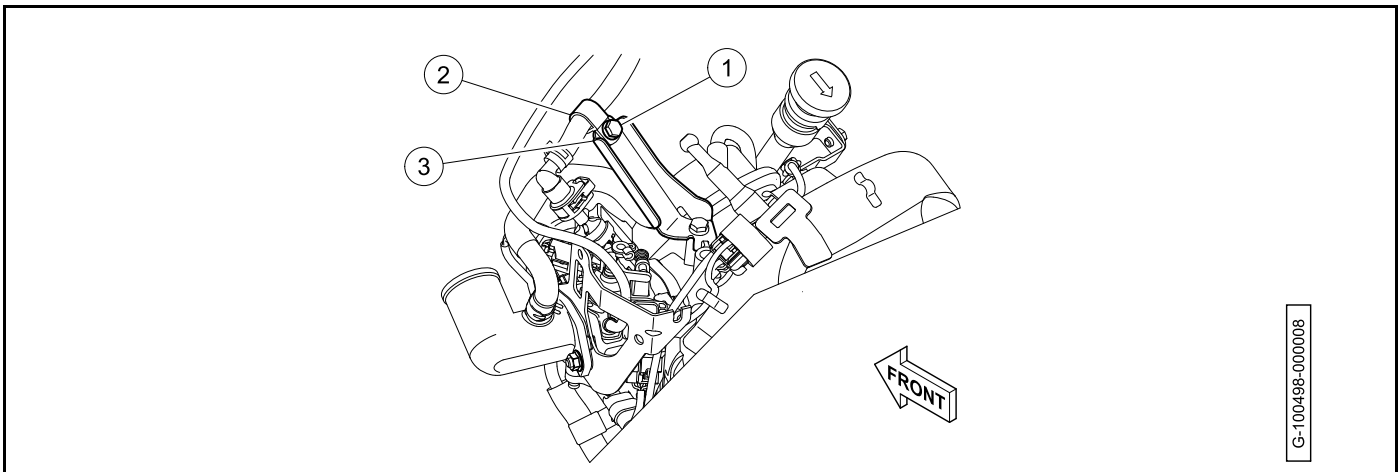

**Figure 14-14 Fuel Line Support Bracket - Disconnect**

- 5.2. Pull out the locking clip (4) (**Figure 14-15, Page 14-15**).

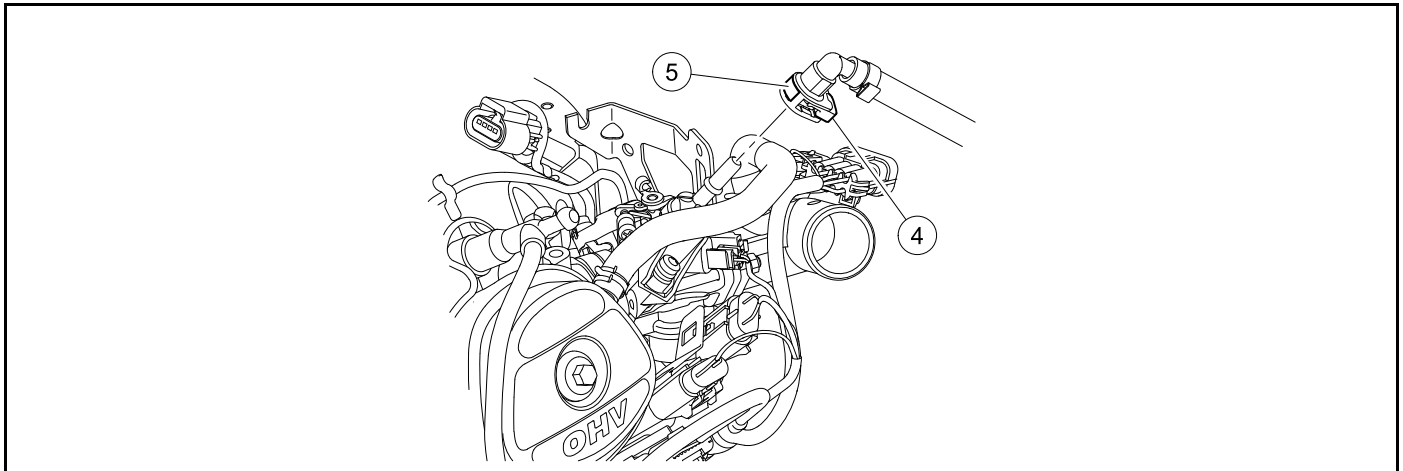

Figure 14-15 Fuel Line Connector – Disconnect

- 5.3. Push in and hold the release tab (5).
- 5.4. Remove the fuel line from the throttle body.
- 5.5. Drain the fuel line into an appropriate container.
6. At fuel tank:
  - 6.1. Pull out the locking clip.
  - 6.2. Push in and hold the release tab.
  - 6.3. Remove the fuel line from fuel tank.

## FUEL LINE INSTALLATION

1. At fuel tank and engine:
  - 1.1.

### **⚠ WARNING**

- **Fuel is flammable. Do not let the fuel line contact the engine or exhaust. Make sure that the fuel line is routed through the fuel line bracket.**
- 1.2. Install the P-clamp (2) and bolt onto the fuel line support bracket (3) (**Figure 14-16, Page 14-16**). Tighten the bolt to 93 to 111 in·lb (10.5 to 12.5 N·m).

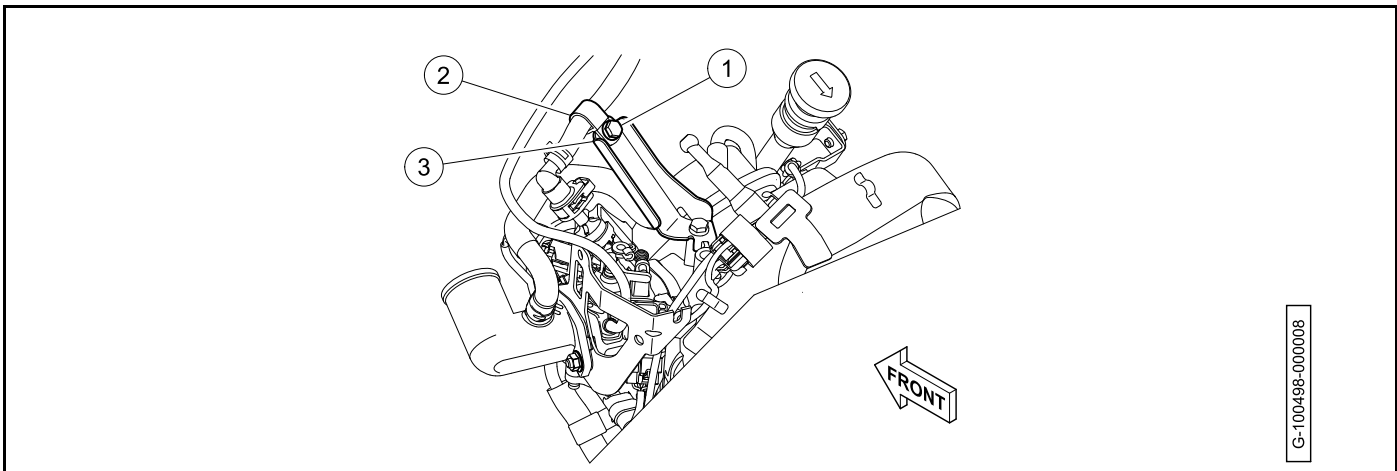

**Figure 14-16 Fuel Line Support Bracket - Connect**

- 1.3. Clean the nipple on top of fuel pump module.
- 1.4. Push the fuel line (5) onto the nipple until it locks into place (**Figure 14-17, Page 14-16**).

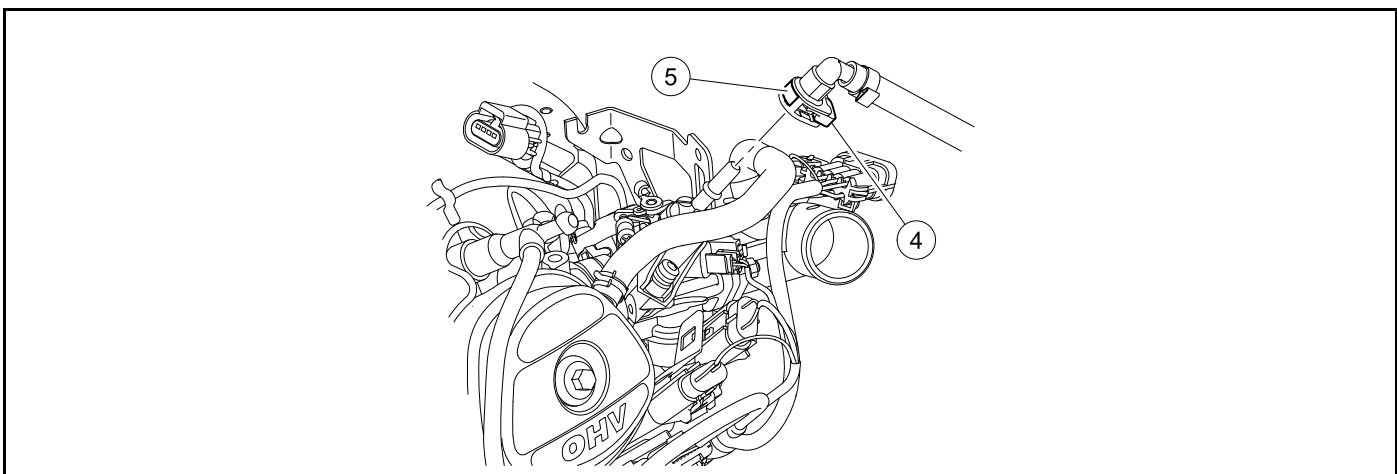

**Figure 14-17 Fuel Line Connector – Connect**

- 1.5. Push in the locking clip (4) until it is fully seated.

## **⚠ DANGER**

- **Ensure line is connected properly to avoid a leak that can cause a fire.**
2. Clean spilled and remove any drained gasoline from the area.
  3. Connect the battery.
  4. Disable the vehicle.
  5. Set the Maintenance/Operate switch to MAINTENANCE.
  6. Turn the key switch to the ON position and check for fuel leaks. Repeat as necessary to build fuel pressure. Any leaks found must be fixed.

## **⚠ DANGER**

- Repair all fuel leaks before returning the vehicle to service.
7. If no leaks are found, set the Maintenance/Operate switch in the OPERATE.

## **FUEL PUMP MODULE**

---

See General Warnings on page 1-1.

### **GENERAL INFORMATION**

**NOTE:** *The fuel pump and fuel level sending unit themselves are not replaceable. If necessary, the fuel pump module must be replaced as an assembly.*

*The fuel pump module can be disassembled to replace the fuel filter.*

The EFI gasoline vehicle is equipped with an electric fuel pump. The fuel pump is protected by a filter and pickup screen.

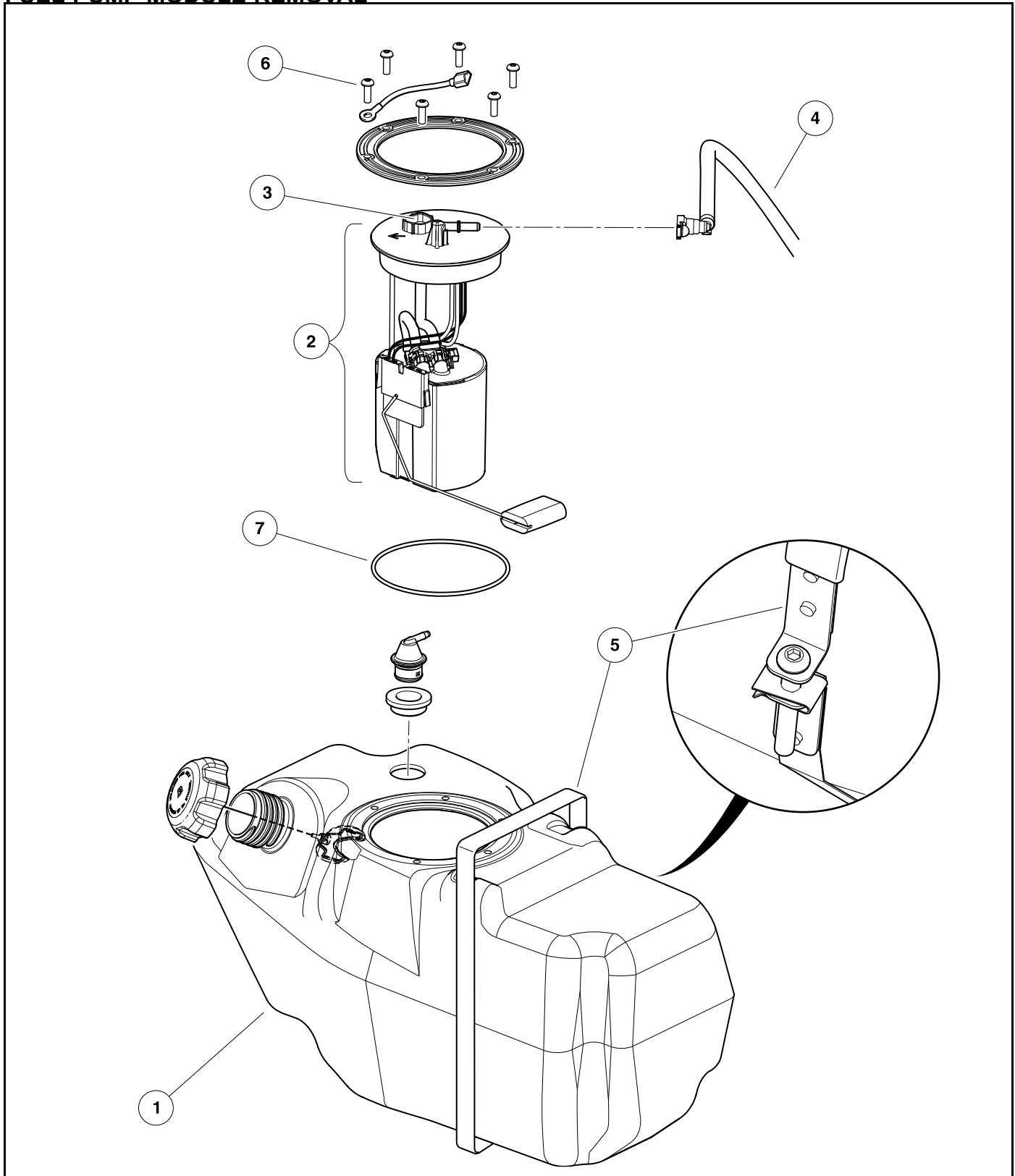
**FUEL PUMP MODULE REMOVAL**

3052B

**Figure 14-18 Fuel Pump Module Removal**

1. Disable the vehicle.
2. Disconnect the battery.
3. Clean the top of the fuel tank (1) and fuel pump module (2) (**Figure 14-18, Page 14-18**).
4. With a marker pen, make a mark across the top of the fuel pump module and onto the tank to note orientation before removal.
5. Disconnect the wire harness plug (3).

### **⚠ WARNING**

- **Fuel may be under pressure. Use extreme caution when disconnecting fuel line to prevent the spray of fuel onto hot engine. See Relieving Fuel Pressure.**
  - **Carefully drain any fuel remaining in the hose or pump module into an approved container. Add drained fuel back into fuel tank or dispose of properly.**
6. Disconnect the fuel line (4) and drain into an appropriate container. See Fuel Line Removal.
  7. Loosen the fuel tank retaining strap (5) to allow tank to move and provide access to all of the fuel pump module hardware (6).
  8. Remove the fuel pump module hardware.
  9. Lift the fuel pump module out of fuel tank and drain into an appropriate container. Discard the fuel module o-ring (7).

**NOTE:** *If equipped with a fuel level sending unit, carefully maneuver module so as to avoid damaging the float arm mechanism.*

### **FUEL PUMP MODULE INSTALLATION**

1. Clean the groove on top of fuel tank.
2. Place new fuel module o-ring (8) into groove on top of fuel tank .
3. Lower fuel pump module (1) into fuel tank noting correct orientation marked before removal. **See following NOTE and CAUTION.**

**NOTE:** *If equipped with a fuel level sending unit, carefully maneuver module so as to avoid damaging the float arm mechanism.*

### **⚠ CAUTION**

- **Ensure o-ring stays seated in place during fuel pump module installation.**
4. Install hold down ring (6) and ground wire (7) with hardware (5) and tighten in a crisscross pattern to 66 in·lb (7.5 N·m). **See following WARNING.**

### **⚠ WARNING**

- **Always install ground wires during reassembly.**
5. Tighten the fuel tank retaining strap screw to 26.5 in·lb (3 N·m).
  6. Connect the fuel line (3) to fuel pump module (1). See Fuel Line Installation. **See following DANGER.**

**⚠ DANGER**

- **Ensure line is connected properly to avoid a leak that can cause a fire.**
7. Connect the wire harness plug (2) to the fuel pump module (1).
  8. Clean spilled fuel. Remove any drained fuel from the area.
  9. Connect the battery.
  10. Disable the vehicle.
  11. Set the Maintenance/Operate switch to MAINTENANCE.
  12. Turn the key switch to ON and check for fuel leaks. Repeat as necessary to build fuel pressure. Any leaks found must be fixed.

**⚠ DANGER**

- **Repair all fuel leaks before returning the vehicle to service.**
13. If no leaks are found, set the Maintenance/Operate switch to OPERATE.

**FUEL TANK**

---

See General Warnings on page 1-1.

**GENERAL INFORMATION**

The vehicle is equipped with a high impact, plastic fuel tank.

**⚠ WARNING**

- **If the fuel tank is damaged, replace it. Do not attempt to repair it. See the following tank removal and disposal procedure.**

**⚠ CAUTION**

- **Add only unleaded fuel to the tank. Do not put oil in the fuel tank.**

**NOTE:** *This gasoline vehicle complies with the California Air Resources Board (CARB) and EPA evaporative emissions regulations when equipped with SAEJ30R9 1/4 in (6.3 mm) fuel vent hose and 3/16 in (4.78 mm) fuel vent hose. To remain in compliance with California and EPA regulations, replace any fuel vent hose on this vehicle with Club Car fuel vent hoses or equivalent.*



FUEL TANK REMOVAL

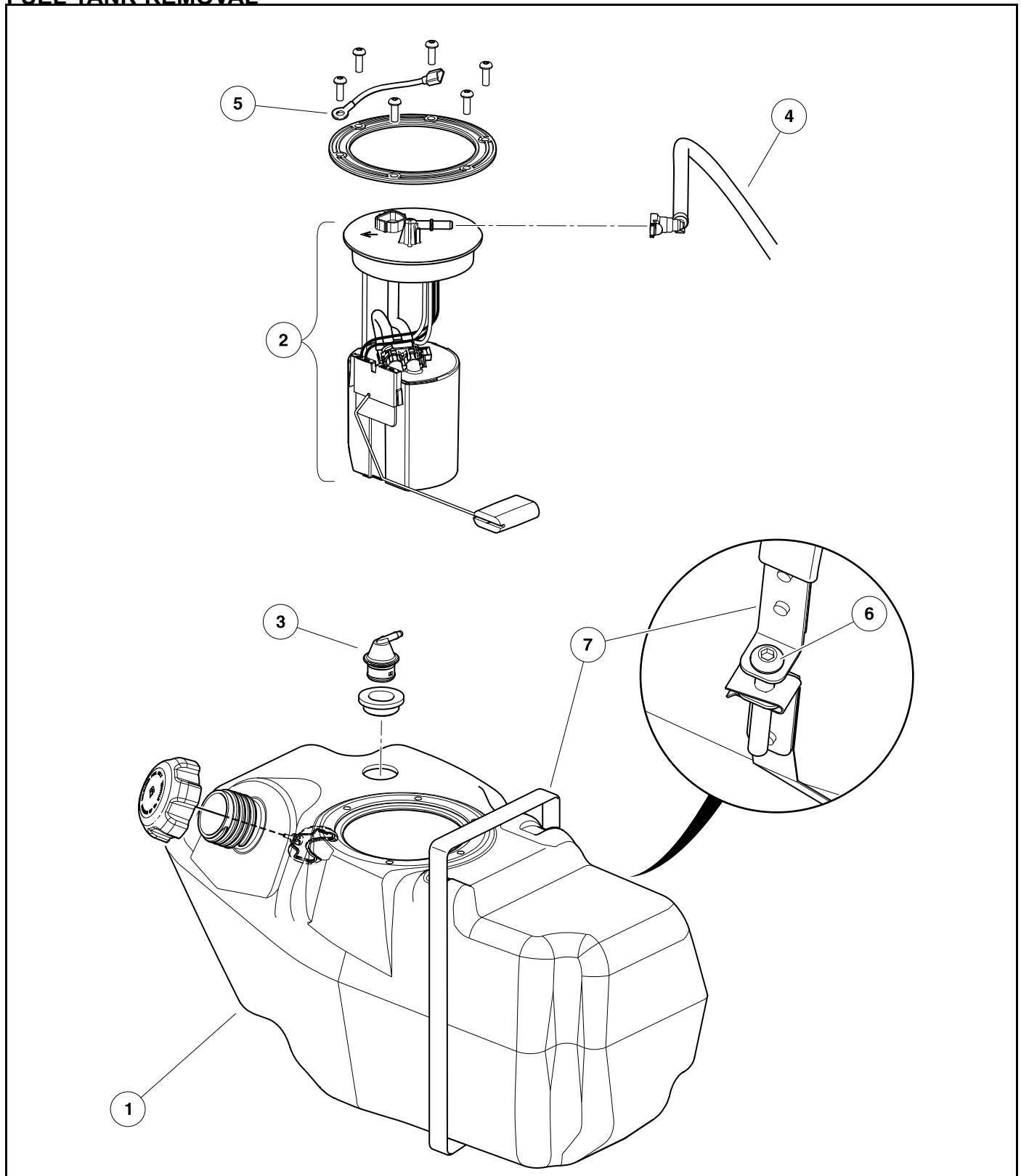

3052D

Figure 14-19 Fuel Tank Removal

1. Disable the vehicle.
2. Set the Maintenance/Operate switch to MAINTENANCE.
3. Disconnect the battery.
4. Clean the top of the fuel tank (1) and fuel pump module (2) (**Figure 14-19, Page 14-21**).
5. Remove gas cap and siphon all fuel from tank into an approved container. **See following DANGER and WARNING.**

### **⚠ DANGER**

- **Gasoline – Flammable! Explosive! Do not smoke. Keep sparks and flames away from the vehicle and service area. Service only in a well-ventilated area.**

### **⚠ WARNING**

- **Do not attempt to siphon fuel using a hose that does not have a built-in suction device.**
  - **Do not attempt to siphon fuel using your mouth.**
6. Disconnect the wire harness plug from fuel pump module.
  7. Disconnect the vent hose from fuel tank vent (3).
  8. Disconnect the fuel line (4) from the fuel pump module and drain into an appropriate container. See Fuel Line Removal. **See following WARNING.**

### **⚠ WARNING**

- **Fuel may be under pressure. Use extreme caution when disconnecting fuel line to prevent the spray of fuel onto hot engine. See Relieving Fuel Pressure.**
  - **Carefully drain any fuel remaining in the hose or pump module into an approved container. Add drained fuel back into fuel tank or dispose of properly.**
9. Disconnect fuel pump module ground wire (5).
  10. Loosen screw (6) securing fuel tank retaining strap (7) and remove fuel tank.

## **FUEL TANK DISPOSAL**

1. Remove gas cap and fuel pump module from tank. See Fuel Pump Module Removal. The cap may be discarded or kept as a spare.
2. In a well-ventilated area, flush the fuel tank with water to remove any remaining fuel.
3. In a well-ventilated area, set the tank upside down so that the water can drain out of it. To make sure that the tank dries completely, allow the tank to sit for 24 hours. **See following CAUTION.**

### **⚠ CAUTION**

- **Dispose of wastewater and fuel tank in accordance with local, state, and federal laws and ordinances.**

## **FUEL TANK STORAGE**

1. Remove gas cap and fuel pump module from tank. See Fuel Pump Module Removal.
2. In a well-ventilated area, flush the fuel tank with water to remove any remaining fuel.

3. In a well-ventilated area, set the tank upside down so that the water can drain out of it. To make sure that the tank dries completely, allow the tank to sit for 24 hours.
4. Completely drain gas from fuel pump module and allow to module to dry.
5. After the module is completely dry, install it in fuel tank. See Fuel Pump Module Installation.
6. Store the tank upside down, with the cap installed, in a well-ventilated area.

## FUEL TANK INSTALLATION

**NOTE:** This gasoline vehicle complies with the California Air Resources Board (CARB) and EPA evaporative emissions regulations when equipped with SAEJ30R9 1/4 in (6.3 mm) fuel vent hose and 3/16 in (4.78 mm) fuel vent hose. To remain in compliance with California and EPA regulations, replace any fuel vent hose on this vehicle with Club Car fuel vent hoses or equivalent.

1. Place fuel tank (1) in vehicle (**Figure 14-19, Page 14-21**).
2. Secure tank with retaining strap (7).
  - 2.1. Position the retaining strap in the indentation of the tank.
  - 2.2. Install the screw (6) into retaining strap and tighten to 26.5 in·lb (3 N·m).
3. Connect fuel pump module ground wire (5) to main wire harness. **See following WARNING.**

### **⚠ WARNING**

- **Always install ground wires during reassembly.**

4. Connect fuel line (4) to fuel pump module (2). **See Fuel Line Installation on page 14-15. See following DANGER.**

### **⚠ DANGER**

- **Ensure line is connected properly to avoid a leak that can cause a fire.**

5. Install the vent line onto the fuel tank vent (3).
6. Connect the wire harness plug to fuel pump module.
7. Clean spilled fuel and remove any drained fuel from the area.
8. Connect the battery.
9. Add fuel to the fuel tank.
10. Disable the vehicle.
11. Set the Maintenance/Operate switch to MAINTENANCE.
12. Turn key switch to the ON position and check for fuel leaks. Repeat as necessary to build fuel pressure. Any leaks found must be fixed.

### **⚠ DANGER**

- **Repair all fuel leaks before returning the vehicle to service.**

13. If no leaks are found, set the Maintenance/Operate switch to OPERATE.

## FUEL FILTER

See General Warnings on page 1-1.

### GENERAL INFORMATION

The fuel filter is located in the fuel tank. It is part of the fuel pump module assembly and should last the life of the vehicle; however, it is replaceable if the need should arise. In addition, the module assembly features a fuel pickup screen to catch larger particles before entering the fuel filter.

### FUEL FILTER REMOVAL

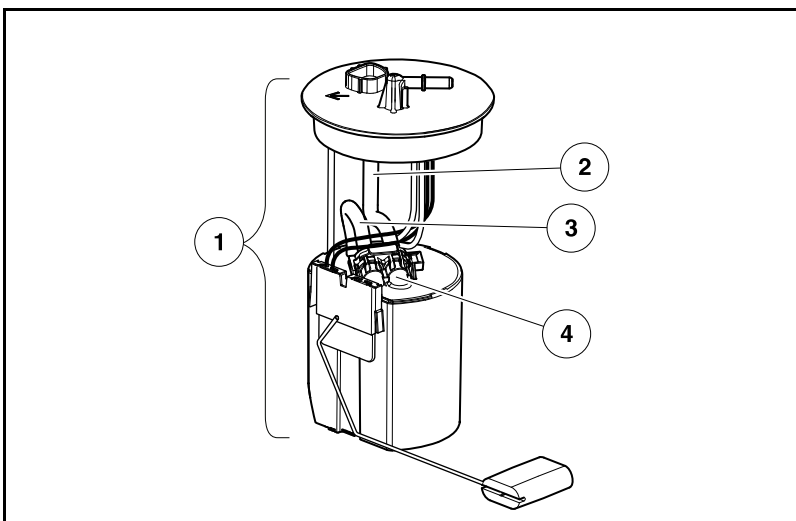

3052E

**Figure 14-20 Fuel Filter Removal**

1. Disable the vehicle.
2. Disconnect the battery.
3. Remove fuel pump module (1) (**Figure 14-20, Page 14-24**). See Fuel Pump Module Removal.
4. Disconnect the flex hoses (2 and 3) from filter (4).
  - 4.1. Pull the hose retainer clip straight up and out of the filter. Do not discard clip.
  - 4.2. Pull the flex hoses straight out of the filter inlet and outlet.
5. Remove filter from fuel pump module and dispose of properly.

### FUEL FILTER INSTALLATION

#### **CAUTION**

- Fuel filter flex hoses are keyed to aid proper installation into fuel pump module.

**NOTE:** The fuel filter is keyed to the fuel pump module to prevent incorrect assembly.

The inlet and outlet flex hoses are keyed to the fuel filter ports to prevent incorrect assembly.

1. Orient fuel filter (4) and insert into fuel pump module (1) until fully seated (**Figure 14-21, Page 14-25**).

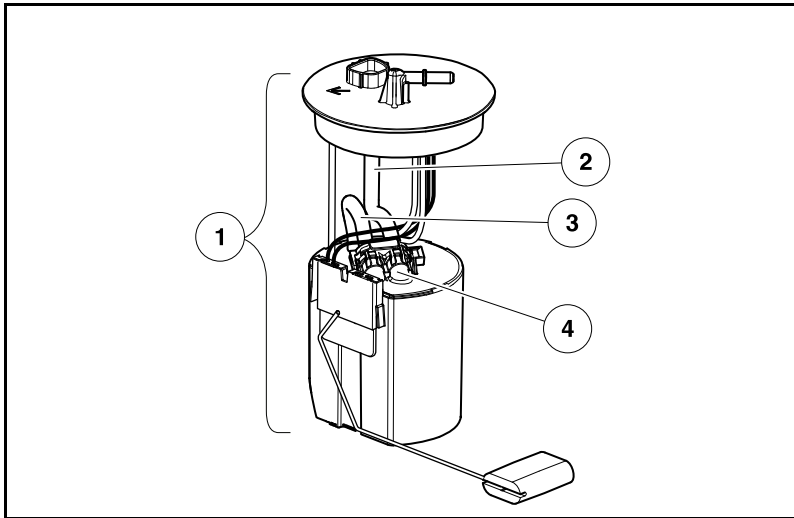

3052E

**Figure 14-21 Fuel Filter Installation**

2. Connect flex hoses (2 and 3) to the fuel filter.
  - 2.1. Orient flex hoses with matching port in filter and push each hose end straight into filter until fully seated.
  - 2.2. Push hose retainer clip straight into filter until fully seated.
3. Install fuel pump module. See Fuel Pump Module Installation.
4. Connect the battery and spark plug wire.
5. Set the Forward/Neutral/Reverse control (FNR) to N.
6. Chock the wheels.
7. Set the Maintenance/Operate switch to MAINTENANCE.
8. Start the engine and check for fuel leaks. **See following DANGER.**

### **⚠ DANGER**

- **Repair all fuel leaks before operating the vehicle.**

9. If no leaks are found, set the Maintenance/Operate switch to OPERATE.

Pagination Page

## **⚠ DANGER**

- See General Warnings on page 1-1.

## **⚠ WARNING**

- See General Warnings on page 1-1.

## MUFFLER

### MUFFLER REMOVAL

1. Disconnect the battery and spark plug wire.
2. If necessary, remove the oxygen sensor (1) from the muffler (2) (**Figure 15-1, Page 15-1**). See Oxygen Sensor Removal.

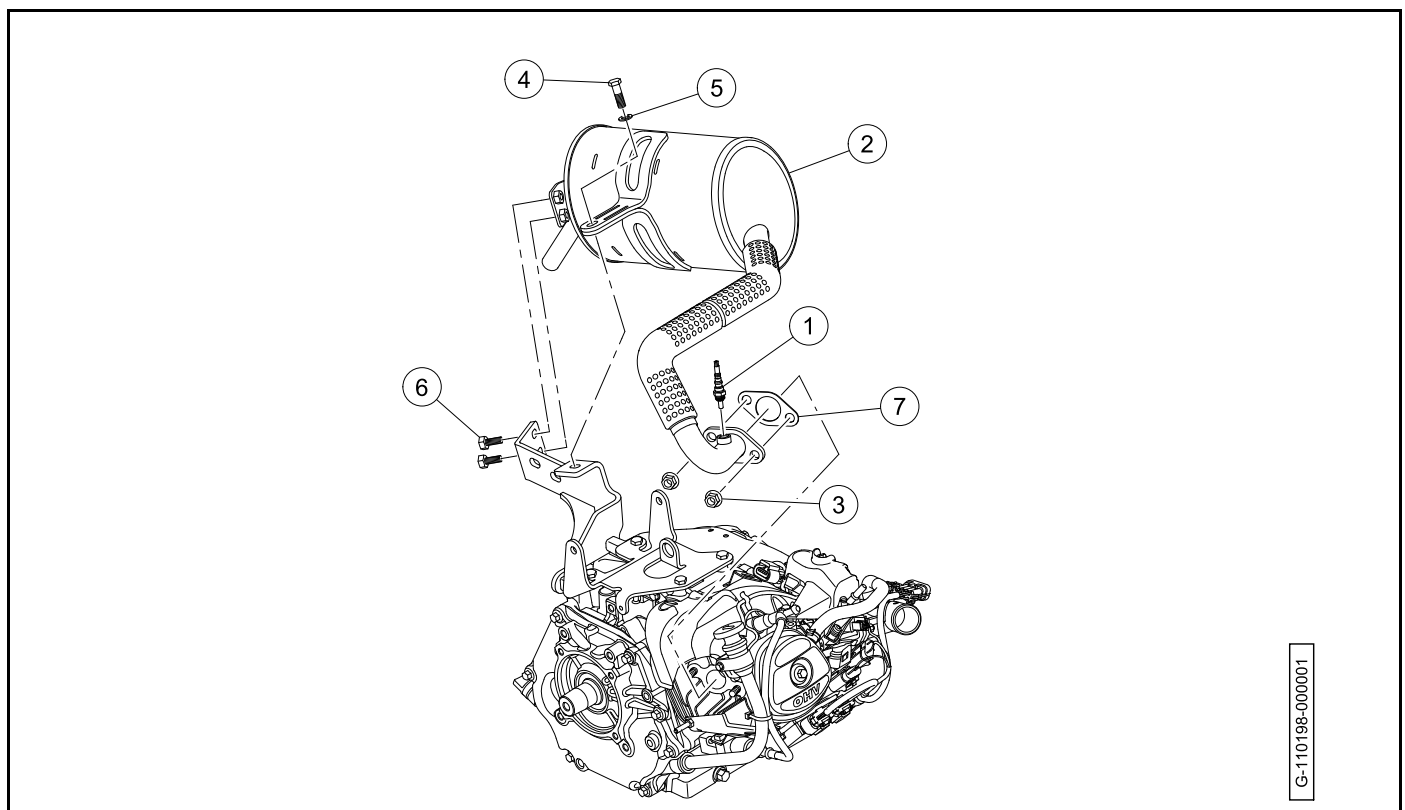
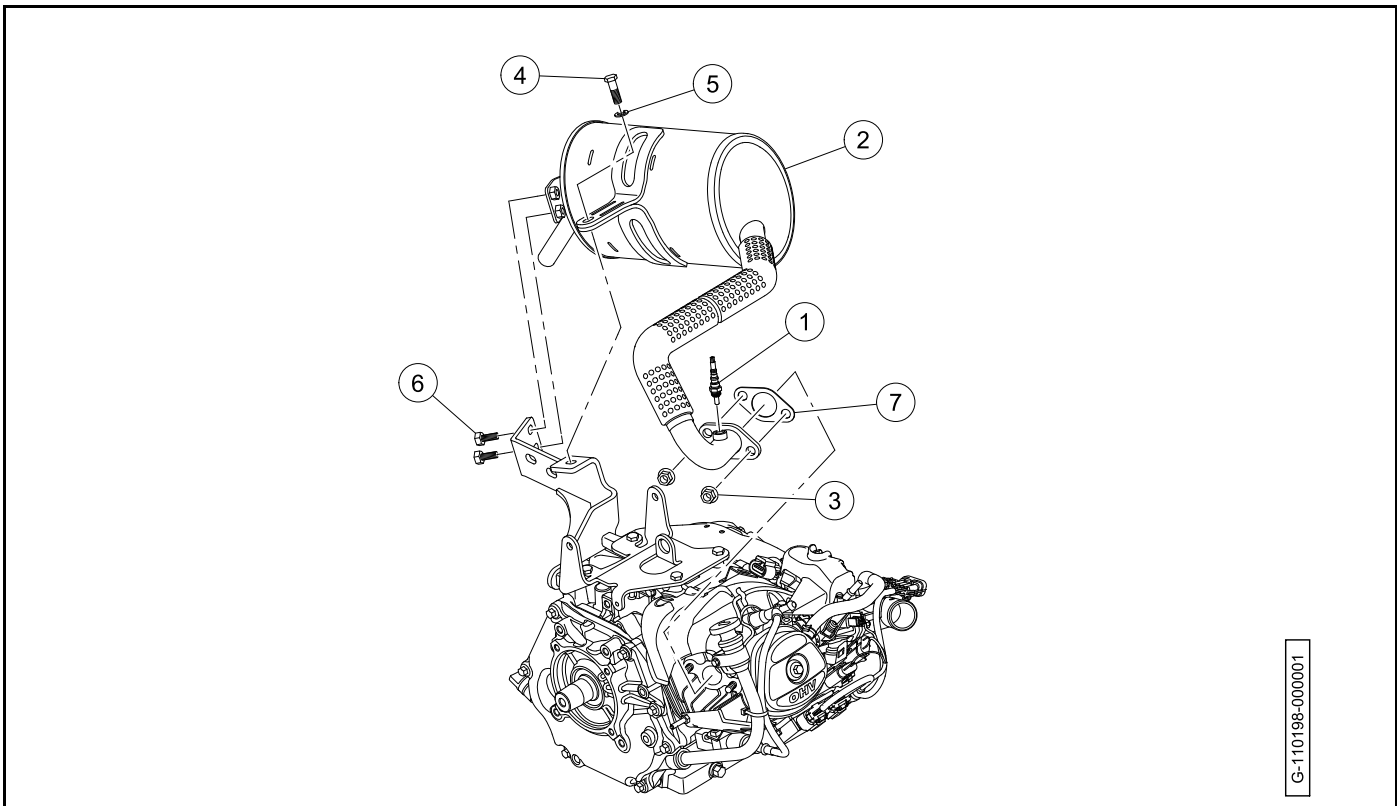

**Figure 15-1 Muffler Removal**

3. Remove the nuts (3).
4. Remove the bolt (4) and washer (5).
5. Remove the bolts (6).
6. Remove the muffler.
7. Remove the exhaust gasket (7).

## MUFFLER INSTALLATION

1. Install the new exhaust gasket (7) on the exhaust port studs (**Figure 15-2, Page 15-2**).



**Figure 15-2 Muffler Installation**

2. Put the muffler (2) into position on the engine.
3. Install the nuts (3), bolt (4), washer (5), and bolts (6). Tighten the hardware by hand.
4. Tighten the hardware in the following order:
  - 4.1. Tighten the nuts (3) to 19 ft·lb (26 N·m).
  - 4.2. Tighten the bolt (4) to 17 ft·lb (23 N·m).
  - 4.3. Tighten the bolts (6) to 17 ft·lb (23 N·m).
5. If the oxygen sensor (1) was removed, install the oxygen sensor. See Oxygen Sensor Installation.
6. Connect the battery and spark plug wire.
7. Set the Forward/Neutral/Reverse control (FNR) to N.
8. Set the Maintenance/Operate switch to MAINTENANCE.
9. Put the chocks against the wheels.

### **⚠ DANGER**

- **Do not operate gasoline vehicle in an enclosed area without proper ventilation. The engine produces carbon monoxide, which is an odorless, deadly poison.**

10. Start the engine.
11. Check for exhaust leaks and correct engine operation. **See following DANGER.**



### **⚠ DANGER**

- See General Warnings on page 1-1.

### **⚠ WARNING**

- See General Warnings on page 1-1.

## GENERAL INFORMATION

The torque converter consists of a drive clutch, a driven clutch, and a drive belt. The drive clutch, which is mounted to the engine, is in the open position when the engine is at idle. At this point, the belt is riding at a low position (smaller diameter) on the drive clutch. The driven clutch is mounted on the transaxle. It is in the closed position, and the drive belt is riding at a high position (large diameter) on it when the engine is at idle.

At the point of clutch engagement, the speed ratio of the drive clutch to the driven clutch provides excellent starting and low-speed torque.

As engine speed increases, centrifugal force on internal weights close the drive clutch, pushing the belt up to a higher position on the clutch (increasing the diameter of the belt loop). As the diameter of the belt loop increases at the drive clutch, the driven clutch is forced open as the diameter of its belt loop decreases.

On steep grades, or when the vehicle is heavily loaded, higher torques are achieved through the use of a torque-sensing ramp device on the driven clutch. This device overcomes the force of the centrifugal weights to close the driven clutch and open the drive clutch, thus increasing axle torque with little or no change in engine RPM.

The engine and torque converter rotate counter-clockwise as viewed from the clutch side of the engine.

To provide optimum performance for the engine and powertrain, the vehicle uses a pair of tuned clutches.

To properly assemble and disassemble the torque converter, the following tools should be used:

- Drive Clutch Hub Puller
- Drive Clutch Puller
- Drive Clutch Holder Tool
- Driven Clutch Cam Puller
- Driven Clutch Puller Plug
- Driven Clutch Cam Press
- Scribe or small pick (not included with clutch tools).

## TROUBLESHOOTING

See General Warnings on page 1-1.

Maintaining proper adjustment of the engine and governor, as well as the torque converter, is essential to the troubleshooting process. If these adjustments are within specifications and, when climbing a steep hill, the engine begins to lose RPM before the drive belt reaches the top of the driven clutch, there is a torque converter problem.

If the torque converter is not operating properly, perform the following steps:

1. Check the governor and throttle settings. See Engine Control Linkages.
2. Inspect the driven clutch for dirt and dust buildup on its component parts. Clean the driven clutch with water to remove any dust or dirt, then drive the vehicle and check for proper operation.
3. If cleaning the driven clutch does not solve the problem, disassemble and thoroughly clean all parts of the drive clutch. Be sure to clean the plastic drive buttons (7) (**Figure 16-2, Page 16-4**).

## DRIVE BELT

See General Warnings on page 1-1.

The drive belt should be inspected semiannually for wear and (or) glazing. If it is excessively worn, frayed, or glazed, replace the belt.

As the drive belt wears, the engine RPM will increase to compensate for the change in torque converter ratio. This will keep the vehicle's maximum ground speed correct. See **Vehicle Specifications**.

### DRIVE BELT REMOVAL

1. Disconnect battery and spark plug wire. See **Disconnecting the Battery-Gasoline Vehicles** on page 1-3.
2. Grasp the belt midway between the drive (2) and driven (1) clutches. Lift upward on the belt to force the sheaves of the driven clutch (1) apart, then roll the belt off the driven clutch by rotating the clutch counterclockwise (**Figure 16-1**, **Page 16-3**). See following **CAUTION**.

#### **⚠ CAUTION**

- Make sure fingers are not underneath the belt when rolling the belt off the driven clutch.

**NOTE:** Roll away from compression to make removal easier.

3. Remove the belt from the drive clutch (2).

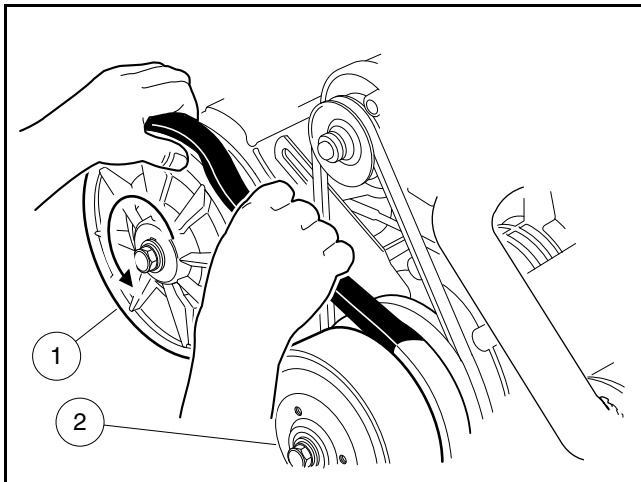

594

**Figure 16-1 Drive Belt Removal**

### DRIVE BELT INSTALLATION

1. Position the new belt on the drive clutch (2), then start the belt over the top of the driven clutch (1).
2. With the belt started onto the driven clutch (1), rotate the driven clutch counterclockwise and roll the belt over the outer, moveable sheave.
3. Connect battery and spark plug wire. See **Connecting the Battery-Gasoline Vehicles** on page 1-3.

## DRIVE CLUTCH

See General Warnings on page 1-1.

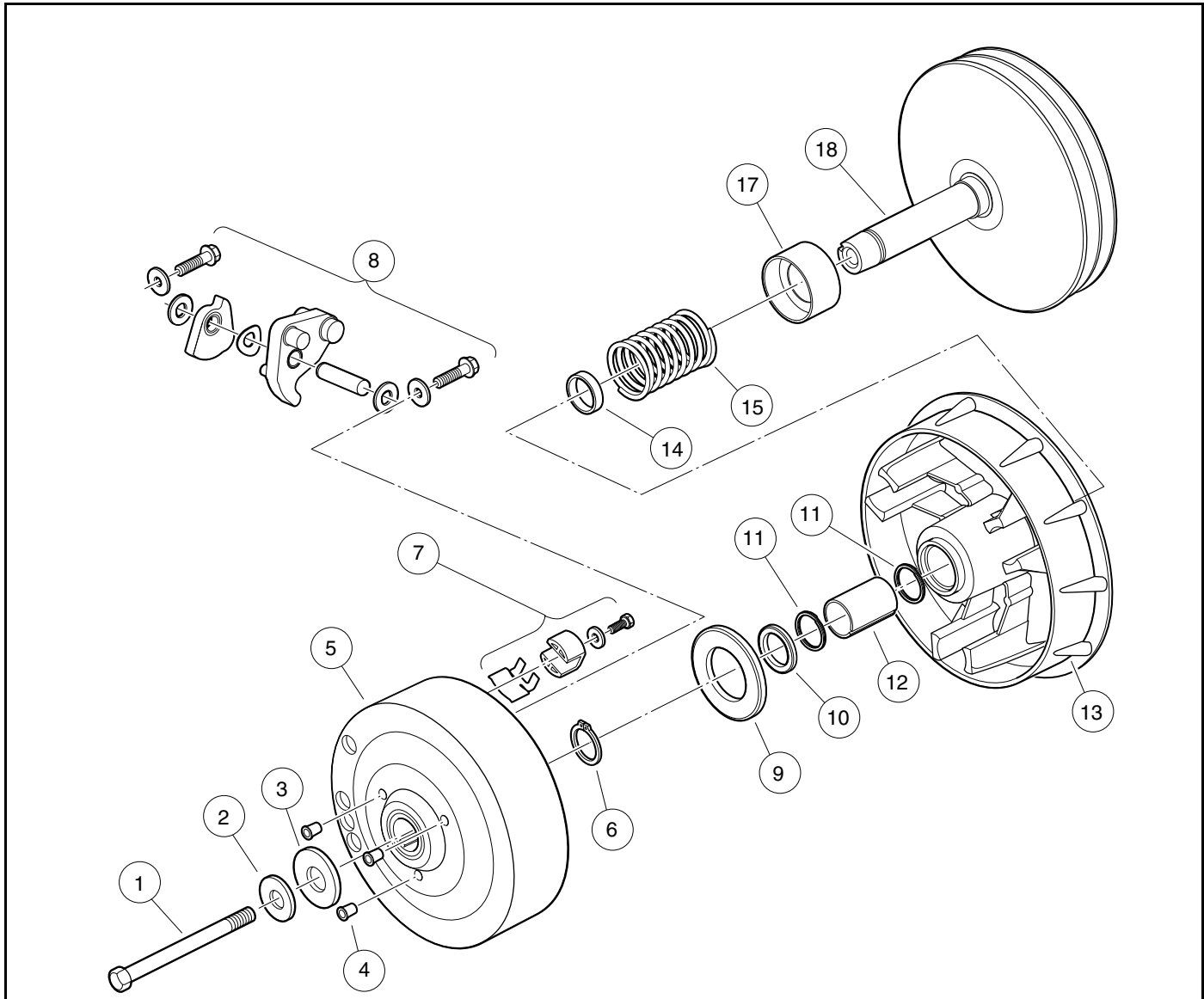

1. Screw, 3/8-24 x 5.75, Patch

2. Washer, Hard, M10

3. Washer, 3/8, Type A, Flat

4. Cap Plug

5. Drive Hub Assy, Drive Clutch

6. Ring, 0.810 in. (20.5 mm) Internal Retaining

7. Drive Clutch Button

10. Retainer

11. Ring, Spiral Backup

12. Bushing, Split, Drive Clutch

13. Sheave, Moveable, Drive

14. Spacer, Fixed Face Shaft

15. Spring, Drive Clutch

16. No Item to Show

8. Drive Clutch Weight	17. Spacer, Idler, Drive
9. Thrust Washer	18. Sheave, Fixed, Drive

2960

Figure 16-2 Drive Clutch – Exploded View

**CAUTION**

- Be very careful when handling the clutches. A clutch that has been dropped will not be properly balanced. If either clutch is dropped, assume that it is damaged and replace it.

**DRIVE CLUTCH REMOVAL**

1. Remove the drive belt as instructed. See Drive Belt Removal on page 16-3.
2. Loosen starter/generator mounting and adjusting hardware and remove starter belt. See WARNING “Moving parts! Do not...” in General Warnings on page 1-1.

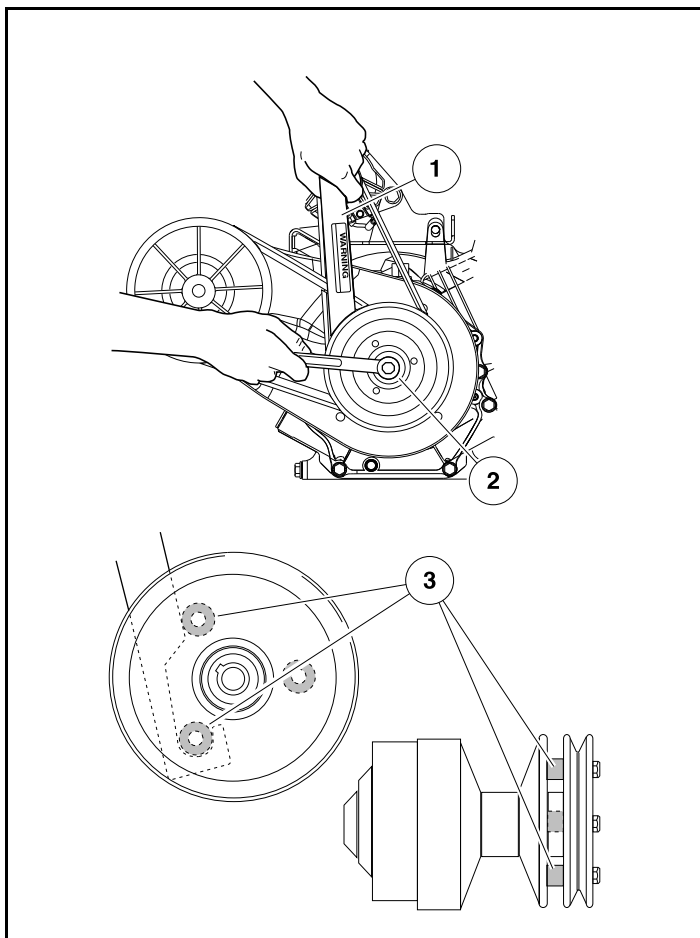

2962

Figure 16-3 Loosen Retaining Bolt

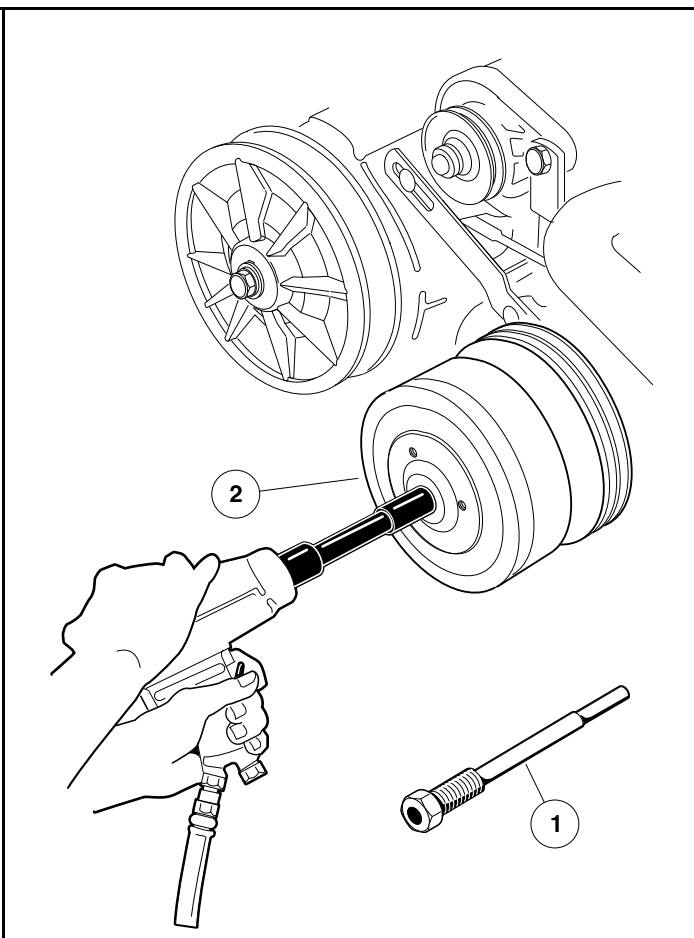

596

Figure 16-4 Drive Clutch Removal

3. Place chocks at the front wheels and lift the rear of the vehicle with a chain hoist or floor jack. Place jack stands under the chassis to support the vehicle. The weight of the powertrain will allow the centerline of the drive clutch to drop below the frame I-beam for access to the bolt securing the drive clutch. See following WARNING.

## **⚠ WARNING**

- Lift only one end of the vehicle at a time. Use a suitable lifting device (chain hoist or hydraulic floor jack) with 1000 lb. (454 kg) minimum lifting capacity. Do not use lifting device to hold vehicle in raised position. Use approved jack stands of proper weight capacity to support the vehicle and chock the wheels that remain on the floor. When not performing a test or service procedure that requires movement of the wheels, lock the brakes.
4. Remove the drive clutch retaining bolt (1) and mounting washers (2 and 3) (Figure 16-2, Page 16-4). See also Figure 16-3, Page 16-5. See following NOTE.

**NOTE:** The drive clutch mounting bolt has right-hand threads.

*The crankshaft has right-hand threads at the clutch mounting hole.*

- 4.1. Use the drive clutch holder tool (1) while tightening or loosening the drive clutch retaining bolt (2) (Figure 16-3, Page 16-5).
- 4.2. Hook clutch holder on boss (3) of pulley located behind drive clutch and push against the adjacent boss with holder.
5. Lubricate the threaded portion of the clutch puller tool (1) with a light oil and thread the clutch puller tool into the clutch retaining bolt hole (Figure 16-4, Page 16-5).
6. Use a 1/2-in. drive air wrench to tighten the clutch puller tool. The drive clutch (2) will pull free of the crankshaft.
7. Support the drive clutch assembly in your hand and back the clutch puller tool out of the crankshaft.

## **⚠ CAUTION**

- Do not hit or tap the clutch with a hammer. Do not pry the clutch. These actions will damage the clutch.

## **DRIVE CLUTCH CLEANING AND INSPECTION**

1. Use a dry, lint-free cloth to clean clutch parts.

## **⚠ CAUTION**

- Do not lubricate the drive clutch. Lubricants attract dirt and dust, which interfere with proper clutch operation.
  - Use only a dry cloth to lightly wipe the shaft of the fixed sheave (18) (Figure 16-2, Page 16-4). Do not use a brush or steel wool. These will damage the surface of the shaft.
  - Do not use solvents. Solvents will damage the lubricating characteristics of the bushings.
2. Inspect the belt contact surfaces of the clutch sheaves for wear. If any area of a sheave contact surface has wear of 0.060 in. (1.52 mm) or more, the clutch should be replaced.

## DRIVE CLUTCH DISASSEMBLY

**⚠ CAUTION**

- The drive clutch is balanced as an assembly. Before disassembly, make match marks on the drive clutch hub and on the moveable sheave so they can be reassembled in the same positions (Figure 16-5, Page 16-7).

1. Make match marks on the drive clutch hub and on the moveable face (Figure 16-5, Page 16-7).
2. Remove the drive clutch hub (5) (Figure 16-2, Page 16-4):
  - 2.1. Remove the three plugs (4) from the clutch puller attachment holes.
  - 2.2. Thread the center bolt of the Drive Clutch Hub Puller (1) into clutch until the stop nut touches the clutch, then back the bolt out one-half turn (Figure 16-6, Page 16-7).
  - 2.3. Thread the three small bolts of the puller into corresponding holes in the clutch. Tighten bolts evenly, making sure the face of the puller plate is parallel to the face of the clutch (Figure 16-6, Page 16-7).
  - 2.4. Unscrew the puller center bolt out of the clutch to pull drive clutch hub off.

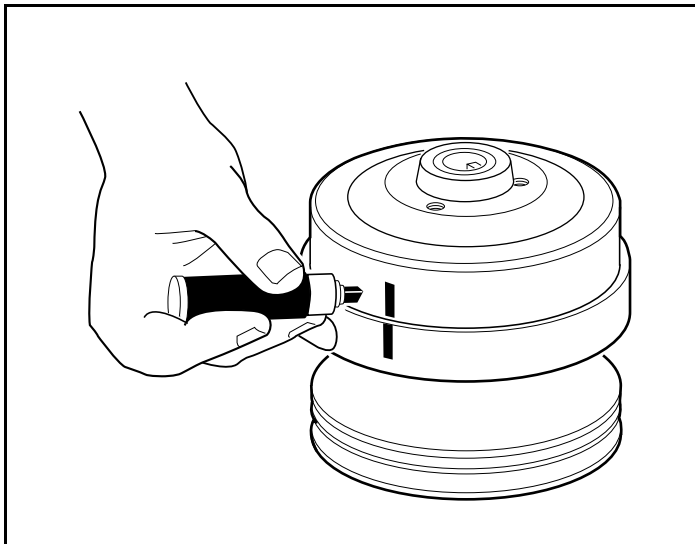

598

Figure 16-5 Mark Drive Clutch Hub

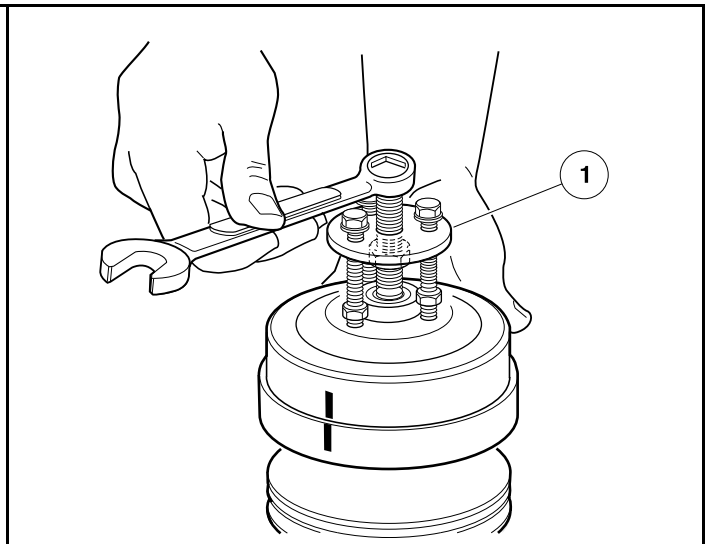

599

Figure 16-6 Remove Drive Clutch Hub

3. Remove the thrust washer (9) from the moveable sheave (13) (Figure 16-2, Page 16-4).
4. Remove the drive buttons (3) by removing the screws (1), flat washers (2), and drive button take-up springs (4) as shown (Figure 16-7, Page 16-8).

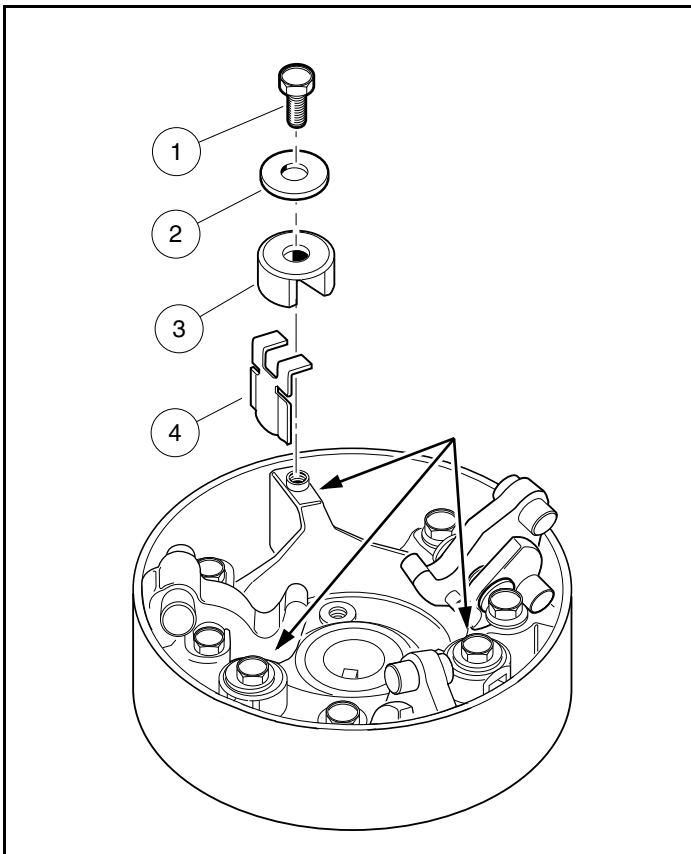

3053

Figure 16-7 Drive Button Mounting

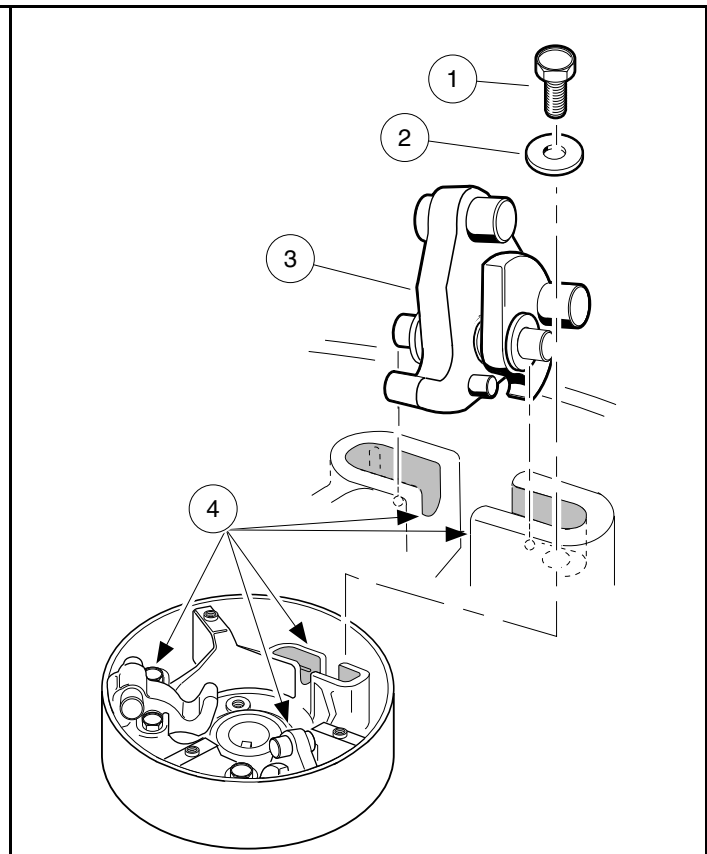

601

Figure 16-8 Weight Position

5. Remove the clutch weights:
  - 5.1. Remove the screws (1) and flat washers (2) attaching the weights (3) as shown (Figure 16-8, Page 16-8).
  - 5.2. Pull the weight assemblies (3), with pins, from slots (4) in the clutch. **See following NOTE.**

**NOTE:** Before removing, note the orientation of the wave washer (1) and secondary weight (2) on the primary weight (3) (Figure 16-9, Page 16-9).

- 5.3. Remove the plastic washers, weights (2 and 3) and wave washer (1) from the pin (4). Retain all parts.



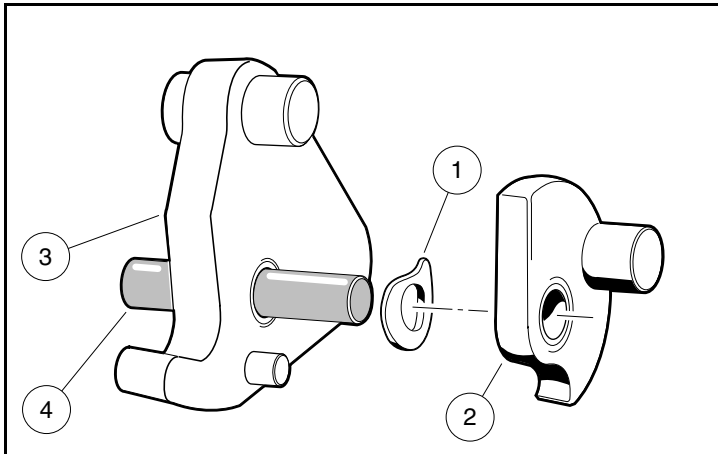

602

**Figure 16-9 Primary and Secondary Weights, Wave Washer and Pin**

- Remove the retaining ring (6) from the shaft of the fixed sheave (18) and slide the moveable sheave (13) off the shaft (**Figure 16-2, Page 16-4**). See following **NOTE**.

**NOTE:** If the moveable sheave is removed from the hub of the fixed sheave, the spiral back-up rings (11) must be replaced with new rings (**Figure 16-2, Page 16-4**).

- Remove the spacer (14) and spring (15) (**Figure 16-2, Page 16-4**).
- Use a scribe or small pick to remove the spiral backup rings (11) from each end of the bore in the fixed sheave (**Figure 16-2, Page 16-4**). See also **Figure 16-10, Page 16-9**. Discard the rings.

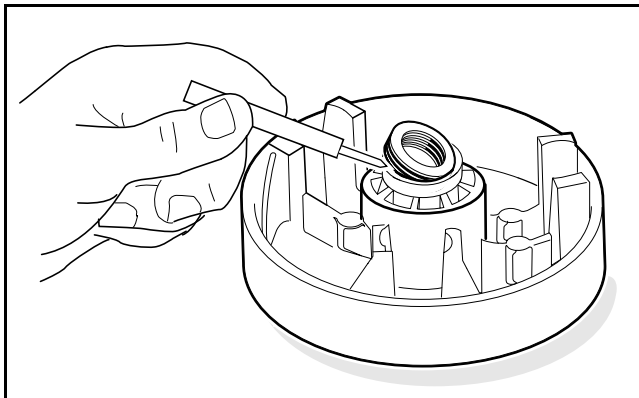

605

**Figure 16-10 Spiral Back-up Rings**

## INSPECTION OF DRIVE CLUTCH PARTS

- Inspect the idler spacer (17) for smoothness (**Figure 16-2, Page 16-4**).
- Inspect the bore of the moveable sheave (13) for scarring or wear. The moveable sheave must be replaced if the bore is worn to a diameter of 0.883 in. (22.4 mm) or larger (**Figure 16-2, Page 16-4**).
- Inspect the steel shaft on the fixed sheave (18). There should be no measurable wear anywhere on the shaft. Replace the shaft if it is worn, scratched, or damaged.
- Inspect the thrust washer (9) for wear. If it is worn more than 0.030 in. (0.76 mm), turn it over or replace it with a new one.

5. Inspect the primary weights (8) and the hub casting for wear. If the primary weights show signs they are touching the casting, the tips of the weights have worn beyond specification and they must be replaced.
6. Inspect the pins on the primary weights (8). There should be no measurable wear. Replace them if they are worn, scratched, or damaged.
7. Inspect the drive belt pulley sheaves for excessive wear or damage. If the sheaves are excessively worn or damaged, replace the entire fixed sheave.

## DRIVE CLUTCH ASSEMBLY

1. Install the spring (15) into the cup of the idler spacer (17).
2. Install the spacer (14) onto the shaft of the fixed sheave.
3. Install a new spiral backup ring (11) in each end of the bore of the moveable sheave (13).
4. Install the moveable sheave (13) onto the shaft of the fixed sheave (18).

### **⚠ CAUTION**

- To avoid damaging the spiral back-up rings, be very careful when installing the moveable sheave.

- 4.1. Rotate the moveable sheave clockwise while installing it onto the shaft.
- 4.2. Install the retaining ring (6) (**Figure 16-2, Page 16-4**).
5. Install the primary weights (3) on the mounting pins (4) (**Figure 16-9, Page 16-9**).
6. Install a wave washer (1) on each mounting pin (4). Make sure that the concave side of the washer faces the side of the primary weight (3) with the small guide pin protruding from it (**Figure 16-9, Page 16-9**).
7. Install the secondary weights (2) onto the mounting pins (4) with the weight pins on the secondary weights pointing away from the primary weights (3). The wave washers should be between the primary and secondary weights (**Figure 16-9, Page 16-9**).
8. Install white plastic flat washers on each end of the mounting pin and push them against the outside surfaces of the weights. Center the weights and washers on the mounting pin (**Figure 16-11, Page 16-10**).
9. Install the weight assemblies into the slots (4) in the hub casting (**Figure 16-8, Page 16-8**). Make sure the mounting pin protrudes an equal amount on each side of the weights when the assemblies are in position (**Figure 16-11, Page 16-10**).

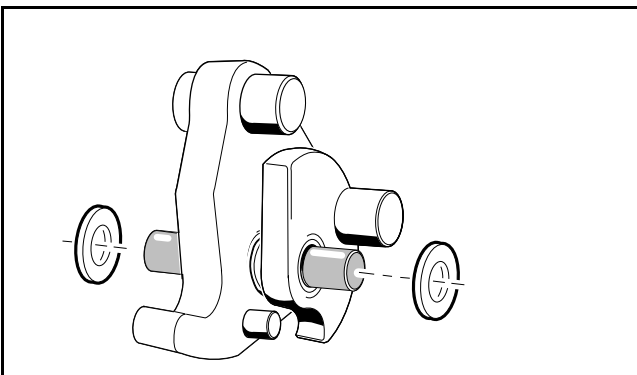

606

**Figure 16-11 Install White Washers**

10. Install the 1/4-20 bolts (1) and washers (2) and tighten them to 10 ft-lb (13 N·m) (**Figure 16-8, Page 16-8**). **See following NOTE.**

**NOTE:** Make sure there is at least a (minimum) gap of 0.020 in. (0.51 mm) between each end of the mounting pin and the mounting bolt.

11. Install three drive button take-up springs.
- 11.1. Install each spring on right-hand side of the three button mounting posts (when looking into the interior of the clutch drive hub, and with the rib at a twelve o'clock position) as shown (**Figure 16-12, Page 16-11**).
12. Compress each take-up spring and install the drive button over the rib and take-up spring (**Figure 16-7, Page 16-8**).
13. Install a drive button retaining bolt (1) with flat washer (2) through each button (3) and into the rib. Tighten the bolts to 34 in·lb (3.8 N·m) (**Figure 16-7, Page 16-8**).
14. Install the thrust washer (9) onto the moveable sheave (13) (**Figure 16-2, Page 16-4**).
15. Install the hub assembly (5) on the moveable sheave (13) and align the match marks made before disassembling the clutch. Press the hub assembly on by hand.
16. Replace the three plastic plugs (4) into the holes (**Figure 16-2, Page 16-4**).

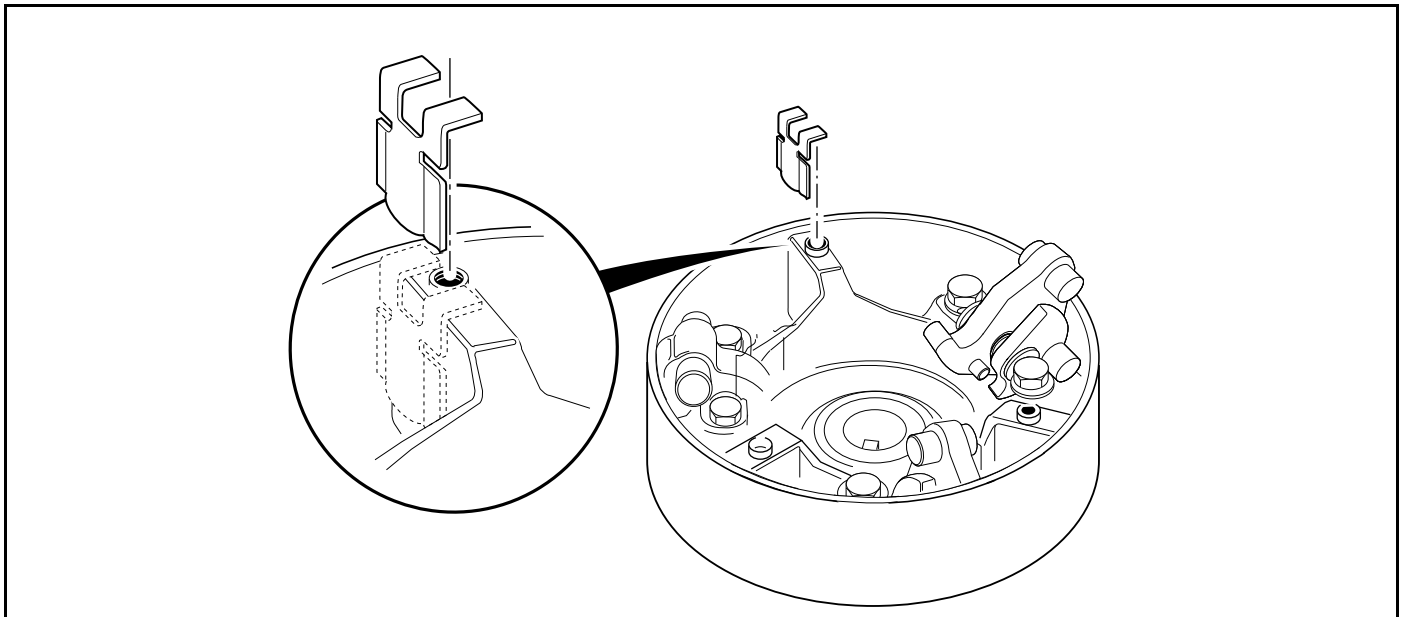

3054

**Figure 16-12** Correct Orientation of Drive Button Take-up Springs

## DRIVE CLUTCH INSTALLATION

1. Place the drive clutch assembly on the crankshaft taper. Position the mounting washers (2 and 3) on the bolt (1) and start the bolt into the crankshaft (**Figure 16-2, Page 16-4**). **See following NOTE.**

**NOTE:** The drive clutch retaining bolt has right-hand threads. The manufacturer recommends replacing the drive clutch retaining bolt when installing the drive clutch. If a new bolt is not available, clean the threads of the original bolt and apply Loctite® 242 to the threaded end prior to installation.

2. Tighten the drive clutch retaining bolt (1) to 35 ft·lb (47.5 N·m) (**Figure 16-2, Page 16-4**).
3. Install the starter/generator belt and adjust belt tension as instructed. **See Belt Tension Adjustment for EFI Engines, Section 12, Page 12-15.**
4. Install the drive belt as instructed. **See Drive Belt Installation on page 16-3.**
5. Connect battery and spark plug wire. **See Connecting the Battery-Gasoline Vehicles on page 1-3.**
6. Drive the vehicle and check for proper operation.

## DRIVEN CLUTCH

See General Warnings on page 1-1.

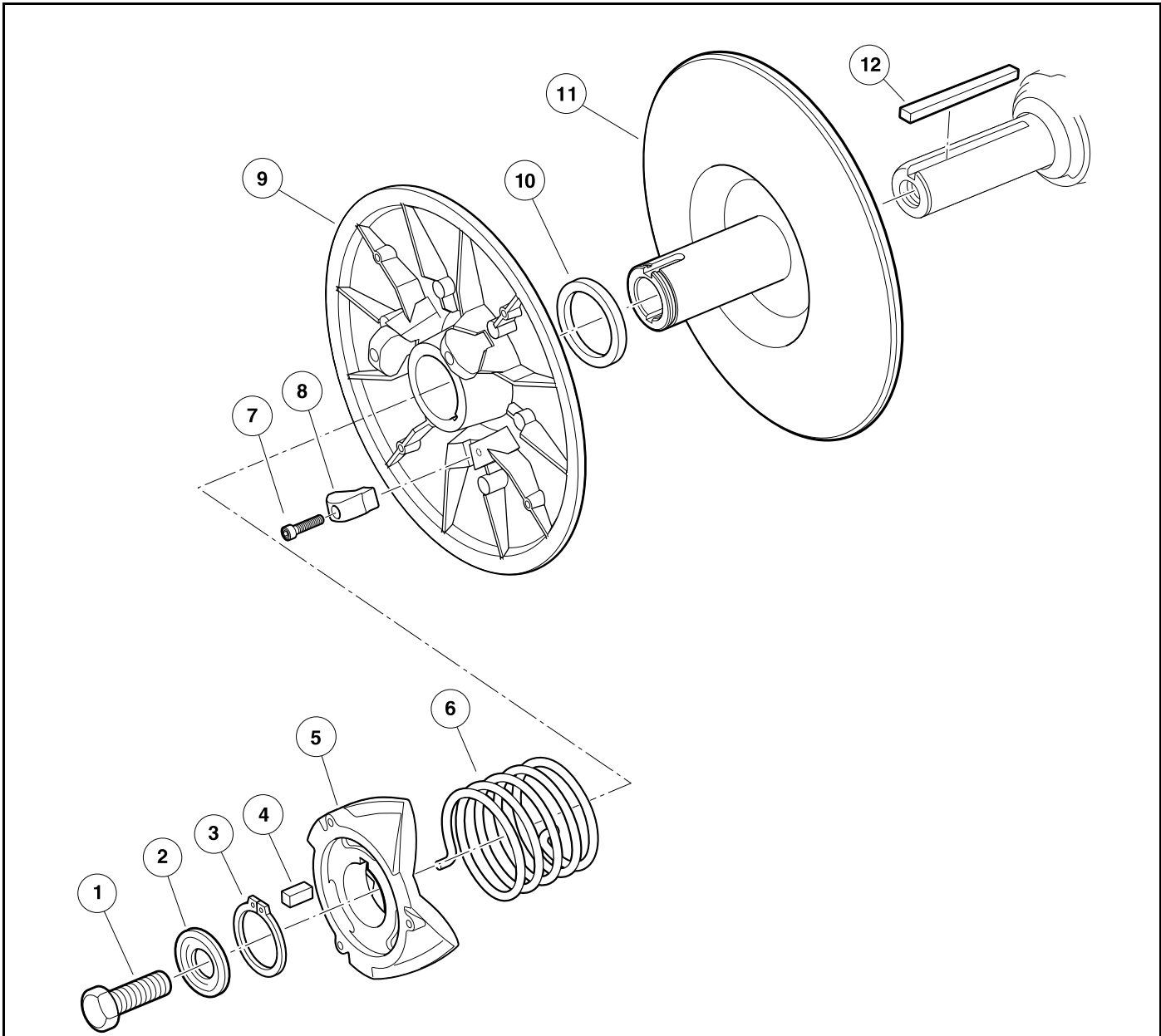

1. Screw, 5/16-18 X 3/4 Hex-Head with Patch

2. Washer, Driven Clutch

3. Ring, Retaining

4. Key, Driven Clutch

7. Screw, #8-32 X 3/4, Socket-Head Cap

8. Button, Drive

9. Sheave, Movable, Driven

10. Washer, Acetal, Driven Clutch

5. Cam, Driven Clutch	11. Sheave, Fixed, Driven
6. Spring, Driven Clutch, CCW, Red	12. Key, 3/16 in. (4.7 mm) Square X 1.50 in. (38 mm) Long

2961

Figure 16-13 Driven Clutch – Exploded View

## DRIVEN CLUTCH REMOVAL

1. Remove the drive belt as instructed. **See Drive Belt Removal on page 16-3.**
2. Remove the bolt (1) and mounting washer (2) from the transaxle input shaft (**Figure 16-13, Page 16-12**). Discard the bolt.

**NOTE:** The bolt (1) must be replaced with a new bolt containing a locking patch that will prevent the bolt from loosening.

3. Grasp the driven clutch assembly and slide it off the shaft.
4. Leave the key (12) in the keyway.

## DRIVEN CLUTCH DISASSEMBLY

### **⚠ CAUTION**

- The driven clutch is balanced as an assembly. Before disassembly, make match marks on the driven clutch fixed sheave and moveable sheave so they can be reassembled in the same positions.

1. Make match marks on the driven clutch fixed sheave and on the moveable sheave to maintain balance upon reassembly.
2. Set the edge of the clutch body (1) on a clean, flat surface (**Figure 16-14, Page 16-13**).

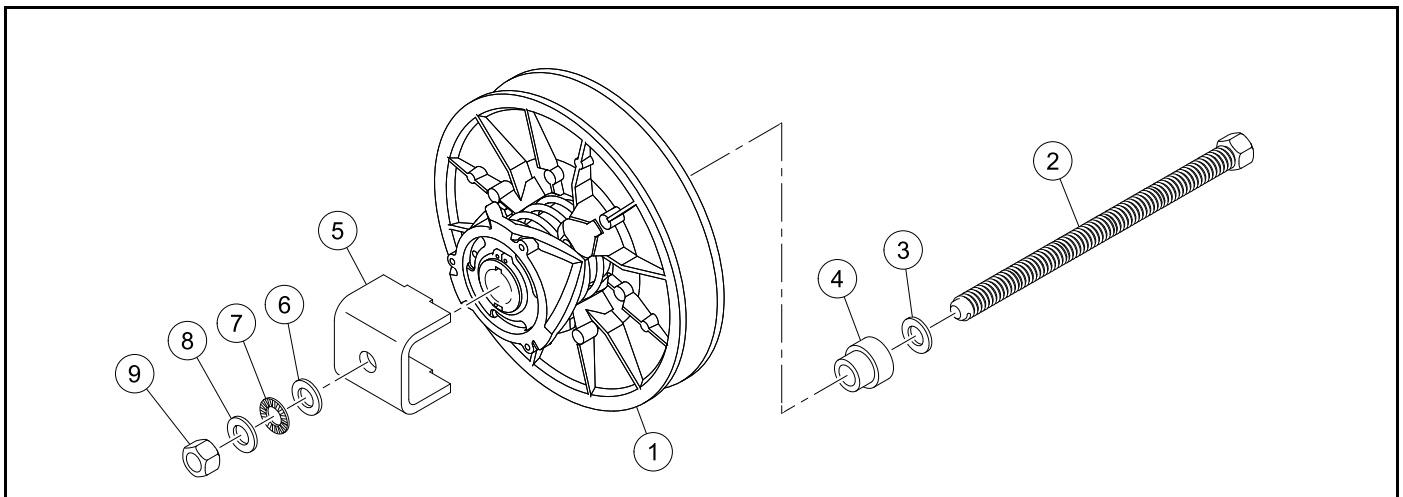

Figure 16-14 Driven Clutch Tool - Disassembly

3. Assemble the threaded bolt (2) through the washer (3) and thrust collar (4).

**NOTE:** It is very important that the bolt, washers, and thrust bearing assembly be assembled in the order described and shown.

4. Slide the threaded bolt assembly through the clutch body until the threaded bolt and thrust collar are against the fixed sheave.

5. Install the cam press plate (5), thrust washer (6), thrust bearing (7), thrust washer (8), and nut (9) onto the threaded bolt.
6. Thread the nut down onto the cam hub, centering the press hub onto the cam hub.
7. Use two wrenches and hold the threaded bolt head while tightening the cam press plate to press the cam onto the keyed shaft. Advance the cam press plate until it is firm against the shaft end.

### **⚠ WARNING**

- Do not place fingers under the cam when removing the cam. The moveable face may spin when the cam buttons release from the cam ramps, resulting in severe personal injury.

8. Remove the retaining ring (10) (Figure 16-15, Page 16-14).

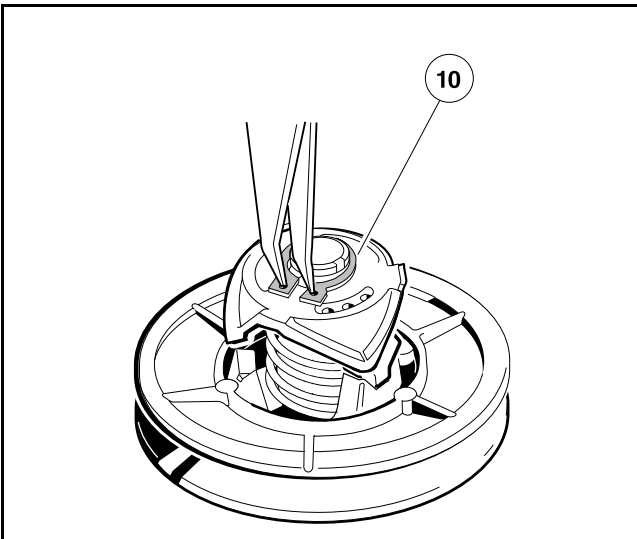

608B

Figure 16-15 Remove Retaining Ring

9. Insert a puller plug (11) into the shaft bore (Figure 16-16, Page 16-15).

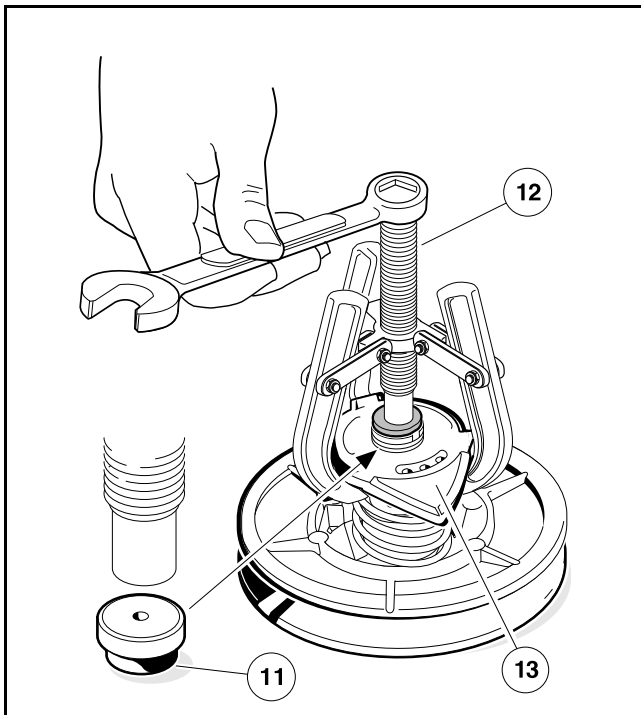

609B

Figure 16-16 Cam Removal

10. Use a driven clutch cam puller (12) to remove the cam (13) from the fixed sheave.
11. Remove the spring (14) (Figure 16-17, Page 16-15).

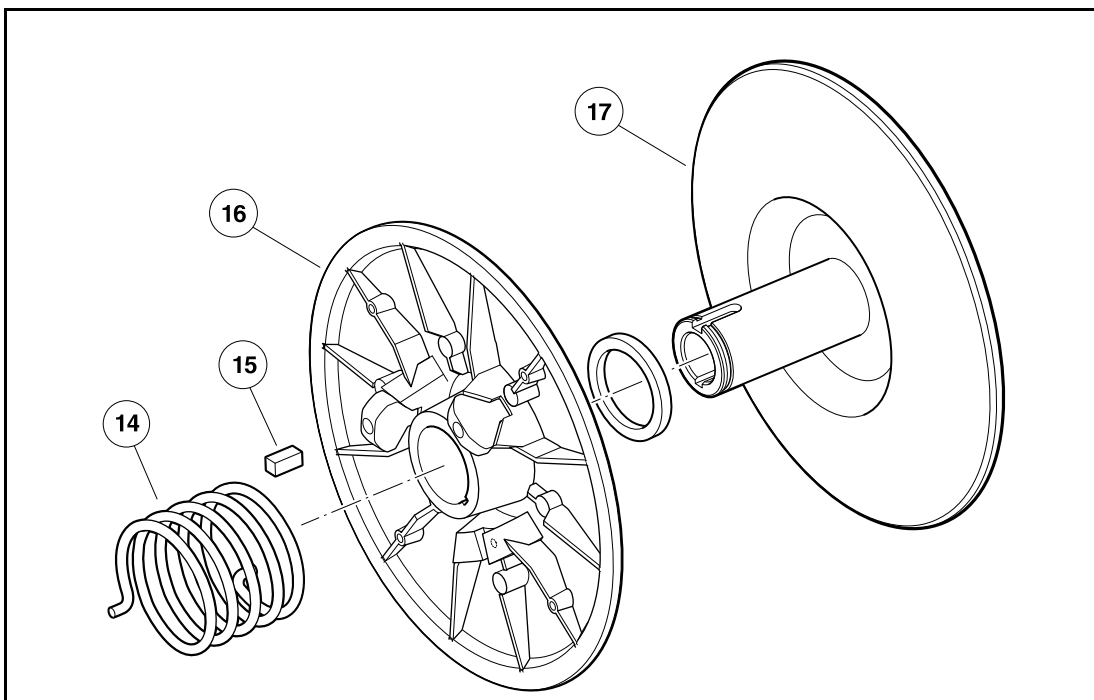

2961B

Figure 16-17 Driven Clutch Disassembly

12. Retain the key (15).

- Slide the moveable sheave (16) off the fixed sheave (17).

## DRIVEN CLUTCH INSPECTION

- Inspect the cam for excessive wear. Replace it if necessary.
- Inspect the drive buttons (2) for excessive wear (**Figure 16-18, Page 16-16**). Replace if necessary. To remove the drive buttons, remove the socket-head cap screws (1) and then the buttons.

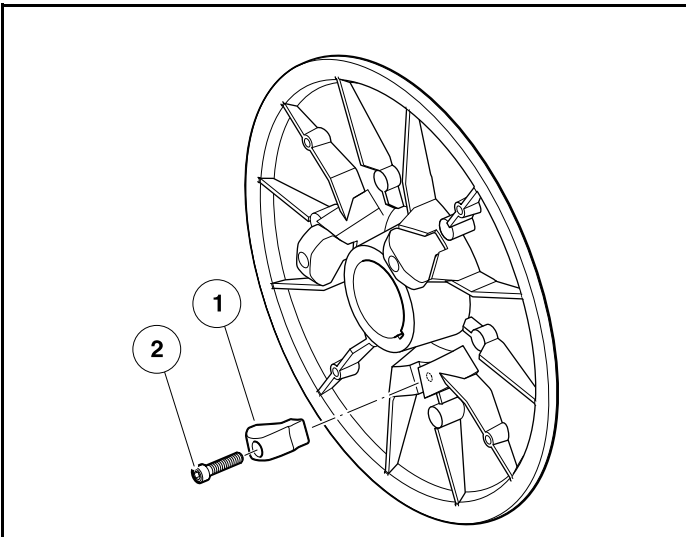

2961C

**Figure 16-18 Drive Button Inspection**

- Inspect the smooth surface on the fixed and moveable sheaves. Sheaves must be replaced if surfaces are worn more than 0.060 in. (1.5 mm).
- Inspect the bronze bearing in the moveable sheave. If the bearing bore diameter is more than 1.384 in. (35.15 mm), the entire moveable sheave must be replaced.
- Inspect the shaft of the fixed sheave. There should be no noticeable wear. Replace the fixed sheave if it is worn, scratched or damaged.
- Inspect the retaining ring. If the outside diameter is more than 1.607 in. (40.82 mm), replace the retaining ring.

## DRIVEN CLUTCH ASSEMBLY

- Place the three drive buttons (2) in position. Apply one drop of Loctite® 222 to each of the socket-head cap screws (1) and then install and tighten them to 8 in·lb (0.9 N·m) (**Figure 16-19, Page 16-17**).



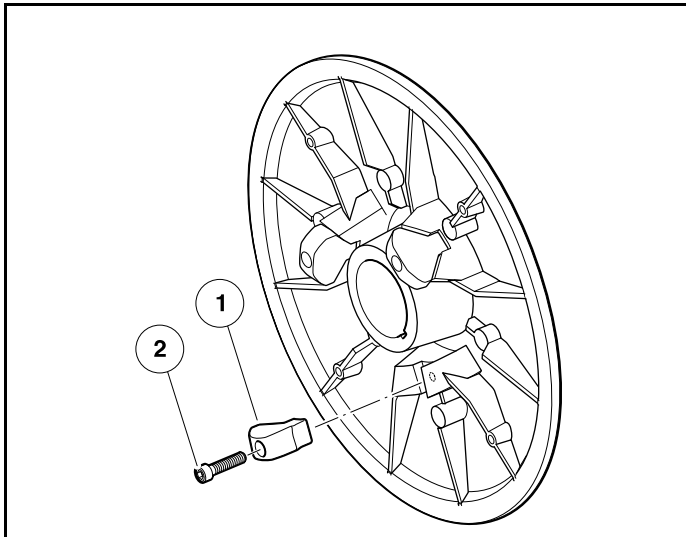

2961C

Figure 16-19 Drive Button Installation

- Slide the acetal washer (3) and moveable sheave (4) onto the fixed sheave (5) (Figure 16-20, Page 16-17).

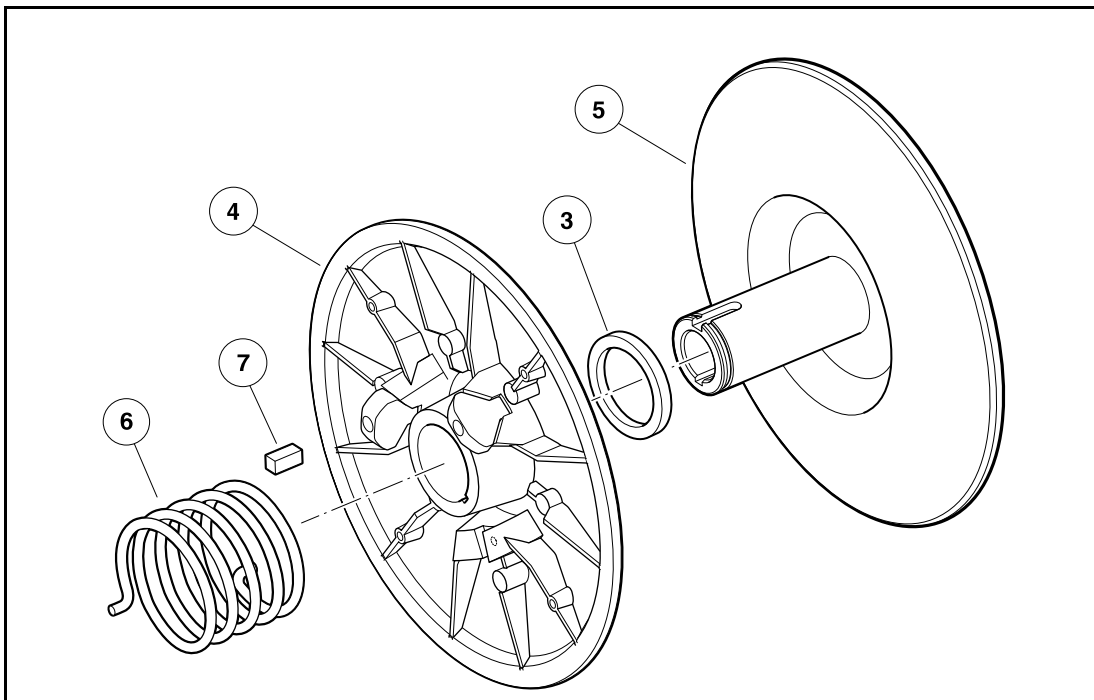

2961D

Figure 16-20 Driven Clutch Assembly

- Place the end of the spring (6) into the hole in the moveable sheave (9).
- Install the key (7) into the keyway of the fixed sheave shaft.
- Holding the cam (8) in position for assembly on the shaft, install the other end of the spring into the center spring hole of the cam. Rotate the cam until the keyway is aligned with the key on the fixed sheave, and then start the cam onto the shaft approximately 1/4 to 3/8 in. (6.3 to 9.5 mm).
- With the clutch loosely assembled, set the edge of the clutch body (9) on a clean, flat surface (Figure 16-21, Page 16-18).

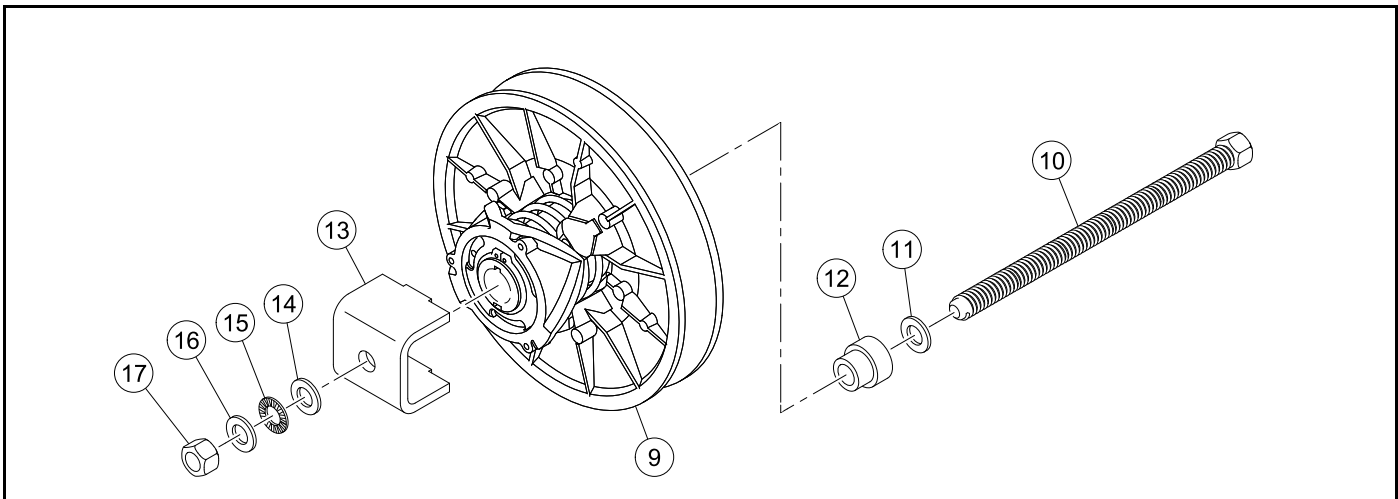

Figure 16-21 Driven Clutch Tool - Assembly

7. Assemble the threaded bolt (10) through the washer (11) and thrust collar (12).

**NOTE:** It is very important that the bolt, washers, and thrust bearing assembly be assembled in the order described and shown.

8. Slide the threaded bolt assembly through the clutch body until the threaded bolt and thrust collar are against the fixed sheave.
9. Hold the clutch assembly and cam installation tool together and place the fixed sheave down on spaced blocks.
10. Install the cam press plate (13), thrust washer (14), thrust bearing (15), thrust washer (16), and nut (17) onto the threaded bolt.
11. Thread the nut down onto the cam hub, centering the press hub onto the cam hub.
12. Hold the fixed sheave of the clutch and rotate the moveable sheave of the clutch one-third turn counterclockwise. The match marks made before disassembly should now align.
13. Use two wrenches and hold the threaded bolt head while tightening the cam press plate to press the cam onto the keyed shaft. Advance the cam press plate until it is firm against the shaft end.

### **⚠ WARNING**

- Do not place fingers under the cam when removing the cam. The moveable face may spin when the cam buttons release from the cam ramps, resulting in severe personal injury.

14. Install the retaining ring (18) (Figure 16-22, Page 16-19).

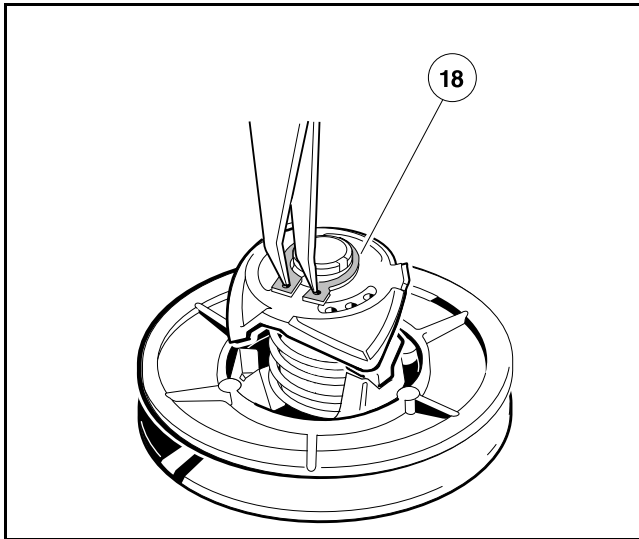

608C

Figure 16-22 Install Retaining Ring

15. Remove the driven clutch tool.

## DRIVEN CLUTCH INSTALLATION

1. To install the driven clutch, reverse the removal procedure.
2. Make sure that the washer (2) is mounted with the flat portion of the washer against the driven clutch (**Figure 16-13, Page 16-12**).
3. Tighten the new bolt (1) to 18 ft·lb (24.4 N·m). **See following NOTE.**

**NOTE:** The bolt (1) must be replaced with a new bolt containing a locking patch that will prevent the bolt from loosening.

4. Connect the battery and spark plug wire.

Pagination Page

## **⚠ DANGER**

- See General Warnings on page 1-1.

## **⚠ WARNING**

- See General Warnings on page 1-1.

## GENERAL INFORMATION

The vehicles addressed in this manual are equipped with heavy-duty transaxles. The transaxle utilizes internal gearing to change vehicle direction. Because the transaxle is used to reverse vehicle direction, the engine, drive clutch, belt, and driven clutch rotate in the same direction; therefore, the engine and clutches are not subjected to reversing loads. This reduces maintenance requirements on the engine and clutches. With the transaxle, power is transferred from the engine through the drive clutch, the drive belt, the driven clutch, and then through the transaxle to the wheels.

### FORWARD/NEUTRAL/REVERSE CONTROL (FNR)

A shifter lever, connected to a shifter arm, is used to change the gears to one of three shift positions: F (Forward), N (Neutral), or R (Reverse). Bring the vehicle to a complete stop before changing F or R direction.

### MAINTENANCE/OPERATE SWITCH

For the convenience of the trained technician, there is a Maintenance/Operate switch located on the seat support panel under the seat (**Figure 17-1, Page 17-1**). The Maintenance/Operate switch has two positions, MAINTENANCE and OPERATE, which are clearly marked.

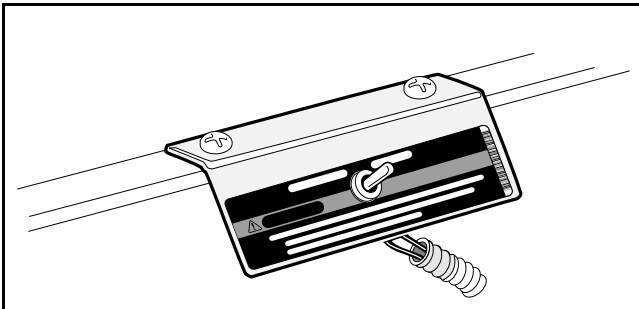

81

**Figure 17-1 MAINTENANCE/OPERATE Switch**

During normal vehicle operation, the Maintenance/Operate switch in the OPERATE position prevents the engine from running when the Forward/Neutral/Reverse control (FNR) is in the NEUTRAL position. If a vehicle is started in F or REVERSE and then shifted to NEUTRAL, the engine will stop running.

When the switch is in the MAINTENANCE position, it will allow the technician to run the engine in the NEUTRAL position to perform certain maintenance and/or repair functions. With the switch in this position, the vehicle will not operate if the Forward/Neutral/Reverse control (FNR) is placed in either the F or REVERSE position. **See following WARNING and NOTE.**

## **⚠ WARNING**

- With the switch in the **MAINTENANCE** position and the engine running, the vehicle may move suddenly if the **Forward/Neutral/Reverse control (FNR)** is shifted or accidentally bumped. To prevent this, chock the front and rear wheels and firmly set the park brake before servicing or leaving the vehicle.

**NOTE:** Be sure to return the switch to the **OPERATE** position after servicing the vehicle, or it will not run with the Forward/Reverse handle in either the **F** or **REVERSE** position.

## **GOVERNOR SYSTEM**

The governor system regulates vehicle ground speed. It is mounted inside the transaxle and is driven by transaxle gears. If any of the governor linkages are removed in order to service other components, readjustment of the governor linkage is required. **See Governor Cable Installation and Adjustment on page 14-6.**

## **TRANSAXLE SERVICE**

The transaxle is extremely durable and should require very little service under normal operating conditions. The only service required is to maintain proper lubricant level. **See Lubrication on page 17-2.** Under normal operating conditions, adjustment to the system should not be required.

## **LUBRICATION**

There are two oil port plugs located on the right (driven clutch) side of the transaxle (**Figure 17-2, Page 17-3**). When the vehicle is on a level surface, use the upper plug as a lubricant level indicator. Lubricant level should be even with the bottom of level indicator hole. Use the lower plug for draining. **See following NOTE.**

**NOTE:** Observe the following for transaxles equipped with a limited-slip differential:

- Uses a magnetic drain plug.
- Unlike most limited-slip differentials, this unit **does not** use a friction modifier added to the gear oil.

### **Oil Change – Transaxle**

1. When draining transaxle oil, remove both plugs to allow the oil to drain faster.
2. Clean and reinstall the drain plug and gasket before filling the transaxle with new lubricant. Tighten drain plug to 17 ft·lb (23 N·m).
3. Use a funnel when filling the transaxle through the lubricant level indicator hole. Fill with 67.6 fl-oz (2 L) 80-90 WT. API class GL or 80-90 WT. AGMA class 5 EP gear lubricant (or until lubricant begins to run out of the level indicator hole).
4. Install upper plug and gasket and tighten to 17 ft·lb (23 N·m).

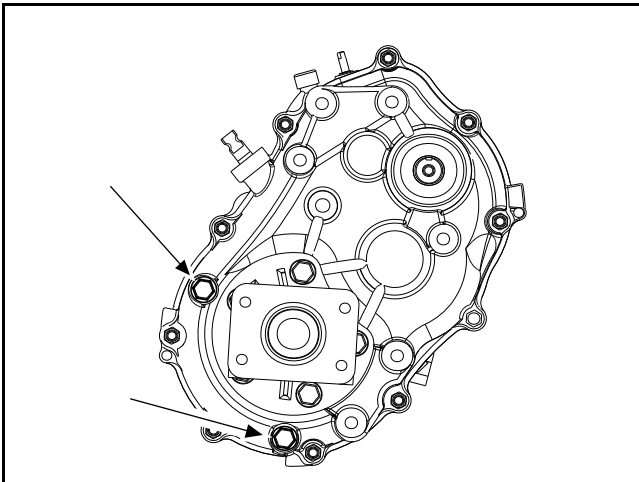

3055

**Figure 17-2 Lubricant Level Plug and Drain Plug**

## TOOLS REQUIRED FOR THIS SECTION

Hydraulic floor jack (or chain hoist)	Torque wrench, 3/8-in. drive	1/2-in. combination wrench
Jack stands (2) (one ton capacity)	3/8-in. socket, 3/8-in. drive	9/16-in. combination wrench
Standard slip joint pliers	7/16-in. socket, 3/8-in. drive	Small flat blade screwdriver
External snap ring pliers (.047- in. tip)	1/2-in. socket, 3/8-in. drive	Medium flat blade screwdrivers (2)
90° Internal snap ring pliers (0.090-in. tip)	9/16-in. socket, 3/8-in. drive	No. 2 phillips-head screwdriver
16-in. rolling head prybar	5/8-in. socket, 3/8- in. drive	1/4-in. nut driver
Plastic or rubber mallet	Axle seal tool	5/16-in. nut driver
Ratchet wrench, 3/8-in. drive	7/16-in. combination wrench	

## REAR HUBS

### REAR HUB REMOVAL

1. Turn the key switch to the OFF position and remove the key, and place the Forward/Neutral/Reverse control (FNR) in the NEUTRAL position.
2. Disconnect battery and spark plug wire. **See Disconnecting the Battery-Gasoline Vehicles on page 1-3.**
3. Place chocks at the front wheels and loosen lug nuts on both rear wheels.
4. Remove the rubber dust cap (1).
5. Remove and discard the cotter pin (2) (**Figure 17-3, Page 17-4**).
6. Remove nut locking cap (3) and loosen the hub nut (4) on the axle shaft.
7. Lift and support the rear of vehicle.
8. Remove the lug nuts and wheel.
9. Slide brake drum off hub.
10. Remove hub nut (4) and large flat washer (5) and pull hub (6) off axle shaft. **See following NOTE.**

**NOTE:** If the hub (6) does not slide easily off the axle shaft, use a two or four-jaw wheel puller to remove the hub.

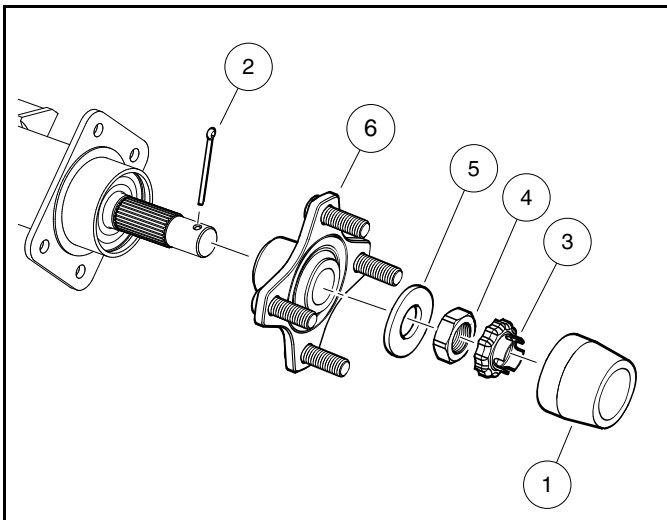

3056

Figure 17-3 Rear Hub Exploded View

### REAR HUB INSTALLATION

1. Inspect brake shoes for wear and replace if necessary. **See Wheel Brake Assemblies section.**

**NOTE:** If brake shoes are replaced on one side, replace the opposite side also.

2. Clean the splines and threaded portion of the axle shaft.
3. Apply anti-seize compound to both the axle shaft splines and hub (6) splines. **See following CAUTION.**



## CAUTION

- Do not allow anti-seize compound to contact the brake drum or shoes.
4. Slide hub (6) onto axle shaft (**Figure 17-3, Page 17-4**).
  5. Install the large flat washer (5) onto the threaded portion of the axle.
  6. Install hub nut (4) and advance the nut to the large flat washer.
  7. Install brake drum onto hub.
  8. Install the tire and wheel and finger-tighten the lug nuts.
  9. Lower the rear of the vehicle.
  10. Tighten the hub nut (4) to 147 ft·lb (200 N·m) initially. If possible, position the locking cap (3) on hub nut (4) and install new cotter pin (2). If necessary, tighten hub nut (4) further (177 ft·lb (240 N·m) max.) until the locking cap (3) and new cotter pin (2) can be installed.
  11. Deform cotter pin (2) as shown (**Figure 17-4, Page 17-5**). Either way is acceptable. No part of the cotter pin (2) should protrude beyond the perimeter of the locking cap (3).
  12. Install rubber dust cap (1).
  13. Tighten lug nuts to 65 ft·lb (88 N·m) using a crisscross pattern.
  14. Connect battery and spark plug wire.

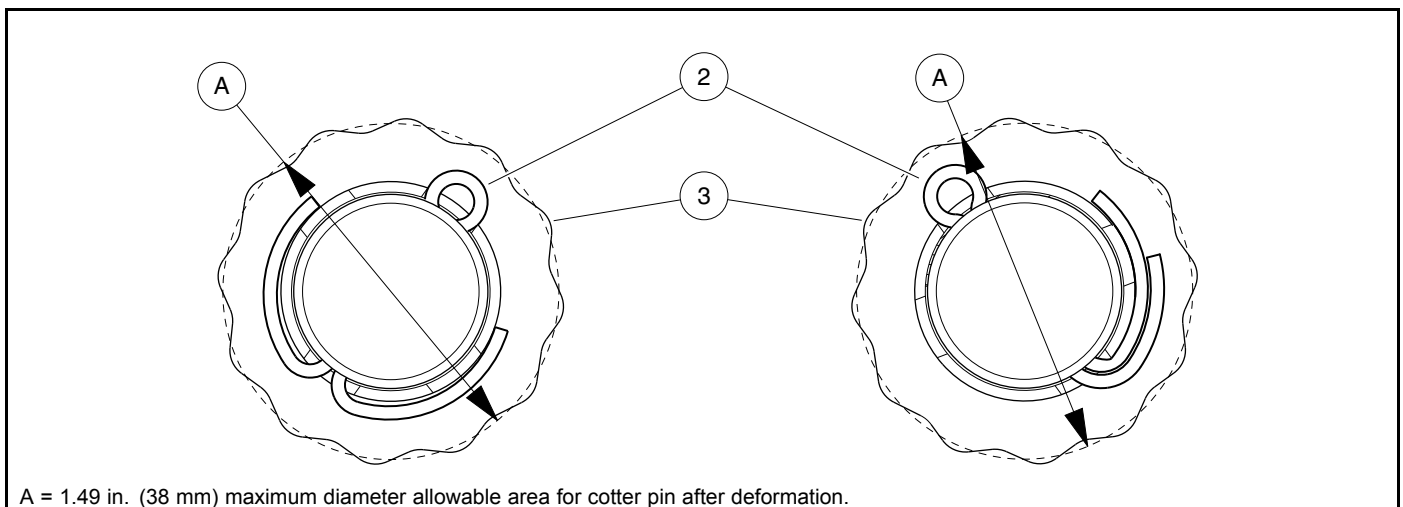

3057

**Figure 17-4 Cotter Pin Deformation**

## AXLE TUBES, AXLE SHAFTS AND WHEEL BEARINGS

Removal of the transaxle is not required for servicing or replacing axle shafts, axle bearings, or axle shaft oil seals. If the transaxle is to be removed from the vehicle, do not remove the wheels, axle shafts, or axle tubes first. Instructions for removing the transaxle from the vehicle begin on page 17-9.

**NOTE:** The axle shaft oil seals (7) are located in the transaxle gearcase (4), not the axle tubes (2) (Figure 17-5, Page 17-6). The axle tubes must be removed in order to replace these oil seals.

### AXLE TUBE AND AXLE SHAFT REMOVAL

See General Warnings, Section 1, Page 1-1.

The transaxle has two axle shafts. If only a tube or shaft is to be serviced, it can be done one side at a time without removing the transaxle.

1. Clean debris from drain plug and area around it at the bottom of the transaxle. Drain oil. Install plug after draining.
2. If removing entire transaxle from vehicle, remove the transaxle and clean it in preparation for disassembly. **See Transaxle Removal on page 17-9. See following NOTE.**

**NOTE:** After cleaning, move transaxle to a clean location before disassembly.

3. If removing only one axle tube or shaft from vehicle, clean that tube and hub in preparation for disassembly.
4. Remove hub. **See Rear Hub Removal on page 17-4.**
5. Remove the five flange-head bolts (1) securing axle tube (2) to transaxle (Figure 17-5, Page 17-6).
6. Avoiding damage caused by dragging splines across lip of oil seal (7) in transaxle gearcase, carefully pull axle tube (2) and shaft (3) from transaxle.

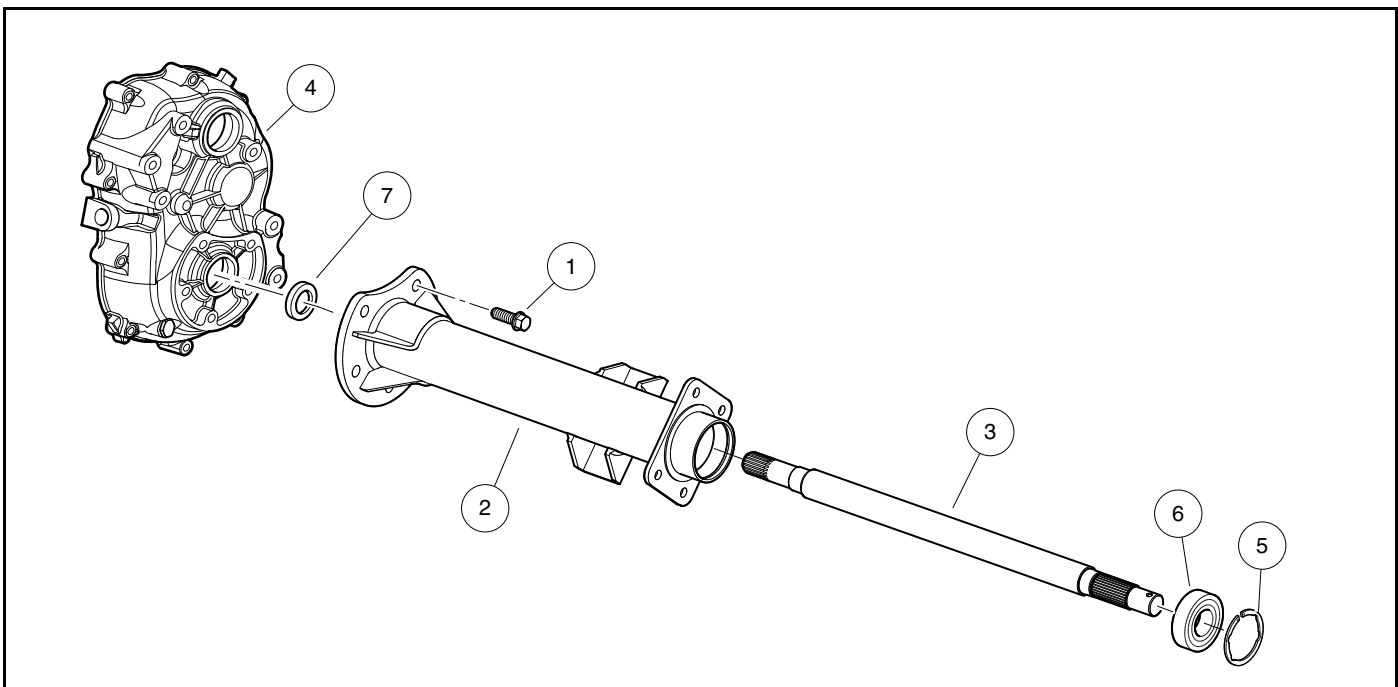

3058

Figure 17-5 Axle Tube, Shaft, Bearing and Oil Seal

## AXLE TUBE AND AXLE SHAFT INSTALLATION

1. Clean mating surfaces of axle tube (2) flange and transaxle gearcase (4). Also clean the threads of the five axle tube mounting holes in the gearcase. **See following CAUTION.**

### **CAUTION**

- **If necessary, clean each mounting hole with a thread tap (M10 x 1.25 pitch) before installing flange bolts.**
2. Clean and lubricate the oil seal (7) in the transaxle gearcase (4) with oil (**Figure 17-5, Page 17-6**).
  3. Clean inner end of axle shaft (3). Avoiding damage caused by dragging splines across lip of oil seal (7) in transaxle gearcase (4), carefully install axle shaft (3) and tube (2). **See following NOTE.**

**NOTE:** *It may be necessary to rotate each shaft (3) slightly to engage the splines in the differential.*

4. Secure axle tube (2) to gearcase (4) with flange bolts (1). Use a crisscross pattern to tighten flange bolts to 28 ft·lb (38 N·m).
5. Install hub. **See Rear Hub Installation on page 17-4.**
6. If entire transaxle was removed from vehicle, install transaxle. **See Transaxle Installation on page 17-13.**
7. Refill transaxle with appropriate type and volume of oil. **See Oil Change – Transaxle on page 17-2.**

## REAR WHEEL BEARING REMOVAL

1. Remove hub. **See Rear Hub Removal on page 17-4.**
2. Remove axle tube (2) from transaxle. **See Axle Tube and Axle Shaft Removal on page 17-6.**
3. Remove the snap ring (5) that is in front of the bearing (6) and discard (**Figure 17-5, Page 17-6**).
4. Drive axle shaft (3) and bearing (6) from outer end of axle tube (2) as an assembly.
5. Use a puller to remove bearing (6) from axle shaft (3). **See following CAUTION.**

### **CAUTION**

- **To prevent damaging the threads on end of axle shaft (3), install hub nut to cover initial threads prior to using puller.**

## REAR WHEEL BEARING INSTALLATION

1. Press new bearing (6) onto axle shaft (3) until fully seated.
2. Clean inside axle tube (2) where new bearing (6) will sit and lightly lubricate the bore (**Figure 17-5, Page 17-6**).
3. Using an appropriate sized bearing driver that fits the outer race, drive in bearing/shaft assembly (3 and 6) until fully seated in tube (2).
4. Install new snap ring (5).
5. Install axle tube (2). **See Axle Tube and Axle Shaft Installation on page 17-7.**
6. Install hub. **See Rear Hub Installation on page 17-4.**

## AXLE SHAFT OIL SEAL REMOVAL

The rear axle tubes (2) must be unbolted from the transaxle to replace oil seals (7) (**Figure 17-5, Page 17-6**).

1. Clean debris from drain plug and area around it at the bottom of the transaxle. Drain oil. Install plug after draining.

2. Remove axle tube (2) from gearcase (4) (**Figure 17-5, Page 17-6**). See **Axle Tube and Axle Shaft Removal on page 17-6**.
3. Pull oil seal (7) from gearcase (4).

### AXLE SHAFT OIL SEAL INSTALLATION

1. Clean bore in gearcase (4) where new oil seal (7) will sit (**Figure 17-5, Page 17-6**).
2. Using an appropriate sized seal driver, drive in new oil seal (7) until 0.0393 in. (1 mm) below surface, not fully seated.
3. Clean end of axle shaft (3) and carefully install axle tube (2) to avoid damaging new oil seal (7) with splines of axle shaft. See **Axle Tube and Axle Shaft Installation on page 17-7**.
4. Refill transaxle with appropriate type and volume of oil. See **Oil Change – Transaxle on page 17-2**.

## TRANSAXLE REMOVAL

See General Warnings on page 1-1.

1. Turn the key switch to the OFF position and remove the key, and place the Forward/Neutral/Reverse control (FNR) in the NEUTRAL position.
2. Disconnect battery and spark plug wire. **See Disconnecting the Battery-Gasoline Vehicles on page 1-3.**
3. Place chocks at the front wheels and loosen lug nuts on both rear wheels.
4. Disconnect air intake hose, vent hose, and fuel line from throttle body and accelerator cable from electrical component box. **See Fuel System, Section 14, Page 14-1.**
5. Disconnect gray 18-pin connector from ECU.
6. Disconnect braided ground cable from engine (**Figure 11-3, Page 11-12**).
7. **Pedal-Start Vehicles Only:** Disconnect 3-wire plug from limit switch on transaxle.
8. Disconnect three wires of main wire harness from starter/generator .
9. Loosen jam nuts (1) securing shifter cable (2) to FNR/accelerator cable mounting bracket. Then, remove bowtie clip (3) to disconnect shifter cable end (4) from transaxle shift lever (5) and set shifter cable (2) aside (**Figure 17-14, Page 17-14**).
10. Remove bolts (1) securing governor cable bracket (2) and FNR/accelerator cable bracket (3) to transaxle (**Figure 17-6, Page 17-9**). Do not disconnect cables (4 and 5).
11. Unhook governor cable (4) and accelerator cable (5) from the governor arm (7).

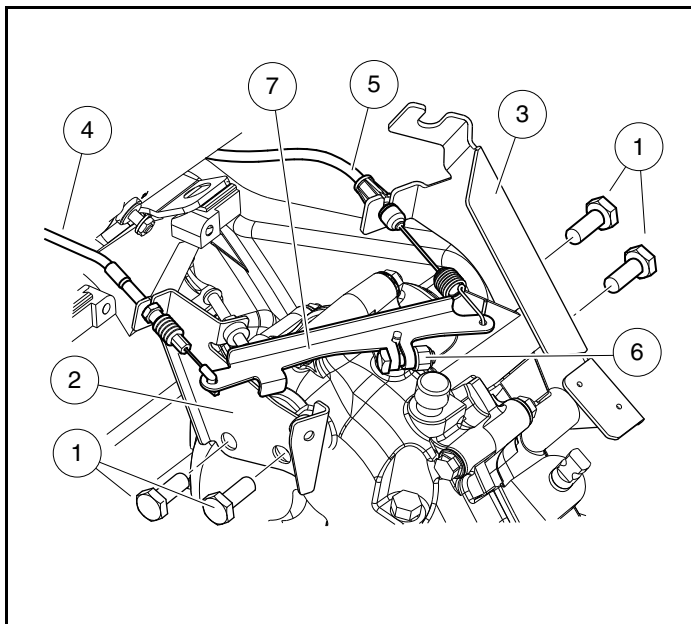

3059

**Figure 17-6 Governor Arm, Cable and Brackets**

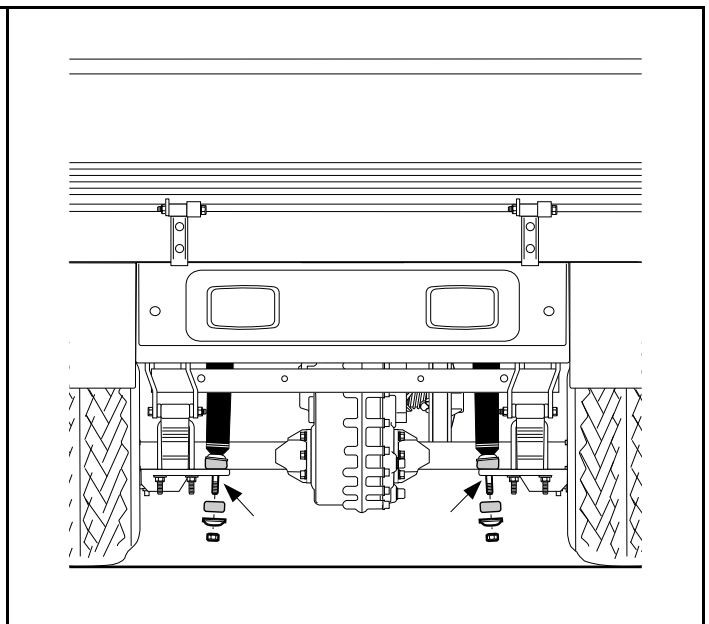

3060

**Figure 17-7 Disconnect Shock Absorbers**

12. Disconnect brake cables from brake assemblies. **See Wheel Brake Assemblies section.**
13. Remove lower shock mounting hardware from both rear shocks (**Figure 17-7, Page 17-9**).

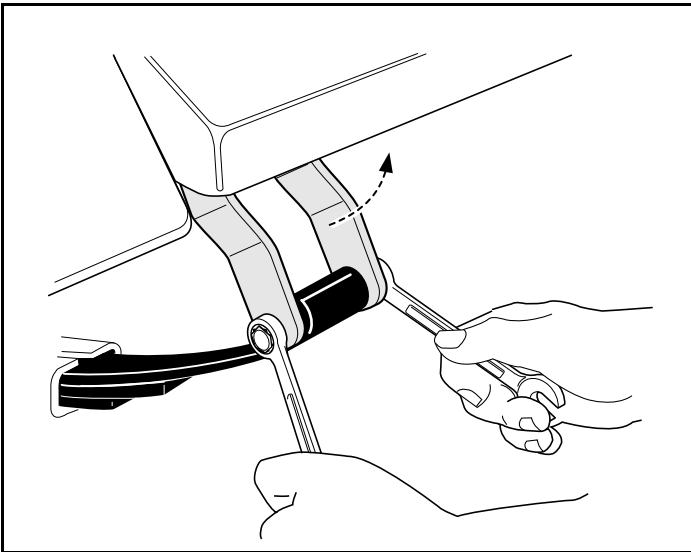

838

Figure 17-8 Disconnect Rear Shackles

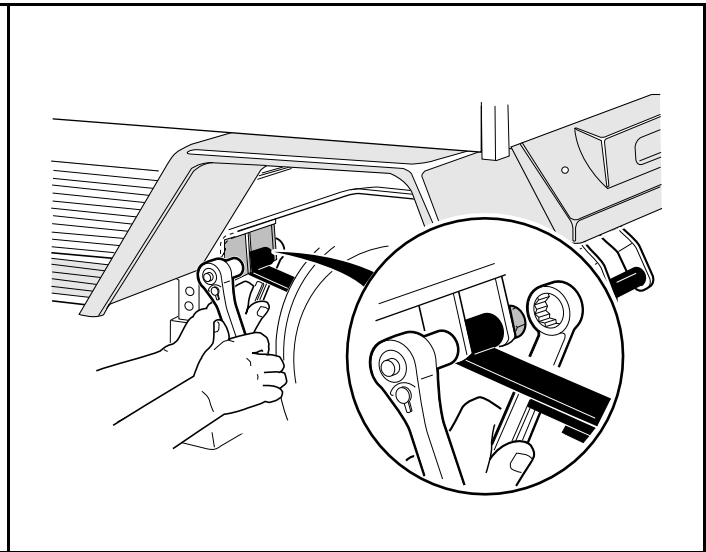

839

Figure 17-9 Disconnect Front of Leaf Spring

14. Position floor jack under rear crossmember of chassis or trailer hitch mount (if equipped) (**Figure 17-10, Page 17-10**). **See WARNING “Lift only one end of the vehicle...” in General Warnings on page 1-1.**
15. Raise vehicle just enough to relieve weight on leaf springs, then remove bolts securing leaf springs to shackles (**Figure 17-8, Page 17-10**).
16. Remove bolts securing front of leaf springs (**Figure 17-9, Page 17-10**).

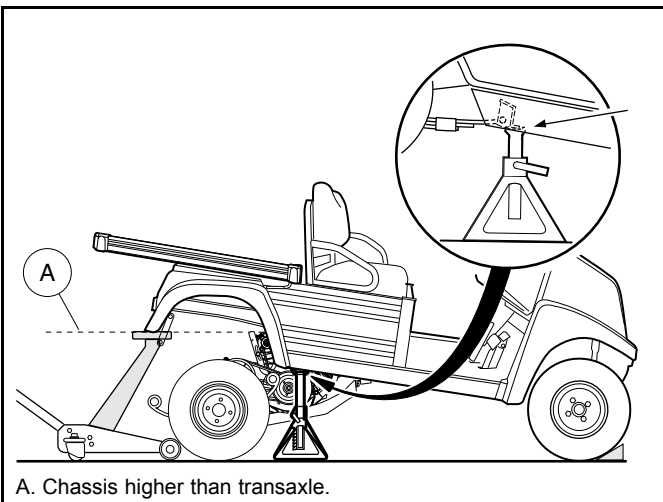

3061

Figure 17-10 Raise Vehicle and Support On Jack Stands

17. Continue raising vehicle until chassis is higher than the top of the transaxle (i.e. enough to allow powertrain to be rolled out from under vehicle) (**Figure 17-10, Page 17-10**). Position jack stands, adjusted to support the vehicle at this height, under the frame crossmember between the leaf spring mounts and side stringers, just forward of each rear wheel. Lower the floor jack to allow the jack stands to support the vehicle.
18. Remove floor jack from beneath vehicle.
19. Grasp ends of leaf springs at rear of vehicle and carefully pull the powertrain until snubber at front of engine pan is free of the chassis. Gently lower front of powertrain to the floor (**Figure 17-11, Page 17-11**). The powertrain should be completely disconnected from vehicle and resting on floor.

20. Roll powertrain out from under vehicle.
21. Place blocks under the engine pan so they will completely support the engine and keep it **level to the floor** (Figure 17-11, Page 17-11). See following NOTE.

**NOTE:** Place the blocks so they will support the engine when the transaxle is detached and moved away from the powertrain.

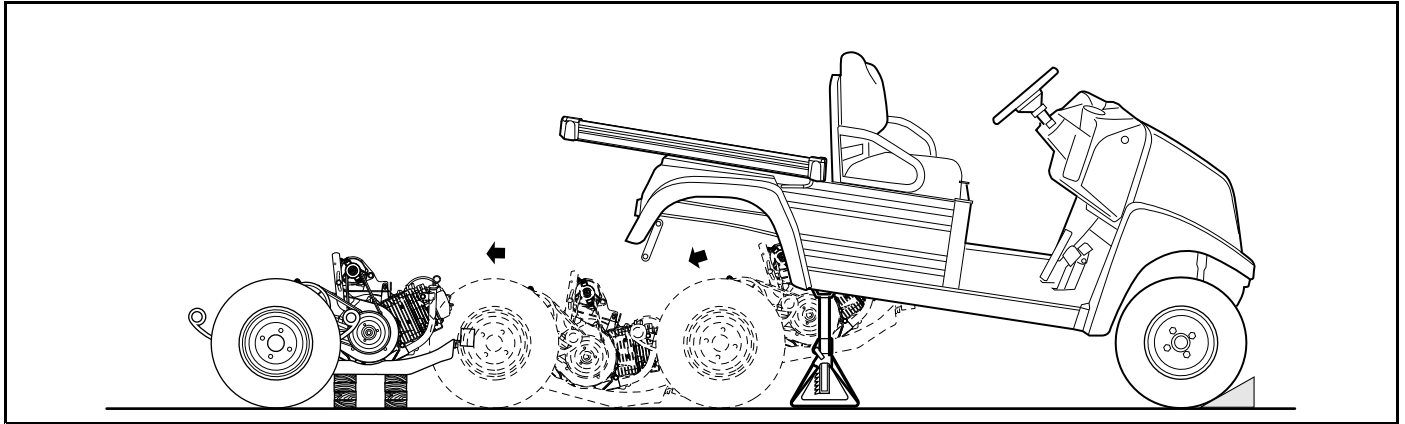

3062

**Figure 17-11 Remove Powertrain and Place Wood Blocks Under Engine Pan**

22. Remove oil drain plug and drain all oil from transaxle. Dispose of gear oil properly.
23. Remove driven clutch. See **Driven Clutch Removal, Section 16, Page 16-13**.
24. Remove eight bolts (1) total that secure transaxle to powertrain (Figure 17-12, Page 17-12) at the following locations:
  - Four bolts (1) at engine pan (2).
  - Two bolts (1) at clutch plate (3).
  - Two bolts (1) at muffler bracket.
25. Roll transaxle from engine pan (2). See following NOTE.

**NOTE:** The transaxle weighs approximately 58 lb (26.2 kg).

26. If replacing transaxle, remove leaf springs, wheels, hubs and brake assemblies and retain for installation on new transaxle. See **Rear Suspension section**. See **Wheel Brake Assemblies section**.

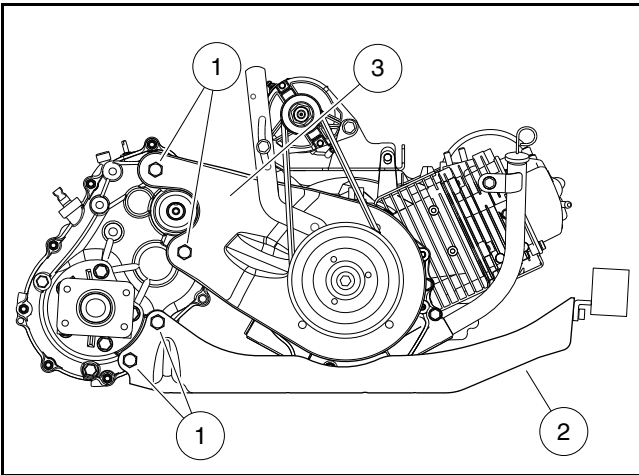

3063

**Figure 17-12 Transaxle Mounting Bolts**



## TRANSAXLE INSTALLATION

---

See General Warnings on page 1-1.

1. Installation is reverse of removal procedure. When attaching transaxle to powertrain, initially install the eight bolts (1) finger-tight (**Figure 17-12, Page 17-12**). Then, tighten fasteners in the following order:
  - 1.1. Tighten the two bolts (1) at clutch plate (3) to 50 ft·lb (68 N·m).
  - 1.2. Tighten the four bolts (1) at engine pan (2) to 50 ft·lb (68 N·m).
  - 1.3. Tighten the two bolts (1) at muffler bracket to 50 ft·lb (68 N·m).
  - 1.4. Tighten the governor cable bracket (2) and FNR/accelerator cable bracket (2) bolts to 50 ft·lb (68 N·m) (**Figure 17-6, Page 17-9**).
  - 1.5. Tighten leaf spring hardware to 19 ft·lb (26 N·m) at chassis and shackle. **See Rear Suspension section.**
  - 1.6. Tighten lower nuts of shock absorbers until cushions expand to be the same diameter as the mounting washers.
  - 1.7. Tighten transaxle drain plug to 17 ft·lb (23.5 N·m).
2. Fill transaxle with appropriate type and volume of oil. **See Oil Change – Transaxle on page 17-2.**
3. Ensure that all wires and cables are secured properly with wire ties. **See following WARNING.**

### **⚠ WARNING**

- **If wires and cables are removed or replaced make sure they are properly routed and secured to vehicle frame. Failure to properly route and secure wires and cables could result in vehicle malfunction, property damage or personal injury.**
4. Connect battery and spark plug wire. **See Connecting the Battery-Gasoline Vehicles on page 1-3.**
  5. Check governor adjustment and correct if necessary. **See Governor Cable Installation and Adjustment, Section 14, Page 14-6.**
  6. Check engine RPM setting. Adjust if necessary. **See Engine RPM Adjustment, Section 14, Page 14-10.**

## SHIFTER CABLE

---

See General Warnings on page 1-1.

If the Forward/Neutral/Reverse control (FNR) cable is damaged in any way, it must be replaced.

### SHIFTER CABLE REMOVAL

**NOTE:** Before removing cable, note cable routing and positions of wire ties or other devices securing the cable to the vehicle. When installed, cable must be routed and secured as it was originally.

1. Turn the key switch to the OFF position and remove the key. Place the Forward/Neutral/Reverse control (FNR) in the NEUTRAL position and chock the wheels.
2. Disconnect battery and spark plug wire. **See Disconnecting the Battery-Gasoline Vehicles on page 1-3.**
3. Push the cable end socket (1) off the stud (3) on the Forward/Neutral/Reverse control (FNR) handle (**Figure 17-13, Page 17-14**).
4. Press in tangs (4) anchoring shifter cable (2) to chassis and push out of mounting hole.

5. Loosen jam nuts (1) securing shifter cable (2) to FNR/accelerator cable bracket (3) (**Figure 17-14, Page 17-14**). Then, remove bowtie clip (3) to disconnect shifter cable end (4) from transaxle shift lever (5).
6. Cut wire ties securing shifter cable to chassis.
7. Make note of cable routing, then remove shifter cable from vehicle.

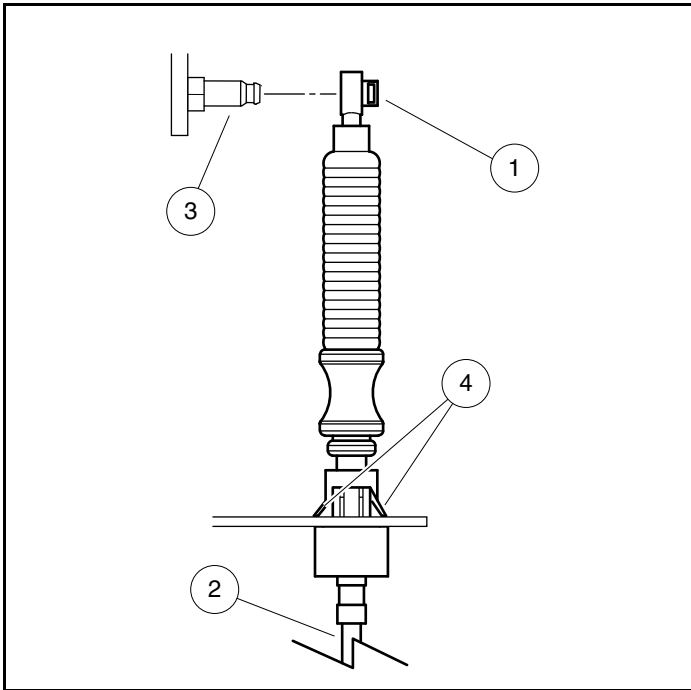

3064

Figure 17-13 Shifter Cable at FNR Handle

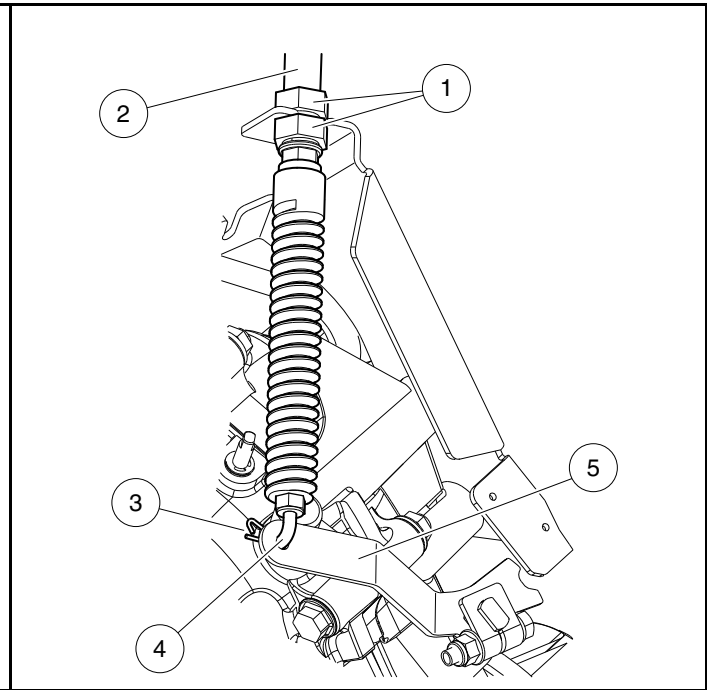

3065

Figure 17-14 Shifter Cable at Transaxle

## SHIFTER CABLE INSTALLATION

1. Install shifter cable (2), routing it exactly as it was originally, from instrument panel to transaxle.
2. Place rear of cable (2) in FNR/accelerator cable bracket with a jam nut (1) on each side of bracket (**Figure 17-14, Page 17-14**). Tighten jam nuts (1) to 22 ft·lb (29.8 N·m).
3. Hook shifter cable end (4) into transaxle shift lever (5) and secure with bowtie clip (3).
4. Feed front of cable (2) through its mounting hole and push the plastic anchor into hole until tangs (4) snap into place (**Figure 17-13, Page 17-14**).
5. Snap cable end socket (1) onto stud (3) of Forward/Reverse shifter handle.
6. Secure shifter cable along chassis with wire ties.
7. Connect battery and spark plug wire. **See Connecting the Battery-Gasoline Vehicles on page 1-3.**

## SHIFTER CABLE ADJUSTMENT

Cable is properly adjusted when both the Forward/Neutral/Reverse control (FNR) at instrument panel and shift lever on transaxle are in the NEUTRAL position at the same time.

To adjust, the jam nuts (6) at the FNR/accelerator cable bracket must be loosened and moved forward or backward as required (**Figure 17-14, Page 17-14**). Tighten jam nuts (6) to 22 ft·lb (29.8 N·m).



# KOHLER® Command PRO

ECH440 for CLUB CAR

Service Manual

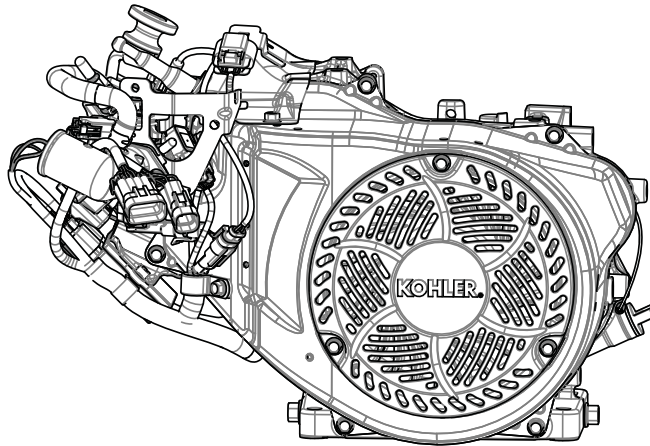

---

**IMPORTANT:** Read all safety precautions and instructions carefully before operating equipment. Refer to operating instruction of equipment that this engine powers.

Ensure engine is stopped and level before performing any maintenance or service.

---

---

2	Safety
3	Maintenance
5	Specifications
16	Tools and Aids
19	Troubleshooting
23	Air Cleaner/Intake (OEM Supplied)
24	Electronic Fuel Injection (EFI) System
51	Governor System (OEM Supplied)
52	Lubrication System
54	Electrical System
57	Starter System (OEM Supplied)
58	Disassembly/Inspection and Service
70	Reassembly

---

# Safety

## SAFETY PRECAUTIONS

**⚠ WARNING:** A hazard that could result in death, serious injury, or substantial property damage.

**⚠ CAUTION:** A hazard that could result in minor personal injury or property damage.

NOTE: is used to notify people of important installation, operation, or maintenance information.

	<b>⚠ WARNING</b>
	Explosive Fuel can cause fires and severe burns. Do not fill fuel tank while engine is hot or running.
Gasoline is extremely flammable and its vapors can explode if ignited. Store gasoline only in approved containers, in well ventilated, unoccupied buildings, away from sparks or flames. Spilled fuel could ignite if it comes in contact with hot parts or sparks from ignition. Never use gasoline as a cleaning agent.	

	<b>⚠ WARNING</b>
	Rotating Parts can cause severe injury. Stay away while engine is in operation.
Keep hands, feet, hair, and clothing away from all moving parts to prevent injury. Never operate engine with covers, shrouds, or guards removed.	

	<b>⚠ WARNING</b>
	Carbon Monoxide can cause severe nausea, fainting or death. Avoid inhaling exhaust fumes.
Engine exhaust gases contain poisonous carbon monoxide. Carbon monoxide is odorless, colorless, and can cause death if inhaled.	

	<b>⚠ WARNING</b>
	Accidental Starts can cause severe injury or death. Disconnect and ground spark plug lead(s) before servicing.
Before working on engine or equipment, disable engine as follows: 1) Disconnect spark plug lead(s). 2) Disconnect negative (-) battery cable from battery.	

	<b>⚠ WARNING</b>
	Hot Parts can cause severe burns. Do not touch engine while operating or just after stopping.
Never operate engine with heat shields or guards removed.	

	<b>⚠ WARNING</b>
	Cleaning Solvents can cause severe injury or death. Use only in well ventilated areas away from ignition sources.
Carburetor cleaners and solvents are extremely flammable. Follow cleaner manufacturer's warnings and instructions on its proper and safe use. Never use gasoline as a cleaning agent.	



	<b>⚠ WARNING</b>
	High Pressure Fluids can puncture skin and cause severe injury or death. Do not work on fuel system without proper training or safety equipment.
Fluid puncture injuries are highly toxic and hazardous. If an injury occurs, seek immediate medical attention.	

	<b>⚠ CAUTION</b>
	Electrical Shock can cause injury. Do not touch wires while engine is running.

	<b>⚠ CAUTION</b>
	Damaging Crankshaft and Flywheel can cause personal injury.
Using improper procedures can lead to broken fragments. Broken fragments could be thrown from engine. Always observe and use precautions and procedures when installing flywheel.	

	<b>⚠ CAUTION</b>
	Failure to utilize or reassemble debris screen as designed could result in debris screen failure and serious personal injury.

## MAINTENANCE INSTRUCTIONS

	 <b>WARNING</b>	Before working on engine or equipment, disable engine as follows: 1) Disconnect spark plug lead(s). 2) Disconnect negative (-) battery cable from battery.
	Accidental Starts can cause severe injury or death. Disconnect and ground spark plug lead(s) before servicing.	

Normal maintenance, replacement or repair of emission control devices and systems may be performed by any repair establishment or individual; however, warranty repairs must be performed by a Kohler authorized dealer.

## MAINTENANCE SCHEDULE

After first 100 Hours<sup>3</sup>

<ul style="list-style-type: none"> <li>Change oil.</li> </ul>	Lubrication System
---	--------------------

Every 100 Hours<sup>1</sup>

<ul style="list-style-type: none"> <li>Check air cleaner element; replace as necessary (OEM supplied air cleaner).</li> </ul>	Refer to equipment manual
---	---------------------------

Every 100 Hours or Annually<sup>1</sup>

<ul style="list-style-type: none"> <li>Clean cooling areas.</li> </ul>	Air Cleaner/Intake
--	--------------------

Every 200 Hours<sup>3</sup>

<ul style="list-style-type: none"> <li>Change oil.</li> </ul>	Lubrication System
---	--------------------

Every 300 Hours

<ul style="list-style-type: none"> <li>Check fuel filters (tank outlet filter and in-line filter) clean or replace if needed (OEM supplied if equipped).</li> </ul>	Refer to equipment manual
---	---------------------------

Every 300 Hours<sup>1</sup>

<ul style="list-style-type: none"> <li>Replace unique Electronic Fuel Injection (EFI) fuel filter (OEM supplied if equipped).</li> </ul>	Refer to equipment manual
--	---------------------------

Every 300 Hours<sup>2</sup>

<ul style="list-style-type: none"> <li>Check and adjust valve clearance when engine is cold.</li> </ul>	Reassembly
---	------------

Every 500 Hours or Annually<sup>1</sup>

<ul style="list-style-type: none"> <li>Replace spark plug and set gap.</li> </ul>	Electrical System
---	-------------------

<sup>1</sup> Perform these procedures more frequently under severe, dusty, dirty conditions.

<sup>2</sup> Have a Kohler authorized dealer perform this service.

<sup>3</sup> If engine is frequently used for short periods of time in ambient temperatures below 4°C (40°F), reduce oil change intervals to every 25 hours. Refer to Winter Lubrication details in Lubrication System.

## REPAIRS/SERVICE PARTS

Kohler genuine service parts can be purchased from Kohler authorized dealers. To find a local Kohler authorized dealer visit [KohlerEngines.com](http://KohlerEngines.com) or call 1-800-544-2444 (U.S. and Canada).

# Maintenance

## OIL RECOMMENDATIONS

We recommend use of Kohler oils for best performance. Other high-quality detergent oils (including synthetic) of API (American Petroleum Institute) service class SJ or higher are acceptable. Select viscosity based on air temperature at time of operation as shown in table below.

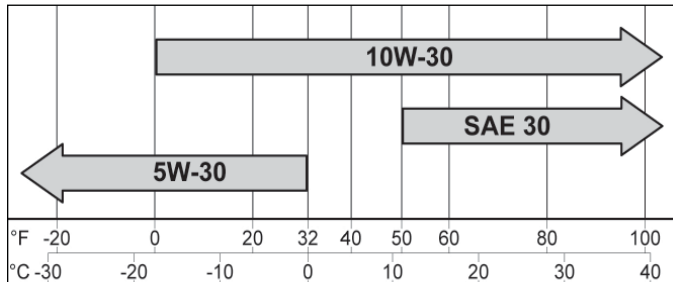

## FUEL RECOMMENDATIONS

	<b>⚠ WARNING</b>
	Explosive Fuel can cause fires and severe burns. Do not fill fuel tank while engine is hot or running.
Gasoline is extremely flammable and its vapors can explode if ignited. Store gasoline only in approved containers, in well ventilated, unoccupied buildings, away from sparks or flames. Spilled fuel could ignite if it comes in contact with hot parts or sparks from ignition. Never use gasoline as a cleaning agent.	

NOTE: E15, E20 and E85 are NOT approved and should NOT be used; effects of old, stale or contaminated fuel are not warrantable.

Fuel must meet these requirements:

- Clean, fresh, unleaded gasoline.
- Octane rating of 87 (R+M)/2 or higher.
- Research Octane Number (RON) 90 octane minimum.
- Gasoline up to 10% ethyl alcohol, 90% unleaded is acceptable.
- Methyl Tertiary Butyl Ether (MTBE) and unleaded gasoline blend (max 15% MTBE by volume) are approved.
- Do not add oil to gasoline.
- Do not overfill fuel tank.
- Do not use gasoline older than 30 days.

## STORAGE

If engine will be out of service for 2 months or more follow procedure below.

1. Add Kohler PRO Series fuel treatment or equivalent to fuel tank. Run engine 2-3 minutes to get stabilized fuel into fuel system (failures due to untreated fuel are not warrantable).
2. Change oil while engine is still warm from operation. Remove spark plug(s) and pour about 1 oz. of engine oil into cylinder(s). Replace spark plug(s) and crank engine slowly to distribute oil.
3. Disconnect negative (-) battery cable.
4. Store engine in a clean, dry place.

Engine Dimensions-Flywheel Side

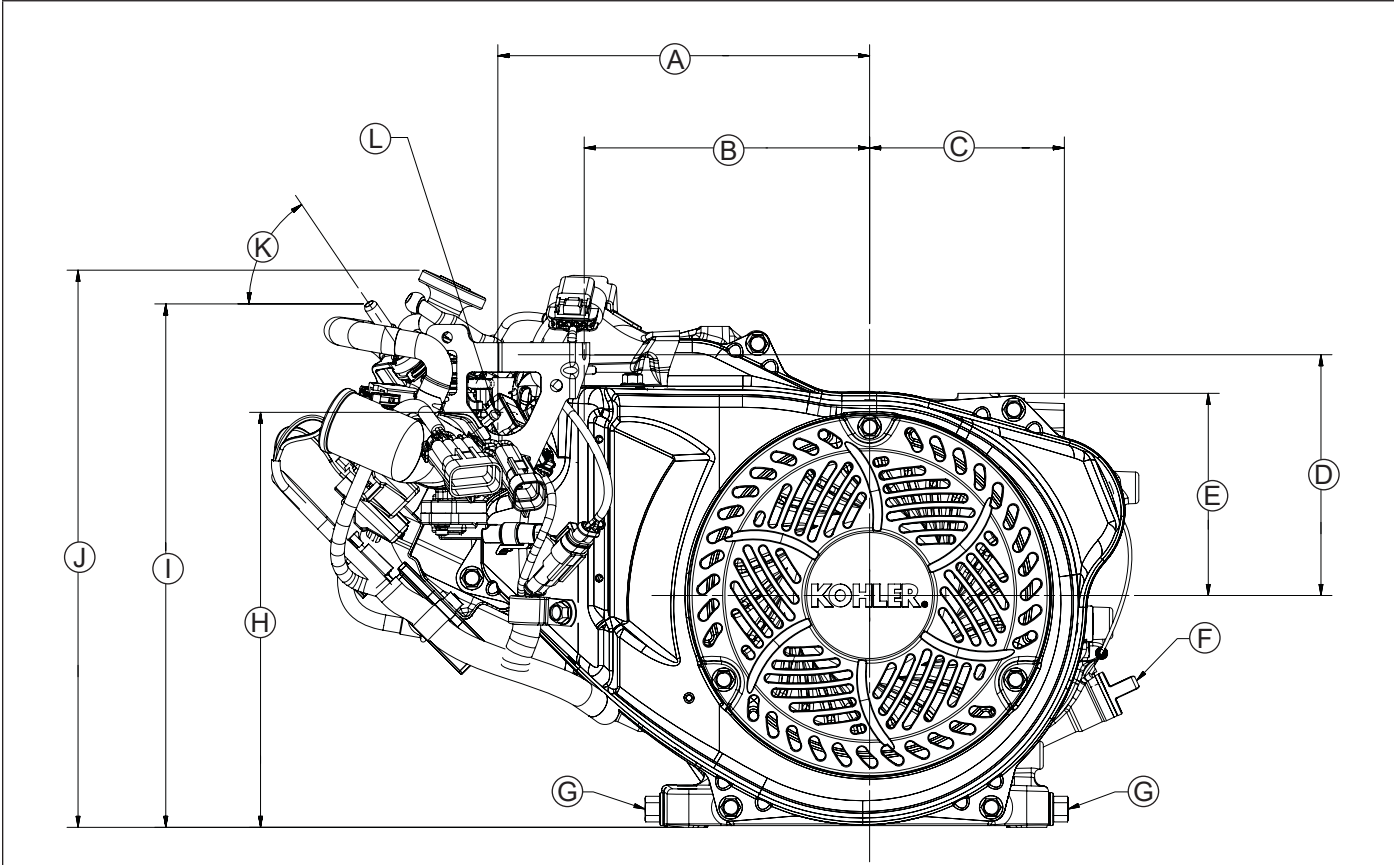

<b>A</b>	214.1 mm (8.43 in.) Throttle Body Evap Fitting	<b>B</b>	164.3 mm (6.47 in.) Throttle Cable Mount Face	<b>C</b>	2 X 112.1 mm (4.42 in.)	<b>D</b>	138.6 mm (5.46 in.) Throttle Cable Center Line
<b>E</b>	116.4 mm (4.58 in.)	<b>F</b>	Oil Fill Plug	<b>G</b>	Oil Drain Plug	<b>H</b>	239.0 mm (9.41 in.) Throttle Body Evap Fitting
<b>I</b>	301.4 mm (11.87 in.) Fuel Injector Cap	<b>J</b>	320.8 mm (12.63 in.)	<b>K</b>	55.9°	<b>L</b>	Throttle Body Evap Fitting



# Specifications

## Engine Dimensions-Top Side

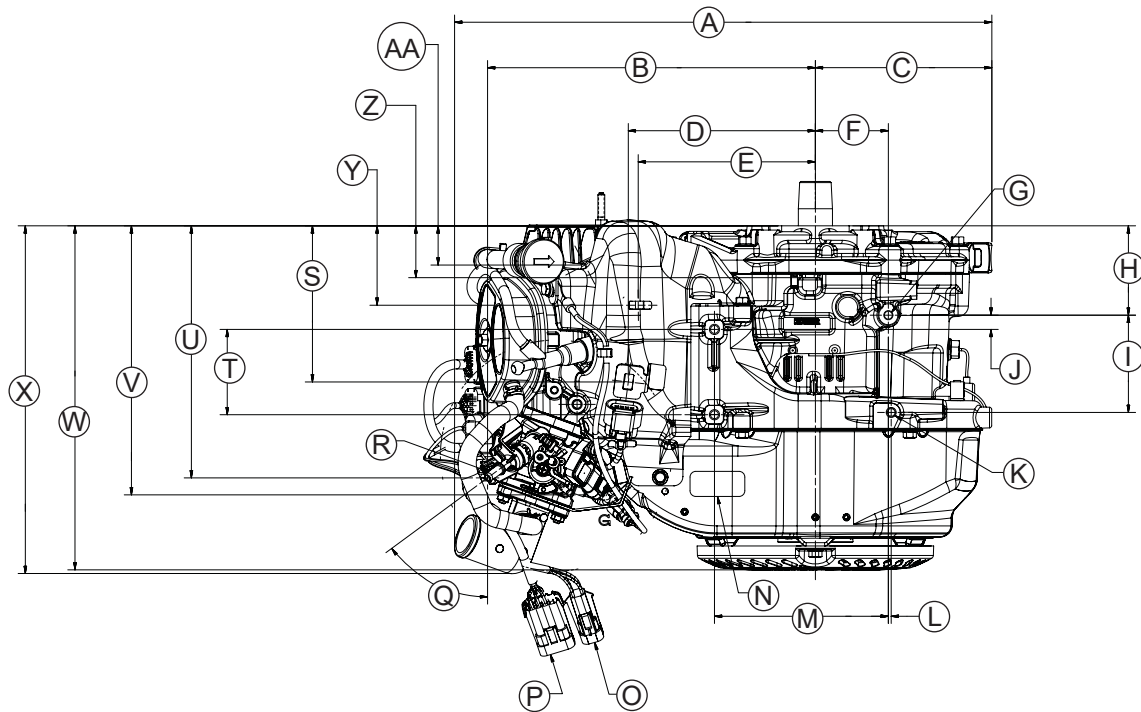

<b>A</b>	472.4 mm (18.60 in.)	<b>B</b>	288.2 mm (11.35 in.) Fuel Injector Cap	<b>C</b>	155.1 mm (6.11 in.)	<b>D</b>	164.5 mm (6.48 in.) Oxygen Sensor Bracket
<b>E</b>	155.8 mm (6.13 in.) Oxygen Sensor Harness Clip	<b>F</b>	64.1 mm (2.53 in.)	<b>G</b>	M8 X 1.25-6H Tap 19.0 mm (0.75 in.) Deep	<b>H</b>	78.6 mm (3.09 in.)
<b>I</b>	85.5 mm ± 0.36 mm (3.37 in. ± 0.01 in.)	<b>J</b>	12.5 mm ± 0.43 mm (0.49 in. ± 0.02 in.)	<b>K</b>	3 X M8 X 1.25-6H Tap Thru	<b>L</b>	2.5 mm ± 0.36 mm (0.10 in. ± 0.01 in.)
<b>M</b>	152.9 mm ± 0.43 mm (6.02 in. ± 0.02 in.)	<b>N</b>	Emission Label	<b>O</b>	Diagnostic Connector	<b>P</b>	8-Terminal Customer Connector
<b>Q</b>	53.7°	<b>R</b>	Fuel Injector Cap	<b>S</b>	137.3 mm (5.41 in.) Oxygen Sensor Bracket	<b>T</b>	75.0 mm ± 0.50 mm (3.0 in. ± 0.02 in.)
<b>U</b>	221.6 mm (8.73 in.) Fuel Injector Cap	<b>V</b>	236.5 mm (9.31 in.) Throttle Body Evap Fitting	<b>W</b>	302.5 mm (11.91 in.)	<b>X</b>	305.7 mm (12.04 in.)
<b>Y</b>	69.8 mm (2.75 in.) Oxygen Sensor Harness Clip	<b>Z</b>	45.6 mm (1.80 in.) Engine Lifting Hole Surface	<b>AA</b>	34.5 mm (1.36 in.) Exhaust Port		

## Engine Dimensions-PTO Side

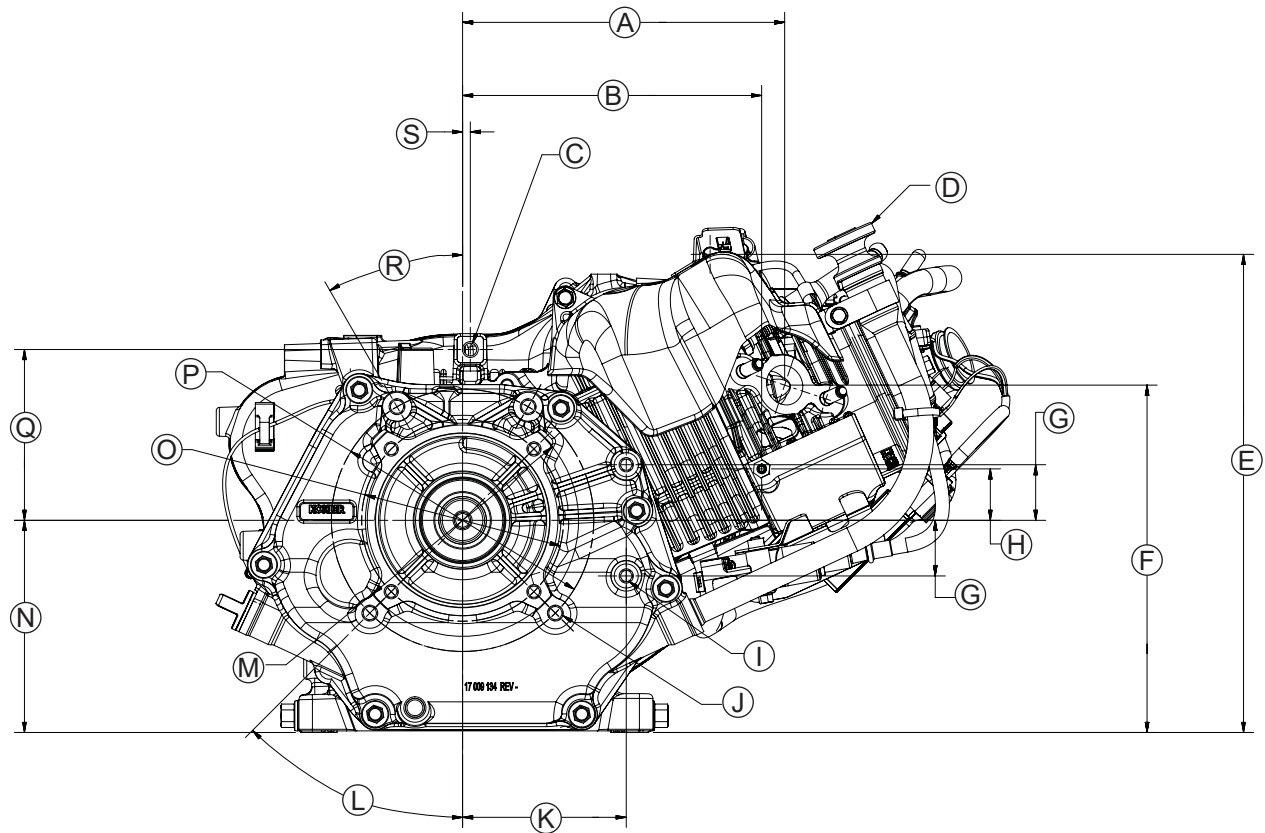

<b>A</b>	202.7 mm (7.98 in.) Exhaust Port	<b>B</b>	188.2 mm (7.41 in.)	<b>C</b>	6 X M8 X 1.25-6H 18.00 mm (0.71 in.) Deep	<b>D</b>	Dipstick and Oil Fill Tube
<b>E</b>	300.9 mm (11.85 in.) Oxygen Sensor Harness Clip	<b>F</b>	218.6 mm (8.61 in.) Exhaust Port	<b>G</b>	35.0 mm (1.38 in.)	<b>H</b>	32.4 mm (1.28 in.)
<b>I</b>	6 X 5/16-24 UNF TAP 18.0 mm (0.71 in.) Deep	<b>J</b>	4 X 3/8-16 UNC 2B TAP 20.0 mm (0.79 in.) Deep	<b>K</b>	2 X 103 mm (4.06 in.)	<b>L</b>	2 X 45°
<b>M</b>	Ø 146.0 mm (5.75 in.) Pilot	<b>N</b>	133.5 mm (5.26 in.)	<b>O</b>	Ø 127.0 mm (5.00 in.)	<b>P</b>	Ø 165.1 mm (6.50 in.)
<b>Q</b>	107.49 mm (4.23 in.)	<b>R</b>	2 X 30°	<b>S</b>	4.9 mm (0.19 in.)		

# Specifications

## Engine Dimensions-Opposite Cylinder Head Side

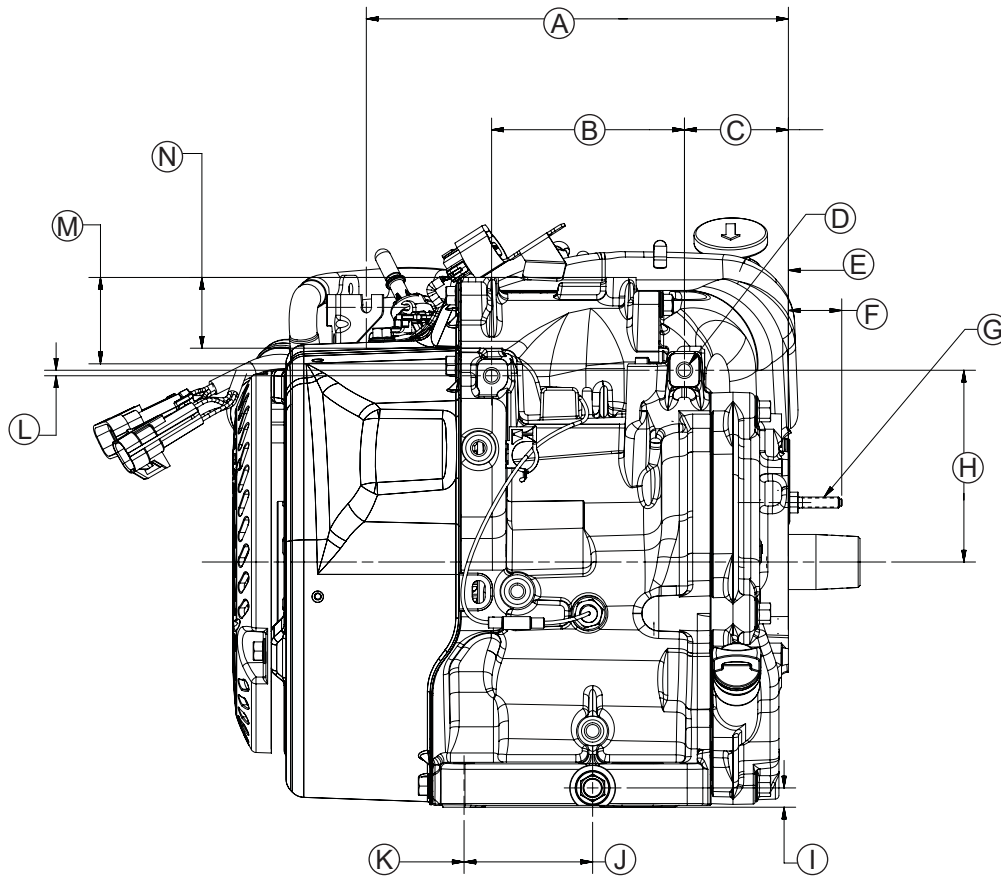

<b>A</b>	229.8 mm (9.05 in.) Throttle Cable Mount Face	<b>B</b>	105.0 mm (4.13 in.)	<b>C</b>	56.6 mm (2.23 in.)	<b>D</b>	2 X M8 X 1.25-6H Tap 22.0 mm (0.87 in.) Deep
<b>E</b>	Primary Mounting Face	<b>F</b>	29.1 mm (1.14 in.)	<b>G</b>	M6 X 1.0-6H 14.5 mm Min. Full Thread (Ground Location)	<b>H</b>	104.4 mm (4.11 in.)
<b>I</b>	2 X 10.5 mm (0.41 in.)	<b>J</b>	2 X 70.0 mm (2.76 in.)	<b>K</b>	Engine Mounting Hole Center Line	<b>L</b>	3.0 mm (0.12 in.)
<b>M</b>	47.0 mm (1.85 in.)	<b>N</b>	38.5 mm (1.52 in.)				

Engine Dimensions-Bottom Side

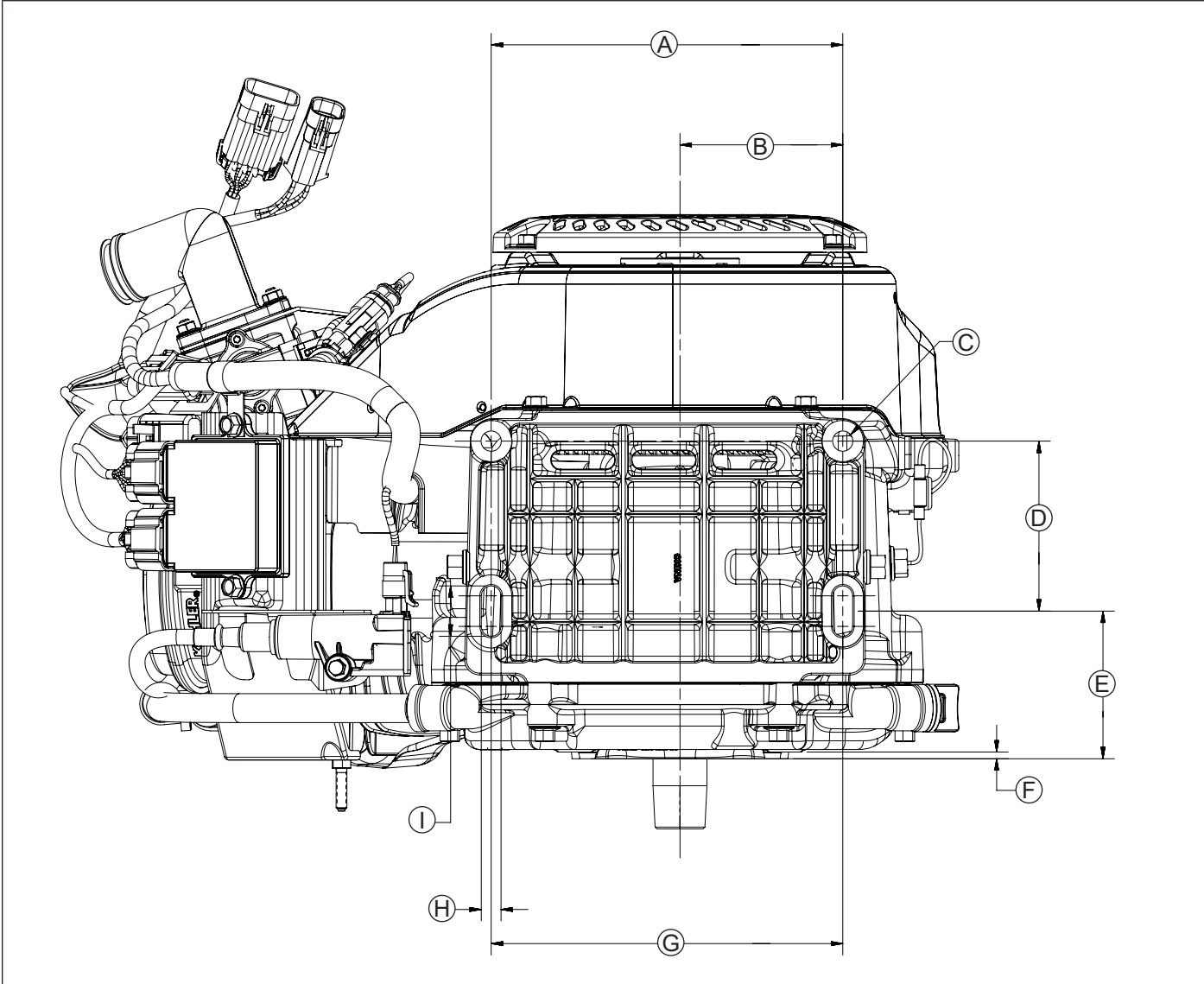

<b>A</b>	195.5 mm ± 0.50 mm (7.70 in. ± 0.02 in.) Machined Holes Distance	<b>B</b>	90.5 mm (3.56 in.)	<b>C</b>	2 X Ø 11.25 mm ± 0.25 mm (0.44 in. ± 0.01 in.)	<b>D</b>	2 X 94.5 mm ± 0.75 mm (3.72 in. ± 0.03 in.)
<b>E</b>	82.1 mm (3.23 in.)	<b>F</b>	3.75 mm (0.15 in.) Pilot	<b>G</b>	195.5 mm ± 1.0 mm (7.70 in. ± 0.04 in.) Cast Holes Distance	<b>H</b>	2 X 11.0 mm ± 0.25 mm (0.43 in. ± 0.01 in.) As Cast
<b>I</b>	2 X 28.0 mm ± 0.25 mm (1.10 in. ± 0.01 in.) As Cast						

# Specifications

## ENGINE IDENTIFICATION NUMBERS

Kohler engine identification numbers (model, specification and serial) should be referenced for efficient repair, ordering correct parts, and engine replacement.

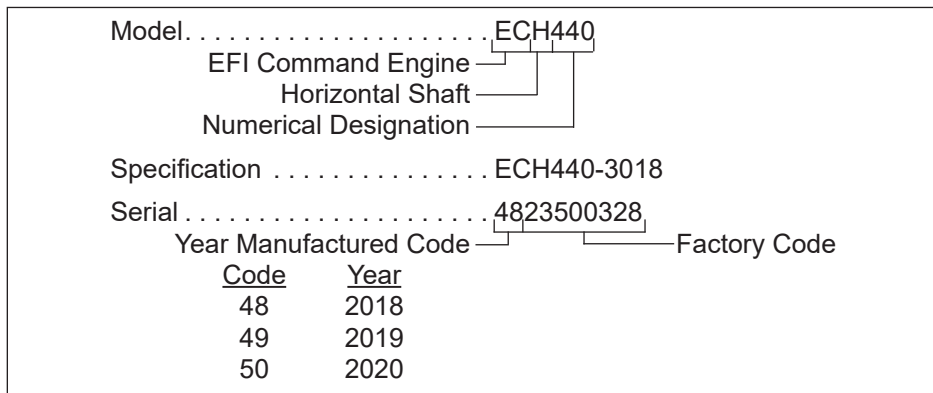

## GENERAL SPECIFICATIONS<sup>4,5</sup>

	ECH440 for Club Car
Bore	89 mm (3.5 in.)
Stroke	69 mm (2.7 in.)
Displacement	429 cc (26.2 cu. in.)
Oil Capacity (refill)	1.1 L (1.16 U.S. qt.)
Maximum Angle of Operation (@ full oil level) <sup>6</sup>	25°

## TORQUE SEQUENCES

(Refer to Torque Specifications for torque values).

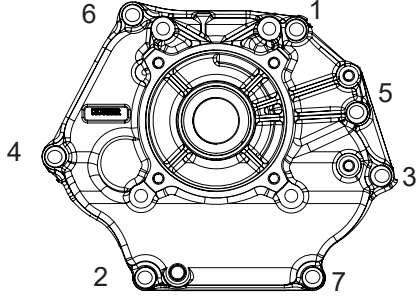
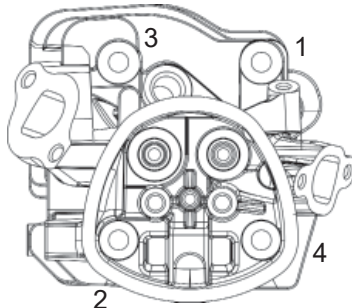
	ECH440 for Club Car
Closure Plate	
Cylinder Head	

<sup>4</sup> Values are in Metric units. Values in parentheses are English equivalents.

<sup>5</sup> Any and all horsepower (hp) references by Kohler are Certified Power Ratings and per SAE J1940 & J1995 hp standards. Details on Certified Power Ratings can be found at KohlerEngines.com.

<sup>6</sup> Exceeding maximum angle of operation may cause engine damage from insufficient lubrication.

## TORQUE SPECIFICATIONS<sup>4,7</sup>

## ECH440 for Club Car

### Air Cleaner (OEM Supplied)

Air Inlet Elbow Mounting Nuts	8.0 N·m (71 in. lb.)
-------------------------------	----------------------

### Blower Housing and Sheet Metal

M6 Screw	10 N·m (89 in. lb.)
Cylinder Shield to Cylinder Head Ground Stud and Screw	8.0 N·m (71 in. lb.)
Upper Heat Shield to Crankcase	6.2 N·m (55 in. lb.) into new holes 4.0 N·m (35 in. lb.) into used holes
Blower Housing Screen Fastener	7.3 N·m (65 in. lb.)

### Connecting Rod

Cap Fastener (torque in increments)	20 N·m (177 in. lb.)
-------------------------------------	----------------------

### Crankcase

Engine Temperature Sensor Fastener	11.9 N·m (105 in. lb.)
Oil Fill Tube Bracket Screw	5.4 N·m (48 in. lb.)
Oil Drain Plug	18 N·m (13 ft. lb.)
Oil Sentry™ Level Switch Screw	8 N·m (71 in. lb.)
Oil Sentry™ Wire Lead Nut	10 N·m (89 in. lb.)

### Closure Plate Screw (torque sequence on page 10)

Fastener	24 N·m (212 in. lb.)
----------	----------------------

### Cylinder Head (torque sequence on page 10)

Fastener (torque in 2 increments)	First to 25 N·m (221 in. lb.) Finally to 57.5 N·m (509 in. lb.)
Rocker Arm Stud	13.6 N·m (120 in. lb.)
Rocker Arm Pivot Jam Nut	10 N·m (89 in. lb.)

### Flywheel

Retaining Nut	113 N·m (1000 in. lb.)
---------------	------------------------

### Ignition

Electronic Control Unit (ECU) to Cylinder Shield Fastener	8.0 N·m (71 in. lb.)
Spark Plug	27 N·m (20 ft. lb.)
Ignition Coil Fastener	10.2 N·m (90 in. lb.)
Crankshaft Position Sensor to Bracket Screw	4.2 N·m (37 in. lb.)
Crankshaft Position Sensor Bracket to Crankcase Screw	7.3 N·m (65 in. lb.)
Ground Wire Fastener	7.3 N·m (65 in. lb.)

### Muffler (OEM Supplied)

Oxygen Sensor 14 mm (9/16 in.) wrench size	18 N·m (159 in. lb.)
--	----------------------

<sup>4</sup> Values are in Metric units. Values in parentheses are English equivalents.

<sup>7</sup> Lubricate threads with engine oil prior to assembly.

# Specifications

## TORQUE SPECIFICATIONS<sup>4,7</sup>

### ECH440 for Club Car

Throttle Body	
Studs	10 N·m (89 in. lb.)
Primary Mounting Nuts	8.0 N·m (71 in. lb.)
Temperature/Manifold Absolute Pressure (TMAP) Sensor Fastener	7.3 N·m (65 in. lb.)
Throttle Position Sensor (TPS) Fastener	1.3 N·m (11.5 in. lb.)
Throttle Lever Fastener	1.3 N·m (11.5 in. lb.)
Fuel Injector Cap Fastener	7.3 N·m (65 in. lb.)
Valve Cover	
Fastener	10 N·m (89 in. lb.)

## CLEARANCE SPECIFICATIONS<sup>4</sup>

### ECH440 for Club Car

Camshaft	
Running Clearance	0.016/0.052 mm (0.0006/0.0020 in.)
Bore I.D.	
New	16.000/16.018 mm (0.6299/0.6306 in.)
Max. Wear Limit	16.068 mm (0.6326 in.)
Camshaft Bearing Surface O.D.	
New	15.975 mm (0.6289 in.)
Max. Wear Limit	15.90 mm (0.626 in.)
Cam Lobe Profile (minimum dimension, measured from base circle to top of lobe)	
Intake - New	32.286 mm (1.271 in.)
Max. Wear Limit	32.032 mm (1.261 in.)
Exhaust - New	32.506 mm (1.280 in.)
Max. Wear Limit	32.252 mm (1.270 in.)

## Connecting Rod

Crankpin End I.D. @ 21°C (70°F)	
New	37.020/37.030 mm (1.4575/1.4579 in.)
Max. Wear Limit	37.08 mm (1.460 in.)
Connecting Rod-to-Crankpin Side Clearance	
New	0.56 mm (0.022 in.)
Max. Wear Limit	1.06 mm (0.042 in.)
Connecting Rod-to-Piston Pin Running Clearance	0.008/0.025 mm (0.0003/0.0010 in.)
Piston Pin End I.D. @ 21°C (70°F)	
New	20.006/20.017 mm (0.7876/0.7881 in.)
Max. Wear Limit	20.03 mm (0.789 in.)

<sup>4</sup> Values are in Metric units. Values in parentheses are English equivalents.

<sup>7</sup> Lubricate threads with engine oil prior to assembly.

## CLEARANCE SPECIFICATIONS<sup>4</sup>

## ECH440 for Club Car

### Crankshaft

End Play (free)	0.0508/0.254 mm (0.002/0.010 in.)
Ball Bearing Internal Clearance	0.006/0.020 mm (0.0002/0.0008 in.)
Crankshaft O.D. (new)	34.975/34.989 mm (1.3770/1.3775 in.) 35.009/35.027 mm (1.3783/1.3790 in.)
PTO end	
Flywheel end	
Connecting Rod Journal O.D.	36.975/36.985 mm (1.4557/1.4561 in.)
New	
Max. Wear Limit	36.92 mm (1.4535 in.)
Max. Taper	2.5 microns (0.0001 in.)
Max. Out-of-Round	12.7 microns (0.0005 in.)
Width	28.30/28.36 mm (1.1142/1.1165 in.)
Runout (either end)	0.025 mm (0.001 in.)
Main Bearing I.D. (Crankcase/Closure Plate)	34.988/35.000 mm (1.3775/1.3779 in.)
New (installed)	

### Cylinder Bore

Bore I.D.	89.000/89.015 mm (3.5039/3.5045 in.)
New	
Max. Wear Limit	89.185 mm (3.5112 in.)
Max. Out-of-Round	12.7 microns (0.0005 in.)
Max. Taper	12.7 microns (0.0005 in.)

### Cylinder Head

Max. Out-of-Flatness	0.1 mm (0.0039 in.)
----------------------	---------------------

### Ignition

Spark Plug Gap	1.11 mm (0.044 in.)
----------------	---------------------

<sup>4</sup> Values are in Metric units. Values in parentheses are English equivalents.



# Specifications

## CLEARANCE SPECIFICATIONS<sup>4</sup>

## ECH440 for Club Car

### Piston, Piston Rings, and Piston Pin

Piston-to-Piston Pin Running Clearance	0.002/0.016 mm (0.0001/0.0006 in.)
Piston Pin Bore I.D. New	20.000/20.008 mm (0.7874/0.7877 in.)
Max. Wear Limit	20.05 mm (0.7894 in.)
Piston Pin O.D. New	19.992/19.998 mm (0.7871/0.7873 in.)
Max. Wear Limit	19.95 mm (0.7854 in.)
Top and Center Compression Ring Side Clearance New Bore	0.045 mm (0.0018 in.)
Used Bore (Max.)	0.10 mm (0.004 in.)
Top Compression Ring End Gap New Bore	0.250/0.400 mm (0.010/0.016 in.)
Used Bore (Max.)	1.00 mm (0.039 in.)
Center Compression Ring End Gap New Bore	0.640/0.800 mm (0.025/0.032 in.)
Used Bore (Max.)	1.50 mm (0.059 in.)
Oil Control Ring-to-Groove Side Clearance	0.09/0.15 mm (0.0035/0.0059 in.)
Piston Thrust Face O.D. New	88.955/88.975 mm (3.502/3.503 in.) <sup>8</sup>
Max. Wear Limit	88.82 mm (3.497 in.)
Piston Thrust Face-to-Cylinder Bore Running Clearance	0.025/0.060 mm (0.001/0.002 in.) <sup>8</sup>



### Valves and Valve Lifters

Valve Lash	0.0762/0.127 mm (0.003/0.005 in.)
Intake Valve Stem-to-Valve Guide Running Clearance	0.025/0.055 mm (0.0010/0.0022 in.)
Exhaust Valve Stem-to-Valve Guide Running Clearance	0.040/0.07 mm (0.0016/0.0028 in.)
Intake Valve Stem O.D. New	6.57 mm (0.259 in.)
Max. Wear Limit	6.40 mm (0.252 in.)
Exhaust Valve Stem O.D. New	6.55 mm (0.258 in.)
Max. Wear Limit	6.41 mm (0.252 in.)
Intake Valve Stem to Guide New	0.025/0.055 mm (0.0010/0.0022 in.)
Max. Wear Limit	0.14 mm (0.0055 in.)
Exhaust Valve Stem to Guide New	0.040/0.070 mm (0.0016/0.0028 in.)
Max. Wear Limit	0.11 mm (0.0043 in.)
Valve Guide Reamer Size Standard Intake	6.608 mm (0.2602 in.)
Standard Exhaust	6.608 mm (0.2602 in.)
Valve Seat Width	1.20 mm (0.0472 in.)
Nominal Valve Face Angle	45°





<sup>4</sup> Values are in Metric units. Values in parentheses are English equivalents.

<sup>8</sup> Measure 29.8-30.2 mm (1.1732-1.1890 in.) above bottom of piston skirt at right angles to piston pin.

## GENERAL TORQUE VALUES

English Fastener Torque Recommendations for Standard Applications				
Bolts, Screws, Nuts and Fasteners Assembled Into Cast Iron or Steel				Grade 2 or 5 Fasteners Into Aluminum
Size	 Grade 2	 Grade 5	 Grade 8	
<b>Tightening Torque: N·m (in. lb.) ± 20%</b>				
8-32	2.3 (20)	2.8 (25)	—	2.3 (20)
10-24	3.6 (32)	4.5 (40)	—	3.6 (32)
10-32	3.6 (32)	4.5 (40)	—	—
1/4-20	7.9 (70)	13.0 (115)	18.7 (165)	7.9 (70)
1/4-28	9.6 (85)	15.8 (140)	22.6 (200)	—
5/16-18	17.0 (150)	28.3 (250)	39.6 (350)	17.0 (150)
5/16-24	18.7 (165)	30.5 (270)	—	—
3/8-16	29.4 (260)	—	—	—
3/8-24	33.9 (300)	—	—	—

Tightening Torque: N·m (ft. lb.) ± 20%				
5/16-24	—	—	40.7 (30)	—
3/8-16	—	47.5 (35)	67.8 (50)	—
3/8-24	—	54.2 (40)	81.4 (60)	—
7/16-14	47.5 (35)	74.6 (55)	108.5 (80)	—
7/16-20	61.0 (45)	101.7 (75)	142.5 (105)	—
1/2-13	67.8 (50)	108.5 (80)	155.9 (115)	—
1/2-20	94.9 (70)	142.4 (105)	223.7 (165)	—
9/16-12	101.7 (75)	169.5 (125)	237.3 (175)	—
9/16-18	135.6 (100)	223.7 (165)	311.9 (230)	—
5/8-11	149.5 (110)	244.1 (180)	352.6 (260)	—
5/8-18	189.8 (140)	311.9 (230)	447.5 (330)	—
3/4-10	199.3 (147)	332.2 (245)	474.6 (350)	—
3/4-16	271.2 (200)	440.7 (325)	637.3 (470)	—

Metric Fastener Torque Recommendations for Standard Applications						
Size	Property Class					Noncritical Fasteners Into Aluminum
	 4.8	 5.8	 8.8	 10.9	 12.9	
<b>Tightening Torque: N·m (in. lb.) ± 10%</b>						
M4	1.2 (11)	1.7 (15)	2.9 (26)	4.1 (36)	5.0 (44)	2.0 (18)
M5	2.5 (22)	3.2 (28)	5.8 (51)	8.1 (72)	9.7 (86)	4.0 (35)
M6	4.3 (38)	5.7 (50)	9.9 (88)	14.0 (124)	16.5 (146)	6.8 (60)
M8	10.5 (93)	13.6 (120)	24.4 (216)	33.9 (300)	40.7 (360)	17.0 (150)
<b>Tightening Torque: N·m (ft. lb.) ± 10%</b>						
M10	21.7 (16)	27.1 (20)	47.5 (35)	66.4 (49)	81.4 (60)	33.9 (25)
M12	36.6 (27)	47.5 (35)	82.7 (61)	116.6 (86)	139.7 (103)	61.0 (45)
M14	58.3 (43)	76.4 (56)	131.5 (97)	184.4 (136)	219.7 (162)	94.9 (70)

Torque Conversions	
N·m = in. lb. x 0.113	in. lb. = N·m x 8.85
N·m = ft. lb. x 1.356	ft. lb. = N·m x 0.737

## Tools and Aids

Certain quality tools are designed to help you perform specific disassembly, repair, and reassembly procedures. By using these tools, you can properly service engines easier, faster, and safer! In addition, you'll increase your service capabilities and customer satisfaction by decreasing engine downtime.

Here is a list of tools and their source.

NOTE: Not all tools listed are required to service this engine.

### SEPARATE TOOL SUPPLIERS

Kohler Tools  
Contact your local Kohler source of supply.

SE Tools  
415 Howard St.  
Lapeer, MI 48446  
Phone 810-664-2981  
Toll Free 800-664-2981  
Fax 810-664-8181

Design Technology Inc.  
768 Burr Oak Drive  
Westmont, IL 60559  
Phone 630-920-1300  
Fax 630-920-0011

### TOOLS

Description	Source/Part No.
<b>Alcohol Content Tester</b> For testing alcohol content (%) in reformulated/oxygenated fuels.	Kohler 25 455 11-S
<b>Camshaft Endplay Plate</b> For checking camshaft endplay.	SE Tools KLR-82405
<b>Camshaft Seal Protector (Aegis)</b> For protecting seal during camshaft installation.	SE Tools KLR-82417
<b>Cylinder Leakdown Tester</b> For checking combustion retention and if cylinder, piston, rings, or valves are worn. Individual component available: Adapter 12 mm x 14 mm (Required for leakdown test on XT-6 engines)	Kohler 25 761 05-S Design Technology Inc. DTI-731-03
<b>Dealer Tool Kit (Domestic)</b> Complete kit of Kohler required tools. Components of 25 761 39-S Ignition System Tester Cylinder Leakdown Tester Oil Pressure Test Kit Rectifier-Regulator Tester (120 V AC/60Hz)	Kohler 25 761 39-S  Kohler 25 455 01-S Kohler 25 761 05-S Kohler 25 761 06-S Kohler 25 761 20-S
<b>Dealer Tool Kit (International)</b> Complete kit of Kohler required tools. Components of 25 761 42-S Ignition System Tester Cylinder Leakdown Tester Oil Pressure Test Kit Rectifier-Regulator Tester (240 V AC/50Hz)	Kohler 25 761 42-S  Kohler 25 455 01-S Kohler 25 761 05-S Kohler 25 761 06-S Kohler 25 761 41-S
<b>Digital Vacuum/Pressure Tester</b> For checking crankcase vacuum. Individual component available: Rubber Adapter Plug	Design Technology Inc. DTI-721-01 Design Technology Inc. DTI-721-10
<b>Electronic Fuel Injection (EFI) Diagnostic Software</b> For Laptop or Desktop PC.	Kohler 25 761 23-S
<b>EFI Service Kit</b> For troubleshooting and setting up an EFI engine. Components of 24 761 01-S Fuel Pressure Tester Noid Light 90° Adapter Code Plug, Red Wire Code Plug, Blue Wire Shrader Valve Adapter Hose Wire Probe Set (2 pieces regular wire with clip; 1 piece fused wire) Hose Removal Tool, Dual Size/End (also sold as individual Kohler tool) K-Line Adapter Jumper Lead Wiring Harness	Kohler 24 761 01-S  Design Technology Inc. DTI-019 DTI-021 DTI-023 DTI-027 DTI-029 DTI-037 DTI-031 DTI-033 Kohler 25 176 23-S
<b>Kohler Wireless Diagnostic System Module (Bluetooth®)</b> For wireless Android EFI diagnostics. Individual component available: Wireless Diagnostic System Interface Cable	Kohler 25 761 45-S  Kohler 25 761 44-S

**TOOLS**

Description	Source/Part No.
<b>Flywheel Puller</b> For properly removing flywheel from engine.	SE Tools KLR-82408
<b>Hose Removal Tool, Dual Size/End (also available in EFI Service Kit)</b> Used to properly remove fuel hose from engine components.	Kohler 25 455 20-S
<b>Hydraulic Valve Lifter Tool</b> For removing and installing hydraulic lifters.	Kohler 25 761 38-S
<b>Ignition System Tester</b> For testing output on all systems, including CD.	Kohler 25 455 01-S
<b>Inductive Tachometer (Digital)</b> For checking operating speed (RPM) of an engine.	Design Technology Inc. DTI-110
<b>Offset Wrench (K and M Series)</b> For removing and reinstalling cylinder barrel retaining nuts.	Kohler 52 455 04-S
<b>Oil Pressure Test Kit</b> For testing/verifying oil pressure on pressure lubricated engines.	Kohler 25 761 06-S
<b>Rectifier-Regulator Tester (120 volt current)</b> <b>Rectifier-Regulator Tester (240 volt current)</b> For testing rectifier-regulators. Components of 25 761 20-S and 25 761 41-S CS-PRO Regulator Test Harness Special Regulator Test Harness with Diode	Kohler 25 761 20-S Kohler 25 761 41-S  Design Technology Inc. DTI-031R DTI-033R
<b>Spark Advance Module (SAM) Tester</b> For testing SAM (ASAM and DSAM) on engines with SMART-SPARK™.	Kohler 25 761 40-S
<b>Starter Servicing Kit (All Starters)</b> For removing and reinstalling drive retaining rings and brushes. Individual component available: Starter Brush Holding Tool (Solenoid Shift)	SE Tools KLR-82411  SE Tools KLR-82416
<b>Stepper Motor Controller Tool</b> For testing operation of stepper motor/Digital Linear Actuator (DLA).	Kohler 25 455 21-S
<b>Jumper Lead Tool</b> For use with Stepper Motor Controller Tool to test rotary stepper motor.	Kohler 25 518 43-S
<b>Triad/OHC Timing Tool Set</b> For holding cam gears and crankshaft in timed position while installing timing belt.	Kohler 28 761 01-S
<b>Valve Guide Reamer (K and M Series)</b> For properly sizing valve guides after installation.	Design Technology Inc. DTI-K828
<b>Valve Guide Reamer O.S. (Command Series)</b> For reaming worn valve guides to accept replacement oversize valves. Can be used in low-speed drill press or with handle below for hand reaming.	Kohler 25 455 12-S
<b>Reamer Handle</b> For hand reaming using Kohler 25 455 12-S reamer.	Design Technology Inc. DTI-K830

**AIDS**

Description	Source/Part No.
<b>Camshaft Lubricant (Valspar ZZ613)</b>	Kohler 25 357 14-S
<b>Dielectric Grease (GE/Novaguard G661)</b>	Kohler 25 357 11-S
<b>Dielectric Grease</b>	Loctite® 51360
<b>Kohler Electric Starter Drive Lubricant (Inertia Drive)</b>	Kohler 52 357 01-S
<b>Kohler Electric Starter Drive Lubricant (Solenoid Shift)</b>	Kohler 52 357 02-S
<b>RTV Silicone Sealant</b> Loctite® 5900® Heavy Body in 4 oz. aerosol dispenser. Only oxime-based, oil resistant RTV sealants, such as those listed, are approved for use. Permatex® the Right Stuff® 1 Minute Gasket™ or Loctite® Nos. 5900® or 5910® are recommended for best sealing characteristics.	Kohler 25 597 07-S Loctite® 5910® Loctite® Ultra Black 598™ Loctite® Ultra Blue 587™ Loctite® Ultra Copper 5920™ Permatex® the Right Stuff® 1 Minute Gasket™
<b>Spline Drive Lubricant</b>	Kohler 25 357 12-S

## Tools and Aids

### FLYWHEEL HOLDING TOOL

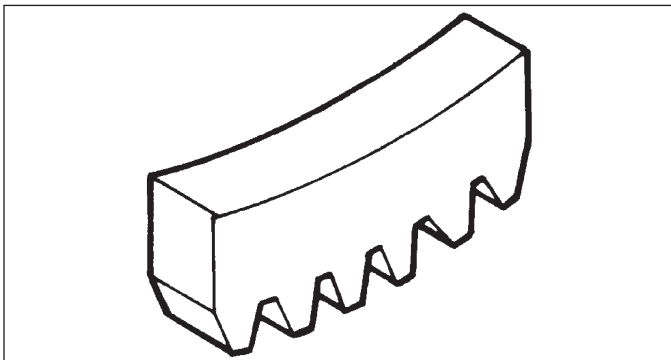

A flywheel holding tool can be made out of an old junk flywheel ring gear and used in place of a strap wrench.

1. Using an abrasive cut-off wheel, cut out a six tooth segment of ring gear as shown.
2. Grind off any burrs or sharp edges.
3. Invert segment and place it between ignition bosses on crankcase so tool teeth engage flywheel ring gear teeth. Bosses will lock tool and flywheel in position for loosening, tightening, or removing with a puller.

### ROCKER ARM/CRANKSHAFT TOOL

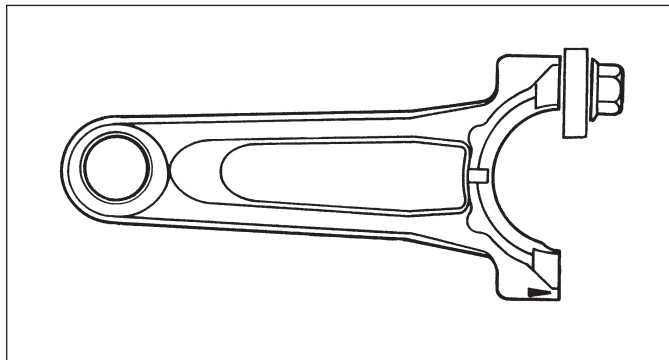

A spanner wrench to lift rocker arms or turn crankshaft may be made out of an old junk connecting rod.

1. Find a used connecting rod from a 10 HP or larger engine. Remove and discard rod cap.
2. Remove studs of a Posi-Lock rod or grind off aligning steps of a Command rod, so joint surface is flat.
3. Find a 1 in. long capscrew with correct thread size to match threads in connecting rod.
4. Use a flat washer with correct I.D. to slip on capscrew and approximately 1 in. O.D. Assemble capscrew and washer to joint surface of rod.

## TROUBLESHOOTING GUIDE

When troubles occur, be sure to check simple causes which, at first, may seem too obvious to be considered. For example, a starting problem could be caused by an empty fuel tank.

NOTE: An EFI engine will not operate without a battery connected to system.

Some general common causes of EFI engine troubles are listed below and vary by engine specification. Use these to locate causing factors.

### Engine Cranks But Will Not Start

---

- Battery connected backwards.
- Blown fuses.
- Clogged fuel line or fuel filter.
- Empty fuel tank.
- Faulty ignition coil.
- Faulty spark plug.
- Fuel pump malfunction.
- Insufficient voltage to electronic control unit.
- Interlock circuit is engaged or faulty.
- Key switch or kill switch in OFF position.
- Quality of fuel (dirt, water, stale, mixture).
- Spark plug lead disconnected.

### Engine Starts But Does Not Keep Running

---

- Faulty cylinder head gasket.
- Faulty or misadjusted throttle controls.
- Fuel pump malfunction.
- Intake leak.
- Loose wires or connections that intermittently ground ignition kill circuit.
- Quality of fuel (dirt, water, stale, mixture).
- Restricted fuel tank cap vent.

### Engine Starts Hard

---

- Clogged fuel line or fuel filter.
- Engine overheated.
- Faulty ACR mechanism.
- Faulty spark plug.
- Flywheel key sheared.
- Fuel pump malfunction.
- Interlock circuit is engaged or faulty.
- Loose wires or connections that intermittently ground ignition kill circuit.
- Low compression.
- Quality of fuel (dirt, water, stale, mixture).
- Weak spark.

### Engine Will Not Crank

---

- Battery is discharged.
- Faulty starter circuit.
- Faulty key switch or ignition switch.
- Interlock circuit is engaged or faulty.
- Loose wires or connections that intermittently ground ignition kill circuit.
- Seized internal engine components.

### Engine Runs But Misses

---

- Fuel system issue (Fuel Injector).
- Engine overheated.
- Faulty spark plug.
- Ignition coil faulty.
- Interlock circuit is engaged or faulty.
- Loose wires or connections that intermittently ground ignition kill circuit.
- Quality of fuel (dirt, water, stale, mixture).
- Spark plug lead disconnected.
- Spark plug lead boot loose on plug.
- Spark plug lead loose.

### Engine Will Not Idle

---

- Engine overheated.
- Faulty spark plug.
- Idle speed adjusting screw improperly set.
- Inadequate fuel supply.
- Low compression.
- Quality of fuel (dirt, water, stale, mixture).
- Restricted fuel tank cap vent.

### Engine Overheats

---

- Cooling fan broken.
- Excessive engine load.
- Lean fuel mixture.
- Low crankcase oil level.
- Cooling system components clogged or restricted.

### Engine Knocks

---

- Excessive engine load.
- Incorrect valve lash adjustment.
- Incorrect oil viscosity/type.
- Internal wear or damage.
- Low crankcase oil level.
- Quality of fuel (dirt, water, stale, mixture).
- Loose/worn pulley/clutch on crankshaft PTO.

# Troubleshooting

## Engine Loses Power

- Dirty air cleaner element (OEM supplied).
- Engine overheated.
- Excessive engine load.
- Restricted exhaust (OEM supplied).
- Faulty spark plug.
- High crankcase oil level.
- Incorrect governor setting (OEM supplied).
- Low battery.
- Low compression.
- Low crankcase oil level.
- Quality of fuel (dirt, water, stale, mixture).

## Engine Uses Excessive Amount of Oil

- Loose or improperly torqued fasteners.
- Blown head gasket/overheated.
- Breather reed broken.
- Clogged, broken, or inoperative crankcase breather.
- Crankcase overfilled.
- Incorrect oil viscosity/type.
- Worn cylinder bore.
- Worn or broken piston rings.
- Worn valve stems/valve guides.

## Oil Leaks from Oil Seals, Gaskets

- Breather reed broken.
- Clogged, broken, or inoperative crankcase breather.
- Loose or improperly torqued fasteners.
- Piston blow by, or leaky valves.
- Restricted exhaust (OEM supplied).

## EXTERNAL ENGINE INSPECTION

**NOTE:** It is good practice to drain oil at a location away from workbench. Be sure to allow ample time for complete drainage.

Before cleaning or disassembling engine, make a thorough inspection of its external appearance and condition. This inspection can give clues to what might be found inside engines (and cause) when it is disassembled.

- Check for buildup of dirt and debris on crankcase, cooling fins, screen, and other external surfaces. Dirt or debris on these areas can cause overheating.
- Check for obvious fuel and oil leaks, and damaged components. Excessive oil leakage can indicate a clogged or inoperative breather, worn or damaged seals or gaskets, or loose fasteners.
- Check air cleaner system (OEM supplied) for damage or indications of improper fit and seal.

- Check air cleaner element (OEM supplied). Look for holes, tears, cracked or damaged sealing surfaces, or other damage that could allow unfiltered air into engine. A dirty or clogged element could indicate insufficient or improper maintenance.
- Check throttle body throat for dirt. Dirt in throat is further indication that air cleaner was not functioning properly.
- Check if oil level is within operating range on dipstick. If it is above, sniff for gasoline odor.
- Check condition of oil. Drain oil into a container; it should flow freely. Check for metal chips and other foreign particles.

Sludge is a natural by-product of combustion; a small accumulation is normal. Excessive sludge formation could indicate over rich fuel settings, weak ignition, overextended oil change interval or wrong weight or type of oil was used.

## CLEANING ENGINE

	<b>⚠ WARNING</b>
	Cleaning Solvents can cause severe injury or death. Use only in well ventilated areas away from ignition sources.
Carburetor cleaners and solvents are extremely flammable. Follow cleaner manufacturer's warnings and instructions on its proper and safe use. Never use gasoline as a cleaning agent.	

After inspecting external condition of engine, clean engine thoroughly before disassembly. Clean individual components as engine is disassembled. Only clean parts can be accurately inspected and gauged for wear or damage. There are many commercially available cleaners that will quickly remove grease, oil, and grime from engine parts. When such a cleaner is used, follow manufacturer's instructions and safety precautions carefully.

Make sure all traces of cleaner are removed before engine is reassembled and placed into operation. Even small amounts of these cleaners can quickly break down lubricating properties of engine oil.

## CRANKCASE VACUUM TEST

	<b>⚠ WARNING</b>
	Carbon Monoxide can cause severe nausea, fainting or death. Avoid inhaling exhaust fumes.
Engine exhaust gases contain poisonous carbon monoxide. Carbon monoxide is odorless, colorless, and can cause death if inhaled.	

	<b>⚠ WARNING</b>
	Rotating Parts can cause severe injury. Stay away while engine is in operation.
Keep hands, feet, hair, and clothing away from all moving parts to prevent injury. Never operate engine with covers, shrouds, or guards removed.	

A partial vacuum should be present in crankcase when engine is operating. Pressure in crankcase (normally caused by a clogged or improperly assembled breather) can cause oil to be forced out at oil seals, gaskets, or other available spots.

Crankcase vacuum is best measured with either a water manometer or a vacuum gauge. Complete instructions are provided in kits.

To test crankcase vacuum with manometer:

1. Insert rubber stopper into oil fill hole. Be sure pinch clamp is installed on hose and use tapered adapters to connect hose between stopper and one manometer tube. Leave other tube open to atmosphere. Check that water level in manometer is at 0 line. Make sure pinch clamp is closed.
2. Start engine and run no-load high speed.
3. Open clamp and note water level in tube.  
Level in engine side should be a minimum of 10.2 cm (4 in.) above level in open side.  
If level in engine side is less than specified (low/no vacuum), or level in engine side is lower than level in open side (pressure), check for conditions in table below.
4. Close pinch clamp before stopping engine.

To test crankcase vacuum with vacuum/pressure gauge:

1. Remove dipstick or oil fill plug/cap.
2. Install adapter into oil fill//dipstick tube opening, upside down over end of a small diameter dipstick tube, or directly into engine if a tube is not used. Insert barbed gauge fitting into hole in stopper.
3. Run engine and observe gauge reading.  
Analog tester—needle movement to left of 0 is a vacuum, and movement to right indicates a pressure.  
Digital tester—depress test button on top of tester.  
Crankcase vacuum should be a minimum of 10.2 cm (4 in.) of water. If reading is below specification, or if pressure is present, check table below for possible causes and conclusions.

Condition	Conclusion
Crankcase breather clogged or inoperative.	NOTE: If breather is integral part of valve cover and cannot be serviced separately, replace valve cover and recheck pressure. Disassemble breather, clean parts thoroughly, check sealing surfaces for flatness, reassemble, and recheck pressure.
Seals and/or gaskets leaking. Loose or improperly torque fasteners.	Replace all worn or damaged seals and gaskets. Make sure all fasteners are tightened securely. Use appropriate torque valves and sequences when necessary.
Piston blow by or leaky valves (confirm by inspecting components).	Recondition piston, rings, cylinder bore, valves and valves guides.
Restricted exhaust (OEM supplied).	Refer to equipment manufacturer's manual for information on exhaust system.



# Troubleshooting

## COMPRESSION TEST

This engine is equipped with an automatic compression release (ACR) mechanism. It is difficult to obtain an accurate compression reading because of ACR mechanism. As an alternative, use cylinder leakdown test described below.

## CYLINDER LEAKDOWN TEST

A cylinder leakdown test can be a valuable alternative to a compression test. By pressurizing combustion chamber from an external air source you can determine if valves or rings are leaking, and how badly.

Cylinder leakdown tester is a relatively simple, inexpensive leakdown tester for small engines. This tester includes a quick-connect for attaching adapter hose and a holding tool.

1. Run engine for 3-5 minutes to warm it up.
2. Remove spark plug and air filter from engine.
3. Rotate crankshaft until piston (of cylinder being tested) is at top dead center (TDC) of compression stroke. Hold engine in this position while testing. Holding tool supplied with tester can be used if PTO end of crankshaft is accessible. Lock holding tool onto crankshaft. Install a 3/8 in. breaker bar into hole/slot of holding tool, so it is perpendicular to both holding tool and crankshaft PTO.  
If flywheel end is more accessible, use a breaker bar and socket on flywheel nut/screw to hold it in position. An assistant may be needed to hold breaker bar during testing. If engine is mounted in a piece of equipment, it may be possible to hold it by clamping or wedging a driven component. Just be certain that engine cannot rotate off of TDC in either direction.
4. Install adapter into spark plug hole, but do not attach it to tester at this time.
5. Turn regulator knob completely counterclockwise.
6. Connect an air source of at least 50 psi to tester.
7. Turn regulator knob clockwise (increase direction) until gauge needle is in yellow set area at low end of scale.
8. Connect tester quick-connect to adapter hose. While firmly holding engine at TDC, gradually open tester valve. Note gauge reading and listen for escaping air at combustion air intake, exhaust outlet, and crankcase breather.

Condition	Conclusion
Air escaping from crankcase breather.	Ring or cylinder worn.
Air escaping from exhaust system.	Defective exhaust valve/improper seating.
Air escaping from intake.	Defective intake valve/improper seating.
Gauge reading in low (green) zone.	Piston rings and cylinder in good condition.
Gauge reading in moderate (yellow) zone.	Engine is still usable, but there is some wear present. Customer should start planning for overhaul or replacement.
Gauge reading in high (red) zone.	Rings and/or cylinder have considerable wear. Engine should be reconditioned or replaced.

## AIR CLEANER (OEM Supplied)

These systems are CARB/EPA certified and components should not be altered or modified in any way.

Refer to operating instructions of equipment this engine powers for specific air cleaner instructions.

### Air Inlet Elbow Components

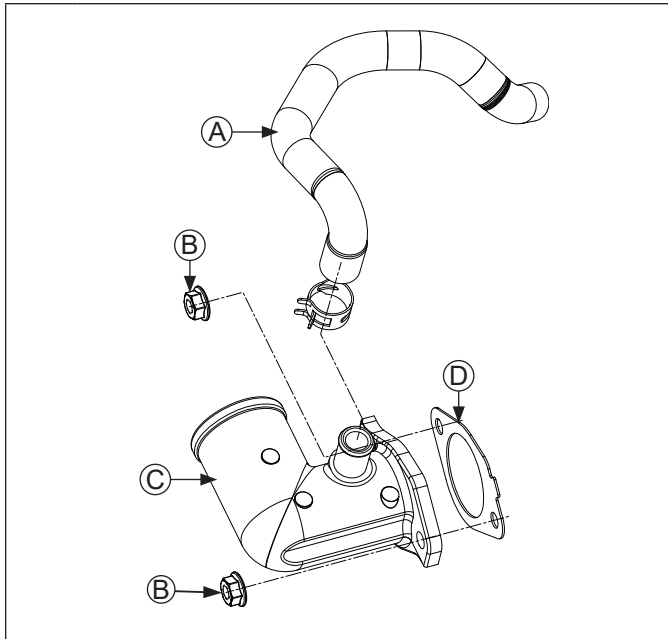

<b>A</b>	Breather Hose	<b>B</b>	Nut
<b>C</b>	Air Inlet Elbow	<b>D</b>	Throttle Body Gasket

**NOTE:** Operating engine with loose or damaged air cleaner components could cause premature wear and failure. Replace all bent or damaged components.

### Air Inlet Elbow

**NOTE:** Refer to equipment manufacturer's manual for air cleaner they supply.

1. Disconnect one end of breather hose from valve cover or air inlet elbow.
2. Remove nuts securing air inlet elbow to throttle body.
3. Remove air inlet elbow and gasket from mounting studs.

## BREATHER TUBE

Ensure both ends of breather tube are properly connected.

## AIR COOLING

	<b>WARNING</b>
	<p>Hot Parts can cause severe burns. Do not touch engine while operating or just after stopping.</p>
<p>Never operate engine with heat shields or guards removed.</p>	

Proper cooling is essential. To prevent over heating, clean screens, cooling fins, and other external surfaces of engine. Avoid spraying water at wiring harness or any electrical components. Refer to Maintenance Schedule.

# EFI SYSTEM

	<b>⚠ WARNING</b>
	Explosive Fuel can cause fires and severe burns. Do not fill fuel tank while engine is hot or running.
Gasoline is extremely flammable and its vapors can explode if ignited. Store gasoline only in approved containers, in well ventilated, unoccupied buildings, away from sparks or flames. Spilled fuel could ignite if it comes in contact with hot parts or sparks from ignition. Never use gasoline as a cleaning agent.	

**NOTE:** Engines in this application have in-tank fuel pump, EFI fuel filter, and all fuel lines supplied and installed by OEM. Refer to equipment manufacturer's manual for information on these components and before working on fuel system.

Typical electronic fuel injection (EFI) system and related components include:

- In-tank fuel pump (OEM supplied and installed).
- Fuel filter (OEM supplied and installed).
- High pressure fuel line (OEM supplied and installed).
- Fuel injector.
- Throttle body.
- Electronic control unit (ECU).
- Ignition coil.
- Engine temperature sensor.
- Throttle position sensor (TPS).
- Crankshaft position sensor.
- Oxygen sensor.
- Temperature/Manifold Absolute Pressure (TMAP) sensor.
- Wire harness assembly & affiliated wiring.
- 10 Amp fuse (ignition switch).
- 10 Amp fuse (battery power).
- Malfunction indicator light (MIL) - OEM supplied and installed).

## FUEL RECOMMENDATIONS

Refer to Maintenance.

## FUEL LINE (OEM Supplied)

Low permeation fuel line must be installed on all Kohler Co. engines to maintain EPA and CARB regulatory compliance.

## OPERATION

**NOTE:** When performing voltage or continuity tests, avoid putting excessive pressure on or against connector pins. Pin probes (maximum diameter 0.81 mm (0.032 in.) approximately) are recommended for testing to avoid spreading or bending terminals.

EFI system is designed to provide peak engine performance with optimum fuel efficiency and lowest possible emissions. Ignition and injection functions are electronically controlled, monitored and continually corrected during operation to maintain ideal air/fuel ratio.

Central component of system is Electronic Control Unit (ECU) which manages system operation, determining best combination of fuel mixture and ignition timing for current operating conditions.

An in-tank fuel pump is used to move fuel from tank through a fuel filter and fuel line. Fuel pump regulates fuel pressure to a system operating pressure of 50 psi. Fuel is delivered through high pressure fuel line into injector, which injects fuel into intake port. ECU controls amount of fuel by varying length of time that injector is on. This can range from 2 to over 12 milliseconds depending on fuel requirements. Controlled injection of fuel occurs every other crankshaft revolution, or once for each 4-stroke cycle. When intake valve opens, air/fuel mixture is drawn into combustion chamber, where it is compressed, ignited, and burned.

ECU controls amount of fuel being injected and ignition timing by monitoring primary sensor signals for engine temperature, speed (RPM), and throttle position (load). These primary signals are compared to preprogrammed maps in ECU computer chip, and ECU adjusts fuel delivery to match mapped values. After engine reaches operating temperature, an exhaust gas oxygen sensor provides feedback to ECU based upon amount of unused oxygen in exhaust, indicating whether fuel mixture being delivered is rich or lean. Based upon this feedback, ECU further adjusts fuel input to re-establish ideal air/fuel ratio. This operating mode is referred to as closed loop operation. EFI system operates closed loop when all three of following conditions are met:

- Engine temperature is greater than 40°C (104°F).
- Oxygen sensor has warmed sufficiently to provide a signal (minimum 400°C, 752°F).
- Engine operation is at a steady state (not starting, warming up, accelerating, etc.).

During closed loop operation ECU has ability to readjust temporary and learned adaptive controls, providing compensation for changes in overall engine condition and operating environment, so it will be able to maintain ideal air/fuel ratio. This system requires a minimum engine temperature of 40°C (104°F) to properly adapt. These adaptive values are maintained as long as ECU is not reset.

During certain operating periods such as cold starts, warm up, acceleration, high load, etc., a richer air/fuel ratio is required and system operates in an open loop mode. In open loop operation oxygen sensor output is used to ensure engine is running rich, and controlling adjustments are based on primary sensor signals and programmed maps only. This system operates open loop whenever three conditions for closed loop operation (above) are not being met.

ECU is brain or central processing computer of entire EFI system. During operation, sensors continuously gather data which is relayed through wiring harness to input circuits within ECU. Signals to ECU include: ignition (on/off), crankshaft position and speed (RPM), throttle position, engine temperature, intake air temperature, exhaust oxygen levels, manifold absolute pressure, and battery voltage.

ECU compares input signals to programmed maps in its memory to determine appropriate fuel and spark requirements for immediate operating conditions. ECU then sends output signals to set injector duration and ignition timing.

ECU continually performs a diagnostic check of itself, each sensor, and system performance. If a fault is detected, ECU can turn on a Malfunction Indicator Light (MIL) on equipment control panel, store fault code in its fault memory, and go into a default operating mode. Depending on significance or severity of fault, normal operation may continue. A technician can access stored fault code using a fault code diagnosis flashed out through MIL. An optional computer software diagnostic program is also available, refer to Tools and Aids.

ECU requires a minimum of 6.0 volts to operate.

To prevent engine over-speed and possible failure, a rev-limiting feature is programmed into ECU. If maximum RPM limit (4400) is exceeded, ECU suppresses injection signals, cutting off fuel flow. This process repeats itself in rapid succession, limiting operation to preset maximum.

Wiring harness used in EFI system connects electrical components, providing current and ground paths for system to operate. All input and output signaling occurs through two special all weather connectors that attach and lock to ECU. Connectors are Black and Grey and keyed differently to prevent being attached to ECU incorrectly.

Condition of wiring, connectors, and terminal connections is essential to system function and performance. Corrosion, moisture, and poor connections are as likely a cause of operating problems and system errors as an actual component. Refer to Electrical System for additional information.

EFI system is a 12 VDC negative ground system, designed to operate down to a minimum of 6.0 volts. If system voltage drops below this level, operation of voltage sensitive components such as ECU, fuel pump relay, ignition coil, and injector will be intermittent or disrupted, causing erratic operation or hard starting. A fully charged, 12 volt battery with a minimum of 350 cold cranking amps is important in maintaining steady and reliable system operation. Battery condition and state of charge should always be checked first when troubleshooting an operational problem.

Keep in mind that EFI-related problems are often caused by wiring harness or connections. Even small amounts of corrosion or oxidation on terminals can interfere with milliamp currents used in system operation.

Cleaning connectors and grounds will solve problems in many cases. In an emergency situation, simply disconnecting and reconnecting connectors may clean up contacts enough to restore operation, at least temporarily.

If a fault code indicates a problem with an electrical component, disconnect ECU connector and test for continuity between component connector terminals and corresponding terminals in ECU connector using an ohmmeter. Little or no resistance should be measured, indicating that wiring of that particular circuit is OK.

Crankshaft position sensor is essential to engine operation; constantly monitoring rotation and speed (RPM) of crankshaft. There are 23 consecutive teeth cast into flywheel. One tooth is missing and is used to reference crankshaft position for ECU.

When ignition is turned ON, ECU captures and records battery voltage. During engine start (cranking) voltage drops 2+ volts. When ECU receives voltage drop input, it then looks for a signal from crankshaft position sensor. During rotation, an AC voltage pulse is created within sensor for each passing tooth. ECU calculates engine speed from time interval between consecutive pulses. Gap from missing tooth creates an interrupted input signal, corresponding to specific crankshaft position near BDC for cylinder. This signal serves as a reference for control of ignition timing by ECU. Synchronization of inductive speed pickup and crankshaft position takes place during first two revolutions each time engine is started. Sensor must be properly connected at all times. If sensor becomes disconnected for any reason, engine will quit running.

Throttle position sensor (TPS) is used to indicate throttle plate angle to ECU. Since throttle (by way of governor) reacts to engine load, angle of throttle plate is directly related to load on engine.

Mounted on throttle body and operated directly off end of throttle shaft, TPS works by varying voltage signal to ECU in direct correlation to angle of throttle plate. This signal, along with other sensor signals, is processed by ECU and compared to internal preprogrammed maps to determine required fuel and ignition settings for amount of load.

Correct position of TPS is established and set at factory. Do not loosen TPS or alter mounting position unless absolutely required by fault code diagnosis. If TPS is loosened or repositioned, appropriate TPS Learn Procedure must be performed to re-establish baseline relationship between ECU and TPS.

Engine temperature sensor is used by system to help determine fuel requirements for starting (a cold engine needs more fuel than one at or near operating temperature).

Mounted on cylinder head, it has a temperature-sensitive resistor. Resistance changes with engine temperature, altering voltage sent to ECU. Using a table stored in its memory, ECU correlates voltage drop to a specific temperature. Using fuel delivery maps, ECU then knows how much fuel is required for starting at that temperature.

Temperature/Manifold Absolute Pressure (TMAP) sensor is an integrated sensor that checks both intake air temperature and manifold absolute pressure.

Intake Air Temperature control is a thermally sensitive resistor that exhibits a change in electrical resistance with a change in its temperature. When sensor is cold, resistance of sensor is high. As sensor warms up, resistance drops and voltage signal increases. From voltage signal, ECU can determine temperature of intake air.

## EFI SYSTEM

Purpose of sensing air temperature is to help ECU calculate air density. Higher air temperature less dense air becomes. As air becomes less dense ECU knows that it needs to lessen fuel flow to achieve correct air/fuel ratio. If fuel flow was not changed engine would become rich, possibly losing power and consuming more fuel.

Manifold Absolute Pressure check provides immediate manifold pressure information to ECU. TMAP sensor measures difference in pressure between outside atmosphere and vacuum level inside intake passage and monitors pressure in passage as primary means of detecting load. Data is used to calculate air density and determine engine's mass air flow rate, which in turn determines required ideal fueling. TMAP also stores instant barometric pressure reading when key is turned ON.

Oxygen sensor functions like a small battery, generating a voltage signal to ECU based upon difference in oxygen content between exhaust gas and an air reference signal.

Tip of sensor, protruding into exhaust gas, is hollow. Outer portion of tip is surrounded by exhaust gas, using a pumping current to maintain nominal air reference of approximately 21% oxygen in air reference chamber of sensor, differences between exhaust and air reference are sent using a generated voltage signal of up to 1.0 volt to ECU. Voltage signal tells ECU if engine is straying from ideal fuel mixture, and ECU then adjusts injector pulse accordingly.

Oxygen sensor functions after being heated to a minimum of 400°C (752°F). A heater inside sensor heats electrode to optimum temperature in about 10 seconds. Oxygen sensor receives ground through wire, eliminating need for proper grounding through muffler. If problems indicate a bad oxygen sensor, check all connections and wire harness. Oxygen sensor can also be contaminated by leaded fuel, certain RTV and/or other silicone compounds, fuel injector cleaners, etc. Use only those products indicated as O2 Sensor Safe.

Fuel injector mounts on throttle body and high pressure fuel line attaches to cap on fuel injector. Replaceable O-rings on both ends of injector prevent external fuel leakage and also insulate it from heat and vibration. A special clip connects injector and fuel injector cap. O-rings and retaining clip must be replaced any time fuel injector is separated from its normal mounting position.

When key switch is on, fuel pump will pressurize high pressure fuel line to 50 psi, and voltage is present at injector. At proper instant, ECU completes ground circuit, energizing injector. Valve needle in injector is opened electromagnetically, and pressure in high pressure fuel line forces fuel down through injector. Director plate at tip of injector contains a series of calibrated openings which directs fuel into intake passage in a cone-shaped spray pattern.

Injector has sequential fueling that opens and closes once every other crankshaft revolution. Amount of fuel injected is controlled by ECU and determined by length of time valve needle is held open, also referred to as injection duration or pulse width. Time injector is open (milliseconds) may vary in duration depending on speed and load requirements of engine.

A high-voltage, solid-state, battery ignition system is used with EFI system. ECU controls ignition output and timing through transistorized control of primary current delivered to coil. Based on input from crankshaft position sensor, ECU determines correct firing point for speed at which engine is running. At proper instant, it interrupts flow of primary current in coil, causing electromagnetic flux field to collapse. Flux collapse induces an instantaneous high voltage in coil secondary which is strong enough to bridge gap on spark plug. Coil fires every other revolution.

Equipment this engine powers has a starter generator, refer to equipment manufacturer's manual for charging system troubleshooting information.

An electric in-tank fuel pump (OEM supplied) is used to transfer fuel in EFI system. Fuel pump is regulated at 350 kilopascals (50 psi).

When key switch is turned ON and all safety switch requirements are met, ECU activates fuel pump for up to six seconds (prime process), which pressurizes system for start-up. If key switch is not promptly turned to start position, engine fails to start, or engine is stopped with key switch ON (as in case of an accident), ECU switches off pump preventing continued delivery of fuel. Once engine is running, fuel pump remains on.

A special EFI 10-micron filter (OEM supplied) is in fuel tank. Be sure to use an approved 10-micron filter for replacement. Refer to equipment manufacturer's manual for information.

High pressure fuel line assembly (OEM supplied) attaches to injector cap and fuel pump using connectors. High pressure fuel line feeds fuel to top of injector through injector cap.

Vent hose assembly (OEM supplied) is intended to vent fuel vapor out of fuel tank, through an OEM supplied carbon canister and then directs all fuel vapor into purge port located on throttle body.

EFI engines have no carburetor, so throttle function (regulate incoming combustion airflow) is achieved with a throttle valve in a separate throttle body attached to cylinder head/intake port/air inlet elbow. Throttle body provides mounting for fuel injector, throttle position sensor, TMAP sensor, high pressure fuel line, idle speed screw, and air inlet elbow.

Idle speed is only adjustment that may be performed on throttle body. Standard idle speed setting is 1050 RPM for pedal start applications or 1250 RPM for key start applications.

For starting and warm up, ECU will adjust fuel and ignition timing, based upon ambient temperature, engine temperature, and loads present. In cold conditions, idle speed will probably be different than normal for a few moments. Under other conditions, idle speed may actually start lower than normal, but gradually increase to established setting as operation continues. Do not attempt to circumvent this warm up period, or readjust idle speed during this time. Engine must be completely warmed up, in closed loop operating mode for accurate idle adjustment.

## IMPORTANT NOTES!

- Cleanliness is essential and must be maintained at all times when servicing or working on EFI system. Dirt, even in small quantities, can cause significant problems.
- Clean any joint or fitting with parts cleaning solvent before opening to prevent dirt from entering system.
- Always depressurize fuel system through fuel connector on fuel pump before disconnecting or servicing any fuel system components. Refer to equipment manufacturer's manual for information.
- Never attempt to service any fuel system component while engine is running or ignition switch is ON.
- Do not use compressed air if system is open. Cover any parts removed and wrap any open joints with plastic if they will remain open for any length of time. New parts should be removed from their protective packaging just prior to installation.
- Avoid direct water or spray contact with system components.
- Do not disconnect or reconnect ECU wiring harness connector or any individual components with ignition on. This can send a damaging voltage spike through ECU.
- Do not allow battery cables to touch opposing terminals. When connecting battery cables attach positive (+) cable to positive (+) battery terminal first, followed by negative (-) cable to negative (-) battery terminal.
- Never start engine when cables are loose or poorly connected to battery terminals.
- Never disconnect battery while engine is running.
- Never use a quick battery charger to start engine.
- Do not charge battery with key switch ON.
- Always disconnect negative (-) battery cable before charging battery, and also unplug harness from ECU before performing any welding on equipment.

# EFI SYSTEM

## ELECTRICAL COMPONENTS

### Electronic Control Unit (ECU)

#### Pinout of ECU

Black Connector Side	
Pin #	Function
1	Ignition Coil Ground
2	Battery Ground
3	Diagnostic Communication Line
4	Speed Sensor input
5	Fuel Injector Output Ground
6	Not Used
7	Oxygen Sensor Heater
8	Intake Air Temperature (TMAP) sensor input
9	Fuel Pump Ground
10	Ground for TPS, TMAP, O2 and Oil Sensors
11	Manifold Absolute Pressure (TMAP) sensor input
12	Throttle Position Sensor (TPS) input
13	Speed Sensor Ground
14	Engine Temperature Sensor input
15	Ignition Switch (Switched +12V)
16	Power for TPS and TMAP Sensors (+5V)
17	Oxygen Sensor (O2) input
18	Battery Power (Permanent +12V)

Grey Connector Side	
Pin #	Description
1	Not Used
2	Not Used
3	Malfunction Indicator Light (MIL) Ground
4	Not Used
5	Not Used
6	Not Used
7	Not Used
8	Not Used
9	Battery Ground
10	Not Used
11	Not Used
12	Not Used
13	Not Used
14	Safety Switch Ground
15	Not Used
16	ECU
17	Fuel Pump Control (+12V)
18	Not Used

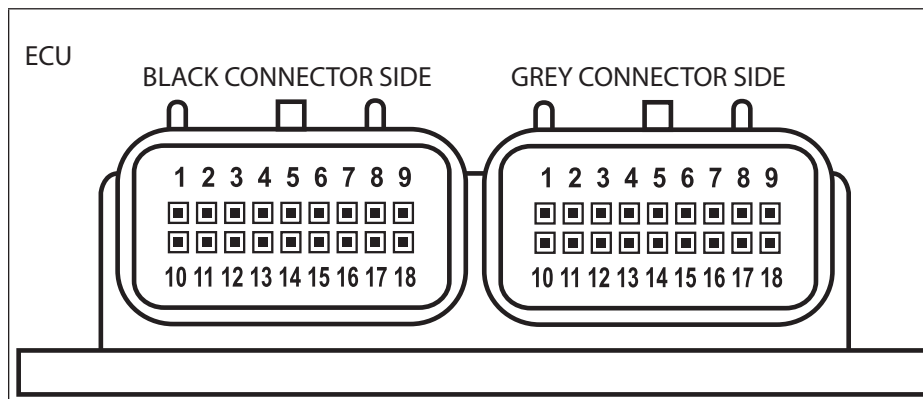

**Pinout of ECU**

Never attempt to disassemble ECU. It is sealed to prevent damage to internal components. Warranty is void if case is opened or tampered with in any way.

All operating and control functions within ECU are preset. No internal servicing or readjustment may be performed. If a problem is encountered, and you determine ECU to be faulty, contact your source of supply.

ECU pins are coated at factory with a thin layer of electrical grease to prevent fretting and corrosion. Do not attempt to remove grease from ECU pins.

Relationship between ECU and throttle position sensor (TPS) is very critical to proper system operation. If TPS or ECU is changed, or mounting position of TPS is altered, appropriate TPS Learn Procedure must be performed to restore synchronization.

Any service to ECU, TPS/Throttle Body (including idle speed increase over 300 RPM), or fuel pump replacement should include ECU Reset.

This will clear all trouble codes, all closed loop learned offsets, all max values, and all timers besides permanent hour meter.

This system will NOT reset when battery is disconnected!

### ECU Reset Procedure

1. Turn key/ignition OFF.
2. Install Red wire jumper from Kohler EFI service kit on to service port (connect white wire to black wire in 4 way diagnostic port).
3. Turn key/ignition ON, then OFF and count 15 seconds.
4. Turn key/ignition ON, then OFF and count to 15 seconds a second time.
5. Remove Red wire jumper. Turn key/ignition ON, then OFF and count to 15 seconds a third time. ECU is reset.

A TPS Learn Procedure **must** be performed after ECU Reset. Follow TPS Learn Procedure for appropriate specific application being serviced.

### TPS Learn Procedure for Pedal Start Applications

NOTE: Refer to equipment manufacturer's manual for details on throttle body cover and throttle cable removal/reinstallation.

1. Remove throttle body cover.
2. Disconnect throttle cable from throttle lever.
3. Turn idle screw clockwise one full turn prior to key/ignition ON after ECU Reset.
4. Start engine, run at low idle until engine is warm.
5. Idle speed must be above 1100 RPM. If below 1100 RPM, turn idle screw up to 1200 RPM and then shut down engine and perform ECU Reset again.
6. Restart engine, adjust idle speed down to 1050 RPM. Allow engine to dwell at 1050 RPM for about 3 seconds.
7. Turn key/ignition OFF and count to 15 seconds.
8. Reinstall throttle cable.
9. Reinstall throttle body cover.

Learn procedure for pedal start application is complete.

### TPS Learn Procedure for Key Start Applications

1. Turn idle screw clockwise one full turn prior to key/ignition ON after ECU Reset.
2. Start engine, run at low idle until engine is warm.
3. Idle speed must be above 1200 RPM. If below 1200 RPM, turn idle screw up to 1300 RPM and then shut down engine and perform ECU Reset again.
4. Restart engine, adjust idle speed down to 1250 RPM. Allow engine to dwell at 1250 RPM for about 3 seconds.
5. Turn key/ignition OFF and count to 15 seconds.

Learn procedure for key start application is complete.



# EFI SYSTEM

Wiring Diagram

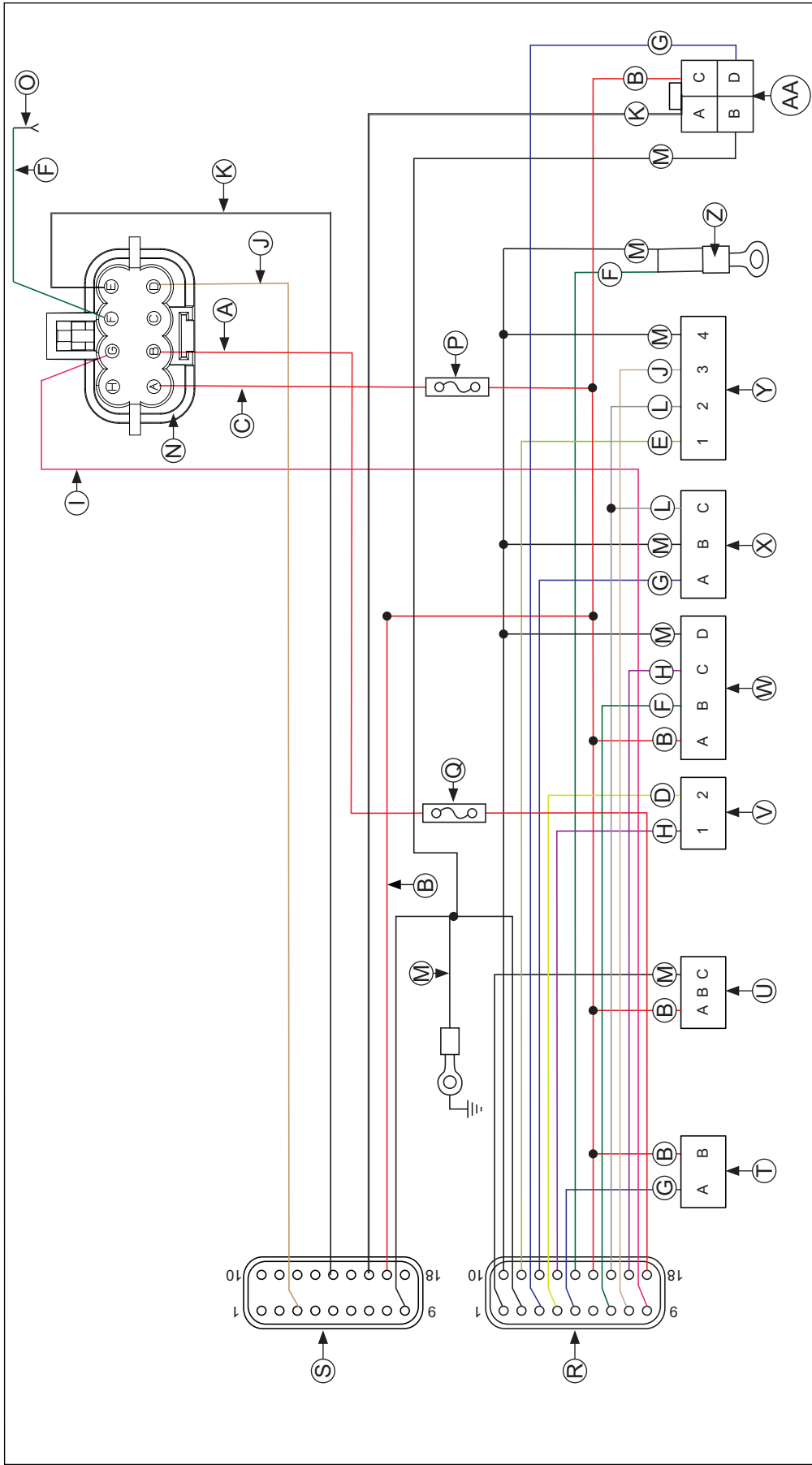

<b>A</b>	Red	Red/Black	<b>C</b>	Red/White	<b>D</b>	Yellow	<b>E</b>	Light Green
<b>F</b>	Dark Green	Dark Blue	<b>H</b>	Purple	<b>I</b>	Pink (OEM Fuel Pump Relay)	<b>J</b>	Tan
<b>K</b>	White	Grey	<b>M</b>	Black	<b>N</b>	8-Terminal Customer Connector	<b>O</b>	Oil Level Switch
<b>P</b>	10A Fuse (Ignition Switch)	10A Fuse (Battery Power)	<b>R</b>	Black Connector	<b>S</b>	Grey Connector	<b>T</b>	Fuel Injector
<b>U</b>	Ignition Coil	Crankshaft Position Sensor	<b>W</b>	Oxygen Sensor	<b>X</b>	Throttle Position Sensor	<b>Y</b>	TMAP Sensor
<b>Z</b>	Engine Temperature Sensor	Diagnostic Connector						

**Crankshaft Position Sensor**

A sealed, non-serviceable assembly. If fault code P0337 is present and engine does not start/run, proceed to step 1. If P0337 is present and engine operates, clear codes and retest. If Fault Code diagnosis indicates a problem within this area, test and correct as follows.

1. Inspect wiring and connections for damage or problems.
2. Make sure engine has resistor type spark plug.
3. Disconnect Black connector from ECU.
4. Connect an ohmmeter between #4 and #13 pin terminals. A resistance value of 325-395 Ω at room temperature (20°C, 68°F) should be obtained. If resistance is correct, remove blower housing to check sensor mounting, flywheel teeth (damage, run-out, etc.), and flywheel key. Follow procedures in Disassembly to remove blower housing.
5. Disconnect crankshaft position sensor connector from wiring harness. Test resistance between terminals. A reading of 325-395 Ω should again be obtained.
  - a. If resistance is incorrect, remove screw securing sensor to bracket and replace sensor.
  - b. If resistance in step 4 was incorrect, but resistance of sensor alone was correct, test wire harness circuits between sensor connector terminals and corresponding pin terminals (#4 and #13) in main connector. Correct any observed problem, reconnect sensor, and perform step 4 again.
6. When fault is corrected and engine starts, clear fault codes following ECU Reset procedure.

**Throttle Position Sensor (TPS)**

TPS is a sealed, non-serviceable assembly. If diagnosis indicates a bad sensor, complete replacement is necessary. If a fault code indicates a problem with TPS, it can be tested as follows:

Diagnostics of sensor: ECU will have electrical faults captured in fault codes P0122 and P0123. Fault code P0122 detecting low voltage, open circuit, and P0123 for high voltage conditions between ECU, wire harness, and sensor. Tip: when working with any electrical connection, remember to keep connections clean & dry. This is best accomplished by cleaning connection thoroughly prior to disassembly. Contaminated sensor connections can cause premature engine faults. Functionally testing sensor cannot be done with simple resistance checks. If either of these two faults is present or a TPS fault is suspected, recommended diagnostic test is as follows:

**If a computer with diagnostic software is available**

Observe throttle percent and raw TPS values through diagnostic software. With diagnostic software communicating to ECU and key ON engine not running, these values can be observed while throttle is moved from closed to full open position. There should be a smooth and repeatable throttle percent value starting at closed position reading between 0 and 3% to WOT position reading of 93 to 100%. If one of these values is outside of specified range and output transitions in a smooth manner, reset ECU and run test again.

Since there is no longer any wear elements inside sensor, most likely faults will be in electrical connections between sensor and wire harness and wire harness to ECU. With service software communicating to ECU and engine not running, a small load or gentle back and forth motion can be applied to connectors or wires just outside connectors to detect a faulty connection.

**If only a volt meter is available**

Measure voltage supply to sensor from ECU. This voltage should be 5.00 +/- 0.20 volts. This can be measured by gently probing terminals B & C on harness side with TPS connector removed from TPS and key ON. This will generate a P0122 fault that can be cleared with an ECU reset. If voltage is low, battery, harness and ECU should be investigated. If supply voltage is good, plug sensor back into harness. Probe sensor signal wire with volt meter, terminal A at TPS or pin Black 12 at ECU. This signal should start between 0.6-1.2 volts at low idle and grow smoothly as throttle is opened to 4.3-4.8 volts at full open (WOT). Since there is no longer any wear elements inside sensor, most likely faults will be in electrical connections between sensor and wire harness and wire harness to ECU.

**Replace TPS**

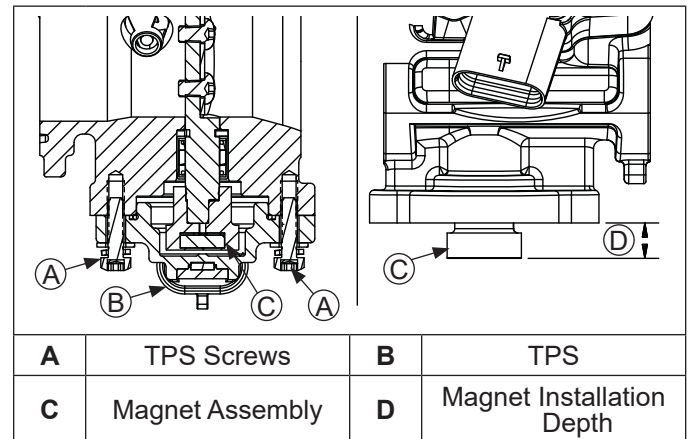

Magnet assembly is captured in a small plastic housing that is press fit to end of throttle shaft. If replacement is required, it can be replaced as follows:

1. Remove screws securing TPS to throttle body. Remove sensor from throttle body, exposing round magnet assembly.
2. A pair of flat blade screw drivers or a spanner tool can be used to pry this off shaft. Caution should be used to avoid damage to machined flat surface that sensor seals against. Also, make sure throttle blade is in full open position to avoid driving throttle blade into throttle bore causing damage to blade and/or bore.
3. When replacing magnet assembly, alignment is critical. There is a D-shaped drive feature on end of shaft and a matching pocket in magnet assembly. On outer diameter of magnet assembly is a notch that aligns with center of flat feature of D. Align this notch and flat of D feature in shaft and preassemble parts.

## EFI SYSTEM

- With throttle blade in full open position (WOT), press magnet assembly fully on to throttle shaft. Full insertion can be checked by measuring height from throttle body sensor mounting face to end of magnet assembly. This should be no more than 8.6 mm (0.34 in.). Installation process requires significant force, so take care that all parts are aligned. Tapping magnet assembly on can fracture/damage brittle magnet within assembly and throttle body assembly and is NOT RECOMMENDED.
- Install sensor and secure with screws. Torque screws to 1.3 N·m (11.5 in. lb.).

### Engine Temperature Sensor

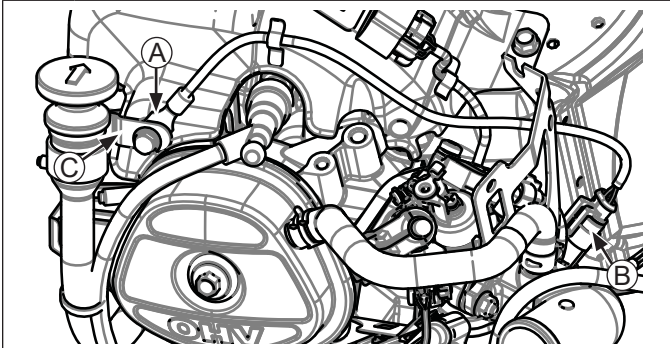

<b>A</b>	Engine Temperature Sensor
<b>B</b>	Unplug Sensor to Replace
<b>C</b>	Dipstick Tube Bracket

NOTE: Engine temperature sensor resembles a ground wire.

A sealed, serviceable assembly. A faulty sensor requires replacement. If a fault code indicates a problem with temperature sensor, it can be tested as follows:

- Shut off engine and allow it to return to room temperature (25°C, 77°F).
- With sensor still connected, check temperature sensor circuit resistance between Black pin 10 and 14 terminals. Value should be 9000-11000 Ω.
- If resistance is out of specifications, unplug sensor from wiring harness and replace. Note that sensor is installed under dipstick tube bracket.

### Temperature/Manifold Absolute Pressure (TMAP) Sensor

A sealed non-serviceable integrated sensor that checks both intake air temperature and manifold absolute pressure. Complete replacement is required if it is faulty. Sensor and wiring harness can be checked as follows.

If a fault code indicates a problem with Intake Air Temperature (TMAP) Sensor Circuit (P0112 or P0113), it can be tested as follows:

- Remove TMAP sensor from throttle body.
- Allow it to reach room temperature (20°C, 68°F).
- Unplug Black connector from ECU.
- With sensor still connected, check temperature sensor circuit resistance between Black pin 10 and 8 pin terminals. Value should be 1850-2450 Ω.
- Unplug sensor from wire harness and check sensor resistance separately across pin. Resistance value should again be 1850-2450 Ω.
  - If resistance is out of specifications, check local temperature. Sensor resistance will go down as temperature is higher. Replace TMAP sensor if determined to be faulty.
  - If it is within specifications, proceed to Step 6.
- Check circuits (input, ground), from main harness connector to sensor plug for continuity, damage, etc. Connect one ohmmeter lead to Black pin 8 in main harness connector (as in step 4). Connect other lead to terminal #3 in sensor plug. Continuity should be indicated. Repeat test between Black pin 10 and terminal #4 in sensor plug.
- Reinstall sensor.

If a fault code indicates a problem with Manifold Absolute Pressure (TMAP) Sensor Circuit (P0107 or P0108), it can be tested as follows:

- Make sure all connections are making proper contact and are free of dirt and debris. Slide locking tab out and pull off TMAP connector. Turn key switch to ON and check with a volt meter by contacting red lead to pin 1 and black lead to pin 2. There should be 5 volts present, indicating ECU and wiring harness are functioning.
- Check continuity in wire harness. Ohms between Pin 3 at sensor connector and Black pin 11 connector at ECU should be near zero ohms. If no continuity is measured or very high resistance, replace wire harness.
- Check to make sure throttle body is not loose and TMAP sensor is not loose. Loose parts would allow a vacuum leak, making TMAP sensor report misleading information to ECU.
  - Tighten all hardware and perform an ECU Reset and a TPS Learn Procedure to see if MIL will display a fault with sensor again. If MIL finds a fault with TMAP sensor, replace it.

**Oxygen Sensor (O2)**

**Detail**

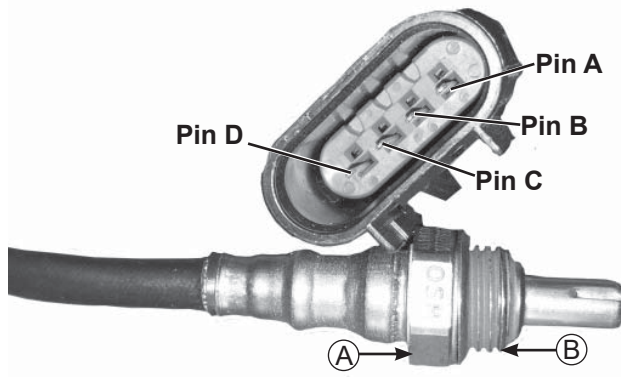

<b>Pin A</b>	Purple Wire, Heater +	<b>Pin B</b>	White Wire, Heater -
<b>Pin C</b>	Grey Wire, Sensor Output	<b>Pin D</b>	Black Wire, Sensor Ground
<b>A</b>	14 mm or 9/16 in. Wrench Size	<b>B</b>	12 mm x 1.25 Thread Size

Installation Torque 18 N·m (159 in. lb.)

**Cutaway Oxygen Sensor (O2) Components**

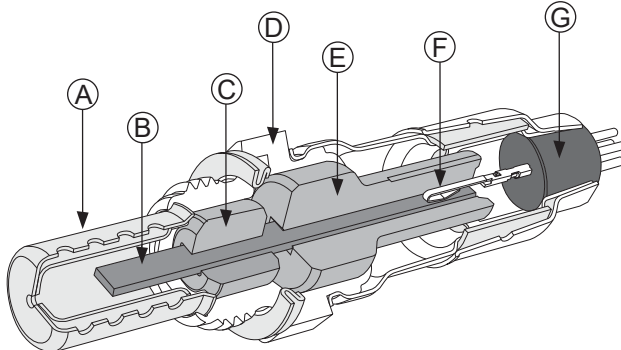

<b>A</b>	Protection Shield	<b>B</b>	Planar Element and Heater
<b>C</b>	Lower Insulator	<b>D</b>	Stainless Steel Housing
<b>E</b>	Upper Insulator	<b>F</b>	Terminal Connection to Element
<b>G</b>	High Temp Water Seal		

Temperature must be controlled very accurately and gas constituents measured to a high degree of accuracy for absolute sensor measurements. This requires laboratory equipment to determine a good or bad sensor in field. Furthermore, as with most devices, intermittent problems are difficult to diagnose. Still, with a good understanding of system and sensor, it is possible to diagnose many sensor problems in field.

Using diagnostic software connected to ECU is a useful technique for observing sensor performance. However, user must understand that such software reads a signal generated by ECU. If there is an ECU or wiring problem, readings could be misinterpreted as a sensor problem. Digital nature of signal to software means that it is not reading continuous output of sensor. A voltmeter can also be used as an effective tool in diagnosing sensors.

It is advisable to use an electronic meter such as a digital voltmeter. Simple mechanical meters may place a heavy electrical load on sensor and cause inaccurate readings. Since resistance of sensor is highest at low temperatures, such meters will cause largest inaccuracies when sensor is in a cool exhaust.

**Visual Inspection**

**Sensor Wire Detail**

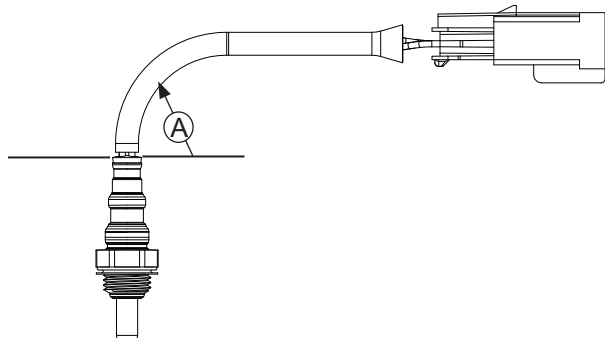

<b>A</b>	Keep a minimum of 25 mm (1.0 in.) radius at grommet.
----------	--

NOTE: Always route harness away from hot exhaust and away from moving parts.

NOTE: **Do not attempt to clean sensor.** Replace as needed.

1. Look for a damaged or disconnected sensor-to-engine harness connection.
2. Look for damage to sensor lead wire or associated engine wiring due to cutting, chaffing or melting on a hot surface.
3. Disconnect sensor connector and look for corrosion in connector.
4. Try reconnecting sensor and observe if problem has cleared.
5. Correct any problems found during visual check.
6. Inspect for any exhaust system leaks upstream or downstream of oxygen sensor. Confirm oxygen sensor is secured to 18 N·m (159 in. lb.).

All leaks must be repaired and an ECU/TPS reset must be performed before proceeding with sensor testing.

7. Using diagnostic software, document any trouble codes. Determine if historic trouble codes are logically related to current fault experienced. If uncertain, clear codes and retest.

# EFI SYSTEM

## Sensor Signal Observation

### Engine Harness O2 Sensor Connector Plug Detail

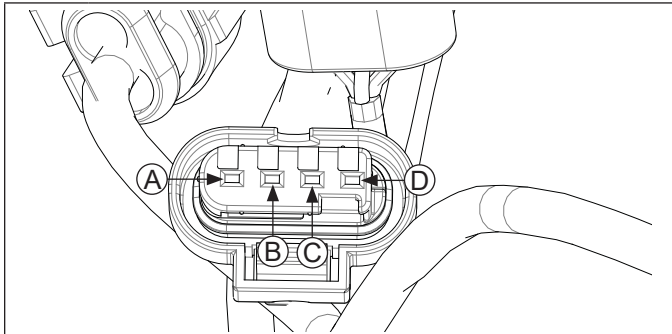

<b>A</b>	Red w/Black Stripe	<b>B</b>	Dark Green
<b>C</b>	Purple	<b>D</b>	Black

NOTE: **Do not cut into or pierce sensor or engine wiring to make this connection.** Sensor produces a very small signal. Corrosion or damage to wiring could lead to an incorrect signal because of repairs or contamination to sensor.

1. With sensor connected and using diagnostic software, start engine to observe O2 sensor activity. Run engine at sufficient speed to bring sensor and engine up to operating temperature (engine temperature of 150°F (66°C) or more displayed by diagnostic software).

Maintained throttle openings of less than 37% typically display closed loop operation where sensor output voltage should cycle between 0.05 to 0.95 Volts.

Maintained throttle openings of 38-50% and above typically display open loop operation where sensor should have above 0.500 Volt. Occasional spikes outside these values is normal. Lack of continuous fluctuation is not an indication of a defective sensor.

2. With key ON and engine OFF, sensor connected, using diagnostic software, O2 volts displayed should be more than 1.0 volt. This voltage is generated by ECU. If not present, there may be a power and/or ground supply fault to engine harness or ECU, a fault of engine harness itself (refer to Visual Inspection), or a fault of ECU.

With key ON and sensor unplugged, using a digital voltmeter, observe voltage between Pin socket C and Pin socket D of engine wiring harness (refer to engine harness connector plug detail at top of page). Voltage should read approximately 5.0 volts.

3. Using a digital voltmeter, observe system sensor voltage between Pin socket A and negative (-) battery ground. Battery voltage should be seen. If battery voltage is not seen, inspect engine wiring, fuses, and/or electrical connections.

## Removal Inspection

NOTE: Apply anti-seize compound only to threads.

**Anti-seize compound will affect sensor performance if it gets into lower shield of sensor.**

1. If sensor has heavy deposits on lower shield, engine, oil, or fuel may be source.
2. If heavy carbon deposits are observed, incorrect engine fuel control may be occurring.
3. With sensor at room temperature, measure heater circuit resistance, purple wire (Pin A) and white wire (Pin B).

Resistance should be 16.5-19.5 Ω.



4. If a damaged sensor is found, identify root cause, which may be elsewhere in application. Refer to Troubleshooting-Oxygen (O2) Sensor table.
5. A special "dry to touch" anti-seize compound is applied to all new oxygen sensors at factory. If recommended mounting thread sizes are used, this material provides excellent anti-seize capabilities and no additional anti-seize is needed. If sensor is removed from engine and reinstalled, anti-seize compound should be reapplied. Use an oxygen sensor safe type anti-seize compound. It should be applied according to directions on label. Torque sensor to 18 N·m (159 in. lb.).

Troubleshooting-Oxygen (O2) Sensor

Condition	Possible Cause	Conclusion
Continuous low voltage output (less than 400mV) observed with throttle openings of 38-50% or more.  Fault codes P0131, P0171, or P0174 may set.	Shorted sensor or sensor circuit. Shorted lead wire. Wiring shorted to ground.	Replace sensor or replace and properly route wiring.
	Upstream or downstream exhaust leaks observed. Air leak at sensor.	Repair all exhaust leaks and torque sensor to 18 N·m (159 in. lb.).
	Restricted fuel supply.	Resolve fuel supply issues from tank to engine. Test fuel pressure. Perform repairs necessary.
	Misfire	A misfire causing incomplete combustion will result in lean (low voltage) values.
	Sensor failure-stuck lean.	Replace sensor.
Continuous high voltage output (600mV or more) observed with throttle openings of 37% or less.  Fault codes P0172 or P0132 may set.	Silica poisoning.	Replace sensor. Identify and resolve root cause.
	Contaminated gasoline.	Purge fuel system and retest.
	Wiring shorted to voltage.	Replace damaged harness.
	Overly rich condition due to unmetered fuel entering combustion chamber.	Test fuel pressure. Inspect fuel pump vent and evaporative emissions hoses for raw fuel flow. Inspect engine oil for fuel contamination; drain and refill if suspect. Perform repairs as necessary.
	Cold engine. Engine temperature below 150°F (66°C) as displayed by diagnostic software.	Normal operation, or engine operated in an excessively cold environment.
	Sensor failure-stuck rich.	Replace sensor.
No activity from sensor.  Diagnostic software displays 1.015 Volts continuously.  Fault codes P0031 or P0032 may set.	Heater circuit open or shorted.	Replace sensor.
	Engine keyed ON with sensor disconnected. Historic codes.	Secure and/or confirm sensor connection and clear codes.
	Contaminated gasoline.	Purge fuel system and retest.
	Broken wire. Damaged sensor.	Replace sensor.

# EFI SYSTEM

## Fuel Injector

	 <b>WARNING</b>
	<p>Explosive Fuel can cause fires and severe burns.</p> <p>Do not fill fuel tank while engine is hot or running.</p>
<p>Gasoline is extremely flammable and its vapors can explode if ignited. Store gasoline only in approved containers, in well ventilated, unoccupied buildings, away from sparks or flames. Spilled fuel could ignite if it comes in contact with hot parts or sparks from ignition. Never use gasoline as a cleaning agent.</p>	

### Details

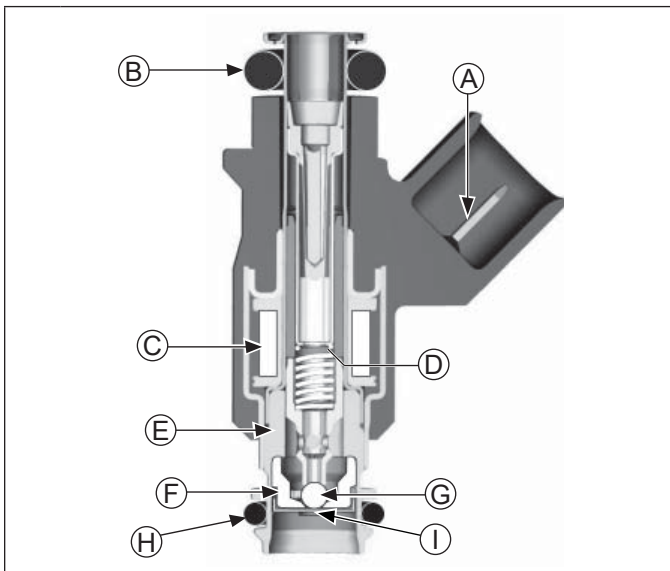

<b>A</b>	Electrical Connection	<b>B</b>	Upper O-ring
<b>C</b>	Solenoid Winding	<b>D</b>	Armature
<b>E</b>	Valve Housing	<b>F</b>	Valve Seat
<b>G</b>	Valve End	<b>H</b>	Lower O-ring
<b>I</b>	Director Plate		

**NOTE:** Do not apply voltage to fuel injector. Excessive voltage will burn out injector. Do not ground injector with ignition ON. Injector will open/turn on if relay is energized.

**NOTE:** When cranking engine with injector disconnected, fault codes will be registered in ECU and will need to be cleared using software fault clear or an ECU Reset and TPS Learn Procedure.

Injector problems typically fall into three general categories: electrical, dirty/clogged, or leakage. Injector problems due to dirt or clogging are generally unlikely due to design of injector, high fuel pressure, and detergent additives in gasoline. Symptoms that could be caused by dirty/clogged injector include rough idle, hesitation/stumbling during acceleration, or triggering of fault codes related to fuel delivery.

Injector clogging is usually caused by a buildup of deposits on director plate, restricting flow of fuel, resulting in a poor spray pattern. Some contributing factors to injector clogging include higher than normal operating temperatures, short operating intervals, and dirty, incorrect, or poor quality fuel.

Cleaning of clogged injector is not recommended; it should be replaced. Additives and higher grades of fuel can be used as a preventative measure if clogging has been a problem.

An electrical problem usually will cause injector to stop functioning. Several methods may be used to check if injector is operating.

1. With engine running at idle, listen for a buzzing or clicking sound.
2. Disconnect electrical connector from injector and engine should stop running. If engine continues to run, disconnect vent line at air cleaner base. If engine continues to run, injector is suspect.

If an injector is not operating, it can indicate either a bad injector, or a wiring/electrical connection problem. Check as follows:

1. Disconnect electrical connector from injector. Plug a 12 volt noid light into connector.
2. Make sure all safety switch requirements are met. Crank engine and check for flashing of noid light.
  - a. If flashing occurs, use an ohmmeter (Rx1 scale) and check resistance of injector across two terminals. Proper resistance is 11-13  $\Omega$ . If injector resistance is correct, check whether connector and injector terminals are making a good connection. If resistance is not correct, replace injector.

Check all electrical connections, connectors, and wiring harness leads if resistance is incorrect.

Injector leakage is very unlikely, but in those rare instances it can be internal (past tip of valve needle), or external (weeping around injector O-ring). Loss of system pressure from leakage can cause hot restart problems and longer cranking times. Refer to Disassembly for removal of injector.

1. Remove throttle body from engine leaving TPS, high pressure fuel line, injector and fuel line connections intact. Discard old gaskets.
2. Position throttle body over an appropriate container to capture fuel and turn key switch ON to activate fuel pump and pressurize system. Do not turn switch to START position.
3. If injector exhibits leakage of more than two to four drops per minute from tip, or shows any sign of leakage around outer shell, turn ignition switch OFF and replace injector as follows.
4. Depressurize fuel system and disconnect high pressure fuel line from fuel injector cap.
5. Clean any dirt accumulation from sealing/mounting area of faulty injector and disconnect electrical connector.

6. Pull retaining clip to separate fuel injector cap/ bracket assembly from injector. Remove screw holding fuel injector cap/bracket assembly to throttle body. Lift injector from throttle body.
7. Reverse appropriate procedures to install new injector and reassemble engine. Use new O-ring and retaining clip any time an injector is removed (new replacement injector includes new O-rings and retaining clip). Lubricate O-rings lightly with clean engine oil. Use installation tool provided with O-rings to install new upper O-ring. Place tool into fuel injector inlet. Place one side of O-ring into O-ring groove and roll O-ring over tool onto fuel injector. Torque screw securing fuel injector cap to 7.3 N·m (65 in. lb.). An ECU Reset and TPS Learn Procedure will need to be completed.

## Ignition Coil

If coil is determined to be faulty, replacement is necessary. An ohmmeter may be used to test wiring and coil windings.

NOTE: Do not ground coil with ignition ON as it may overheat or spark.

NOTE: Always disconnect spark plug lead from spark plug before performing following tests.

NOTE: **If ignition coil is disabled and an ignition fault is registered, system will automatically disable corresponding fuel injector drive signal.** Fault must be corrected to ignition coil and ECU power (switch) must be turned OFF for 15 seconds for injector signal to return. This is a safety measure to prevent bore washing and oil dilution.

## Testing

Using an ohmmeter set on Rx1 scale, check resistance in circuit as follows:

1. To check ignition coil, disconnect Black connector from ECU and test between Black pins 1 and 15. Wiring and coil primary circuit is OK if reading is 0.85-1.15 Ω.
2. If reading is not within specified range, check and clean connections and retest.
3. If reading is still not within specified range, test coil separately from main harness as follows:
  - a. Remove mounting screw retaining coil and disconnect primary lead connector.
  - b. Connect an ohmmeter set on Rx1 scale to primary terminal of coil. Primary resistance should be 0.5-0.8 Ω.
  - c. Connect an ohmmeter set on Rx10K scale between spark plug boot terminal and B+ primary terminal. Secondary resistance should be 6400-7800 Ω.
  - d. If either primary or secondary resistance is not within specified range, coil is faulty and needs to be replaced.

## FUEL COMPONENTS

	<b>⚠ WARNING</b>
	<p>Explosive Fuel can cause fires and severe burns.</p> <p>Do not fill fuel tank while engine is hot or running.</p>
<p>Gasoline is extremely flammable and its vapors can explode if ignited. Store gasoline only in approved containers, in well ventilated, unoccupied buildings, away from sparks or flames. Spilled fuel could ignite if it comes in contact with hot parts or sparks from ignition. Never use gasoline as a cleaning agent.</p>	

NOTE: Engines in this application have in-tank fuel pump, EFI fuel filter, and all fuel lines supplied and installed by OEM. Refer to equipment manufacturer's manual for information on these components and before working on fuel system.

### In-Tank Fuel Pump (OEM Supplied and Installed)

Refer to equipment manufacturer's manual for information. Use only original equipment replacement parts.

### High Pressure Fuel Line (OEM Supplied and Installed)

No specific servicing is required unless operating conditions indicate that it needs replacement. Thoroughly clean area around all joints and relieve any pressure before starting any disassembly. Refer to equipment manufacturer's manual for information. Use only original equipment replacement parts.

### Vent Hose Assembly (OEM Supplied and Installed)

Purge port is located on throttle body by TMAP sensor and no specific servicing is required. No specific servicing is required for vent hose assembly (OEM supplied) unless operating conditions indicate replacement is required. Use only original equipment replacement parts. Visit KohlerEngines.com for recommended Kohler replacement parts; refer to equipment manufacturer's manual for replacement part information.



# EFI SYSTEM

## Throttle Body Assembly

NOTE: ECU Reset is required if throttle body is replaced.

Throttle body is serviced as an assembly, with throttle shaft, TPS, throttle plate, TMAP sensor, fuel injector/cap/bracket assembly, return spring, and idle speed adjusting screw installed. Throttle shaft rotates on needle bearings (non-serviceable), capped with seals to prevent air leaks.

NOTE: If return spring is replaced, proper placement of each hook end is required. Take note of each hook end before removing screw securing throttle lever.

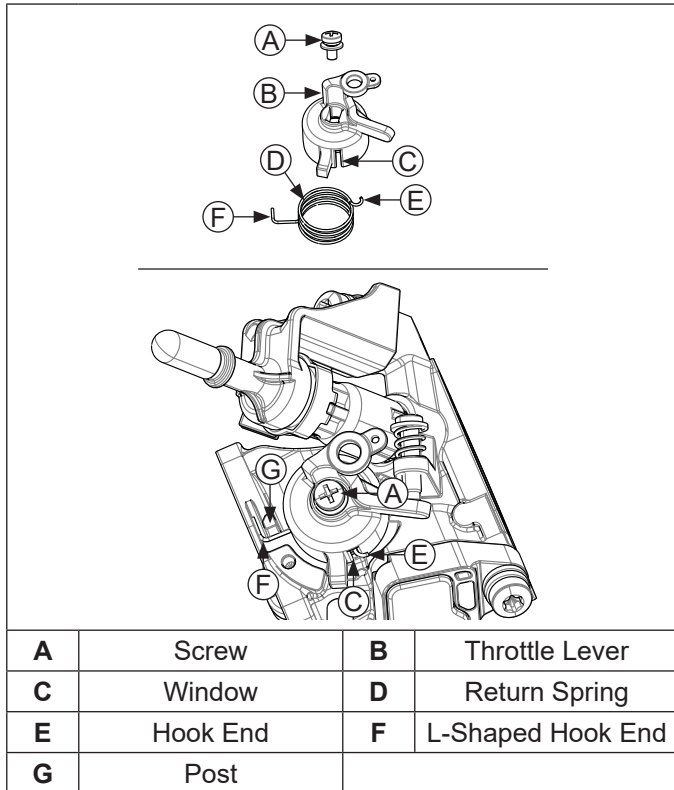

1. Remove screw, throttle lever, and return spring.
2. Insert hook end of return spring in window of throttle lever and hold in place.
3. Hold throttle plate closed while positioning L-shaped hook end of return spring on post; holding throttle lever at slight angle, install throttle lever/spring assembly onto throttle shaft. A slight clockwise spring load rotation is required to align lever onto shaft.

4. Check that hook is in upper 1/3 to 1/2 of window in throttle lever. If hook is further down in window, wire is bound and steps 2 and 3 should be repeated.

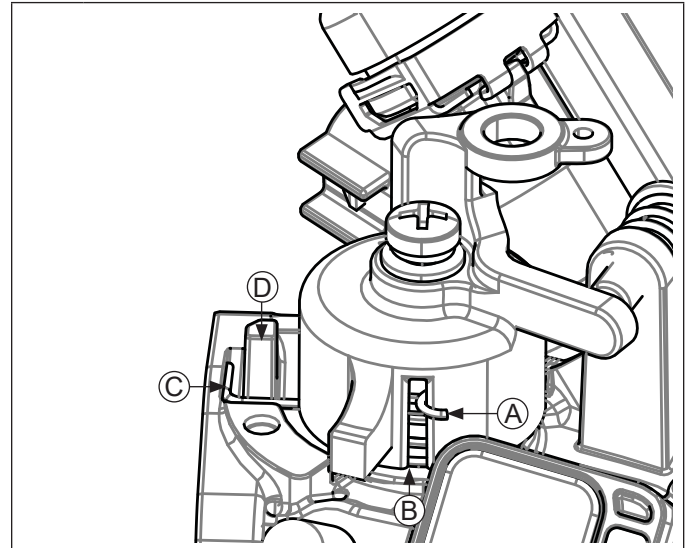

5. When hook end is in proper position, install screw to secure throttle lever to shaft. Torque screw to 1.3 N·m (11.5 in. lb.).

**TROUBLESHOOTING**

**Troubleshooting Guide**



Condition	Possible Cause
Engine Starts Hard or Fails to Start When Cold.	Fuel pump not running.
	Empty fuel tank.
	Faulty spark plug.
	Old/stale fuel.
	Incorrect fuel pressure.
	Crankshaft position sensor loose or faulty.
	TPS set incorrect (ECU Reset and TPS Learn).
	TPS faulty.
	Engine temperature sensor faulty.
	Faulty coil.
	Low system voltage.
	Faulty injector.
	Faulty battery.
	Loose or corroded connections.
Engine Starts Hard or Fails to Start When Hot.	Faulty spark plug.
	Fuel pump not running.
	Fuel pressure low.
	Insufficient fuel delivery.
	TPS set incorrect (ECU Reset and TPS Initialization).
	Crankshaft position sensor loose or faulty.
	TPS faulty.
	Engine temperature sensor faulty.
	Faulty injector.
Engine Stalls or Idles Roughly (cold or warm).	Faulty spark plug.
	Insufficient/excessive fuel delivery.
	TPS set incorrect.
	TPS faulty.
	Faulty engine temperature sensor.
Engine Misses, Hesitates, or Stalls Under Load.	Fuel injector, fuel filter, fuel line, or fuel pick-up dirty/restricted.
	Dirty air cleaner.
	Insufficient fuel pressure or fuel delivery.
	Vacuum (intake air) leak.
	Improper governor setting, adjustment or operation.
	TPS/TMAP faulty, mounting problem or TPS Initialization Procedure incorrect.
	Bad coil, spark plug, or wires.

# EFI SYSTEM

## Troubleshooting Guide

Condition	Possible Cause
Low Power	Faulty/malfunctioning ignition system.
	Dirty air filter.
	Insufficient fuel delivery.
	Improper governor adjustment.
	Plugged/restricted exhaust.
	Basic engine problem exists.
	TPS faulty or mounting exists.
	Throttle plate in throttle body not fully opening to WOT stop (if equipped).

### Function Test

	 <b>WARNING</b>
	High Pressure Fluids can puncture skin and cause severe injury or death.
	Do not work on fuel system without proper training or safety equipment.
Fluid puncture injuries are highly toxic and hazardous. If an injury occurs, seek immediate medical attention.	

Function of fuel system is to provide sufficient delivery of fuel at system operating pressure of 50 psi ± 3. If an engine starts hard, or turns over but will not start, it may indicate a problem with EFI fuel system. A quick test will verify if system is operating.

1. Disconnect and ground spark plug lead.
2. Complete all safety interlock requirements and crank engine for approximately 3 seconds.
3. Remove spark plug and check for fuel at tip.
  - a. If there is fuel at tip of spark plug fuel pump and injector are operating.
  - b. If there is no fuel at tip of spark plug, check following:
    1. Make sure fuel tank contains clean, fresh, proper fuel.
    2. Make sure that vent in fuel tank is open.
    3. Make sure fuel tank valve (if equipped) is fully opened.
    4. Make sure battery is supplying proper voltage.
    5. Check that fuses and fuel pump relay are good, and that no electrical or fuel line connections are damaged or broken.
    6. Test fuel pump operation as described in original equipment manufacturer's manual.

### Fault Codes

#### Example of Diagnostic Display

<p>★ ★ ★ ★ ★ ★ ★ ★ ★ ★ (0)</p> <p>One second pause</p> <p>★ (1)</p> <p>One second pause</p> <p>★ ★ ★ ★ ★ ★ ★ ★ ★ ★ (0)</p> <p>One second pause</p> <p>★ ★ ★ ★ ★ ★ ★ ★ (7)</p>	}	Fault Code 0107
<p>Three second pause</p> <p>★ ★ ★ ★ ★ ★ (6)</p> <p>One second pause</p> <p>★ (1)</p>	}	End Code 61

**Diagnostic Fault Code Summary**

Fault Code	Connection or Failure Description
0031	Oxygen Sensor Heater Circuit Low Voltage
0032	Oxygen Sensor Heater Circuit High Voltage
0107	Manifold Absolute Pressure (TMAP) Circuit Low Voltage or Open
0108	Manifold Absolute Pressure (TMAP) Circuit High Voltage
0112	Intake Air Temperature (TMAP) Circuit Low Voltage
0113	Intake Air Temperature (TMAP) Circuit High Voltage or Open
0117	Engine Temperature Sensor Circuit Low Voltage
0118	Engine Temperature Sensor Circuit High Voltage or Open
0122	Throttle Position Sensor Circuit Low Voltage or Open
0123	Throttle Position Sensor Circuit High Voltage
0131	Oxygen Sensor 1 Circuit Low Voltage, or Open
0132	Oxygen Sensor 1 Circuit High Voltage
0171	Maximum Adaptation Limit Exceeded
0172	Minimum Adaptation Limit Exceeded
0174	Lean Fuel Condition at High Load (Open Loop)
0201	Injector Circuit Malfunction
0230	Fuel Pump Relay Circuit Low Voltage or Open
0232	Fuel Pump Relay Circuit High Voltage
0336	Crankshaft Position Sensor Noisy Signal
0337	Crankshaft Position Sensor No Signal
0351	Ignition Coil Malfunction
0562	System Voltage Low
0563	System Voltage High
0650	MIL Circuit Malfunction
61	End of Code Transmission

**MIL Operation for Pedal Start Applications**

Key ON/MIL on for 3 seconds then turns off. MIL will remain off during normal operation or until a trouble code/fault is detected or until key switch is cycled power OFF for 15 seconds and returned to key ON position.

If code/fault is detected and is a current code, light will remain on for duration of operating cycle (key ON). If code/fault is temporarily detected and fault is recorded and then returns to normal, MIL will go out, but code is stored in ECU as a historic code.

**MIL Operation for Key Start Applications**

ECU continuously monitors engine operation against preset performance limits. If operation is outside limits, ECU activates MIL, if equipped, and stores a diagnostic code in its fault memory. If component or system returns to proper function, ECU will turn off MIL. If MIL stays illuminated, it warns customer a fault is currently happening, and dealer service is required. Upon receipt, dealer technician can access fault code(s) to help determine what portion of system is malfunctioning.

Codes are accessed through key switch and displayed as blinks or flashes of MIL. Access codes as follows:

1. Check that battery voltage is above 11 volts.
2. Start with key switch OFF.
3. Turn key switch to ON and OFF, then ON and OFF, then ON, leaving it on in third sequence. Do not start engine. Time between sequences must be less than 2.5 seconds.

4. MIL will blink a series of times. Number of times MIL blinks represents a number in fault code.
5. A sequence of four digits make up a fault code. There is a one (1) second pause between blinks of a fault code. There is a three (3) second pause between separate fault codes. After fault code(s) are blinked a two digit 61 is blinked to indicate program has completed. Zero (0) = ten (10) blinks.
  - a. It's a good idea to write down codes as they appear, as they may not be in numerical sequence.
  - b. Code 61 will always be last code displayed, indicating end of code transmission. If code 61 appears immediately, no other fault codes are present.

After problem has been corrected, fault codes may be cleared by following ECU Reset and TPS Learn Procedures.

Diagnostic Fault Code Summary lists fault codes, and what they correspond to. Diagnostic Code Summary is a list of individual codes with an explanation of what triggers them, what symptoms might be expected, and probable causes.

# EFI SYSTEM

## Diagnostic Code Summary

### Code 0031

NOTE: Codes 0031 and 0032 may have been mistakenly activated by turning key ON with oxygen sensor disconnected. If either code status is historic, that code may have set during assembly or a previous repair and may not be related to current event. Clear codes and retest to confirm. If code status is current, refer to Oxygen Sensor (O2) earlier in this section, to test and troubleshoot.

Component:	Oxygen Sensor Heater
Fault:	O2S Heater Circuit Low Voltage
Condition:	System voltage too low, open connection or faulty sensor.
Conclusion:	<p>Engine Wiring Harness Related</p> <ul style="list-style-type: none"> <li>● Pin circuit wiring or connectors. ECU black pin 7 or broken wire.</li> </ul> <p>Oxygen Sensor Related</p> <ul style="list-style-type: none"> <li>● Sensor connector or wiring problem.</li> </ul> <p>Poor system ground from ECU to engine or battery to engine.</p>

### Code 0032

NOTE: Codes 0031 and 0032 may have been mistakenly activated by turning key ON with oxygen sensor disconnected. If either code status is historic, that code may have set during assembly or a previous repair and may not be related to current event. Clear codes and retest to confirm. If code status is current, refer to Oxygen Sensor (O2) earlier in this section, to test and troubleshoot.

Component:	Oxygen Sensor Heater
Fault:	O2S Heater Circuit High Voltage
Condition:	System voltage too high, shorted connection or faulty sensor.
Conclusion:	<p>Oxygen Sensor Related</p> <ul style="list-style-type: none"> <li>● Sensor connector or wiring problem.</li> <li>● Sensor damaged.</li> <li>● Pin circuit wiring or connectors at Black 7.</li> </ul> <p>ECU Related</p> <ul style="list-style-type: none"> <li>● ECU-to-harness connection problem.</li> </ul>

### Code 0107

Component:	Manifold Absolute Pressure (TMAP)
Fault:	MAP Circuit Low Voltage or Open
Condition:	Throttle body leak, open connection or faulty sensor.
Conclusion:	<p>TMAP Sensor Related</p> <ul style="list-style-type: none"> <li>● Sensor malfunction.</li> <li>● Vacuum leaks from loose throttle body or sensor.</li> </ul> <p>Wire Harness Related</p> <ul style="list-style-type: none"> <li>● Poor grounding or open circuit.</li> <li>● Wire harness and connectors loose, damaged or corroded.</li> <li>● Pin circuit wiring or connectors at Black 10, 11 and 16.</li> </ul> <p>Bad TPS Learn.</p>

### Code 0108

Component:	Manifold Absolute Pressure (TMAP)
Fault:	MAP Circuit High Voltage
Condition:	Throttle body leak, shorted connection or faulty sensor.
Conclusion:	<p>TMAP Sensor Related</p> <ul style="list-style-type: none"> <li>● Sensor malfunction.</li> <li>● Vacuum leaks from loose throttle body or sensor.</li> </ul> <p>Wire Harness Related</p> <ul style="list-style-type: none"> <li>● Poor grounding.</li> <li>● Pin circuit wiring or connectors at Black 11.</li> </ul> <p>Bad TPS Learn.</p>

**Code 0112**

Component:	Intake Air Temperature (TMAP)
Fault:	Intake Air Temperature Sensor Circuit Low Voltage
Condition:	Shorted connection, faulty sensor or shorted wire.
Conclusion:	<p>TMAP Sensor Related</p> <ul style="list-style-type: none"> <li>• Sensor wiring or connection.</li> </ul> <p>Engine Wiring Harness Related</p> <ul style="list-style-type: none"> <li>• Pin circuits Black 10 and Black 8 may be damaged or routed near noisy signal (coil, alternator, etc.).</li> <li>• ECU-to-harness connection problem.</li> </ul>

**Code 0117**

Component:	Engine Temperature Sensor
Fault:	Engine Temperature Sensor Circuit Low Voltage
Condition:	Shorted connection, faulty sensor or shorted wire.
Conclusion:	<p>Temperature Sensor Related</p> <ul style="list-style-type: none"> <li>• Sensor wiring or connection.</li> </ul> <p>Engine Wiring Harness Related</p> <ul style="list-style-type: none"> <li>• Pin circuits Black 10 and Black 14 maybe damaged or routed near noisy signal (coils, stator, etc.).</li> <li>• ECU-to-harness connection problem.</li> </ul>

**Code 0113**

Component:	Intake Air Temperature (TMAP)
Fault:	Intake Air Temperature Sensor Circuit High Voltage or Open
Condition:	Shorted connection, faulty sensor, broken wire or connection.
Conclusion:	<p>TMAP Related</p> <ul style="list-style-type: none"> <li>• Sensor wiring or connection.</li> </ul> <p>Engine Wiring Harness Related</p> <ul style="list-style-type: none"> <li>• Pin circuits ECU Black pin 10 and 8 may be damaged.</li> <li>• ECU-to-harness connection problem or broken wire.</li> </ul>

**Code 0118**

Component:	Engine Temperature Sensor
Fault:	Engine Temperature Sensor Circuit High Voltage or Open
Condition:	Shorted connection, faulty sensor, open connection or broken wire.
Conclusion:	<p>Temperature Sensor Related</p> <ul style="list-style-type: none"> <li>• Sensor wiring or connection.</li> </ul> <p>Engine Wiring Harness Related</p> <ul style="list-style-type: none"> <li>• Pin circuits ECU Black pin 10 and 14 may be damaged.</li> <li>• ECU-to-harness connection problem or broken wire.</li> </ul> <p>System Related</p> <ul style="list-style-type: none"> <li>• Engine is operating above 176°C (350°F) temperature sensor limit.</li> </ul>

# EFI SYSTEM

## Code 0122

Component:	Throttle Position Sensor (TPS)
Fault:	TPS Circuit Low Voltage or Open
Condition:	Open connection, broken wire or faulty sensor.
Conclusion:	<p>TPS Related</p> <ul style="list-style-type: none"> <li>● TPS bad or worn internally.</li> </ul> <p>Engine Wiring Harness Related</p> <ul style="list-style-type: none"> <li>● Broken or shorted wire in harness. <ul style="list-style-type: none"> <li>ECU Black pin 10 to TPS pin B.</li> <li>ECU Black pin 12 to TPS pin A.</li> <li>ECU Black pin 16 to TPS pin C.</li> </ul> </li> </ul> <p>Throttle Body Related</p> <ul style="list-style-type: none"> <li>● Throttle shaft inside TPS worn, broken, or damaged.</li> <li>● Throttle plate loose or misaligned.</li> <li>● Throttle plate bent or damaged allowing extra airflow past, or restricting movement.</li> </ul> <p>ECU Related</p> <ul style="list-style-type: none"> <li>● Circuit providing voltage or ground to TPS damaged.</li> <li>● TPS signal input circuit damaged.</li> </ul>

## Code 0123

Component:	Throttle Position Sensor (TPS)
Fault:	TPS Circuit High Voltage
Condition:	Shorted connection or faulty sensor.
Conclusion:	<p>TPS Sensor Related</p> <ul style="list-style-type: none"> <li>● Sensor connector or wiring.</li> <li>● Sensor output affected or disrupted by dirt, grease, oil, wear.</li> <li>● Sensor loose on throttle body.</li> </ul> <p>Throttle Body Related</p> <ul style="list-style-type: none"> <li>● Throttle shaft or bearings worn/damaged.</li> </ul> <p>Engine Wiring Harness Related</p> <ul style="list-style-type: none"> <li>● ECU pins Black 10, 12 and 16 damaged (wiring, connectors).</li> <li>● ECU pins Black 10, 12 and 16 routed near noisy electrical signal (coil, alternator).</li> <li>● Intermittent 5 volt source from ECU (pin Black 16).</li> <li>● ECU-to-harness connection problem.</li> </ul>

## Code 0131

Component:	Oxygen Sensor
Fault:	O2S 1 Circuit Low Voltage
Condition:	Open connection, broken wire or faulty sensor.
Conclusion:	<p>Oxygen Sensor Related</p> <ul style="list-style-type: none"> <li>● Sensor connector or wiring problem.</li> <li>● Sensor contaminated, corroded or damaged.</li> <li>● Poor ground path.</li> <li>● Pin circuit wiring or connectors. <ul style="list-style-type: none"> <li>ECU Black pin 10 or 17.</li> </ul> </li> </ul> <p>TPS Learn Procedure Incorrect</p> <ul style="list-style-type: none"> <li>● Lean condition (check oxygen sensor signal with VOA and refer to Oxygen Sensor section).</li> </ul> <p>Engine wiring harness related such as a cut wire, broken or pinched.</p>

## Code 0132

Component:	Oxygen Sensor
Fault:	O2S 1 Circuit High Voltage
Condition:	Shorted connection or faulty sensor.
Conclusion:	<p>Oxygen Sensor Related</p> <ul style="list-style-type: none"> <li>● Sensor connector or wiring problem.</li> <li>● Sensor contaminated or damaged.</li> <li>● Poor ground path.</li> <li>● Pin circuit wiring or connectors. <ul style="list-style-type: none"> <li>ECU Black pin 10 or Black pin 17.</li> </ul> </li> </ul> <p>Engine Wiring Harness Related</p> <ul style="list-style-type: none"> <li>● Difference in voltage between sensed voltage and actual sensor voltage.</li> <li>● Short in wire harness.</li> </ul>

**Code 0171**

Component:	Fuel System
Fault:	Maximum adaptation limit exceeded
Condition:	Fuel inlet screen/filter plugged, low pressure at high pressure fuel line, TPS malfunction, shorted connection, faulty sensor, low fuel or wrong fuel type.
Conclusion:	<p>Oxygen Sensor Related</p> <ul style="list-style-type: none"> <li>● Corrosion or poor connection.</li> <li>● Sensor contaminated or damaged.</li> <li>● Air leak into exhaust.</li> <li>● Poor ground path.</li> <li>● Pin circuit wiring or connectors. ECU Black pin 10 or Black pin 17.</li> </ul> <p>TPS Sensor Related</p> <ul style="list-style-type: none"> <li>● Throttle plate position incorrect during Learn procedure.</li> <li>● TPS problem or malfunction.</li> </ul> <p>Engine Wiring Harness Related</p> <ul style="list-style-type: none"> <li>● Difference in voltage between sensed voltage and actual sensor voltage.</li> <li>● Problem in wiring harness.</li> <li>● ECU-to-harness connection problem.</li> </ul> <p>Systems Related</p> <ul style="list-style-type: none"> <li>● Ignition (spark plug, plug wire, ignition coil).</li> <li>● Fuel (fuel type/quality, injector, fuel pressure too low, fuel pump).</li> <li>● Combustion air (air cleaner dirty/restricted, intake leak, throttle bore).</li> <li>● Base engine problem (rings, valves).</li> <li>● Exhaust system leak (muffler, flange, oxygen sensor mounting boss, etc.).</li> <li>● Fuel in crankcase oil.</li> </ul>

**Code 0172**

Component:	Fuel System
Fault:	Minimum adaptation limit exceeded
Condition:	Too high pressure at high pressure fuel line, TPS malfunction, shorted connection, faulty sensor or fuel pump failure.
Conclusion:	<p>Oxygen Sensor Related</p> <ul style="list-style-type: none"> <li>● Sensor connector or wiring.</li> <li>● Sensor contaminated or damaged.</li> <li>● Poor ground path.</li> <li>● Pin circuit wiring or connectors. ECU Black pin 10 or 17.</li> </ul> <p>TPS Sensor Related</p> <ul style="list-style-type: none"> <li>● Throttle plate position incorrect during Learn procedure.</li> <li>● TPS problem or malfunction.</li> </ul> <p>Engine Wiring Harness Related</p> <ul style="list-style-type: none"> <li>● Difference in voltage between sensed voltage and actual sensor voltage.</li> <li>● Problem in wiring harness.</li> <li>● ECU-to-harness connection problem.</li> </ul> <p>Systems Related</p> <ul style="list-style-type: none"> <li>● Ignition (spark plug, plug wire, ignition coil).</li> <li>● Fuel (fuel type/quality, injector, fuel pressure too high, fuel pump).</li> <li>● Combustion air (air cleaner dirty/restricted).</li> <li>● Base engine problem (rings, valves).</li> <li>● Fuel in crankcase oil.</li> </ul>



# EFI SYSTEM

## Code 0174

Component:	Fuel System
Fault:	Lean fuel condition
Condition:	Fuel inlet screen/filter plugged, low pressure at high pressure fuel line, TPS malfunction, shorted connection or faulty sensor.
Conclusion:	<p>TPS Learn Incorrect</p> <ul style="list-style-type: none"> <li>Lean condition (check oxygen sensor signal with VOA and refer to Oxygen Sensor).</li> </ul> <p>Engine Wiring Harness Related</p> <ul style="list-style-type: none"> <li>Pin circuit wiring or connectors. ECU pin Black 10, 12, 16 and 17.</li> </ul> <p>Low Fuel Pressure</p> <ul style="list-style-type: none"> <li>Plugged filters.</li> </ul> <p>Oxygen Sensor Related</p> <ul style="list-style-type: none"> <li>Sensor connector or wiring problem.</li> <li>Exhaust leak.</li> <li>Poor ground.</li> </ul> <p>Poor system ground from ECU to engine, causing rich running while indicating lean.</p> <p>Fuel pump connection. Refer to equipment manufacturer's manual for information.</p>

## Code 0201

Component:	Fuel Injector
Fault:	Injector Circuit Malfunction
Condition:	Injector damaged or faulty, shorted or open connection.
Conclusion:	<p>Injector Related</p> <ul style="list-style-type: none"> <li>Injector coil shorted or opened.</li> </ul> <p>Engine Wiring Harness Related</p> <ul style="list-style-type: none"> <li>Broken or shorted wire in harness. ECU pin Black 5.</li> <li>Wiring from Ignition.</li> </ul> <p>ECU Related</p> <ul style="list-style-type: none"> <li>Circuit controlling injector damaged.</li> </ul>

## Code 0230

Component:	Fuel Pump Relay
Fault:	Circuit Low Voltage or Open
Condition:	Shorted or open connection.
Conclusion:	<p>Fuel Pump Relay Related</p> <ul style="list-style-type: none"> <li>Fuel pump relay open or shorted internally.</li> </ul> <p>Engine Wiring Harness related</p> <ul style="list-style-type: none"> <li>Broken or shorted wire in harness. ECU pin Black 9 or Grey 17.</li> </ul> <p>ECU Related</p> <ul style="list-style-type: none"> <li>ECU is damaged.</li> </ul>

## Code 0232

Component:	Fuel Pump Relay
Fault:	Circuit High Voltage
Condition:	Shorted connection.
Conclusion:	<p>Fuel Pump Relay Related</p> <ul style="list-style-type: none"> <li>Fuel pump damaged internally.</li> </ul> <p>Charging Output System Too High.</p>

**Code 0336**

Component:	Crankshaft Position Sensor
Fault:	Crankshaft Position Sensor Noisy Signal
Condition:	Loose sensor, faulty/bad battery, shorted or faulty connection, faulty sensor or faulty sensor grounding.
Conclusion:	<p>Crankshaft Position Sensor Related</p> <ul style="list-style-type: none"> <li>● Sensor connector or wiring.</li> <li>● Sensor loose.</li> </ul> <p>Crankshaft Position Sensor Wheel Related</p> <ul style="list-style-type: none"> <li>● Damaged teeth.</li> <li>● Gap section not registering.</li> </ul> <p>Engine Wiring Harness Related</p> <ul style="list-style-type: none"> <li>● Pin circuit wiring or connectors. ECU pin Black 4 and Black 13.</li> <li>● ECU-to-harness connection problem.</li> </ul> <p>Ignition System Related</p> <ul style="list-style-type: none"> <li>● Non-resistor spark plug used.</li> <li>● Faulty or disconnected ignition coil or secondary lead.</li> </ul>

**Code 0337**

NOTE: If fault code P0337 is present and engine does not start/run, proceed to step 1 of Crankshaft Position Sensor earlier in this section. If P0337 is present and engine operates, clear codes and retest.

Component:	Crankshaft Position Sensor
Fault:	Crankshaft Position Sensor No Signal
Condition:	Loose sensor, open or shorted connection (sensor connector or battery connections) or faulty sensor.
Conclusion:	<p>Crankshaft Position Sensor Related</p> <ul style="list-style-type: none"> <li>● A false fault code P0337 is triggered by a voltage drop with key ON and engine off. Voltage drop may be caused by a poor/inadequate battery connection, battery charger connected or disconnected, or any event that may interrupt voltage signal to ECU like a power interruption or heavy load from equipment that results in a recordable voltage drop.</li> <li>● Sensor connector or wiring.</li> <li>● Sensor loose.</li> </ul> <p>Crankshaft Position Sensor Wheel Related</p> <ul style="list-style-type: none"> <li>● Damaged teeth.</li> </ul> <p>Engine Wiring Harness Related</p> <ul style="list-style-type: none"> <li>● Pin circuit wiring or connectors. ECU pin Black 4 or Black 13.</li> <li>● ECU-to-harness connection problem.</li> </ul> <p>If code is stored in fault history and starts normally. Clear code, no other service required.</p>

# EFI SYSTEM

## Code 0351

Component:	Ignition Coil
Fault:	Ignition Coil Malfunction
Condition:	Broken wire in harness (may not be visible), shorted connection or faulty sensor.
Conclusion:	<p>Engine Wiring Harness Related</p> <ul style="list-style-type: none"> <li>● Connection to ignition or fuse.</li> <li>● Pin circuit wiring or connectors.</li> <li>● ECU pin Black 1.</li> <li>● ECU-to-harness connection problem.</li> </ul> <p>Ignition System Related</p> <ul style="list-style-type: none"> <li>● Incorrect spark plug used.</li> <li>● Poor connection to spark plug.</li> </ul>

## Code 0562

Component:	System Voltage
Fault:	System Voltage Low
Condition:	Bad fuse or shorted connection.
Conclusion:	<p>Corroded Connections</p> <p>Bad Battery*</p> <ul style="list-style-type: none"> <li>● Low output charging system.*</li> <li>● Bad or missing fuse.*</li> </ul> <p>*Refer to equipment manufacturer's manual for information.</p>

## Code 0563

Component:	System Voltage
Fault:	System Voltage High
Condition:	Shorted connection.
Conclusion:	<p>Bad Battery.*</p> <ul style="list-style-type: none"> <li>● Low output charging system.*</li> </ul> <p>*Refer to equipment manufacturer's manual for information.</p>

## Code 0650

Component:	MIL Circuit
Fault:	MIL Circuit Malfunction
Condition:	Failure in MIL circuit detected.
Conclusion:	<p>Bad Connection.</p> <p>Broken Wire.</p> <p>Bad ECU.</p>

## Code 61

Component:	End of Code Transmission
------------	--------------------------

## Troubleshooting Flow Chart

Following a flow chart provides an alternative method of troubleshooting EFI system. Chart will enable you to review entire system in about 10-15 minutes. Using chart, accompanying diagnostic aids (listed chart), and any signaled fault codes, you should be able to quickly locate any problems within system.

EFI Diagnostic Flow Diagram

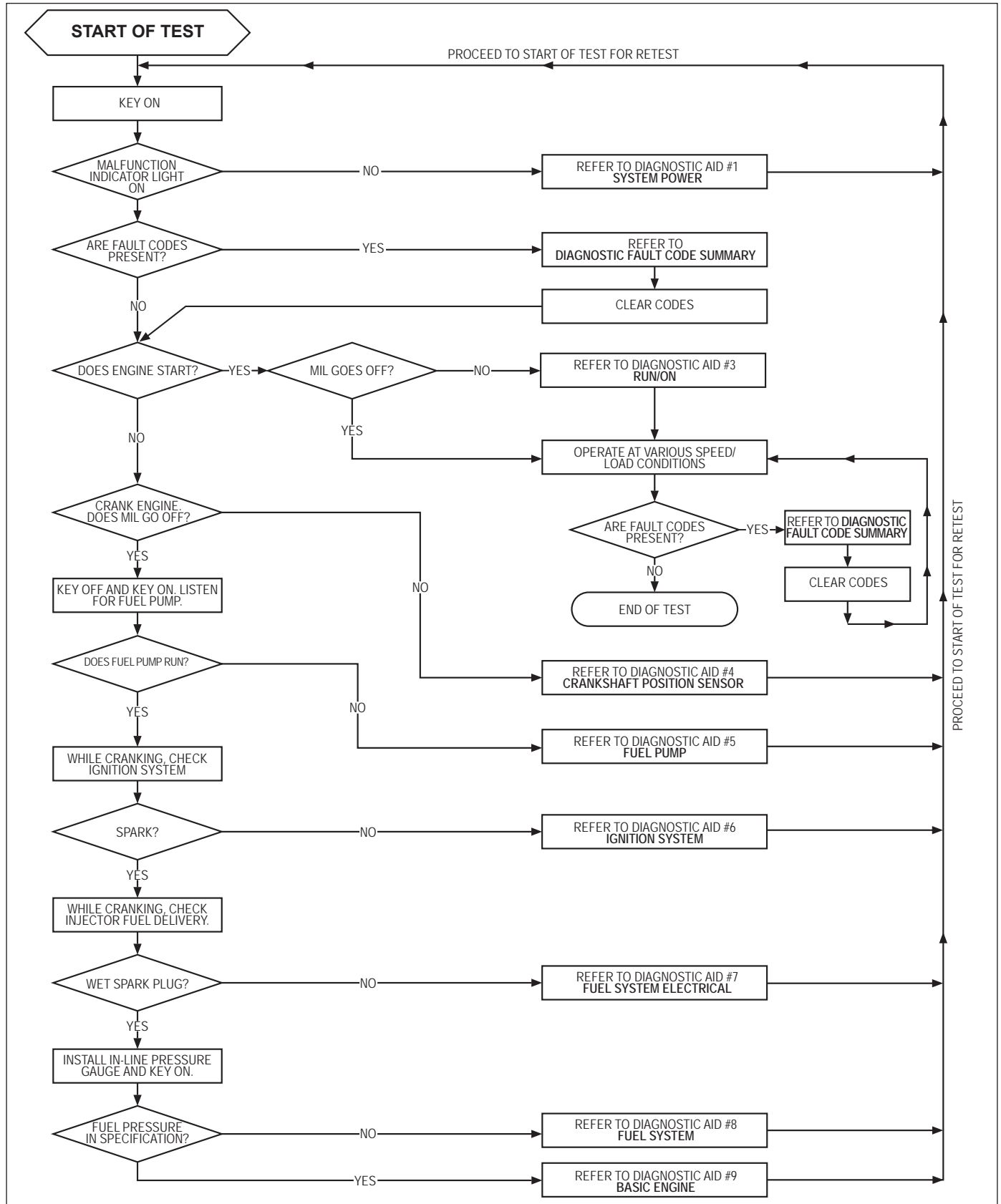

# EFI SYSTEM

## Flow Chart Diagnostic Aids

### Diagnostic Aid #1 SYSTEM POWER

(MIL does not illuminate for 3 seconds when key is first turned ON)

NOTE: MIL is installed by vehicle OEM. Twelve volt supply to bulb will be part of vehicle wire harness. Review **MIL Operation for Pedal Start Applications** or **MIL Operation for Key Start Applications** earlier in this section.

#### Conclusion

- Battery
- Main system fuse
- MIL light bulb burned out
- MIL electrical circuit problem  
Pin circuits Grey 3.
- Ignition switch
- Permanent ECU power circuit problem  
Pin circuit Black 18.
- Switched ECU power circuit problem  
Pin circuit Black 15.
- ECU grounds
- ECU

### Diagnostic Aid #2 FAULT CODES

Refer to Diagnostic Fault Code Summary.

NOTE: If fault code P0337 is present and engine does not start/run, proceed to step 1 of Crankshaft Position Sensor earlier in this section. If P0337 is present and engine operates, clear codes and retest.

### Diagnostic Aid #3 RUN/ON

(MIL remains ON while engine is running)

#### Conclusion

- All current fault codes will turn on MIL when key is ON or engine is running.
- If MIL is on and no fault codes are active, check MIL wiring between ECU and bulb.

### Diagnostic Aid #4 CRANKSHAFT POSITION SENSOR

(MIL does not turn off during cranking)

#### Condition

- Crankshaft position sensor
- Crankshaft position sensor circuit problem, pin circuits Black 4 and Black 13.
- Crankshaft position sensor/toothed wheel air gap
- Toothed wheel
- Flywheel key sheared
- ECU

### Diagnostic Aid #5 FUEL PUMP

(fuel pump not turning on)

#### Condition

- Inspect fuse(s)
- Fuel pump relay circuit problem, pin circuits Black 9 and Grey 17.
- Fuel pump

### Diagnostic Aid #6 IGNITION SYSTEM

(no spark)

#### Condition

- Spark plug
- Plug wire
- Coil
- Coil circuit, pin circuits Grey 10 and Black 1.
- ECU grounds
- ECU
- Vehicle safety interlocks, refer to equipment manufacturer's manual

### Diagnostic Aid #7 FUEL SYSTEM ELECTRICAL

(no fuel delivery)

#### Condition

- No fuel
- Air in high pressure fuel line
- Fuel filter/line plugged
- Injector circuit, pin circuits Black 5 and Black 6
- Injector
- ECU grounds
- ECU

### Diagnostic Aid #8 FUEL SYSTEM

(fuel pressure)

#### Low Fuel Pressure-Condition

- No fuel
- Fuel filter(s) plugged
- Fuel supply line plugged
- Fuel pump - internally plugged
- Pressure regulator not functioning properly inside fuel pump.

### Diagnostic Aid #9 BASIC ENGINE

(cranks but will not run)

#### Condition

- Refer to basic engine troubleshooting charts within Troubleshooting and/or refer to equipment manufacturer's manual.

## **GOVERNOR (OEM Supplied)**

Refer to operating instructions of equipment this engine powers for specific governor instructions.

# Lubrication System

These engines use a splash lubrication system, supplying necessary lubrication to crankshaft, camshaft, connecting rod and valve train components.

## Lubrication Components

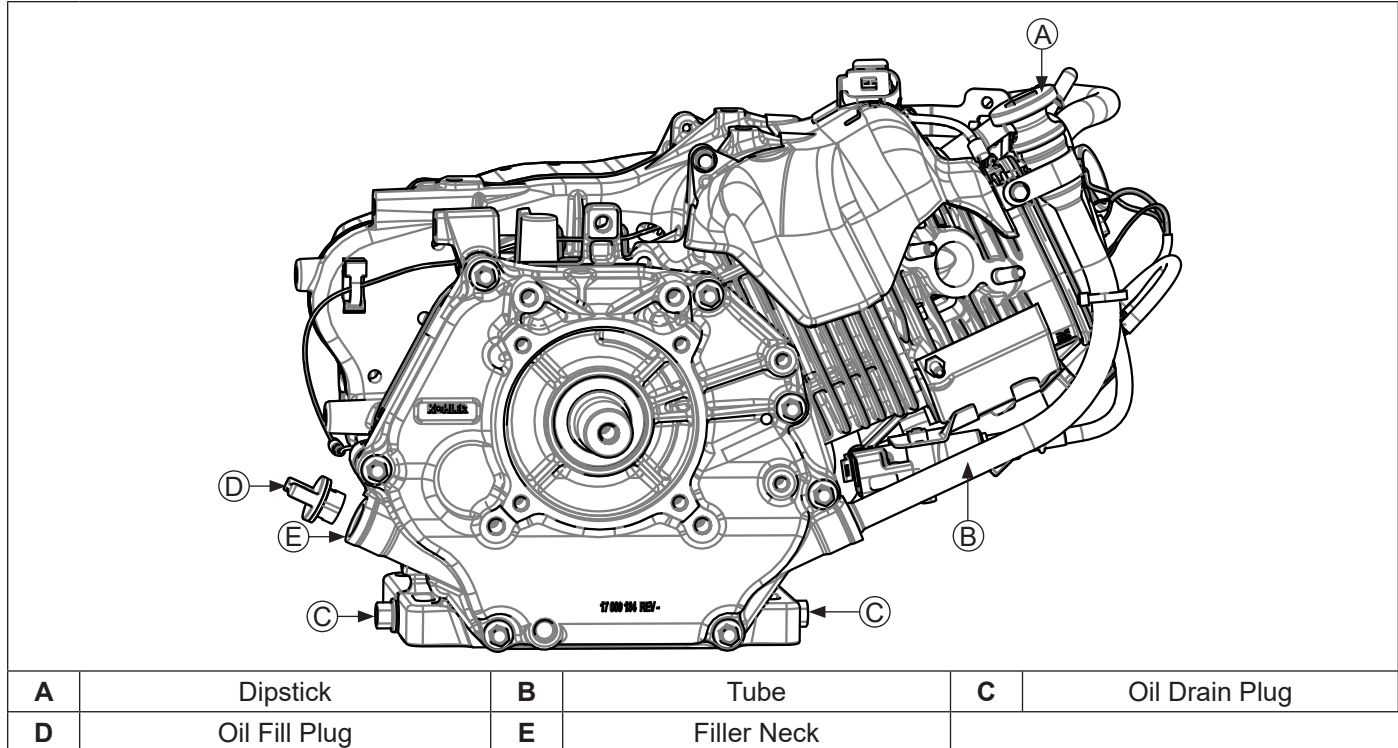

## WINTER LUBRICATION

If engine is frequently used for short periods of time in ambient temperatures below 4°C (40°F), reduce oil change intervals to every 25 hours.

A rise in oil level during cold weather operation can indicate contaminants collecting in crankcase. If oil level begins to rise:

1. Run vehicle longer to bring engine up to operating temperature before shutting it off. Continuous running for a period of 30 minutes will stabilize engine temperatures.
2. Change oil if oil level begins to rise over full mark on dipstick.
3. Monitor oil level and if it continues to rise, discontinue use and contact your dealer.

**NOTE:** As ambient weather temperatures decrease below 4°C (40°F), more frequent oil changes may be required. Water vapor is a normal by-product of combustion in any engine. During cold weather operation, some water vapor condenses into liquid form on cool metal surfaces inside engine. In cold weather, this water will accumulate and become mixed with engine oil. In addition to water vapor in cold conditions, liquid fuel can pass by piston rings and accumulate in engine oil. Emulsified fluids in oil can give the oil a cloudy or milky appearance.

If engine is run at normal operating temperatures, most of this water and fuel will become vapor and will be passed through breather.

## OIL RECOMMENDATIONS

Refer to Maintenance.

### CHECK OIL LEVEL

**NOTE:** To prevent extensive engine wear or damage, never run engine with oil level below or above operating range indicator on dipstick.

Ensure engine is cool and level. Clean oil fill/dipstick areas of any debris.

1. Check oil level using dipstick or oil fill plug.
  - a. Push-on cap dipstick: Remove dipstick; wipe oil off. Reinsert dipstick into tube; press down completely. Remove dipstick; check oil level. Level should be at top of indicator on dipstick.
  - or
  - b. Remove oil fill plug. Level should be up to point of overflowing filler neck.
2. If oil is low, add oil up to top of indicator mark on dipstick or to point of overflowing filler neck.
3. Reinstall and secure dipstick or oil fill plug.

### CHANGE OIL

Change oil while engine is warm.

1. Clean area around oil fill plug/dipstick and drain plug.
2. Remove drain plug and oil fill plug/dipstick. Drain oil completely.
3. Reinstall drain plug. Torque to 18 N·m (13 ft. lb.).

4. Fill crankcase with new oil, up to point of overflowing filler neck.
5. Reinstall oil fill plug/dipstick and tighten securely.
6. Dispose of used oil in accordance with local ordinances.

### OIL SENTRY™ (if equipped)

This switch is designed to prevent engine from starting in a low oil or no oil condition. Oil Sentry™ may not shut down a running engine before damage occurs. In some applications this switch may activate a warning signal. Read your equipment manuals for more information.

### Oil Sentry™ Oil Level Sensor Switch Testing (if equipped)

Some engines are equipped with an oil level sensor switch. This switch is connected to equipment through 8-pin customer connector. It provides a switching mechanism using continuity to indicate a safe operating oil level.

No continuity from switch indicates a safe (full) operating oil level.

Continuity from switch indicates a unsafe (low) operating oil level.

Review these troubleshooting guidelines.

1. Set an ohmmeter to Rx1 scale and zero meter. Connect one ohmmeter lead to Oil Sentry™ oil level switch lead (yellow with green sleeve) and touch other lead to a bare spot on crankcase (ground). Drain oil from crankcase and repeat test.

With oil at proper level, no continuity should have been indicated. After oil was drained, continuity should have been indicated.

Condition	Conclusion
No continuity indicated.	Remove closure plate from engine and remove oil level switch for further testing (steps 1a and 1b).

- a. If continuity was indicated with and without oil above, check if insulation has been scraped off oil level switch lead.

Condition	Conclusion
Lead wire is bare.	Allowing it to short, repair with electrical tape or replace oil level switch.

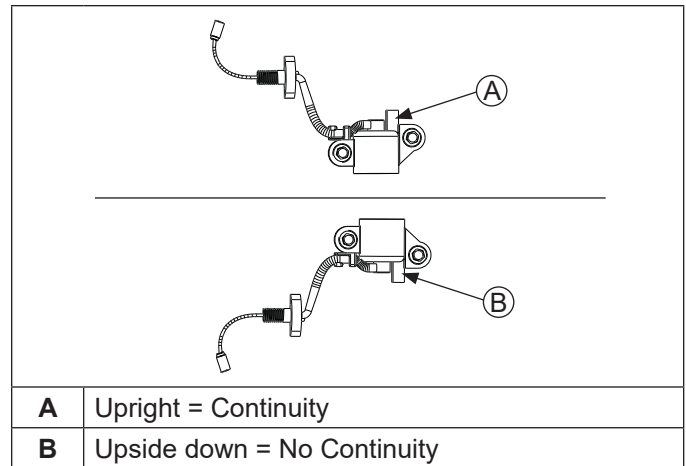



- b. With oil level switch removed, connect one ohmmeter lead to oil level switch lead terminal and connect other lead to mounting bracket. Test resistance with switch in normal position and inverted. Repeat test 2 or 3 times in each direction.

Condition	Conclusion
Switch continuity should be as indicated.	If not, replace it.



# Electrical System

## BATTERY CHARGING SYSTEM (OEM Supplied)

	 <b>CAUTION</b>
	Electrical Shock can cause injury. Do not touch wires while engine is running.

Engines in this application have an original equipment manufacturer (OEM) supplied starter generator. Refer to OEM manual for starter generator charging system troubleshooting information.

### Battery

A 12-volt battery with 400 cold cranking amps (cca) is generally recommended for starting in all conditions. A smaller capacity battery is often sufficient if an application is started only in warmer temperatures. Refer to following table for minimum capacities based on anticipated ambient temperatures. Actual cold cranking requirement depends on engine size, application, and starting temperatures. Cranking requirements increase as temperatures decrease and battery capacity shrinks. Refer to operating instructions of equipment for specific battery requirements.

### Battery Size Recommendations

Temperature	Battery Required
Above 32°F (0°C)	300 cca minimum
0°F to 32°F (-18°C to 0°C)	300 cca minimum
-5°F to 0°F (-21°C to -18°C)	300 cca minimum
-10°F (-23°C) or below	400 cca minimum

If battery charge is insufficient to turn over engine, recharge battery.

### Battery Maintenance

Regular maintenance is necessary to prolong battery life.

### Battery Test

To test battery, follow manufacturer's instructions.

## FUSES

This engine has 2 blade type automotive fuses. Replacement fuses must have same rating as blown fuse. Use fuse chart below to determine correct fuse.

Wire Color	Fuse Rating
1 Red Wire w/Black Stripe	10-amp Fuse
1 Red Wire w/White Stripe	
2 Red Wires	10-amp Fuse

### Fuse Replacement

1. Shut engine off and remove key.
2. Locate fuse holders.
3. Remove fuse cover and pull out fuse holder. Inspect condition of fuse holder.
4. Inspect fuse for a solid fusible link or a broken fusible link. Replace fuse if fusible link is broken. If you are not sure if fusible link is broken, replace fuse.

5. Insert fuse into fuse holder until it is seated properly. Install fuse cover.
6. If replacement fuse fails, there is a problem within circuit. Diagnostics are required. Identify which circuit is affected (see EFI System for electrical schematic) by identifying failed fuse/circuit. Perform troubleshooting procedures appropriate for circuit fuse that failed.
7. Install fuse holder into fuse cover.

## IGNITION SYSTEM

### Spark Plug

#### Component and Details

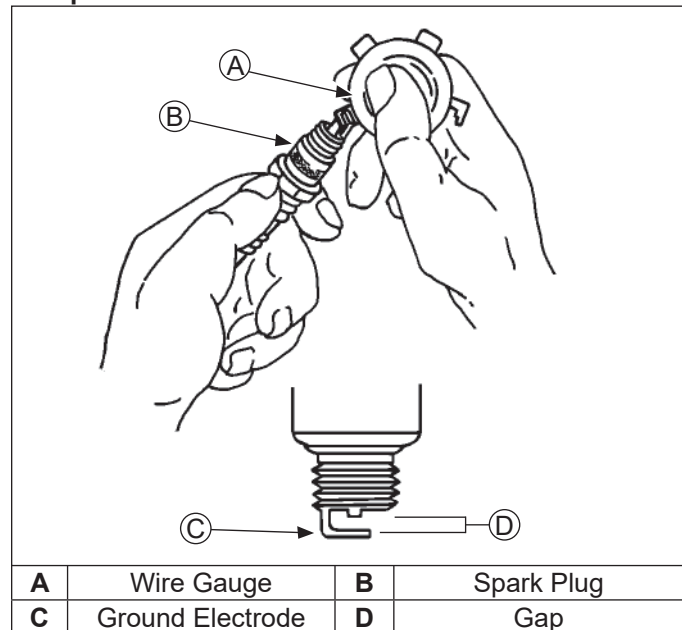

**NOTE:** Do not clean spark plug in a machine using abrasive grit. Some grit could remain in spark plug and enter engine causing extensive wear and damage.

Engine misfire or starting problems are often caused by a spark plug that has improper gap or is in poor condition.

Engine is equipped with following spark plug:

Gap	1.11 mm (0.044 in.)
Thread Size	14 mm
Reach	19.1 mm (3/4 in.)
Hex Size	15.9 mm (5/8 in.)

Refer to Maintenance for Repairs/Service Parts.

### Service

Clean out spark plug recess. Remove plug and replace.

1. Check gap using wire feeler gauge. Adjust gap to 1.11 mm (0.044 in.).
2. Install plug into cylinder head.
3. Torque plug to 27 N·m (20 ft. lb.).

## Inspection

Inspect spark plug as it is removed from cylinder head. Deposits on tip are an indication of general condition of piston rings, valves, and fuel mixture.

Normal and fouled plugs are shown in following photos:

### Normal

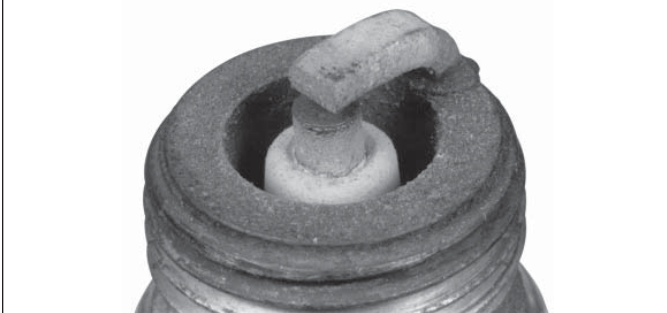

Plug taken from an engine operating under normal conditions will have light tan or gray colored deposits. If center electrode is not worn, plug can be set to proper gap and reused.

### Worn



On a worn plug, center electrode will be rounded and gap will be greater than specified gap. Replace a worn spark plug immediately.

### Wet Fouled



A wet plug is caused by excess fuel or oil in combustion chamber. Excess fuel could be caused by a restricted air cleaner, a fuel mixture problem. Oil in combustion chamber is usually caused by a restricted air cleaner, a breather problem, worn piston rings, or valve guides.

### Carbon Fouled



Soft, sooty, black deposits indicate incomplete combustion caused by a restricted air cleaner, over rich fuel mixture, weak ignition, or poor compression.

### Overheated



Chalky, white deposits indicate very high combustion temperatures. This condition is usually accompanied by excessive gap erosion. Lean fuel mixture settings, an intake air leak, or incorrect spark timing are normal causes for high combustion temperatures.

# Electrical System

## Troubleshooting Guide

### Test Ignition System

Isolate and verify trouble is within engine.

1. If Kohler diagnostic software is available, review "Safety System Active" status in Data Display screen. If yes is displayed, equipment safety circuit is active (Refer to equipment manufacturer's manual for safety system information). This must be corrected prior to continuing testing.

Condition	Possible Cause	Conclusion
Problem goes away.	Electrical System	Check key switch, wires, connections, safety interlocks, etc.
Problem persists.	Ignition or Electrical System	Inspect wiring harness (primary and secondary) for any obvious issues. Testing of ignition coil is required. Refer to EFI System, Ignition Coil Testing for details.

### Test for Spark

NOTE: Do not crank engine or perform tests with spark plug lead disconnected and not grounded, or permanent coil damage may occur.

1. With engine stopped, disconnect spark plug lead. Connect spark plug lead to post terminal of spark tester and attach tester clip to a good engine ground.
2. Crank engine over, establishing a minimum of 550-600 RPM, and observe tester for spark.

Condition	Possible Cause	Conclusion
Cylinder is not firing or has intermittent spark.	Wiring, Connections, or System Power	Using a DVOM, attach black (-) lead of meter to battery ground, remove primary plug from coil, test voltage at red wire with black tracer at coil primary connector with ignition key ON. Battery voltage should be seen. If no voltage, check all fuses. Key OFF, perform continuity test between black primary wire connector and corresponding pin terminal 1 on black ECU connector (refer to EFI System Wiring Diagram). If no continuity is found, repair or replace electrical wiring harness. If continuity is found, refer to EFI System, Ignition Coil Testing, test circuit (power and ground). Repair/replace as needed. Test ignition coil and connection. Refer to <b>Test Ignition System</b> (above).
Tester shows spark but engine misses or won't run.	Spark Plug	Try new spark plug.
	Flywheel Key	Remove flywheel, inspect key, replace key if damaged.
No spark.	Ignition Switch, EFI System, Kill Lead	Test for "Safety System Active" as described in step 1 of <b>Test Ignition System</b> (above). Inspect red 10 amp fuses. Replace fuse if found blown. If fuse is OK, using a DVOM, attach black (-) lead of meter to battery ground, key ON, test for voltage at 2 red 10 amp fuses. Battery voltage should be seen on both sides of fuses. If voltage is found on 1 side of fuse only, inspect for blown fuse or inspect fuse holder/ terminals for arching or corrosion. If no voltage is seen at any fuse, further electrical testing inspection is required (application, key switch, ground connections, etc.) Recheck position of ignition switch and check for shorted kill lead.
Good spark but engine runs poorly or existing plug condition is questionable.	Spark Plug	Install new spark plug and retest engine performance.
	Flywheel Key	Remove flywheel, inspect key, replace key if damaged.

### **Starter (OEM Supplied)**

Refer to operating instructions of equipment this engine powers for specific starter system instructions.

# Disassembly/Inspection and Service

	<b>⚠ WARNING</b>	Before working on engine or equipment, disable engine as follows: 1) Disconnect spark plug lead(s). 2) Disconnect negative (-) battery cable from battery.
	Accidental Starts can cause severe injury or death. Disconnect and ground spark plug lead(s) before servicing.	

## External Engine Components

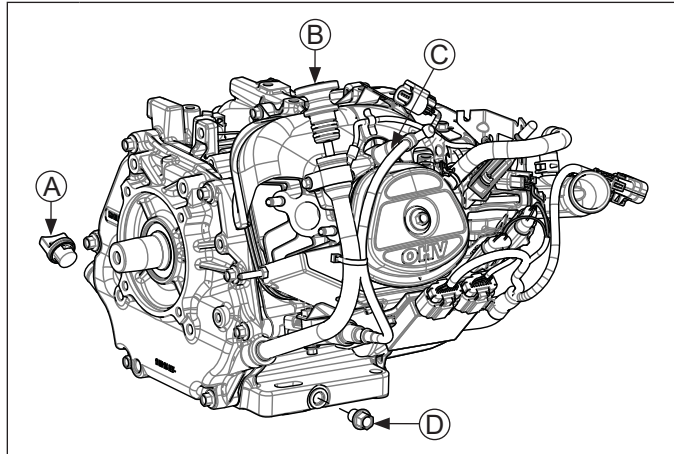

<b>A</b>	Oil Fill Plug	<b>B</b>	Dipstick
<b>C</b>	Spark Plug Lead	<b>D</b>	Oil Drain Plug

Clean all parts thoroughly as engine is disassembled. Only clean parts can be accurately inspected and gauged for wear or damage. There are many commercially available cleaners that will quickly remove grease, oil, and grime from engine parts. When such a cleaner is used, follow manufacturer's instructions and safety precautions carefully.

Make sure all traces of cleaner are removed before engine is reassembled and placed into operation. Even small amounts of these cleaners can quickly break down lubricating properties of engine oil.

**NOTE:** Engines in this application have air cleaner, starter generator, in-tank fuel pump, EFI fuel filter, and all fuel lines supplied and installed by OEM. Refer to equipment manufacturer's manual for information on these components and before working on fuel system. Use only original equipment replacement parts.

## Disconnect Spark Plug Lead

**NOTE:** Pull on boot only, to prevent damage to spark plug lead.

1. Disconnect lead from spark plug.
2. Turn off fuel at fuel supply.

## Drain Oil From Crankcase

1. Remove 1 oil drain plug and oil fill plug or dipstick.
2. Allow ample time for oil to drain from crankcase.

## Disconnect Oxygen Sensor

**NOTE:** Unless oxygen sensor is damaged or malfunctioning, disassembly from OEM supplied muffler is unnecessary.

Disconnect oxygen sensor connector from wire harness.

## Remove Air Inlet Elbow

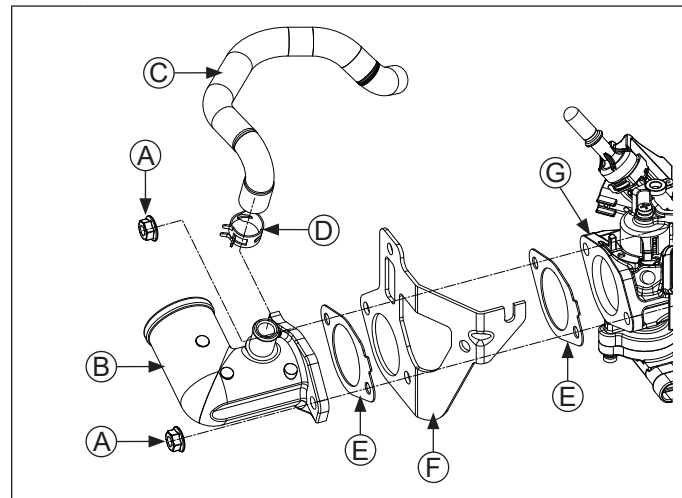

<b>A</b>	Nut	<b>B</b>	Air Inlet Elbow
<b>C</b>	Breather Hose with Sleeve	<b>D</b>	Clamp
<b>E</b>	Throttle Body Gasket	<b>F</b>	Governor Bracket
<b>G</b>	Throttle Body		

1. Remove nuts securing air inlet elbow.
2. Disconnect breather hose from valve cover.
3. Remove air inlet elbow and throttle body gasket from mounting studs.
4. Remove governor bracket and throttle body gasket from mounting studs.

## Remove Throttle Body Assembly

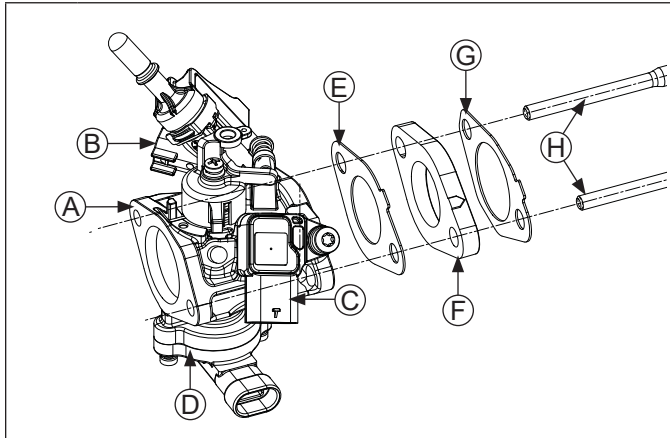

<b>A</b>	Throttle Body	<b>B</b>	Fuel Injector
<b>C</b>	TMAP	<b>D</b>	Throttle Position Sensor (TPS)
<b>E</b>	Insulator to Throttle Body Gasket	<b>F</b>	Insulator
<b>G</b>	Insulator to Cylinder Head Gasket	<b>H</b>	Intake Studs

1. With a screwdriver, slide locking tab on electrical connector of TMAP. Detach connector.
2. Disconnect fuel injector electrical connector.
3. Disconnect throttle position sensor (TPS) connector.
4. Slide throttle body off intake studs and remove insulator to throttle body gasket, insulator, and insulator to cylinder head gasket.

## Remove Fuel Injector and TMAP

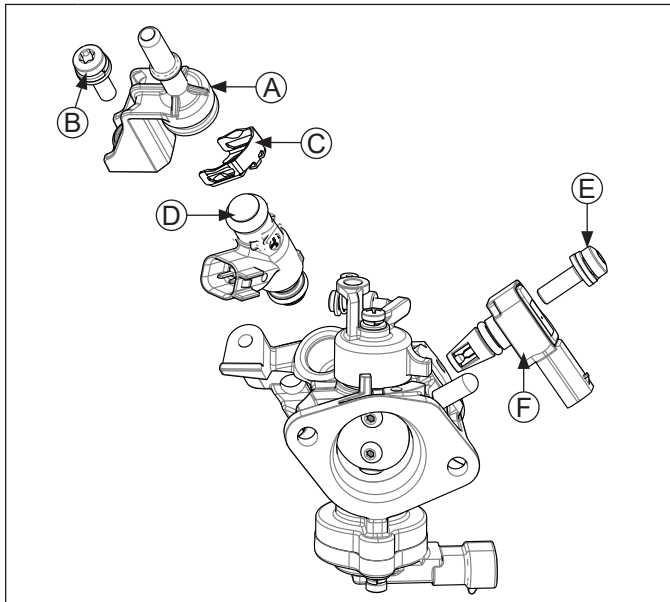

<b>A</b>	Fuel Injector Cap	<b>B</b>	Screw
<b>C</b>	Metal Retaining Clip	<b>D</b>	Fuel Injector
<b>E</b>	Screw	<b>F</b>	TMAP

## Remove Fuel Injector

NOTE: Unless fuel injector is damaged or malfunctioning, disassembly from throttle body is unnecessary.

NOTE: Make note of fuel injector position before removing.

NOTE: Unless fuel injector cap is damaged, removing retainer securing cap to injector is unnecessary.

1. Disconnect fuel injector electrical connector.
2. Remove screw and pull injector out of throttle body.
3. When removed, pull metal retaining clip connecting fuel injector to fuel injector cap/fuel cap bracket. There may be some fuel left in line. Any spilled fuel must be cleaned up immediately.

## Remove Temperature/Manifold Absolute Pressure (TMAP) Sensor

NOTE: Unless TMAP sensor is damaged or malfunctioning, disassembly from throttle body is unnecessary.

1. With a screwdriver, slide locking tab on electrical connector.
2. Detach connector.
3. Remove screw and pull TMAP sensor out of throttle body.

## Remove Upper Heat Shield and Engine Temperature Sensor

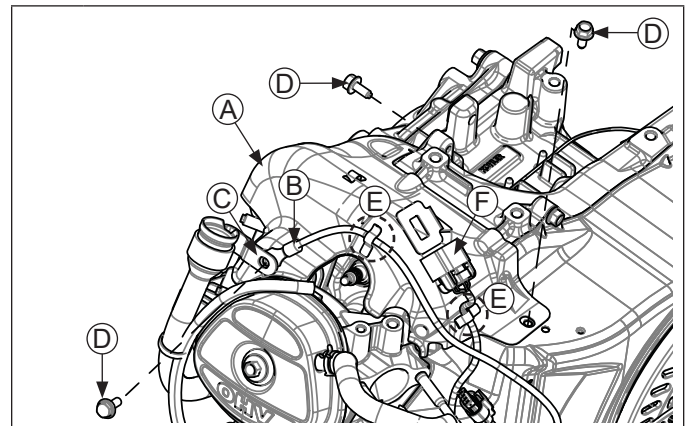

<b>A</b>	Upper Heat Shield	<b>B</b>	Engine Temperature Sensor
<b>C</b>	Dipstick Tube Bracket	<b>D</b>	Screw
<b>E</b>	Clip	<b>F</b>	Oxygen Sensor Connector

1. Note position of engine temperature sensor. Sensor is located between oil fill tube bracket and upper heat shield. Remove screw securing oil fill tube bracket and sensor to upper heat shield.
2. Remove engine temperature wire from upper heat shield clip. Remove oxygen sensor wire from upper heat shield clip.
3. Remove screws and lift off upper heat shield.

# Disassembly/Inspection and Service

## Fuses and ECU Components

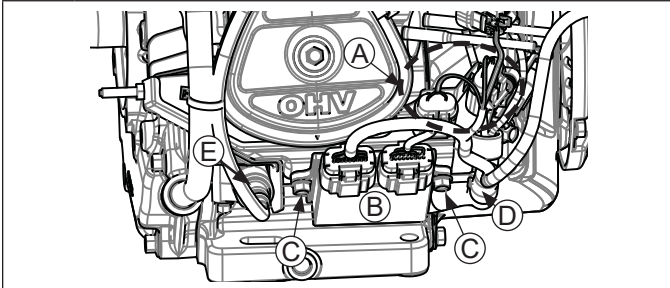

<b>A</b>	Fuses/Fuse Holders	<b>B</b>	ECU
<b>C</b>	Screw	<b>D</b>	Cable Clip
<b>E</b>	Ignition Coil		

### Remove Fuses

Remove fuses from holders located on lower shield.

### Remove Electronic Control Unit (ECU)

1. Remove screws and remove ECU and cable clip with wiring harness from lower shield.
2. Disconnect Black and Grey electrical connectors from ECU.

### Remove Cylinder Shield

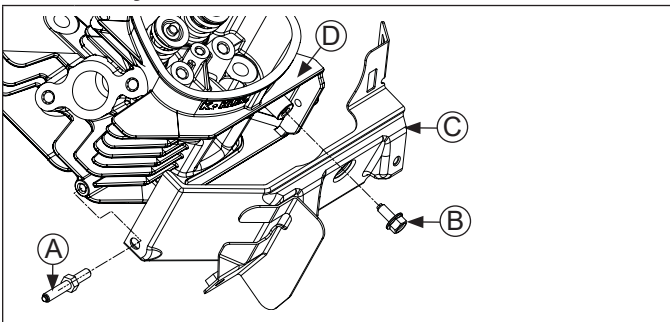

<b>A</b>	Ground Stud	<b>B</b>	Screw
<b>C</b>	Cylinder Shield	<b>D</b>	Cylinder Head

NOTE: Unless ignition coil is damaged or malfunctioning, disassembly from lower shield is unnecessary.

1. Disconnect ignition coil electrical connector.
2. Remove screw and ground stud securing lower shield to cylinder head; remove lower shield.

## Blower Housing Components

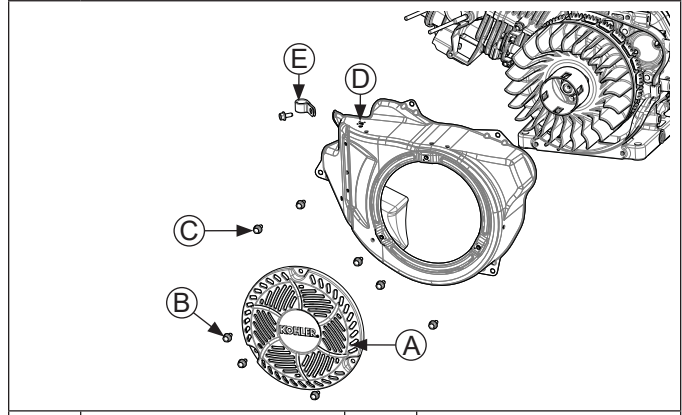

<b>A</b>	Blower Housing Screen	<b>B</b>	Screw
<b>C</b>	Screw	<b>D</b>	Blower Housing
<b>E</b>	Clamp		

### Remove Blower Housing Screen

NOTE: Unless blower housing screen is damaged, disassembly from blower housing is unnecessary.

Remove screws securing blower housing screen to blower housing and remove screen.

### Remove Blower Housing

1. A clamp secures part of wiring harness to blower housing. Note which wires are secured, remove screw and clamp from blower housing.
2. Remove screws securing blower housing to engine and remove blower housing.

## Flywheel Components

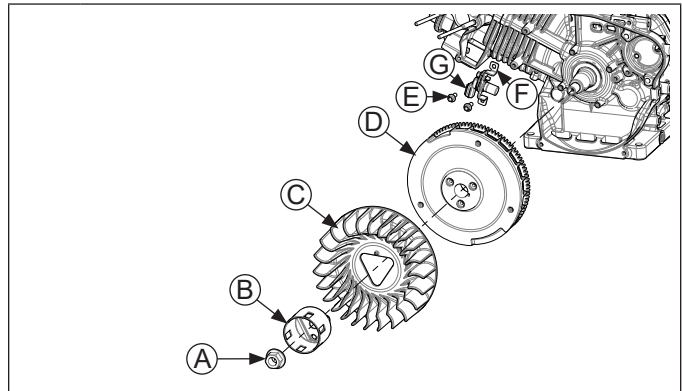

<b>A</b>	Flywheel Retaining Nut	<b>B</b>	Drive Cup
<b>C</b>	Flywheel Fan	<b>D</b>	Flywheel
<b>E</b>	Crankshaft Position Sensor Bracket Screw	<b>F</b>	Crankshaft Position Sensor Bracket
<b>G</b>	Crankshaft Position Sensor		

## Remove Crankshaft Position Sensor

NOTE: Do not remove sensor from bracket unless sensor is being replaced.

1. Unplug crankshaft position sensor electrical connector.
2. Remove upper screw securing crankshaft position sensor bracket to crankcase post.
3. Remove lower screw securing crankshaft position sensor bracket to crankcase post and also securing ground wire.
4. Remove crankshaft position sensor assembly.

## Remove Flywheel

NOTE: Whenever possible, an impact wrench should be used to loosen flywheel retaining nut. A flywheel strap wrench may be used to hold flywheel when loosening or tightening flywheel retaining nut.

NOTE: Always use a puller to remove flywheel from crankshaft. Do not strike flywheel or crankshaft as these parts could become cracked or damaged.

1. Remove flywheel retaining nut.
2. Remove drive cup and fan from flywheel.
3. Remove flywheel from crankshaft using a suitable puller.
4. Remove flywheel key from crankshaft keyway.

## Inspection

Inspect flywheel for cracks and flywheel keyway for damage. Replace flywheel if it is cracked. Replace flywheel, crankshaft, and key if flywheel key is sheared or keyway is damaged.

## Remove Wiring Harness

Disconnect oil level switch green wire from wiring harness; pull wiring harness through clip secured to crankcase. Pick up wiring harness from on top of crankcase, thread through hole and remove.

## Remove Valve Cover

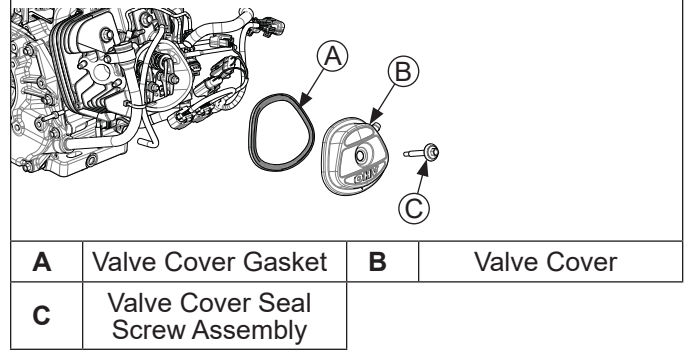

Remove valve cover seal screw assembly and remove valve cover and gasket from engine. Breather assembly is inside valve cover.

## Breather System

Breather system is designed to control amount of oil in head area and still maintain necessary vacuum in crankcase.

When piston moves downward, crankcase gases are pushed past reed through mesh filter into intake system. Upward travel of piston closes reed and creates a low vacuum in lower crankcase. Any oil separated out through filter drains back into crankcase.



# Disassembly/Inspection and Service

## Cylinder Head Components

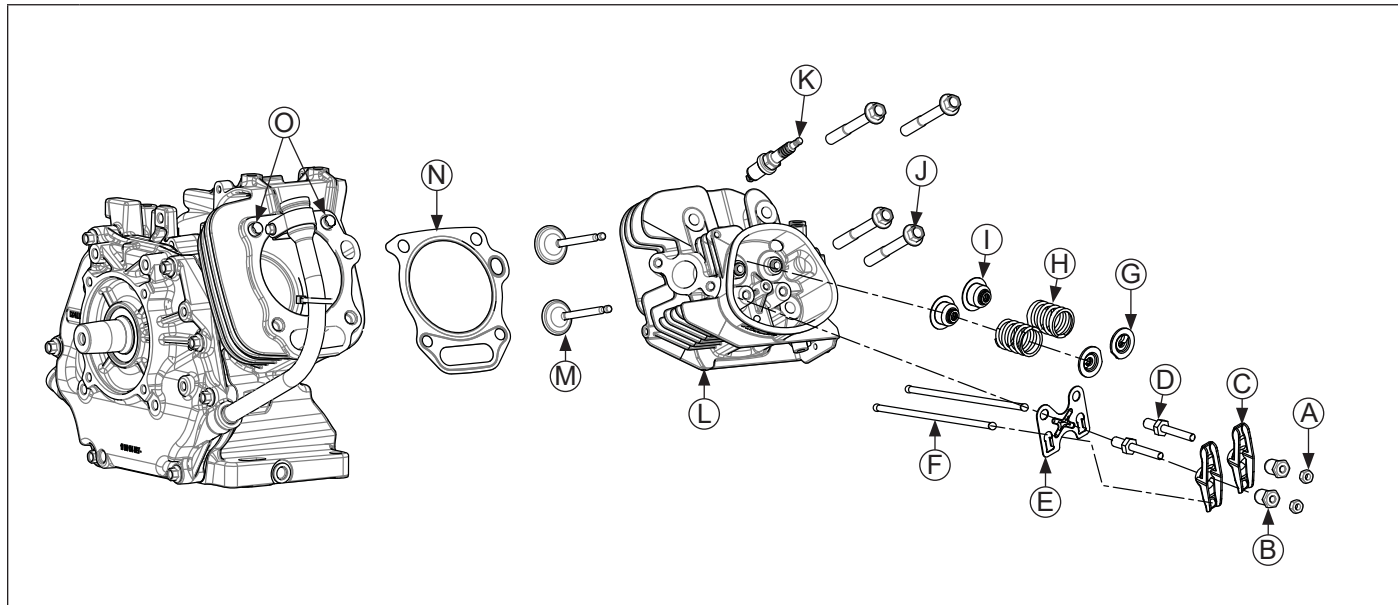

<b>A</b>	Hex Jam Nut	<b>B</b>	Rocker Arm Pivot Adjuster	<b>C</b>	Rocker Arm	<b>D</b>	Rocker Arm Stud
<b>E</b>	Push Rod Guide	<b>F</b>	Push Rod	<b>G</b>	Valve Spring Retainer	<b>H</b>	Valve Spring
<b>I</b>	Valve Stem Seal	<b>J</b>	Cylinder Head Screw	<b>K</b>	Spark Plug	<b>L</b>	Cylinder Head
<b>M</b>	Valve	<b>N</b>	Cylinder Head Gasket	<b>O</b>	Dowel Pin		

### Remove Rocker Arms, Push Rods, and Cylinder Head Assembly

NOTE: Mark location of push rods and any other part removed being reused.

1. Loosen and remove rocker arm pivot adjuster and hex jam nuts. Remove rocker arms and push rods.
2. Remove spark plug.
3. Remove screws securing cylinder head.
4. Remove cylinder head, dowel pins, and cylinder head gasket.

### Remove Valves

NOTE: Mark locations of any part removed being reused.

1. Supporting head of valve from below, depress valve spring retainer and valve spring until retainer can be released from valve stem. Remove valve spring and valve from head. Repeat this procedure for remaining valve.
2. Remove and replace valve stem seals whenever cylinder head is serviced or disassembled.

### Inspection and Service

After cleaning, check flatness of cylinder head and corresponding top surface of crankcase, using a surface plate or precision straight edge and feeler gauge. Maximum allowable out of flatness is 0.1 mm (0.0039 in.).

Carefully inspect valve mechanism parts. Inspect valve springs and related hardware for excessive wear or distortion. Check valves and valve seat area or inserts for evidence of deep pitting, cracks, or distortion.

Check clearance of valve stems in guides. See valve details and specifications.

Hard starting, or loss of power accompanied by high fuel consumption may be symptoms of faulty valves. Although these symptoms could also be attributed to worn rings, remove and check valves first. After removal, clean valve heads, faces, and stems with a power wire brush.

Then, carefully inspect each valve for defects such as warped head, excessive corrosion, or worn stem end. Replace valves found to be in bad condition.

## Valve Guides

If a valve guide is worn beyond specifications, it will not guide valve in a straight line. This may result in burnt valve faces or seats, loss of compression, and excessive oil consumption.

To check valve guide-to-valve stem clearance, thoroughly clean valve guide and, using a split-ball gauge, measure inside diameter of guide. Then, using an outside micrometer, measure diameter of valve stem at several points on stem where it moves in valve guide. Use largest stem diameter to calculate clearance by subtracting stem diameter from guide diameter. If intake or exhaust clearance exceeds specifications in Valve Specification table, determine whether valve stem or guide is responsible for excessive clearance.

If guides are within limits but valve stems are worn beyond limits, install new valves.

## Valve Seat Inserts

Hardened steel alloy intake and exhaust valve seat inserts are press-fitted into cylinder head. Inserts are not replaceable but can be reconditioned if not too badly pitted or distorted. If cracked or badly warped, cylinder head should be replaced.

Recondition valve seat inserts following instructions provided with valve seat cutter being used. Final cut should be made with a 44.5° cutter as specified for valve seat angle. Cutting proper 45° valve face angle, as specified, and proper valve seat angle (44.5°) will achieve desired 0.5° (1.0° full cut) interference angle where maximum pressure occurs on outside diameters of valve face and seat.

## Lapping Valves

Reground or new valves must be lapped in, to provide proper fit. Use a hand valve lapping tool with suction cup for final lapping. Lightly coat valve face with fine grade of grinding compound, then rotate valve on seat with tool. Continue lapping until smooth surface is obtained on seat and on valve face. Thoroughly clean cylinder head in soap and hot water to remove all traces of grinding compound. After drying cylinder head, apply a light coating of SAE 10 oil to prevent rusting.

## Valve Stem Seals

These engines use valve stem seals on intake and exhaust valves.

Always use new seals when valves are removed from cylinder head. Seals should also be replaced if deteriorated or damaged in any way. Never reuse old seals.

## Valve Details

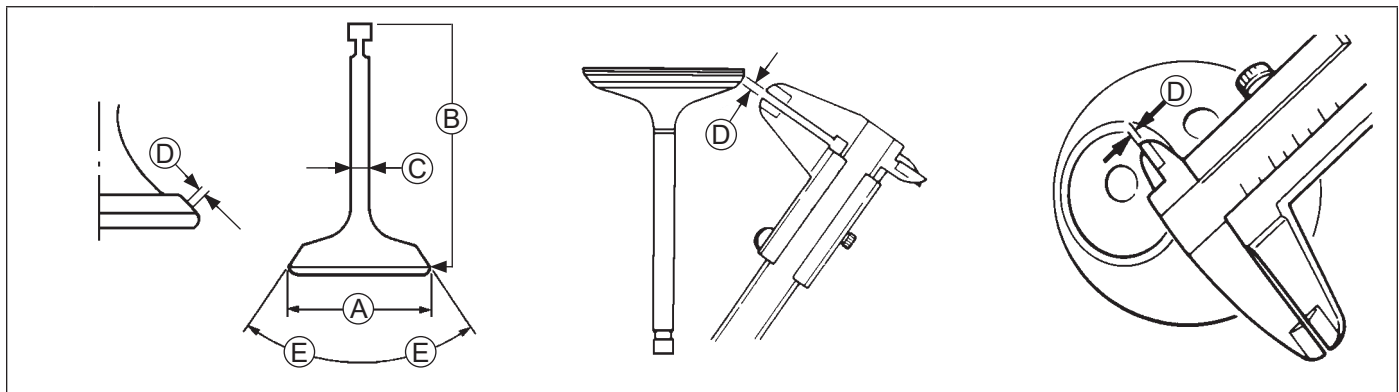

Valve Specifications

Item	Dimension	Intake	Exhaust
A	Head Diameter	35.875-36.125 mm (1.4124-1.4222 in.)	32.875-33.125 mm (1.2943-1.3041 in.)
B	Valve Length	86.175-86.375 mm (3.3927-3.4006 in.)	86.341-86.541 mm (3.3993-3.4071 in.)
C	Stem Diameter	6.560-6.575 mm (0.2583-0.2589 in.)	6.545-6.560 mm (0.2577-0.2583 in.)
D	Face/Seat Width - Maximum	1.5 mm (0.059 in.)	1.5 mm (0.059 in.)
E	Face/Seat Angle	45°-44.5°	45°-44.5°

# Disassembly/Inspection and Service

## Crankcase/Crankshaft/Camshaft/Closure Plate Components

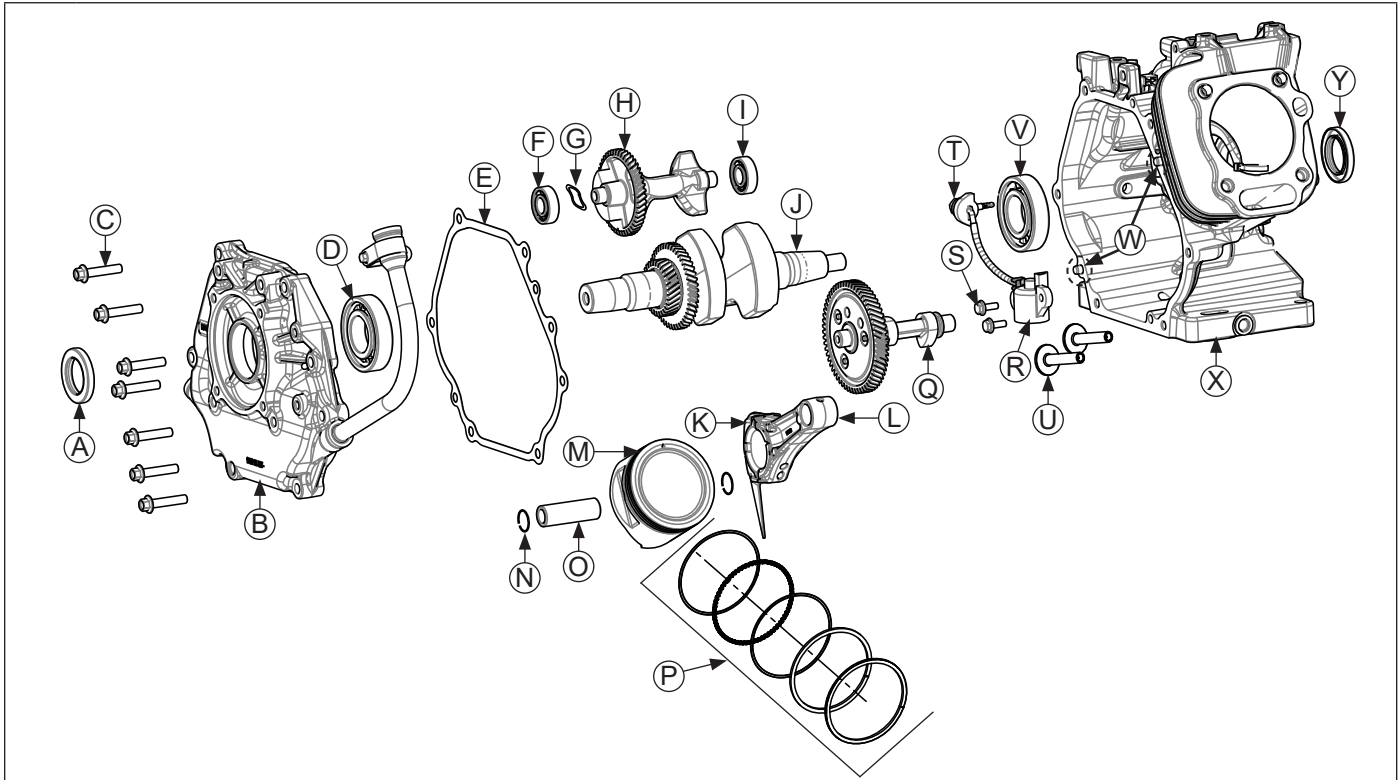

<b>A</b>	Closure Plate Oil Seal	<b>B</b>	Closure Plate	<b>C</b>	Screw	<b>D</b>	Closure Plate Bearing
<b>E</b>	Closure Plate Gasket	<b>F</b>	Closure Plate Balance Shaft Bearing	<b>G</b>	Wave Spring	<b>H</b>	Balance Shaft
<b>I</b>	Crankcase Balance Shaft Bearing	<b>J</b>	Crankshaft	<b>K</b>	Connector Rod End Cap	<b>L</b>	Connector Rod
<b>M</b>	Piston	<b>N</b>	Piston Pin Retainer	<b>O</b>	Piston Pin	<b>P</b>	Piston Ring Set
<b>Q</b>	Camshaft	<b>R</b>	Oil Sentry™ Level Switch	<b>S</b>	Screw	<b>T</b>	Oil Sentry™ Wire
<b>U</b>	Tappet	<b>V</b>	Crankcase Bearing	<b>W</b>	Dowel Pin	<b>X</b>	Crankcase
<b>Y</b>	Crankcase Oil Seal						

## Remove Oil Fill Tube

### Details

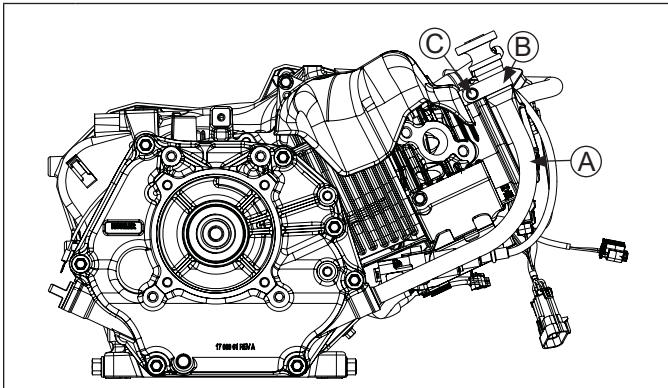

<b>A</b>	Oil Fill Tube	<b>B</b>	Oil Fill Tube Bracket
<b>C</b>	Bracket Screw		

NOTE: Unless oil fill tube is damaged, disassembly from closure plate is unnecessary.

1. Remove bracket screw and oil fill tube bracket.
2. If necessary, remove tube from closure plate. If not, allow oil fill tube to remain in closure plate. Tube will be removed with closure plate as an assembly.

## Remove Closure Plate

NOTE: Do not pry on gasket surface of crankcase or closure plate, as this can cause damage and leakage.

1. Remove screws securing closure plate to crankcase.
2. Remove closure plate, gasket, and dowel pins (if required) from crankcase.
3. Remove closure plate and oil fill tube as an assembly.
4. Remove shims from crankshaft.

## Inspection

Inspect main bearing surface for wear or damage (refer to Specifications). Replace closure plate if required.

## Remove Balance Shaft

Remove balance shaft (with wave spring) by pulling it straight out of crankcase.

## Remove Camshaft and Valve Tappets

1. Remove camshaft by pulling it straight out of crankcase.
2. Remove valve tappets by pulling them straight out of crankcase. Mark their positions.

## Automatic Compression Release (ACR)

### ACR Operation Details

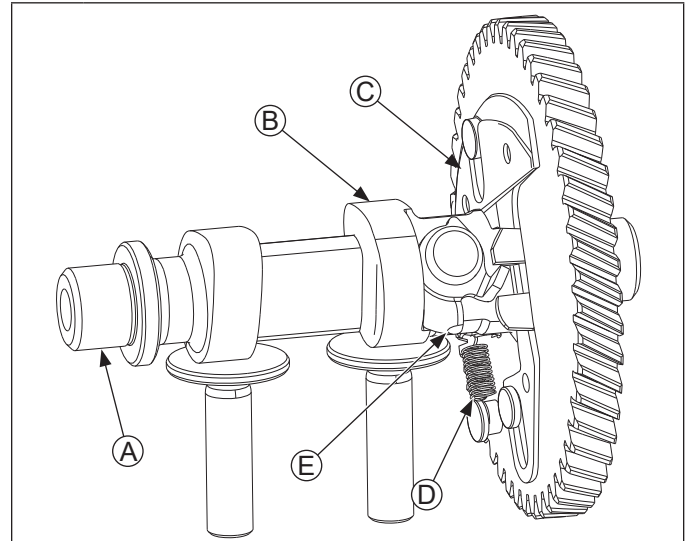

<b>A</b>	Camshaft	<b>B</b>	Exhaust Cam Lobe
<b>C</b>	Decompression Weight	<b>D</b>	Return Spring
<b>E</b>	Arm		

ACR mechanism consists of a spring-loaded arm and sliding pin mounted to camshaft. When engine is rotating at low cranking speeds, arm holds pin so it protrudes above heel of exhaust cam. This holds exhaust valve off of its seat during first part of compression stroke.

After engine speed increases centrifugal force causes spring-loaded arm to move outward causing pin to retract. When in this position pin has no effect on exhaust valve and engine operates at full compression and power.

## Benefits

As a result of reduced compression at cranking speeds, several important benefits are obtained:

1. Electric start models can use a smaller starter and battery more practical for application.
2. ACR eliminates need for a spark retard/advance mechanism. ACR eliminates this kickback making manual starting safer.
3. Engines with ACR start much faster in cold weather than engines without ACR.
4. Engines with ACR can be started with worn or fouled spark plug. Engines without ACR are more difficult to start with those same spark plug.

# Disassembly/Inspection and Service

## Inspection and Service

### Dimension A

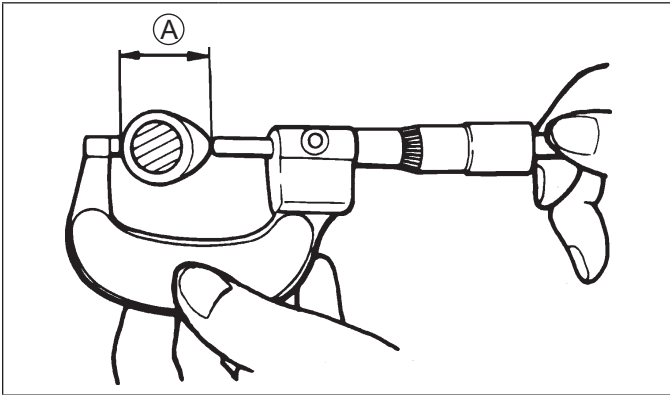

Cam Lobe		
INTAKE	32.286 mm (1.271 in.)	32.032 mm (1.261 in.)
EXHAUST	32.506 mm (1.280 in.)	32.252 mm (1.270 in.)

### Dimension B

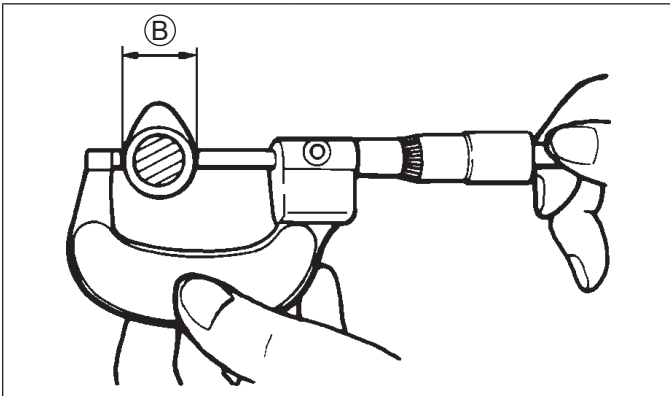

Cam Lobe Specifications		
Valve	Dimension B	Service Limit
INTAKE	25.94 mm (1.021 in.)	25.68 mm (1.011 in.)
EXHAUST	25.94 mm (1.021 in.)	25.68 mm (1.011 in.)

### Dimension C

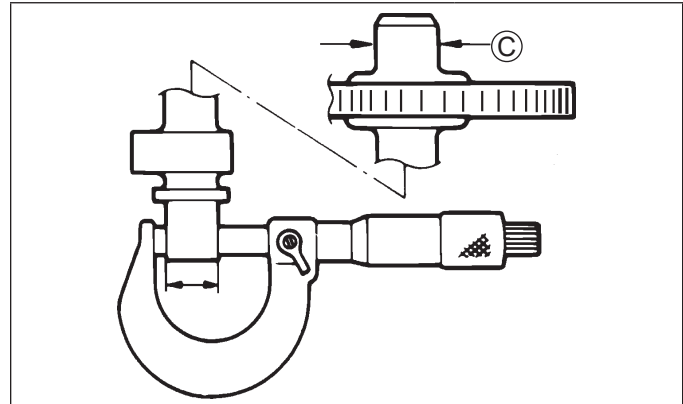

Camshaft Journal Specifications	
Dimension C	Limit
15.975 mm (0.6289 in.)	15.900 mm (0.6260 in.)

Inspect gear teeth of camshaft. If teeth are badly worn, chipped, or some are missing, replacement of camshaft will be necessary. If unusual wear or damage is evident on either lobe or mating tappet, camshaft and both tappets must be replaced. Check condition and operation of ACR mechanism.

Measure cam lobe profile, A and B, using an outside micrometer and compare with specifications listed.

Measure camshaft journals, C, which fit in ball bearings, for wear using a micrometer. Compare with specifications listed.

### Remove Piston, Connecting Rod and Crankshaft

NOTE: If a carbon ridge is present at top of cylinder bore, use a ridge reamer to remove it before attempting to remove piston.

1. Remove screws securing end cap to connecting rod. Remove end cap. Carefully guiding connecting rod, slide piston and connecting rod from cylinder bore.
2. Remove crankshaft from crankcase.

### Connecting Rod Inspection and Service

Check bearing area (big end) for excessive wear, score marks, running and side clearances (see Specifications and Tolerances). Replace rod and cap if scored or excessively worn.

Service replacement connecting rods are available in STD size and 0.25 mm (0.010 in.) undersize. 0.25 mm (0.010 in.) undersized rods have an identification marking on lower end of rod shank. Always refer to appropriate parts information to ensure correct replacements are used.

## Piston and Rings Inspection

Scuffing and scoring of piston and cylinder wall occurs when internal engine temperatures approach welding point of piston. Temperatures high enough to do this are created by friction, which is usually attributed to improper lubrication and/or overheating of engine.

Normally, very little wear takes place in piston boss-piston pin area. If original piston and connecting rod can be reused after new rings are installed, original pin can also be reused but new piston pin retainers are required. Piston pin is included as part of piston assembly – if pin boss in piston or pin are worn or damaged, a new piston assembly is required.

Ring failure is usually indicated by excessive oil consumption and blue exhaust smoke. When rings fail, oil is allowed to enter combustion chamber where it is burned along with fuel. High oil consumption can also occur when piston ring end gap is incorrect because ring cannot properly conform to cylinder wall under this condition. Oil control is also lost when ring gaps are not staggered during installation.

When cylinder temperatures get too high, lacquer and varnish collect on pistons causing rings to stick, which results in rapid wear. A worn ring usually takes on a shiny or bright appearance.

Scratches on rings and piston are caused by abrasive material such as carbon, dirt, or pieces of hard metal. Detonation damage occurs when a portion of fuel charge ignites spontaneously from heat and pressure shortly after ignition. This creates 2 flame fronts, which meet and explode to create extreme hammering pressures on a specific area of piston. Detonation generally occurs from using low octane fuels.

Preignition, or ignition of fuel charge before timed spark can cause damage similar to detonation. Preignition damage is often more severe than detonation damage. Preignition is caused by a hot spot in combustion chamber such as glowing carbon deposits, blocked cooling fins, an improperly seated valve, or wrong spark plug.

Replacement pistons are available in STD bore size, and 0.25 mm (0.010 in.) oversize. Replacement pistons include new piston ring sets and new piston pins.

Replacement ring sets are also available separately for STD, and 0.25 mm (0.010 in.) oversize pistons. Always use new piston rings when installing pistons. Never use old rings.

Some important points to remember when servicing piston rings:

1. Cylinder bore must be deglazed before service ring sets are used.
2. If cylinder bore does not need reboring and if old piston is within wear limits and free of score or scuff marks, old piston may be reused.
3. Remove old rings and clean up grooves. Never reuse old rings.
4. Before installing new rings on piston, place top 2 rings, each in turn, in its running area in cylinder bore and check end gap. Refer to Specifications.
5. After installing new compression (top and middle) rings on piston, check piston-to-ring side clearance. Refer to Specifications. If side clearance is greater than specified, a new piston must be used.

## Piston and Rings

### Inspection

#### Piston and Rings Components and Details

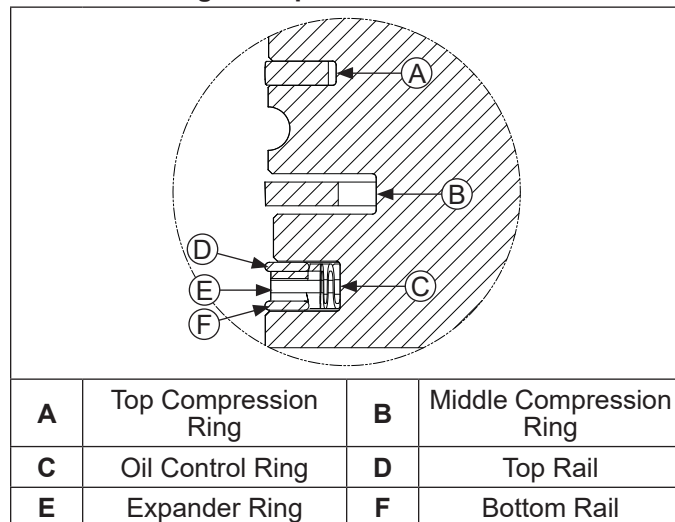

### Install New Piston Rings

#### Piston Ring Orientation

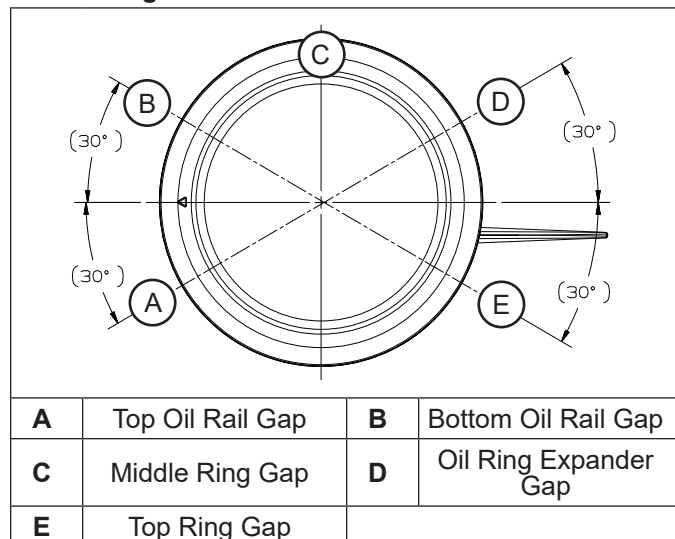

## Disassembly/Inspection and Service

NOTE: Rings must be installed correctly. Use a piston ring expander to install rings. Install bottom (oil control) ring first and top compression ring last.

To install new piston rings, proceed as follows:

1. Oil control ring (bottom groove): Install expander and then rails. Make sure ends of expander are not overlapped.
2. Middle compression ring (center groove): Install center ring using a piston ring installation tool. Make sure identification mark is up or colored dye stripe (if contained), is to left of end gap.
3. Top compression ring (top groove): Install top ring using a piston ring expander. Make sure identification mark is up or colored dye stripe (if contained), is to left of end gap.

### Crankshaft Inspection and Service

Inspect gear teeth of crankshaft. If teeth are badly worn, chipped, or some are missing, replacement of crankshaft will be necessary.

Inspect crankshaft bearing surfaces for scoring, grooving, etc. Measure running clearance between crankshaft journals and their respective bearing bores. Use an inside micrometer or telescoping gauge to measure inside diameter of both bearing bores in vertical and horizontal planes. Use an outside micrometer to measure outside diameter of crankshaft main bearing journals. Subtract journal diameters from their respective bore diameters to get running clearances. Check results against values in Specifications and Tolerances. If running clearances are within specification, and there is no evidence of scoring, grooving, etc., no further reconditioning is necessary. If bearing surfaces are worn or damaged, crankcase and/or closure plate will need to be replaced.

Inspect crankshaft keyways. If worn or chipped, replacement of crankshaft will be necessary. Inspect crankpin for score marks or metallic pickup. Slight score marks can be cleaned with crocus cloth soaked in oil. If wear limits are exceeded, as stated in Specifications, it will be necessary to replace crankshaft.

### Remove Oil Sentry™ System

1. Remove nut securing Oil Sentry™ lead wire grommet assembly in crankcase.
2. Pull grommet assembly from inside of crankcase.
3. Remove screws securing Oil Sentry™ level switch to crankcase. Remove switch assembly.

### Remove Crankcase and Closure Plate Seals and Bearings

NOTE: Inspect bearings for signs of wear by rotating inner race and examine for marring or cracks. Check to make sure race moves easily and is not sloppy. If bearing is tight and rotates smoothly, removal is not necessary. If you feel any roughness or chattering or bearing is sloppy, it should be replaced.

1. Remove oil seal from crankcase.
2. Using a suitable press, push crankshaft bearing from crankcase.

3. Remove oil seal from closure plate.
4. Using a suitable press, push crankshaft bearing from closure plate.

### Crankcase Inspection and Service

#### Cylinder Bore Detail

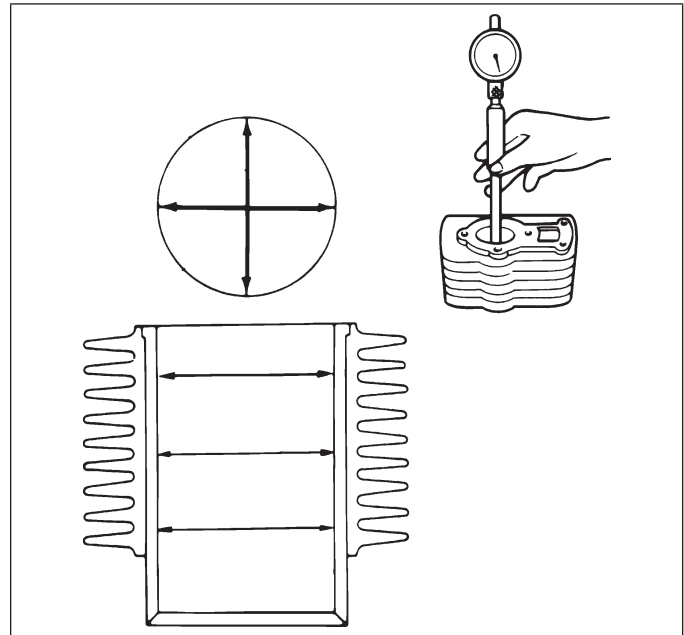

NOTE: A 0.25 mm (0.010 in.) oversize piston is available if resizing is selected. Initially, resize using a boring bar, then follow procedures for honing cylinder.

Check all gasket surfaces to make sure they are free of gasket fragments. Gasket surfaces must also be free of deep scratches or nicks.

Check cylinder bore for scoring. In severe cases, unburned fuel can cause scuffing and scoring of cylinder wall. It washes necessary lubricating oils off piston and cylinder wall. As raw fuel seeps down cylinder wall, piston rings make metal to metal contact with wall. Scoring of cylinder wall can also be caused by localized hot spots resulting from blocked cooling fins or from inadequate or contaminated lubrication.

If cylinder bore is badly scored, excessively worn, tapered, or out-of-round, resizing is necessary. Use an inside micrometer to determine amount of wear (refer to Specifications).

## Honing

### Crosshatch Detail

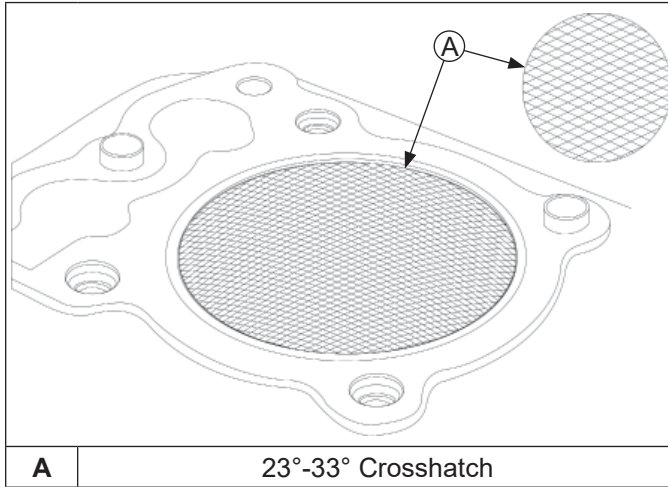

**NOTE:** Kohler pistons are custom-machined to exacting tolerances. When over-sizing a cylinder, it should be machined exactly 0.25 mm (0.010 in.) over new diameter (Specifications and Tolerances). Oversize Kohler replacement piston will then fit correctly.

While most commercially available cylinder hones can be used with either portable drills or drill presses, use of a low speed drill press is preferred as it facilitates more accurate alignment of bore in relation to crankshaft crossbore. Honing is best accomplished at a drill speed of about 250 RPM and 60 strokes per minute. After installing coarse stones in hone, proceed as follows:

1. Lower hone into bore and after centering, adjust stones so they are in contact with cylinder wall. Use of a commercial cutting-cooling agent is recommended.
2. With lower edge of each stone positioned even with lowest edge of bore, start drill and honing process. Move hone up and down while resizing to prevent formation of cutting ridges. Check size frequently.
3. When bore is within 0.064 mm (0.0025 in.) of desired size, remove coarse stones and replace them with burnishing stones. Continue with burnishing stones until bore is within 0.013 mm (0.0005 in.) of desired size and then use finish stones (220-280 grit) and polish bore to its final size. A crosshatch should be observed if honing is done correctly. Crosshatch should intersect at approximately 23°-33° off horizontal. Too flat an angle could cause rings to skip and wear excessively, and too steep an angle will result in high oil consumption.
4. After resizing, check bore for roundness, taper, and size. Use an inside micrometer, telescoping gauge, or bore gauge to take measurements. These measurements should be taken at 3 locations in cylinder – at top, middle, and bottom. Two measurements should be taken (perpendicular to each other) at each location.

## Clean Cylinder Bore After Honing

Proper cleaning of cylinder walls following boring and/or honing is very critical to a successful overhaul. Machining grit left in cylinder bore can destroy an engine in less than one hour of operation after a rebuild.

Final cleaning operation should always be a thorough scrubbing with a brush and hot, soapy water. Use a strong detergent capable of breaking down machining oil while maintaining a good level of suds. If suds break down during cleaning, discard dirty water and start again with more hot water and detergent. After scrubbing, rinse cylinder with very hot, clear water, dry it completely, and apply a light coating of engine oil to prevent rusting.

## Measuring Piston-to-Bore Clearance

### Piston Details

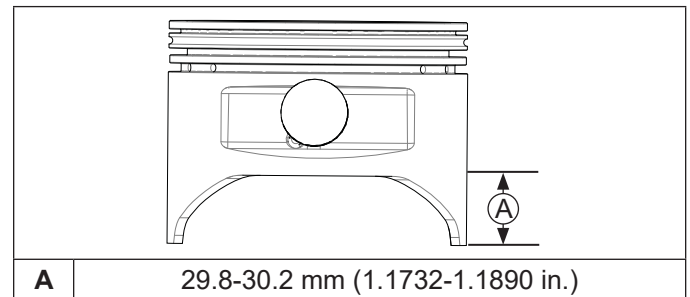

**NOTE:** Do not use a feeler gauge to measure piston-to-bore clearance, it will yield inaccurate measurements. Always use a micrometer.

Before installing piston into cylinder bore, it is necessary that clearance be accurately checked. This step is often overlooked, and if clearances are not within specifications, engine failure will usually result.

Use following procedure to accurately measure piston-to-bore clearance:

1. Use a micrometer and measure diameter of piston above bottom of piston skirt and perpendicular to piston pin.
2. Use an inside micrometer, telescoping gauge, or bore gauge and measure cylinder bore. Take measurement approximately 7.0 mm (0.2760 in.) below top of bore and perpendicular to piston pin.
3. Piston-to-bore clearance is difference between bore diameter and piston diameter (step 2 minus step 1).



# Reassembly

## Crankcase/Crankshaft/Camshaft/Closure Plate Components

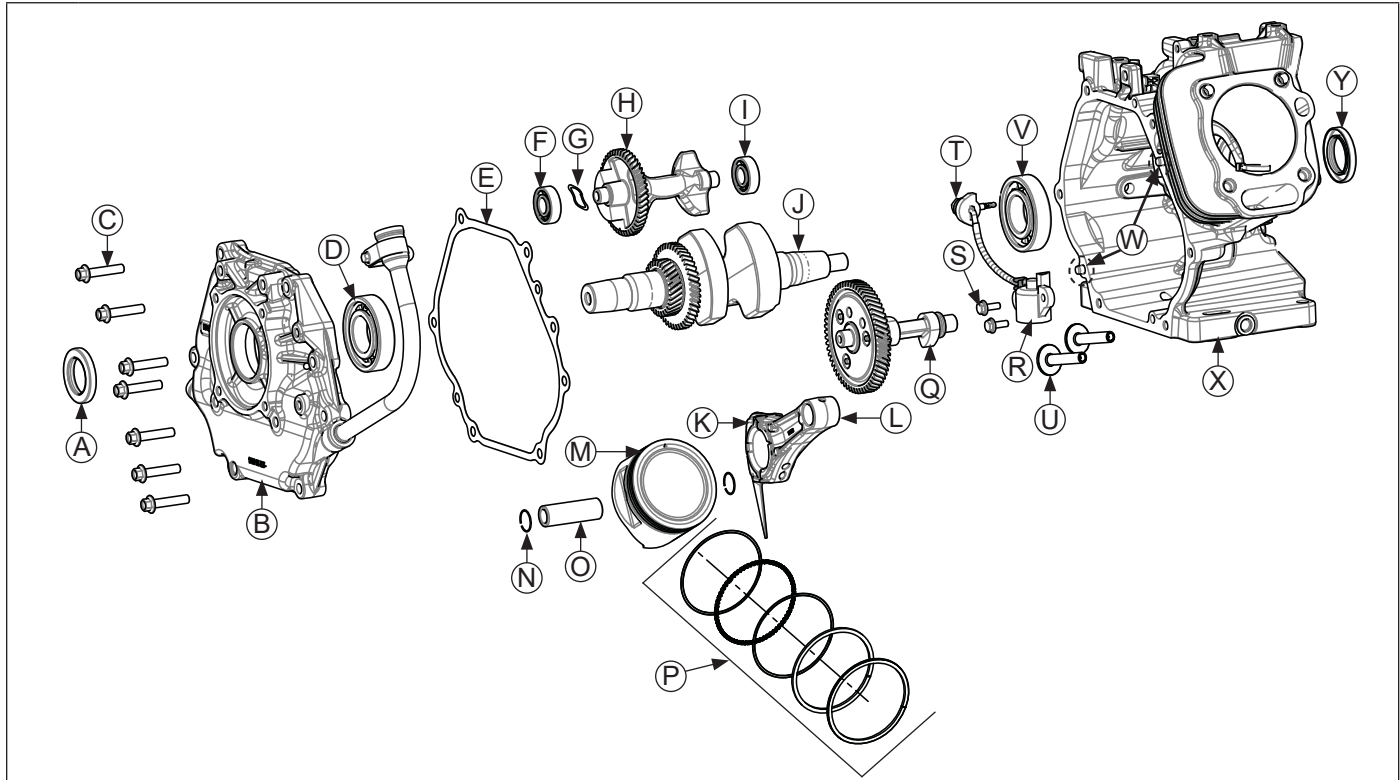

<b>A</b>	Closure Plate Oil Seal	<b>B</b>	Closure Plate	<b>C</b>	Screw	<b>D</b>	Closure Plate Bearing
<b>E</b>	Closure Plate Gasket	<b>F</b>	Closure Plate Balance Shaft Bearing	<b>G</b>	Wave Spring	<b>H</b>	Balance Shaft
<b>I</b>	Crankcase Balance Shaft Bearing	<b>J</b>	Crankshaft	<b>K</b>	Connector Rod End Cap	<b>L</b>	Connector Rod
<b>M</b>	Piston	<b>N</b>	Piston Pin Retainer	<b>O</b>	Piston Pin	<b>P</b>	Piston Ring Set
<b>Q</b>	Camshaft	<b>R</b>	Oil Sentry™ Level Switch	<b>S</b>	Screw	<b>T</b>	Oil Sentry™ Wire
<b>U</b>	Tappet	<b>V</b>	Crankcase Bearing	<b>W</b>	Dowel Pin	<b>X</b>	Crankcase
<b>Y</b>	Crankcase Oil Seal						

NOTE: Engines in this application have air cleaner, starter generator, in-tank fuel pump, EFI fuel filter, and all fuel lines supplied and installed by OEM. Refer to equipment manufacturer's manual for information on these components and before working on fuel system. Use only original equipment replacement parts.

NOTE: Make sure engine is assembled using all specified torque values, tightening sequences, and clearances. Failure to observe specifications could cause severe engine wear or damage. Always use new gaskets.

## Install Crankcase Bearings and Oil Seals

### Details

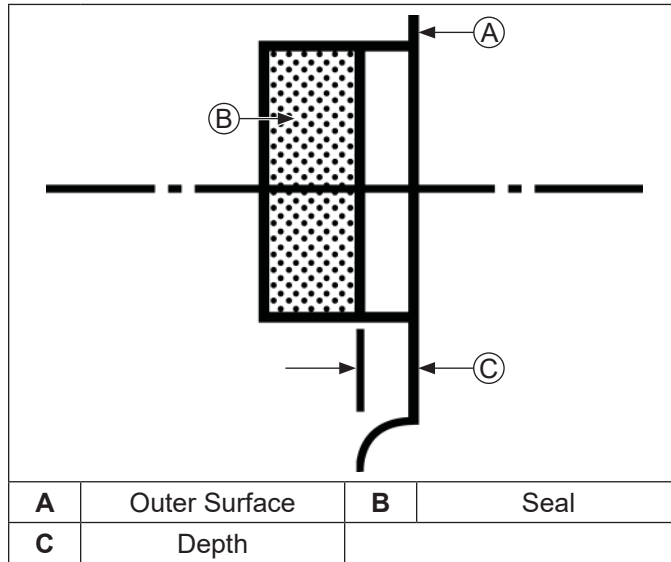

NOTE: Oil bearings liberally with engine oil when installing.

NOTE: In steps 3 and 4, position oil seals with manufacturer's identification marks visible and facing you.

1. Make sure there are no nicks, burrs, or damage in bores for bearings. Crankcase and closure plate must be clean.
2. Use an arbor press to make sure bearings are installed straight into their respective bores, until fully seated.
3. Using an appropriate seal driver, install oil seal into closure plate to depth of 8.2 mm (0.323 in.) from outer surface.
4. Using an appropriate seal driver, install oil seal into crankcase to depth of 0.0-1.0 mm (0.0-0.039 in.) from outer surface.
5. Apply a light coating of lithium grease to seal lips after installing.

### Install Oil Sentry™ System

1. Mount Oil Sentry™ switch into crankcase housing using two M6x18 screws and torque to 8 N·m (71 in. lb.).
2. Route wire lead grommet assembly through crankshaft housing.
3. Install nut on grommet assembly external stud and torque to 10 N·m (89 in. lb.).

## Install Crankshaft

Carefully slide flywheel end of crankshaft through main ball bearing and seal.

## Install Connecting Rod with Piston and Rings

### Connecting Rod Details

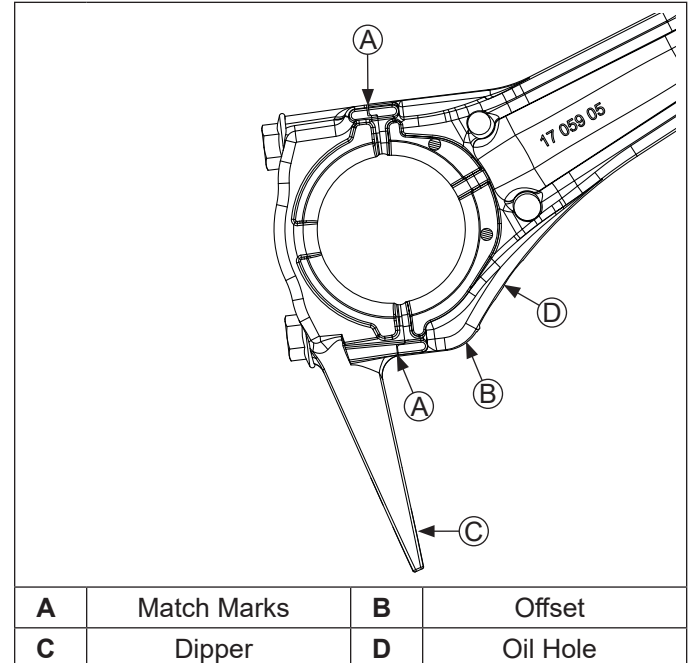

1. Make sure these are correct before installing.
  - a. Locating mark on piston is down.
  - b. Connecting rod offset is down and oil hole is in 4 o'clock position shown. Match marks should align as shown with dipper down.
2. If piston rings were removed, see Disassembly/ Inspection and Service procedure to install rings.
3. Lubricate cylinder bore, piston, piston pin, and piston rings with engine oil. Compress rings using a piston ring compressor.
4. Lubricate crankshaft journal and connecting rod bearing surfaces with engine oil.
5. Ensure ▼ stamping on piston is facing down toward base of engine. Use a hammer handle or rounded wood dowel and gently tap piston into cylinder. Be careful oil ring rails do not spring free between bottom of ring compressor and top of cylinder.
6. Install connecting rod cap to connecting rod so dipper is down and match marks are aligned.
7. Torque both screws in increments to 20 N·m (177 in. lb.).

# Reassembly

## Install Balance Shaft

### Timing Mark Detail

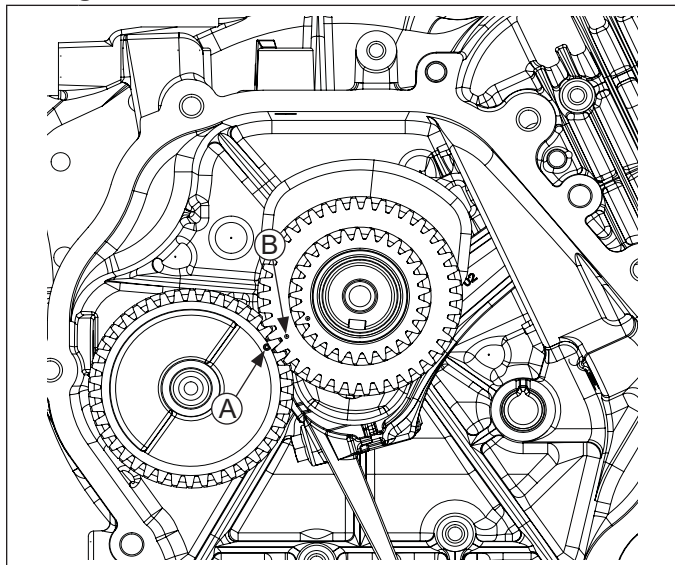

<b>A</b>	Balance Shaft Timing Mark	<b>B</b>	Balance Shaft Drive Gear on Crankshaft Timing Mark
----------	---------------------------	----------	--

1. Position crankshaft so timing mark on larger crankgear is in 8 o'clock position.
2. Install balance shaft (with wave spring), aligning timing mark with timing mark on larger crankgear.

## Install Valve Tappets and Camshaft

### Timing Mark Detail

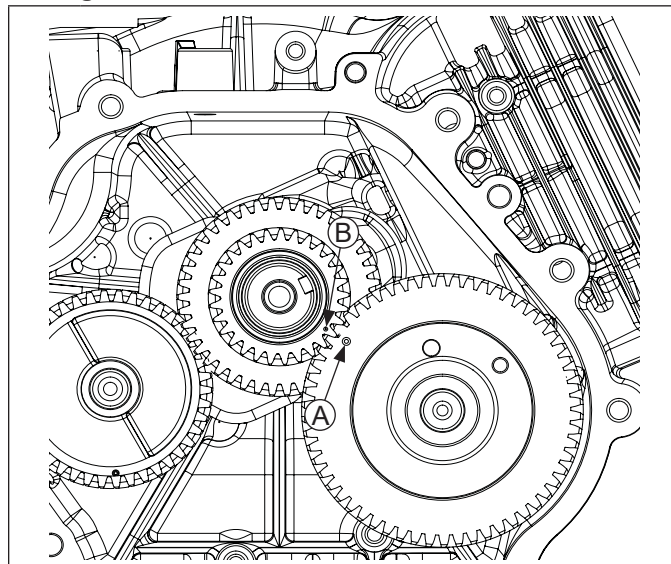

<b>A</b>	Camshaft Gear Timing Mark	<b>B</b>	Camshaft Drive Gear on Crankshaft Timing Mark
----------	---------------------------	----------	---

1. Lubricate face and stem of each tappet with engine oil. Install each into their respective bores.
2. Lubricate camshaft bearing surfaces and cam lobes as well as camshaft bore in crankcase with engine oil.
3. Rotate crankshaft to TDC so timing mark (dimple) on smaller crankgear is in 4 o'clock position. Install camshaft into crankcase, aligning timing marks on two gears.
4. Install original shims on crankshaft.

## Install Oil Fill Tube

### Details

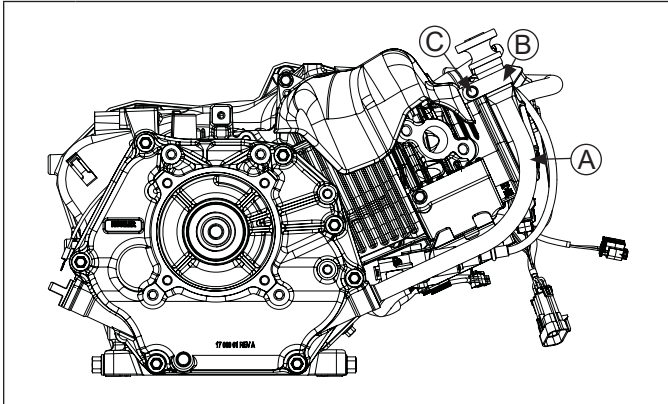

<b>A</b>	Oil Fill Tube	<b>B</b>	Oil Fill Tube Bracket
<b>C</b>	Bracket Screw		

1. If oil fill tube was removed from closure plate, apply a small amount of Loctite® 620™ (or equivalent) to end of tube, then press into closure plate until tube bead seats in closure plate. Tube should be parallel to closure plate PTO face.
2. Place bracket over tube and secure with bracket screw. Tighten screw until bracket is tight all around tube; then torque to 5.4 N·m (48 in. lb.).

## Install Closure Plate

### Torque Sequence

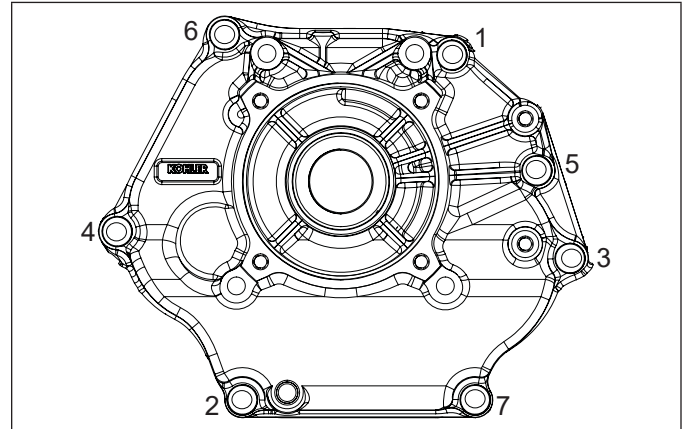

1. Check to make sure sealing surfaces of crankcase and closure plate are clean and free of nicks/burrs.
2. Install two dowel pins into locations shown in crankcase. Install new closure plate gasket (dry) onto dowel pins.
3. Install closure plate to crankcase. Carefully seat ends of camshaft and balance shaft into their mating bearings.
4. Install screws securing closure plate to crankcase. Torque screws in sequence shown to 24 N·m (212 in. lb.).

# Reassembly

## Cylinder Head Components

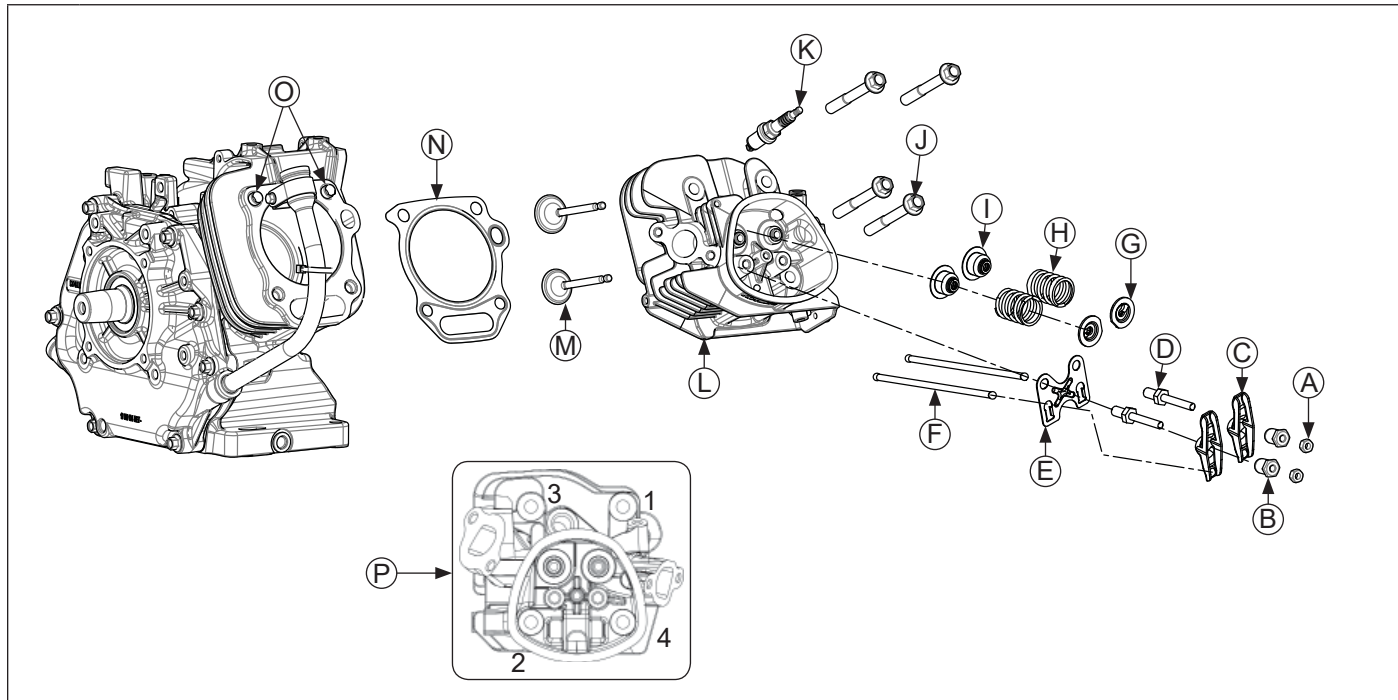

<b>A</b>	Hex Jam Nut	<b>B</b>	Rocker Arm Pivot Adjuster	<b>C</b>	Rocker Arm	<b>D</b>	Rocker Arm Stud
<b>E</b>	Push Rod Guide	<b>F</b>	Push Rod	<b>G</b>	Valve Spring Retainer	<b>H</b>	Valve Spring
<b>I</b>	Valve Stem Seal	<b>J</b>	Cylinder Head Screw	<b>K</b>	Spark Plug	<b>L</b>	Cylinder Head
<b>M</b>	Valve	<b>N</b>	Cylinder Head Gasket	<b>O</b>	Dowel Pin	<b>P</b>	Torque Sequence

### Assemble Cylinder Head

**NOTE:** Engine utilizes valve stem seals on valves. Always use a new seal when valves are installed in cylinder head. Never reuse old seals.

1. Install valves into their respective positions.
2. Install new valve seals on stem of valves.
3. Install valve springs and retainers into their respective locations in cylinder head. Support valve heads from underneath. Using hand pressure, compress each valve spring and slide each retainer onto valve stem to lock in place.

### Install Cylinder Head

1. Check to make sure there are no nicks or burrs on sealing surfaces of cylinder head or crankcase.
2. Rotate crankshaft to position piston at TDC on compression stroke.
3. Install dowel pins into recesses around upper cylinder head bolt holes.
4. Install a new cylinder head gasket.
5. Apply clean engine oil under head of each cylinder head screw.
6. Install cylinder head and start screws. Finger tighten screws, then torque screws in increments using sequence shown. Torque screws first to 25 N·m (221 in. lb.), then finally to 57.5 N·m (509 in. lb.).

## Install Push Rods and Rocker Arms

NOTE: Push rods should always be installed in original location.

- Identify proper position of each push rod. Dip ends of push rods in engine oil and install them in their respective locations, seating each into tappet socket.
- Install push rod guide plate, aligning holes for rocker arm studs. Screw in rocker arm studs and torque to 13.6 N·m (120 in. lb.).
- Assemble rocker arms, rocker arm pivot adjusters, and hex jam nuts onto studs and push rods. Finger tighten rocker arm pivot jam locknuts.
- Adjust valve tappet clearance as follows:
  - Make sure piston is still at top of compression stroke.
  - Insert a flat feeler gauge between rocker arm and valve stem. Recommended valve to rocker arm clearance for both intake and exhaust is 0.076-0.127 mm (0.003-0.005 in.)(Cold).
  - Adjust clearance as required by loosening hex jam nut and turning rocker arm pivot adjuster. Turn clockwise to decrease clearance. Turn counterclockwise to increase clearance.
  - Hold rocker arm pivot adjuster from turning and tighten hex jam nut. Torque hex jam nut to 10 N·m (89 in. lb.).
  - Recheck clearance is correct.
- Set gap of a new spark plug to 1.11 mm (0.044 in.).
- Install spark plug in cylinder head and torque to 27 N·m (20 ft. lb.).

## Install Valve Cover

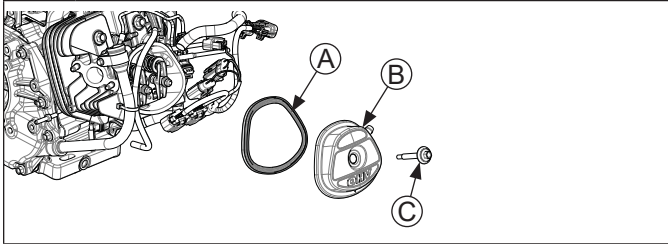

<b>A</b>	Valve Cover Gasket	<b>B</b>	Valve Cover
<b>C</b>	Valve Cover Seal Screw Assembly		

- Install a new valve cover gasket onto valve cover.
- Position valve cover/gasket assembly on head. Install screw and washer; torque screw to 10 N·m (89 in. lb.).

## Install Wiring Harness

Route wiring harness through castings on crankcase. Direct green wire toward oil level switch. Feed this wire through clip secured to crankcase. Connect oil level switch green wire to wiring harness.

## Flywheel Components

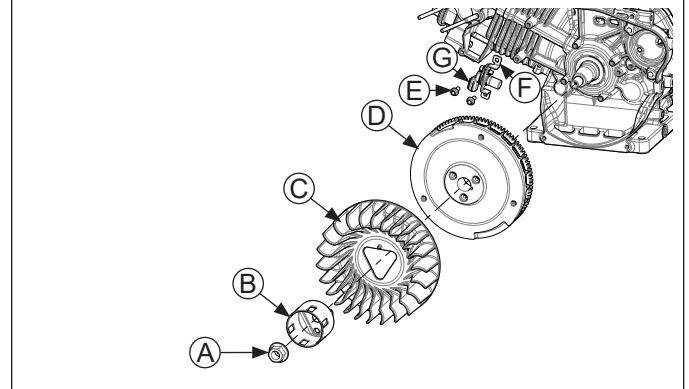

<b>A</b>	Flywheel Retaining Nut	<b>B</b>	Drive Cup
<b>C</b>	Flywheel Fan	<b>D</b>	Flywheel
<b>E</b>	Crankshaft Position Sensor Bracket Screw	<b>F</b>	Crankshaft Position Sensor Bracket
<b>G</b>	Crankshaft Position Sensor		

## Install Flywheel

	<b>CAUTION</b>
	Damaging Crankshaft and Flywheel can cause personal injury.
Using improper procedures can lead to broken fragments. Broken fragments could be thrown from engine. Always observe and use precautions and procedures when installing flywheel.	

NOTE: Before installing flywheel make sure crankshaft taper and flywheel hub bore are clean, dry, and completely free of lubricants. Presence of lubricants can cause flywheel to be overstressed and damaged when nut is torqued to specification.

NOTE: Make sure flywheel key is installed properly in keyway. Flywheel can become cracked or damaged if key is not installed properly.

- Install woodruff key into keyway of crankshaft. Make sure key is properly seated and parallel with taper of shaft.
- Install flywheel onto crankshaft, being careful not to shift position of woodruff key.
- Install fan bosses into matching holes in flywheel.
- Position drive cup on flywheel, engaging boss on its base with corresponding hole in fan. Hold in position and install nut. Finger tighten to keep cup indexed.
- Use a flywheel holding tool and torque wrench to tighten flywheel nut. Torque nut to 113 N·m (1000 in. lb.).

# Reassembly

## Install Crankshaft Position Sensor

NOTE: Ensure all parts are clean, undamaged and free of debris and make sure electrical connectors have seal in place.

NOTE: When mounting ground wire on bottom screw of bracket, ensure ground wire is routed outside and away from flywheel.

1. Install crankshaft position sensor to bracket. Torque screw to 4.2 N·m (37 in. lb.).
2. Install crankshaft position sensor and bracket assembly to crankcase posts.
3. Secure bracket assembly to crankcase posts. Torque bracket screws to 7.3 N·m (65 in. lb.).
4. Push electrical connector on crankshaft position sensor making sure a good connection is made.

## Blower Housing Components

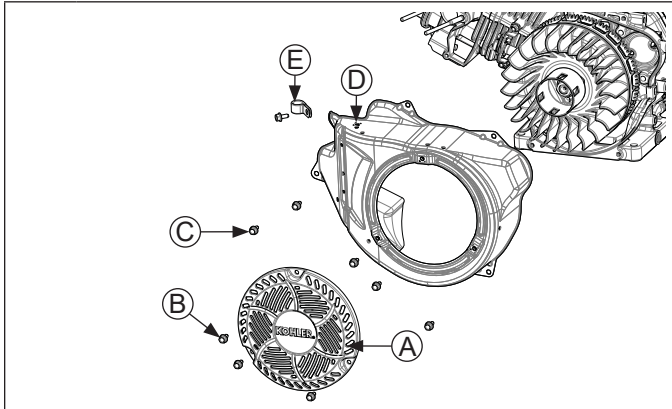

<b>A</b>	Blower Housing Screen	<b>B</b>	Screw
<b>C</b>	Screw	<b>D</b>	Blower Housing
<b>E</b>	Clamp		

## Install Blower Housing

Install blower housing on crankcase with screws. Torque screws to 10 N·m (89 in. lb.).

## Install Blower Housing Screen

Install blower housing screen on blower housing using screws. Torque screws to 7.3 N·m (65 in. lb.).

## Install Wiring Harness Clamp

Insert wiring harness into clamp and install clamp with wiring harness to blower housing. Tighten screw securely.

## Install Cylinder Shield

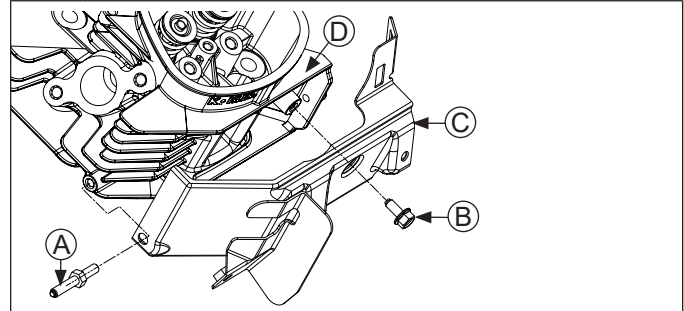

<b>A</b>	Ground Stud	<b>B</b>	Screw
<b>C</b>	Cylinder Shield	<b>D</b>	Cylinder Head

1. Install cylinder shield on cylinder head; secure with ground stud and screw as shown. Torque stud and screw to 8 N·m (71 in. lb.).
2. If removed, install ignition coil onto cylinder shield. Torque screw to 10.2 N·m (90 in. lb.).
3. Plug connector into ignition coil.

## Fuses and ECU Components

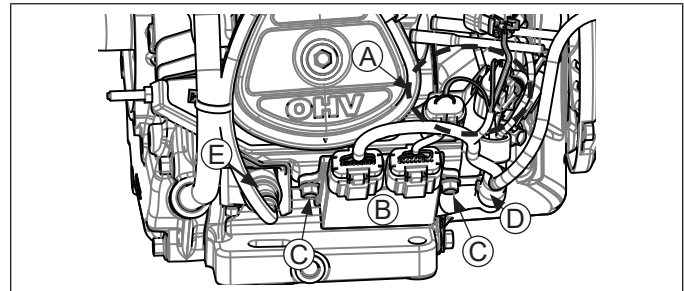

<b>A</b>	Fuses/Fuse Holders	<b>B</b>	ECU
<b>C</b>	Screw	<b>D</b>	Cable Clip
<b>E</b>	Ignition Coil		

## Install Electronic Control Unit (ECU)

NOTE: ECU pins should be coated with a thin layer of electrical grease to prevent fretting and corrosion and may need to be reapplied if ECU is being reused.

1. Connect Black and Grey electrical connectors. Connectors and ECU are keyed in such a way so they cannot be installed incorrectly.
2. Install ECU to cylinder shield using screws. Wire harness clip secures with screw closest to flywheel. Torque screws to 8 N·m (71 in. lb.).
3. Install fuses into holders on cylinder shield.

## Install Upper Heat Shield and Engine Temperature Sensor

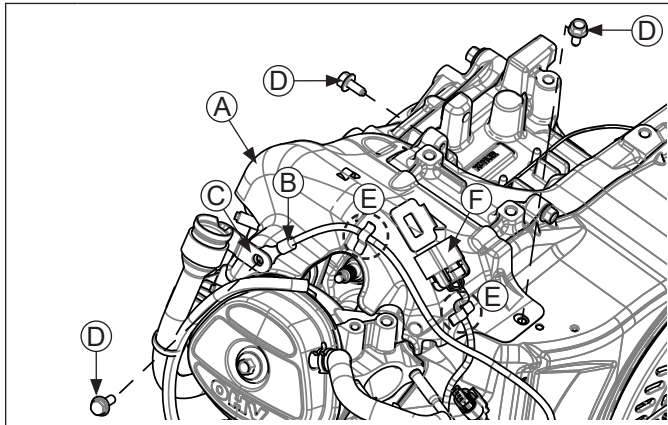

A	Upper Heat Shield	B	Engine Temperature Sensor
C	Dipstick Tube Bracket	D	Screw
E	Clip	F	Oxygen Sensor Connector

1. Position upper heat shield on crankcase and start 2 screws securing to crankcase. Do not tighten screws at this time.
2. Position engine temperature sensor between dipstick tube bracket and upper heat shield; start screw to secure. Torque this screw to 11.9 N·m (105 in. lb.).
3. Fully tighten and torque 2 screws securing shield to crankcase to 6.2 N·m (55 in. lb.) into new holes or 4.0 N·m (35 in. lb.) into used holes.
4. Install engine temperature wire under upper heat shield clip. Install oxygen sensor wire under upper heat shield clip.

## Install Fuel Injector and TMAP

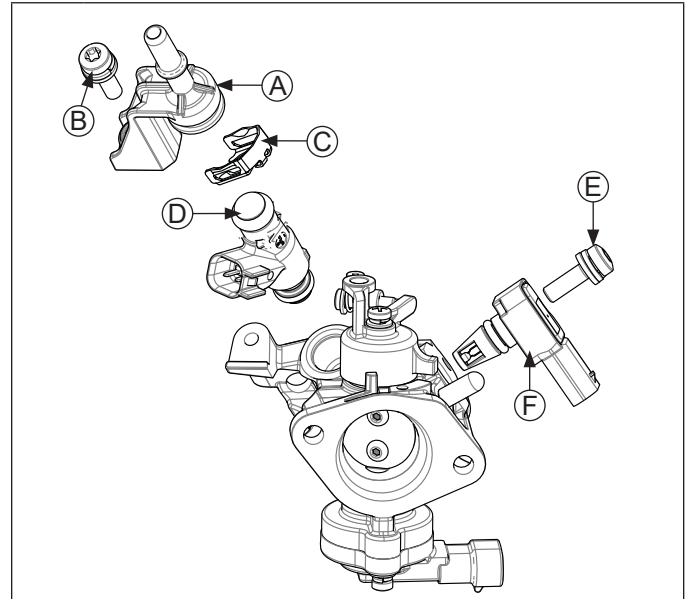

A	Fuel Injector Cap	B	Screw
C	Metal Retaining Clip	D	Fuel Injector
E	Screw	F	TMAP

## Install Temperature/Manifold Absolute Pressure (TMAP) Sensor

NOTE: Ensure all parts are clean, undamaged, and free of debris and make sure electrical connector has seal in place.

1. Lightly oil TMAP sensor O-ring and push sensor into bore in throttle body.
2. Torque screw to 7.3 N·m (65 in. lb.).
3. Push electrical connector on TMAP sensor making sure a good connection is made. Slide down lock tab.

## Install Fuel Injector

NOTE: Ensure all parts are clean, undamaged, and free of debris and make sure electrical connectors have seal in place.

NOTE: O-rings and retaining clip should be replaced any time fuel injector is separated from its normal mounting position.

1. Lightly lubricate fuel injector O-rings with clean engine oil.
2. Push retaining clip onto fuel injector, aligning clip.
3. Press fuel injector cap onto fuel injector until retaining clip snaps into place.
4. Press fuel injector into bore in throttle body and rotate to original position, as noted in Disassembly/Inspection and Service.
5. Install fuel injector cap screw into throttle body and torque to 7.3 N·m (65 in. lb.).
6. Push electrical connector on fuel injector making sure a good connection is made.



# Reassembly

## Install Throttle Body Assembly

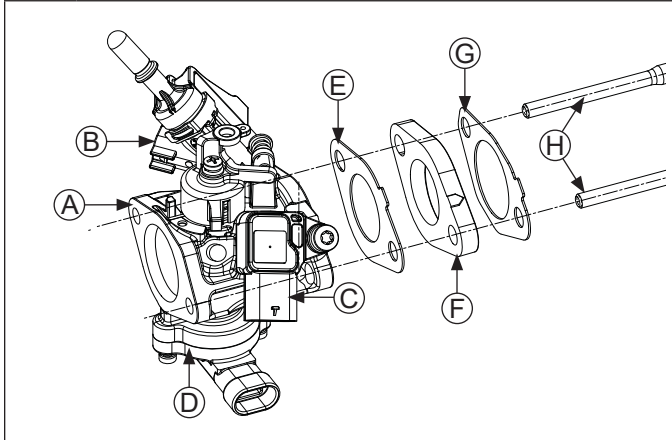

<b>A</b>	Throttle Body	<b>B</b>	Fuel Injector
<b>C</b>	TMAP	<b>D</b>	Throttle Position Sensor (TPS)
<b>E</b>	Insulator to Throttle Body Gasket	<b>F</b>	Insulator
<b>G</b>	Insulator to Cylinder Head Gasket	<b>H</b>	Intake Studs

NOTE: Ensure all parts are clean, undamaged, and free of debris and make sure electrical connector has seal in place.

1. Install new insulator to cylinder head gasket, insulator, and insulator to throttle body gasket as shown.  
Ensure notched section of each gasket is outward and points to flywheel side.  
Ensure arrow on insulator points toward cylinder head.
2. Install throttle body on studs.
3. Push electrical connector onto throttle position sensor (TPS) making sure a good connection is made.

## Install Air Inlet Elbow

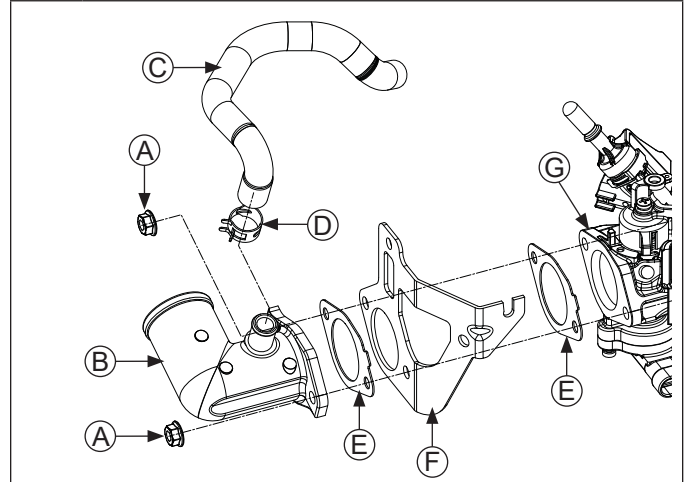

<b>A</b>	Nut	<b>B</b>	Air Inlet Elbow
<b>C</b>	Breather Hose with Sleeve	<b>D</b>	Clamp
<b>E</b>	Throttle Body Gasket	<b>F</b>	Governor Bracket
<b>G</b>	Throttle Body		

1. Install a new throttle body gasket onto mounting studs followed by air inlet elbow.
2. Install governor bracket onto mounting studs followed by a new throttle body gasket.  
Ensure notched section of each gasket is outward and points to flywheel side.
3. Install air inlet elbow onto mounting studs and secure with nuts. Torque nuts to 8 N·m (71 in. lb.).
4. Attach breather hose onto air inlet elbow connection port; position hose clamp to secure. Connect opposite end of breather hose to valve cover.

## Oxygen Sensor

Install oxygen sensor, torque to 18 N·m (159 in. lb.), and connect to wire harness.

## External Engine Components

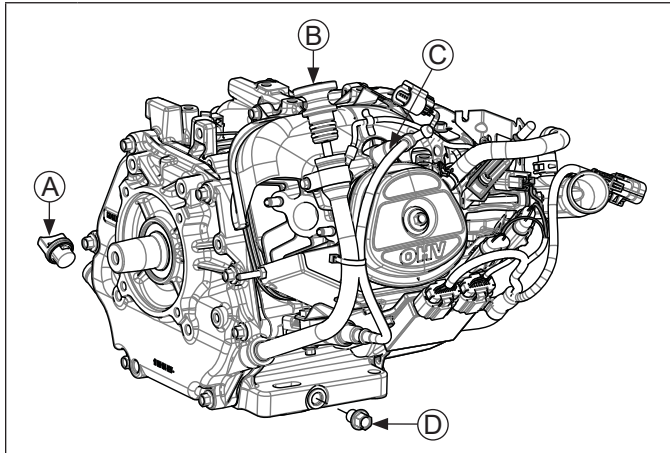

<b>A</b>	Oil Fill Plug	<b>B</b>	Dipstick
<b>C</b>	Spark Plug Lead	<b>D</b>	Oil Drain Plug

### Connect Spark Plug Lead

Connect lead to spark plug. Secure lead to dipstick tube with a new wire tie.

### Prepare Engine for Operation

**NOTE:** If ECU, throttle body, TPS, or fuel pump were replaced, an ECU Reset and TPS Learn is required. Refer to EFI System, ECU Reset and TPS Learn procedure.

Engine is now reassembled. Before starting or operating engine be sure to do following:

1. Make sure all hardware is properly torqued.
2. Make sure oil drain plugs, oil fill plugs and Oil Sentry™ wire lead bushing are tightened securely.
3. Fill crankcase with correct oil. Refer to Maintenance and Lubrication System for oil recommendations and procedures.
4. Ensure all electrical connectors are installed and secure.
5. Make sure all fuel and vent lines are connected. Refer to equipment manufacturer's manual for Reassembly information.
6. Reinstall engine into application and test operation. Refer to equipment manufacturer's manual for details.



1P17 690 14



8 85612 52081 4

Pagination Page

### **⚠ DANGER**

- See General Warnings on page 1-1.

### **⚠ WARNING**

- See General Warnings on page 1-1.

## GENERAL INFORMATION

---

### REFRESHMENT CENTER COMPARTMENTS

#### **Cold Storage Compartments**

The cold storage compartments are designed to carry canned beverages and cooling ice. Pre-packaged, non-hazardous foods and snacks can also be served from these compartments. We recommend they be kept in original packaging if placed directly on the ice, so that food will remain dry.

Pre-cooling the canned beverages will minimize the amount of ice required to keep the product cool. Maintaining ice in the cold storage compartments when they are not in service will help to maintain a colder temperature when the unit is put back into service.

### **⚠ WARNING**

- Operate vehicle only with all compartment loads equally distributed.
- Do not use the cold storage compartments to store unprotected food, or ice that is intended for human consumption. Failure to heed this warning can result in food poisoning.

#### **Consumable Ice Compartments**

The consumable ice compartments, located in the rear driver and passenger sides of the Cafe Express refreshment center should be used for consumable ice only. In order to prevent contamination of consumable ice, do not place food in these compartments. Consumable ice should not be stored in any other compartment of the Cafe Express refreshment center.

#### **Trash Compartment**

The trash compartment is located in the rear of the base unit. The trash bin should be lined with a disposable plastic bag to maintain cleanliness. This compartment should not be used for storing or transporting consumable ice, drinks, or food.

## CLEANING

---

### INTERIOR ALUMINUM SURFACES

The interior surfaces of the refreshment center should be cleaned and sanitized daily with an approved product before being used. Check with your local Health Department for rules and regulations in your area.

### EXTERIOR ALUMINUM SURFACES

The exterior surfaces should be cleaned on a daily basis using a soap and water solution. Periodic cleaning with an aluminum or stainless steel cleaner is recommended.

## **CAUTION**

- Using abrasive cleaners on aluminum will damage or scratch the surface. Use a soft cloth with an industrial type aluminum cleaner/polish to clean the aluminum surfaces.
- Do not use steel wool on refreshment center aluminum surfaces.

## **DRAINS**

The drains should be flushed with a hose on a daily basis. Periodically, the drains should be cleaned and sanitized.

## **REFRESHMENT CENTER DOORS**

The sliding doors should be cleaned daily with a mild soap and water solution. Dry with a clean, damp chamois. Do not use window cleaning sprays or paper towels.

## **CANOPY COVER**

Periodically clean the canopy cover by spraying the fabric with water and allowing fabric to dry on the canopy frame.

## **WINDSHIELD**

Use only mild liquid dishwasher soap with a sponge or soft cloth for cleaning the windshield.

## **CAUTION**

- Do not use glass-cleaning products on the windshield.

## **CANOPY**

---

See General Warnings on page 1-1.

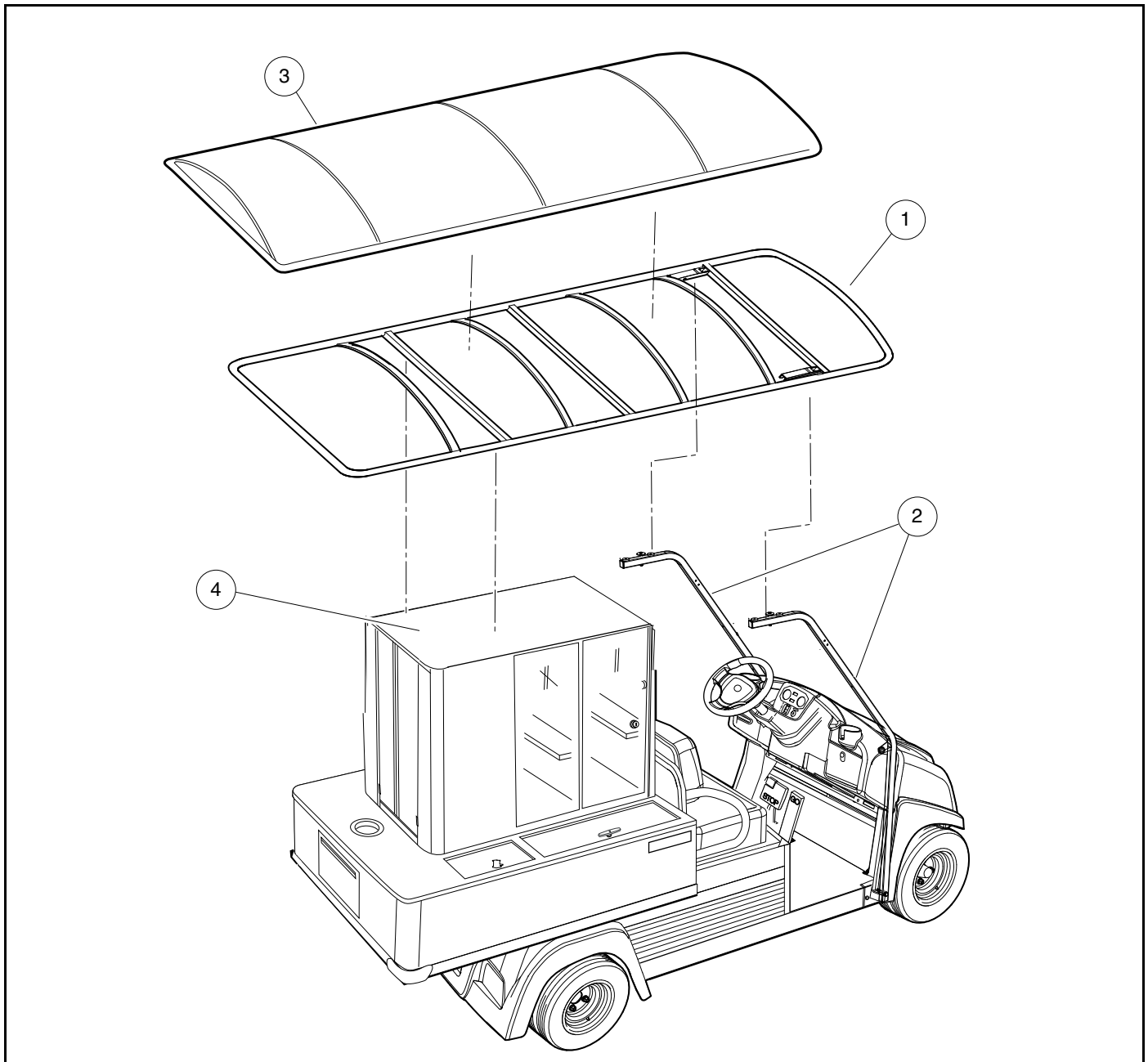

3069

Figure 19-1 Canopy – Café Express

## CANOPY REMOVAL

1. Unhook retention cord loops from underside of canopy frame (1).
2. Release the hook-and-loop strip at the rear of the canopy frame (1).
3. Slip each end of canopy (3) off the frame (1) and remove canopy. **See following NOTE.**

**NOTE:** The canopy (3) is attached to the frame in a manner similar to a “fitted” bed sheet on a mattress.

## CANOPY INSTALLATION

**NOTE: Canopy Orientation:** The canopy (3) fits onto the frame one way. The rear has open corners and also has a hook-and-loop strip in the center.

1. Place canopy (3) onto frame (2) and slip the front edge over the front of the frame.
2. Pull canopy (3) tight towards the rear and secure over frame with the hook-and-loop strip.
3. Secure retention cord loops to the hooks on the underside of canopy frame.

## CANOPY FRAME REMOVAL

1. Remove canopy from frame. **See Canopy Removal on page 19-3.**
2. Remove clevis pins securing canopy frame (1) to front supports (2) (**Figure 19-1, Page 19-3**).
3. Remove hardware securing canopy frame (1) to upper cabinet (4).
4. With the aid of an assistant, lift frame (1) off upper cabinet.

## CANOPY FRAME INSTALLATION

1. With the aid of an assistant, lift and place canopy (1) onto vehicle.
2. Install hardware securing canopy frame (1) to upper cabinet (4) (**Figure 19-1, Page 19-3**). Tighten only finger-tight at this time.
3. Install clevis pins securing canopy frame (1) to front supports (2). Fold spring retainer down to lock each clevis pin into place.
4. Tighten hardware at upper cabinet to 40 in·lb (4.5 N·m).
5. Install canopy on frame. **See Canopy Installation on page 19-4.**



## UNIT MAINTENANCE AND REPAIRS

See General Warnings on page 1-1.

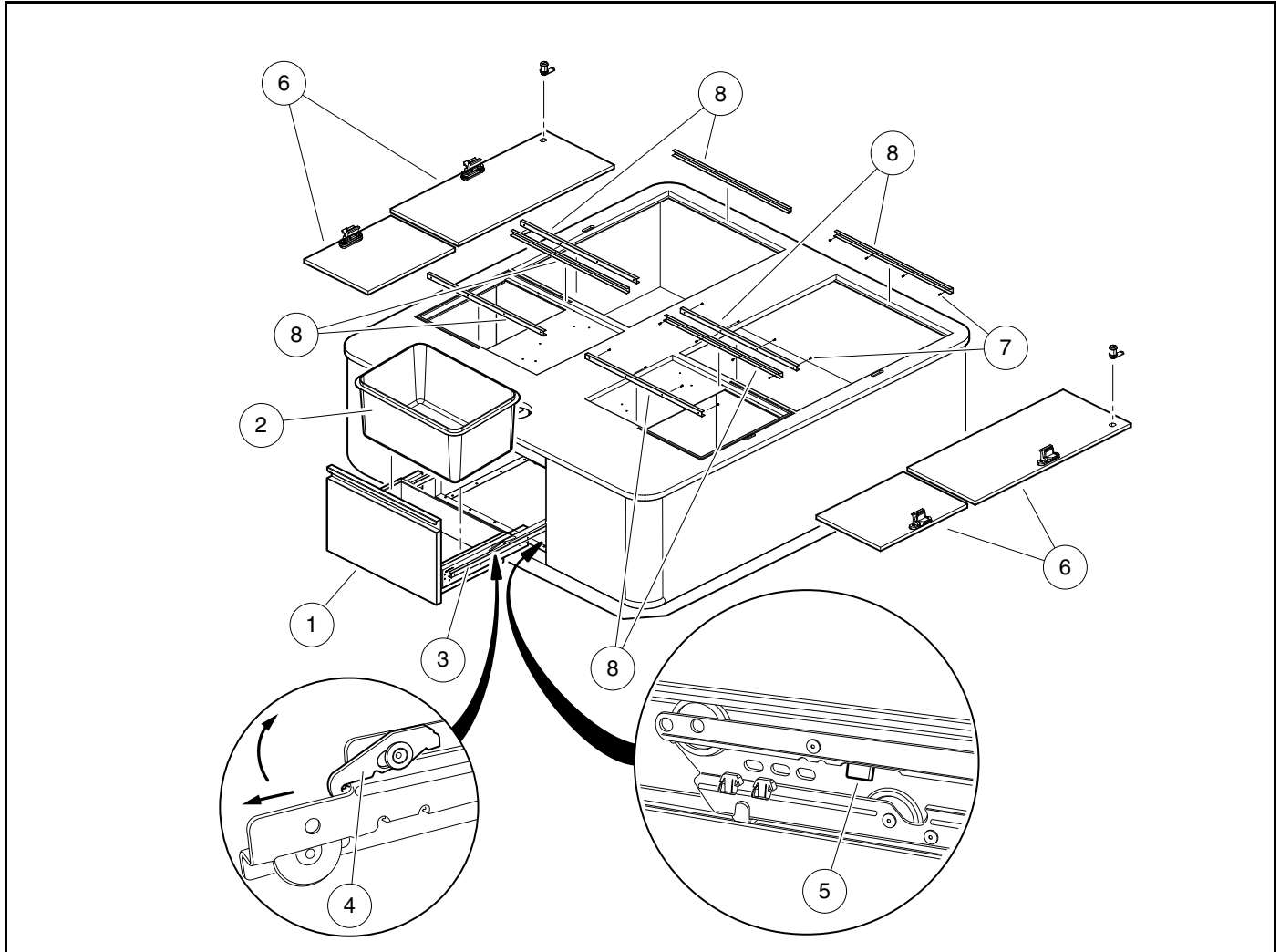

3070

Figure 19-2 Lower Cabinet – Café Express

### TRASH DRAWER

See General Warnings on page 1-1.

#### Trash Drawer Removal

1. Pull drawer (1) out as far as it will go and remove the trash can (2) (Figure 19-2, Page 19-5).
2. Unlock drawer (1) from track slides (3).
  - 2.1. Push the white locking tab (4) towards the drawer front to disengage the track slide. **See following NOTE.**

**NOTE:** The white locking tab (4) slides and pivots on the pin that retains it.

- 2.2. Then, rotate the white locking tab (4) up to clear the track slide (3).
3. Lift drawer (1) up and pull out to remove drawer.

4. To remove the track slide (3), push up and hold the upper gray tab (5) near the rear of the track slide and pull slide straight out. Repeat for other side.

### Trash Drawer Installation

Installation is reverse of removal. **See following WARNING.**

### **⚠ WARNING**

- Ensure both white locking tabs (4) are engaged before returning vehicle to service.

## SLIDE DOORS

See General Warnings on page 1-1.

### Horizontal Slide Door Removal

1. Push slide door (6) open (**Figure 19-2, Page 19-5**).
2. Remove screws (7) securing tracks (8) to lower cabinet.
3. Remove door (6) and tracks (8) from lower cabinet.

### Horizontal Slide Door Installation

1. Place tracks (8) onto door (6), maintaining access to the front screw hole, and install into lower cabinet (**Figure 19-2, Page 19-5**).
2. Secure tracks (8) with a screw (7) in each track finger-tight.
3. Push door (6) fully open and install remaining screws (7). Tighten screws (7) firmly; being careful not to over-tighten and strip the plastic.

### Vertical Slide Door Removal

1. Push slide doors (9) open (**Figure 19-3, Page 19-7**).
2. Remove screws (10) securing track (11) to top of upper cabinet, moving doors (9) as required.
3. Remove doors (9) and track (11) from upper cabinet.
4. Repeat for other doors if required.

### Vertical Slide Door Installation

1. Place track (11) onto doors (9) and install into upper cabinet (**Figure 19-3, Page 19-7**).
2. Secure track (11) with a couple of screws (10) finger-tight.
3. Move doors (9) as required and install remaining screws (10). Tighten screws (10) firmly; being careful not to over-tighten and strip the plastic.

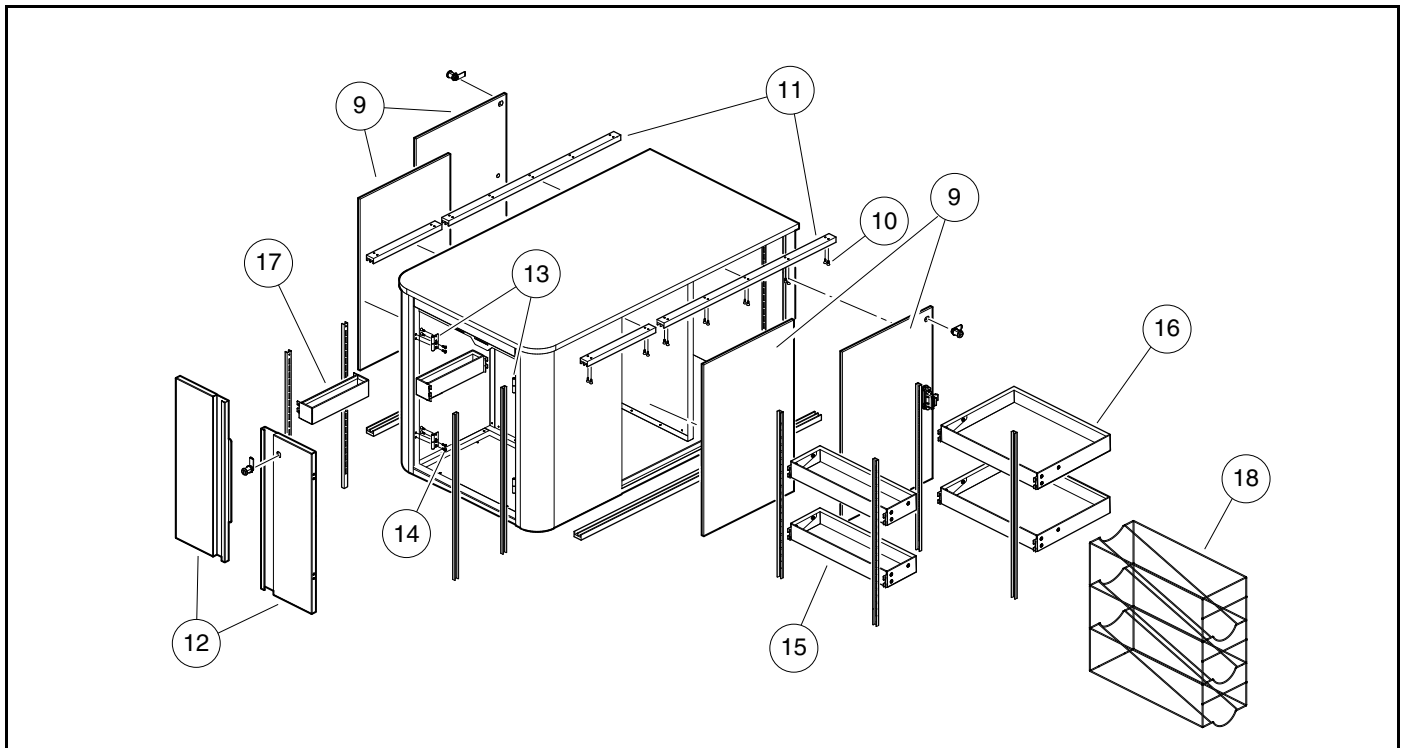

3071

Figure 19-3 Upper Cabinet – Café Express

## COFFEE DOORS

See General Warnings on page 1-1.

### Coffee Door Removal

**NOTE:** Coffee doors use flag hinges that separate easily. For temporary removal of the coffee doors (e.g. cleaning), simply open the door and lift straight up.

1. Open coffee door (12) to access hinges (13) (**Figure 19-3, Page 19-7**).
2. Remove screws (14) securing coffee door (12) to hinges (13).
3. Remove coffee door (12). Repeat for other door if required.

### Coffee Door Installation

1. Installation is reverse of removal.
2. Tighten screws (14) firmly; being careful not to over-tighten and strip the threads.

## CONTAINERS

See General Warnings on page 1-1.

### Container Removal

**NOTE:** The hanger brackets used are a wedge-fit.

1. Open vertical sliding doors (9) of upper cabinet for medium (15) and large (16) containers (**Figure 19-3, Page 19-7**). Open coffee doors (12) of upper cabinet for small containers (17).
2. Unlock the hanger bracket on each side of container (15, 16, or 17) by striking bracket straight up to release.
3. Grasping both sides of container (15, 16, or 17), lift both sides straight up and pull straight out to unhook hanger brackets from slots.
4. Remove container (15, 16, or 17) from upper cabinet.

### Container Installation

Installation is reverse of removal. Ensure hanger brackets are wedged in tight. **See following WARNING.**

#### **WARNING**

- Ensure containers (15, 16, or 17) are fully wedged into place before returning vehicle to service.

## CUP HOLDER

See General Warnings on page 1-1.

### Cup Holder Removal

**NOTE:** The hanger brackets used are a wedge-fit.

1. Open vertical sliding doors (9) of upper cabinet (**Figure 19-3, Page 19-7**).
2. Unlock the hanger bracket on each side of cup holder (18) by striking bracket straight up to release.
3. Grasping both sides of cup holder (18), lift both sides straight up and pull straight out to unhook hanger brackets from slots.
4. Remove cup holder (18) from upper cabinet.

### Cup Holder Installation

Installation is reverse of removal. Ensure hanger brackets are wedged in tight. **See following WARNING.**

#### **WARNING**

- Ensure cup holder (18) is fully wedged into place before returning vehicle to service.

# SECTION 20 — WIRING DIAGRAMS

## GENERAL INFORMATION

### Wire Description

EXAMPLE: 18\_GRN\_RED

- 18 = 18 gauge wire
- GRN\_RED = Green wire with red stripe

### Wire Colors

**NOTE:** The following colors will be represented as a black wire in the wiring diagrams:

- Black
- White
- Yellow
- White with Black Stripe

Abbreviation	Wire Color
BLK	Black
BLU	Blue
LT BLU	Light Blue
BRN	Brown
GRAY	Gray
GRN	Green
ORG	Orange
PINK	Pink
PUR	Purple
RED	Red
TAN	Tan
WHT	White
YEL	Yellow
BLK_LT_BLUE	Black with Light Blue Stripe
BLK_ORG	Black with Orange Stripe
BLK_PINK	Black with Pink Stripe
BLK_WHT	Black with White Stripe
BLK_YEL	Black with Yellow Stripe
BLU_WHT	Blue with White Stripe
BRN_WHT	Brown with White Stripe
GRN_RED	Green with Red Stripe

TABLE CONTINUED ON NEXT PAGE

GRN_WHT	Green with White Stripe
ORG_BLK	Orange with Black Stripe
ORG_WHT	Orange with White Stripe
PUR_WHT	Purple with White Stripe
RED_GRN	Red with Green Stripe
RED_WHT	Red with White Stripe
RED_YEL	Red with Yellow Stripe
WHT_BLK	White with Black Stripe

## PEDAL-START CONNECTOR PINOUTS

### PEDAL-START MAIN HARNESS CONNECTOR PINOUTS

To Connected Car

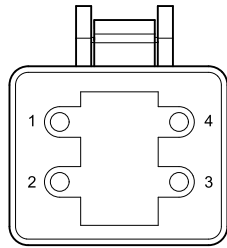

Pin	Wire Color	Description
1	Red	Power
2	Black	Ground
3	OPEN	OPEN
4	OPEN	OPEN

To Engine Harness

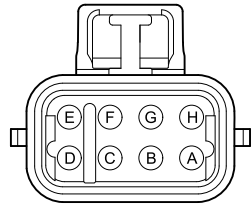

Pin	Wire Color	Description
A	Red	Switched 12V Power
B	Red	Constant 12V Power
C	OPEN	OPEN
D	Tan	Malfunction Indicator Light (MIL)
E	White	Ground Kill Wire
F	Green	Low Oil Light
G	Black / White	Fuel Pump
H	OPEN	OPEN

To Instrument Panel (IP) Harness

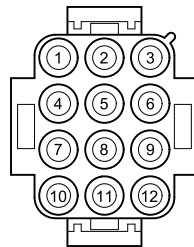

Pin	Wire Color	Description
1	Green / White	Headlights / Taillights
2	Green / Red	Headlight Switch Power
3	Red / Yellow	To Key Switch (M+)
4	OPEN	OPEN
5	Orange / White	Reverse Buzzer Power
6	Blue / White	Power
7	Black / White	Ground
8	Tan	Malfunction Indicator Light (MIL)
9	Purple / White	To FNR Harness Pin 3

TABLE CONTINUED ON NEXT PAGE

10	Orange / Black	Fuel Sending Unit Input
11	White	Hour Meter Input
12	Green	Low Oil Light

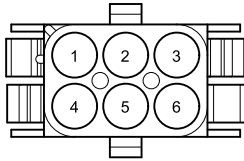
**To FNR Harness**

Pin	Wire Color
1	Black / Yellow
2	Orange
3	Purple / White
4	Black / Light Blue
5	Blue / White
6	Yellow

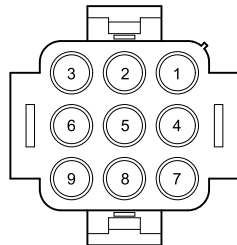
**To Accessories**

Pin	Wire Color	Description
1	Blue	Horn Power
2	Gray	To Rear Lights
3	Gray / Black	Brake Light Relay
4	White	To Rear Lights
5	OPEN	OPEN
6	Black	Ground
7	Brown	Power
8	Red	Right Turn Signal Power
9	Green	Left Turn Signal Power

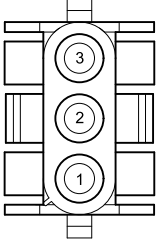

**To Brake Light Relay**

		
Pin	Wire Color	Description
1	Black	Ground
2	White / Black	Power
3	Gray / Black	To Accessories Pin 3

**To Fuel Pump**

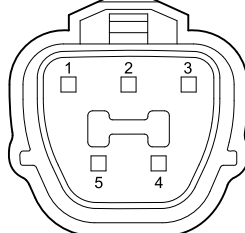
		
Pin	Wire Color	Description
1	Open	Open
2	Orange/Black	Sending Unit Positive (+)
3	Black	Sending Unit Negative (-)
4	Black/White	Fuel Pump Negative (-)
5	Red/White	Fuel Pump Positive (+)

**Fuel Pump Relay**

	
Pin	Wire Color
1	Green

TABLE CONTINUED ON NEXT PAGE

2	Black/White
3	Red/White
4	Open
5	Red

**Fuse Holder**

Pin	Wire Color
A	Red
B	Red/Black
E	Orange/White
F	Orange

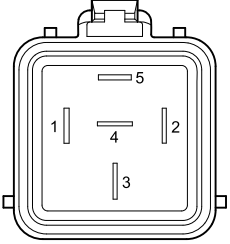
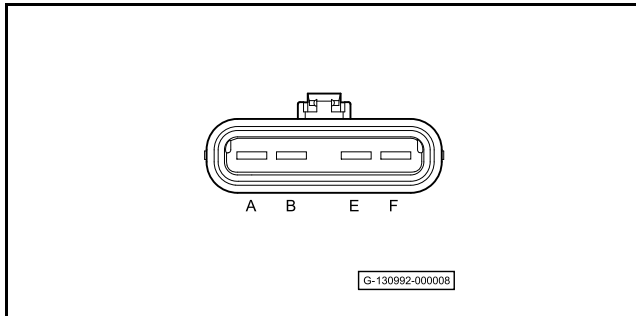
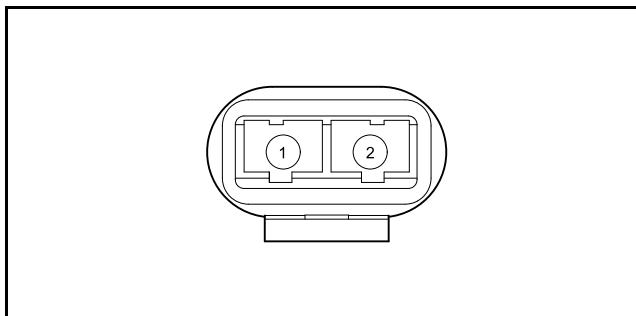
**Fuse Connector**

Pin	Wire Color
1	Red
2	Pink

## KEY-START CONNECTOR PINOUTS

### KEY-START MAIN HARNESS CONNECTOR PINOUTS

#### To Connected Car

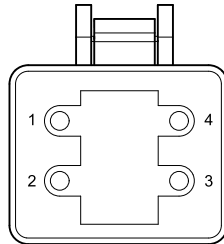

Pin	Wire Color	Description
1	Red	Power
2	Black	Ground
3	OPEN	OPEN
4	OPEN	OPEN

#### To Engine Harness

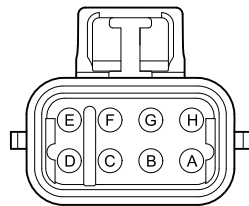

Pin	Wire Color	Description
A	Red	Switched 12V Power
B	Red	Constant 12V Power
C	OPEN	OPEN
D	Tan	Malfunction Indicator Light (MIL)
E	White	Ground Kill Wire
F	Green	Low Oil Light
G	Black / White	Fuel Pump
H	OPEN	OPEN

## To Instrument Panel (IP) Harness

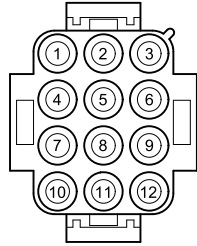

Pin	Wire Color	Description
1	Green / White	Headlights / Taillights
2	Green / Red	Headlight Switch Power
3	Red / Yellow	To Key Switch (M+)
4	OPEN	OPEN
5	Orange / White	Reverse Buzzer Power
6	Blue / White	Power
7	Black / White	Ground
8	Tan	Malfunction Indicator Light (MIL)
9	Purple / White	To FNR Harness Pin 3
10	Orange / Black	Fuel Sending Unit Input
11	White	Hour Meter Input
12	Green	Low Oil Light

## To FNR Harness

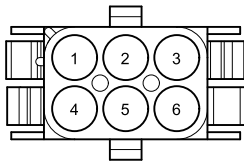

Pin	Wire Color
1	Black / Yellow
2	Orange
3	Purple / White
4	Black / Light Blue
5	Blue / White
6	Yellow

To Accessories

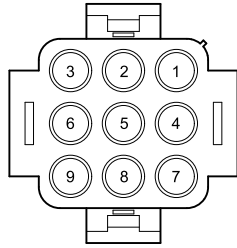

Pin	Wire Color	Description
1	Blue	Horn Power
2	Gray	To Rear Lights
3	Gray / Black	Brake Light Relay
4	White	To Rear Lights
5	OPEN	OPEN
6	Black	Ground
7	Brown	Power
8	Red	Right Turn Signal Power
9	Green	Left Turn Signal Power

To Brake Light Relay

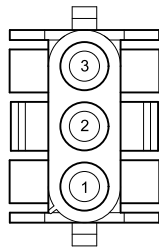

Pin	Wire Color	Description
1	Black	Ground
2	White / Black	Power
3	Gray / Black	To Accessories Pin 3

## To Fuel Pump

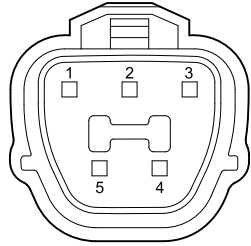

Pin	Wire Color	Description
1	Open	Open
2	Orange/Black	Sending Unit Positive (+)
3	Black	Sending Unit Negative (-)
4	Black/White	Fuel Pump Negative (-)
5	Red/White	Fuel Pump Positive (+)

## Fuel Pump Relay

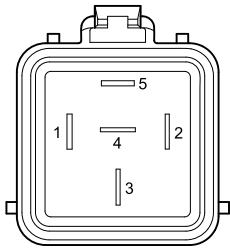

Pin	Wire Color
1	Green
2	Black/White
3	Red/White
4	Open
5	Red

**Fuse Holder**

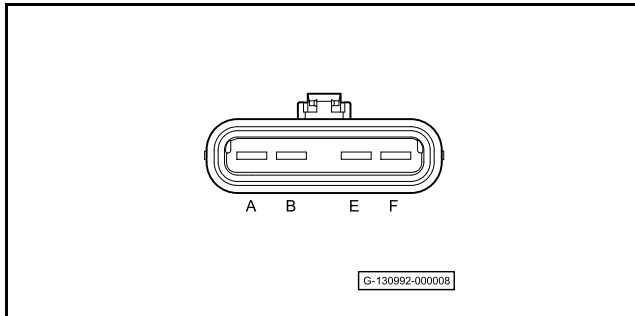

Pin	Wire Color
A	Red
B	Red/Black
E	Orange/White
F	Orange

**Fuse Connector**

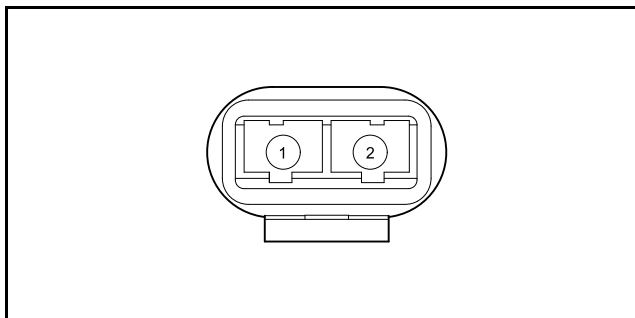

Pin	Wire Color
1	Red
2	Pink

**ENGINE HARNESS WIRING DIAGRAM TABLE**

Callout	Description
1	Red
2	Red/Black
3	Red/White
4	Yellow
5	Light Green
6	Dark Green
7	Dark Blue
8	Purple
9	Pink
10	Tan
11	White
12	Grey
13	Black
14	To Main Harness
15	Oil Level Switch
16	10-amp Fuse (Ignition Switch)
17	10-amp Fuse (Battery Power)
18	Black Connector
19	Grey Connector
20	Fuel Injector
21	Ignition Coil
22	Crankshaft Position Sensor
23	Oxygen Sensor
24	Throttle Position Sensor
25	TMAP Sensor
26	Engine Temperature Sensor
27	Diagnostic Connector



### GASOLINE: ENGINE HARNESS

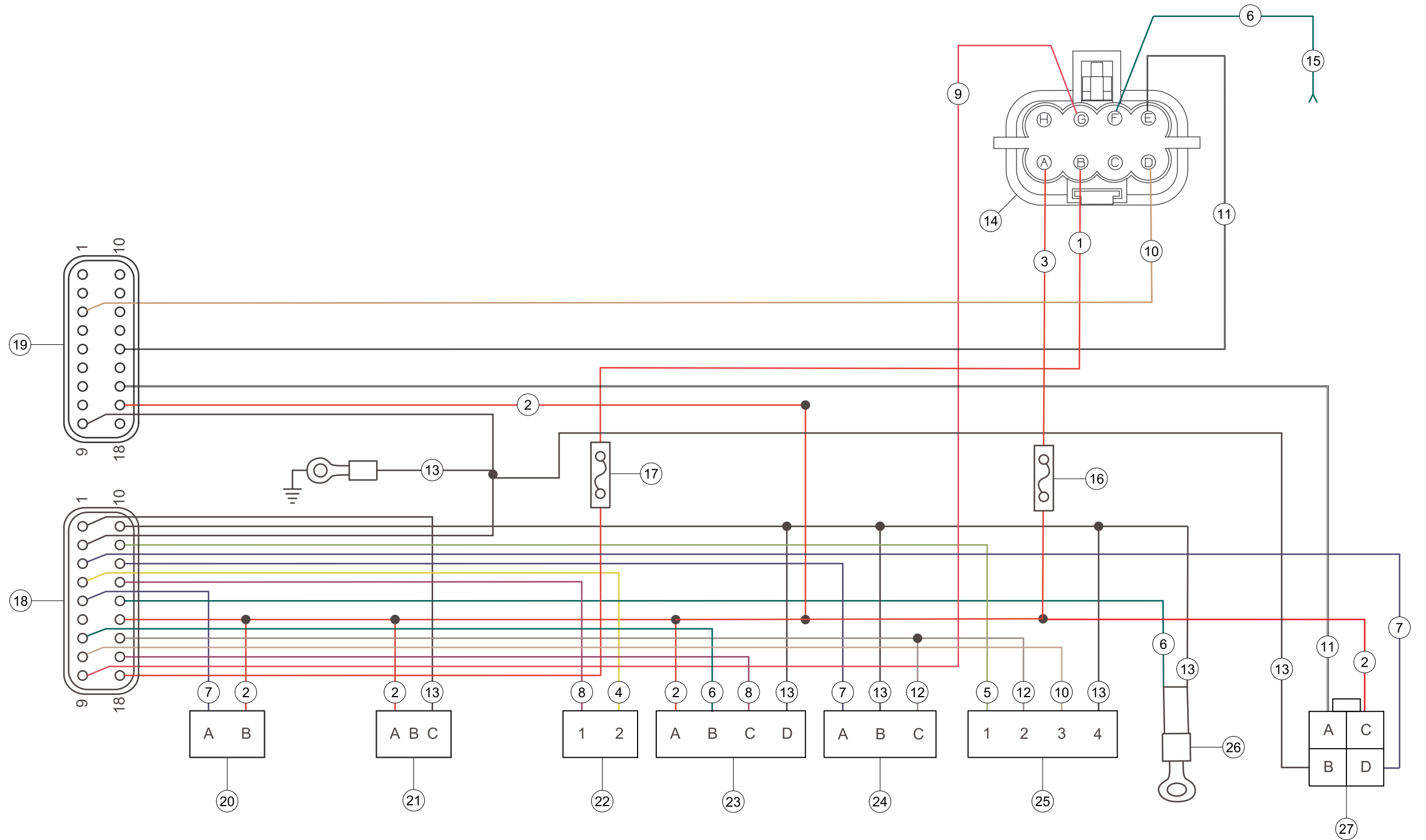

*(Page intentionally left blank.)*

# GASOLINE: PEDAL-START MAIN HARNESS

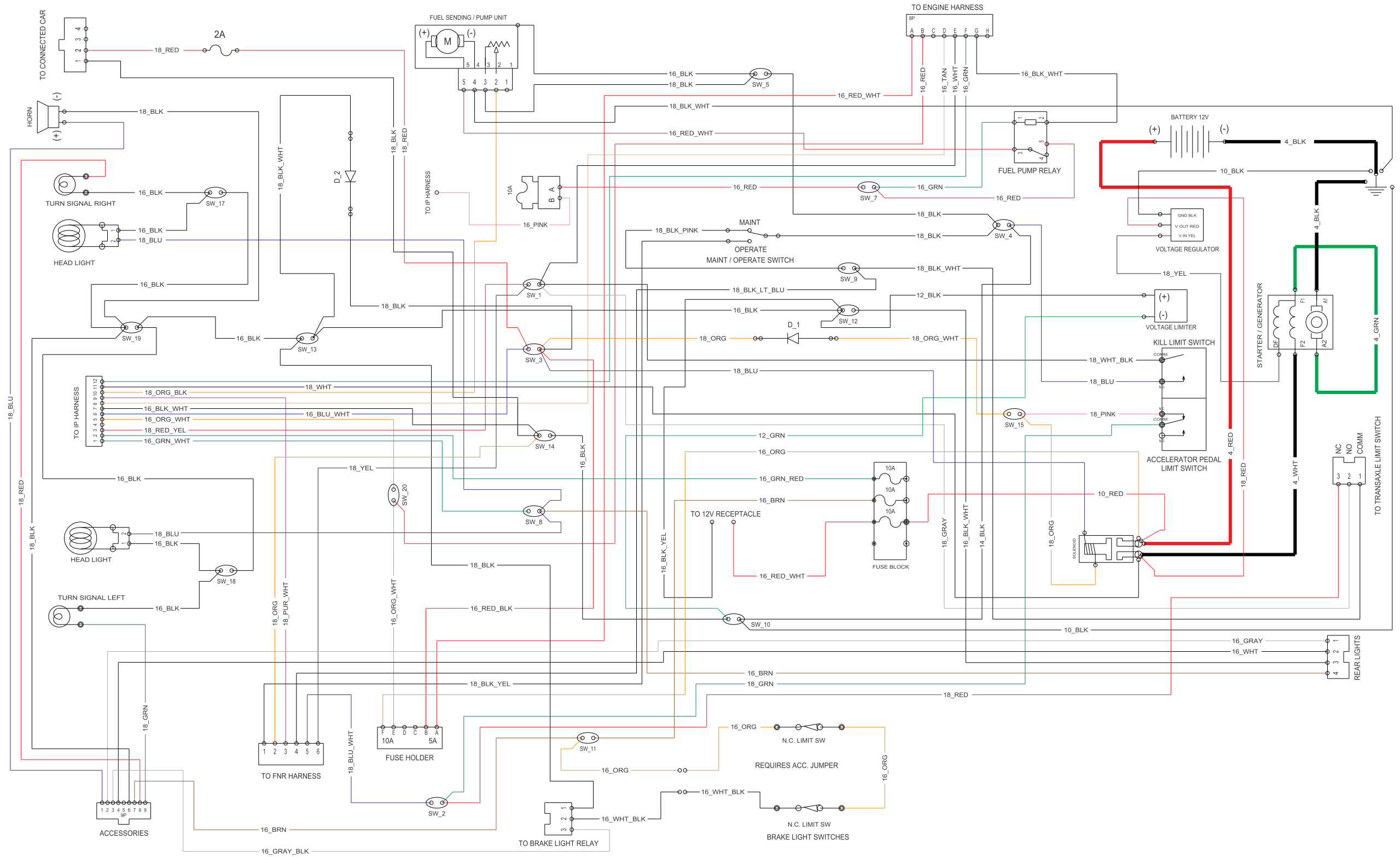

*(Page intentionally left blank.)*

# GASOLINE: INSTRUMENT PANEL HARNESS

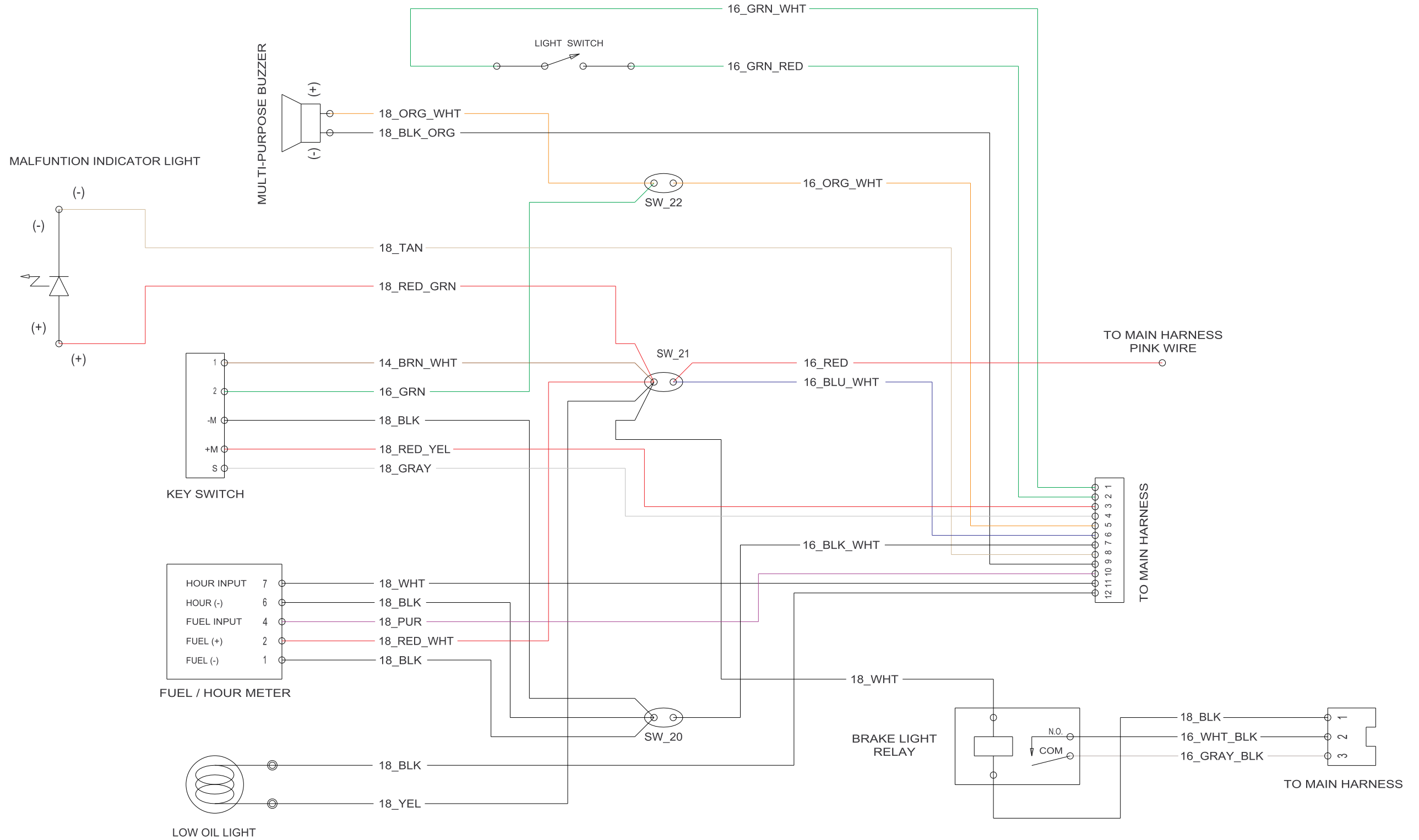

*(Page intentionally left blank.)*

# GASOLINE: FNR HARNESS

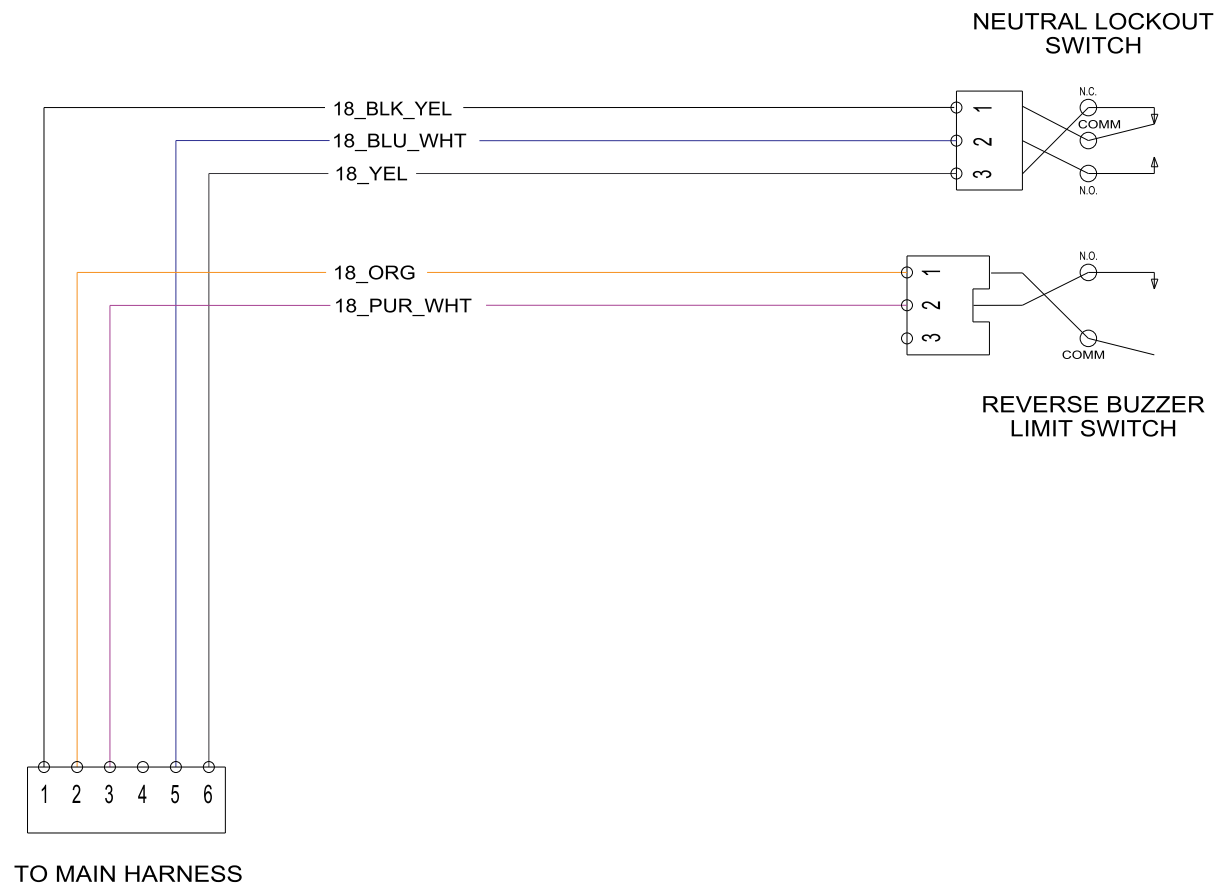

*(Page intentionally left blank.)*



**A**

- accelerator
  - cable
    - installation ..... 14-8
    - removal ..... 14-7
  - pedal (gas)
    - height adjustment ..... 5-10
    - installation ..... 5-6
    - removal ..... 5-5
  - pedal limit switch (pedal-start)
    - testing ..... 11-15
  - rod
    - installation and adjustment ..... 14-3
    - removal ..... 14-2
- accelerator pedal limit switch
  - installation ..... 12-30
  - removal ..... 12-30
- air cleaner
  - installation ..... 14-12
  - removal ..... 14-12
- air intake system ..... 14-11
- armature
  - see starter/generator ..... 12-1
- axle shaft, rear
  - installation ..... 17-7
  - removal ..... 17-6

**B**

- battery
  - installation ..... 12-44
  - storage ..... 12-45
  - testing ..... 11-8
  - testing under load ..... 11-8, 11-28
  - voltage test ..... 11-8
- bed, tilt
  - see tilt bed ..... 4-12
- belt tension tool modification ..... 12-18
- belt, drive
  - see drive belt ..... 16-3
- body, front
  - repair ..... 4-2
- body, rear
  - repair ..... 4-2
- brake, park
  - see park brake ..... 5-4
- brakes
  - adjustment ..... 6-7
  - cable
    - installation ..... 6-16
    - removal ..... 6-16
  - cleaning assembly ..... 6-3
  - cluster
    - installation ..... 6-14
    - removal ..... 6-14
  - pedal
    - height adjustment (gas) ..... 5-7

- installation ..... 5-1
  - removal ..... 5-1
- shoe
  - installation ..... 6-6
  - removal ..... 6-1
- bumper
  - installation ..... 4-8
  - removal ..... 4-8

**C**

- canopy ..... 19-2
  - cleaning ..... 19-1
  - installation ..... 19-4
  - removal ..... 19-3
- canopy frame
  - installation ..... 19-4
  - removal ..... 19-4
- carburetor
  - closed throttle or idle adjustment ..... 14-10
- CAUTION
  - definition of ..... 1-1
- cleaning
  - brake assembly ..... 6-3
  - vehicle body ..... 4-1
- clutch (torque converter) troubleshooting ..... 16-1
- clutch, drive
  - see drive clutch ..... 16-4
- clutch, driven
  - see driven clutch ..... 16-12
- coffee door
  - installation ..... 19-7
  - removal ..... 19-7
- column, steering
  - see steering column ..... 7-3
- commutator
  - see starter/generator ..... 12-1
- connector, 4-pin
  - see test procedures ..... 11-40
- cowl
  - installation
    - gas ..... 4-4
  - removal
    - gas ..... 4-4

**D**

- DANGER
  - definition of ..... 1-1
- dash panel
  - removal ..... 4-10
- differential
  - see transaxle ..... 17-9
- drive belt
  - inspection ..... 16-3
  - installation ..... 16-3
  - removal ..... 16-3

## INDEX

---

drive clutch	
assembly .....	16-10
cleaning and inspection .....	16-6, 16-9
disassembly .....	16-7
installation .....	16-11
removal .....	16-5
drive unit	
see transaxle .....	17-9
driven clutch	
assembly .....	16-16
disassembly .....	16-13
inspection .....	16-16
installation .....	16-19
removal .....	16-13

## E

electric bed lift	
installation .....	4-19
removal .....	4-19
electrical system	
gasoline vehicle .....	11-5
engine .....	13-1
installation .....	13-5
removal .....	13-2
RPM adjustment.....	14-2, 14-10

## F

fender, tailskirt, rear	
removal .....	4-16
floor mat	
installation .....	4-20
removal .....	4-20
forward/neutral/reverse control	
handle (lever).....	17-1
forward/reverse	
cable	
adjustment.....	17-14
installation .....	17-14
removal .....	17-13
fuel	
relieving pressure .....	14-13
fuel filter	
installation .....	14-24
removal .....	14-24
fuel gauge/hour meter .....	12-35
fuel gauge circuit	
testing .....	11-35
fuel level sending unit .....	12-36
fuel level sending unit testing .....	11-33
hour meter circuit	
testing .....	11-36
installation .....	12-36
removal .....	12-36
fuel gauge/hour meter (gasoline vehicles)	
operation .....	12-35

fuel level sending unit .....	12-36
fuel level sending unit testing.....	11-33
fuel line .....	14-13
installation .....	14-15
removal .....	14-14
fuel pump module .....	14-17
installation .....	14-19
removal .....	14-18
fuel pump testing .....	11-30
fuel tank .....	14-20
disposal .....	14-22
installation .....	14-23
removal .....	14-21
storage .....	14-22
fuse	
installation .....	12-29
removal .....	12-28
fuses	
testing .....	11-10

## G

governor	
governor system.....	17-2
governor cable	
installation and adjustment.....	14-6
removal .....	14-5
grille	
installation .....	4-6
removal .....	4-5
ground cable	
testing .....	11-12
Guardian	
connector, 4-pin	
see test procedures.....	11-40

## H

headlight switch	
installation .....	12-38
removal .....	12-38
headlights	
see also lighting circuit.....	11-38
testing .....	11-38
hubs	
hub, rear	
installation .....	17-4
removal .....	17-4

## I

ignition	
testing spark .....	11-26
inspection	
drive clutch .....	16-6
drive clutch parts.....	16-9

- driven clutch ..... 16-16  
front wheel free play ..... 7-21  
shock absorber ..... 9-1  
starter/generator  
  armature ..... 12-7  
  bearing ..... 12-6–12-7  
  brush spring ..... 12-3  
  brushes ..... 12-3  
  commutator ..... 12-8  
  field coils ..... 12-10  
instrument panel  
  installation ..... 4-9  
  removal ..... 4-9
- ## K
- key switch  
  installation ..... 12-21  
  removal ..... 12-20  
kill circuit, engine (pedal-start)  
  testing ..... 11-20  
kill limit switch  
  installation ..... 12-31  
  removal ..... 12-31
- ## L
- leaf spring  
  see suspension, front and suspension, rear ..... 9-2  
light switch  
  testing ..... 11-37  
low oil warning light  
  installation ..... 12-34  
  removal ..... 12-34  
  testing ..... 11-28  
lubrication  
  front suspension ..... 7-15
- ## M
- maintenance/operate switch  
  general information ..... 17-1  
maintenance/operate switch (pedal-start)  
  testing ..... 11-18  
malfunction indicator light  
  installation ..... 12-35  
  removal ..... 12-35  
  testing ..... 11-28  
muffler  
  installation ..... 15-2  
  removal ..... 15-1  
  see also exhaust system ..... 15-1
- ## N
- neutral lockout  
  limit switch  
    installation ..... 12-24  
    removal ..... 12-23  
neutral lockout limit switch (pedal-start)  
  testing ..... 11-19
- ## O
- oil seal  
  installation ..... 17-8  
  removal ..... 17-7  
oxygen sensor ..... 12-46  
  installation ..... 12-46  
  removal ..... 12-46
- ## P
- park brake  
  adjustment (gas) ..... 5-9  
  installation ..... 5-4  
  removal ..... 5-4  
pedal group adjustment  
  gasoline ..... 5-7  
powertrain  
  removal ..... 17-9
- ## R
- rack and pinion  
  assembly ..... 7-10  
  disassembly ..... 7-8  
  installation ..... 7-13  
  removal ..... 7-7  
rear suspension  
  see suspension, rear ..... 9-1  
rear wheel bearing  
  see wheel bearing ..... 17-7  
refreshment unit ..... 19-1  
  cleaning ..... 19-1  
  compartments ..... 19-1  
  general information ..... 19-1  
reverse buzzer  
  installation ..... 12-32  
  limit switch  
    installation ..... 12-33  
    removal ..... 12-33  
    testing ..... 11-27  
  removal ..... 12-32  
  testing ..... 11-27  
RPM adjustment ..... 14-2, 14-10
- ## S
- safety ..... 1-1  
service tools  
  torque converter kit ..... 16-1

## INDEX

- transaxle..... 17-3
  - shock absorber
    - see suspension, front and suspension, rear ..... 9-1
  - shock absorber, front
    - installation ..... 7-20
    - removal ..... 7-20
  - slide door
    - horizontal
      - installation ..... 19-6
      - removal ..... 19-6
    - vertical
      - installation ..... 19-6
      - removal ..... 19-6
  - solenoid
    - installation ..... 12-27
    - removal ..... 12-26
  - solenoid (pedal-start)
    - testing ..... 11-16
  - specifications, vehicle ..... 2-1
  - starter/generator
    - armature
      - ground test ..... 12-9
      - inspection ..... 12-7
      - servicing ..... 12-5
    - assembly ..... 12-4, 12-10
    - bearing
      - cleaning ..... 12-6–12-7
      - inspection ..... 12-6–12-7
      - removal ..... 12-7
    - belt tension adjustment ..... 12-15
    - belt tension inspection ..... 12-14
    - brush spring
      - inspection ..... 12-3
      - replacement ..... 12-3
    - brushes ..... 12-2
      - inspection ..... 12-3
      - replacement ..... 12-3
    - commutator ..... 12-5
      - armature replacement ..... 12-8
      - cleaning ..... 12-8
      - inspection ..... 12-8
    - disassembly ..... 12-2, 12-5
    - field coil
      - inspection ..... 12-10
      - removal ..... 12-7
    - installation ..... 12-13
    - removal ..... 12-1
    - rework ..... 12-10
    - testing ..... 11-21–11-22
  - steering
    - adjustment ..... 7-6
    - rack and pinion
      - assembly ..... 7-10
      - disassembly ..... 7-8
      - installation ..... 7-13
      - removal ..... 7-7
  - steering column
    - assembly ..... 7-4
    - disassembly ..... 7-4
    - installation ..... 7-5
    - removal ..... 7-4
  - steering wheel
    - installation ..... 7-2
    - removal ..... 7-1
  - suspension, front
    - camber adjustment ..... 7-15
    - components ..... 7-17
      - delta a-plate, installation ..... 7-20
      - delta a-plate, removal ..... 7-20
      - kingpin and steering spindle, installation ..... 7-20
      - kingpin and steering spindle, removal ..... 7-17
      - leaf spring, installation ..... 7-17
      - leaf spring, removal ..... 7-17
    - shock absorber, installation ..... 7-20
    - shock absorber, removal ..... 7-20
    - wheel bearings and hub, inspection ..... 7-21
    - wheel bearings and hub, installation ..... 7-22
    - wheel bearings and hub, removal ..... 7-21
    - lubrication ..... 7-15
    - toe-in adjustment ..... 7-16
    - wheel alignment ..... 7-15
  - suspension, rear
    - leaf spring
      - installation ..... 9-3
      - removal ..... 9-2
    - shock absorber
      - inspection and removal ..... 9-1
      - installation ..... 9-1
- ## T
- test procedures, gasoline vehicle
    - 4-pin connector ..... 11-40
    - accelerator pedal limit switch (pedal-start) ..... 11-15
    - battery ..... 11-8
    - battery load test ..... 11-28
    - fuel gauge ..... 11-35
    - fuel level sending unit ..... 11-33
    - fuel pump ..... 11-30
    - fuses ..... 11-10
    - ground cables ..... 11-12
    - headlight socket
      - voltage at ..... 11-38
    - hour meter ..... 11-36
    - ignition spark ..... 11-26
    - key switch
      - engine kill circuit (pedal-start) ..... 11-14
      - starter circuit (pedal-start) ..... 11-13
    - kill limit switch (pedal-start) ..... 11-20
    - light switch ..... 11-37
    - low oil warning light ..... 11-28
    - maintenance/operate switch (pedal-start) ..... 11-18
    - malfunction indicator light ..... 11-28
    - neutral lockout limit switch (pedal-start) ..... 11-19
    - reverse buzzer ..... 11-27
    - reverse buzzer limit switch ..... 11-27
    - solenoid (pedal-start) ..... 11-16

starter/generator.....	11-21–11-22	installation .....	17-7
voltage limiter.....	11-39	removal .....	17-7
voltage regulator .....	11-25	wiring diagrams .....	20-1
test procedures, index of		engine wire harness .....	20-12
gasoline vehicle .....	11-6	key-start gasoline vehicle.....	20-7
testing		pedal-start gasoline vehicle.....	20-2
armature ground test (starter/generator) .....	12-9		
throttle body .....	14-1		
tie rod and drag link			
installation .....	7-14		
removal .....	7-14		
tilt bed			
installation .....	4-12		
removal .....	4-12		
tire			
installation .....	8-3		
pressure .....	8-1		
removal .....	8-2		
repair.....	8-2		
tools			
see service tools .....	17-3		
torque converter			
troubleshooting .....	16-1		
transaxle			
installation .....	17-13		
lubrication .....	17-2		
removal .....	17-9		
service.....	17-2		
trash drawer			
installation .....	19-6		
removal .....	19-5		
troubleshooting			
torque converter .....	16-1		
troubleshooting guide			
gasoline vehicle .....	11-2		

## V

Visage	
connector, 4-pin	
see test procedures.....	11-40
voltage limiter	
testing .....	11-39
voltage regulator	
installation .....	12-19
removal .....	12-19
testing .....	11-25

## W

WARNING	
definition of .....	1-1
wheel	
installation .....	8-1
removal .....	8-1
see also tire .....	8-3
wheel bearing	







**Club Car, LLC**  
P.O. Box 204658  
Augusta, GA 30917-4658  
USA

**Web** [www.clubcar.com](http://www.clubcar.com)  
**Phone** 1.706.863.3000  
1.800.ClubCar  
**Int'l** +1 706.863.3000  
**Fax** 1.706.863.5808