

**Club Car**

®

**2004  
MAINTENANCE  
SERVICE  
SUPPLEMENT**

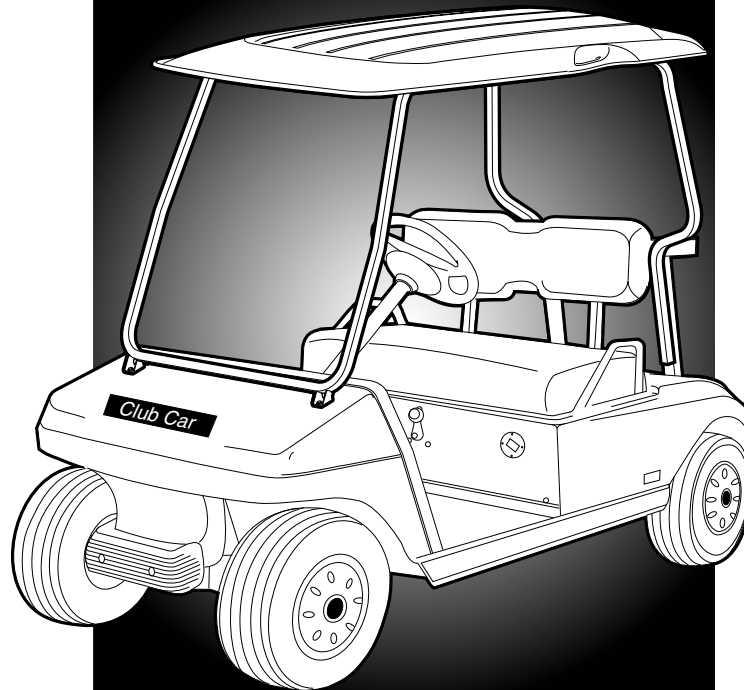

**V-GLIDE 36-VOLT  
ELECTRIC VEHICLES**

MANUAL NUMBER 102397604  
EDITION CODE 1203A00000



## FOREWORD

---

Club Car vehicles are designed and built to provide the ultimate in performance efficiency; however, proper maintenance and repair are essential for achieving maximum service life and continued safe and reliable operation.

This supplement provides detailed information for the maintenance and repair of V-Glide 36-Volt electric vehicles and should be used in conjunction with the 2004 DS Golf Car Maintenance and Service Manual (CCI P/N 102397601).

If you do not have a 2004 DS Golf Car Maintenance and Service Manual, you may order one from your local Club Car representative.

This supplement, in addition to the 2004 DS Golf Car Maintenance and Service Manual, should be thoroughly reviewed prior to servicing the vehicle. The procedures provided must be properly implemented, and the DANGER, WARNING and CAUTION statements must be heeded.

This supplement was written for the trained technician who already has knowledge and skills in electrical and mechanical repair. If the technician does not have such knowledge and skills, attempted service or repairs to the vehicle may render the vehicle unsafe. For this reason, Club Car advises that all repairs and/or service be performed by an authorized Club Car distributor/dealer representative or by a Club Car factory-trained technician.

It is the policy of Club Car, Inc. to assist its distributors and dealers in continually updating their service knowledge and facilities so they can provide prompt and efficient service for vehicle owners. Regional technical representatives, vehicle service seminars, periodic service bulletins, maintenance and service manuals, and other service publications also represent Club Car's continuing commitment to customer support.

This supplement, used in conjunction with the 2004 DS Golf Car Maintenance and Service Manual, covers all aspects of typical vehicle service; however, unique situations do sometimes occur when servicing a vehicle. If it appears that a service question is not answered in this supplement, you may write to us at: Club Car, Inc., P.O. Box 204658; Augusta, Georgia 30917-4658, USA, Attention: Technical Services, or contact a Club Car Technical Service Representative at (706) 863-3000, ext. 3580.

This supplement does not contain maintenance and service procedures for the battery charger. Contact your local Club Car representative for information on how to obtain the appropriate battery charger maintenance and service manual.

Copyright © 2003 Club Car, Inc.  
Club Car and *ArmorFlex* are registered  
trademarks of Club Car, Inc.  
This manual effective July 28, 2003.

## **WARNING**

- **Read Section 1 – Safety in the DS Golf Car Maintenance and Service Manual before attempting any service on the vehicle.**
- **Before servicing vehicle, read complete section(s) and any referenced information that may be relevant to the service or repair to be performed.**

**NOTE:** *This manual represents the most current information at the time of publication. Club Car, Inc. is continually working to further improve its vehicles and other products. These improvements may affect servicing procedures. Any modification and/or significant change in specifications or procedures will be forwarded to all Club Car distributors and dealers and will, when applicable, appear in future editions of this manual.*

*Club Car, Inc. reserves the right to change specifications and designs at any time without notice and without the obligation of making changes to units previously sold.*

*There are no warranties expressed or implied in this supplement. See the limited warranty found in the vehicle owner's manual or write to: Club Car, Inc., P.O. Box 204658, Augusta, GA 30917-4658, USA, Attention: Warranty Administration.*

# CONTENTS

---

## SECTION 10 – PERIODIC MAINTENANCE

---

General Warning .....	10-1
General Information .....	10-2
Periodic Service Schedule .....	10-2
Periodic Lubrication Schedule .....	10-4

## SECTION 11 – ELECTRICAL SYSTEM AND TESTING

---

General Information .....	11-1
Electrical Circuits .....	11-1
Control Circuit .....	11-1
Power Circuit .....	11-2
Charge Circuit .....	11-2
Wiring Diagram .....	11-4
Troubleshooting Guide .....	11-5
Test Procedures .....	11-7
Index of Test Procedures .....	11-7

## SECTION 12 – ELECTRICAL COMPONENTS

---

Key Switch .....	12-1
Forward/Reverse Anti-Arcing Limit Switch .....	12-3
Accelerator Pedal Limit Switch .....	12-3
Reverse Buzzer .....	12-4
Solenoid .....	12-5
Resistors .....	12-6
Wiper Switch .....	12-8
Forward/Reverse Switch .....	12-14
Charger Receptacle .....	12-15
Receptacle Fuse Link .....	12-17

## SECTION 13 – BATTERIES

---

General Information .....	13-1
Common Misconceptions About Batteries .....	13-3
Battery Replacement .....	13-3

Battery Care .....	13-4
Preventive Maintenance .....	13-4
Self-Discharge .....	13-5
Electrolyte Level .....	13-5
Vibration Damage .....	13-6
Battery Charging .....	13-6
Charger Does Not Shut Off Automatically .....	13-7
Deep-Discharge .....	13-7
Early Excessive Discharging .....	13-7
Incoming AC Service .....	13-7
Fleet Rotation .....	13-7
Numbering Vehicles and Chargers .....	13-7
Battery Troubleshooting Chart .....	13-8
Battery Testing .....	13-9
Battery Charger Test .....	13-9
On-Charge Voltage Test .....	13-9
Hydrometer Test .....	13-9
Discharge Test .....	13-11
Battery Troubleshooting Examples .....	13-13
Battery Storage .....	13-14
Charging a Battery Pack that has Low Voltage .....	13-14

## **SECTION 14 – BATTERY CHARGER**

---

Refer to the appropriate battery charger maintenance and service manual.

## **SECTION 15 – MOTOR**

---

General Information .....	15-1
External Motor Testing .....	15-1
Motor .....	15-3
Motor Component Testing and Inspection .....	15-5
Armature .....	15-5
Field Windings Inspection .....	15-6
Motor Components .....	15-7
Bearing Inspection .....	15-7
Bearing Removal .....	15-9
Bearing Installation .....	15-9
Reconditioning the Motor .....	15-9
Motor Assembly .....	15-10
Motor Installation .....	15-11

## **SECTION 16A – TRANSAXLE (TYPE G)**

---

Transaxle Identification .....	16a-1
Lubrication .....	16a-1
Axle Bearing and Shaft .....	16a-1
Axle Shaft .....	16a-1
Axle Bearing .....	16a-4
Transaxle .....	16a-4
Transaxle Removal .....	16a-5
Transaxle Disassembly, Inspection, and Assembly .....	16a-7
Transaxle Disassembly and Inspection .....	16a-7
Transaxle Assembly .....	16a-9
Transaxle Installation .....	16a-10

## **SECTION 16B – TRANSAXLE (TYPE K)**

---

Transaxle Identification .....	16b-1
Lubrication .....	16b-1
Axle Bearing and Shaft .....	16b-1
Axle Shaft .....	16b-1
Axle Bearing .....	16b-4
Transaxle .....	16b-5
Transaxle Removal .....	16b-5
Transaxle Disassembly, Inspection, and Assembly .....	16b-8
Transaxle Disassembly and Inspection .....	16b-8
Transaxle Assembly .....	16b-10
Shimming the Transaxle .....	16b-12
Transaxle Installation .....	16b-13

## **SECTION i – INDEX**

---





# SECTION 10 – PERIODIC MAINTENANCE

---

## GENERAL WARNING

---

The following safety statements must be heeded whenever the vehicle is being operated, repaired, or serviced. Service technicians should become familiar with these general safety statements, which can be found throughout this manual. Also, other specific safety statements appear throughout this manual and on the vehicle.

### **⚠ DANGER**

- **Battery – Explosive gases! Do not smoke. Keep sparks and flames away from the vehicle and service area. Ventilate when charging or operating vehicle in an enclosed space. Wear a full face shield and rubber gloves when working on or near batteries.**
- **Battery – Poison! Contains acid! Causes severe burns. Avoid contact with skin, eyes, or clothing. Antidotes:**
  - **External: Flush with water. Call a physician immediately.**
  - **Internal: Drink large quantities of milk or water. Follow with milk of magnesia or vegetable oil. Call a physician immediately.**
  - **Eyes: Flush with water for 15 minutes. Call a physician immediately.**

### **⚠ WARNING**

- **Follow the procedures exactly as stated in this manual, and heed all DANGER, WARNING, and CAUTION statements in this manual as well as those on the vehicle and battery charger.**
- **Only trained technicians should repair or service the vehicle or battery charger. Anyone doing even simple repairs or service should have knowledge and experience in electrical and mechanical repair.**
- **Prior to servicing the vehicle or leaving the vehicle unattended, turn the key switch OFF, remove the key, and place the Forward/Reverse handle in the NEUTRAL position. Chock the wheels when servicing the vehicle.**
- **To avoid unintentionally starting the vehicle, disconnect the batteries as shown (Figure 10-1, Page 10-2).**
- **Wear safety glasses or approved eye protection when servicing the vehicle or battery charger. Wear a full face shield and rubber gloves when working on or near batteries.**
- **Do not wear loose clothing or jewelry such as rings, watches, chains, etc., when servicing the vehicle or battery charger.**
- **Moving parts! Do not attempt to service the vehicle while it is running.**
- **Hot! Do not attempt to service hot motor or resistors. Failure to heed this warning could result in severe burns.**
- **Use insulated tools when working near batteries or electrical connections. Use extreme caution to avoid shorting of components or wiring.**
- **Check the vehicle owner's manual for proper location of all vehicle safety and operation decals and make sure they are in place and are easy to read.**

WARNING CONTINUED ON NEXT PAGE...

**⚠ WARNING**

- Any modification or change to the vehicle that affects the stability or handling of the vehicle, or increases maximum vehicle speed beyond factory specifications, could result in severe personal injury or death.
- Lift only one end of the vehicle at a time. Use a suitable lifting device (chain hoist or hydraulic floor jack) with 1000 lb. (454 kg) minimum lifting capacity. Do not use lifting device to hold vehicle in raised position. Use approved jack stands of proper weight capacity to support the vehicle and chock the wheels that remain on the floor. When not performing a test or service procedure that requires movement of the wheels, lock the brakes.
- If wires are removed or replaced, make sure wiring and wire harness are properly routed and secured. Failure to properly route and secure wiring could result in vehicle malfunction, property damage, personal injury, or death.
- Improper use of the vehicle or failure to properly maintain it could result in decreased vehicle performance, severe personal injury, or death.
- Do not leave children unattended on vehicle.

**GENERAL INFORMATION**

See General Warning on page 10-1.

To ensure trouble-free vehicle performance, it is very important to follow an established preventive maintenance program. Regular and consistent vehicle maintenance can prevent vehicle downtime and expensive repairs that can result from neglect. Any vehicle not functioning correctly should be removed from use until it is properly repaired. This will prevent further damage to the vehicle and avoid the possibility of injury due to unsafe conditions.

Contact your local Club Car distributor/dealer to perform all repairs and semiannual and annual periodic service.

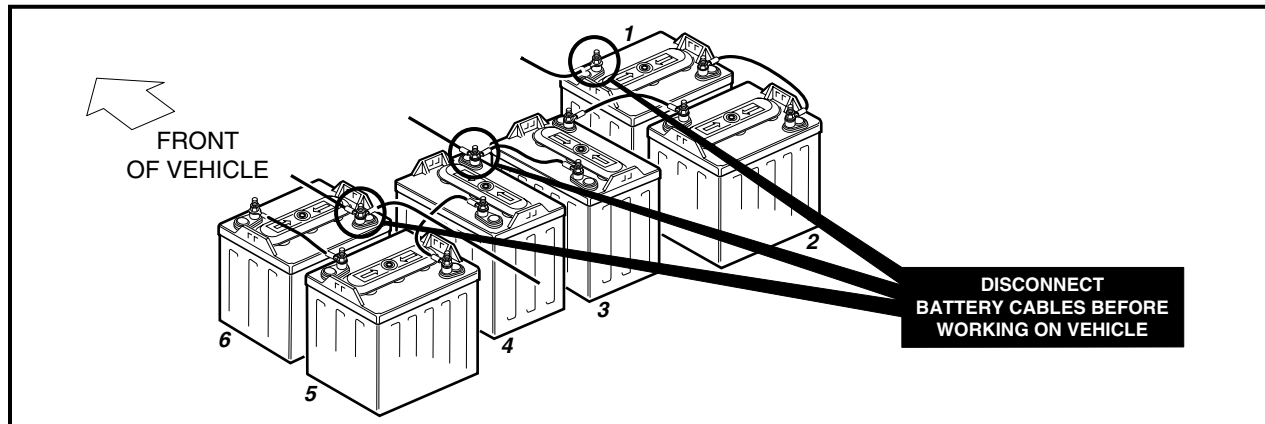

Figure 10-1 V-Glide Battery Configuration

**PERIODIC SERVICE SCHEDULE****⚠ WARNING**

- Service, repairs, and adjustments must be made per instructions in the DS Golf Car

**Maintenance and Service Manual and this supplement.**

**NOTE:** *If the vehicle is constantly subjected to heavy use or severe operating conditions, the preventive maintenance procedures should be performed more often than recommended in the periodic service and lubrication schedules.*

*Both the Periodic Service Schedule and the Periodic Lubrication Schedule must be followed to keep the vehicle in optimum operating condition.*

PERIODIC SERVICE SCHEDULE		
REGULAR INTERVAL	SERVICE	
Daily service by owner	Batteries	Charge batteries after each use.
Weekly service by owner	Batteries	Check electrolyte level. Add water if necessary. <b>See Section 13 – Batteries.</b>
Monthly service by owner or trained technician	Batteries	Wash battery tops and clean terminals with baking soda/water solution.
	Tires	Check air pressure and adjust if necessary. <b>See Section 2 – Specifications in the DS Maintenance and Service Manual.</b>
	Wiper switch	Check for cracks or other damage; make sure switch is securely fastened to frame. Check movable contact for correct operation.
	General vehicle	Wash battery compartment and underside of vehicle.
Semiannual service by trained technician only (every 50 hours of operation or 100 rounds of golf)	Brake system	Check brake shoes; replace if necessary. <b>See Section 6 – Wheel Brake Assemblies in the DS Maintenance and Service Manual.</b>
		Lubricate brake slide. <b>See Periodic Lubrication Schedule on page 10-4. See also Section 6 – Wheel Brake Assemblies in the DS Maintenance and Service Manual.</b>
		Check brake cables for damage; replace if necessary.
	Electrical wiring and connections	Check for tightness and damage.
	Forward/Reverse switch	Check condition of contacts and wire connections; make sure connections are tight.
	Front wheel alignment and camber	Check and adjust as required. <b>See Section 7 – Steering and Front Suspension in the DS Maintenance and Service Manual.</b>
Annual service by trained technician only (every 100 hours of operation or 200 rounds of golf)	Batteries	If batteries are not performing as expected, see Section 13 – Batteries.

** WARNING**

- If any problems are found during scheduled inspection or service, do not operate the vehicle until repairs are made. Failure to make necessary repairs could result in fire, property

damage, severe personal injury, or death.

## PERIODIC LUBRICATION SCHEDULE

PERIODIC LUBRICATION SCHEDULE			
REGULAR INTERVAL	SERVICE	LUBRICATION POINTS	RECOMMENDED LUBRICANT
Semiannually by owner or trained technician (every 50 hours of operation or 100 rounds of golf)	Brake pedal shaft bearings	1	Dry Moly Lube (CCI P/N 1012151)
	Brake linkage and pivots	2	Dry Moly Lube (CCI P/N 1012151)
	Accelerator push rod pivots and mounts	3	Dry Moly Lube (CCI P/N 1012151)
	Forward/Reverse switch contacts and charger receptacle	4	WD 40
	Brake slides	5	Dry Moly Lube (CCI P/N 1012151)
	Front suspension (5 fittings)	6	Chassis Lube (EP NLGI Grade 2)
Annually by trained technician only (every 100 hours of operation or 200 rounds of golf)	Check/fill transaxle to plug level	7	22 oz. (0.67 liter) SAE 30 WT. API, class SE, SF, or SG oil (or higher)

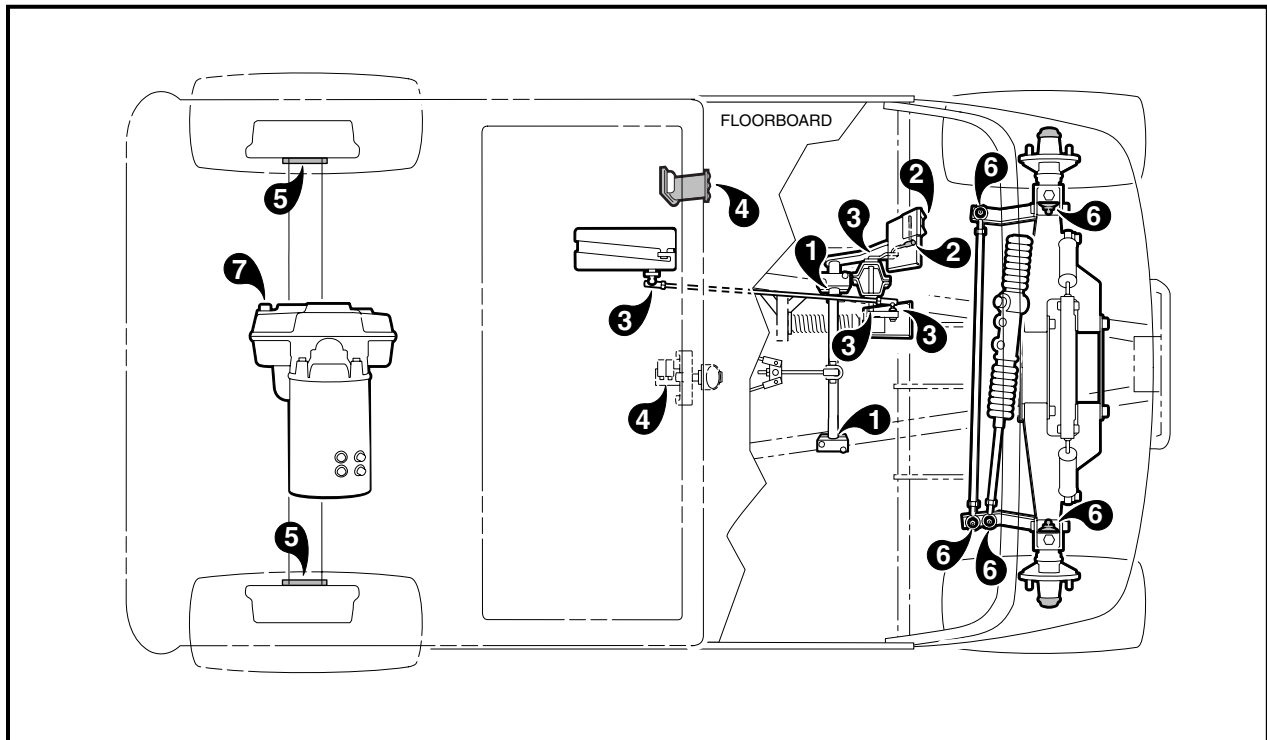

Figure 10-2 V-Glide 36-Volt Vehicle Lubrication Points

# SECTION 11 – ELECTRICAL SYSTEM AND TESTING

---

## **⚠ DANGER**

- See General Warning, Section 10, Page 10-1.

## **⚠ WARNING**

- See General Warning, Section 10, Page 10-1.

## GENERAL INFORMATION

---

To properly service and maintain the V-Glide 36-volt vehicle, it is necessary to understand the electrical circuitry and the functions of all the electrical components (**Figure 11-2, Page 11-4**). On the V-Glide 36-volt vehicle, there are three separate circuits: 1) the control circuit, 2) the power circuit, and 3) the charge circuit. A reverse buzzer is also included on every vehicle.

## ELECTRICAL CIRCUITS

---

There are three separate circuits which make up the electrical system of the V-Glide 36-volt vehicle:

- Control circuit
- Power circuit
- Charge circuit

A reverse buzzer is also included on every vehicle.

### CONTROL CIRCUIT

The control circuit consists of the following:

- Key switch
- Forward/Reverse anti-arcing limit switch
- Accelerator pedal limit switch
- Solenoid
- Connecting wires

The key switch has two positions, ON and OFF, and is used to disable (open) the control circuit when the vehicle is not in use. With the key in the OFF position, the vehicle will not operate.

The Forward/Reverse anti-arcing limit switch prevents arcing on the contacts of the Forward/Reverse switch. When the vehicle is in NEUTRAL, the limit switch is open. The Forward/Reverse anti-arcing limit switch closes only after full contact has been made on the Forward/Reverse switch. As the Forward/Reverse switch is disengaged, the Forward/Reverse anti-arcing limit switch opens the power circuit by opening the control circuit before the contacts are separated. By using the Forward/Reverse anti-arcing limit switch to control power to the Forward/Reverse switch, arcing is prevented on the contacts of the Forward/Reverse switch.

**Control Circuit, Continued:**

As the accelerator pedal is pressed, the lever of the accelerator pedal limit switch is released by the V-Glide wiper arm, closing that portion of the control circuit. When the accelerator pedal is fully upright, the V-Glide wiper arm presses the accelerator pedal limit switch lever and keeps that portion of the control circuit open.

When the accelerator pedal is pressed (which closes the accelerator pedal limit switch) and the Forward/Reverse handle is in FORWARD or REVERSE (which closes Forward/Reverse anti-arcing limit switch), and key switch is in the ON position, the control circuit is complete. The solenoid coil (enclosed in the solenoid) will then be activated and the solenoid power contacts will close, allowing power to reach the V-Glide wiper switch.

The reverse buzzer is a warning device that is activated when the Forward/Reverse handle is placed in REVERSE. The reverse buzzer will sound continuously until the vehicle is shifted to NEUTRAL or FORWARD.

**POWER CIRCUIT**

The power circuit consists of the following:

- V-Glide wiper switch contacts
- Resistors
- Forward/Reverse switch
- Solenoid power contacts
- Motor
- Batteries
- All connecting wires

The motor and batteries are discussed in separate sections in this manual. **See Section 15 – Motor. See also Section 13 – Batteries.**

When the control circuit is closed, the vehicle will start in first speed. As the accelerator pedal is pressed, the brush on the wiper switch arm moves across the contacts until the last contact is reached and full speed is attained. The V-Glide wiper switch brush and contacts conduct the motor current through or around each resistor, thereby controlling the speed (**Figure 11-1, Page 11-3**).

The Forward/Reverse switch changes the direction of vehicle movement by changing the direction of electrical current through the motor, and consequently, the direction the motor turns. By limiting maximum voltage available in REVERSE to one-half that available in FORWARD, maximum vehicle speed in REVERSE is limited to one-half the maximum vehicle speed in FORWARD.

**CHARGE CIRCUIT**

The charge circuit consists of the following:

- Battery charger
- Charger plug
- Charger receptacle
- Onboard fuse link
- Batteries

The batteries are discussed in a separate section in this manual. **See Section 13 – Batteries.** The battery charger is discussed in the battery charger maintenance and service manual. **See the appropriate battery charger maintenance and service manual.**

The charger plug and receptacle connection is a critical link between the charger and the vehicle battery circuit. The contacts in the receptacle must grip the plug blades well enough to create enough pressure or drag for an adequate electrical connection. If little or no drag is felt, the receptacle or plug must be replaced. If either the plug or receptacle is damaged or feels hot when charging, one or both must be replaced. **See Charger Receptacle Inspection, Section 12, Page 12-16.**

The onboard receptacle fuse link provides additional protection for the vehicle charging circuit. The fuse is rated for use with a Club Car Accu-Power Charger only. If it is blown, the cause should be determined before the fuse is replaced. Batteries in a vehicle with a blown fuse will not accept a charge. **See Receptacle Fuse Link, Section 12, Page 12-17.**

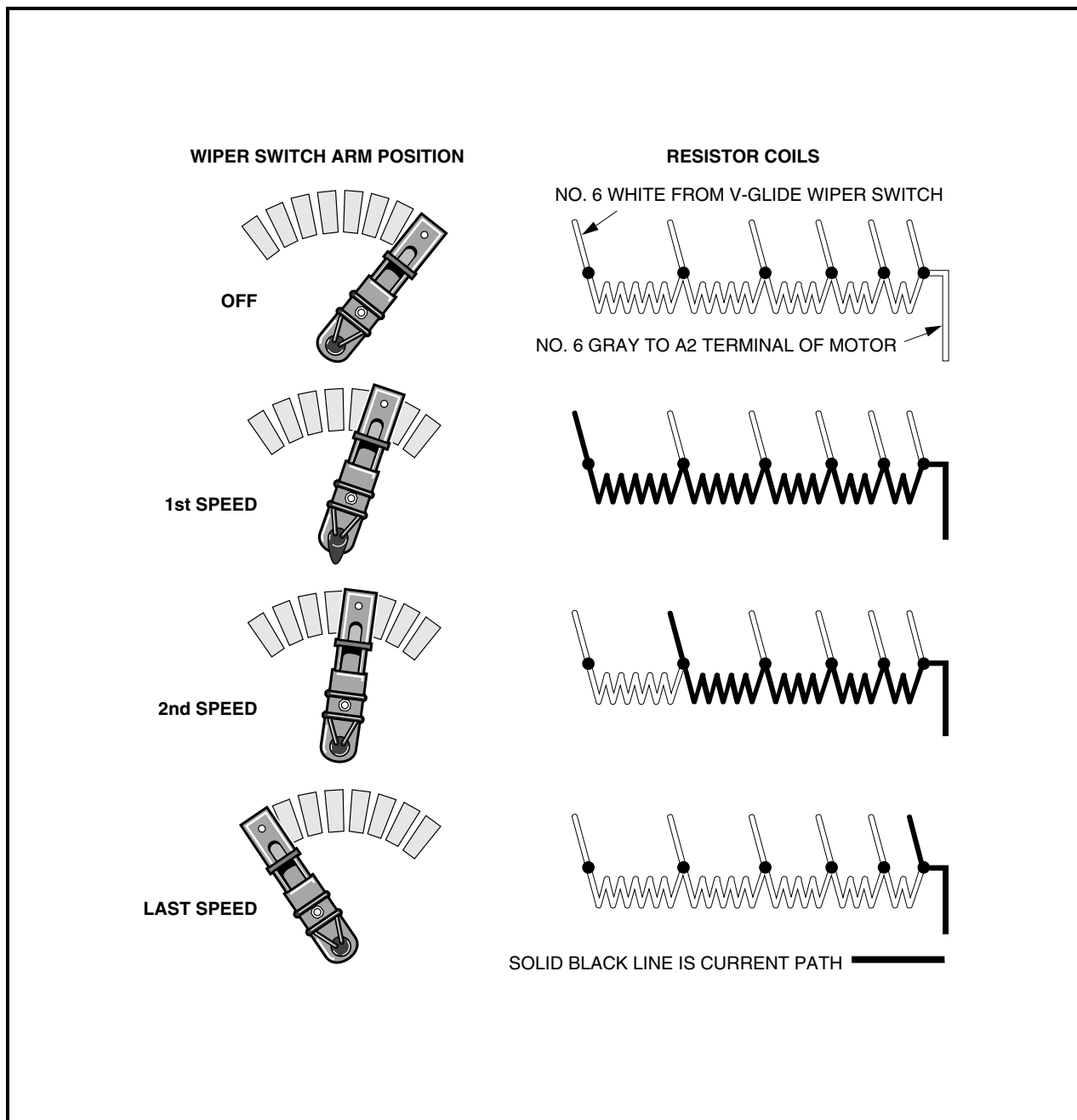

Figure 11-1 Speed Controller

WIRING DIAGRAM

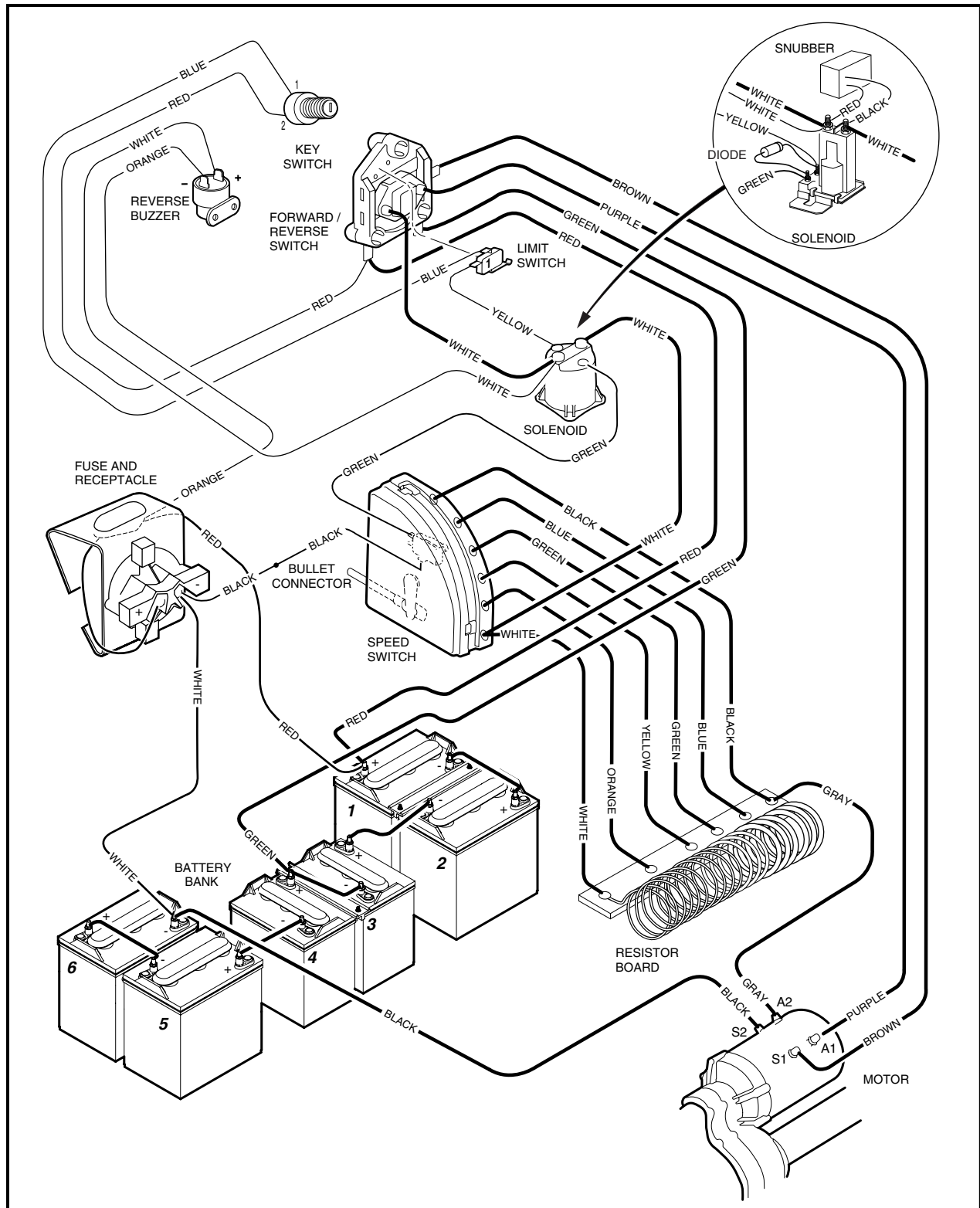

Figure 11-2 Wiring Diagram



## TROUBLESHOOTING GUIDE

TROUBLESHOOTING GUIDE		
SYMPTOM	POSSIBLE CAUSES	CORRECTIVE ACTION
<b>Vehicle will not operate – no solenoid click</b>	Battery connections	Test Procedure 1 – Batteries/Voltage Check on page 11-8
	Batteries discharged	Test Procedure 1 – Batteries/Voltage Check on page 11-8
	Loose wiring at key switch	Test Procedure 2 – Key Switch on page 11-8
	Failed key switch	Test Procedure 2 – Key Switch on page 11-8
	Loose wiring at Forward/Reverse anti-arcing limit switch	Test Procedure 3 – Forward/Reverse Anti-Arcing Limit Switch on page 11-9
	Failed Forward/Reverse anti-arcing limit switch	Test Procedure 3 – Forward/Reverse Anti-Arcing Limit Switch on page 11-9
	Cam is not activating Forward/Reverse anti-arcing limit switch	Test Procedure 3 – Forward/Reverse Anti-Arcing Limit Switch on page 11-9
	Accelerator rod disconnected	See Section 5 – Accelerator and Brake Pedal Group in the DS Golf Car Maintenance and Service Manual
	Loose wiring at accelerator pedal limit switch	Test Procedure 4 – Accelerator Pedal Limit Switch on page 11-9
	Disconnected or improperly connected wires at accelerator pedal limit switch	Test Procedure 4 – Accelerator Pedal Limit Switch on page 11-9
	Failed accelerator pedal limit switch	Test Procedure 4 – Accelerator Pedal Limit Switch on page 11-9
	Loose solenoid switch	Test Procedure 10 – Solenoid Contacts (Power Off) on page 11-15 and Test Procedure 11 – Solenoid Contacts (Power On) on page 11-15
Failed solenoid coil	Test Procedure 5 – Solenoid Activating Coil on page 11-10	
<b>Vehicle will not operate – solenoid clicks</b>	Loose wiring at Forward/Reverse switch	Test Procedure 8 – Forward/Reverse Switch on page 11-12
	Failed Forward/Reverse switch contacts	Test Procedure 10 – Solenoid Contacts (Power Off) on page 11-15
	Failed solenoid contacts	Test Procedure 10 – Solenoid Contacts (Power Off) on page 11-15
	Loose wiring or broken wire connections at V-Glide wiper switch	Test Procedure 12 – V-Glide Wiper Switch on page 11-16
	V-Glide wiper switch brush or contacts are dirty, burned, corroded, shorted, or worn	Test Procedure 12 – V-Glide Wiper Switch on page 11-16 See Section 12 – Electrical Components
	Incorrect wiring at V-Glide wiper switch	See Wiring Diagram on page 11-4
	Loose wiring at motor	Test Procedure 9 – Motor on page 11-14
	Motor circuits open	Test Procedure 9 – Motor on page 11-14, see also Section 15 – Motor
Motor brushes worn	Test Procedure 9 – Motor on page 11-14	
<b>Troubleshooting Guide continued on next page...</b>		

**TROUBLESHOOTING GUIDE**

<b>SYMPTOM</b>	<b>POSSIBLE CAUSES</b>	<b>CORRECTIVE ACTION</b>
<b>Vehicle skips one or more speeds</b>	Loose or broken wire connections at V-Glide wiper switch	Test Procedure 12 – V-Glide Wiper Switch on page 11-16
	V-Glide wiper switch brush contacts are dirty, burned, corroded, shorted, or worn	Test Procedure 7 – Resistors on page 11-11 See Section 12 – Electrical Components
	Incorrect wiring at V-Glide wiper switch	See Wiring Diagram on page 11-4
	Loose or broken resistor	Test Procedure 7 – Resistors on page 11-11
<b>Vehicle runs slowly</b>	Poor wire connections at V-Glide wiper switch	See Wiring Diagram on page 11-4
	V-Glide wiper switch contact points dirty or worn	Test Procedure 12 – V-Glide Wiper Switch on page 11-16
	Loose or corroded battery terminals	Test Procedure 1 – Batteries/Voltage Check on page 11-8 See Section 13 – Batteries
	Incorrect wiring at batteries	See Wiring Diagram on page 11-4
	Failed batteries	See Section 13 – Batteries
	Batteries not fully charged	Refer to the appropriate battery charger maintenance and service manual
	Accelerator rod is improperly adjusted	See Section 5 – Accelerator and Brake Pedal Group in the DS Golf Car Maintenance and Service Manual
	Loose wiring at motor	Test Procedure 9 – Motor on page 11-14
	Worn or misaligned motor brushes	Section 15 – Motor
	Dirty or rough motor commutator	Section 15 – Motor
	Dragging brakes	See Section 5 – Accelerator and Brake Pedal Group in the DS Golf Car Maintenance and Service Manual
Under-inflated or flat tires	See Section 8 – Wheels and Tires in the DS Golf Car Maintenance and Service Manual	
<b>Vehicle operates in first speed when the Forward/Reverse switch is placed in FORWARD or REVERSE with the key switch OFF</b>	Solenoid contacts are welded closed	Test Procedure 10 – Solenoid Contacts (Power Off) on page 11-15
<b>Vehicle operates in first speed when the Forward/Reverse switch is placed in FORWARD or REVERSE with key switch ON</b>	Incorrect wiring at V-Glide wiper switch	See Wiring Diagram on page 11-4
	Accelerator pedal limit switch failed in the closed position	Test Procedure 4 – Accelerator Pedal Limit Switch on page 11-9
	Accelerator rod is bent or improperly adjusted	See Section 5 – Accelerator and Brake Pedal Group in the DS Golf Car Maintenance and Service Manual
	V-Glide wiper switch brush or accelerator pedal is stuck	See Section 5 – Accelerator and Brake Pedal Group in the DS Golf Car Maintenance and Service Manual
	V-Glide wiper switch is improperly adjusted	See Wiper Switch, Section 12 – Electrical Components
<b>Troubleshooting Guide continued on next page...</b>		

<b>TROUBLESHOOTING GUIDE</b>		
<b>SYMPTOM</b>	<b>POSSIBLE CAUSES</b>	<b>CORRECTIVE ACTION</b>
<b>Vehicle will operate in Forward but not in Reverse, or will operate in Reverse but not in Forward</b>	Improper actuation or faulty Forward/Reverse anti-arcing limit switch	Test Procedure 3 – Forward/Reverse Anti-Arcing Limit Switch on page 11-9
	Dirty or corroded Forward/Reverse switch contacts	See Section 12 – Electrical Components
	Incorrect wiring at batteries	See Wiring Diagram on page 11-4
<b>Vehicle not being fully charged</b>	Loose wires at charger receptacle, batteries or Forward/Reverse switch	Refer to the appropriate battery charger maintenance and service manual
	Improper engagement of charger plug and receptacle	Refer to the appropriate battery charger maintenance and service manual
	Blown onboard receptacle fuse	Refer to the appropriate battery charger maintenance and service manual
	Incorrect incoming AC charger voltage	Refer to the appropriate battery charger maintenance and service manual
	Charger output is low	Refer to the appropriate battery charger maintenance and service manual
	Charger cord and plugs	Refer to the appropriate battery charger maintenance and service manual

## TEST PROCEDURES

The entire electrical system can be tested using the following procedures without major disassembly of the vehicle. **See following WARNING.**

### **⚠ WARNING**

- **If wires are removed or replaced, make sure wiring and wire harness is properly routed and secured. Failure to properly route and secure wiring could result in vehicle malfunction, property damage, personal injury, or death.**

## INDEX OF TEST PROCEDURES

1. Batteries/Voltage Check
2. Key Switch
3. Forward/Reverse Anti-Arcing Limit Switch
4. Accelerator Pedal Limit Switch
5. Solenoid Activating Coil
6. Reverse Buzzer
7. Resistors
8. Forward/Reverse Switch
9. Motor
10. Solenoid Contacts (Power Off)
11. Solenoid Contacts (Power On)
12. V-Glide Wiper Switch

## TEST PROCEDURE 1 – BATTERIES/VOLTAGE CHECK

See General Warning, Section 10, Page 10-1.

1. With batteries connected and using a multimeter set to 200 volts DC, place red (+) probe on the positive (+) post of battery no. 1 and the black (–) probe on the negative (–) post of battery no. 6 (**Figure 11-3, Page 11-8**). The multimeter should indicate at least 36 volts with the batteries fully charged. If not, check for loose battery connections or a battery installed in reverse polarity. The batteries are explained in detail in another section. See **Section 13 – Batteries**.

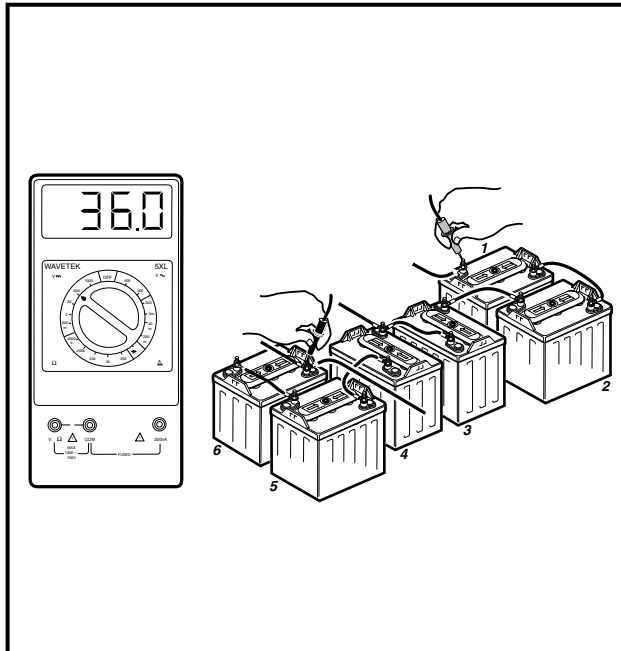

Figure 11-3 Battery Test

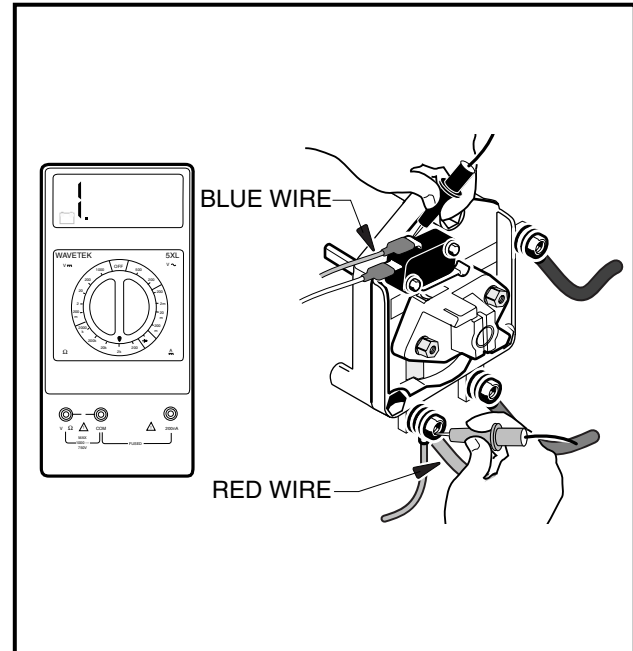

Figure 11-4 Key Switch Test

## TEST PROCEDURE 2 – KEY SWITCH

See General Warning, Section 10, Page 10-1.

1. Disconnect the battery cables as instructed. See **WARNING “To avoid unintentionally starting...” in General Warning, Section 10, Page 10-1**.
2. Place the red (+) probe of a multimeter (set at  $\Omega$ ) on the forward terminal of the Forward/Reverse switch and place the black (–) probe on the upper (COM) terminal of the Forward/Reverse anti-arcing limit switch (**Figure 11-4, Page 11-8**). With the key in the OFF position, the reading should be no continuity.
3. Insert the key and turn the key switch to the ON position. The reading should be continuity.
4. If the reading is incorrect at either of steps 2 or 3, check the wires and terminals. If no problems are found with the wires or terminals, replace the key switch. See **Section 12 – Electrical Components**.
5. Connect the battery cables, positive (+) cable first, and tighten to 110 in-lb (12.4 N·m). Coat with Battery Terminal Protector Spray (CCI P/N 1014305) to minimize corrosion.

### TEST PROCEDURE 3 – FORWARD/REVERSE ANTI-ARCING LIMIT SWITCH

See General Warning, Section 10, Page 10-1.

1. Disconnect the battery cables as instructed. See **WARNING “To avoid unintentionally starting...” in General Warning, Section 10, Page 10-1.**
2. Place the red (+) probe of the multimeter (set to  $\Omega$ ) on the common terminal of the limit switch, and place the black (–) probe on the normally open (NO) terminal. The reading should be continuity when the limit switch lever is pressed and no continuity when the lever is released (**Figure 11-5, Page 11-9**).
3. If the reading is incorrect at either lever position, replace switch. If readings are correct, check the wires, terminals and cam actuator on the Forward/Reverse switch rotor. If no problems are found, the problem is not in the switch. See **Section 12 – Electrical Components.**
4. Connect the battery cables, positive (+) cable first, and tighten to 110 in-lb (12.4 N·m). Coat with Battery Terminal Protector Spray (CCI P/N 1014305) to minimize corrosion.

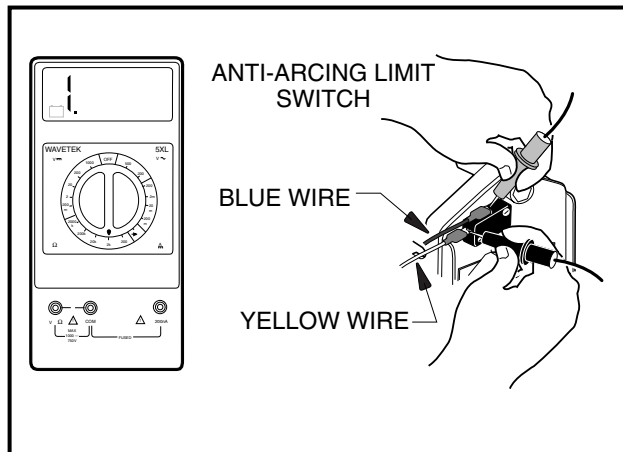

Figure 11-5 Forward/Reverse Anti-arcing Limit Switch Test

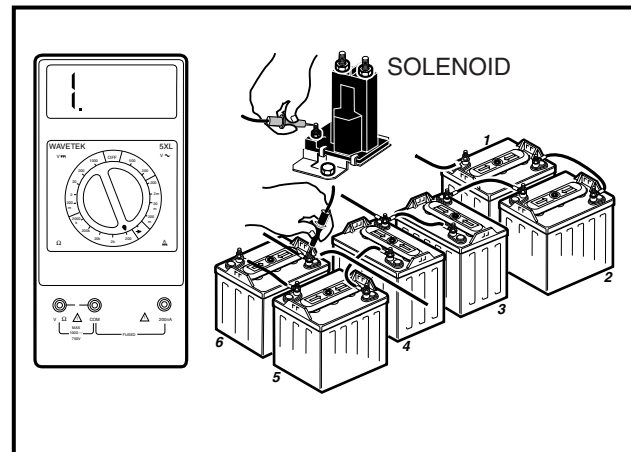

Figure 11-6 Accelerator Pedal Limit Switch Test

### TEST PROCEDURE 4 – ACCELERATOR PEDAL LIMIT SWITCH

See General Warning, Section 10, Page 10-1.

1. Disconnect the battery cables as instructed. See **WARNING “To avoid unintentionally starting...” in General Warning, Section 10, Page 10-1.**
2. Place the red (+) probe of the multimeter (set to 200  $\Omega$ ) on the terminal of the green wire at its connection on the activating coil post of the solenoid, and place the black (–) probe on the negative (–) post of battery no. 6 (**Figure 11-6, Page 11-9**). With the accelerator pedal fully up (not pressed), the reading should be no continuity.
3. Press the accelerator pedal. The reading should be continuity.
4. If either reading is incorrect, remove the V-Glide wiper switch housing cover and check for proper activation of the limit switch by the wiper arm.
5. Also make sure the 18-gauge green wire is connected to the normally closed (NC) terminal of the limit switch, and the 18-gauge black wire is connected to the common (COM) terminal. There should be no wire attached to the normally open (NO) terminal.
6. Connect the battery cables, positive (+) cable first, and tighten to 110 in-lb (12.4 N·m). Coat with Battery Terminal Protector Spray (CCI P/N 1014305) to minimize corrosion.

## TEST PROCEDURE 5 – SOLENOID ACTIVATING COIL

See General Warning, Section 10, Page 10-1.

1. Disconnect the battery cables as instructed. See **WARNING “To avoid unintentionally starting...”** in **General Warning, Section 10, Page 10-1.**
2. Place the red probe (+) of the multimeter (set to 200  $\Omega$ ) on one of the small activating coil posts of the solenoid and place the black (-) probe on the other small post. There should be a reading of 55-60  $\Omega$  (ohms) (**Figure 11-7, Page 11-10**).
3. If the reading is incorrect, replace the solenoid.
4. Connect the battery cables, positive (+) cable first, and tighten to 110 in-lb (12.4 N-m). Coat with Battery Terminal Protector Spray (CCI P/N 1014305) to minimize corrosion.

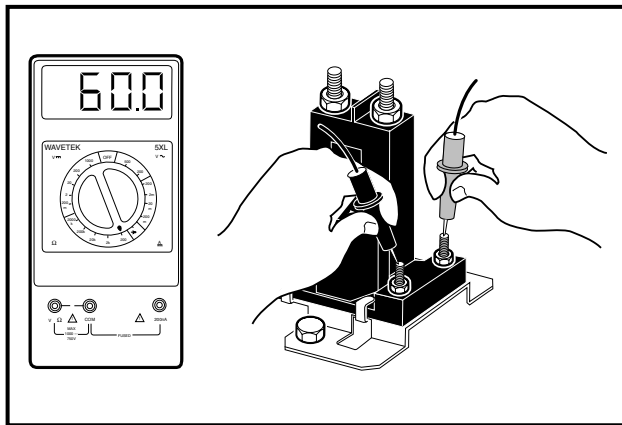

Figure 11-7 Solenoid Activating Coil Test

## TEST PROCEDURE 6 – REVERSE BUZZER

See General Warning, Section 10, Page 10-1.

1. Disconnect the battery cables as instructed. See **WARNING “To avoid unintentionally starting...”** in **General Warning, Section 10, Page 10-1.**
2. Remove the center dash panel. See **step 2 of Key Switch Removal, Section 12, Page 12-1.**
3. Disconnect the 18-gauge white wire at the reverse buzzer. Place the red (+) probe of a multimeter (set to 200  $\Omega$ ) on the large post of the solenoid (with the 6-gauge and the 18-gauge white wires attached), and place the black (-) probe on the terminal end of the 18-gauge white wire at the reverse buzzer. The reading should indicate continuity. If it is not, replace the 18-gauge white wire (**Figure 11-8, Page 11-11**).
4. Disconnect the 18-gauge orange wire at the reverse buzzer. Place the black (-) probe of a multimeter (set to  $\Omega$ ) on the receptacle fuse assembly at the 10-gauge red wire and 18-gauge orange wire connection, and place the red (+) probe on the terminal end of the 18-gauge orange wire at the reverse buzzer. The multimeter should indicate continuity. If not, replace the 18-gauge orange wire (**Figure 11-9, Page 11-11**).

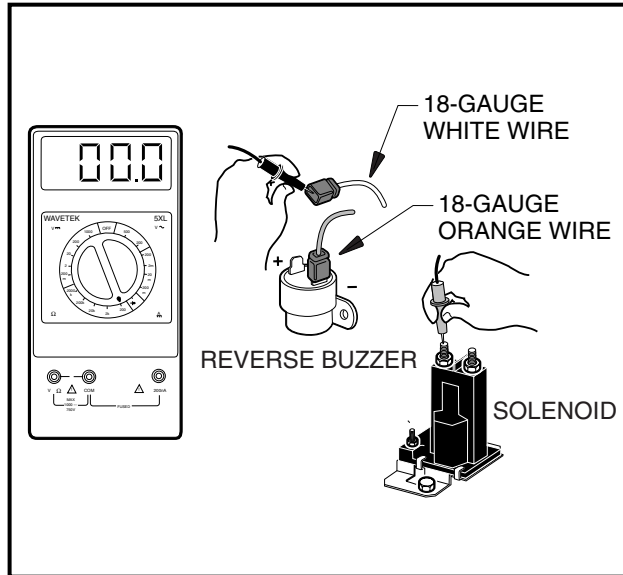

Figure 11-8 Reverse Buzzer Test – White Wire

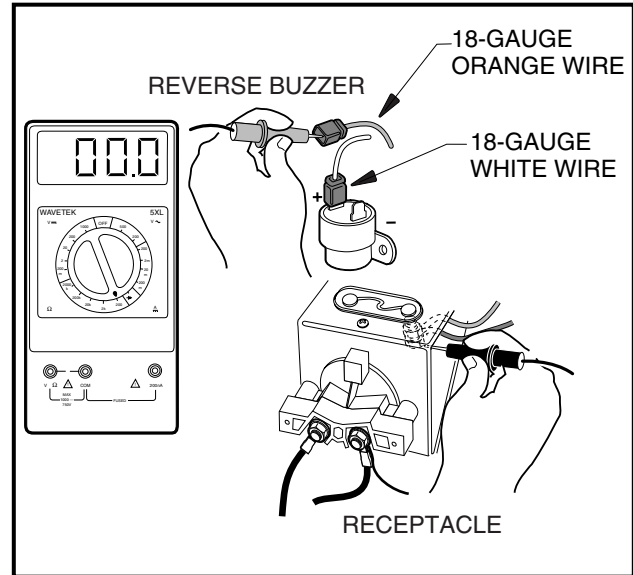

Figure 11-9 Reverse Buzzer Test – Orange Wire

5. If there is continuity in both wires, but the buzzer will not sound, replace the buzzer.
6. Connect the battery cables, positive (+) cable first, and tighten to 110 in-lb (12.4 N·m). Coat with Battery Terminal Protector Spray (CCI P/N 1014305) to minimize corrosion.

## TEST PROCEDURE 7 – RESISTORS

See General Warning, Section 10, Page 10-1.

### **⚠ WARNING**

- Do not touch hot resistors! Hot resistors can cause severe burns.

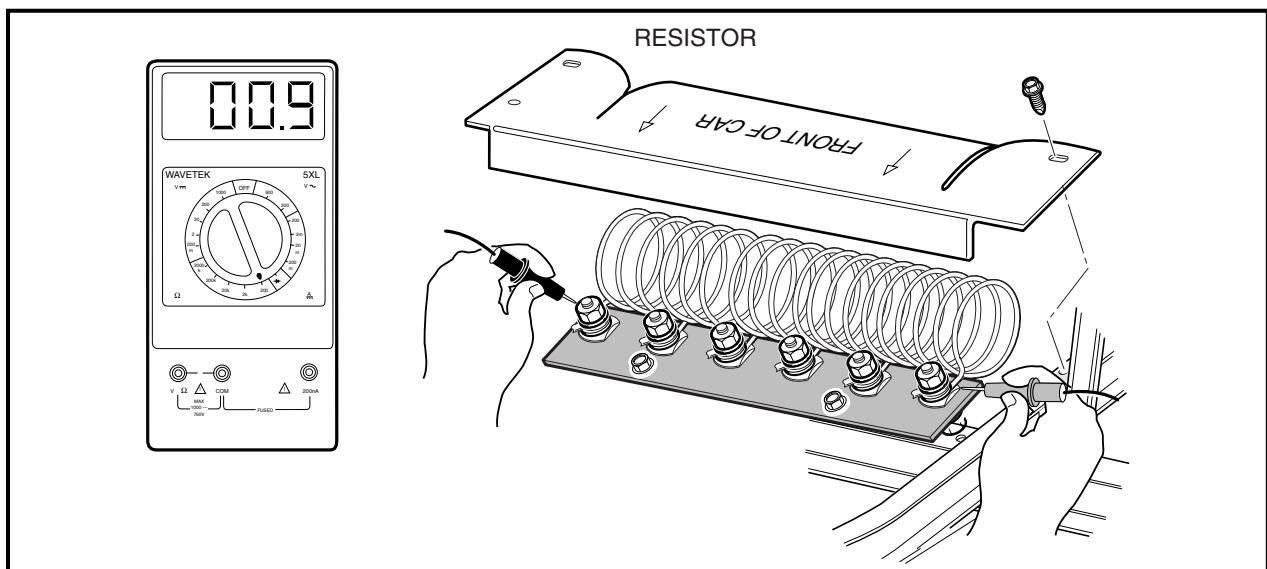

Figure 11-10 Resistor Test

**Test Procedure 7 – Resistors, Continued:**

1. Inspect the resistors for loose connections, damaged coils or wiring, or problems of any kind.
2. If there are no problems, place the red (+) probe of the multimeter (set to 200  $\Omega$ ) on the first resistor connection, and place the black (–) probe on the last resistor connection. The reading should be continuity or approximately 0.9  $\Omega$  (ohms) (**Figure 11-10, Page 11-11**).
3. If the reading is incorrect, check the resistors again for loose connections or damage. Replace any damaged parts.

**TEST PROCEDURE 8 – FORWARD/REVERSE SWITCH****See General Warning, Section 10, Page 10-1.**

1. Disconnect the battery cables as instructed. See **WARNING “To avoid unintentionally starting...”** in **General Warning, Section 10, Page 10-1**.
2. Use a multimeter set to 200  $\Omega$  to test the Forward/Reverse switch in both directions.
  - 2.1. With the Forward/Reverse switch in the FORWARD position, place the red (+) probe on the common terminal lug of the switch (with brown wire attached), and place the black (–) probe on the movable contact (with the purple wire attached) on the forward and reverse rotor (**Figure 11-11, Page 11-12**). The reading should be continuity.
  - 2.2. With the Forward/Reverse switch in the FORWARD position, place the red (+) probe on the forward terminal lug (with the 6-gauge red wire attached) of the Forward/Reverse switch, and place the black (–) probe on the movable contact (with the white wire attached) on the forward and reverse rotor (**Figure 11-12, Page 11-12**). The reading should be continuity.

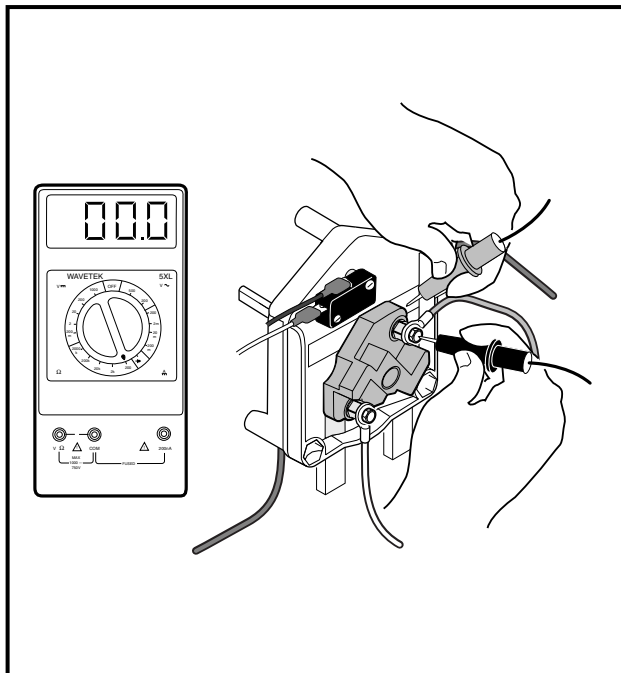

Figure 11-11 Forward/Reverse Switch Test – Step 2.1

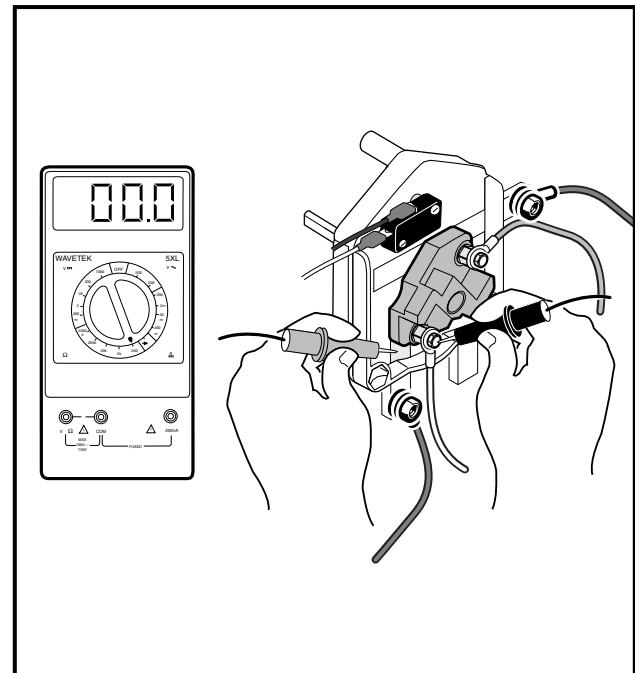

Figure 11-12 Forward/Reverse Switch Test – Step 2.2

- 2.3. With the Forward/Reverse switch in the REVERSE position, place the red (+) probe on the common terminal lug (with brown wire attached) of the Forward/Reverse switch, and place the black (–) probe on the movable contact (with the white wire attached) on the forward and reverse rotor (**Figure 11-13, Page 11-13**). The reading should be continuity.



- 2.4. With the Forward/Reverse handle in the REVERSE position, place the red (+) probe on the reverse terminal lug of the Forward/Reverse switch (with green wire attached), and place the black (-) probe on the movable contact (with the purple wire attached) on forward and reverse rotor (Figure 11-14, Page 11-13). Reading should be continuity.

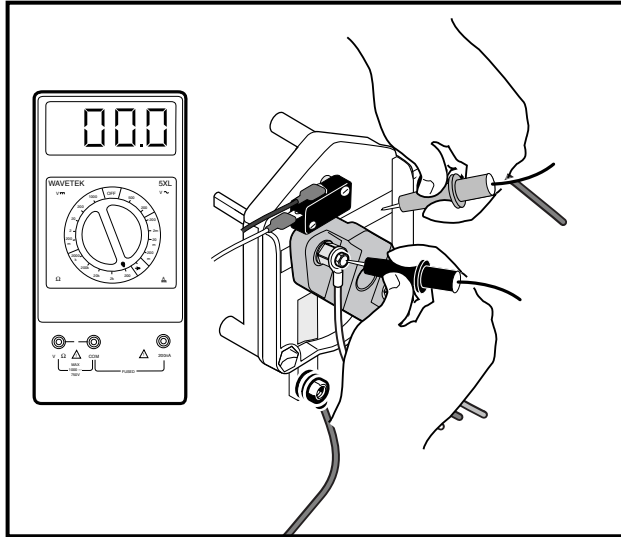

Figure 11-13 Forward/Reverse Switch Test – Step 2.3

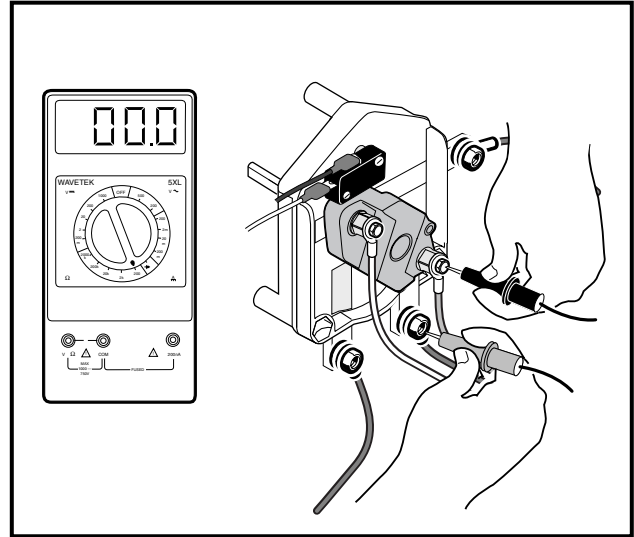

Figure 11-14 Forward/Reverse Switch Test – Step 2.4

3. If the reading is incorrect at any position in step 2, refer to Section 12 – Electrical Components.
4. Connect the battery cables, positive (+) cable first, and tighten to 110 in-lb (12.4 N-m). Coat with Battery Terminal Protector Spray (CCI P/N 1014305) to minimize corrosion.

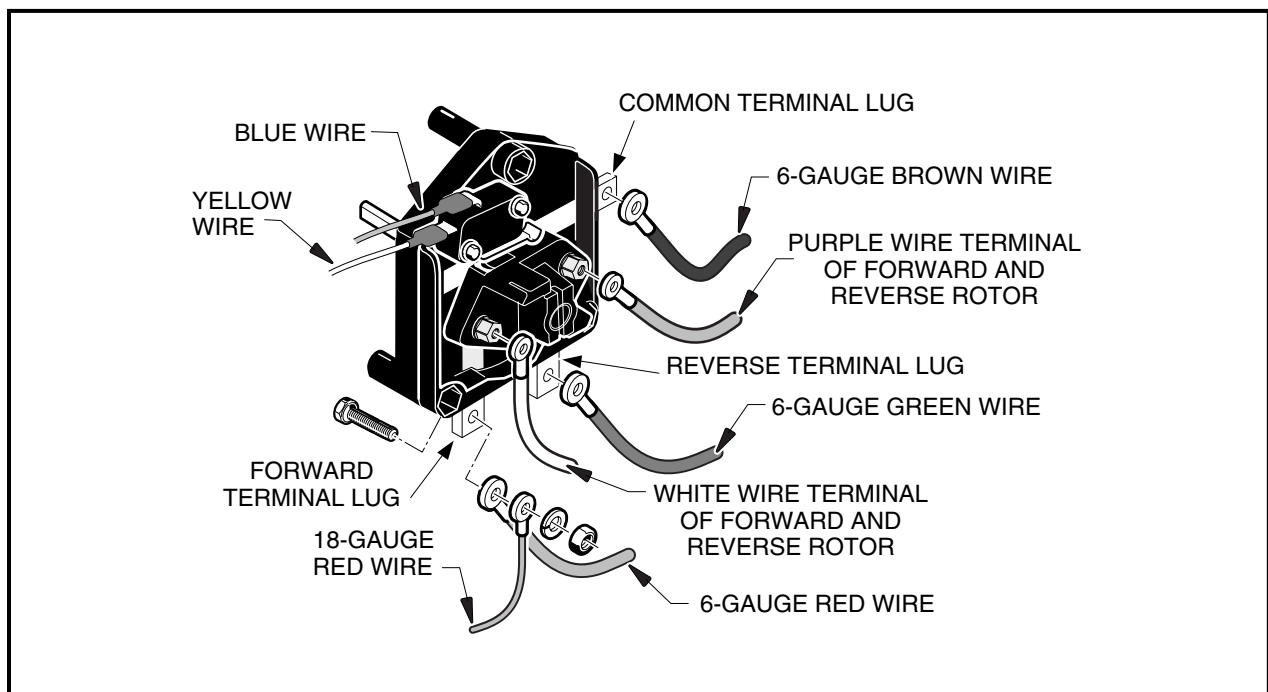

Figure 11-15 Forward/Reverse Switch

## TEST PROCEDURE 9 – MOTOR

See General Warning, Section 10, Page 10-1.

1. Disconnect the battery cables as instructed. See **WARNING “To avoid unintentionally starting...”** in **General Warning, Section 10, Page 10-1.**
2. Use a multimeter set to 200  $\Omega$  to test motor armature and motor stator.
  - 2.1. To test the motor armature place the Forward/Reverse handle in the NEUTRAL position, place the red (+) probe on the terminal (with the heavy purple wire attached) on the forward and reverse rotor, and place the black (-) probe on the last resistor coil connection (black and gray wires). The reading should be continuity (**Figure 11-16, Page 11-14**).
  - 2.2. To test motor stator, place Forward/Reverse handle in the NEUTRAL position, place the red (+) probe on the common terminal lug of the Forward/Reverse switch (brown wire), and place the black (-) probe on the negative post of battery no. 6. The reading should be continuity (**Figure 11-17, Page 11-14**).
3. If either reading in step 2 is incorrect, check for loose wires or terminals. Refer to Section 15 – Motor for further testing and repair procedures.
4. Connect the battery cables, positive (+) cable first, and tighten to 110 in-lb (12.4 N·m). Coat with Battery Terminal Protector Spray (CCI P/N 1014305) to minimize corrosion.

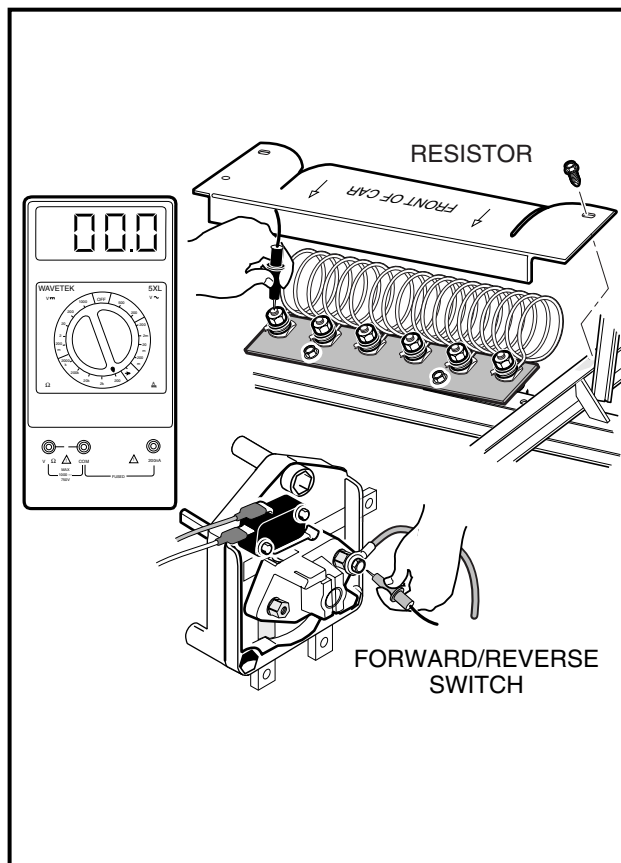

Figure 11-16 Motor Test – Armature

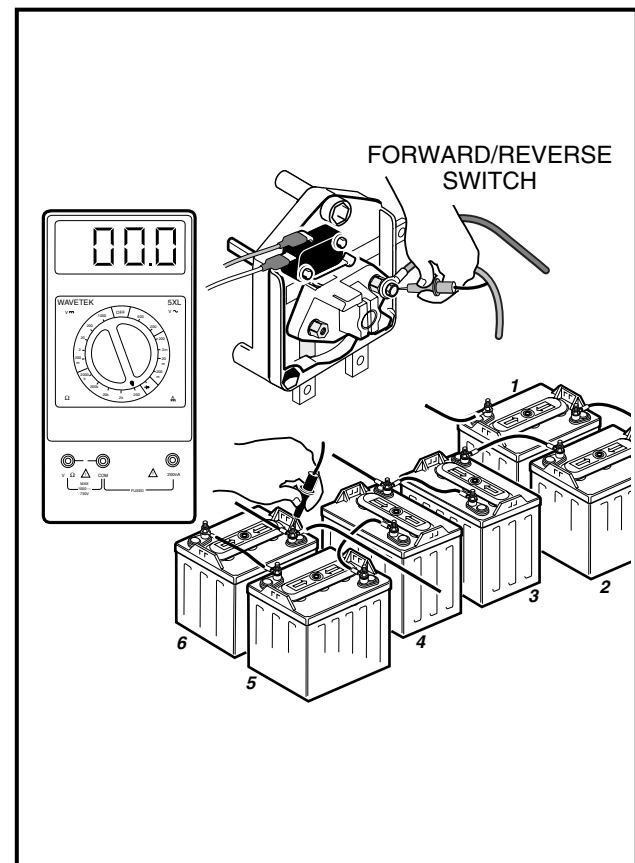

Figure 11-17 Motor Test – Stator

## TEST PROCEDURE 10 – SOLENOID CONTACTS (POWER OFF)

See General Warning, Section 10, Page 10-1.

If the vehicle begins to move as soon as the Forward/Reverse handle is placed in the FORWARD or REVERSE position, without having pressed the accelerator pedal, the solenoid is probably welded closed. Test the solenoid as follows:

1. Place the red (+) probe of a multimeter (set at  $\Omega$ ) on one of the large terminal posts on the solenoid, and place the black (-) probe on the other large terminal post on the solenoid. The reading should be no continuity (**Figure 11-18, Page 11-15**).
2. If the reading is incorrect, replace the solenoid and snubber. **See Section 12 – Electrical Components.**

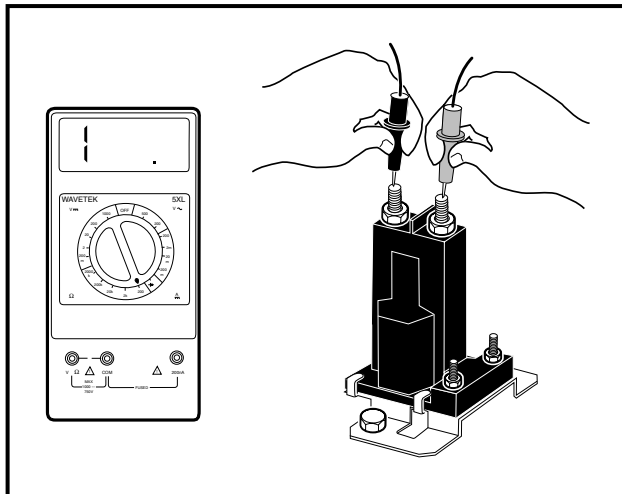

Figure 11-18 Solenoid Contacts – Power Off

## TEST PROCEDURE 11 – SOLENOID CONTACTS (POWER ON)

See General Warning, Section 10, Page 10-1.

### **⚠ DANGER**

- Before connecting the batteries, disconnect the gray wire from the resistor board to the A2 motor terminal and remove the wire from the vehicle. Then raise the rear end of the vehicle until the rear wheels are off the floor. See WARNING “Lift only one end of the vehicle...” in General Warning, Section 10, Page 10-1. With the gray wire removed, the solenoid can be activated without supplying power to the rear wheels. Failure to disconnect the gray wire can cause the vehicle to start abruptly.

1. If the battery cables were disconnected, reconnect them, positive cable first. Tighten terminal hardware to 110 in-lb (12.4 N·m). **See preceding DANGER.**

**Test Procedure 11 – Solenoid Contacts (Power On), Continued:**

2. With Forward/Reverse handle in the NEUTRAL position, place red (+) probe of multimeter (set to  $\Omega$ ) on positive post of battery no. 1. Place black (–) probe on the forward terminal lug on Forward/Reverse switch. If reading is no continuity, inspect the wire assembly between these two positions and replace the wire assembly if it has failed (**Figure 11-19, Page 11-16**).
3. With the key switch in the ON position and the Forward/Reverse handle in the FORWARD position, press the accelerator pedal to the floor (solenoid will click). With the accelerator pedal pressed, place the red (+) probe of a multimeter (set to  $\Omega$ ) on one of the large posts on the solenoid, and place the black (–) probe on the other large post on the solenoid. The multimeter should indicate continuity. If the reading is incorrect, replace the solenoid (**Figure 11-20, Page 11-16**). See following **WARNING**.

**WARNING**

- Remove key, place Forward/Reverse handle in the NEUTRAL position, and disconnect batteries, negative cable first, as shown in Section 10, Figure 10-1, Page 10-2 before replacing solenoid or installing gray wire from resistor board to A2 motor terminal.

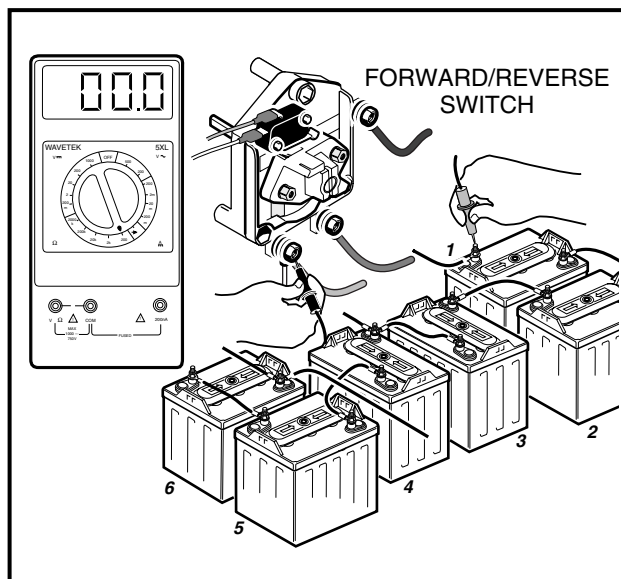

Figure 11-19 Solenoid Contacts – Power On, Step 2

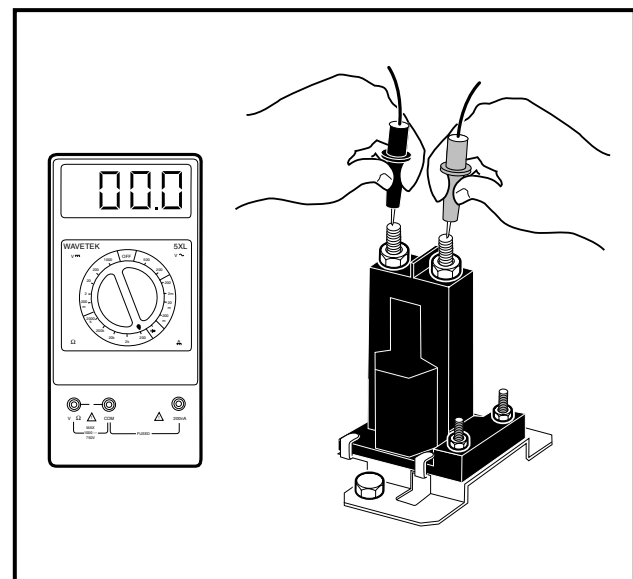

Figure 11-20 Solenoid Contacts – Power On, Step 3

**TEST PROCEDURE 12 – V-GLIDE WIPER SWITCH**

See General Warning, Section 10, Page 10-1.

1. Remove the V-Glide wiper switch cover and observe the wiper arm brush as it moves across the fixed contacts. There should be sufficient spring pressure in the arm to keep the wiper arm brush firmly against each of the fixed contacts as it travels across them. There should also be proper surface contact between the brush and each of the fixed contacts as shown (**Figure 11-21, Page 11-17**).
2. Inspect both the brush and fixed contacts for excessive pitting, burns, or wear. If the brush is worn to the wear limit line it must be replaced (**Figure 11-22, Page 11-17**). See Section 12 – Electrical Components.

3. Make sure all the contacts are tight and the V-Glide wiper switch housing is not melted or burned around the contacts. If the housing or fixed contacts are damaged, the entire wiper switch housing with contacts must be replaced.
4. Make sure nuts attaching wires to the backs of the fixed contacts are tightened to 40 in-lb (4.5 N·m).

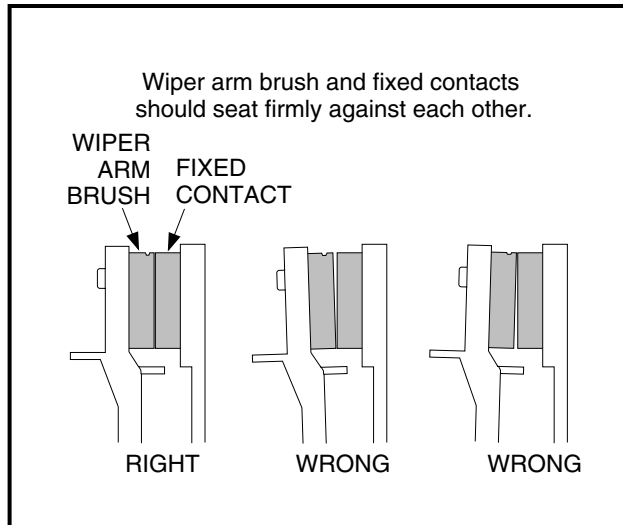

Figure 11-21 Wiper Arm Brush and Fixed Contacts

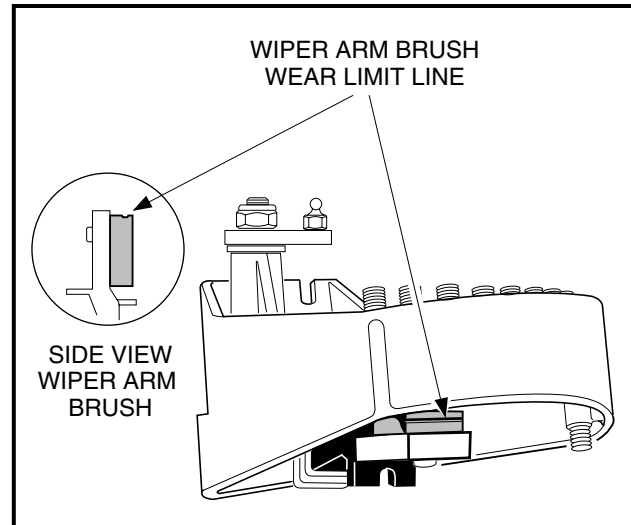

Figure 11-22 Wiper Arm Brush Wear Limit Line



## SECTION 12 – ELECTRICAL COMPONENTS

### **⚠ DANGER**

- See General Warning, Section 10, Page 10-1.

### **⚠ WARNING**

- See General Warning, Section 10, Page 10-1.

## KEY SWITCH

See General Warning, Section 10, Page 10-1.

### Testing the Key Switch

See Test Procedure 2, Section 11, Page 11-8.

### Key Switch Removal

1. Disconnect the battery cables as instructed. See **WARNING “To avoid unintentionally starting...”** in **General Warning, Section 10, Page 10-1.**
2. Remove the center dash panel.
  - 2.1. Remove the plastic cap (1) covering the mounting screw (2) on each side of the center dash panel (3) (**Figure 12-1, Page 12-1**).
  - 2.2. Loosen, but do not remove, the screw (2) on each side of the center dash panel (3).
  - 2.3. Insert screwdriver at the top center of the dash between dash and cowl brace. Gently pry center dash out slightly from under edge of cowl brace.

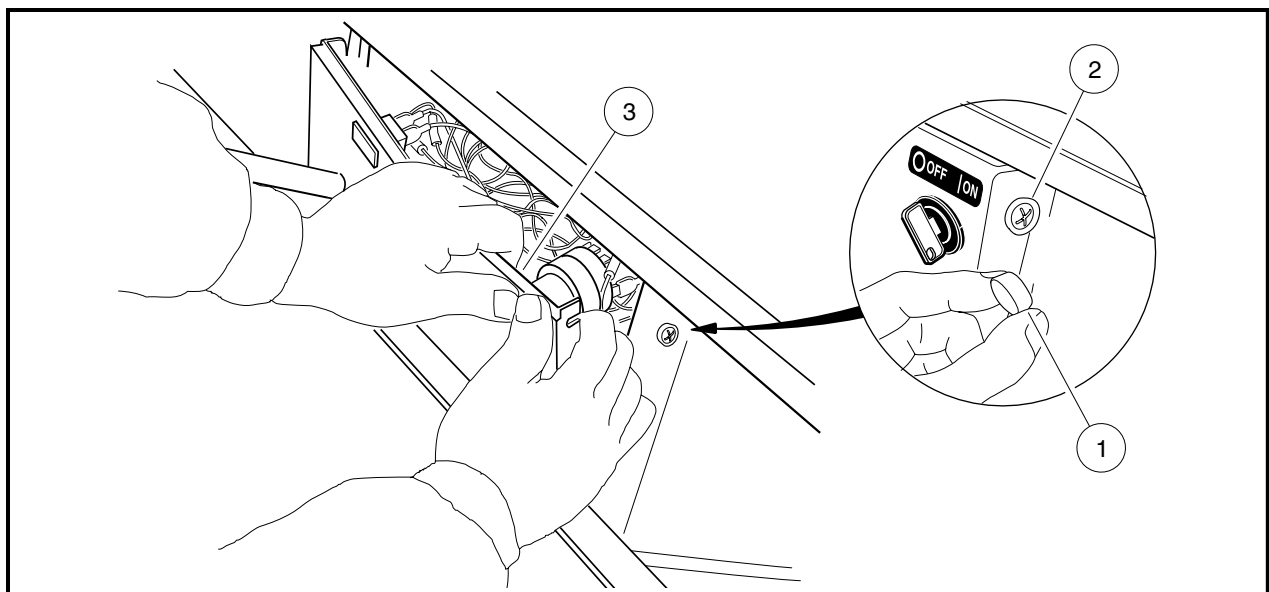

Figure 12-1 Dash Removal

**Key Switch Removal, Continued:**

- 2.4. Pull center dash out approximately 1 inch (2.5 cm) from the frame and then bend the top right corner of the center dash inward while pulling the top of the panel out and down. **See following NOTE.**

**NOTE:** Bending the top right corner of the center dash inward during removal will prevent the contacts on the back of the key switch from touching the metal frame around the dash.

- 2.5. Slide center dash panel up the steering column by snapping the top out and then rotating the panel out and up.
3. Disconnect the wires from the key switch. Do not allow the wires to touch.
4. From the back of the dash panel, push down on the retaining tabs surrounding the key switch (4) and remove the key switch cap (8). Hold the key switch and remove the switch retaining nut (6) from the outside of the dash panel (**Figure 12-2, Page 12-2**).

**Key Switch Installation**

1. Position the key switch and flat washer (9) in the center dash, then install and tighten the switch retaining nut (6) to 40 in-lb (4.5-m). Install key switch cap (8) in the center dash (**Figure 12-2, Page 12-2**).
2. Refer to the wiring diagram to connect the wires to the key switch terminals. Tighten the terminal screws to 7 in-lb (0.8 N-m). **See Wiring Diagram, Section 11, Page 11-4.** Coat the terminals with Battery Terminal Protector Spray (CCI P/N 1014305).
3. Install the center dash by reversing the removal procedure. Make sure the key switch terminals (7) do not touch the frame and that the center dash panel is properly seated and snapped into place (**Figure 12-2, Page 12-2**).
4. Connect the battery cables, positive (+) cable first, and tighten to 110 in-lb (12.4 N-m). Coat with Battery Terminal Protector Spray (CCI P/N 1014305) to minimize corrosion.

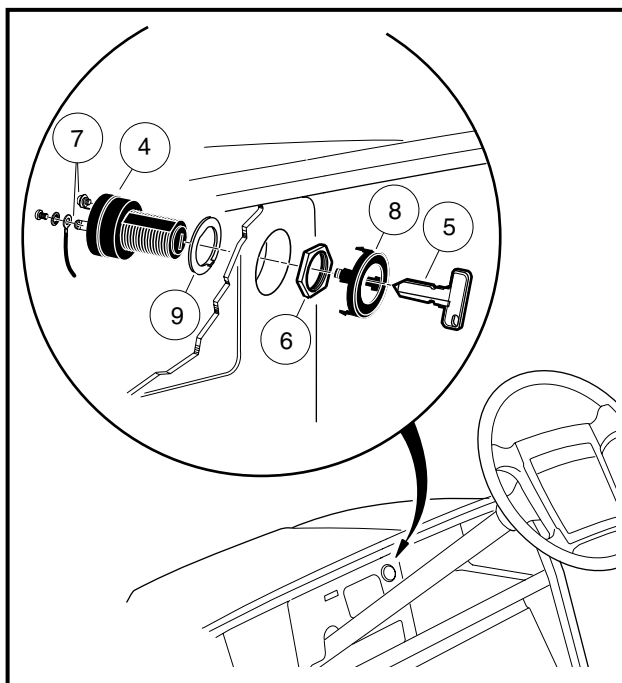

**Figure 12-2 Key Switch**



## FORWARD/REVERSE ANTI-ARCING LIMIT SWITCH

See General Warning, Section 10, Page 10-1.

The Forward/Reverse anti-arcing limit switch is located on the Forward/Reverse switch and is activated by a cam on the Forward/Reverse switch rotor.

### Testing the Anti-arcing Limit Switch

See Test Procedure 3, Section 11, Page 11-9.

### Anti-arcing Limit Switch Removal

1. Remove the nuts, lock washers, and screws attaching the anti-arcing limit switch to the Forward/Reverse switch (Figure 12-3, Page 12-3).

### Anti-arcing Limit Switch Installation

1. Position the anti-arcing limit switch (2) on the Forward/Reverse switch housing and install the screws, lock washers, and nuts. Tighten the screws to 5 in-lb (0.6 N·m) (Figure 12-3, Page 12-3).
2. Connect the blue wire (9) to the common (COM) terminal (6) and the yellow wire (8) to the normally open (NO) terminal (7) (Figure 12-3, Page 12-3).
3. After installation, make sure the switch makes an audible click (makes and breaks contact) when the forward and reverse rotor is turned. If it does not click, inspect the forward and reverse rotor and limit switch for damage.

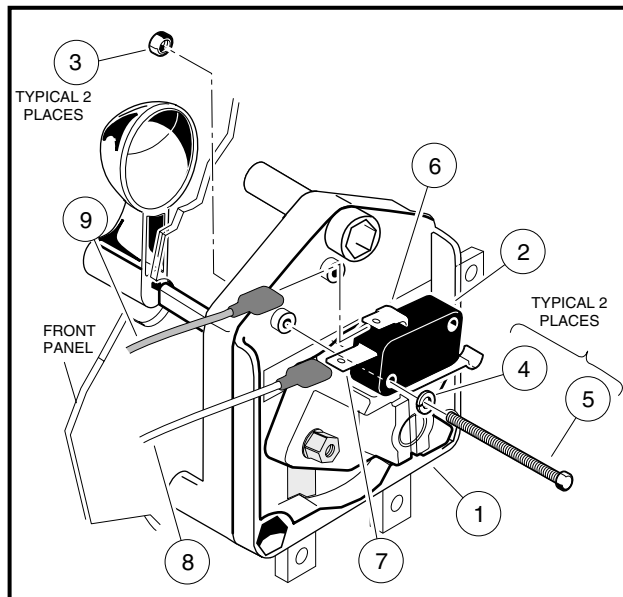

Figure 12-3 Forward/Reverse Anti-arcing Limit Switch

## ACCELERATOR PEDAL LIMIT SWITCH

See General Warning, Section 10, Page 10-1.

### Testing the Accelerator Pedal Limit Switch

See Test Procedure 4, Section 11, Page 11-9.

## Accelerator Pedal Limit Switch Removal

1. Disconnect the battery cables as instructed. **See WARNING “To avoid unintentionally starting...” in General Warning, Section 10, Page 10-1.**
2. Remove no. 5 and no. 6 batteries from vehicle. **See Figure 10-1, Section 10, Page 10-2.**
3. Remove the cover (10) from the V-Glide wiper switch housing (1) (**Figure 12-9, Page 12-10**).
4. Disconnect the accelerator rod from the ball stud (5) on the wiper switch.
5. Remove and retain the screws (19), lock washers (16), and nuts (22) attaching the limit switch (20) to the wiper switch.
6. Disconnect the green (35) and black wires (36) from the limit switch.

## Accelerator Pedal Limit Switch Installation

1. Position accelerator pedal limit switch (20) on V-Glide wiper switch body and install mounting screws (19), lock washers (16), and nuts (22). Tighten screws to 5 in-lb (0.6 N·m) (**Figure 12-9, Page 12-10**).
2. Connect the accelerator rod ball joint to the ball stud (5) on the wiper switch.
3. Connect the green wire (35) to the normally closed (NC) terminal and the black wire (36) to the common (COM) terminal of the limit switch. The normally open (NO) terminal should have no wire attached to it.
4. Install cover (10) on V-Glide wiper switch (make sure all three tabs snap into place).
5. Install the no. 5 and no. 6 batteries and connect battery cables, positive cable first. Tighten terminal hardware to 110 in-lb (12.4 N·m). **See Figure 10-1, Section 10, Page 10-2.**

## REVERSE BUZZER

---

**See General Warning, Section 10, Page 10-1.**

### Testing the Reverse Buzzer

**See Test Procedure 6, Section 11, Page 11-10.**

### Reverse Buzzer Removal

1. Disconnect the battery cables as instructed. **See WARNING “To avoid unintentionally starting...” in General Warning, Section 10, Page 10-1.**
2. Remove the center dash panel. **See step 2 of Key Switch Removal on page 12-1.**
3. Remove the orange and white wires from the buzzer terminals. **See Figure 11-2, Section 11, Page 11-4.** Remove the screws attaching the buzzer to the center dash.

### Reverse Buzzer Installation

1. Install reverse buzzer and center dash by reversing removal procedures. Tighten screws to 4 in-lb (0.45 N·m).
2. Connect the battery cables, positive (+) cable first, and tighten to 110 in-lb (12.4 N·m). Coat with Battery Terminal Protector Spray (CCI P/N 1014305) to minimize corrosion.

## SOLENOID

---

**See General Warning, Section 10, Page 10-1.**

The solenoid is mounted in front of the no. 3 and no. 4 batteries. **See Figure 10-1, Section 10, Page 10-2.** It has two sets of terminal posts. The two large terminal posts are power contact terminals and the two small posts are activating coil terminals.

### Testing the Solenoid

**See Test Procedure 5, Section 11, Page 11-10.**

**See Test Procedure 10, Section 11, Page 11-15.**

**See Test Procedure 11, Section 11, Page 11-15.**

### Solenoid Removal

1. Disconnect the battery cables as instructed. **See WARNING “To avoid unintentionally starting...” in General Warning, Section 10, Page 10-1.**
2. Disconnect all wires from solenoid.
3. Remove the two thread-rolling screws securing the solenoid to the vehicle.

### Solenoid Installation

1. Position the solenoid with the small posts toward the front of the vehicle. Install one of the mounting screws through the driver-side hole on the solenoid base and into the corresponding hole in the mounting plate (**Figure 12-4, Page 12-6**). Tighten screw to 50 in-lb (7.3 N·m).
2. Install passenger-side screw and tighten to 50 in-lb (5.6 N·m) (**Figure 12-4, Page 12-6**).
3. Install diode assembly onto small solenoid posts. Make sure the direction of the diode is correct. The red insulated terminal of the diode assembly should be installed on the same post that the 18-gauge yellow wire is attached, and the clear insulated terminal of the diode assembly should be installed on the same post that the 18-gauge green wire is attached (**Figure 12-5, Page 12-6**). **See following WARNING.**

### **⚠ WARNING**

- **Do not damage snubber when mounting solenoid.**
  - **Install both mounting screws. Failure to install both screws can result in solenoid and electrical system damage and failure.**
4. Attach snubber assembly to frame on either the passenger or the driver-side of the solenoid using a wire tie and cable tie mounting base (**Figure 12-4, Page 12-6**).
  5. Attach wiring to solenoid. Connect black wire from snubber to the large rear solenoid post that the 6-gauge white wire (from the speed switch) is attached. Connect red wire from the snubber to the large front post that the 18-gauge and 6-gauge white wires are attached. **See following CAUTION.**

### **CAUTION**

- **Make sure the wires are routed so the wire from the FORWARD and REVERSE rotor does not pull on other wires as the Forward/Reverse handle is shifted.**
6. Using a low profile wrench to hold the inner nuts on the solenoid posts in place, tighten the outer nuts of the large posts to 100 in-lb (11.3 N·m). Tighten the outer nuts of the small solenoid posts to 4 in-lb (0.5 N·m) (**Figure 12-5, Page 12-6**). **See following WARNING.**

**Solenoid Installation, Continued:****⚠ WARNING**

- Failure to hold the inner nuts on the solenoid posts while tightening the outer nuts or not tightening the outer nuts to the proper specifications can result in solenoid damage and failure.

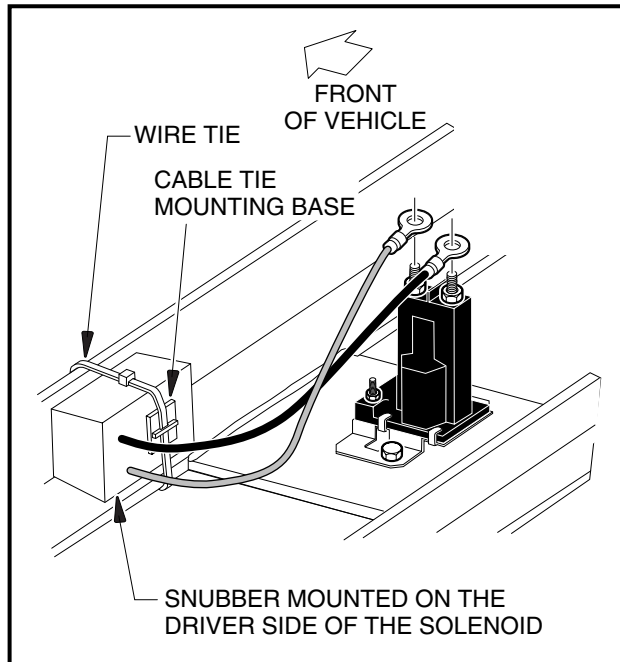

Figure 12-4 Mount Solenoid

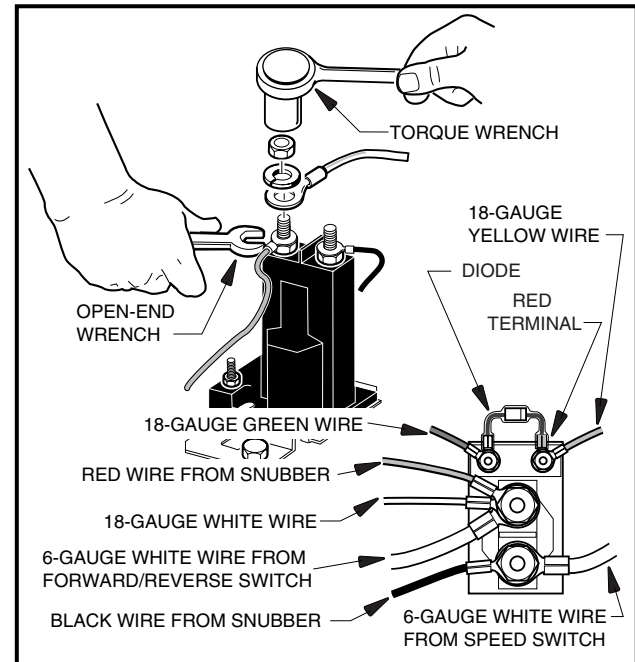

Figure 12-5 Connect Solenoid Wires

**Solenoid Snubber**

The solenoid snubber circuit is an arc suppression device that reduces the amount of sparking created as the solenoid contacts open while under a current load. This device minimizes pitting of the contacts and increases solenoid life. There is no method for troubleshooting the snubber circuit. If the solenoid fails, the snubber should also be replaced.

**RESISTORS**

**See General Warning, Section 10, Page 10-1.**

The resistors are attached to the resistor mounting board, which is located behind the batteries.

**Testing the Resistors**

**See Test Procedure 7, Section 11, Page 11-11.**

**Resistor Removal**

1. Disconnect the battery cables as instructed. **See WARNING “To avoid unintentionally starting...” in General Warning, Section 10, Page 10-1.**
2. Loosen, but do not remove, the nuts (1) that secure the resistors (R1 through R5) to the mounting board and then slide the resistors out from under the washers (3) (**Figure 12-6, Page 12-7**).

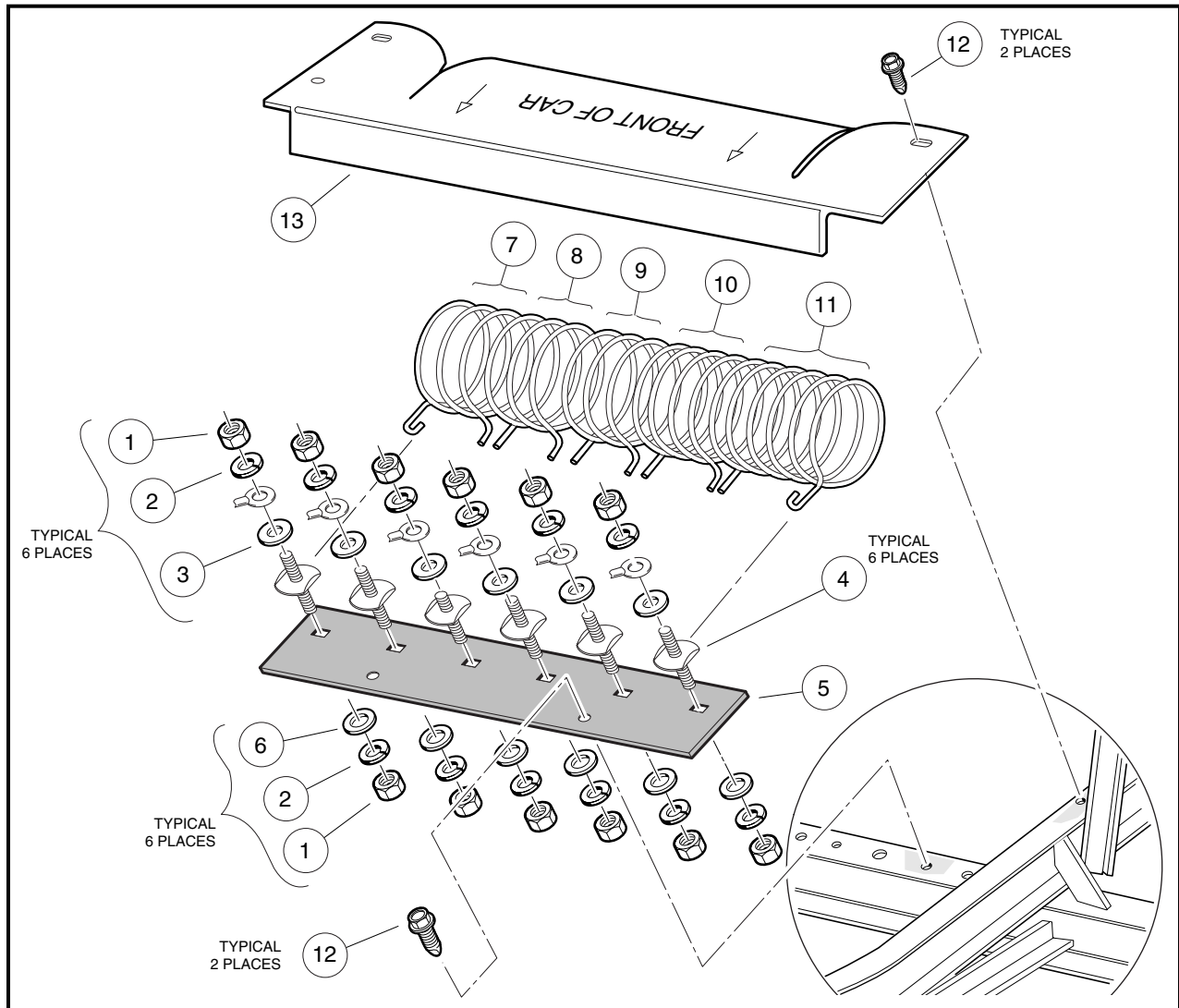

Figure 12-6 Mounting Board and Resistors

## Resistor Installation

1. Position resistor ends under washers (3) and tighten nuts to 95 in-lb (11 N·m) (**Figure 12-6, Page 12-7**).
2. Connect the battery cables, positive (+) cable first, and tighten to 110 in-lb (12.4 N·m). Coat with Battery Terminal Protector Spray (CCI P/N 1014305) to minimize corrosion. **See following CAUTION and NOTE.**

## CAUTION

- Be sure the motor wires are secured in wire ties so they cannot come into contact with the resistors.
- Be sure resistors are no closer than one inch to resistor shield. If resistors are closer than one inch to resistor shield, adjust the resistors.
- If a 3-1/2 horsepower motor is being used in conjunction with a V-Glide wiper switch, the fourth and fifth speed resistor coils must be replaced with new coils (CCI P/N 1014654 and 1014655).

**Resistor Installation, Continued:**

**NOTE:** Make sure resistor coils do not touch each other. The vehicle will not run properly if any coils are touching.

Make sure the resistor coils are installed in the proper order (**Figure 12-6, Page 12-7**). Resistor 1 has the smallest diameter wire and the greatest number of coils. Resistor 5 has the largest diameter wire and the smallest number of coils.

## WIPER SWITCH

---

**See General Warning, Section 10, Page 10-1.**

The V-Glide wiper switch is located in the battery compartment next to battery no. 6. The wiper switch arm adjustment should be checked if the brush on the V-Glide wiper switch is replaced. The pedal group adjustments should be checked if any of the pedal group or the accelerator rod has been adjusted, removed, or replaced. **See Section 5 – Accelerator and Brake Pedal Group, in the DS Golf Car Maintenance and Service Manual. See also following WARNING.**

### **WARNING**

---

- Be sure the V-Glide wiper switch arm shaft rotates freely in the housing. If the wiper switch arm shaft binds or sticks, it must be replaced.
- Make sure the V-Glide wiper switch assembly is securely fastened to the frame after installation.

The V-Glide wiper switch assembly should be inspected on a monthly basis for cracks or damage and to verify it is securely attached to the vehicle frame. **See following CAUTION.**

### **CAUTION**

---

- Inspect the V-Glide wiper switch housing for cracks or damage before installation. If the housing is cracked or damaged, the entire housing with fixed contacts must be replaced.
- When washing the vehicle, do not direct the water stream at the wiper switch.
- Do not operate the vehicle without the V-Glide wiper switch cover in place.

## Wiper Switch Arm Adjustment

The contact surfaces on the wiper switch arm brush and the fixed contacts must be parallel to ensure efficient operation of the V-Glide wiper switch (**Figure 12-7, Page 12-9**). Adjust arm contact as follows:

1. Disconnect the battery cables as instructed. **See WARNING “To avoid unintentionally starting...” in General Warning, Section 10, Page 10-1.**
2. Remove the cover (10) from the V-Glide wiper switch housing (1) (**Figure 12-9, Page 12-10**).
3. Test the wiper switch arm and fixed contacts for proper adjustment:
  - 3.1. With a dry erase marker, completely color each of the fixed contacts.
  - 3.2. Sweep the V-Glide wiper switch arm brush back and forth across the fixed contacts. Scraping of the ink should show contact on at least 30% of the surface on each fixed contact. If 30% contact is not shown, surface contact should be adjusted.

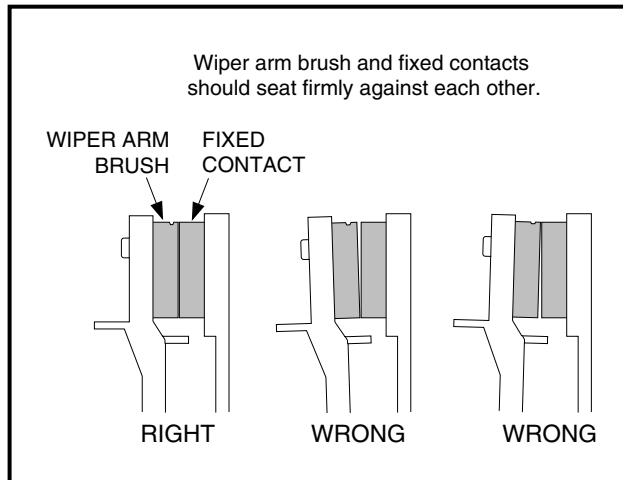

Figure 12-7 Wiper Arm Brush and Fixed Contacts

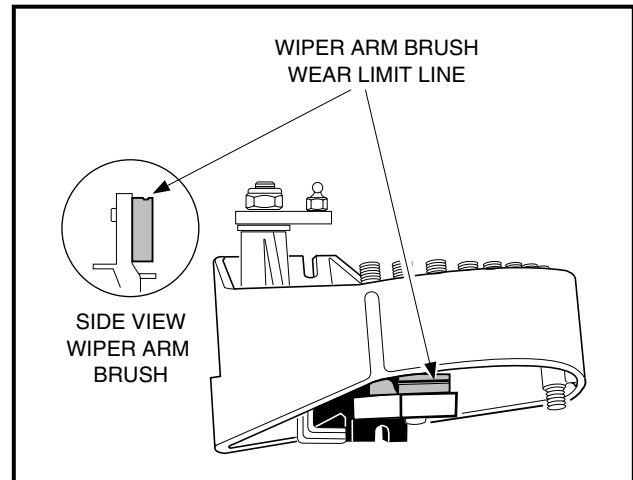

Figure 12-8 Wiper Arm Brush Wear Limit Line

4. To adjust surface contact, turn the adjustment screw (14) (Figure 12-9, Page 12-10) until the surfaces of the wiper switch arm brush and fixed contacts are parallel (Figure 12-7, Page 12-9). See following NOTE.

**NOTE:** If the wiper switch arm brush is worn to or beyond the wear limit line, it should be replaced (Figure 12-8, Page 12-9). If any of the fixed contacts are excessively worn, pitted, or burned, the entire wiper switch housing with fixed contacts must be replaced.

*A thread locking compound has been placed on the threads of the contact studs to prevent removal of the fixed contacts.*

5. Proceed to Wiper Switch Adjustment.

## Wiper Switch Adjustment

Each of the adjustments listed in the following **WARNING** affects V-Glide wiper switch adjustment. To ensure proper vehicle operation, if any one item requires adjustment, all must be checked, and adjusted if necessary, in the order listed.

### **▲ WARNING**

- To properly adjust wiper switch, check and adjust if necessary, the following items in the order listed:
  - Brake pedal and cable adjustment. See Section 5 in the DS Golf Car Maintenance and Service Manual.
  - Accelerator rod adjustment. See Section 5 in the DS Golf Car Maintenance and Service Manual.
  - Accelerator pedal stop adjustment. See Section 5 in the DS Golf Car Maintenance and Service Manual.
  - Park brake adjustment. See Section 5 in the DS Golf Car Maintenance and Service Manual.
- Failure to check all adjustments in the order listed could result in improper vehicle operation, property damage, or severe personal injury.

## Wiper Switch Arm Brush Replacement

1. Disconnect the battery cables as instructed. See **WARNING “To avoid unintentionally starting...”** in **General Warning, Section 10, Page 10-1.**
2. Disconnect the accelerator rod from the V-Glide wiper switch ball stud (5) and place the wiper switch arm on the topmost fixed contact (**Figure 12-9, Page 12-10**).
3. Remove the cap protector (25), nut (30), and lock washer (31) from the bolt (9) and remove the two 6-gauge white wires (32 and 33).
4. Remove the second nut (3) from the bolt (9) and then remove the bolt from the V-Glide wiper switch housing (1).

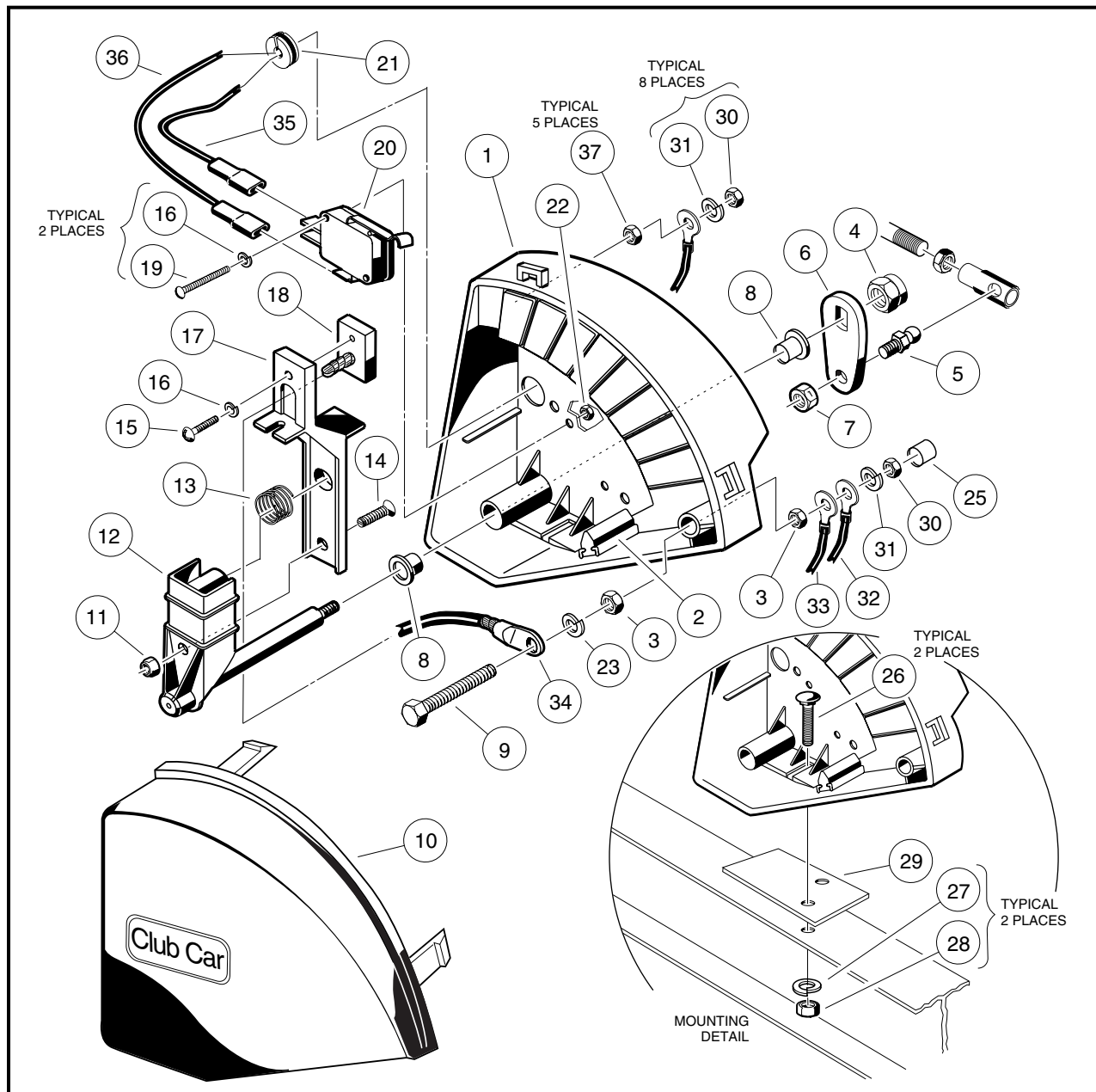

Figure 12-9 V-Glide Wiper Switch



5. Remove the third nut (3) and lock washer (23) and wire (34) from the bolt (9) (**Figure 12-9, Page 12-10**).
6. Replace the wiper switch arm brush (18) as follows:
  - 6.1. Remove screw (15) and lock washer (16). Pull the wiper switch arm (17) away from the fixed contacts.
  - 6.2. Remove brush (18) by pulling wire through hole in wiper switch arm (17).
  - 6.3. Install the new wiper switch arm brush assembly (18) into the wiper switch arm (17).
  - 6.4. Install the screw (15) and lock washer (16) through the wiper switch arm into the brush. Tighten the screw to 7 in-lb (0.8 N·m).
7. Install the arm brush wire terminal (34) onto the bolt (9) and then install the nut (3) and lock washer (23). Thread the nut against the arm brush wire terminal and tighten it to 40 in-lb (4.5 N·m).
8. Install the bolt (9) through the wiper switch housing (1) then install the nut (3) onto the bolt. Tighten the nut to 40 in-lb (4.5 N·m).
9. Install the 6-gauge white wire from the first resistor and the 6-gauge white wire from the solenoid onto the bolt (9), then install the lock washer (31) and nut (30). Tighten nut to 40 in-lb (4.5 N·m).
10. Check wiper switch arm brush contact for proper adjustment. **See Wiper Switch Arm Adjustment on page 12-8.**
11. Connect the accelerator rod to the V-Glide wiper switch ball stud (5).
12. Install the V-Glide wiper switch cover (10).
13. Install the no. 5 and no. 6 batteries.
14. Connect the battery cables, positive (+) cable first, and tighten to 110 in-lb (12.4 N·m). Coat with Battery Terminal Protector Spray (CCI P/N 1014305) to minimize corrosion.

### Wiper Switch Removal

1. Remove battery nos. 5 and 6 from the vehicle. **See Figure 10-1, Section 10, Page 10-2.**
2. Remove nuts (30) and lock washers (31), then remove resistor wires from wiper switch (**Figure 12-9, Page 12-10**).
3. Remove the cover (10) from the wiper switch (**Figure 12-9, Page 12-10**).
4. Disconnect the black wire (36) from the charger receptacle.
5. Disconnect the green wire (35) from the small post on the solenoid.
6. Remove nuts (28) and lock washers (27) securing V-Glide wiper switch to vehicle frame, then remove the wiper switch from vehicle. Secure shim (29) to vehicle frame.

### Wiper Switch Disassembly

1. Remove the nut (3) and slide the bolt (9) out of the wiper switch housing (**Figure 12-9, Page 12-10**).
2. Remove the nut (4) and bell crank (6).
3. Slide wiper switch arm assembly out of the V-Glide wiper switch housing (1).
4. Disassemble the wiper switch arm assembly by loosening the adjustment screw (14) and nylon lock nut (11) and removing the spring (13).
5. To remove the bearings (8) lightly tap them from the back with a punch.

### Wiper Switch Assembly

1. Install bearings (8) into the wiper switch housing by lightly tapping them with a plastic hammer. Make sure that the collars of the bearings are flush against the wiper switch housing (**Figure 12-9, Page 12-10**).
2. With the spring (13) in place, hold the V-Glide wiper switch arm shaft (17) and carrier (12) together. **See following CAUTION.**

**Wiper Switch Assembly, Continued:****CAUTION**

- **Make sure the spring is in the groove on the wiper switch. If it is not in place, the wiper switch arm may break if forced.**
3. Install the adjustment screw (14) and a new nylon lock nut (11) (**Figure 12-9, Page 12-10**). **See following NOTE.**

**NOTE:** *Wiper switch arm should be adjusted after wiper switch is fully assembled.*

4. Slide the wiper switch arm assembly into the wiper switch housing and install the bell crank with the ball stud down and away from the housing.
5. While holding the bell crank so the arm does not exert a load on the wiper switch housing, install the nut (4) and tighten to 9 ft-lb (12 N·m) (**Figure 12-9, Page 12-10**).
6. If the ball stud (5) was removed, insert it through the bell crank with the ball facing away from the wiper switch housing and install the lock nut (7). While holding the ball stud with a wrench, tighten the lock nut to 5 ft-lb (7 N·m) (**Figure 12-9, Page 12-10**).
7. Install bolt (9) with wire terminal, lock washer, and nut through switch housing.
8. Install the nut (3) onto the bolt and tighten to 40 in-lb (4.5 N·m). **See following WARNING.**

**⚠ WARNING**

- **Make sure the wiper switch arm rotates freely in the housing. If the arm binds or sticks, it must be replaced.**
9. Adjust the wiper switch. **See Wiper Switch Adjustment on page 12-9.**

**Wiper Switch Installation****⚠ CAUTION**

- **Before installing the wiper switch, inspect the housing for cracks or damage. If the housing is damaged, the entire housing with fixed contacts must be replaced.**
1. Position shim plate (29) on I-beam and then place V-Glide wiper switch assembly in position on shim plate. Install mounting bolts (26), lock washers (27), and nuts (28) (**Figure 12-9, Page 12-10**). Make sure square shoulders on the bolts fit squarely into the wiper switch housing. Tighten nuts to 36 in-lb (4.0 N·m). **See following WARNING.**

**⚠ WARNING**

- **After installing the V-Glide wiper switch, make sure it is securely fastened to the vehicle frame.**
2. Install the accelerator rod onto the ball stud.
  3. Connect 18-gauge green wire from limit switch to the small post on the solenoid that does not have the 18-gauge yellow wire attached. **See Figure 11-2, Section 11, Page 11-4.**
  4. Connect the 18-gauge black wire to black wire from charger receptacle (**Figure 12-10, Page 12-13**).

5. Connect the 6-gauge white wire from the resistor coil and the 6-gauge white wire from the solenoid to the bolt (9) in the wiper switch housing (**Figure 12-10, Page 12-13**). Install the lock washer (31) and nut (30) onto the bolt and tighten to 40 in-lb (4.5 N·m). Install cap protector (25) (**Figure 12-9, Page 12-10**).
6. Connect the 6-gauge orange wire to the fourth contact from the bottom and tighten the nut to 40 in-lb (4.5 N·m) (**Figure 12-10, Page 12-13**). **See following NOTE.**

**NOTE:** The first three contacts have NO wires attached to them.

7. Connect the 6-gauge yellow wire to the fifth contact from the bottom and tighten the nut to 40 in-lb (4.5 N·m).
8. Connect the 6-gauge green wire to the sixth contact from the bottom and tighten the nut to 40 in-lb (4.5 N·m).
9. Connect the 6-gauge blue wire to the seventh contact from the bottom and tighten nut to 40 in-lb (4.5 N·m).
10. Connect the 6-gauge black wire to the eighth contact from the bottom and tighten the nut to 40 in-lb (4.5 N·m). **See following WARNING and CAUTION.**

### **▲ WARNING**

- Make sure wires are connected to V-Glide wiper switch contacts exactly as stated. If they are not, the vehicle could start in a speed other than first.

### **CAUTION**

- Do not operate vehicle without V-Glide wiper switch cover in place. Operating vehicle without the cover allows dirt, dust, and water to contaminate wiper switch, which could cause switch to fail or malfunction.

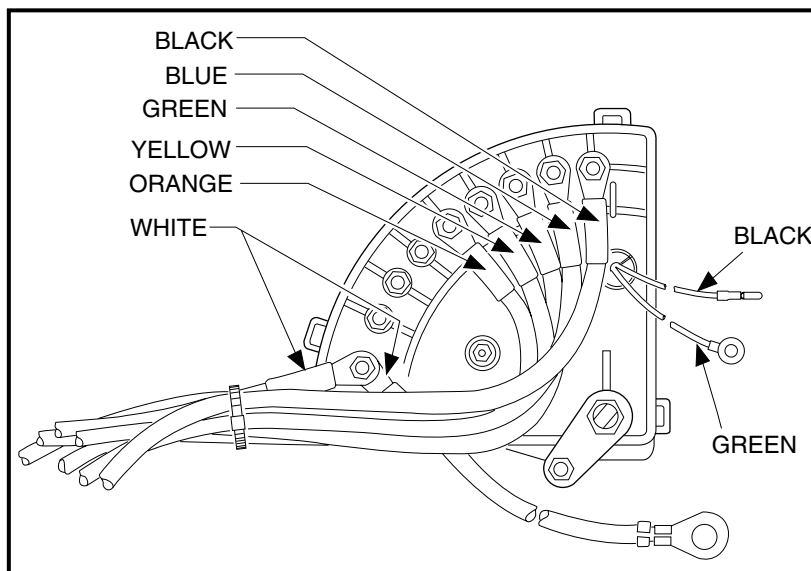

**Figure 12-10 V-Glide Wiper Switch Wires**

11. Make sure the wiper switch and pedal group are properly adjusted. **See Section 5 – Accelerator and Brake Pedal Group in the DS Golf Car Maintenance and Service Manual. See also WARNING on page 12-9.**

12. Connect the battery cables, positive (+) cable first, and tighten to 110 in-lb (12.4 N·m). Coat with Battery Terminal Protector Spray (CCI P/N 1014305) to minimize corrosion.

## FORWARD/REVERSE SWITCH

See General Warning, Section 10, Page 10-1.

The Forward/Reverse switch is mounted on the front panel of the rear body, in front of the two center batteries.

### Testing the Forward/Reverse Switch

See Test Procedure 8, Section 11, Page 11-12.

### Forward/Reverse Switch Inspection

Visually inspect the forward and reverse movable contact and stationary contacts. Make sure the stationary contacts are in good condition. If they are not, replace the entire forward and reverse assembly. If severe arcing has occurred, check the forward and reverse anti-arcing limit switch for proper operation. Keep the Forward/Reverse switch clean. If the Forward/Reverse switch is stiff or binds in operation, lubricate the contact face of the switch with WD-40<sup>®</sup> spray lubricant. See Test Procedure 8, Section 11, Page 11-12. See following WARNING.

### **⚠ WARNING**

- Do not grease contacts. This could cause the Forward/Reverse switch to malfunction or burn.

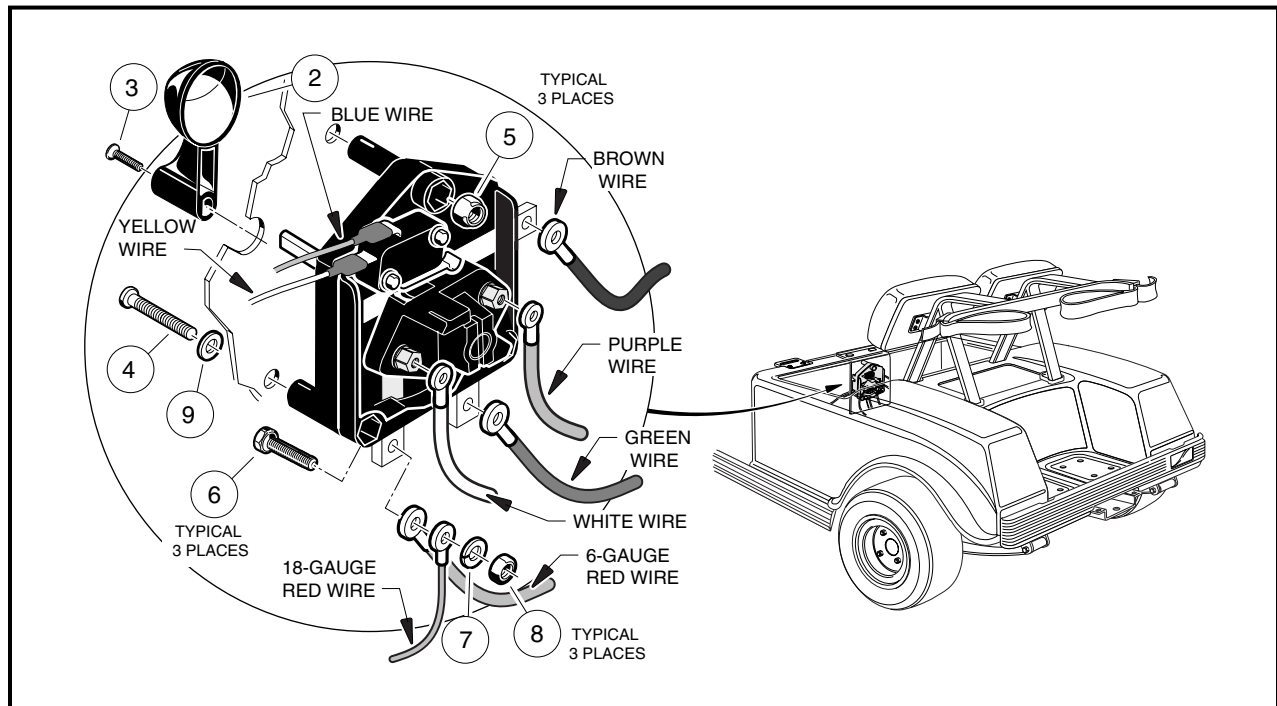

Figure 12-11 Forward/Reverse Switch

## Forward/Reverse Switch Removal

1. Disconnect the battery cables as instructed. **See WARNING “To avoid unintentionally starting...” in General Warning, Section 10, Page 10-1.**
2. Remove Forward/Reverse handle mounting screw (3) and handle (2) (**Figure 12-11, Page 12-14**).
3. Disconnect the wires from the Forward/Reverse switch.
4. Remove the screws (4), washers (9) and nuts (5) that mount Forward/Reverse switch to the body (**Figure 12-11, Page 12-14**).
5. Remove Forward/Reverse switch.

## Forward/Reverse Switch Installation

1. Connect the wires to the terminal lugs of the Forward/Reverse switch as shown (**Figure 12-11, Page 12-14**). Tighten the nuts to 45 in-lb (5.1 N·m). **See following NOTE.**

**NOTE:** Make sure the 6-gauge red and green wires are angled 45° toward the passenger side of the vehicle as shown (**Figure 12-11, Page 12-14**).

2. Secure the Forward/Reverse switch to rear body. Tighten hardware to 33 in-lb (3.3 N·m) (**Figure 12-11, Page 12-14**).
3. Connect the two 6-gauge wires to the movable contact on the back of the Forward/Reverse switch. Tighten bolts to 27 in-lb (3.0 N·m) (**Figure 12-11, Page 12-14**). **See following NOTE.**

**NOTE:** Use a 7/16-inch wrench to prevent movable contact from turning.

4. Reconnect the 18-gauge wires to the limit switch. **See following WARNING.**

### **WARNING**

- **Make sure wires are properly connected to Forward/Reverse switch. If wires are not properly connected, the vehicle may operate in an unexpected manner, resulting in property damage, severe personal injury, or death.**
5. Place handle (2) on Forward/Reverse switch. Tighten screw (3) to 14 in-lb (1.6 N·m) (**Figure 12-11, Page 12-14**).
  6. Connect the battery cables, positive (+) cable first, and tighten to 110 in-lb (12.4 N·m). Coat with Battery Terminal Protector Spray (CCI P/N 1014305) to minimize corrosion.

## CHARGER RECEPTACLE

### See General Warning, Section 10, Page 10-1.

The charger cord, plug, and receptacle are wear items and should be inspected daily. Visually inspect them for cracks, loose connections, and frayed wiring; they must be replaced when worn or damaged. If charger plug or receptacle show signs of corrosion or the plug is difficult to insert or remove, the receptacle contacts and plug terminals should be cleaned with a good electrical contact cleaner or lightly sprayed with WD-40® brand spray lubricant. The plug should then be inserted and removed several times to ensure ease of insertion, ease of removal, and good electrical contact. **See DC Cord in the appropriate battery charger maintenance and service manual for DC cord removal and installation. See following NOTE.**

**NOTE:** If the warning tag has been damaged or removed from the DC cord, have it replaced immediately.

## Testing the Charger Receptacle

Refer to the appropriate battery charger maintenance and service manual.

### Charger Receptacle Inspection

1. Inspect the receptacle for cracks, loose connections, and frayed wiring.
2. Insert the tapered end of a test blade (CCI P/N 1013930) approximately 1-1/2 inches (38 mm) into one side of the receptacle, then withdraw the blade from the contact, pulling straight out from the receptacle.
3. Repeat for the other contact. Both contacts must grip the test blade well enough to create sufficient pressure (or drag) for an adequate electrical connection. If little or no drag is felt, the receptacle must be replaced.

### Charger Receptacle Removal

1. Remove key and place Forward/Reverse handle in the NEUTRAL position. Disconnect the battery cables as instructed. **See WARNING "To avoid unintentionally starting..." in General Warning, Section 10, Page 10-1.**
2. Disconnect the small black wire (15) and the white wire (14) (to the negative battery post) from the negative terminal of the receptacle (**Figure 12-12, Page 12-16**).
3. Disconnect the red wire (11) (to the fuse link) from the positive terminal of the receptacle and remove the four screws (1) from the bezel (2) (**Figure 12-12, Page 12-16**). **See following WARNING.**

### **⚠ WARNING**

- **Make sure the black and white wires do not touch.**

4. Remove screws (3 and 18) attaching receptacle to the fuse link bracket (4).

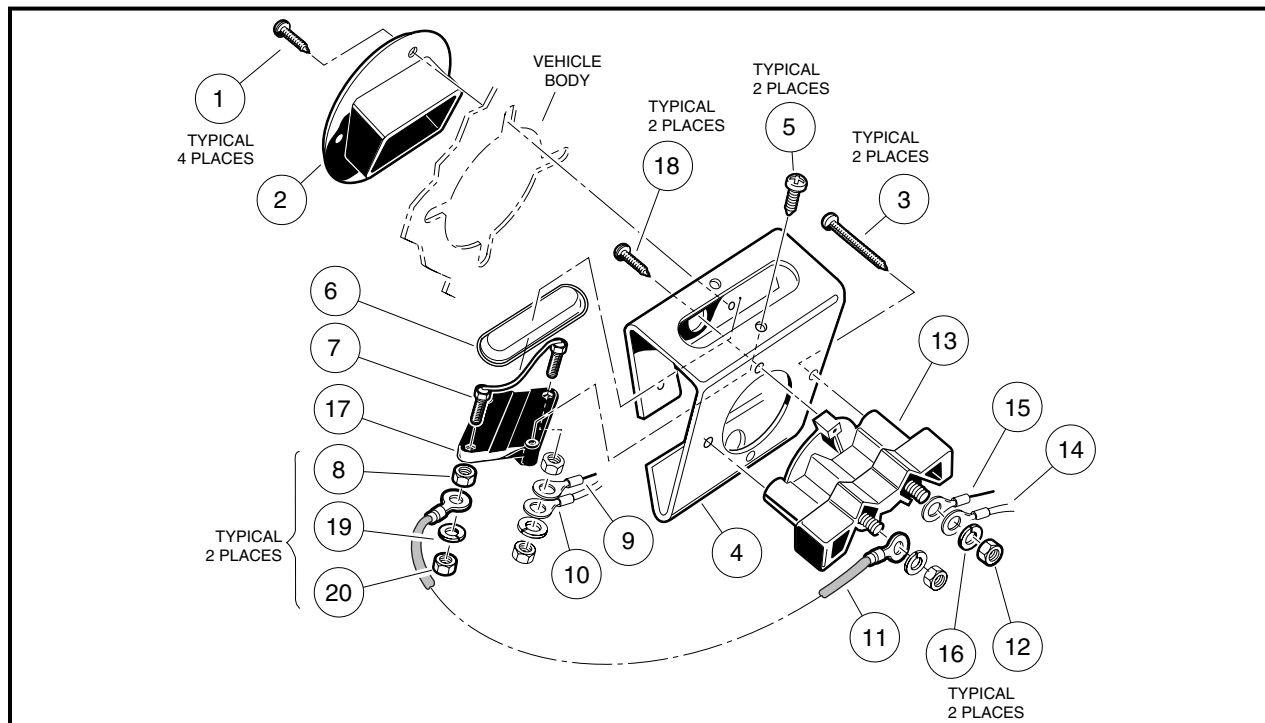

Figure 12-12 Receptacle

## Charger Receptacle Installation

1. Install the screws (3 and 18) that secure the receptacle (13) to the fuse link bracket (4) (**Figure 12-12, Page 12-16**). Tighten the screws to 20 in-lb (2.2 N·m).
2. Install red wire of fuse link to positive (+) terminal of receptacle (the positive (+) and negative (–) terminals are labeled on face of receptacle). Tighten nut to 23 in-lb (2.6 N·m).
3. Install the small black wire (from wiper switch) and the white wire (from negative battery post) on the negative (–) terminal of the receptacle. Tighten nut to 23 in-lb (2.6 N·m).
4. Position bezel (2) and fuse link bracket (4) and install the four mounting screws (1) through the bezel and into the fuse link bracket. Tighten the screws to 20 in-lb (2.2 N·m).
5. Connect the battery cables, positive (+) cable first, and tighten to 110 in-lb (12.4 N·m). Coat with Battery Terminal Protector Spray (CCI P/N 1014305) to minimize corrosion.

## RECEPTACLE FUSE LINK

If the receptacle fuse link has failed, the vehicle cannot be charged until the fuse has been replaced. The fuse link (7) is located on the fuse link bracket (4) in the battery compartment (rear portion of the charger receptacle) (**Figure 12-12, Page 12-16**). Refer to the appropriate battery charger maintenance and service manual. See following **WARNING**.

### **WARNING**

- Under normal operating conditions, the receptacle fuse link should never fail unless there is an electrical problem. If the fuse blows, determine the cause of the problem and correct it before replacing the fuse.

## Receptacle Fuse Link Removal

1. Remove the two screws (5) and then the lens (6) (**Figure 12-12, Page 12-16**).
2. Remove the outer nuts (20), lock washers (19), and wires (9, 10, and 11).
3. Remove the remaining nuts (8).
4. Remove the fuse link (7) from the base (17).

## Receptacle Fuse Link Installation

1. Install a new fuse link (7) (CCI P/N 1014516) into the base (17) (**Figure 12-12, Page 12-16**).
2. Install nuts (8) that secure fuse link to base and tighten to 18 in-lb (2.0 N·m).
3. Connect the red wire (9) (from the forward and reverse switch) and the orange wire (10) (from the reverse buzzer) to the passenger side of the fuse assembly and install the lock washer (19) and outer nut (20). Tighten the nut to 23 in-lb (2.5 N·m) (**Figure 12-12, Page 12-16**). Refer to the appropriate battery charger maintenance and service manual.
4. Connect the red wire (11) (from the charger receptacle) to the driver side of the fuse assembly and install the lock washer (19) and nut (20). Tighten the nut to 23 in-lb (2.5 N·m).
5. Install fuse link assembly and cover (6). Tighten screws (5) to 20 in-lb (2.2 N·m).





## SECTION 13 – BATTERIES

---

### **▲ DANGER**

- See General Warning, Section 10, Page 10-1.

### **▲ WARNING**

- See General Warning, Section 10, Page 10-1.

## GENERAL INFORMATION

---

The batteries supplied with an electric Club Car vehicle are different from those supplied with an automobile. The outward appearances of these two types of batteries are similar, but the operating characteristics are very different. The Club Car electric vehicle battery is a deep-cycle battery, and the automotive battery is a “starting, lighting and ignition” (SLI) battery. They should never be substituted for one another.

An automotive battery has to deliver high-cranking currents of 300-400 amperes at a sufficient voltage for several seconds and maintain an accessory load of 10-25 amperes in stop-and-go driving. The energy removed from an automotive battery is immediately replaced by the alternator or generator. As a result, the automotive battery operates at 90 to 100% of full charge at all times.

The batteries supplied with an electric vehicle must supply 100% of the energy required to operate the vehicle. These batteries therefore, receive a deep discharge down to 30% to 40% of their full charge capacity. Then they must be recharged, hence the name “deep cycle.” The average amperage draw is considered to be 75 amps on a 36-volt vehicle, although it varies greatly depending on the vehicle and how it is operated. Deep-cycle vehicle batteries are specifically designed to handle this type of service.

The rechargeable lead-acid battery turns chemical energy into electrical energy and vice versa. The main active elements within a battery are the positive plates, the negative plates and the electrolyte (sulfuric acid). Another very important element (but inactive) is the separator. The separator does exactly what its name implies – it separates the material of the positive and negative plates and prevents them from touching each other, which would create electrical short circuits. The separator is porous enough to allow charged ions to pass between the positive and negative plates, but not allow the two materials to contact each other.

Whenever two unlike metals are immersed in an acid solution, an electric current is generated. In a deep-cycle battery, the negative plates contain lead (Pb) and the positive plates contain lead dioxide (PbO<sub>2</sub>). These plates are immersed in a sulfuric acid solution (H<sub>2</sub>SO<sub>4</sub>) (**Figure 13-1, Page 13-2**).

During discharge, the chemical reaction inside the battery causes the sulfate (SO<sub>4</sub>) to break away from the H<sub>2</sub> (**Figure 13-2, Page 13-2**).

The sulfate (SO<sub>4</sub>) combines with the lead (Pb) on both plates, forming lead sulfate (PbSO<sub>4</sub>). Oxygen (O<sub>2</sub>) from the positive plates combines with hydrogen (H) from the electrolyte to form water (H<sub>2</sub>O) (**Figure 13-3, Page 13-2**).

## General Information, Continued:

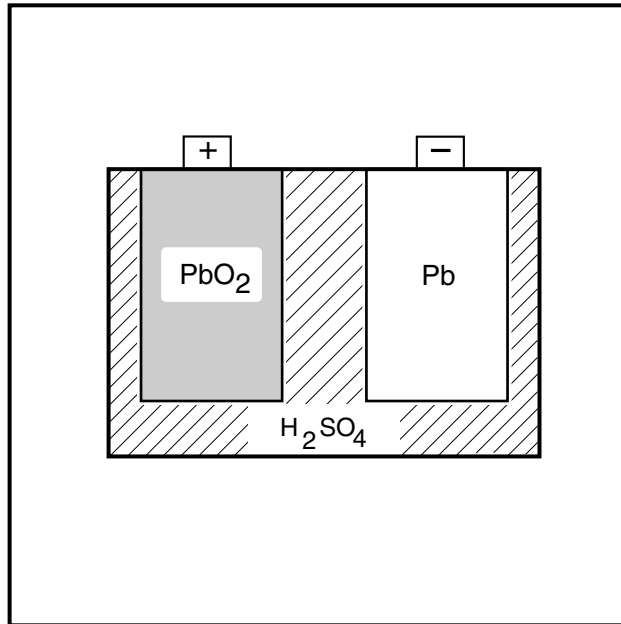

Figure 13-1 Charged Battery

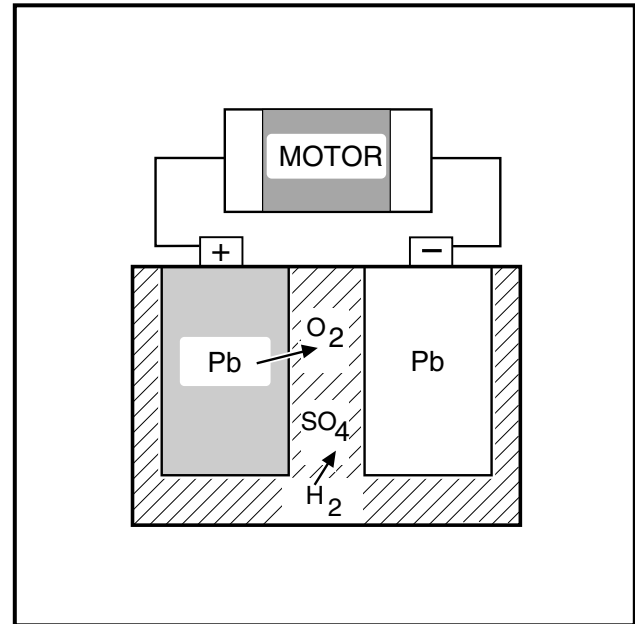

Figure 13-2 Discharging Battery

The result is two similar metals, lead sulfate ( $\text{PbSO}_4$ ) immersed in water ( $\text{H}_2\text{O}$ ). This will not generate electricity because the battery is completely discharged.

When a discharged battery is connected to a charger, the process is reversed. The sulfate ( $\text{SO}_4$ ) is forced from the plates back into the electrolyte to make sulfuric acid ( $\text{H}_2\text{SO}_4$ ). The oxygen returns to the positive plate to make lead dioxide ( $\text{PbO}_2$ ) (**Figure 13-4, Page 13-2**).

The result is a charged battery that is again capable of generating electricity (**Figure 13-1, Page 13-2**).

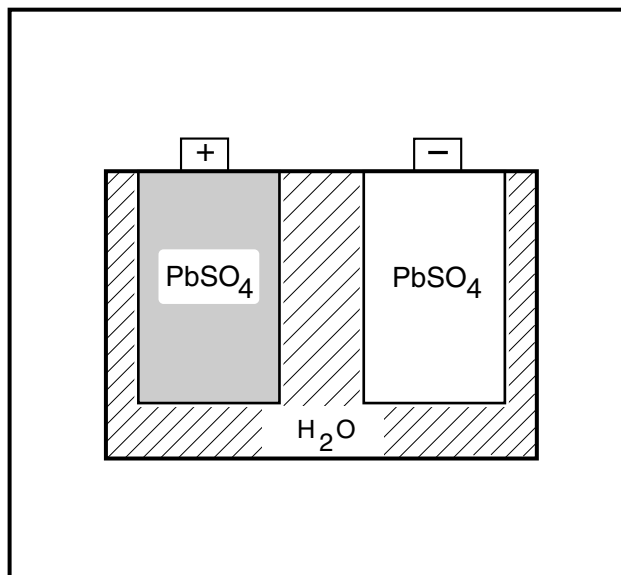

Figure 13-3 Discharged Battery

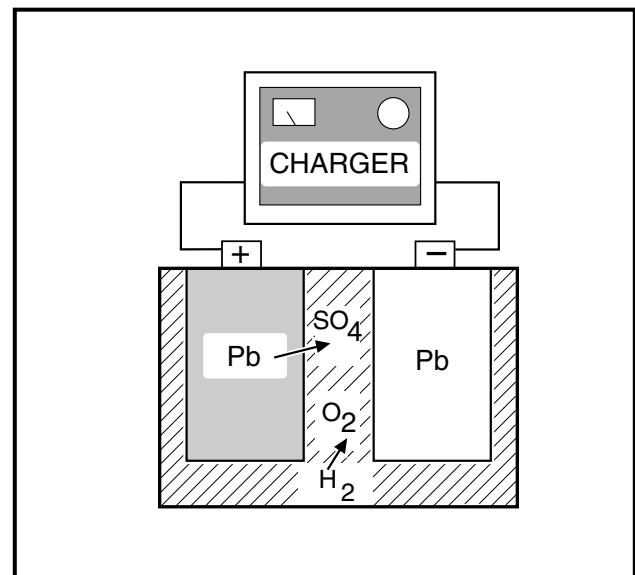

Figure 13-4 Battery Charging

## COMMON MISCONCEPTIONS ABOUT BATTERIES

The chart below describes some of the more common misconceptions that are associated with deep-cycle vehicle batteries and battery care.

PROBLEM	MISCONCEPTION	REALITY
Deep-discharge	"This vehicle is running slowly, but we can run it until it stops."	Avoid deep discharge of batteries whenever possible. <b>See Deep-Discharge on page 13-7.</b>
Early excessive discharging	"These are new batteries. They can run all day."	New batteries do not reach their full capacity until they have been used and recharged 20 to 50 times. <b>See Early Excessive Discharging on page 13-7.</b>
Mineral content	"Tap water will do for our batteries."	Your tap water might be OK, but have it checked first. <b>See Mineral Content on page 13-6.</b>
Self-discharge	"Dirt and corrosion on the battery won't hurt anything."	Dirt and corrosion might provide a path for current to flow and allow the batteries to self-discharge. <b>See Self-Discharge on page 13-5.</b>
Over watering	"Batteries can be filled to the level indicator at night, so it won't have to be done in the morning."	Under most circumstances, water should be added after charging. <b>See Electrolyte Level on page 13-5.</b>
Under watering	"Checking the water takes too much time; it can be checked once a month."	Insufficient watering can ruin batteries. Water level should be checked weekly. <b>See Electrolyte Level on page 13-5.</b>
Vibration damage	"You should tighten battery hold-downs as tight as you can."	Battery hold-downs should be tightened to specification. Hold-downs that are too tight or too loose can cause battery damage. <b>See Vibration Damage on page 13-6.</b>

## BATTERY REPLACEMENT

See General Warning, Section 10, Page 10-1.

### WARNING

- To prevent electrolyte leakage from the battery vents, batteries must be kept in an upright position. Tipping a battery beyond a 45° angle in any direction can allow a small amount of electrolyte to leak out the vent hole. Do not exceed this 45° angle when lifting, carrying, or installing batteries. Battery acid can cause severe personal injury to skin or eyes, and can damage clothing.
1. Before removing batteries, note the orientation of the batteries and the connecting wires. Disconnect the battery cables as instructed. **See WARNING "To avoid unintentionally starting..." in General Warning, Section 10, Page 10-1.** Remove remaining wires and batteries. **See Wiring Diagram, Section 11, Page 11-4.**
  2. Visually inspect the new batteries for any damage that may have occurred in transit.

**Battery Replacement, Continued:**

3. If the battery cables are to be reused, inspect them for broken or frayed wires, damaged terminals, or worn insulation. Remove any corrosion on the connectors. A solution of baking soda and water (1 cup (237 mL) baking soda per 1 gallon (3.8 L) of water) does an excellent job of neutralizing and removing the corrosion. Be careful not to allow the baking soda solution to enter the battery.

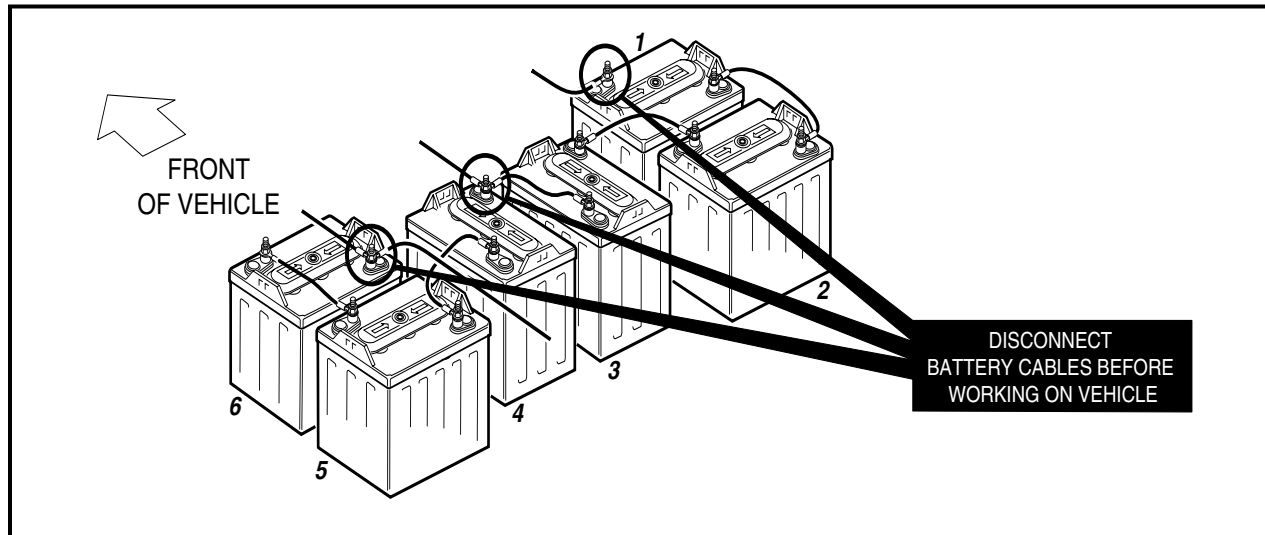

**Figure 13-5 V-Glide 36-volt Battery Configuration**

4. Check and clean the battery rack and hold-downs. The nuts and bolts on the hold-downs may corrode. It is therefore advised they be cleaned periodically and replaced as necessary.
5. Install batteries in the proper orientation (**Figure 13-5, Page 13-4**). Install battery hold-downs. The hold-downs should be tight enough so batteries do not move while vehicle is in motion, but not so tight as to crack or buckle battery case. Tighten to 40 in-lb (4.5 N·m), alternating between hold-down bolts.
6. Install wires in proper sequence (**Figure 13-5, Page 13-4**). Install black wire to negative (–) post of battery no. 6 last. Make sure all connections are tight. Tighten to 110 in-lb (12.4 N·m). Coat all terminals with Battery Terminal Protector Spray (CCI P/N 1014305) to minimize future corrosion.
7. Give the batteries a full charge prior to operation. This ensures all the batteries are fully charged and the cells are equalized prior to use.

## BATTERY CARE

See General Warning, Section 10, Page 10-1.

### PREVENTIVE MAINTENANCE

To keep batteries in sound operating condition, follow these steps on a regular basis.

1. Any corrosion build-up on or around batteries should be removed immediately. Terminal connections should be clean and tight. Any frayed or worn wires should be replaced. After all cables have been connected, coat all terminals with Battery Terminal Protector Spray (CCI P/N 1014305) to help prevent future corrosion.

2. Batteries should be clean and free of corrosion. Wash tops and terminals of batteries with a solution of baking soda and water (1 cup (237 mL) baking soda per gallon (3.8 L) of water). Rinse solution off batteries. Do not allow this solution to enter the batteries. Be sure terminals are tight. Let the terminals dry and then coat them with Battery Terminal Protector Spray (CCI P/N 1014305). **See Self-Discharge on page 13-5.**
3. Maintain proper electrolyte level. **See Electrolyte Level on page 13-5.**
4. Batteries should be properly charged every day they are used. Check the batteries periodically to see that they are in a full state of charge. **See Battery Charging on page 13-6.**
5. Keep hold-downs tight. **See Vibration Damage on page 13-6.**

## SELF-DISCHARGE

Contaminants on dirty batteries can provide a path for a small current draw that can slowly discharge batteries, thus wasting valuable energy. To prevent self-discharge, batteries should always be kept clean.

Hot weather also has an effect on a battery's self-discharge rate. The higher the temperature, the quicker a set of batteries will discharge. In hotter climates, batteries should be checked more often. When storing batteries, keep in a cool place. **See Battery Storage on page 13-14.**

## ELECTROLYTE LEVEL

### CAUTION

- **Do not allow battery acid from battery caps or hydrometer to drip onto the front or rear body of the vehicle. Battery acid will cause permanent damage. Wash immediately.**

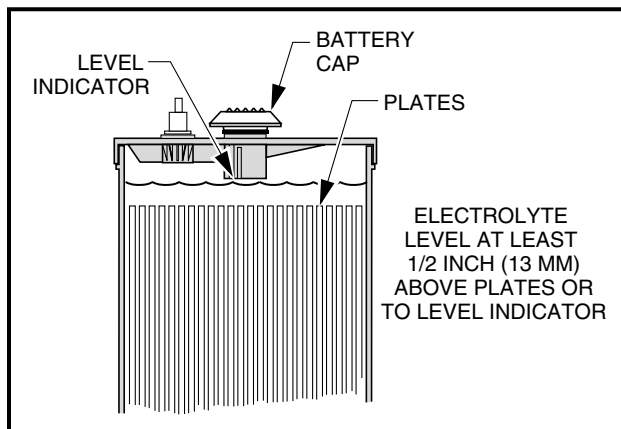

**Figure 13-6 Battery Electrolyte Level**

Add water only after charging unless the electrolyte is below the level of the plates. If the electrolyte level is below the level of the plates, add just enough water to cover the plates and then charge the batteries. After charging, fill with water to the level indicator. Filling a battery to the level indicator before charging will result in overfilling because the electrolyte level will rise during charging and some of the electrolyte may bubble out of the cap. This reduces the battery's capacity and corrodes the metal parts around it.

**Electrolyte Level, Continued:**

The electrolyte level should be checked weekly to be sure electrolyte is at its proper level (**Figure 13-6, Page 13-5**). Never allow the electrolyte level to fall below the tops of the plates because this will cause the exposed part of the plate to become permanently inactive. For best results, use a battery watering gun to add water to batteries. Check the electrolyte level more frequently in hot weather or when batteries are old.

**Mineral Content**

For the longest battery life, use distilled water in batteries. However, if tap water is to be used, be sure the mineral contents are below these levels:

IMPURITY	ALLOWABLE CONTENT (PARTS PER MILLION)
Suspended matter	Trace
Total solids	100.0
Calcium and Magnesium Oxides	40.0
Iron	5.0
Ammonia	8.0
Organic matter	50.0
Nitrates	10.0
Nitrites	5.0
Chloride	5.0

**VIBRATION DAMAGE**

The battery hold-downs should always be tight enough to keep the battery from bouncing. Battery life may be severely shortened if the battery hold-downs are too loose. Battery hold-downs should be tightened to 40 in-lb (4.5 N-m). Excessive vibration causes the plates to shed prematurely and shortens the life of the battery. It may also cause acid to leak out of the vent caps and corrosion to build up on surrounding metal parts. The acid which is lost reduces the capacity of the battery and cannot be replaced. Battery hold-downs should NOT be so tight as to crack or buckle the battery case. This may cause leaks, which would dry out a cell or cause internal short circuits. **See Battery Replacement on page 13-3.**

**BATTERY CHARGING****See General Warning, Section 10, Page 10-1.**

The charger supplied with the Club Car electric vehicle resolves the most common problems associated with battery charging. Undercharging and overcharging are prevented provided the charger is allowed to shut off by itself. Also, all cells are automatically given an equalization charge at low current, which prolongs battery life. Batteries should never be left in a discharged state, as this too affects the internal components and can reduce the capacity of the battery. The batteries should be charged every day they are used. However, the batteries should not be charged if they have not been used.

## CHARGER DOES NOT SHUT OFF AUTOMATICALLY

This may be due to 1) new batteries, 2) hard use, or 3) cold temperatures. A catch-up charge may be necessary when these conditions are present. On those days when all or some of the vehicles do not get used, check the batteries for state of charge. Any battery with a specific gravity lower than 1.250 will need a catch-up charge. If the problem continues after a catch-up charge has been performed, check the battery charger. **See the appropriate battery charger maintenance and service manual.**

## DEEP-DISCHARGE

Never discharge batteries to the point the vehicle will no longer operate. This will considerably shorten the cycle life of the batteries, and may permanently damage the batteries. It is possible the batteries will not accept a charge if they are completely discharged. The deeper the discharge, the harder it is on the batteries. For this reason, it is recommended that Club Car electric vehicle batteries be charged after each use (provided the charge cycle will not be interrupted and the charger will be allowed to shut off automatically). Placing the batteries on charge after each use reduces the depth of discharge and prolongs battery life.

## EARLY EXCESSIVE DISCHARGING

When vehicle batteries are new, they do not reach their full capacity until they have been used and recharged 20 to 50 times. If they are excessively discharged early in their life, their effective service life will be shortened. It is advisable to limit the use of any vehicle with new batteries for at least the first four weeks and then gradually increase their range.

## INCOMING AC SERVICE

Make sure the incoming AC line service is sufficient. If circuit breakers are tripping, fuses blow during the night or the charger does not give the required starting rate when sound batteries are put on charge, an AC line problem exists. The electrical service to the vehicle storage facility should be sufficient to deliver adequate voltage and current to each charger with all the chargers turned on. If not, consult your local power company or electrical contractor. **See the appropriate battery charger maintenance and service manual.**

## FLEET ROTATION

Rotate vehicle usage. It is very hard on batteries if the last vehicles in at night are the first ones out in the morning. Spread the workload evenly, giving all vehicles the same amount of use. This will keep your fleet in balance and will not overwork certain sets of batteries.

## NUMBERING VEHICLES AND CHARGERS

Return the vehicles to the same charger each night if possible. If the vehicles are put in a storage facility at random and a vehicle dies while in use and testing shows the batteries are sound, then the problem is most likely with the charger. However, finding the problem charger may prove to be quite time consuming. Numbering the vehicles and the chargers and returning each vehicle to its designated charger each night can significantly reduce the amount of time spent troubleshooting a problem.

**BATTERY TROUBLESHOOTING CHART**

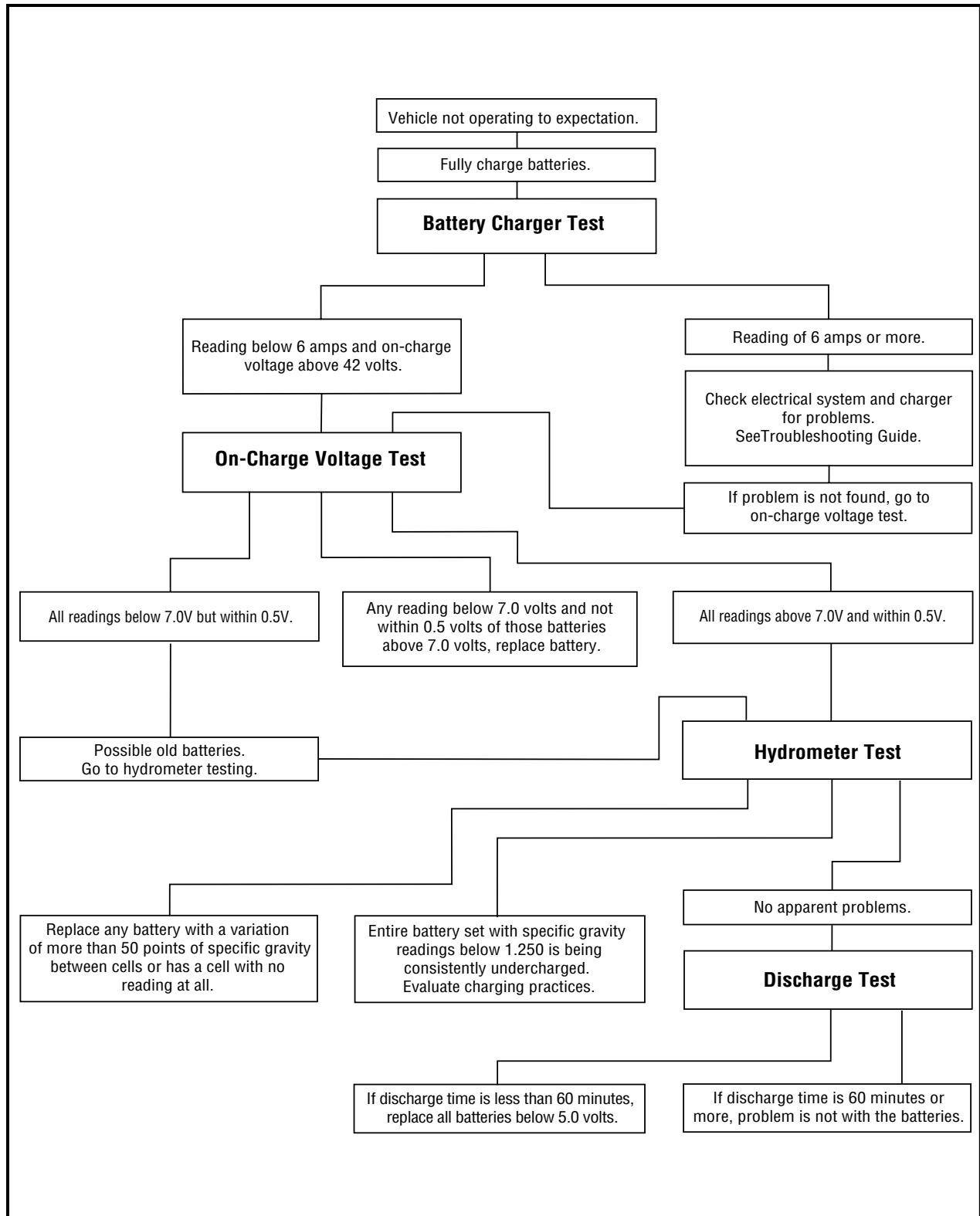

Figure 13-7 Battery Troubleshooting Chart



## BATTERY TESTING

---

### See General Warning, Section 10, Page 10-1.

Four tests have been developed to help diagnose problems with batteries that have not performed as expected. Because each test becomes progressively more detailed and time-consuming, begin with the first test and follow through with the other tests until the problem has been identified as outlined in the Battery Troubleshooting Chart (**Figure 13-7, Page 13-8**).

### BATTERY CHARGER TEST

The easiest way to monitor the condition of a vehicle's batteries is simply to observe the reading on the battery charger ammeter at the end of the charge cycle. After a full charge, disconnect the charger DC plug, wait 20 to 30 seconds and reconnect the charger DC plug. The ammeter needle will jump to 15 amps or more and then taper to below 6 amps within 10 to 20 minutes, indicating sound, fully charged batteries.

Continued poor performance may indicate a problem in the vehicle electrical system, brakes, or battery charger. If the problem is not found in the vehicle or charging system, proceed to the on-charge voltage test. Batteries that remain at 8 amps or higher should be tested further using the on-charge voltage test.

### ON-CHARGE VOLTAGE TEST

When the batteries are fully charged, disconnect the charger DC plug. Wait 20 to 30 seconds and reconnect the DC plug to restart the charger. After 5 minutes, use a multimeter to check and record the voltage of the battery set as well as the individual batteries. Set the multimeter to 200 volts DC. Place the red (+) probe on the positive (+) post of battery no. 1 and the black (-) probe on the negative (-) post of battery no. 6 (**Figure 13-5, Page 13-4**). Record reading. Then set multimeter to 20 volts DC and place the red (+) probe on the positive (+) post and the black (-) probe on the negative (-) post of each battery. Record the readings.

The on-charge voltage for the set should be between 42.0 volts and 47.4 volts depending on the age and state of charge of the batteries being tested. If individual batteries read above 7.0 volts and are within 0.5 volts of each other, go to the hydrometer test. If any battery reads below 7.0 volts and not within 0.5 volts of those batteries above 7.0 volts, replace battery. If readings are below 7.4 volts but within 0.5 volts of each other, the batteries are old. Old batteries may have enough capacity left to last several more months. Go to hydrometer test. **See Battery Troubleshooting Chart on page 13-8 and the examples on the following pages.**

### HYDROMETER TEST

A hydrometer measures the specific gravity of the battery's electrolyte. The higher the specific gravity, the higher the state of charge of the batteries. A fully charged battery should read between 1.250 and 1.280 at 80 °F (26.7 °C). Never add acid to batteries to obtain a higher specific gravity.

#### Performing the Hydrometer Test

1. Be sure batteries have sufficient electrolyte to cover plates by approximately 1/2 inch (13 mm) and are fully charged prior to beginning test. If water must be added, recharge the batteries before performing the hydrometer test.
2. Remove the vent cap. Using a battery thermometer (CCI P/N 1011767), record electrolyte temperature of the no. 2 cell.
3. Squeeze the rubber bulb of the hydrometer and insert into the cell. Slowly release the bulb, drawing electrolyte up into the glass tube of the hydrometer.
4. When the float rises off the bottom, adjust the electrolyte level so that the float rides free of the bottom but does not strike the top of the glass tube. Remove the hydrometer from the cell and release the pressure from the bulb.

**Performing the Hydrometer Test, Continued:**

5. Hold the hydrometer vertically, ensuring that the float is not touching the sides of the barrel. Hold the hydrometer at eye level and read the scale at the level of electrolyte (**Figure 13-8, Page 13-10**).
6. Record the reading and return the electrolyte to the cell from which it was taken. Replace vent cap.
7. Repeat steps 2 through 6 on all cells.

**Hydrometer Calibration**

Most hydrometers are calibrated to read correctly at 80 °F (26.7 °C). The readings obtained as described above must be corrected for temperature. For each 10 °F (5.6 °C) above 80 °F (26.7 °C), add 0.004 to the reading. For each 10 °F (5.6 °C) below 80 °F (26.7 °C), subtract 0.004 from the reading.

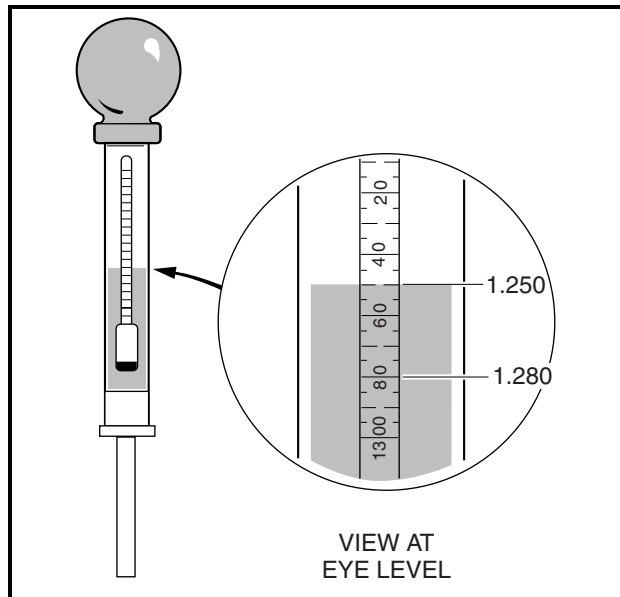

**Figure 13-8 Hydrometer**

**Interpreting the Results of the Hydrometer Test**

The approximate state of charge can be determined from the following table:

SPECIFIC GRAVITY (TEMPERATURE CORRECTED)	APPROXIMATE STATE OF CHARGE
1.250-1.280	100%
1.220-1.240	75%
1.190-1.210	50%
1.160-1.180	25%

If the difference between the cells is 0.020 or more, the low cell should be suspected. It may require a catch-up charge or it may be a weak cell. When the variations between cells reach 0.050 or more, the battery with the low cell should be replaced.

VEHICLE NO.	BATTERY NO.	ELECTROLYTE TEMPERATURE	CORRECTION FACTOR	CORRECTED SPECIFIC GRAVITY			REQUIRED ACTION
				POSITIVE CELL	CENTER CELL	NEGATIVE CELL	
12	1	20 °F (-6.6 °C)	- 0.024	1.275 - 0.024 = 1.251	1.280 - 0.024 = 1.256	1.280 - 0.024 = 1.256	Sound battery - fully charged
35	6	90 °F (32.2 °C)	+ 0.004	1.155 + 0.004 = 1.159	1.165 + 0.004 = 1.169	1.160 + 0.004 = 1.164	Discharged battery - recharge
54	3	50 °F (10 °C)	- 0.012	1.260 - 0.012 = 1.248	1.200 - 0.012 = 1.188	1.270 - 0.012 = 1.258	Bad center cell
69	5	80 °F (26.7 °C)	0.000	1.250 - 0 = 1.250	1.255 - 0 = 1.255	1.230 - 0 = 1.230	Weak negative cell - catch-up charge
38	2	100 °F (37.8 °C)	+ 0.008	1.200 + 0.008 = 1.208	1.180 + 0.008 = 1.188	1.170 + 0.008 = 1.178	Discharged battery - recharge and recheck
22	4	80 °F (26.7 °C)	0.000	1.240 - 0 = 1.240	1.245 - 0 = 1.245	Float does not rise	Negative cell dead - replace battery

## DISCHARGE TEST

If the previous tests have failed to identify the problem, conduct a discharge test. The discharge test comes closest to simulating actual vehicle operating conditions by continuously drawing current from the batteries until voltage drops to 31.5 volts.

The discharge test is the hardest test on the batteries and the most time-consuming to perform. Use the battery discharge tester (CCI P/N 101831901).

### Performing the Discharge Test

1. Be sure the batteries are fully charged and that the electrolyte level is correct in all cells.
2. Connect the tester probes to the positive (+) post of battery no.1 and negative (-) post of battery no. 6 (Figure 13-9, Page 13-11).

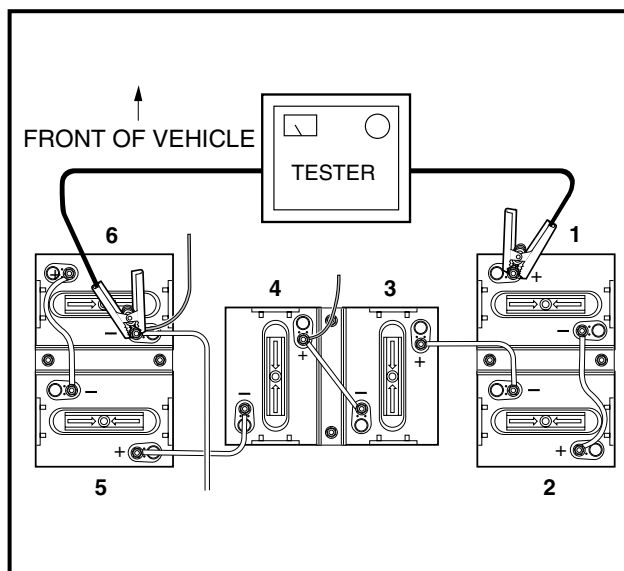

Figure 13-9 Battery Discharge Test

**Performing the Discharge Test, Continued:**

3. Check and record the electrolyte temperature of the battery packs. Check center cell of each battery.
4. Reset discharge machine (or reset timer if using older discharge machine with 36-volt vehicle).
5. Turn the tester ON.
6. When the batteries have been discharging for approximately 60 minutes, set the discharge machine to function 3 and check battery set voltage. Check voltage every 10 minutes throughout the rest of the test. As soon as the battery set voltage reaches 0.50 volts above the shut-off point (31.5 volts), use a multi-meter to measure individual battery voltages. Measure and record the voltage of each battery to the nearest 0.01 volt. **See following NOTE.**

**NOTE:** The tester will shut off automatically when shut-off voltage is reached.

**Interpreting Discharge Test Results**

1. If discharge time is 60 minutes or higher, the problem is not with the batteries.
2. If discharge times are low (less than 60 minutes), replace batteries below 5.0 volts.

BATTERY VOLTAGES						BATTERY CONDITION
1	2	3	4	5	6	
5.25 V	5.25 V	5.25 V	5.25 V	5.25 V	5.25 V	Excellent
5.3 V	5.3 V	5.4 V	4.9 V	5.3 V	5.3 V	Battery no. 4 is near end of useful life
5.4 V	5.4 V	5.0 V	5.5 V	4.7 V	5.5 V	Battery nos. 3 and 5 are near end of useful life

3. In general, battery sets that discharge in less than 60 minutes at 78 °F (25.6 °C) on the discharge test will typically not hold a charge for an entire work shift. However, discharge time is dependent on the electrolyte temperature. The table shown gives the discharge times, at various temperatures, of a set of batteries that delivers 62 minutes at 80 °F (26.7 °C).

ELECTROLYTE TEMPERATURE	DISCHARGE TIME TO SHUT-OFF POINT	ELECTROLYTE TEMPERATURE	DISCHARGE TIME TO SHUT-OFF POINT
40-49 °F (4-9 °C)	40 Minutes	85-89 °F (29-32 °C)	64 Minutes
50-59 °F (10-15 °C)	45 Minutes	89-99 °F (32-37 °C)	66 Minutes
60-64 °F (16-18 °C)	50 Minutes	100-109 °F (38-43 °C)	68 Minutes
65-69 °F (18-21 °C)	54 Minutes	110-119 °F (43-48 °C)	70 Minutes
70-74 °F (21-23 °C)	57 Minutes	120-129 °F (49-54 °C)	72 Minutes
75-79 °F (24-26 °C)	60 Minutes	130-150 °F (54-66 °C)	74 Minutes
80-84 °F (27-29 °C)	62 Minutes	*****	*****

## BATTERY TROUBLESHOOTING EXAMPLES

The following information represents a few examples of troubleshooting battery problems.

### Example 1

Vehicle no. 68 was suspected of having a bad battery due to its performance. As a result, the battery charger test was performed. After a full charge, the battery charger ammeter read 8.0 amps. Next, the on-charge voltage test was performed and the following results were recorded:

BATTERY NO.	1	2	3	4	5	6
On-Charge Voltage	7.61 V	7.95 V	7.36* V	7.62 V	7.92 V	7.96 V

\*Battery no. 3 appears suspect. Battery nos. 1 and 4 are also suspect. Next, a hydrometer test should be conducted on all batteries.

### Hydrometer test results:

BATTERY NO.	1	2	3	4	5	6
Positive Post Cell	1.200*	1.265	1.300	1.250	1.280	1.260
Center Cell	1.285	1.275	1.290	1.270	1.295	1.265
Negative Post Cell	1.265	1.270	1.285	1.265	1.275	1.275

\*After the hydrometer test, it appears that battery no. 1 is the problem. Next, the discharge test was performed.

### Discharge test results:

BATTERY NO.	1	2	3	4	5	6
Discharge Voltage	4.08 V	5.50 V	5.80 V	5.36 V	5.57 V	5.56 V

\*After a discharge test which lasted 45 minutes, battery no. 1 is clearly shown to be the problem. Battery no. 4 should be watched a little more closely but appears to be okay. Battery no. 1 should be replaced with a battery that has about the same age and usage as the other batteries in the set.

### Example 2

Vehicle no. 70 was also suspected of having a bad battery due to its performance. The battery charger test showed 7.0 amps after a full charge. After confirming there were no problems with the electrical system, charger or brakes, the on-charge voltage was recorded as follows:

BATTERY NO.	1	2	3	4	5	6
On-charge Voltage	7.86 V	7.33 V	7.90 V	7.93 V	7.91 V	7.75 V

\*Battery no. 2 was immediately suspected as the problem. After checking battery no. 2 with a hydrometer, it was discovered that the negative (–) post cell was completely dead. Battery no. 2 should be replaced with a battery that has the same age and usage as the other batteries in the set.

## BATTERY STORAGE

---

### See General Warning, Section 10, Page 10-1.

When storing batteries during the off-season or when maintaining a replacement stock, follow these guidelines.

1. Keep the batteries clean and free of corrosion. **See Battery Care on page 13-4.**
2. Batteries can be left connected for winter storage.
3. Store in a cool, dry place. The colder the area in which the batteries are stored, the less the batteries will self-discharge. Batteries stored at 0 °F (-17.8 °C) will discharge very little over a four-month period. Batteries stored at 80 °F (26.7 °C) will have to be recharged every few weeks.
4. Check the state of charge periodically. Batteries that are discharged and left in a cold environment can freeze and crack. If the specific gravity drops below 1.220, the batteries should be recharged. **See the following chart.**

SPECIFIC GRAVITY (TEMPERATURE CORRECTED)	APPROXIMATE STATE OF CHARGE
1.250-1.280	100%
1.220-1.240	75%
1.190-1.210	50%
1.160-1.180	25%

5. The frequency of recharging required will depend on the temperature of the storage area, but it is recommended the batteries be monitored for state of charge every month. Also, if the storage area is unheated in a cold climate and recharge is required, it is recommended the area be heated to at least 60 °F (15.6 °C) prior to charge. Batteries do not charge effectively in cold temperatures for the same reasons they do not discharge as rapidly in cold temperatures.

## CHARGING A BATTERY PACK THAT HAS LOW VOLTAGE

---

See the appropriate battery charger maintenance and service manual.

## SECTION 14 – BATTERY CHARGER

---

Refer to the appropriate battery charger maintenance and service manual.





# SECTION 15 – MOTOR

---

## **⚠ DANGER**

- See General Warning, Section 10, Page 10-1.

## **⚠ WARNING**

- See General Warning, Section 10, Page 10-1.

## GENERAL INFORMATION

---

All DS V-Glide electric vehicles are equipped with 36-volt DC, series wound, reversible traction motors. If the motor should require major repair, it should be sent to a qualified motor repair shop; however, there are many minor repairs that can be made by a trained technician.

## EXTERNAL MOTOR TESTING

---

The following tests can be performed using a multimeter or continuity tester without disassembling the motor. See following NOTE.

*NOTE: Tag the motor wires for identification before disconnecting.*

### TEST PROCEDURE 1 – INTERNAL SHORT CIRCUITS

See General Warning, Section 10, Page 10-1.

1. Disconnect the battery cables as instructed. See WARNING “To avoid unintentionally starting...” in General Warning, Section 10, Page 10-1.
2. Disconnect wires from terminals on motor using two wrenches to prevent the post from turning.
3. Set a multimeter to 200  $\Omega$  (ohms) and place the black (–) probe on the motor housing. Scratch through the paint to ensure a good connection. Place the red (+) probe on the A1, A2, S1, and S2 terminals respectively (Figure 15-1, Page 15-2). Multimeter should indicate no continuity. If the readings are incorrect, the motor will need to be removed from the vehicle and repaired by a qualified technician. See Motor Removal on page 15-3.
  - 3.1. An incorrect reading from the A1 or A2 terminal indicates three possible problems: a grounded A1 or A2 terminal, a grounded wire in the brush area, or a grounded armature/commutator. An incorrect reading for the S1 or S2 terminal indicates a possible grounded S1 or S2 terminal or field coil.

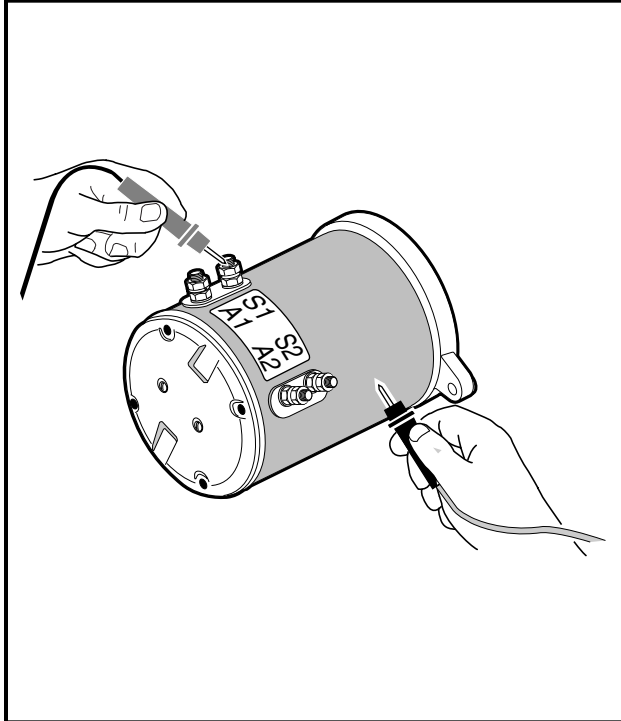

Figure 15-1 Motor Short Circuit Test

## TEST PROCEDURE 2 – ARMATURE CIRCUIT OPEN

See General Warning, Section 10, Page 10-1.

1. Disconnect the battery cables as instructed. See **WARNING “To avoid unintentionally starting...”** in **General Warning, Section 10, Page 10-1.**
2. Disconnect the wires from the A1 and A2 terminals on the motor using two wrenches to prevent the posts from turning. Set a multimeter to 200  $\Omega$  (ohms) and place the red (+) probe on the A1 terminal and the black (-) probe on the A2 terminal. The multimeter should indicate continuity. If the reading is incorrect, a possible open or poor contact in a brush assembly and/or open armature windings may be the cause. The motor will need to be removed from the vehicle and repaired by a qualified technician. See **Motor Removal on page 15-3.**

## TEST PROCEDURE 3 – FIELD CIRCUIT OPEN

See General Warning, Section 10, Page 10-1.

1. Disconnect the battery cables as instructed. See **WARNING “To avoid unintentionally starting...”** in **General Warning, Section 10, Page 10-1.**
2. Disconnect the wires from the motor S1 and S2 terminals using two wrenches to prevent the posts from turning. Set a multimeter to 200  $\Omega$  (ohms) and place the red (+) probe on the S1 terminal and the black (-) probe on the S2 terminal. The multimeter should indicate continuity. If the reading is incorrect, a possible open field coil or bad connections at the terminals may be the cause. The motor will need to be removed from the vehicle and repaired by a qualified technician. See **Motor Removal on page 15-3.**

## MOTOR

See General Warning, Section 10, Page 10-1.

### Motor Removal

1. Disconnect the battery cables as instructed. See **WARNING “To avoid unintentionally starting...”** in **General Warning, Section 10, Page 10-1.**
2. Disconnect wires from terminals on motor using two wrenches to prevent the posts from turning. Label the wires to ensure proper reconnection.
3. Slightly loosen all the lug nuts on both rear wheels.
4. Place floor jack under transaxle and raise rear of vehicle (**Figure 15-2, Page 15-3**) then place jack stands under frame crossmember between the spring mount and the side stringer, just forward of each rear wheel. Lower the vehicle to let the jack stands support the vehicle (**Figure 15-3, Page 15-3**). See following **WARNING**.

### **▲** WARNING

- Lift only one end of the vehicle at a time. Use a suitable lifting device (chain hoist or hydraulic floor jack) with 1000 lb. (454 kg) minimum lifting capacity. Do not use lifting device to hold vehicle in raised position. Use approved jack stands of proper weight capacity to support the vehicle and chock the wheels that remain on the floor. When not performing a test or service procedure that requires movement of the wheels, lock the brakes.

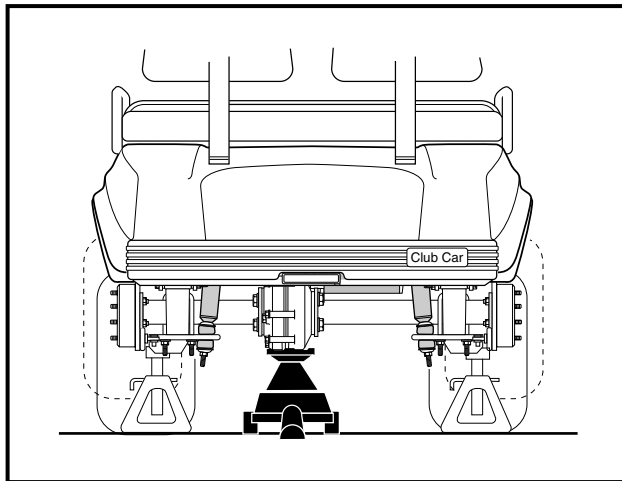

Figure 15-2 Vehicle Raised with Floor Jack

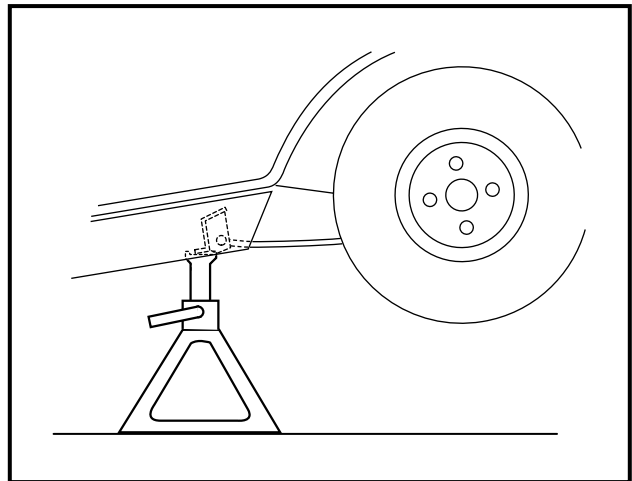
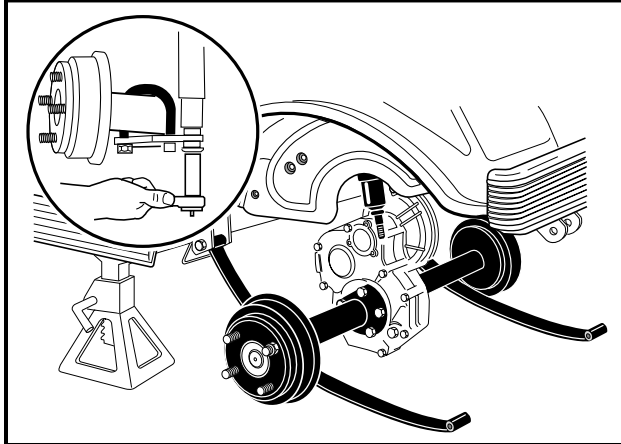

Figure 15-3 Vehicle on Jack Stands

5. Remove both rear wheels.
6. Remove the nut, cup washer, and bushing from the bottom side of the shock absorber. Compress the shock absorber (pushing upwards) to move it out of the way (**Figure 15-4, Page 15-4**).
7. Remove the nuts and bolts mounting the rear leaf springs to the shackles.

**Motor Removal, Continued:**

- To gain easier access to the motor, lower the transaxle as low as it will go. If more room is needed, remove the jack from beneath the transaxle and allow the springs to rest on the floor (**Figure 15-4, Page 15-4**).



**Figure 15-4 Transaxle Removal**

- Remove the four bolts that mount the motor to the transaxle (**Figure 15-19, Page 15-13**). See following **CAUTION**.

**⚠ CAUTION**

- Do not position fingers under motor when sliding motor off of the input shaft. Fingers may get pinched when motor disengages.

- Carefully slide the motor away from the transaxle until the motor spline disengages the input shaft and remove the motor from the vehicle.

**Motor Disassembly**

- Before beginning disassembly, place match marks on the motor end shield and stator shell, then place the motor in a vice with wooden blocks as shown (**Figure 15-5, Page 15-5**).
- Remove the four bolts (8) securing the end shield (10) to the stator shell (2).
- Remove the two screws (9) attaching the end shield to the bearing retainer.
- Slide the armature (17) out of the opposite end of the stator shell (2).
- Remove the two screws (11) attaching the brush rigging (12) to the stator shell (**Figure 15-10, Page 15-8**).
- Mark the brush terminal posts (A1 and A2) (27, 28) to identify their positions in the stator shell. Remove the nuts (6) and flat washers (5) (**Figure 15-10, Page 15-8**). From the outside, push the posts through the stator shell wall and into the interior of the stator shell.
- Carefully remove the brush rigging and the terminal posts from the stator shell.
- To remove brush springs (14) from rigging, lift the spring extensions out and over the brush mounts and then slide the springs off their mounting tabs (**Figure 15-6, Page 15-5**).

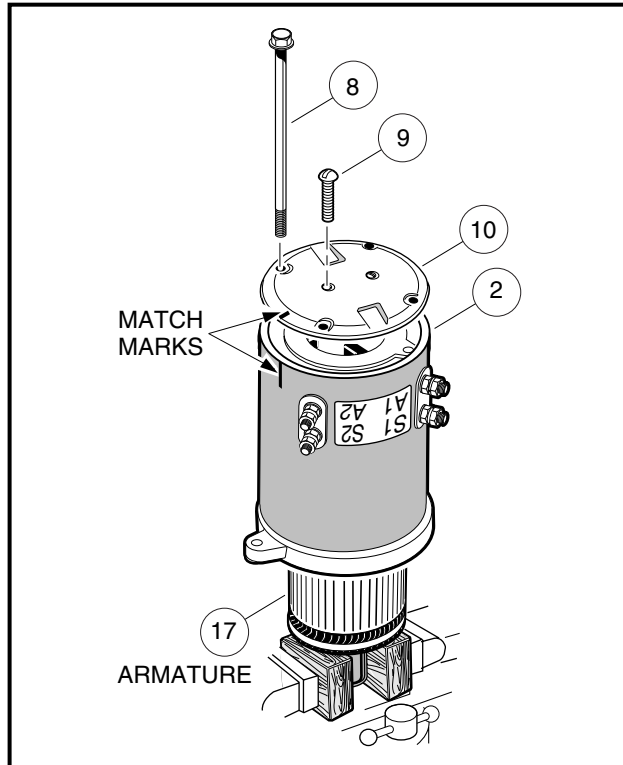

Figure 15-5 Motor Disassembly

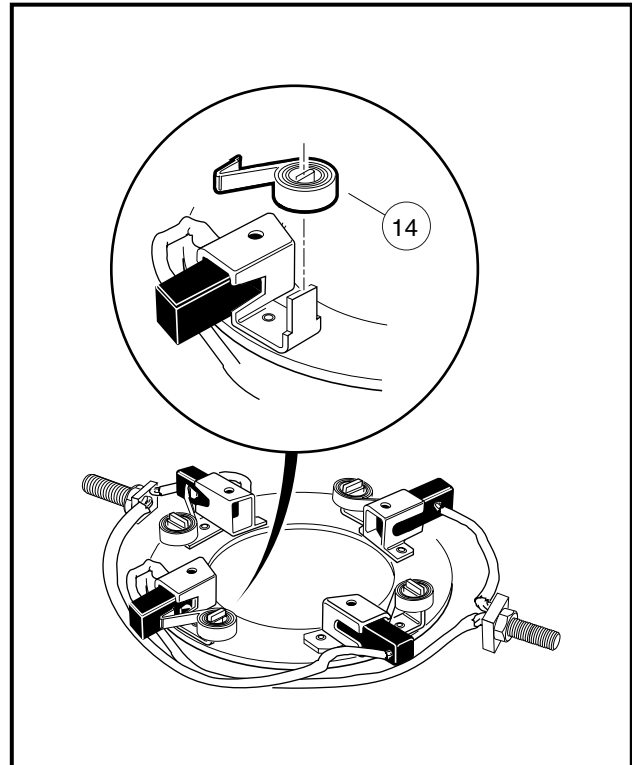

Figure 15-6 Brush Spring Removal

## MOTOR COMPONENT TESTING AND INSPECTION

See General Warning, Section 10, Page 10-1.

### ARMATURE

#### Visual Inspection

Disassemble the motor and carefully inspect the armature for the following characteristics:

- Burned, charred or cracked insulation
- Improperly cured varnish
- Thrown solder
- Flared armature windings
- Damaged armature core laminations
- Worn, burned or glazed commutators
- Dirty or oily commutators
- Raised commutator bars
- Worn armature bearing or shaft

**Visual Inspection, Continued:**

A dirty or oily commutator should be cleaned and wiped dry. Abnormalities identified during the inspection can help determine original cause of failure. Slight roughness of the commutator can be polished smooth with 400 grit or finer sandpaper. **See following CAUTION and NOTE.**

**CAUTION**

- Do not use emery cloth to polish the commutator. Particles of emery are conductive and may short-circuit the commutator bars. Do not use oil or lubricants on the commutator or brushes.

**NOTE:** Oil on the commutator may indicate a faulty transaxle input shaft oil seal.

**Armature Ground Test****CAUTION**

- Do not submerge the armature in solvent.

**NOTE:** Before testing the armature, wipe it clean with a clean cloth. Remove any carbon dust and metal particles from between the commutator bars.

1. With a multimeter set to 200  $\Omega$  (ohms), place one probe on the commutator and the other on the armature core. The multimeter should indicate no continuity (**Figure 15-7, Page 15-6**). If the reading is incorrect, replace the armature.

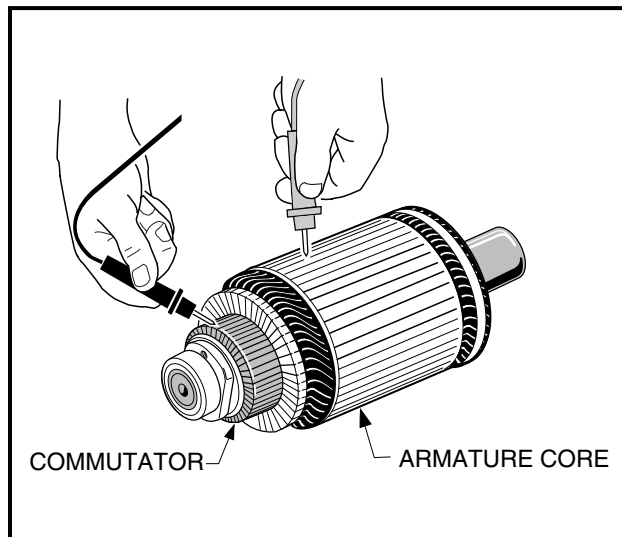

Figure 15-7 Armature

**FIELD WINDINGS INSPECTION**

Burned or scorched insulation on the field windings indicates the motor has overheated due to overloads or grounded or shorted coil windings. If the insulation on the field windings is scorched, replace the motor or the stator shell assembly.

## MOTOR COMPONENTS

1. Inspect the insulators (4 and 7) for cracks or other damage (**Figure 15-10, Page 15-8**).
2. Inspect the brushes (13) for damage or excessive wear. Replace brushes if required. **See following NOTE.**
3. Inspect the brush springs (14) (**Figure 15-10, Page 15-8**). Replace springs that are discolored from heat (light gold or blue tinted). Replace springs which apply a force of less than 16 oz. (**Figure 15-8, Page 15-7**). **See following CAUTION and NOTE.**

### CAUTION

- **When checking brush spring tension, do not over-extend the spring. Using excessive force will damage the spring.**

**NOTE:** When installing new brushes, remove and replace brushes one at a time. This method ensures the terminals and brushes will be properly positioned in the rigging. Refer to Motor Assembly for brush installation. **See Motor Assembly on page 15-10.**

*When replacing brushes, replace all four brushes. Never replace only two.*

*Install the brushes in the same rigging 180° apart from each other.*

## BEARING INSPECTION

1. Using a clean cloth, wipe the carbon dust off the bearing. Inspect the bearing by spinning it by hand and checking for both axial (A) and radial (B) play (**Figure 15-9, Page 15-7**).
2. Replace the bearing if it is noisy, does not spin smoothly, or has excessive play. Check the bearing and replace if rusted, worn, cracked, or if there is an abnormal color change in the metal of the bearing. Do not remove the bearing from the armature shaft unless it is to be replaced.

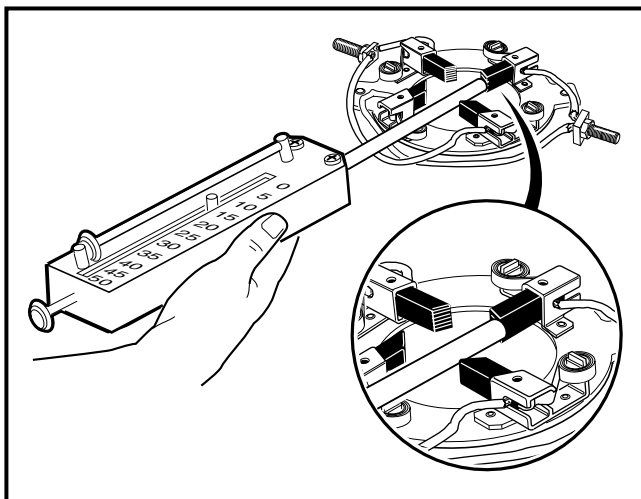

**Figure 15-8** Brush Spring Tension Test

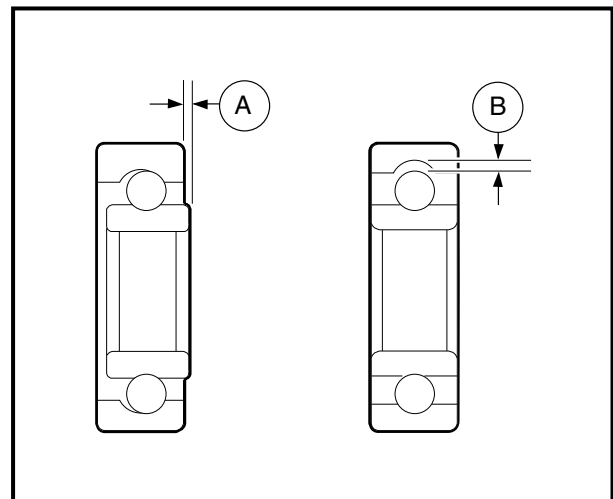

**Figure 15-9** Bearing Inspection

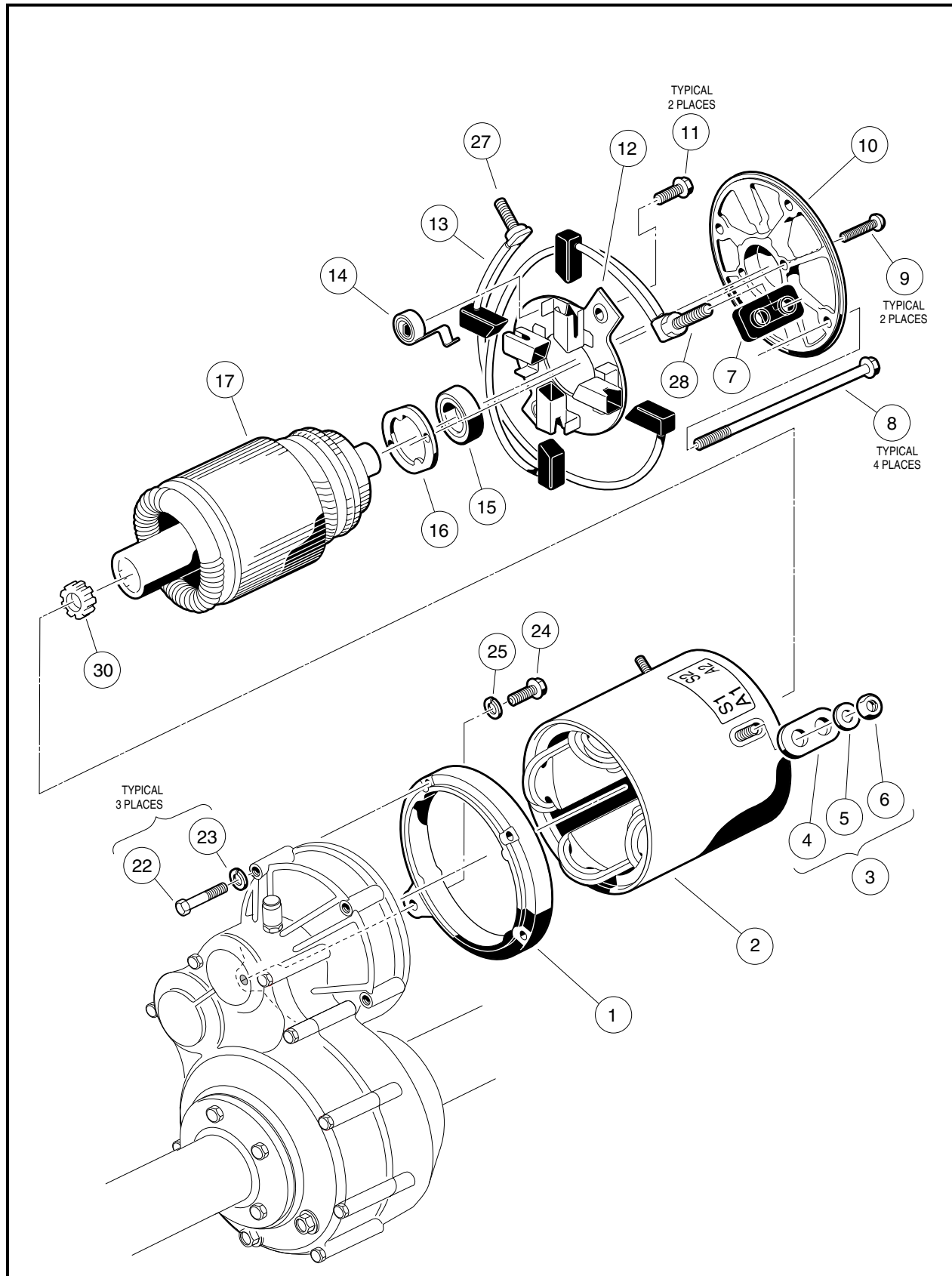

Figure 15-10 Motor



## BEARING REMOVAL

1. Place the wedge attachment tool (CCI P/N 1012812) between the bearing (15) and the armature (17) (**Figure 15-10, Page 15-8**). Make sure the wedge attachment tool is supporting the inner race of the bearing. If a press is not available, secure a bearing puller (CCI P/N 1012811) to the bearing and pull the bearing off the end of the armature shaft. Support the shaft so it will not drop when the bearing is removed (**Figure 15-11, Page 15-9**). Discard the bearing.

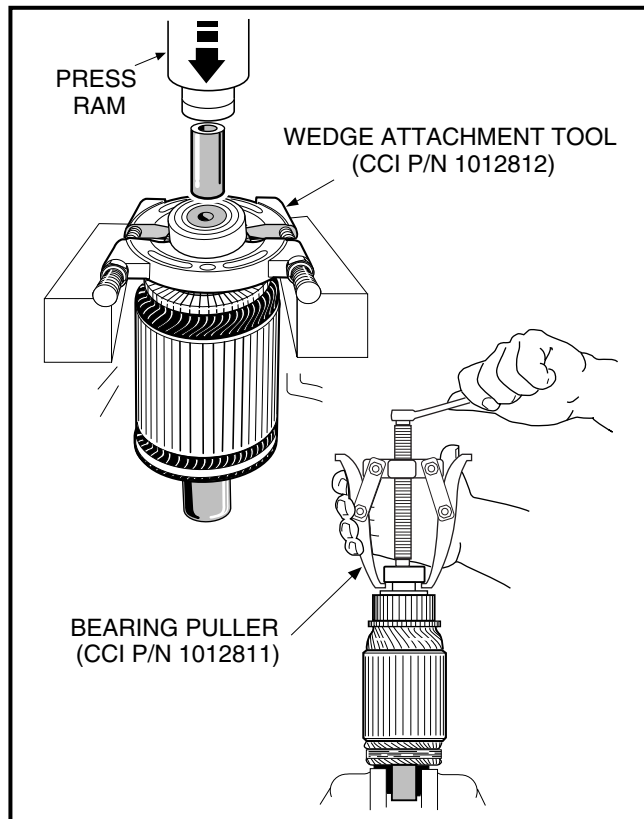

Figure 15-11 Bearing Removal

## BEARING INSTALLATION

1. Press a new bearing (15) onto the armature (**Figure 15-10, Page 15-8**). Use an arbor press that exerts pressure on the inner race only. **See following NOTE.**

**NOTE:** Make sure the bearing retainer (16) is positioned on the armature shaft before the bearing is pressed onto the armature (**Figure 15-10, Page 15-8**).

*An arbor with an outside diameter of less than 5/8 inch (16 mm) should be used to press the bearing onto the armature.*

## RECONDITIONING THE MOTOR

**See General Warning, Section 10, Page 10-1.**

Motor reconditioning must be performed by a qualified motor repair technician. The use of proper tools and procedures is absolutely essential for successful motor reconditioning.

## Motor Specifications

Any rework must be performed by a qualified technician. Motor service specifications are listed in the following table.

ITEM	SERVICE LIMIT
Commutator diameter (minimum)	2.265 in. (66.675 mm)
Commutator concentric with armature shaft within	0.001 in. (0.0254 mm)
Limit depth of cut when machining commutator	0.005 in. (0.127 mm)
Bar to bar run out should not exceed	0.0002 in. (0.00508 mm)
If undercut of segment insulator is less than 0.016 inch (0.406 mm), then it should be undercut to	0.031 in. (0.8 mm)
Machined face of commutator	8-16 microinches (203.2-406.4 nm)
Field coil resistance (V-Glide 36 volt, 2.97 hp)	0.00711 $\Omega$ (ohms)

## MOTOR ASSEMBLY

### See General Warning, Section 10, Page 10-1.

1. If the bearing has been removed, replace the bearing. **See Bearing Installation on page 15-9.**
2. Install the brushes. **See following NOTE.**

**NOTE:** When installing new brushes, remove and replace brushes one at a time. This method ensures the terminals and brushes will be properly positioned in the rigging.

*When replacing brushes, replace all four brushes. Never replace only two.*

*Install the brushes in the same rigging 180° apart from each other.*

- 2.1. With brush rigging facing down and held slightly above the stator shell, insert the two terminal posts through the insulators in the stator shell wall at the A1 and A2 positions. Insert the brush holder screws through the holes in the brush rigging and into the threaded holes in the mounting bracket (**Figure 15-12, Page 15-11**). Tighten the screws to 20 in-lb (2.2 N·m).
- 2.2. One at a time, push brush spring extensions back from brushes and slide the brushes back until they are completely retracted into their mounting slots. Then position the brush springs against the sides of the brushes so that spring pressure will hold them in the retracted position (**Figure 15-6, Page 15-5**).
- 2.3. Slide the armature, bearing end first, into the stator shell. Make sure the brushes are held back while positioning the armature for proper commutator/brush contact. Release the brushes and place the springs outside the brushes so the brushes are being held against the commutator. **See following CAUTION.**

## CAUTION

- If the motor is being assembled with the armature standing on end as the commutator is positioned, make sure the brushes are held back. Do not allow the brushes to support the weight of the stator shell. The brushes can be easily damaged by this weight.

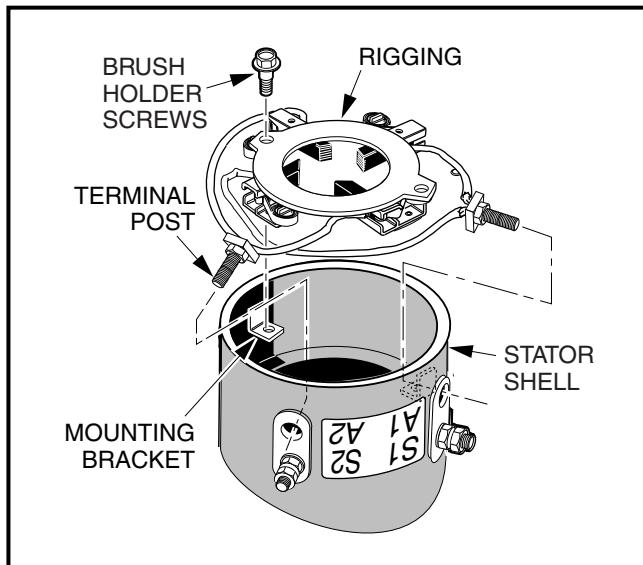

Figure 15-12 Brush Installation

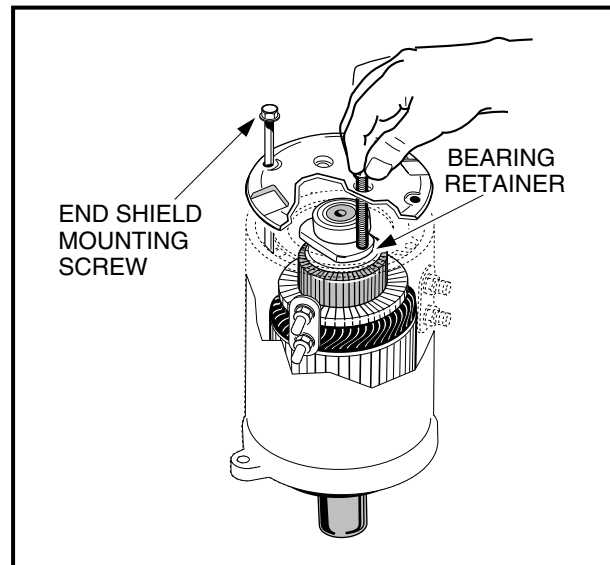

Figure 15-13 End Shield Installation

3. Install end shield onto the stator shell.

- 3.1. Attach the end shield (10) to bearing retainer (16) by aligning the two holes in the bearing retainer with the two mating holes in end shield and installing the screws (9) (**Figure 15-10, Page 15-8**). Tighten the screws to 17 in-lb (1.9 N·m). **See following NOTE.**

**NOTE:** Use a long screw with the same thread specifications as the mounting screws to maintain hole alignment while starting the first mounting screw (**Figure 15-13, Page 15-11**).

- 3.2. Align the match marks on the end shield and the stator shell, then install the four screws (8) (**Figure 15-10, Page 15-8**). Tighten the screws to 90 in-lb (10 N·m).

4. Make sure the armature turns freely. If it does not turn freely, disassemble the motor to find the problem. Make sure the bearing is properly seated in the end shield when assembling the motor.

## MOTOR INSTALLATION

See General Warning, Section 10, Page 10-1.

1. Clean the transaxle input shaft.
  - 1.1. Spray the input shaft thoroughly with CRC® Brakleen™ or equivalent brake cleaner degreaser.
  - 1.2. Wipe input shaft with a clean cloth.
  - 1.3. Inspect the grooves of the input shaft and remove any remaining debris.
  - 1.4. Repeat steps 1.1 through 1.3 until input shaft is clean.

**Motor Installation, Continued:**

2. Lubricate the transaxle input shaft.
  - 2.1. Squeeze approximately 1/2 inch (1.3 cm) of moly-teslon lubricant (CCI P/N 102243403) from tube onto a putty knife as shown (**Figure 15-14, Page 15-12**).
  - 2.2. Rotate wheels to rotate input shaft.
  - 2.3. Apply motor coupling grease evenly to the rotating input shaft starting at approximately 1/8 inch (3.1 mm) from the end of the shaft and working back toward the transaxle (away from the end of the shaft) (**Figure 15-15, Page 15-12**).

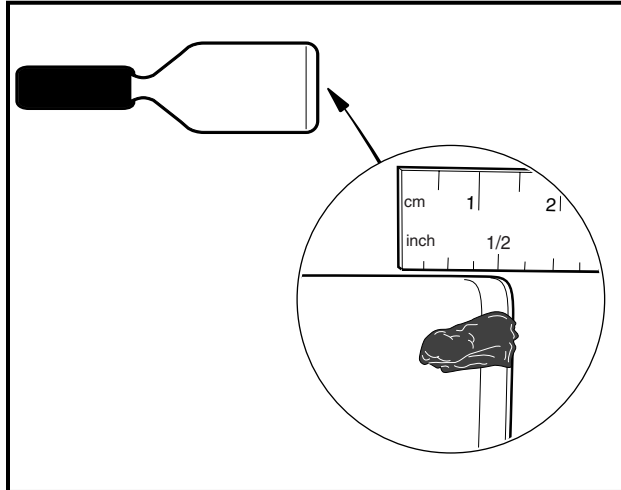

**Figure 15-14 Grease on Putty Knife**

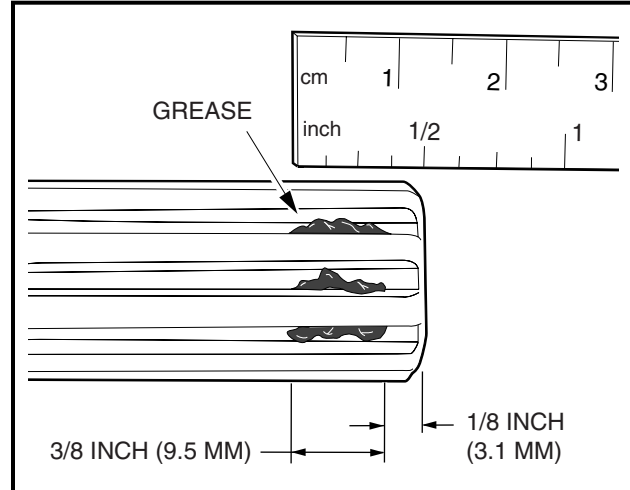

**Figure 15-15 Application of Grease to Input Shaft Grooves**

- 2.4. The grease should be evenly distributed in the grooves to a width of approximately 3/8 inch (9.5 mm).
- 2.5. Using a flat screwdriver, clean the grease out of one of the grooves to allow air to escape when the motor is pushed onto the input shaft.
- 2.6. Check the chamfer and end of the input shaft to ensure these areas are completely clean of grease as shown (**Figure 15-16, Page 15-13**).
3. Install the molded bumper.
  - 3.1. With the flat side toward the bottom of the coupling, install the molded bumper (30) into the motor coupling (**Figure 15-10, Page 15-8**). **See following NOTE.**

**NOTE:** The motor coupling and the new molded bumper must be new and free of grease and debris.

- 3.2. Ensure that the installed bumper is seated at the bottom of the coupling.
4. Install the motor on the transaxle.
  - 4.1. Slide the motor coupling onto the transaxle input shaft. **See following NOTE.**

**NOTE:** The coupling will push any excess grease on the input shaft along the shaft toward the transaxle.

When the motor is pushed onto the input shaft, the motor adapter ring (1) will not bottom out against the transaxle housing (**Figure 15-10, Page 15-8**). There will be approximately 1/16 inch (1.6 mm) gap between the motor adapter ring and transaxle housing as shown (**Figure 15-17, Page 15-13**).

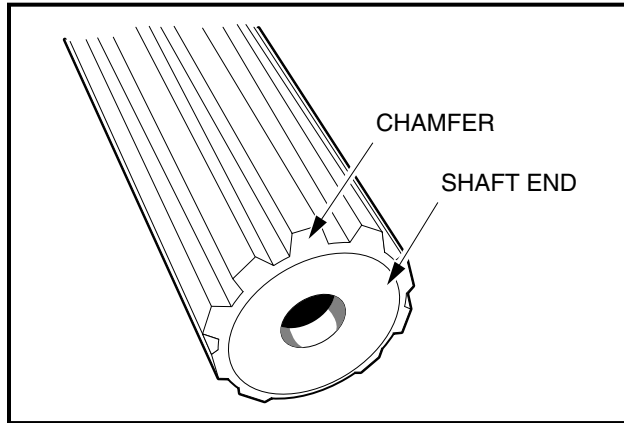

Figure 15-16 Clean Chamfer and Input Shaft End

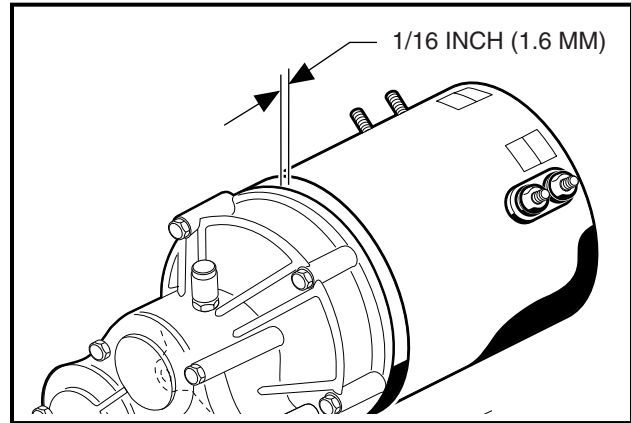

Figure 15-17 Gap at Motor and Transaxle

- 4.2. Loosely install four motor bolts and washers that secure the motor to the transaxle. Do not tighten.
- 4.3. Begin finger-tightening the bolts (1 and 2) in the sequence indicated (**Figure 15-19, Page 15-13**). Continue tightening by hand until the motor is seated in the transaxle housing. **See following CAUTION and NOTE.**

### **CAUTION**

- **Make sure the motor is properly seated in the transaxle housing.**

**NOTE:** Failure to install and tighten the motor mounting bolts in the proper sequence and to the proper tightness may result in motor noise during operation.

- 4.4. Tighten the bolt (24) inserted through the tab to 155 in-lb (17.5 N·m) (**Figure 15-18, Page 15-13**).

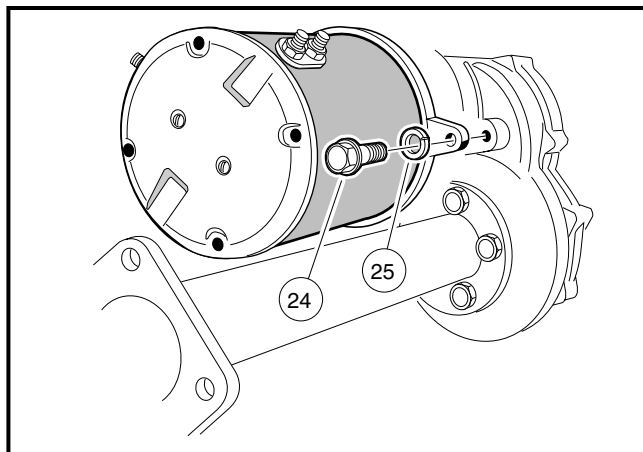

Figure 15-18 Motor Installation

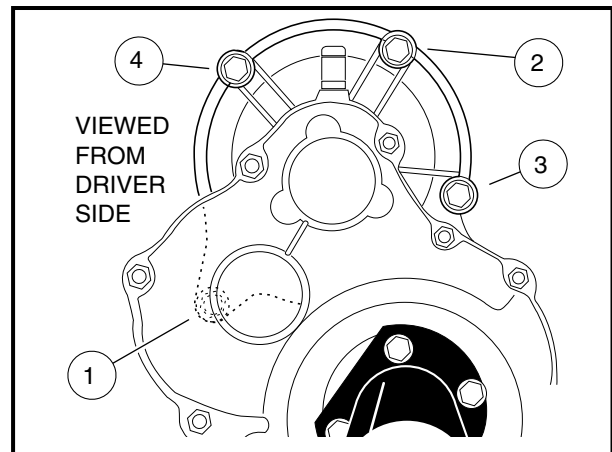

Figure 15-19 Motor Mount

- 4.5. Tighten the center bolt (2) to 65 in-lb (7.3 N·m) (**Figure 15-19, Page 15-13**).
- 4.6. Tighten the right bolt (3) to 65 in-lb (7.3 N·m).
- 4.7. Tighten the left bolt (4) to 65 in-lb (7.3 N·m).
- 4.8. Install the motor wires, making sure they are connected to the correct motor terminals and that the terminal orientation is correct. **See Wiring Diagram, Section 11, Page 11-4.** Tighten the terminal retaining nuts to 65 in-lb (7.3 N·m).

**Motor Installation, Continued:**

5. If using a chain hoist, lower the vehicle and guide the leaf springs into the shackles. If using a floor jack, raise the transaxle until the leaf springs can be guided into the shackles.
6. Insert the mounting bolts through the spring shackles and the bushings in the leaf spring eyes and install lock nuts. Tighten the bolts to 23 ft-lb. (31 N·m). **See Section 9 – Rear Suspension in the DS Golf Car Maintenance and Service Manual.**
7. Install the shock absorbers. Tighten nut until rubber bushing expands to the diameter of the cup washer.
8. Install the wheels and finger-tighten the lug nuts.
9. Lift vehicle and remove jack stands. Lower vehicle to the floor and tighten lug nuts, using a crisscross pattern, to 55 ft-lb (74.6 N·m).
10. Connect the battery cables, positive (+) cable first, and tighten to 110 in-lb (12.4 N·m). Coat with Battery Terminal Protector Spray (CCI P/N 1014305) to minimize corrosion.
11. Inspect the vehicle for proper operation.
  - 11.1. Make sure that the vehicle operates in the forward direction when the Forward/Reverse switch is in the FORWARD position.
  - 11.2. Make sure that the vehicle operates in the reverse direction when the Forward/Reverse switch is in the REVERSE position. The reverse buzzer will sound as a warning when the Forward/Reverse switch is in REVERSE.
  - 11.3. Make sure that the vehicle does not operate when the Forward/Reverse switch is in the NEUTRAL position.

## SECTION 16A – TRANSAXLE (TYPE G)

---

### **⚠ DANGER**

- See General Warning, Section 10, Page 10-1.

### **⚠ WARNING**

- See General Warning, Section 10, Page 10-1.

## TRANSAXLE IDENTIFICATION

---

Club Car electric vehicles utilize one of two types of transaxles. The different transaxles are identified by the orientation of the gear case bolt heads:

- The Type G transaxle has gear case bolt heads oriented toward the passenger side of the vehicle.
- The Type K transaxle has gear case bolt heads oriented toward the driver side of the vehicle.

Please note that parts used in these transaxles are not interchangeable with one another. Determine which transaxle vehicle is equipped with before proceeding with service.

*This section pertains to Type G transaxles only. For information and procedures on Type K transaxles, proceed to Section 16b – Transaxle (Type K).*

## LUBRICATION

---

**See General Warning, Section 10, Page 10-1.**

There are two plugs located on the lower half of the transaxle housing. The upper plug (21) (as viewed when the vehicle is on a level surface) is used as a lubricant level indicator (**Figure 16a-5, Page 16a-3**). When the vehicle is parked on a level surface, the lubricant level should be even with the bottom of the hole. The lower plug (22) is for draining the lubricant. When draining the lubricant, the upper plug should be removed so the lubricant will drain faster. Be sure the drain plug is reinstalled before filling. **See following NOTE.**

**NOTE:** *Recycle or dispose of used oil or lubricant in accordance with local, state, and federal regulations.*

## AXLE BEARING AND SHAFT

---

**See General Warning, Section 10, Page 10-1.**

### AXLE SHAFT

#### Axle Shaft and Oil Seal Removal

1. Place chocks at the front wheels. Loosen lug nuts on rear wheels and lift the rear of the vehicle with a chain hoist or floor jack. Place jack stands under the axle tubes to support the vehicle.
2. Remove the rear wheel and brake drum. **See Section 6 – Wheel Brake Assemblies and Section 8 – Wheels and Tires in the appropriate maintenance and service manual.**

**Axle Shaft and Oil Seal Removal, Continued:**

3. Use 90° internal snap ring pliers to remove the internal retaining ring (6) from the axle tube (**Figure 16a-5, Page 16a-3**). See also **Figure 16a-1, Page 16a-2**.
4. Remove the axle, retaining ring, and bearing assembly by pulling the axle straight out of the housing.
5. If necessary, remove the axle oil seal and adapter ring.
  - 5.1. Use a bearing puller (CCI P/N 1016417) to remove the axle seal and adapter ring from the axle tube (**Figure 16a-2, Page 16a-2**). See following **CAUTION** and **NOTE**.

**CAUTION**

- Do not scar or damage the inside surfaces of the tube when removing the oil seal and adapter ring. A damaged tube might have to be replaced.

**NOTE:** Do not discard the adapter ring. If the adapter ring is lost or damaged, the axle tube will have to be replaced.

- 5.2. Use a press to separate the axle oil seal (15) from the adapter ring (39) (**Figure 16a-3, Page 16a-2**). Retain the adapter ring and discard the oil seal.
6. Inspect the axle shaft assembly to be sure the bearing and collar have not slipped and are still seated against the shoulder on the axle shaft.
7. Inspect bearing (5) (**Figure 16a-5, Page 16a-3**). If the bearing in a Type G transaxle is worn or damaged, the entire axle shaft assembly (1 or 2) must be replaced.

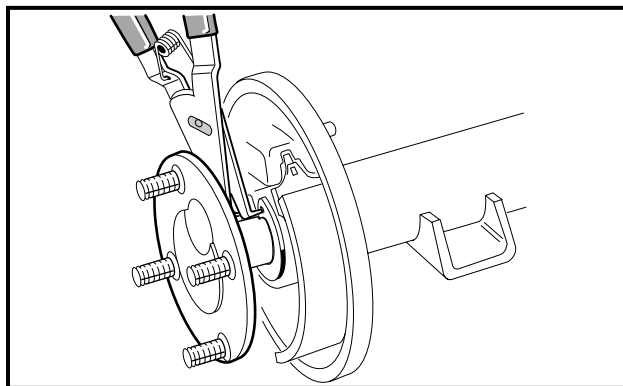

Figure 16a-1 Axle Tube

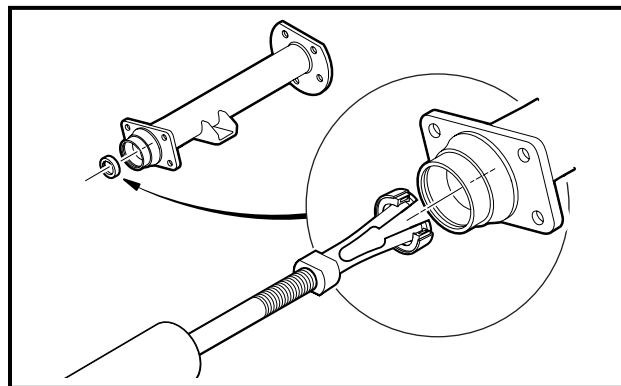

Figure 16a-2 Axle Seal and Adapter Ring Removal

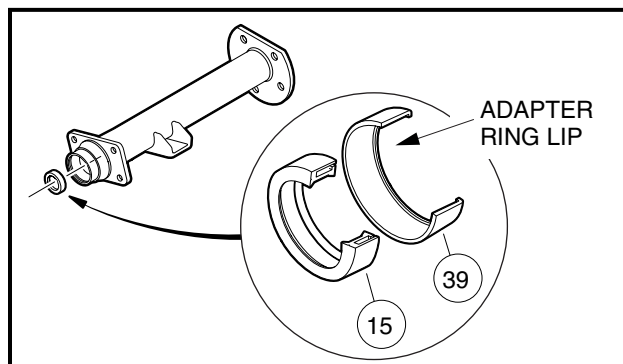

Figure 16a-3 Axle Seal and Adapter Ring

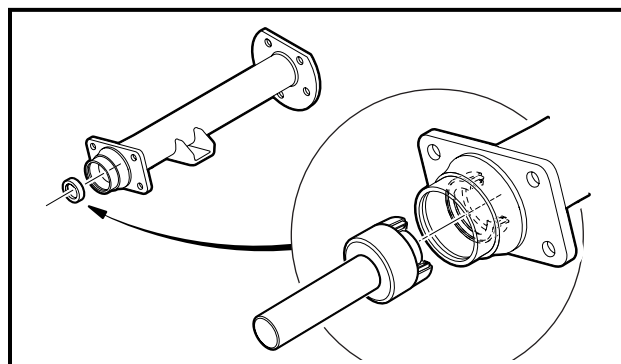

Figure 16a-4 Axle Seal and Adapter Ring Installation





## Axle Shaft and Oil Seal Installation

1. If previously removed, install a new oil seal.
  - 1.1. Clean seal seat in the adapter ring (39) (**Figure 16a-3, Page 16a-2**).
  - 1.2. Place a new seal (15) in the adapter ring with the seal lip facing toward the adapter ring lip (**Figure 16a-3, Page 16a-2**). Use an axle seal tool (CCI P/N 1014162) and mallet to tap it in until it seats firmly in position (**Figure 16a-3, Page 16a-2**). A hydraulic press may also be used with the axle seal tool.
  - 1.3. Clean adapter ring seat(s) in the axle tube (14 or 35) (**Figure 16a-5, Page 16a-3**).
  - 1.4. Apply Loctite® 603 to the outer diameter of the adapter ring.
  - 1.5. Place the oil seal and adapter ring assembly into the axle tube with the seal lip facing away from the bearing (**Figure 16a-4, Page 16a-2**). Use an axle seal tool (CCI P/N 1014162) and mallet to tap it in until it seats firmly in position. **See following CAUTION.**

### **⚠ CAUTION**

- **Clean any residual oil from the exposed end of the axle shaft and from the oil seal area prior to installing the axle shaft.**
2. Clean the shaft splines and then insert the shaft, splined end first, through the seal and into the axle tube. Be careful not to damage the seal. Then advance the shaft through the inner bearing and rotate it to align the shaft splines with the splined bore of the differential side gear (27) (**Figure 16a-5, Page 16a-3**). Continue advancing the shaft until the bearing seats against the axle tube shoulder.
  3. Use a pair of snap ring pliers to install the retaining ring (6) inside axle tube (**Figure 16a-5, Page 16a-3**). **See following NOTE.**

**NOTE:** *If the retaining ring (6), axle bearing (5), or sleeve (4) must be replaced, the entire axle shaft assembly (1 or 2) must be replaced (**Figure 16a-5, Page 16a-3**).*

4. Place a 1/4 to 3/8-inch (6 to 10 mm) diameter rod against the retaining ring and tap lightly at four to five locations around the retaining ring to ensure it is properly seated. **See following WARNING.**

### **⚠ WARNING**

- **Be sure the retaining ring is properly seated in its groove. If the ring is not properly installed, the axle assembly will separate from the transaxle and damage the axle assembly and other components. Loss of vehicle control could result, causing severe personal injury.**
5. If a new oil seal was installed, allow 24 hours before operating the vehicle to allow the Loctite® 603 to fully cure.

## AXLE BEARING

Do not remove the axle bearing (5) from a Type G transaxle. If bearing is worn or damaged, the entire axle assembly (1 or 2) must be replaced (**Figure 16a-5, Page 16a-3**).

## TRANSAXLE

**See General Warning, Section 10, Page 10-1.**

## TRANSAXLE REMOVAL

1. Place chocks at the front wheels and slightly loosen lug nuts on both rear wheels.
2. Place a floor jack under the transaxle and raise the rear of the vehicle. Position jack stands under the frame crossmember between the spring mount and the side stringer, just forward of each rear wheel. Lower the vehicle to let the jack stands support the vehicle (**Figure 16a-6, Page 16a-5**).
3. Remove the rear wheels, then thread one lug nut onto a stud on each rear hub. This will keep the brake drums on the hubs.
4. Remove the bow-tie pins (1), brake cable clevis pins (2), and cable retaining E-clips (3). Disconnect the brake cables (4) (**Figure 16a-7, Page 16a-5**).

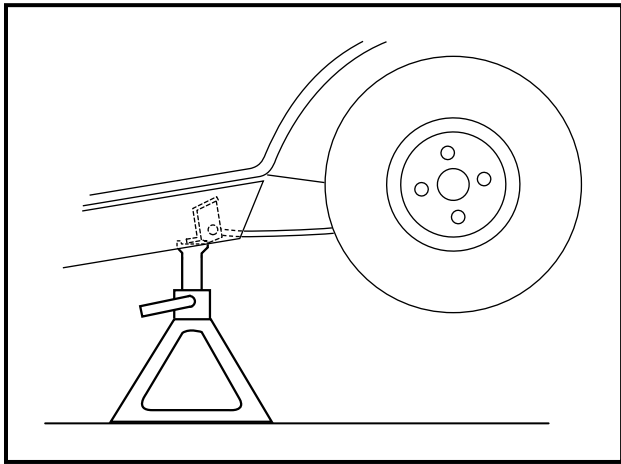

Figure 16a-6 Vehicle Supported on Jack Stands

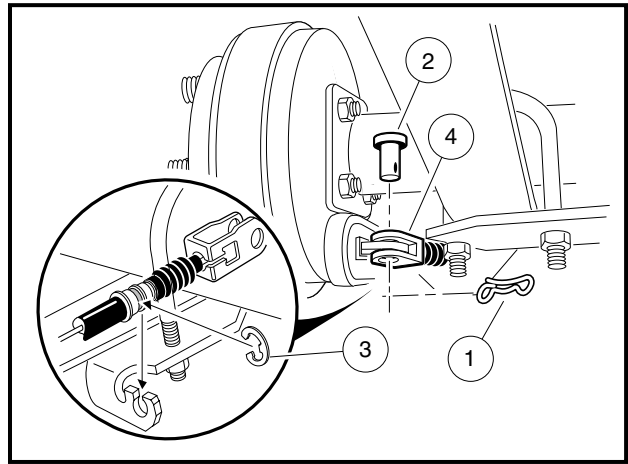

Figure 16a-7 Disconnect Brakes

5. Disconnect the shock absorbers from their lower mounts (**Figure 16a-8, Page 16a-5**).
6. Disconnect the four motor wires. Use two wrenches to prevent the post from turning.
7. With a floor jack supporting the transaxle, remove lower spring shackle nuts and bolts. Position shackles so they are clear of springs (**Figure 16a-9, Page 16a-5**).

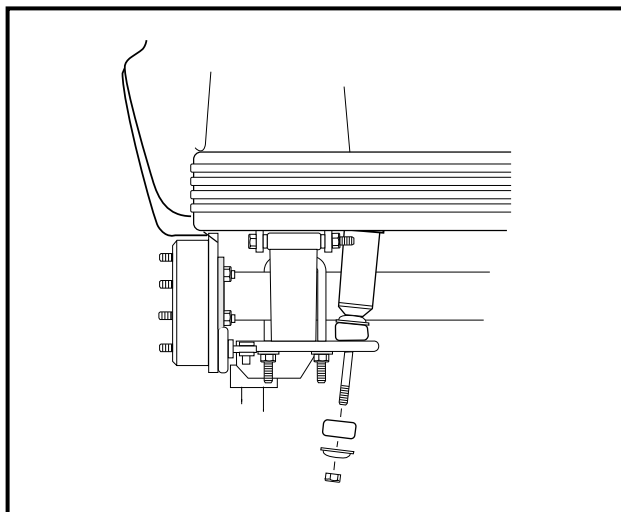

Figure 16a-8 Disconnect Shocks

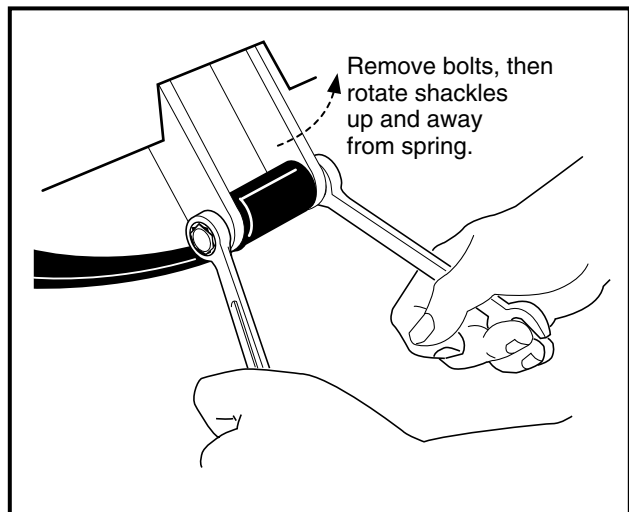

Figure 16a-9 Shackles

**Transaxle Removal, Continued:**

8. If a chain hoist was used to raise the vehicle, lift the vehicle high enough to permit easy access and clearance for removal of the motor. If a floor jack was used to raise the vehicle, lower the transaxle enough to permit easy access and clearance for removal of the motor.
9. Remove the three motor mounting bolts (**Figure 16a-11, Page 16a-6**) and the motor positioning bolt (**Figure 16a-12, Page 16a-7**) mounting the motor to the transaxle. **See following CAUTION.**

**⚠ CAUTION**

- Do not position fingers under motor when sliding motor off of the input shaft. Fingers may get pinched when motor disengages.

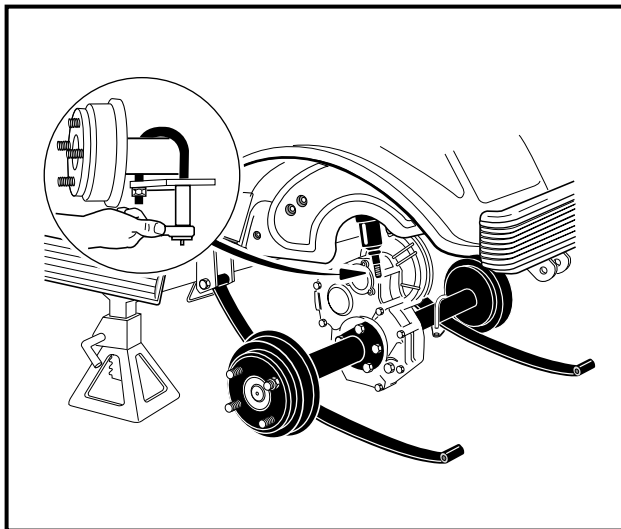
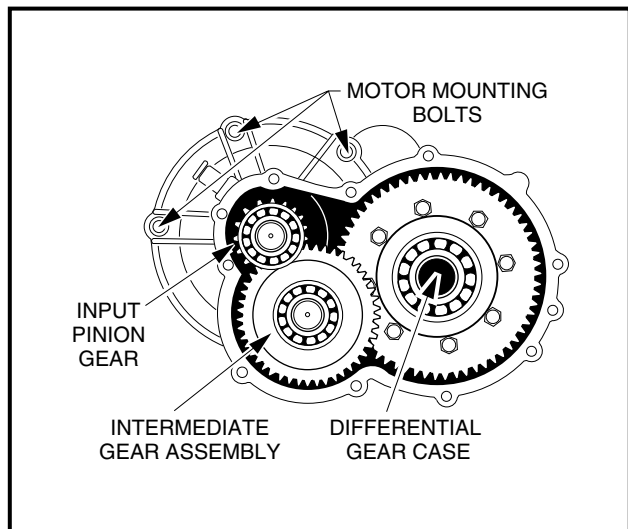
**Figure 16a-10 Leaf Springs****Figure 16a-11 Motor Mounting Bolts**

10. Carefully remove the motor from the transaxle. Slide the motor away from the transaxle until the motor spline becomes disengaged from the input shaft, then lift motor out. **See preceding CAUTION.**
11. If a floor jack was used, pull floor jack from beneath the transaxle and allow the springs to rest on the floor.
12. Remove the U-bolts attaching the transaxle to the leaf springs (**Figure 16a-10, Page 16a-6**).
13. Carefully lift each end of the transaxle off its positioning pin (on the leaf spring) and slide the transaxle to the rear and out of the vehicle.
14. Drain the lubricant from the transaxle and remove the axle shafts. **See Axle Shaft and Oil Seal Removal on page 16a-1. See following NOTE.**

**NOTE:** Recycle or dispose of used oil or lubricant in accordance with local, state, and federal regulations.

15. Remove the brake assemblies if required. **See Section 6 – Wheel Brake Assemblies in the appropriate maintenance and service manual.**

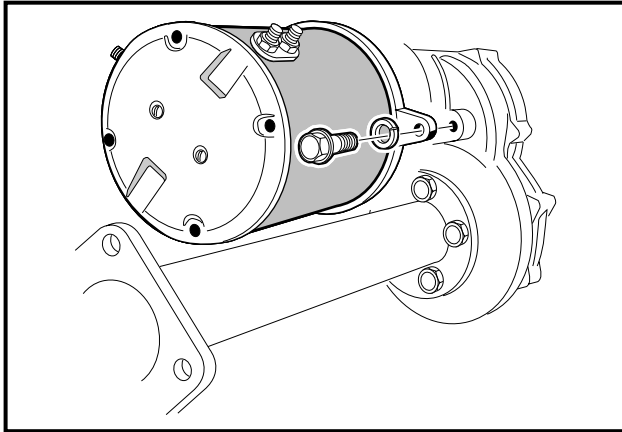

Figure 16a-12 Motor Positioning Bolt

## TRANSAXLE DISASSEMBLY, INSPECTION, AND ASSEMBLY

See General Warning, Section 10, Page 10-1.

### TRANSAXLE DISASSEMBLY AND INSPECTION

1. To detach axle tubes (14 and 35) from the transaxle housing, remove the bolts and lock washers (8 and 9) (Figure 16a-5, Page 16a-3).
2. Remove 11 bolts (24) that hold housing together.
3. Pull the halves of the housing (11 and 20) apart. If necessary, tap lightly on the spline of the input pinion (17). See following CAUTION.

#### **CAUTION**

- To prevent damage to the housing mating seal surfaces, use caution when separating halves.

4. Remove input pinion gear (17) by pulling gear out while rocking intermediate gear assembly (19). Lift intermediate gear assembly and differential gear case unit out simultaneously (Figure 16a-5, Page 16a-3). See following CAUTION.

#### **CAUTION**

- Do not damage gears. Use extreme care when handling them.

5. Use a bearing puller or arbor press to remove bearings (16) from the input pinion gear. If the oil seal (10) is damaged, replace it (Figure 16a-5, Page 16a-3). See also Figure 16a-13, Page 16a-8. See following CAUTION.

#### **CAUTION**

- Do not reuse bearings after removing them. Replace bearings with new ones.

6. To disassemble the intermediate gear assembly, press off together the bearing (16) and the gear (19) (Figure 16a-5, Page 16a-3). See also Figure 16a-13, Page 16a-8.

**Transaxle Disassembly and Inspection, Continued:**

7. Press the bearing (18) off the intermediate gear assembly (**Figure 16a-5, Page 16a-3**).

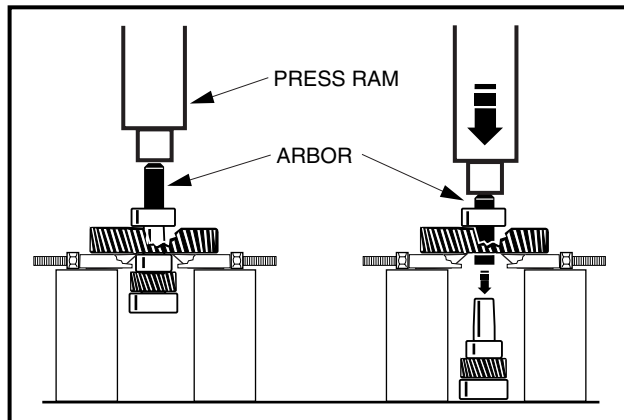

**Figure 16a-13 Intermediate Gear Assembly**

8. Disassemble the differential gear case:

- 8.1. Remove four hex bolts (33) that secure the ring gear to the differential case (**Figure 16a-5, Page 16a-3**).
- 8.2. Remove the ring gear. Retain dowel pin (34) from between the ring gear and differential case for reassembly.
- 8.3. Separate the differential gear case housing. If necessary, reinstall two of the hex bolts (removed previously in step 8.1) into the differential gear unit and, while holding the unit slightly above the work area, lightly tap the bolt heads (**Figure 16a-14, Page 16a-8**). Remove the two bolts.

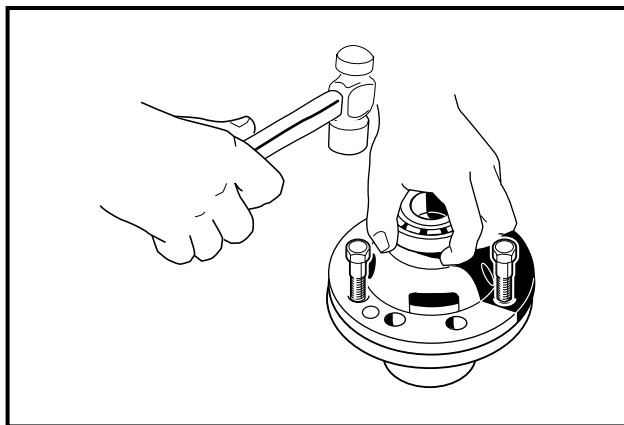

**Figure 16a-14 Separate Housing**

- 8.4. Remove the differential pin (31) by pushing pin through differential gear case from one side (**Figure 16a-5, Page 16a-3**). See also **Figure 16a-15, Page 16a-9**.
- 8.5. Remove the idler gears and thrust plates (1 and 2) (**Figure 16a-16, Page 16a-9**).

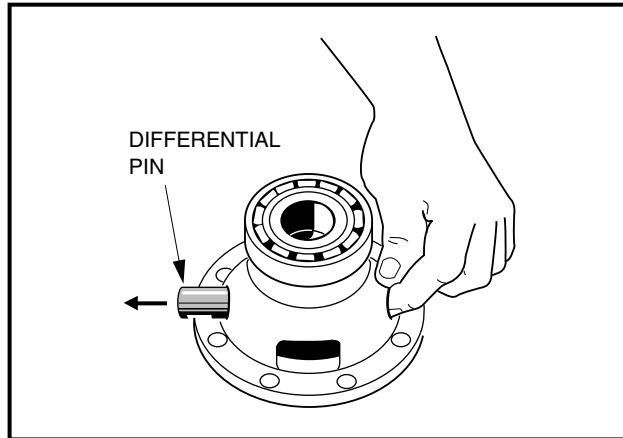

Figure 16a-15 Differential Pin

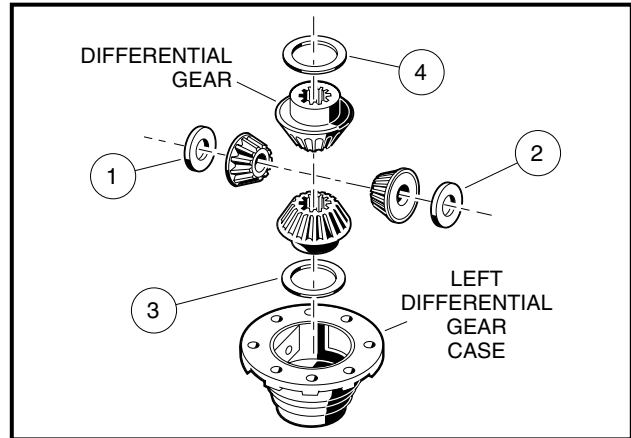

Figure 16a-16 Left Differential

8.6. Remove the differential gears and thrust plates (3 and 4).

8.7. Inspect the bearings (13) of the differential case (26) and replace them if they are damaged (Figure 16a-5, Page 16a-3). To remove them, press them off. **See following CAUTION.**

### **CAUTION**

- Do not reuse bearings after removing them. Replace bearings with new ones.

9. Inspect parts for wear or damage. Any worn or damaged parts should be replaced. **See following NOTE.**

**NOTE:** Damaged or worn gears should be replaced as sets.

## TRANSAXLE ASSEMBLY

### **CAUTION**

- Do not press against the bearing outer race.
- The housing and all parts must be wiped clean and dry before reassembly.

1. If bearings (13) were removed during disassembly, install new bearings using an arbor press (Figure 16a-5, Page 16a-3).
2. Assemble the differential gear case.
  - 2.1. Install the pin (31) (Figure 16a-5, Page 16a-3). Apply a small amount of oil to all thrust plates and to both ends of the pin.
  - 2.2. Install four hex bolts (33) and output gear (32). Tighten bolts to 51 ft-lb (69 N·m).
3. Press a new bearing (18) onto the intermediate gear assembly (Figure 16a-5, Page 16a-3).
4. Press new bearing (16) onto input pinion gear (17).
5. Apply grease to the lip of the new oil seal (10) and install the seal using a transaxle pinion seal tool (CCI P/N 1014161). The lip of the oil seal should face the inside of the transaxle housing. Make sure the seal is firmly seated.
6. Install the differential assembly, the intermediate gear assembly, and the input pinion gear simultaneously. Be sure all bearings are seated properly in the housing. Rotate the input shaft to check for smooth gear operation (Figure 16a-11, Page 16a-6).

**Transaxle Assembly, Continued:**

7. Install both dowel pins (25) in the transaxle housing (20) **(Figure 16a-5, Page 16a-3)**.
8. Install left half of transaxle housing:
  - 8.1. Place a 1/8-inch (3 mm) bead of Three Bond liquid gasket on mating surface of housing.
  - 8.2. Install left half of transaxle housing (20) **(Figure 16a-5, Page 16a-3)**.
  - 8.3. Install eleven bolts (24) in the case housing and tighten to 19 ft-lb (25.7 N·m). Type G transaxles have no shims or gasket.
  - 8.4. Install axle tube (14 and 35) with lock washers and bolts (9 and 8) **(Figure 16a-5, Page 16a-3)**. Tighten the bolts to 36 ft-lb (49 N·m).
9. Install the brake assemblies as instructed. **See Section 6 – Wheel Brake Assemblies in the appropriate maintenance and service manual.**
10. Apply a small amount of grease to the lip of the oil seal (15) **(Figure 16a-5, Page 16a-3)**. **See following CAUTION.**

** CAUTION**

- **Clean any residual oil from the exposed end of the axle shaft and from the oil seal area prior to installing the axle shaft.**
11. Clean the splines on the axle shaft (1 and 2). Rotate the axle to align the shaft splines with the splined bore of the differential side gear. Push the shaft in until the bearing seats against the shoulder in the axle tube.
  12. Install the retaining ring (6) in the axle tube. **See following WARNING.**

** WARNING**

- **Be sure the retaining ring is properly seated in its groove. If the ring is not properly installed, the axle assembly will separate from the transaxle and damage the axle assembly and other components. Loss of vehicle control could result, causing severe personal injury.**
13. Make sure the drain plug (22) is installed in the transaxle and tightened to 23 ft-lb (31 N·m). Fill the transaxle, through the level indicator hole, with 22 ounces of SAE 30 API Class SE, SF, or SG oil (a higher grade may also be used). Install and tighten the level indicator plug (21) to 23 ft-lb (31 N·m).

## TRANSAXLE INSTALLATION

---

**See General Warning, Section 10, Page 10-1.**

1. If using a chain hoist, raise the vehicle and place transaxle in position on the jack stands. If using a floor jack, lower the jack stands to their lowest settings and place the transaxle in position on the jack stands.
2. Align the center hole in the saddle of the transaxle with the pilot bolt in the leaf spring assembly.
3. Install the two U-bolts, jounce bumper mount (if required), and spacers, lock washers, and nuts. Tighten the nuts to 25 ft-lb (34 N·m). Tighten the U-bolt nuts so an equal amount of thread is visible on each leg of the bolt.
4. Install the motor. **See Section 15 – Motor.**



5. If using a chain hoist, lower the vehicle while guiding the leaf springs into the rear spring shackles. If using a floor jack, raise the differential while guiding the leaf springs into the rear spring shackles. Then raise the jack stands to support the transaxle.
6. Connect the four motor wires. Tighten the retaining nuts to 65 in-lb (7.3 N·m). Use two wrenches to prevent the posts from turning. **See following NOTE.**

**NOTE:** *If the motor wires were not tagged when disconnected, refer to the wiring diagram for proper connection. See Wiring Diagram, Section 11, Page 11-4.*

7. Insert bolts through the spring shackles and bushings in the leaf spring eyes. Secure bolts with lock nuts. Tighten to 15 ft-lb (20.3 N·m).
8. Connect the brake cables.
9. Install the shock absorbers. Tighten shock absorber retaining nuts until the rubber bushings expand to the same size as the cup washers.
10. Install the rear wheels and finger-tighten the lug nuts.
11. Lift the vehicle and remove the jack stands.
12. Lower vehicle and tighten the lug nuts, using a crisscross pattern, to 55 ft-lb (74.6 N·m).
13. Test drive the vehicle to check for proper operation.



## SECTION 16B – TRANSAXLE (TYPE K)

---

### **▲ DANGER**

- See General Warning, Section 10, Page 10-1.

### **▲ WARNING**

- See General Warning, Section 10, Page 10-1.

## TRANSAXLE IDENTIFICATION

---

Club Car electric vehicles utilize one of two types of transaxles. The different transaxles are identified by the orientation of the gear case bolt heads:

- The Type G transaxle has gear case bolt heads oriented toward the passenger-side of the vehicle.
- The Type K transaxle has gear case bolt heads oriented toward the driver-side of the vehicle.

Please note that parts used in these transaxles are not interchangeable with one another. Determine which transaxle vehicle is equipped with before proceeding with service.

*This section pertains to Type K transaxles only.* For information and procedures on Type G transaxles, go to Section 16a – Transaxle (Type G).

## LUBRICATION

---

**See General Warning, Section 10, Page 10-1.**

There are two plugs located on the lower half of the transaxle housing. The upper plug (25) (as viewed when the vehicle is on a level surface), is used as a lubricant level indicator (**Figure 16b-4, Page 16b-3**). When the vehicle is parked on a level surface, the lubricant level should be even with the bottom of the hole. The lower plug (44) is for draining the lubricant. When draining the lubricant, the upper plug should be removed so the lubricant will drain faster. Be sure the drain plug is reinstalled before filling. **See following NOTE.**

**NOTE:** *Recycle or dispose of used oil or lubricant in accordance with local, state, and federal regulations.*

## AXLE BEARING AND SHAFT

---

**See General Warning, Section 10, Page 10-1.**

### AXLE SHAFT

#### Axle Shaft and Oil Seal Removal

1. Place chocks at the front wheels. Loosen lug nuts on rear wheels and lift the rear of the vehicle with a chain hoist or floor jack. Place jack stands under the axle tubes to support the vehicle.
2. Remove the rear wheel and brake drum. **See Section 6 – Wheel Brake Assemblies and Section 8 – Wheels and Tires in the appropriate maintenance and service manual.**

**Axle Shaft and Oil Seal Removal, Continued:**

3. Use 90° internal snap ring pliers to remove the internal retaining ring (6) from the axle tube (Figure 16b-4, Page 16b-3). See also Figure 16b-1, Page 16b-2.
4. Remove the axle, retaining ring, and bearing assembly by pulling the axle straight out of the housing.
5. Use a 16-inch (40 cm) rolling wedge bar (Figure 16b-2, Page 16b-2) to remove oil seal. Insert the wedge bar underneath the seal lip and pry out oil seal (17) (Figure 16b-3, Page 16b-2). See following CAUTION.

**CAUTION**

- Do not scar or damage the inside surfaces of the tube when removing the oil seal. A damaged tube might have to be replaced.
6. Inspect the axle shaft assembly to be sure the bearing and collar have not slipped and are still seated against the shoulder on the axle shaft.
  7. Inspect bearing (5) (Figure 16b-4, Page 16b-3). If the bearing is worn or damaged, replace it.

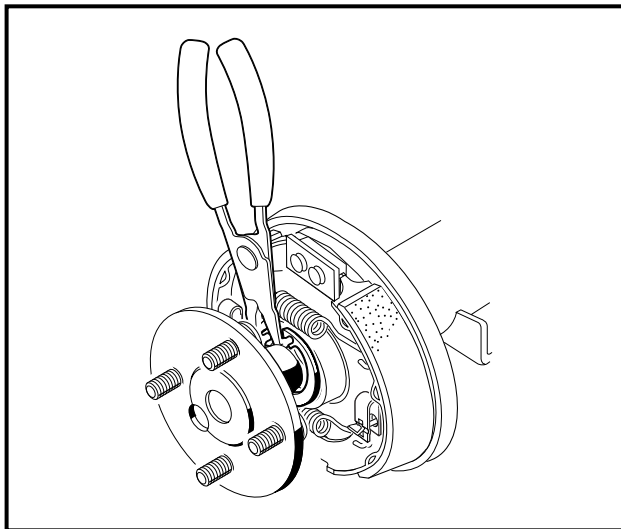

Figure 16b-1 Axle Tube

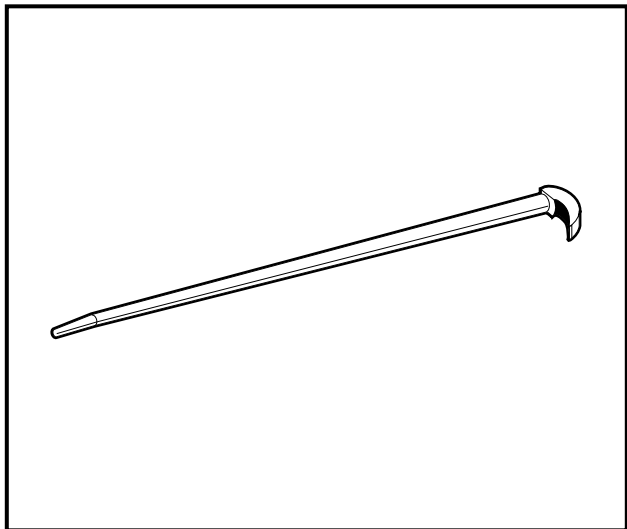

Figure 16b-2 Rolling Wedge Bar

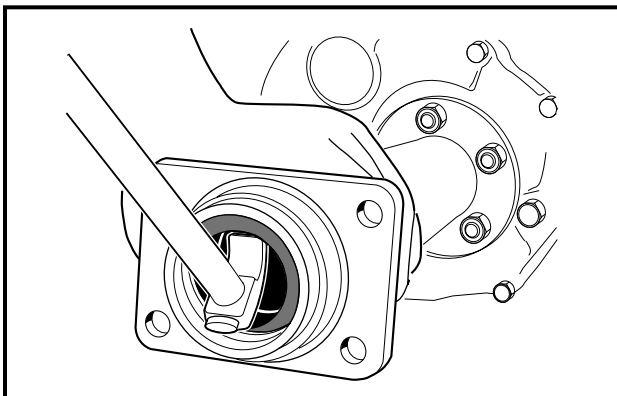

Figure 16b-3 Seal Lip

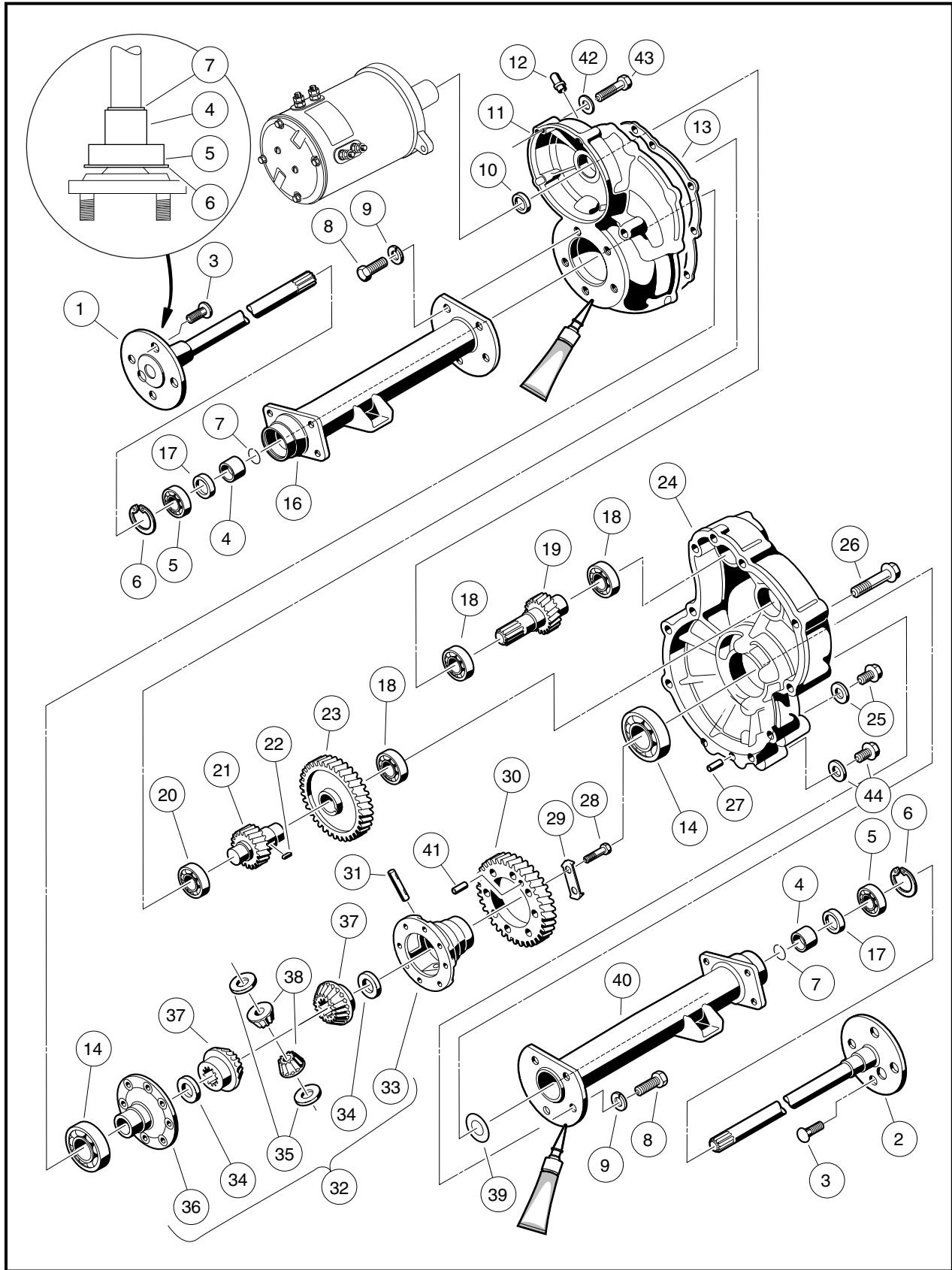

Figure 16b-4 Transaxle – Type K

## AXLE BEARING

### Axle Bearing Removal

1. Remove the retaining ring (7) from the axle shaft (**Figure 16b-4, Page 16b-3**).
2. Place a bearing puller wedge attachment (CCI P/N 1012812) on the axle shaft between the wheel mounting flange and the bearing.
3. Press bearing (5) and collar (4) off together (**Figure 16b-5, Page 16b-4**). See following **CAUTION** and **NOTE**.

### CAUTION

- Do not tighten the bearing puller wedge attachment against the axle shaft. This could damage the axle shaft when pressing off the bearing and collar.

**NOTE:** It may be necessary to heat the collar before the collar can be removed.

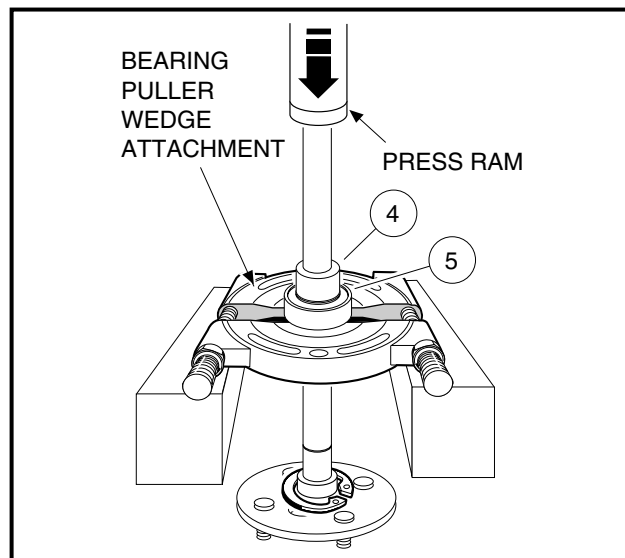

Figure 16b-5 Bearing and Collar

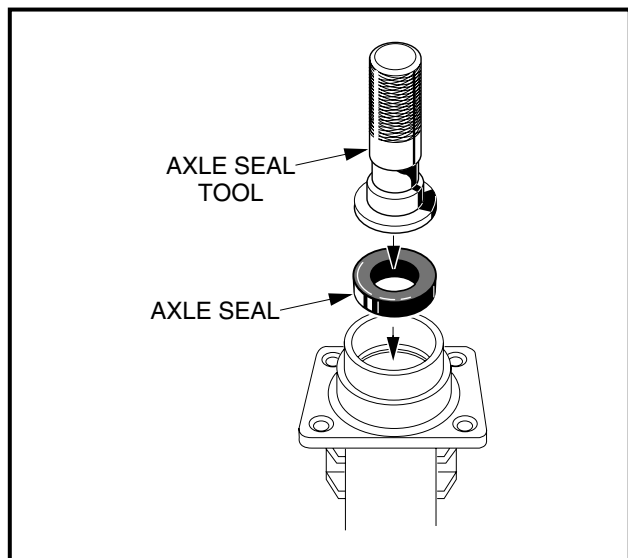

Figure 16b-6 Axle Seal Tool

### Axle Bearing Installation

1. If removed, place retaining ring (6) on axle shaft (1 or 2) (**Figure 16b-4, Page 16b-3**). The retaining ring will be loose on the axle shaft until it is installed into the axle tube.
2. Apply two drops of Loctite<sup>®</sup> 271 to the inside of the collar. See following **CAUTION**.

### CAUTION

- Apply Loctite<sup>®</sup> 271 to inside of collar only, not to the shaft, so the Loctite will be pushed away from the bearing as the collar and bearing are pressed on. If Loctite gets on or in the bearing, the bearing must be replaced.
  - The collar should be removed no more than two times. If a bearing is removed a third time, the shaft and collar will not give a proper fit.
3. Place the bearing and the collar on the shaft (note, this is a sealed bearing). See following **CAUTION**.

## **CAUTION**

- If the bearing was removed from the shaft, replace bearing with a new one.
4. Place the bearing puller wedge attachment against the collar and press on both the bearing and collar. See following CAUTION.

## **CAUTION**

- Do not tighten the bearing puller wedge attachment against the axle shaft. This could damage the axle shaft when pressing off the bearing and collar.
5. Install retaining ring (7) into the groove on the axle shaft (Figure 16b-4, Page 16b-3).

## **Axle Shaft and Oil Seal Installation**

1. Clean bearing and seal seats in the axle tube (16 or 40) (Figure 16b-4, Page 16b-3).
2. Place a new seal (17) in the axle tube with the seal lip facing away from the bearing. Use an axle seal tool (CCI P/N 1014162) and mallet to tap it in until it seats firmly in position (Figure 16b-6, Page 16b-4). A hydraulic press may also be used with the axle seal tool. See following CAUTION.

## **⚠ CAUTION**

- Clean any residual oil from the exposed end of the axle shaft and from the oil seal area prior to installing the axle shaft.
3. Clean the shaft splines and then insert the shaft, splined end first, through the seal and into the axle tube. Be careful not to damage the seal. Then advance the shaft through the inner bearing and rotate it to align the shaft splines with the splined bore of the differential side gear (37) (Figure 16b-4, Page 16b-3). Continue advancing the shaft until the bearing seats against the axle tube shoulder.
  4. Use a pair of snap ring pliers to install the retaining ring (6) inside axle tube (Figure 16b-4, Page 16b-3).
  5. Place a 1/4 to 3/8-inch (6 to 10 mm) diameter rod against the retaining ring and tap lightly at four to five locations around the retaining ring to ensure it is properly seated. See following WARNING.

## **⚠ WARNING**

- Be sure the retaining ring is properly seated in its groove. If the ring is not properly installed, the axle assembly will separate from the transaxle and damage the axle assembly and other components. Loss of vehicle control could result, causing severe personal injury.

## **TRANSAXLE**

---

See General Warning, Section 10, Page 10-1.

## **TRANSAXLE REMOVAL**

1. Place chocks at the front wheels and slightly loosen lug nuts on both rear wheels.

**Transaxle Removal, Continued:**

2. Place a floor jack under the transaxle and raise the rear of the vehicle. Position jack stands under the frame crossmember between the spring mount and the side stringer, just forward of each rear wheel. Lower the vehicle to let the jack stands support the vehicle (**Figure 16b-7, Page 16b-6**).
3. Remove the rear wheels, then thread one lug nut onto a stud on each rear hub. This will keep the brake drums on the hubs.
4. Remove the bow-tie pins (1), brake cable clevis pins (2), and cable retaining E-clips (3). Disconnect the brake cables (4) (**Figure 16b-8, Page 16b-6**).

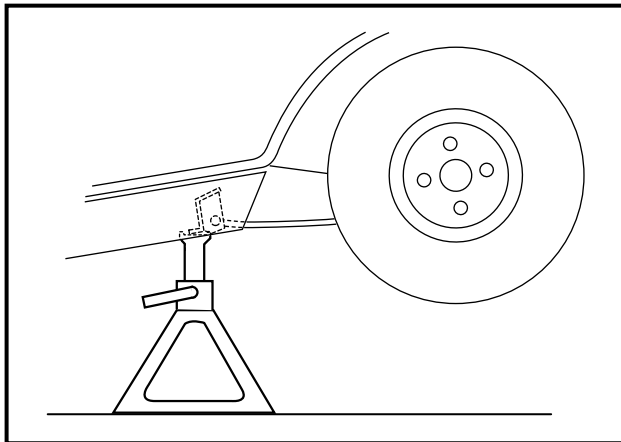

Figure 16b-7 Vehicle Supported on Jack Stands

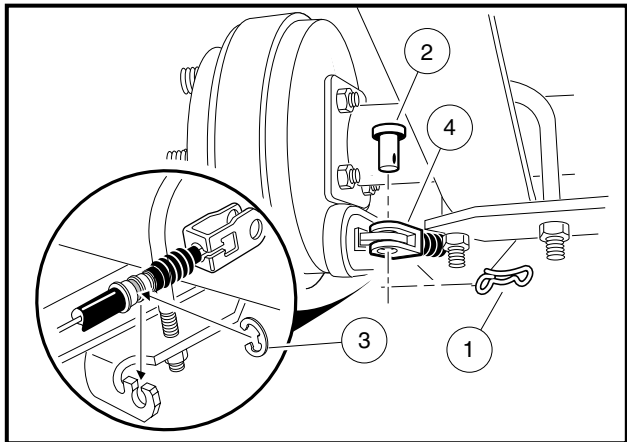

Figure 16b-8 Disconnect Brakes

5. Disconnect the shock absorbers from their lower mounts (**Figure 16b-9, Page 16b-6**).
6. Disconnect the four motor wires. Use two wrenches to prevent the post from turning.
7. With a floor jack supporting the transaxle, remove lower spring shackle nuts and bolts. Position shackles so they are clear of springs (**Figure 16b-10, Page 16b-6**).

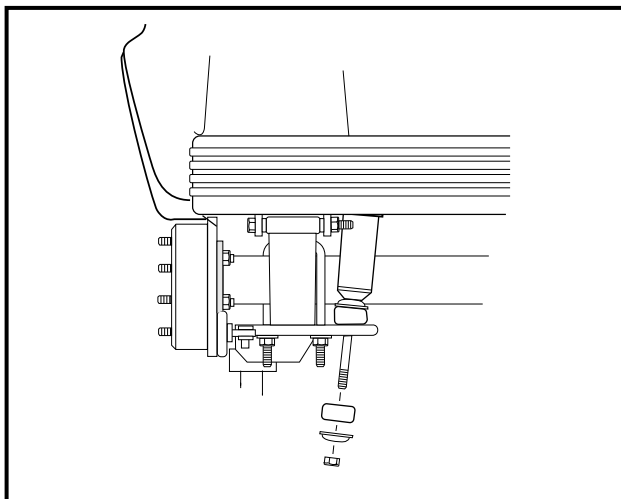

Figure 16b-9 Disconnect Shocks

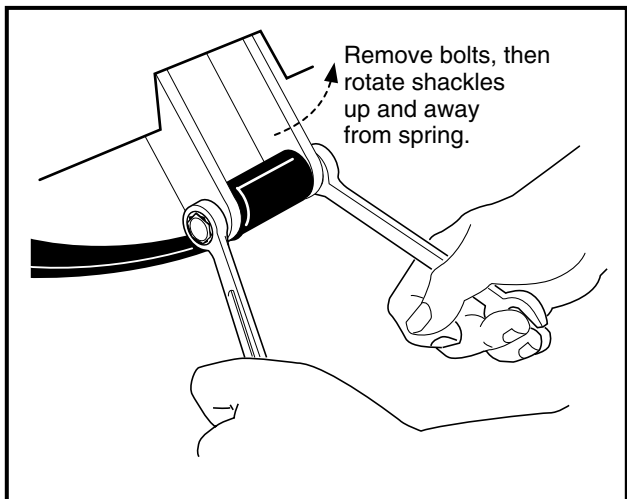

Figure 16b-10 Shackles



8. If a chain hoist was used to raise the vehicle, lift the vehicle high enough to permit easy access and clearance for removal of the motor. If a floor jack was used to raise the vehicle, lower the transaxle enough to permit easy access and clearance for removal of the motor.
9. Remove the three motor mounting bolts (**Figure 16b-12, Page 16b-7**), and the motor positioning bolt (**Figure 16b-13, Page 16b-8**) mounting the motor to the transaxle. **See following CAUTION.**

### **▲ CAUTION**

- **Do not position fingers under motor when sliding motor off of the input shaft. Fingers may get pinched when motor disengages.**

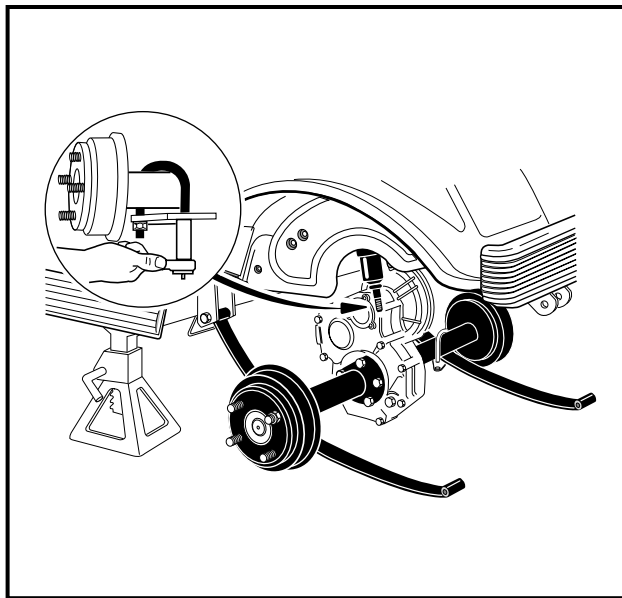

**Figure 16b-11 Leaf Springs**

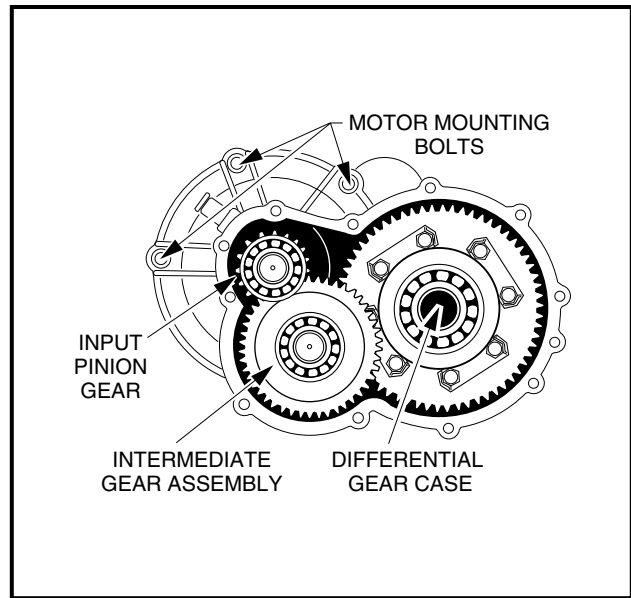

**Figure 16b-12 Motor Mounting Bolts**

10. Carefully remove the motor from the transaxle. Slide the motor away from the transaxle until the motor spline becomes disengaged from the input shaft, then lift motor out. **See preceding CAUTION.**
11. If a floor jack was used, pull floor jack from beneath the transaxle and allow the springs to rest on the floor.
12. Remove the U-bolts attaching the transaxle to the leaf springs (**Figure 16b-11, Page 16b-7**).
13. Carefully lift each end of the transaxle off its positioning pin (on the leaf spring) and slide the transaxle to the rear and out of the vehicle.
14. Drain the lubricant from the transaxle and remove the axle shafts. **See Axle Shaft and Oil Seal Removal on page 16b-1. See following NOTE.**

**NOTE:** *Recycle or dispose of used oil or lubricant in accordance with local, state, and federal regulations.*

15. Remove the brake assemblies if required. **See Section 6 – Wheel Brake Assemblies in the appropriate maintenance and service manual.**

**Transaxle Removal, Continued:**

Figure 16b-13 Motor Positioning Bolt

## TRANSAXLE DISASSEMBLY, INSPECTION, AND ASSEMBLY

---

See General Warning, Section 10, Page 10-1.

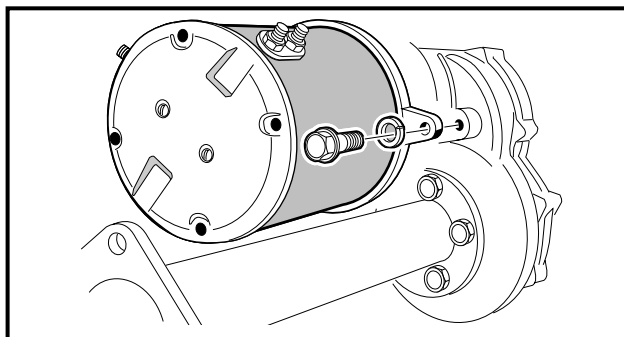
### TRANSAXLE DISASSEMBLY AND INSPECTION

1. To detach axle tubes (16 and 40) from the transaxle housing, remove the bolts and lock washers (8 and 9) (Figure 16b-4, Page 16b-3). See following NOTE.

**NOTE:** Shims are located between axle tube and differential case bearing. Do not damage shims. If shims are removed, set them aside for reinstallation.

2. Remove 10 bolts (26) that hold housing together.
3. Pull the halves of the housing (11 and 24) apart. If necessary, tap lightly on the spline of the input pinion (19). See following CAUTION.

#### **CAUTION**

- To prevent damage to the housing mating seal surfaces, use caution when separating halves.
4. Remove input pinion gear (19) by pulling gear out while rocking intermediate gear assembly (23). Lift intermediate gear assembly and differential gear case unit out simultaneously (Figure 16b-4, Page 16b-3). See following CAUTION.

#### **CAUTION**

- Do not damage gears. Use extreme care when handling them.
5. Use a bearing puller or arbor press to remove bearings (18) from the input pinion gear. If the oil seal (10) is damaged, replace it (Figure 16b-4, Page 16b-3). See also Figure 16b-14, Page 16b-9. See following CAUTION.

#### **CAUTION**

- Do not reuse bearings after removing them. Replace bearings with new ones.

6. To disassemble the intermediate gear assembly, press off together the bearing (18) and the gear (23) (**Figure 16b-4, Page 16b-3**). See also **Figure 16b-14, Page 16b-9**.
7. Remove key (22) (**Figure 16b-4, Page 16b-3**). See also **Figure 16b-15, Page 16b-9**.

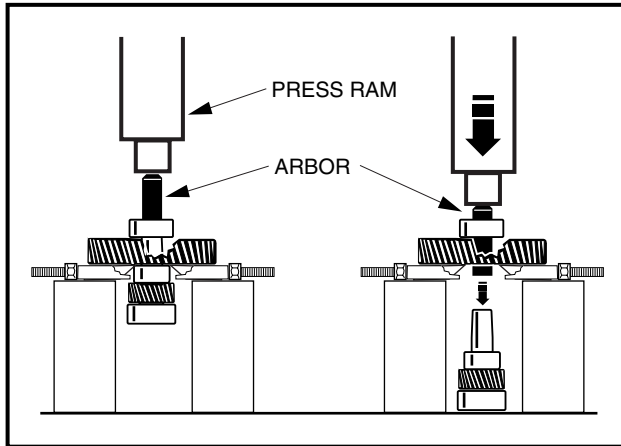

Figure 16b-14 Intermediate Gear Assembly

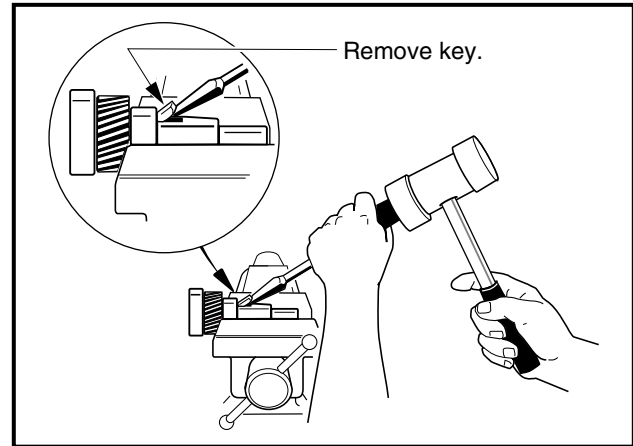

Figure 16b-15 Remove Key

8. Press the bearing (20) off the intermediate gear assembly (**Figure 16b-4, Page 16b-3**).
9. Disassemble the differential gear case:
  - 9.1. Bend the bolt lock plates (29) down onto the ring gear (30) (**Figure 16b-4, Page 16b-3**). See also **Figure 16b-16, Page 16b-9**.
  - 9.2. Remove eight hex bolts (28) that secure the ring gear to the differential case (**Figure 16b-4, Page 16b-3**).
  - 9.3. Remove the ring gear. Retain dowel pin (41) from between the ring gear and differential case for reassembly.
  - 9.4. Separate the differential gear case housing. If necessary, reinstall two of the hex bolts (removed previously in step 9.2) into the differential gear unit and, while holding the unit slightly above the work area, lightly tap the bolt heads (**Figure 16b-17, Page 16b-9**). Remove the two bolts.

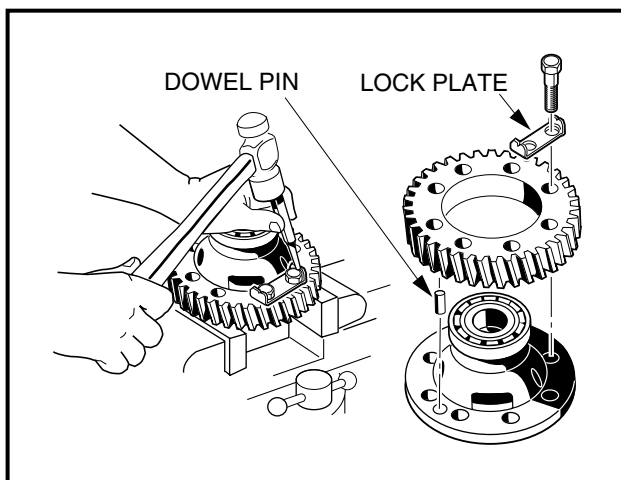

Figure 16b-16 Lock Plate

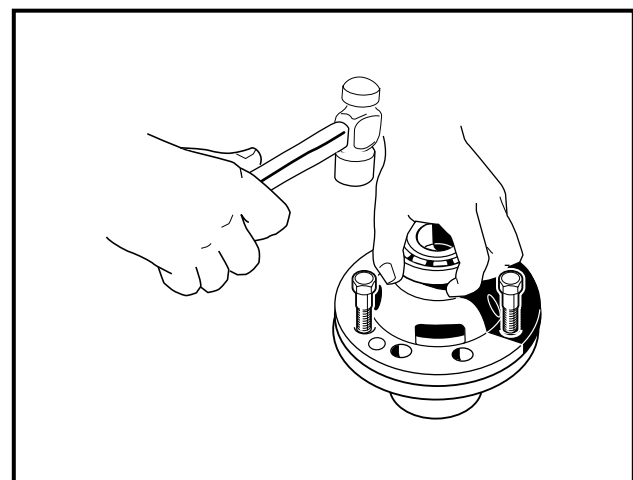

Figure 16b-17 Separate Housing

**Transaxle Disassembly and Inspection, Continued:**

- 9.5. Remove the differential pin (31) by pushing pin through differential gear case from one side (**Figure 16b-4, Page 16b-3**). See also **Figure 16b-18, Page 16b-10**.
- 9.6. Remove the idler gears and thrust plates (1 and 2) (**Figure 16b-19, Page 16b-10**).
- 9.7. Remove the differential gears and thrust plates (3 and 4) (**Figure 16b-19, Page 16b-10**).
- 9.8. Inspect the bearings (14) of the differential case (33 and 36) and replace them if they are damaged (**Figure 16b-4, Page 16b-3**). To remove them, press them off. See following **CAUTION**.

**CAUTION**

- Do not reuse bearings after removing them. Replace bearings with new ones.

10. Inspect parts for wear or damage. Any worn or damaged parts should be replaced. See following **NOTE**.

**NOTE:** Damaged or worn gears should be replaced as sets.

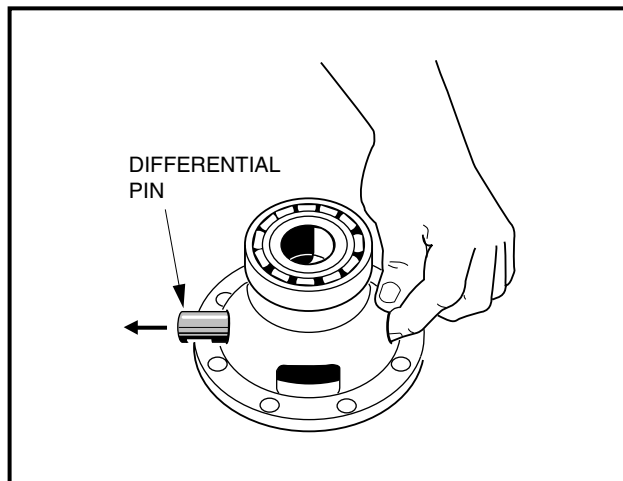

Figure 16b-18 Differential Pin

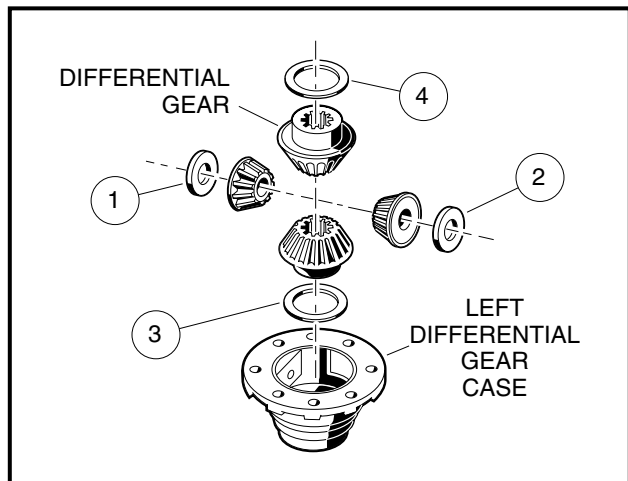

Figure 16b-19 Left Differential

**TRANSAXLE ASSEMBLY****CAUTION**

- Do not press against the bearing outer race.
- Gasket (13) faces of the housing must be clean and smooth. Use only a new gasket that is not torn or damaged. The gasket must lie flat against the housing faces (**Figure 16b-4, Page 16b-3**).
- The housing and all parts must be wiped clean and dry before reassembly.

1. If bearings (14) were removed during disassembly, install new bearings using an arbor press (**Figure 16b-4, Page 16b-3**).
2. Assemble the differential gear case.
  - 2.1. Install the pin (31) (**Figure 16b-4, Page 16b-3**). Apply a small amount of oil to all thrust plates and to both ends of the pin.
  - 2.2. While aligning the dowel pin, assemble the two halves of the differential gear case (33 and 36) and reinstall the output gear (30) (**Figure 16b-4, Page 16b-3**).

- 2.3. Install eight hex bolts (28) and the bolt lock plates (29). Tighten the bolts to 18 ft-lb (24 N·m).
  - 2.4. Bend the edges of the bolt locking tabs securely against the flats of the bolt heads to prevent the bolts from loosening and possibly causing damage (**Figure 16b-16, Page 16b-9**).
  - 2.5. If the large gear (23) was removed from the intermediate gear, insert key (22) into keyway in the shaft and then press the large gear and the bearing (18) onto the shaft. Be sure the key is properly positioned in the keyway before attempting to press on the large gear and bearing (**Figure 16b-4, Page 16b-3**).
  3. Press a new bearing (20) onto the intermediate gear assembly (**Figure 16b-4, Page 16b-3**).
  4. Press new bearing (18) onto input pinion gear (19).
  5. Apply grease to the lip of the new oil seal (10) and install the seal using a transaxle pinion seal tool (CCI P/N 1014161). The lip of the oil seal should face the inside of the transaxle housing. Make sure the seal is firmly seated.
  6. Install the differential assembly, the intermediate gear assembly, and the input pinion gear simultaneously. Be sure all bearings are seated properly in the housing. Rotate the input shaft to check for smooth gear operation (**Figure 16b-12, Page 16b-7**).
  7. Install both dowel pins (27) in the transaxle housing (24) (**Figure 16b-4, Page 16b-3**).
  8. Install left half of transaxle housing:
    - 8.1. Place a 1/8-inch (3 mm) bead of Three Bond liquid gasket on mating surface of housing.
    - 8.2. Install left half of transaxle housing (24) (**Figure 16b-4, Page 16b-3**).
    - 8.3. Install the ten bolts (26) and tighten to 69 in-lb (7.8 N·m).
    - 8.4. If the axle tube (16 and 40) was removed, install the shims (39) (if the shims were removed) and Three Bond liquid gasket. Install the axle tube with five lock washers and bolts (9 and 8). Tighten the bolts to 36 ft-lb (49 N·m). **See following NOTE.**
- NOTE:** If the differential case (33 and 36), the transaxle housing (11 and 24) or axle tube (16 and 40) (**Figure 16b-4, Page 16b-3**) was replaced, shim the transaxle. **See *Shimming the Transaxle on page 16b-12***.
9. Install the brake assemblies as instructed. **See Section 6 – Wheel Brake Assemblies in the appropriate maintenance and service manual.**
  10. Apply a small amount of grease to the lip of the oil seal (17) (**Figure 16b-4, Page 16b-3**). **See following CAUTION.**

### **⚠ CAUTION**

- **Clean any residual oil from the exposed end of the axle shaft and from the oil seal area prior to installing the axle shaft.**
11. Clean the splines on the axle shaft (1 and 2). Rotate the axle to align the shaft splines with the splined bore of the differential side gear. Push the shaft in until the bearing seats against the shoulder in the axle tube.
  12. Install the retaining ring (6) in the axle tube. **See following WARNING.**

### **⚠ WARNING**

- **Be sure the retaining ring is properly seated in its groove. If the ring is not properly installed, the axle assembly will separate from the transaxle and damage the axle assembly and other components. Loss of vehicle control could result, causing severe personal injury.**

**Transaxle Assembly, Continued:**

13. Make sure the drain plug (44) is installed in the transaxle and tightened to 23 ft-lb (31 N·m). Fill the transaxle, through the level indicator hole, with 22 ounces of SAE 30 API Class SE, SF, or SG oil (a higher grade may also be used). Install and tighten the level indicator plug (25) to 23 ft-lb (31 N·m).

**SHIMMING THE TRANSAXLE**

If the differential case (36 and 33), transaxle housing (11 and 24), or axle tube (16 and 40) has been replaced, the transaxle may need new shims. To determine whether new shims are necessary, the transaxle must be completely assembled except for the short axle tube (16) and both axle shafts (1 and 2) (**Figure 16b-4, Page 16b-3**).

1. Stand the transaxle on end, on the axle tube.
2. Using a depth gauge, measure the distance from the gasket seal surface of the axle tube to the outer race of the bearing (14) on the differential case assembly (32) (**Figure 16b-4, Page 16b-3**). See also **Figure 16b-20, Page 16b-12**.

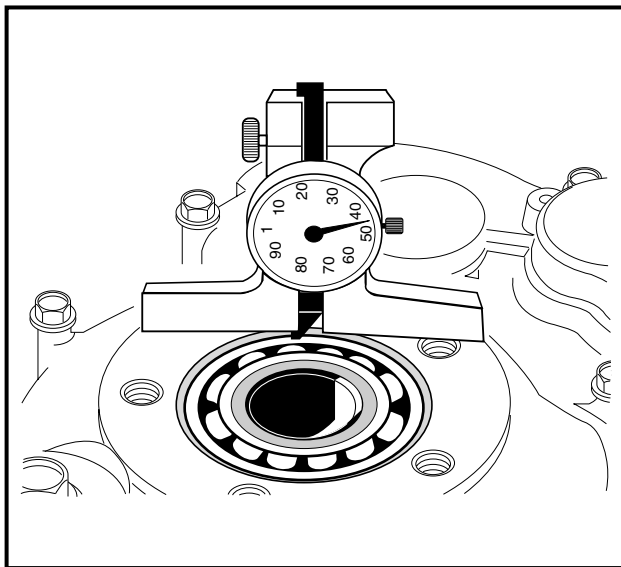

**Figure 16b-20 Depth Gauge**

3. Use the following chart to determine whether shimming is required and, if so, how many shims (CCI P/ N 1013781) should be used.

SEAL SURFACE MEASUREMENT	SHIMS REQUIRED
Up to 0.134 in. (3.4 mm)	0
0.134 -0.142 in. (3.4-3.6 mm)	1
0.142 -0.150 in. (3.6-3.8 mm)	2
0.150 -0.155 in. (3.8-3.9 mm)	3

## TRANSAXLE INSTALLATION

---

### See General Warning, Section 10, Page 10-1.

1. If using a chain hoist, raise the vehicle and place transaxle in position on the jack stands. If using a floor jack, lower the jack stands to their lowest settings and place the transaxle in position on the jack stands.
2. Align the center hole in the saddle of the transaxle with the pilot bolt in the leaf spring assembly.
3. Install the two U-bolts, jounce bumper mount (if required), and spacers, lock washers, and nuts. Tighten the nuts to 25 ft-lb (34 N·m). Tighten the U-bolt nuts so an equal amount of thread is visible on each leg of the bolt.
4. Install the motor. **See Section 15 – Motor.**
5. If using a chain hoist, lower the vehicle while guiding the leaf springs into the rear spring shackles. If using a floor jack, raise the differential while guiding the leaf springs into the rear spring shackles. Then raise the jack stands to support the transaxle.
6. Connect the four motor wires. Tighten the retaining nuts to 65 in-lb (7.3 N·m). Use two wrenches to prevent the posts from turning. **See following NOTE.**

**NOTE:** *If the motor wires were not tagged when disconnected, refer to the wiring diagram for proper connection. See Wiring Diagram, Section 11, Page 11-4.*

7. Insert bolts through the spring shackles and bushings in the leaf spring eyes. Secure bolts with lock nuts. Tighten to 15 ft-lb (20.3 N·m).
8. Connect the brake cables.
9. Install the shock absorbers. Tighten shock absorber retaining nuts until the rubber bushings expand to the same size as the cup washers.
10. Install the rear wheels and finger-tighten the lug nuts.
11. Lift the vehicle and remove the jack stands.
12. Lower vehicle and tighten the lug nuts, using a crisscross pattern, to 55 ft-lb (74.6 N·m).
13. Test drive the vehicle to check for proper operation.





**A****accelerator pedal limit switch**

- installation ..... 12-4
- removal ..... 12-4
- testing ..... 11-9

**armature**

see motor, armature

**B****batteries** ..... 13-1

- see also battery charger
- care ..... 13-4
- charge circuit ..... 11-2
- charging ..... 13-6
- deep discharge ..... 13-7
- electrolyte
  - adding water (mineral content) ..... 13-6
  - level ..... 13-5
- excessive early discharging ..... 13-7
- fleet rotation ..... 13-7
- hydrometer calibration ..... 13-10
- maintenance, preventive ..... 13-4
  - see also batteries, electrolyte
- misconceptions about batteries ..... 13-3
- replacement ..... 13-3
- self-discharge ..... 13-5
- storage ..... 13-14
- testing ..... 13-9
  - discharge test ..... 13-11
    - interpreting test results ..... 13-12
  - hydrometer test ..... 13-9
    - interpreting test results ..... 13-10
  - on-charge voltage test ..... 13-9
- troubleshooting examples ..... 13-13
- vibration damage ..... 13-6

**battery charger**

- AC service, incoming ..... 13-7
- charge circuit ..... 11-2
- numbering vehicles and chargers ..... 13-7
- testing ..... 13-9
  - on-charge voltage test ..... 13-9
- troubleshooting
  - automatic shut-off malfunction ..... 13-7

**bearing, axle**

- see transaxle, type g, axle bearing
- see transaxle, type k, axle bearing

**bearing, motor**

see motor

**brush, wiper switch**

see wiper switch

**C****charger receptacle**

- fuse link ..... 12-17
  - installation ..... 12-17
  - removal ..... 12-17
- inspection ..... 12-16
- installation ..... 12-17
- removal ..... 12-16
- testing ..... 12-16

**circuits, electrical**

see electrical system circuits

**D****differential**

- see transaxle, type g
- see transaxle, type k

**drive motor**

see motor

**drive unit**

- see transaxle, type g
- see transaxle, type k

**E****electric motor**

see motor

**electrical system circuits**

- charge circuit ..... 11-2
- circuit testing ..... 11-7
- control circuit ..... 11-1
- power circuit ..... 11-2

**F****forward/reverse anti-arcing limit switch**

- installation ..... 12-3
- removal ..... 12-3
- testing ..... 11-9

**forward/reverse switch**

- inspection ..... 12-14
- installation ..... 12-15
- removal ..... 12-15
- testing ..... 11-12

**I****inspection**

- motor
  - armature ..... 15-5
  - armature ground test ..... 15-6
  - bearing ..... 15-7
  - field windings ..... 15-6
  - motor components ..... 15-7
  - transaxle, type g ..... 16a-7

- transaxle, type k ..... 16b-8
- K**
- key switch**
- installation ..... 12-2
- removal ..... 12-1
- testing ..... 11-8
- L**
- limit switch, accelerator pedal**
- see* accelerator pedal limit switch
- lubrication**
- periodic lubrication schedule ..... 10-4
- transaxle, type g ..... 16a-1
- transaxle, type k ..... 16b-1
- M**
- maintenance**
- batteries ..... 13-4
- periodic lubrication schedule ..... 10-4
- periodic service schedule ..... 10-2
- motor** ..... 15-1
- armature ground test ..... 15-6
- armature inspection ..... 15-5
- assembly ..... 15-10
- bearing
- inspection ..... 15-7
- installation ..... 15-9
- removal ..... 15-9
- component inspection ..... 15-7
- disassembly ..... 15-4
- field winding inspection ..... 15-6
- installation ..... 15-11
- reconditioning ..... 15-9
- removal ..... 15-3
- service specifications ..... 15-10
- testing ..... 11-14
- see* test procedures, motor
- P**
- periodic lubrication schedule** ..... 10-4
- periodic service schedule** ..... 10-2
- R**
- receptacle**
- see* charger receptacle
- resistor**
- installation ..... 12-7
- removal ..... 12-6
- testing ..... 11-11
- reverse buzzer**
- installation ..... 12-4
- removal ..... 12-4
- testing ..... 11-10
- S**
- service schedule**
- see* periodic service schedule
- see also* periodic lubrication schedule
- snubber, solenoid**
- see* solenoid snubber
- solenoid** ..... 12-5
- installation ..... 12-5
- removal ..... 12-5
- testing ..... 11-10, 11-15
- solenoid snubber** ..... 12-6
- T**
- test procedures**
- 1 – batteries/voltage check ..... 11-8
- 2 – key switch ..... 11-8
- 3 – forward/reverse limit switch ..... 11-9
- 4 – accelerator pedal limit switch ..... 11-9
- 5 – solenoid activating coil ..... 11-10
- 6 – reverse buzzer ..... 11-10
- 7 – resistors ..... 11-11
- 8 – forward/reverse switch ..... 11-12
- 9 – motor ..... 11-14
- 10 – solenoid contacts (power off) ..... 11-15
- 11 – solenoid contacts (power on) ..... 11-15
- 12 – wiper switch ..... 11-16
- test procedures, motor**
- armature ground test ..... 15-6
- 1 – internal short circuits ..... 15-1
- 2 – armature circuit open ..... 15-2
- 3 – field circuit open ..... 15-2
- transaxle, type g**
- assembly ..... 16a-9
- axle bearing ..... 16a-4
- axle shaft
- installation ..... 16a-4
- removal ..... 16a-1
- disassembly ..... 16a-7
- identification ..... 16a-1
- inspection ..... 16a-7
- installation ..... 16a-10
- lubrication ..... 16a-1
- oil seal
- installation ..... 16a-4
- removal ..... 16a-1
- removal ..... 16a-5

**transaxle, type k**

assembly .....	16b-10
axle bearing .....	16b-4
installation .....	16b-4
removal .....	16b-4
axle shaft	
installation .....	16b-5
removal .....	16b-1
disassembly .....	16b-8
identification .....	16b-1
inspection .....	16b-8
installation .....	16b-13
lubrication .....	16b-1
oil seal	
installation .....	16b-5
removal .....	16b-1
removal .....	16b-5
shimming .....	16b-12

**troubleshooting**

batteries troubleshooting examples .....	13-13
troubleshooting guide .....	11-5

**W**

**water level**

see batteries, electrolyte level

<b>wiper switch</b> .....	12-8
adjustment .....	12-9
arm adjustment .....	12-8
assembly .....	12-11
brush replacement .....	12-10
disassembly .....	12-11
installation .....	12-12
removal .....	12-11
testing .....	11-16











**Golf Cars and Utility Vehicles**

---

Club Car Inc.

P.O. Box 204658

Augusta, GA 30917-4658