

2018 Carryall 500 and 700 Maintenance and Service Manual



**Gasoline Vehicle with Subaru EX40 Engine
Electric Vehicle with QuiQ™ Charger**

Manual Number 105344221
Edition Code B

FOREWORD

Club Car vehicles are designed and built to provide the ultimate in performance efficiency; however, proper maintenance and repair are essential for achieving maximum service life and continued safe and reliable operation.

This manual provides detailed information for the maintenance and repair of the 2018 Carryall 500 and Carryall 700 vehicles, and should be thoroughly reviewed prior to servicing the vehicle. The procedures provided must be properly implemented, and the DANGER, WARNING, and CAUTION statements must be heeded.

This manual was written for the trained technician who already possesses knowledge and skills in electrical and mechanical repair. *If the technician does not have such knowledge and skills, attempted service or repairs to the vehicle may render the vehicle unsafe.* For this reason, Club Car advises that all repairs and/or service be performed by an authorized Club Car distributor/dealer representative or by a Club Car factory-trained technician.

It is the policy of Club Car to assist its distributors and dealers in continually updating their service knowledge and facilities so they can provide prompt and efficient service for vehicle owners. Regional technical representatives, vehicle service seminars, periodic service bulletins, maintenance and service manuals, and other service publications also represent Club Car's continuing commitment to customer support.

Club Car offers a full line of training and continuing education classes for technicians who want to learn more about our products. For more information, contact your local dealer or Club Car's Technical Services department for a list of upcoming classes.

This manual covers all aspects of typical vehicle service; however, unique situations sometimes occur when servicing a vehicle. If it appears that a service question is not answered in this manual, please contact your nearest authorized Club Car dealer or distributor for assistance.

To find your local authorized Club Car dealer, visit www.clubcardealer.com, call 1-800-ClubCar (258-2227), or scan this Quick Response (QR) code to be taken to the Club Car dealer locator. Refer to Figure 1. Download a QR code reader such as RedLaser or Barcode Scanner to your cell phone or tablet.

If you would prefer to write to us, direct your letter to: Club Car LLC, Attention: Marketing Services, P.O. Box 204658, Augusta, Georgia 30917-4658 USA.

Dealer Locator QR Code



Copyright © 2018

Club Car is a registered trademark of Club Car, LLC

This manual effective January, 2018

FOREWORD

TECHNICAL PUBLICATION CUSTOMER SATISFACTION ONLINE SURVEY

Let your voice be heard!

Please participate in the Technical Publication customer satisfaction online survey. This survey takes less than five minutes to complete and your responses will help examine current performance and identify areas for future improvement.

Our top priority is to provide timely, accurate, and user friendly manuals.

The online survey can be found at <http://bit.ly/1w9uFMh> or using the QR Code below.

Online Survey QR Code



⚠ WARNING

- Read Safety on page 1-1 before attempting any service on the vehicle.
- Before servicing vehicle, read complete section(s) and any referenced information that may be relevant to the service or repair to be performed.

MAINTENANCE ITEMS	
Battery Terminal Protector Spray CC PN 1014305	Dry Moly Lube CC PN 1012151
Chassis Lube EP NLGI Grade 2 (commercially available)	Engine Air Filter (404 cc) CC PN 102558201
Deionizer Filter Replacement Cartridge (SPWS) CC PN 104005901	Spark Plug O.H.C. (404 cc) CC PN 105017801
Deionizer Filter Replacement Cartridge (non-SPWS) CC PN AM10975	

NOTE: This manual represents the most current information at the time of publication. Club Car is continually working to further improve its vehicles and other products. These improvements may affect servicing procedures. Any modification and/or significant change in specifications or procedures will be forwarded to all Club Car dealers and will, when applicable, appear in future editions of this manual.

Club Car reserves the right to change specifications and designs at any time without notice and without the obligation of making changes to units previously sold.

There are no warranties expressed or implied in this manual. See the limited warranty found in the vehicle Owner's Manual.

CONTENTS

SECTION 1 — Safety	1-1
<hr/>	
Safety Details	1-1
Personal Safety	1-1
Machine Safety.....	1-1
Information.....	1-1
General Warnings.....	1-1
Disabling the Vehicle.....	1-4
Disconnecting the Batteries – Electric Vehicles	1-4
Connecting the Batteries – Electric Vehicles	1-4
Disconnecting the Battery-Gasoline Vehicles	1-5
Connecting the Battery-Gasoline Vehicles	1-5
Recycling Lead-Acid Batteries	1-5
International safety symbols on batteries	1-5
SECTION 2 — Vehicle Specifications	2-1
<hr/>	
Vehicle Specifications	2-1
Vehicle Specifications – Electric Vehicles	2-1
QuiQ Battery Charger Specifications.....	2-3
Vehicle Specifications – Gasoline Vehicles	2-4
SECTION 3 — General Information	3-1
<hr/>	
Model Identification.....	3-1
Storage – Electric Vehicles	3-2
Preparing the Electric Vehicle for Extended Storage.....	3-2
Returning the Stored Electric Vehicle to Service	3-3
Storage – Gasoline Vehicles.....	3-4
Preparing the Gasoline Vehicle for Extended Storage	3-4
Returning the Stored Gasoline Vehicle to Service	3-5
SECTION 4 — Body and Trim	4-1
<hr/>	
Cleaning the Vehicle	4-1
Seat Cleaning.....	4-1
Front Body Repair	4-2
Light Scratches.....	4-2
Abrasions and Haze	4-2
Large Scratches and Abrasions	4-2
Touch-Up Paint Color Chart.....	4-2
Front Body	4-3
Heavy Duty Bumper Removal.....	4-3
Heavy Duty Bumper Installation.....	4-5
Cowl Removal	4-5
Cowl Installation	4-5
Grille Removal.....	4-6
Grille Installation.....	4-7
Front Bumper and Side Fender Removal	4-9
Front Bumper and Side Fender Installation.....	4-9
Instrument Panel Removal	4-10
Instrument Panel Installation	4-10
Dash Removal.....	4-11
Dash Installation.....	4-11
Tilt Bed	4-13
Tilt Bed Removal	4-13
Tilt Bed Installation	4-13
Bed Latch Assembly Removal	4-15
Bed Latch Assembly Installation	4-15
Rear Fenders and Tailskirt.....	4-17

Rear Fender and Tailskirt Removal	4-17
Rear Fender and Tailskirt Installation	4-18
Electric Bed Lift	4-19
Electric Bed Lift Removal	4-19
Electric Bed Lift Installation	4-19
Floor Mat	4-22
Floor Mat Removal	4-22
Floor Mat Installation.....	4-22
Trailer Hitch.....	4-22
Trailer Hitch Removal.....	4-22
Trailer Hitch Installation.....	4-22
SECTION 5 — Accelerator and Brake Pedal Group	5-1
<hr/>	
Brake Pedal and Park Brake (Gas and Electric Vehicles).....	5-1
Brake Pedal Removal (Gas and Electric Vehicles)	5-1
Brake Pedal Installation (Gas and Electric Vehicles).....	5-1
Park Brake Removal (Gas and Electric Vehicles).....	5-4
Park Brake Installation (Gas and Electric Vehicles)	5-4
Accelerator Pedal – Gasoline Vehicles	5-5
Accelerator Pedal Removal – Gasoline Vehicles.....	5-5
Accelerator Pedal Installation – Gasoline Vehicles	5-6
Accelerator Pedal – Electric Vehicles	5-7
Accelerator Pedal Removal – Electric Vehicles	5-7
Accelerator Pedal Installation – Electric Vehicles	5-10
Pedal Group Adjustment – Gasoline Vehicles	5-10
Pedal Group Adjustment – Electric Vehicles	5-16
SECTION 6 — Wheel Brake Assemblies	6-1
<hr/>	
General Information	6-1
Brake Shoe Removal	6-1
Brake Assembly Cleaning	6-3
Brake Shoe Installation	6-5
Brake Adjustment	6-6
Brake Cluster Adjustment.....	6-7
Brake Cable Equalization	6-9
Final Brake Cluster Adjustment.....	6-10
Test Drive Vehicle	6-10
Brake Cluster Removal and Installation.....	6-11
Front Brake Cluster Removal.....	6-11
Front Brake Cluster Installation.....	6-11
Rear Brake Cluster Removal	6-13
Rear Brake Cluster Installation	6-13
Front Brake Cables.....	6-14
Front Brake Cable Removal	6-15
Front Brake Cable Installation.....	6-15
Rear Brake Cables	6-16
Rear Brake Cable Removal.....	6-17
Rear Brake Cable Installation	6-17
SECTION 7 — Steering and Front Suspension	7-1
<hr/>	
General Information	7-1
Steering Wheel.....	7-1
Steering Wheel Removal.....	7-1
Steering Wheel Installation.....	7-2
Steering Column.....	7-3
Steering Column Removal.....	7-4
Steering Column Disassembly.....	7-4
Steering Column Assembly	7-4
Steering Column Installation.....	7-5
Steering Adjustment	7-6
Rack and Pinion	7-7

Rack and Pinion Inspection	7-7
Rack and Pinion Removal – Maintenance-Free Ball Joints	7-7
Rack and Pinion Disassembly	7-8
Rack and Pinion Assembly	7-10
Rack and Pinion Installation – Maintenance-Free Ball Joints	7-13
Tie Rod and Drag Link	7-14
Tie Rod and Drag Link Removal – Maintenance-Free Ball Joints	7-14
Tie Rod and Drag Link Installation – Maintenance-Free Ball Joints	7-14
Front Suspension	7-15
Lubrication	7-15
Wheel Alignment	7-15
Front Suspension Components	7-17
Leaf Spring Removal	7-17
Leaf Spring Installation	7-17
Kingpin and Steering Spindle Removal – Maintenance-Free Ball Joints	7-17
Kingpin and Steering Spindle Installation – Maintenance-Free Ball Joints	7-20
Delta A-Plate Removal	7-20
Delta A-Plate Installation	7-20
Shock Absorber Removal	7-20
Shock Absorber Installation	7-20
Front Wheel Bearings and Hubs	7-21
Front Wheel Free Play Inspection	7-21
Front Hub and Wheel Bearings Removal	7-21
Front Hub and Wheel Bearings Installation	7-22
SECTION 8 — Wheels and Tires	8-1
<hr/>	
General Information	8-1
Wheels	8-1
Wheel Removal	8-1
Wheel Installation	8-1
Tires	8-2
Tire Removal	8-2
Tire Repair	8-2
Tire Installation	8-3
SECTION 9 — Rear Suspension	9-1
<hr/>	
General Information	9-1
Shock Absorbers	9-1
Shock Absorber Inspection and Removal	9-1
Shock Absorber Installation	9-1
Multi-Leaf Springs	9-2
Multi-Leaf Spring Removal	9-2
Multi-Leaf Spring Installation	9-3
SECTION 10 — Periodic Maintenance	10-1
<hr/>	
General Information	10-1
Pre-Operation and Daily Safety Checklist	10-1
Performance Inspection	10-1
Maintenance	10-3
Periodic Service Schedules	10-4
Periodic Lubrication Schedules	10-7
SECTION 11 — Controller Diagnostic Tool (CDT)	11-1
<hr/>	
General Information	11-2
Features	11-2
Plugging the CDT into the Vehicle	11-2
Introductory Display	11-3
Quick Reference Guide – IQ Plus with Quiq Charger	11-4
System Info	11-5
Model Number	11-5

Serial Number	11-5
Hardware Version	11-5
Protocol Version	11-5
Param Block Version.....	11-5
MFG Date Code	11-5
OS Version.....	11-5
SM Version	11-5
VCL App Version	11-5
Parameters	11-5
Settings	11-6
Amp Hours.....	11-9
Access Codes	11-9
Vehicle ID	11-9
Monitor Menu	11-10
Speed In	11-10
Throttle %	11-11
Batt Voltage.....	11-11
Heatsink Temp	11-11
Mode	11-11
Arm Current	11-11
Field Current	11-11
Arm PWM	11-11
Field PWM	11-11
Foot Input	11-11
Key Input	11-11
Forward Input.....	11-11
Reverse Input.....	11-12
Mode Switch	11-12
WK Away Relay.....	11-12
Main Cont	11-12
Password Tries (OEM Access Level Only).....	11-12
Cir BRKR Open #	11-12
THRTL Fault #	11-12
Undervoltage #.....	11-12
Overvoltage #.....	11-12
Temp Cutback #	11-12
HPD #.....	11-12
Main Welded #	11-12
Relay Welded #	11-13
SPD Sensor #	11-13
Main DRV On #	11-13
Main Coil OPN #.....	11-13
Main Dropout #.....	11-13
Motor Stall #.....	11-13
Main DRVR Off#.....	11-13
Relay DNC #	11-13
Current Sense #	11-13
M-Shorted #	11-13
Relay Coil #.....	11-13
Precharge #	11-13
FLD Missing #	11-13
HW Failsafe #.....	11-13
DRVR Overcur #.....	11-14
RLY DRVR On #.....	11-14
RLY DRVR Off #.....	11-14
V min I.....	11-14
Signed Battery Current.....	11-14
BDI Percent.....	11-14
Charger Inhibit.....	11-14
LED Driver	11-14
Odometer.....	11-14
BDI Info	11-14
Battery Monitor.....	11-15
Charging Totals	11-15

Amp Hours Display	11-15
LIN	11-15
Diagnostics Menu	11-17
Present Errors Folder	11-17
Fault History Folder	11-17
System Faults	11-17
Fault Recovery	11-19
Fault Descriptions	11-20
01 Throttle Fault 1	11-20
02 Low Battery Voltage	11-20
03 Overvoltage	11-20
04 Thermal Cutback	11-20
06 HPD	11-20
07 Main Welded	11-20
08 Relay Welded	11-20
09 Speed Sensor	11-20
10 Main Driver On	11-20
11 Main Coil Open	11-20
12 Main Dropout	11-21
13 Motor Stall	11-21
14 Main Driver Off	11-21
15 Relay DNC	11-21
16 Keyswitch SRO	11-21
17 Current Sense	11-21
18 M- Shorted	11-21
20 Driver Overcurrent	11-21
21 Precharge Fault	11-21
22 Field Missing	11-21
23 Relay Driver On	11-21
24 HW Failsafe	11-21
25 Incorrect Password	11-22
26 Circuit BRKR Open	11-22
27 Max Password Tries	11-22
29 Relay DRVR Off	11-22
30 Relay Coil Fault	11-22
Anti-Tamper Fault	11-22
Lockout Fault	11-22
Low SOC	11-22
Main CONT DNC	11-23
Main Coil Fault	11-23
PROC/Wiring	11-23
Open Armature	11-23
Incorrect Password (OEM Access Level Only)	11-23
Fault History	11-23
Clearing Fault History	11-23
Programming	11-24
Cloning	11-24
Favorites	11-24
HHP Settings	11-25
Plot & Log	11-26
Plot	11-26
Log	11-26
CDT Troubleshooting	11-27
Connection Tests	11-28

SECTION 12 — Electrical System Troubleshooting: IQ Plus Electric Vehicles..... 12-1

General Information	12-1
Accessories	12-1
Charge Indicator Light	12-1
Key Differences: IQ Plus with QuiQ Charger vs. IQ Plus Charger	12-1
Features	12-2
Wiring Diagrams	12-4
Troubleshooting	12-8

Troubleshooting the Vehicle with the CDT	12-8
Troubleshooting Guide 1	12-9
Troubleshooting Guide 2	12-12
Test Procedures	12-14
Testing Basics	12-14
SECTION 13 — Electrical Components: IQ Plus Electric Vehicles.....	13-1
<hr/>	
Key Switch	13-1
Testing the Key Switch	13-1
Key Switch Removal	13-1
Key Switch Installation	13-1
Forward/Reverse Rocker Switch	13-3
Forward/Reverse Rocker Switch Removal	13-3
Forward/Reverse Rocker Switch Installation	13-3
Run/Tow Switch	13-3
Run/Tow Switch Removal	13-4
Run/Tow Switch Installation	13-4
Circuit Breaker	13-4
Circuit Breaker Removal	13-4
Circuit Breaker Installation	13-4
Motor Controller Output Regulator (MCOR)	13-6
Testing the MCOR	13-6
MCOR Removal	13-6
MCOR Installation	13-6
Reverse Buzzer	13-7
Reverse Buzzer Removal	13-7
Reverse Buzzer Installation	13-7
Speed controller cover	13-7
Removing the Speed Controller Cover	13-7
Installing the Speed Controller Cover	13-7
Solenoid	13-8
Solenoid Removal	13-8
Solenoid Installation	13-8
Speed Controller	13-9
Speed Controller Removal	13-9
Speed Controller Installation	13-9
Charge Indicator Light	13-11
Testing the Charge Indicator Light	13-11
Charge Indicator Light Removal	13-11
Charge Indicator Light Installation	13-11
SECTION 14 — Batteries: IQ Plus Electric Vehicles.....	14-1
<hr/>	
General Information	14-1
Battery Testing Basics – 6 Volt	14-2
Observation	14-2
Measuring Voltage of Battery Set	14-2
Battery Cell Numbering	14-2
Battery Testing – 6 Volt	14-3
Battery Regrouping	14-3
Battery Replacement	14-5
Battery Care	14-6
Water Quality	14-6
Deionizer	14-7
Battery Care – Vehicles Equipped with the Single-Point Watering System (SPWS)	14-8
Battery Care – Vehicles Without the Single-Point Watering System (SPWS)	14-9
Self-Discharge	14-10
Electrolyte Level	14-10
Vibration Damage	14-11
Single Point Watering System (SPWS)	14-11
Initial Maintenance of the SPWS	14-11
Watering Batteries with the SPWS	14-11
Battery Storage	14-13

Fleet Rotation	14-13
Deep-Discharge	14-14
Early Excessive Discharging	14-14
SECTION 15 — QuiQ High Frequency Charger	15-1
General Information	15-1
Features	15-1
UL and CSA Listing	15-1
CE Compliance	15-1
IP (Ingress Protection) Rating	15-1
How To Identify Charge Algorithm Number	15-2
How To Change The Algorithm	15-3
The Charge Circuit	15-3
Onboard Charger Operation	15-4
Charger Displays	15-6
AC Power Connection	15-8
Charging Batteries	15-8
Maintenance	15-9
Troubleshooting	15-10
Test Procedures	15-11
Charger Repairs	15-12
Onboard Charger Removal And Installation	15-12
Onboard Charger Removal	15-12
Onboard Charger Installation	15-13
SECTION 16 — Motor (Model DA5-4006): Electric Vehicles	16-1
General Information	16-1
External Motor Testing	16-1
Motor Removal	16-2
Motor Disassembly	16-4
Motor Component Testing and Inspection	16-7
Armature Inspection and Testing	16-7
Motor Frame and Field Windings Inspection	16-8
Motor Brush, Spring, and Terminal Insulator Inspection	16-8
Reconditioning the Motor	16-11
Motor Specifications	16-11
Motor Assembly	16-11
Motor Installation	16-13
SECTION 17 — Transaxle: Electric Vehicles	17-1
Lubrication	17-1
Axle Bearing and Shaft	17-1
Axle Shaft	17-1
Axle Bearing	17-4
Transaxle	17-5
Transaxle Removal	17-5
Transaxle Disassembly, Inspection, and Assembly	17-8
Transaxle Disassembly and Inspection	17-8
Transaxle Assembly	17-10
Transaxle Installation	17-12
SECTION 18 — Troubleshooting and Electrical System: Pedal-Start Gas Vehicle	18-1
General Information	18-1
Accessories	18-1
Low Oil Warning Light	18-1
Ground Locations	18-1
Features of the Electronic Fuel Injection (EFI) System	18-2
Troubleshooting Guide	18-2
ECU Error Codes (Displayed by the Low Oil Warning Light)	18-2
Gasoline Powertrain	18-4

Wiring Diagrams	18-8
Electrical System	18-14
Test Procedures	18-15
Testing Basics	18-15
SECTION 19 — Troubleshooting and Electrical System: Key-Start Gas Vehicle.....	19-1
<hr/>	
General Information	19-1
Wiring Diagrams	19-2
Test Procedures	19-6
SECTION 20 — Electrical Components: Pedal-Start Gas Vehicle	20-1
<hr/>	
Starter/Generator.....	20-1
Starter/Generator Removal	20-1
Disassembly of the Starter/Generator to Service the Brushes	20-1
Brush Inspection and Replacement.....	20-2
Brush Spring Inspection and Replacement.....	20-2
Starter/Generator Assembly	20-3
Disassembly of the Starter/Generator to Service the Armature/Commutator	20-4
Bearing Cleaning and Inspection	20-5
Bearing Removal	20-6
Field Coil Assembly	20-6
Visual Inspection of Armature	20-6
Commutator Cleaning and Inspection	20-7
Armature Ground Test.....	20-8
Visual Inspection of Field Coils	20-9
Starter/Generator Rework	20-9
Starter/Generator Assembly	20-9
Starter/Generator Installation.....	20-12
Belt Tension Adjustment for EFI Engines.....	20-13
Voltage Regulator.....	20-15
Voltage Regulator Removal.....	20-15
Voltage Regulator Installation.....	20-16
Engine Control Unit (ECU)	20-17
Engine Control Unit Removal.....	20-17
Engine Control Unit Installation.....	20-17
Key Switch.....	20-18
Key Switch Removal.....	20-18
Key Switch Installation	20-18
Maintenance/Operate Switch.....	20-19
Maintenance/Operate Switch Removal.....	20-19
Maintenance/Operate Switch Installation.....	20-19
Neutral Lockout Limit Switch	20-19
Neutral Lockout Limit Switch Removal	20-19
Neutral Lockout Limit Switch Installation.....	20-19
Solenoid.....	20-20
Solenoid Removal	20-20
Solenoid Installation.....	20-20
Fuse.....	20-20
Fuse Removal	20-21
Fuse Installation	20-21
Kill Limit Switch	20-22
Kill Limit Switch Removal	20-22
Kill Limit Switch Installation	20-22
Reverse Warning Buzzer.....	20-23
Reverse Warning Buzzer Removal	20-23
Reverse Warning Buzzer Installation.....	20-23
Reverse Buzzer Limit Switch	20-25
Reverse Buzzer Limit Switch Removal.....	20-25
Reverse Buzzer Limit Switch Installation	20-25
Low Oil Warning Light	20-27
Low Oil Warning Light Removal.....	20-27
Low Oil Warning Light Installation	20-27

Fuel Gauge/Hour Meter	20-27
General Information	20-27
Fuel Gauge/Hour Meter Removal	20-27
Fuel Gauge/Hour Meter Installation	20-28
Fuel Level Sending Unit	20-28
Oil Level Sensor	20-28
Oil Level Sensor Removal	20-28
Oil Level Sensor Installation	20-28
Voltage Limiter	20-28
Voltage Limiter Removal	20-29
Voltage Limiter Installation	20-29
Headlight Switch	20-30
Headlight Switch Removal	20-30
Headlight Switch installation	20-30
Headlights	20-30
Headlight Bezel Removal	20-30
Headlight Bezel Installation	20-30
Headlight Bulb Removal (Halogen)	20-31
Headlight Bulb Installation (Halogen)	20-31
Headlight Bulb Removal (LED)	20-31
Headlight Bulb Installation (LED)	20-31
Battery	20-33
General Information	20-33
Testing the Battery	20-33
Preventive Maintenance	20-33
Self-Discharge	20-34
Vibration Damage	20-34
Battery Removal	20-35
Charging the Battery	20-35
Battery Installation	20-35
Battery Storage	20-36
Charging a Dead Battery	20-36
Ground Cables	20-36

SECTION 21 — Electrical Components: Key-Start Gas Vehicle 21-1

General Information	21-1
Key Switch	21-1
Key Switch Removal	21-1
Key Switch Installation	21-2
Maintenance/Operate Switch	21-3
Maintenance/ Operate Switch Removal	21-3
Maintenance/Operate Switch Installation	21-3
Solenoid	21-3
Solenoid Removal	21-3
Solenoid Installation	21-3
Charging Diode	21-4
Charging Diode Removal	21-4
Charging Diode Installation	21-5

SECTION 22 — Engine (Subaru EX40) 22-1

General Information	22-1
Before Servicing	22-1
Engine Rotation	22-1
Torque Specifications	22-2
Adjustments and Settings	22-2
Engine Oil – Gasoline Vehicle	22-2
Spark Plug	22-5
Breather	22-6
Valve Clearance Check and Adjustment	22-7
Engine Removal	22-8
Engine Installation	22-9
Flywheel	22-10

Flywheel Removal	22-10
Flywheel Installation	22-11
Oil Level Sensor	22-12
Testing the Oil Level Sensor	22-12
Oil Level Sensor Removal	22-12
Oil Level Sensor Installation	22-12
Ignition Coil	22-13
Testing the Ignition Coil	22-13
Ignition Coil Removal	22-13
Ignition Coil Installation	22-13
Snubber	22-14
Snubber Removal	22-14
Snubber Installation	22-14
SECTION 23 — Fuel System: Gasoline Vehicles	23-1
<hr/>	
General Information	23-1
EFI System Features/Specifications	23-1
Relieving Fuel Pressure	23-2
To Relieve Fuel Pressure	23-2
Throttle Body	23-3
Throttle Body Removal	23-3
Throttle Body Installation	23-4
Engine Control Linkages	23-6
General Information	23-6
Ground Speed	23-7
Accelerator Rod	23-7
Governor Cable	23-9
Accelerator Cable	23-11
Closed Throttle or Idle Adjustment – Pedal-Start Vehicles	23-12
Closed Throttle or Idle Adjustment – Key-Start Vehicles	23-12
How to Measure Ground Speed	23-13
Engine RPM Adjustment	23-13
Air Intake System	23-14
Air Filter	23-15
Air Cleaner Removal	23-15
Air Cleaner Installation	23-15
Fuel Line	23-16
Fuel Line Removal	23-16
Fuel Line Installation	23-17
Fuel Pump Module	23-18
General Information	23-18
Fuel Pump Module Removal	23-18
Fuel Pump Module Installation	23-18
Fuel Tank	23-21
General Information	23-21
Fuel Tank Removal	23-21
Fuel Tank Disposal	23-22
Fuel Tank Storage	23-22
Fuel Tank Installation	23-22
Fuel Filter	23-23
General Information	23-23
Fuel Filter Removal	23-23
Fuel Filter Installation	23-24
Fueling Instructions – Gasoline Vehicle	23-24
SECTION 24 — Exhaust System: Gasoline Vehicles	24-1
<hr/>	
Muffler	24-1
Muffler Removal	24-1
Muffler Installation	24-1

SECTION 25 — Clutches: Gasoline Vehicles	25-1
<hr/>	
General Information	25-1
Troubleshooting.....	25-1
Drive Belt	25-3
Drive Belt Removal	25-3
Drive Belt Installation	25-3
Drive Clutch	25-4
Drive Clutch Removal	25-5
Drive Clutch Cleaning and Inspection.....	25-6
Drive Clutch Disassembly.....	25-7
Inspection of Drive Clutch Parts.....	25-9
Drive Clutch Assembly	25-10
Drive Clutch Installation	25-11
Driven Clutch	25-12
Driven Clutch Removal	25-13
Driven Clutch Disassembly.....	25-13
Driven Clutch Inspection	25-14
Driven Clutch Assembly	25-14
Driven Clutch Installation.....	25-16
SECTION 26 — Transaxle (ED65): Gasoline Vehicles	26-1
<hr/>	
General Information	26-1
Shifter Lever.....	26-1
Neutral Lockout	26-1
Governor System.....	26-2
Transaxle Service	26-2
Lubrication	26-2
Tools Required For This Section	26-3
Rear Hubs.....	26-4
Rear Hub Removal	26-4
Rear Hub Installation	26-4
Axle Tubes, Axle Shafts and Wheel Bearings	26-6
Axle Tube and Axle Shaft Removal	26-6
Axle Tube and Axle Shaft Installation	26-7
Rear Wheel Bearing Removal	26-7
Rear Wheel Bearing Installation.....	26-7
Axle Shaft Oil Seal Removal.....	26-7
Axle Shaft Oil Seal Installation.....	26-8
Transaxle Removal.....	26-9
Transaxle Installation	26-13
Shifter Cable	26-13
Shifter Cable Removal	26-13
Shifter Cable Installation	26-14
Shifter Cable Adjustment.....	26-14
Index	Index-1
<hr/>	

SAFETY DETAILS

To ensure the safety of those servicing Club Car vehicles, and to protect the vehicles from possible damage resulting from improper service or maintenance, the procedures in this manual must be followed.

It is important to note that throughout this manual there are statements labeled DANGER, WARNING, or CAUTION. These special statements relate to specific safety issues, and must be read, understood, and heeded before proceeding with procedures. There are statements labeled NOTE, which provide other essential service or maintenance information.

PERSONAL SAFETY

DANGER

- A DANGER indicates an immediate hazard that will result in severe personal injury or death. The color associated with Danger is RED.

WARNING

- A WARNING indicates an immediate hazard that could result in severe personal injury or death. The color associated with Warning is ORANGE.

CAUTION

- A CAUTION with the safety alert symbol indicates a hazard or unsafe practice that could result in minor personal injury. The color associated with Caution is YELLOW.

MACHINE SAFETY

CAUTION

- A CAUTION without the safety alert symbol indicates a potentially hazardous situation that could result in property damage.

A CAUTION, without the safety alert symbol, is intended for machine and property safety. It is used throughout this manual followed by specific instructions to prevent machine or property damage. Failure to follow these CAUTION messages could result in machine or property damage.

INFORMATION

NOTE: Instructions that clarify steps, procedures, or other information in this manual.

GENERAL WARNINGS

The following safety statements must be heeded whenever the vehicle is being operated, repaired, or serviced. Other specific safety statements appear throughout this manual and on the vehicle.

DANGER

- **Battery – Explosive gases! Do not smoke. Keep sparks and flames away from the vehicle and service area. Ventilate when charging or operating vehicle in an enclosed area. Wear a full face shield and rubber gloves when working on or near batteries.**
- **Gasoline – Flammable! Explosive! Do not smoke. Keep sparks and flames away from the vehicle and service area. Service only in a well-ventilated area.**
- **Do not operate engine in an enclosed area without proper ventilation. The engine produces carbon monoxide, which is an odorless, deadly poison.**
- **The vehicle will not provide protection from lightning, flying objects, or other storm-related hazards. If caught in a storm while driving a Club Car vehicle, exit the vehicle and seek shelter in accordance with applicable safety guidelines for your location.**

WARNING

- **Follow the procedures exactly as stated in this manual, and heed all DANGER, WARNING, and CAUTION statements in this manual as well as those on the vehicle and battery charger.**
- **Do not leave children unattended in vehicle at any time.**
- **Prior to leaving the vehicle unattended or servicing the vehicle, set the park brake, place the Forward/Reverse handle or switch in the NEUTRAL position, turn the key switch to the OFF position, and remove the key. Chock the wheels when servicing the vehicle.**
- **Improper use of the vehicle or failure to properly maintain it can result in decreased vehicle performance, severe personal injury, or death.**
- **Any modification or change to the vehicle that affects the electrical system, stability or handling of the vehicle, or increases maximum vehicle speed beyond factory specifications, can result in severe personal injury or death.**
- **Check the vehicle for proper location of all vehicle safety and operation decals and make sure they are in place and are easy to read.**
- **For vehicles with cargo beds, remove all cargo (including accessories) before raising the bed or servicing the vehicle. If the vehicle is equipped with a prop rod, ensure that it is securely engaged while bed is raised. Do not close bed until all persons are clear of cargo bed area. Keep hands clear of all crush areas. Do not drop cargo bed; lower gently and keep entire body clear. Failure to heed this warning can result in severe personal injury or death.**
- **Only trained technicians should service or repair the vehicle or battery charger. Anyone doing even simple repairs or service should have knowledge and experience in electrical and mechanical repair. The appropriate instructions must be used when performing maintenance, service, or accessory installation.**

Electric vehicles only:

- **Ensure battery connections are clean and properly tightened. See Battery Care – Vehicles Equipped with the Single-Point Watering System (SPWS) on page 14-8 or Battery Care – Vehicles Without the Single-Point Watering System (SPWS) on page 14-9.**
- **Place Run/Tow switch in the TOW position before disconnecting or connecting the batteries. Failure to heed this warning can result in a battery explosion or severe personal injury.**

WARNING CONTINUED ON NEXT PAGE

⚠ WARNING

- To avoid unintentionally starting an electric vehicle, disconnect the batteries and discharge the controller. See *Disconnecting the Batteries – Electric Vehicles* on page 1-4.

Gasoline vehicles only:

- To avoid unintentionally starting a gasoline vehicle, disconnect the battery and spark plug wire. See *Disconnecting the Battery-Gasoline Vehicles* on page 1-5.
- **Frame ground – Do not allow tools or other metal objects to contact frame when disconnecting battery cables or other electrical wiring. Do not allow a positive wire to touch the vehicle frame, engine, or any other metal component.**

All vehicles:

- **Wear safety glasses or approved eye protection when servicing the vehicle or battery charger. Wear a full face shield and rubber gloves when working on or near batteries.**
- **Do not wear loose clothing or jewelry such as rings, watches, chains, etc., when servicing the vehicle or battery charger.**
- **Use insulated tools when working near batteries or electrical connections. Use extreme caution to avoid shorting of components or wiring.**

DISABLING THE VEHICLE

1. Engage park brake to lock wheels.
2. Turn the key switch OFF and remove the key.
3. Place the Forward/Reverse control in the NEUTRAL position.
4. In addition, chock the wheels if servicing or repairing the vehicle.

DISCONNECTING THE BATTERIES – ELECTRIC VEHICLES

1. Disable the vehicle. **See Disabling the Vehicle on page 1-4.**
2. Place Run/Tow switch in the TOW position before disconnecting or connecting the batteries. Failure to heed this warning can result in a battery explosion or severe personal injury.
3. Disconnect the batteries, negative (-) cable first, as shown (**Figure 1-1**).
4. After disconnecting the batteries, wait 90 seconds for the controller capacitors to discharge.

CONNECTING THE BATTERIES – ELECTRIC VEHICLES

1. Ensure the Run/Tow switch is in the TOW position.
2. Connect the battery cables, positive (+) cable first.
3. Tighten battery terminals to 110 in·lb (12.4 N·m).
4. Coat terminals with Battery Terminal Protector Spray to minimize corrosion.

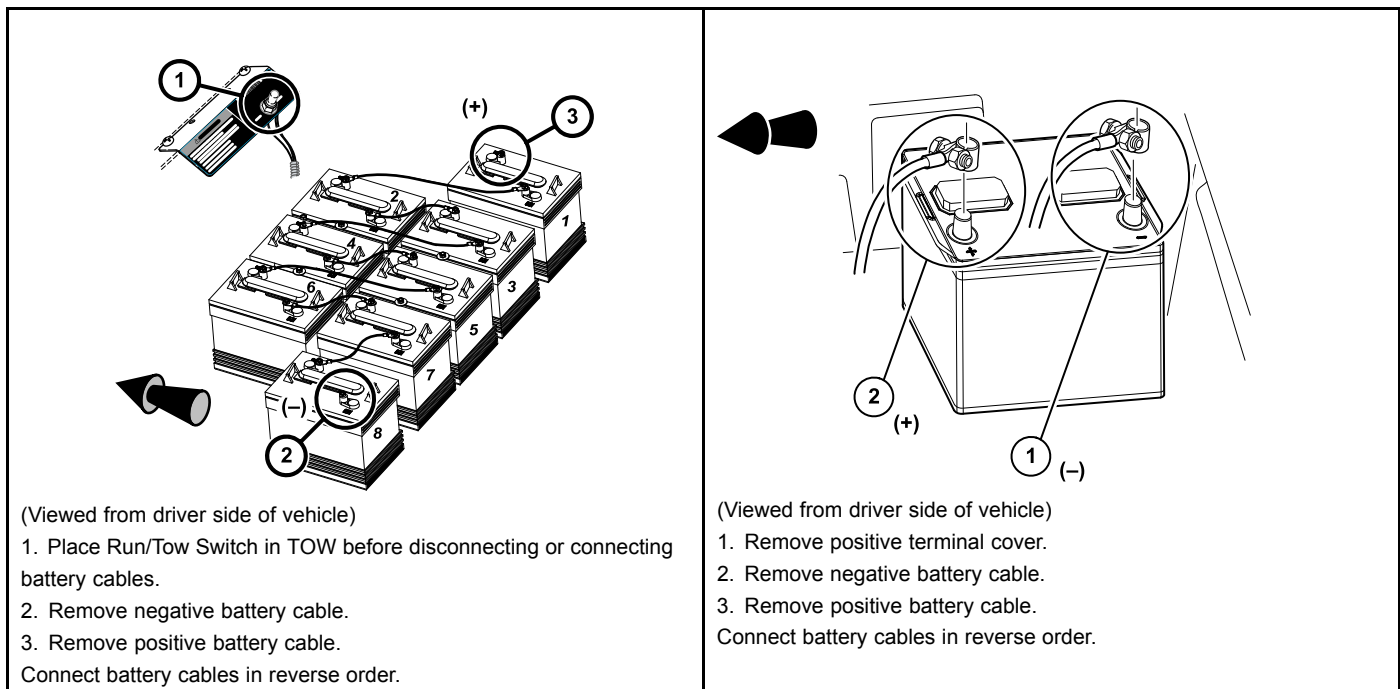

2780

Figure 1-1 Battery Cable Removal – Electric Vehicle

3167

Figure 1-2 Top-Post Battery- Battery Cable Removal-Gasoline Vehicles

DISCONNECTING THE BATTERY-GASOLINE VEHICLES

1. Disable the vehicle. **See Disabling the Vehicle on page 1-4.**
2. Remove positive terminal cover.
3. Disconnect the battery cables, negative (–) cable first, as shown (**Figure 1-2**).
4. Disconnect the spark plug wire(s) from the spark plug(s).

CONNECTING THE BATTERY-GASOLINE VEHICLES

1. Connect the battery cables, positive (+) cable first.
2. Tighten battery terminals to 41 in·lb (4.3 N·m).
3. Coat terminals with Battery Terminal Protector Spray (CC P/N 1014305) to minimize corrosion.
4. Attach positive terminal cover.
5. Connect the spark plug wire(s) to the spark plug(s).

RECYCLING LEAD-ACID BATTERIES

⚠ WARNING

- **Lead-acid batteries contain lead (Pb), other metals, acids and other compounds. If improperly handled, they can contaminate both water and soil, causing environmental damage and personal injury.**

Lead-acid batteries are identified by the symbol shown below and should be properly recycled (**Figure 1-3**). They cannot be disposed as municipal waste and must be collected separately. Responsibility for environmental protection must be shared, not only by the manufacturers of the batteries, but by people who use the batteries as well. Please contact your nearest Club Car dealer or distributor for information on how to properly recycle your batteries.

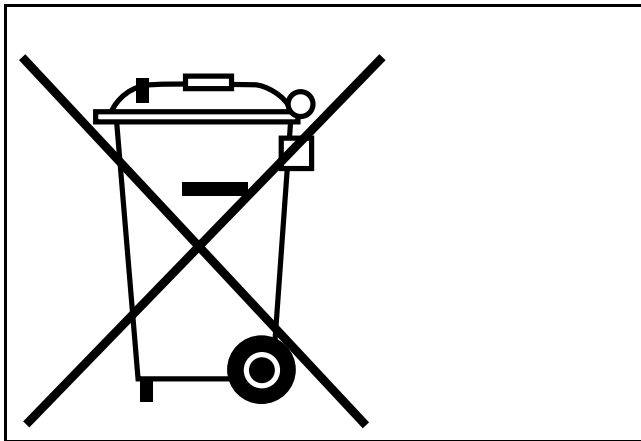

1403

Figure 1-3 Dispose of Lead-acid Batteries Properly

INTERNATIONAL SAFETY SYMBOLS ON BATTERIES

Anyone using, repairing, or servicing the vehicle must understand and heed the safety symbols on the vehicle battery or batteries.



1. Shield eyes.	3. No smoking, no open flames, no sparks.	5. Battery acid hazard.
2. Read and follow operating instructions.	4. Keep away from children.	6. Explosive gas hazard.
Refer to General Warnings for more information.		

1642

Figure 1-4 International Safety Symbols on Batteries

SECTION 2 — VEHICLE SPECIFICATIONS

2

VEHICLE SPECIFICATIONS

VEHICLE SPECIFICATIONS – ELECTRIC VEHICLES

SPECIFICATIONS	CARRYALL 500	CARRYALL 700
POWER SOURCE	ELECTRIC	ELECTRIC
Drive motor: Direct drive, 48 volts DC, shunt wound, 3.7 hp	•	•
Transaxle: Double reduction helical gear with 12.3:1 direct drive axle	•	•
Electrical system: 48 volts DC, reduced speed reverse	•	•
Batteries: High capacity, deep cycle, 6-volt	•	•
Charger: Automatic, 48-volt; UL and CSA listed See QuiQ Battery Charger Specifications on page 2-3.	•	•
STEERING/SUSPENSION/BRAKES		
Steering: Self-adjusting rack and pinion	•	•
Suspension: Independent leaf spring with dual hydraulic shocks	•	•
Brakes: Mechanical brake cable system to manually-adjusted drum brakes on all four wheels. Park brake is automatically released. Multi-latch ratchet and pawl.	•	•
BODY/CHASSIS		
Frame/chassis: Twin I-Beam welded aluminum	•	•
Side and rear body: Aluminum	•	•
Front body: ArmorFlex®	•	•
Front body finish: Automotive-grade paint with clear-coat finish	•	•
Tires: 20 x 10 - 10 tubeless, 6-ply rated load range front and rear	•	•
Tires (Turf): 23 x 10.5 - 12 tubeless, 4-ply rated load range front and rear		
Tires (All-Terrain): 22 x 11 - 10 tubeless, 6-ply rated load range front and rear		
DIMENSIONS/WEIGHT		
Overall length: Standard boxbed configuration Add for Heavy-Duty Bumper:	118 in (299.7 cm) 1.8 in (4.5 cm)	139.3 in (358.8 cm) 1.8 in (4.5 cm)
Overall width with mirrors:	50.3 in (127.7 cm) 62.6 in (159.0 cm)	50.3 in (127.7 cm) 62.6 in (159.0 cm)
Overall height: At steering wheel	47.1 in (119.6 cm)	47.1 in (119.6 cm)
Overall height: with canopy	70.7 in (179.5 cm)	70.7 in (179.5 cm)
Overall height: with cab	74.3 in (188.7 cm)	74.3 in (188.7 cm)
Wheelbase	78.1 in (198.3 cm)	99.1 in (251.7 cm)
Ground clearance	5.6 in (14.2 cm)	5.6 in (14.2 cm)
Front wheel tread	36.6 in (92.9 cm)	36.6 in (92.9 cm)
Rear wheel tread	39.5 in (100.3 cm)	39.5 in (100.3 cm)

SPECIFICATIONS	CARRYALL 500	CARRYALL 700
POWER SOURCE	ELECTRIC	ELECTRIC
Weight: Standard electric vehicle (curb weight)	1393 lb (632 kg)	1475 lb (669 kg)
Maximum forward speed	15 to 17 mph (24 to 27 km/h)	15 to 17 mph (24 to 27 km/h)
Outside clearance circle (diameter)	248.5 in (631.1 cm)	340.5 in (864.9 cm)
Turning radius per SAE J 695	119 in (302.2 cm)	162.8 in (413.4 cm)
Intersecting aisle clearance	88.9 in (225.8 cm)	123.9 in (314.7 cm)
Floorboard height	12.5 in (31.7 cm)	12.5 in (31.7 cm)
Load bed height	29.5 in (74.9 cm)	29.5 in (74.9 cm)
Load bed size: Box bed inside dimensions	44.2 x 47.5 x 10.5 in (112.2 x 120.6 x 26.6 cm)	64.5 x 47.5 x 10.5 in (163.8 x 120.6 x 26.6 cm)
Load bed size: Flat bed inside dimensions	46.2 x 48.8 in (117.3 x 123.9 cm)	65.5 x 48.8 in (166.4 x 123.9 cm)
Vehicle rated capacity: Level surface only	1200 lb (544.3 kg)	1500 lb (680.3 kg)
Standard seating capacity	2	2
LIQUID CAPACITIES		
Transaxle	22 fl-oz (0.67 L)	22 fl-oz (0.67 L)
TIRE PRESSURE		
Front and rear	28 to 32 psig (193 to 221 kPa)	28 to 32 psig (193 to 221 kPa)
NOISE AND VIBRATION		
Drive-by noise level to operator Test method: EN 12053:2001	70.3 dBa Uncertainty: ±2 dBa	73 dBa Uncertainty: ±2 dBa
Vibration at driver's seat Test method: EN 13059:2002	0.6 (m/s ²) ² Uncertainty: 0.18 (m/s ²) ²	0.7 (m/s ²) ² Uncertainty: 0.21 (m/s ²) ²

QUIQ BATTERY CHARGER SPECIFICATIONS

QUIQ BATTERY CHARGER SPECIFICATIONS	
AC INPUT	
AC Voltage – range	85 to 265 VAC (acceptable)
AC Voltage – nominal	120 to 230 VAC
Frequency	45 to 65 Hz
AC Power Factor – nominal	>0.99 @ 120 VAC / >0.98 @ 230 VAC
POWER CONSUMPTION	
AC current (amps)	Max: 12 Amps Nominal: 9.5 Amps rms @ 120 VAC 5 Amps rms @ 230 VAC
DC OUTPUT	
DC voltage (VDC) – nominal	48 V
DC voltage (VDC) – maximum	68 V
DC current – maximum	18 Amps
Interlock current – maximum	1 Amp
DIMENSIONS/WEIGHT	
Case – Overall length	11 in (28 cm)
Case – Overall width	9.7 in (24.6 cm)
Case – Overall height	4.3 in (11 cm)
Weight – with standard output cord	< 11 lb (< 5 kg)
MOUNTING CONFIGURATION	
Mounting	Onboard

VEHICLE SPECIFICATIONS – GASOLINE VEHICLES

NOTE: Engine horsepower and torque specifications are provided by the engine manufacturer. Actual horsepower and torque in use may differ and are dependent on environmental conditions as well as maintenance condition of the engine.

SPECIFICATIONS	CARRYALL 500	CARRYALL 700
POWER SOURCE	GASOLINE	GASOLINE
Engine: 4 cycle, OHC, 404 cc, 14.0 Horsepower (10.4 kW) rated engine @ 3600 RPM (per SAE J 1940), single cylinder, air cooled, with splash lubrication system	•	•
Fuel system: Electronic fuel injection (EFI), high-pressure rotary fuel pump with 10 micron fuel filter	•	•
Battery: 12-volt, Top-Post Battery	•	•
Governor: Automatic ground speed sensing, internally geared in transaxle	•	•
Ignition: Digital CDI with electronic RPM limiter	•	•
Transaxle: Precision helical gears, forward/reverse with neutral position (11.47:1 forward; 15.63:1 reverse), with optional limited slip differential	•	•
Electrical system: 12 volt, 525 CCA, 85 minute reserve capacity	•	•
Gasoline Vehicle Electrical Charging System: 23 amps at max. RPM.	•	•
Torque converter: Automatic, variable speed, dry type	•	•
STEERING/SUSPENSION/BRAKES		
Steering: Self-adjusting rack and pinion	•	•
Suspension: Independent leaf spring with dual hydraulic shocks	•	•
Brakes: Mechanical brake cable system to manually-adjusted drum brakes on all four wheels. Park brake is automatically released. Multi-latch ratchet and pawl.	•	•
BODY/CHASSIS		
Frame/chassis: Twin I-Beam welded aluminum	•	•
Side and rear body: Aluminum	•	•
Front body: ArmorFlex®	•	•
Front body finish: Automotive-grade paint with clear-coat finish	•	•
Tires: 20 x 10 - 10 tubeless, 6-ply rated load range front and rear	•	•
Tires (Turf): 23 x 10.5 - 12 tubeless, 4-ply rated load range front and rear		
Tires (All-Terrain): 22 x 11 - 10 tubeless, 6-ply rated load range front and rear		
DIMENSIONS/WEIGHT		
Overall length: Standard boxbed configuration Add for Heavy-Duty Bumper:	118 in (299.7 cm) 1.8 in (4.5 cm)	139.3 in (358.8 cm) 1.8 in (4.5 cm)
Overall width with mirrors:	50.3 in (127.7 cm) 62.6 in (159.0 cm)	50.3 in (127.7 cm) 62.6 in (159.0 cm)
Overall height: at steering wheel	47.1 in (119.6 cm)	47.1 in (119.6 cm)
Overall height: with canopy	70.7 in (179.5 cm)	70.7 in (179.5 cm)
Overall height: with cab	74.3 in (188.7 cm)	74.3 in (188.7 cm)

SPECIFICATIONS	CARRYALL 500	CARRYALL 700
POWER SOURCE	GASOLINE	GASOLINE
Wheelbase	78.1 in (198.3 cm)	99.1 in (251.7 cm)
Ground clearance	5.2 in (13.2 cm)	5.2 in (13.2 cm)
Front wheel tread	36.6 in (92.9 cm)	36.6 in (92.9 cm)
Rear wheel tread	39.5 in (100.3 cm)	39.5 in (100.3 cm)
Weight: Standard gasoline vehicle (curb weight)	907 lb (411 kg)	993 lb (450 kg)
Maximum forward speed	15 to 17 mph (24 to 27 km/h)	15 to 17 mph (24 to 27 km/h)
Outside clearance circle (diameter)	248.5 in (631.1 cm)	340.5 in (864.9 cm)
Turning radius per SAE J 695	119 in (302.2 cm)	162.8 in (413.4 cm)
Intersecting aisle clearance	88.9 in (225.8 cm)	123.9 in (314.7 cm)
Floorboard height	12.5 in (31.7 cm)	12.5 in (31.7 cm)
Load bed height	29.5 in (74.9 cm)	29.5 in (74.9 cm)
Load bed size: Box bed inside dimensions	44.2 x 47.5 x 10.5 in (112.2 x 120.6 x 26.6 cm)	64.5 x 47.5 x 10.5 in (163.8 x 120.6 x 26.6 cm)
Load bed size: Flat bed inside dimensions	46.2 x 48.8 in (117.3 x 123.9 cm)	65.5 x 48.8 in (166.4 x 123.9 cm)
Vehicle rated capacity: Level surface only	1200 lb (544.3 kg)	1500 lb (680.3 kg)
Standard seating capacity: (persons)	2	2
LIQUID CAPACITIES		
Engine crankcase	40.5 fl-oz (1.2 L)	40.5 fl-oz (1.2 L)
Transaxle	67.6 fl-oz (2 L)	67.6 fl-oz (2 L)
Fuel tank	4.6 gallons (17.4 L)	4.6 gallons (17.4 L)
TIRE PRESSURE		
Front and rear	28 to 32 psig (193 to 221 kPa)	28 to 32 psig (193 to 221 kPa)
NOISE AND VIBRATION		
Drive-by noise level to operator Test method: EN 12053:2001	77.2 dBa Uncertainty: ±2 dBa	77.2 dBa Uncertainty: ±2 dBa
Vibration at driver's seat Test method: EN 13059:2002	0.7 (m/s ²) ² Uncertainty: 0.21 (m/s ²) ²	0.8 (m/s ²) ² Uncertainty: 0.22 (m/s ²) ²

Pagination Page

⚠ DANGER

- See General Warnings on page 1-1.

⚠ WARNING

- See General Warnings on page 1-1.

Important features unique to the different models covered in this manual are highlighted. Club Car, LLC recommends the owner/operator read and understand this manual and pay special attention to features specific to their vehicle(s).

Refer to the owner's manual provided with the vehicle for information on the following topics:

- Controls and Indicators
- Pre-Operation and Daily Safety Checklist
- Driving Instructions
- Bed Latch
- Prop Rod
- Loading and Unloading
- Towing with a Vehicle
- Transporting on a Trailer
- Subsequent Owner Registration
- Warranties

MODEL IDENTIFICATION

The serial number of each vehicle is printed on a bar code decal mounted below the center dash panel (Example: CC5819-123456) (**Figure 3-1**).

The two letters (1) at the beginning of the serial number indicate the vehicle model. The following four digits (2) indicate the model year and production week during which the vehicle was built. The six digits (3) following the hyphen represent the unique sequential number assigned to each vehicle built within a given model year. **See following NOTE.**

NOTE: Have the vehicle serial number available when ordering parts or making inquiries.

Build Code: The build code (4) is a five-digit number that appears on the vehicle serial number decal. The build code exists to enable the user to identify the correct owner's manual for a vehicle. This owner's manual is valid for the build code range indicated on the back cover of this owner's manual.

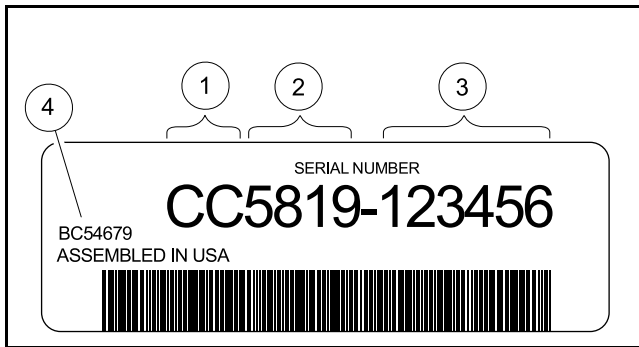

2843

Figure 3-1 Serial Number Decal

STORAGE – ELECTRIC VEHICLES

See General Warnings on page 1-1.

⚠ WARNING

- Turn the key switch to the OFF position, remove the key, and leave the Forward/Reverse handle or switch in the NEUTRAL position during storage. This is to prevent unintentionally starting the vehicle or a fire hazard. Place Run/Tow switch in the TOW position.
- Only trained technicians should service or repair the vehicle or battery charger. Anyone doing even simple repairs or service should have knowledge and experience in electrical and mechanical repair. The appropriate instructions must be used when performing maintenance, service, or accessory installation.
- Do not attempt to charge frozen batteries or batteries with bulged cases. Discard the battery. Frozen batteries can explode.

⚠ CAUTION

- Batteries in a low state of charge will freeze at low temperatures.
- To avoid exposing electrical components to moisture and subsequent damage, do not use any type or pressure washing or steam cleaning equipment to wash the vehicle.

PREPARING THE ELECTRIC VEHICLE FOR EXTENDED STORAGE

Check Battery Water Levels Two Weeks Prior to Storage

Check water levels at least two weeks prior to winter storage to ensure proper mixing of water and electrolyte. Note that it takes approximately five charge cycles with a minimum of 10 amp hours removed after each charge to properly mix the water with electrolyte. Do NOT water batteries immediately prior to storage because this will not provide sufficient charge time to mix the water with the electrolyte. Freezing can occur when batteries are stored in this condition.

1. Check the water levels in each battery cell. If water is required, fill the cells to cover the plates, charge the batteries, and then use distilled water to fill each cell to the correct level. Electrolyte level should be from 1/2 inch (13 mm) above plates to 1/4 inch (6 mm) below the level indicator (**Figure 14-3**).

Immediately Prior to Storage, Perform the Following Steps

1. Unload the vehicle so that tires are supporting only the weight of the vehicle.
2. Turn the key switch to the OFF position, remove the key, and leave the Forward/Reverse switch in the NEUTRAL position during storage.
3. If so installed, turn off all accessories, including GPS units, fans, etc.
4. Place the Run/Tow switch in the TOW position.

NOTE: All functions of the dash-mounted charger information light are disabled when the Run/Tow switch is in the TOW position.

5. Batteries should be clean and free of corrosion. Wash tops and terminals of batteries with a solution of baking soda and water; use 1 cup (237 mL) baking soda per 1 gallon (3.8 L) of water. Rinse solution off batteries. Do not allow this solution to enter the batteries. Let the terminals dry and then coat them with Battery Terminal Protector Spray.
6. Tighten all battery cable connections to 110 in·lb (12.4 N·m).
7. Store vehicle in a cool, dry place. This will minimize battery self-discharge.
8. Adjust tires to recommended tire pressure. **See Vehicle Specifications – Electric Vehicles on page 2-1.**
9. Perform semiannual periodic lubrication. **See Periodic Lubrication Schedules on page 10-7.**
10. Thoroughly clean front body, rear body, seats, battery compartment, and underside of vehicle.
11. Do not engage the park brake. Chock the wheels to prevent the vehicle from rolling.

NOTE: It is recommended that the vehicles be plugged in and the electrolyte level maintained throughout the storage period. If any of the following conditions exist, however, then disconnect the batteries for storage: 1) The charger cannot remain plugged in, 2) AC power will not be available during extended storage, or 3) Electrolyte levels will not be maintained. To disconnect batteries for storage, go to step 13.

12. To keep batteries fully charged during storage:
 - 12.1. Plug the battery charger into the car. Leave battery chargers plugged in during storage. The charger will automatically activate when necessary.
 - 12.2. Check the electrolyte level and charger function monthly to ensure that proper operation is maintained.

CAUTION

- **Be sure to check the batteries and charger monthly to maintain correct battery water level and to ensure the charger is operating correctly during storage.**
13. If disconnecting the batteries for storage, disconnect B negative (-) battery cable and secure it in a way that ensures the cable will not come into contact with battery terminal.

RETURNING THE STORED ELECTRIC VEHICLE TO SERVICE

1. If necessary, connect batteries. **See Connecting the Batteries – Electric Vehicles on page 1-4.**
2. Fully charge batteries.

⚠ WARNING

- **Do not attempt to charge frozen batteries or batteries with bulged cases. Discard the battery. Frozen batteries can explode.**
3. Adjust tires to recommended tire pressure. **See Vehicle Specifications – Electric Vehicles on page 2-1.**
 4. Perform the Pre-Operation and Daily Safety Checklist on page 10-1 and the Performance Inspection on page 10-1.

STORAGE – GASOLINE VEHICLES

See General Warnings on page 1-1.

⚠ DANGER

- Do not attempt to drain fuel when the engine is hot or while it is running.
- Be sure to clean up any spilled gasoline before operating the vehicle.
- Store fuel in an approved fuel container only. Store in a well-ventilated area away from sparks, open flames, heaters, or heat sources.
- Keep fuel out of the reach of children.
- Do not siphon fuel from the vehicle.

⚠ WARNING

- Only trained technicians should service or repair the vehicle or battery charger. Anyone doing even simple repairs or service should have knowledge and experience in electrical and mechanical repair. The appropriate instructions must be used when performing maintenance, service, or accessory installation.
- Turn the key switch to the OFF position, remove the key, and leave the Forward/Reverse handle in the NEUTRAL position during storage. This is to prevent unintentionally starting the vehicle or a fire hazard.
- Do not attempt to charge frozen batteries or batteries with bulged cases. Discard the battery. Frozen batteries can explode.

⚠ CAUTION

- Batteries in a low state of charge will freeze at low temperatures.

PREPARING THE GASOLINE VEHICLE FOR EXTENDED STORAGE

1. Unload the vehicle so that tires are supporting only the weight of the vehicle.
2. Store vehicle in a cool, dry place. This will minimize battery self-discharge. If the battery appears to be weak, have it charged by a trained technician. Use an automotive-type 12-volt battery charger rated at 10 amps or less.
3. Seal the fuel tank.
 - 3.1. Fill fuel tank, and, following manufacturer's directions, add a commercially available fuel stabilizer (such as Sta-Bil®).
 - 3.2. Disconnect fuel vent line from fuel tank vent nipple.
 - 3.3. Plug the fuel tank vent nipple so that it is air tight. We recommend using a slip-on vinyl cap.

NOTE: *It is not necessary to drain the fuel line.*

4. Disconnect battery and spark plug wire. **See Disconnecting the Battery-Gasoline Vehicles on page 1-5.**
5. Batteries should be clean and free of corrosion. Wash tops and terminals of batteries with a solution of baking soda and water: use 1 cup (237 mL) baking soda per 1 gallon (3.8 L) of water. Rinse solution off batteries. Do

not allow this solution to enter the batteries. Let the terminals dry and then coat them with Battery Terminal Protector Spray.

6. To protect the engine, remove spark plug and pour 0.5 fl-oz (14.2 mL) of SAE 10 weight oil into the engine through the spark plug hole. Rotate engine crankshaft by hand several times and then install the spark plug and tighten it to 20 ft·lb (27 N·m).
7. Adjust tires to recommended tire pressure. **See Vehicle Specifications on page 2-1.**
8. Perform semiannual periodic lubrication. **See Periodic Lubrication Schedules on page 10-7.**
9. Thoroughly clean front body, rear body, seats, cargo bed, engine compartment, and underside of vehicle.
10. Do not engage the park brake. Chock the wheels to prevent the vehicle from rolling.

RETURNING THE STORED GASOLINE VEHICLE TO SERVICE

1. Restore fuel system to operation.
 - 1.1. Remove plug from the fuel tank vent (**Figure 23-16, Page 23-25**).
 - 1.2. Connect vent tube to fuel tank vent.
2. Connect battery and spark plug wire. **See Connecting the Battery-Gasoline Vehicles on page 1-5.**
3. Place the Forward/Reverse handle in the NEUTRAL position and the neutral lockout switch in the MAINTENANCE position. Crank the engine until the engine starts. Turn the engine off and return the neutral lockout switch to the OPERATE position. **See following NOTE.**

NOTE: Due to the oil added to the engine in preparation for storage, engine may smoke excessively for a short time when it is run for the first time after storage.

4. Adjust tires to recommended tire pressure. **See Vehicle Specifications – Gasoline Vehicles on page 2-4.**
5. Perform the Pre-Operation and Daily Safety Checklist on page 10-1 and the Performance Inspection on page 10-1.

Pagination Page

⚠ DANGER

- See General Warnings on page 1-1.

⚠ WARNING

- See General Warnings on page 1-1.

CLEANING THE VEHICLE

See General Warnings on page 1-1.

CAUTION

- Do not use detergents or cleaning solvents that contain ammonia, aromatic solvents, or alkali materials on body panels or seats.
- Do not allow battery acid to drip on body panels. Battery acid will cause permanent damage. Wash spilled battery acid from body panels immediately.

These vehicles are equipped with painted TPO front bodies and aluminum only rear bodies with black polypropylene rear fender and tailskirt. The cargo beds are steel with aluminum sheet and Rhino Lining®.

The manufacturer does not recommend any type of pressure washing or steam cleaning. Such a process will expose electrical components to moisture. Moisture entering electrical components can result in water damage and subsequent component failure. Normal residential water pressure is adequate for exterior cleaning.

For regular cleaning, use commercially available automotive cleaning solutions with a sponge or soft cloth. The painted finish is the same paint used in automotive applications. Automotive cleaning/polishing products are available at automotive specialty and hardware stores.

Use non-abrasive wax products. Battery acid, fertilizers, tars, asphalt, creosote, paint, or chewing gum should be removed immediately to prevent possible stains.

SEAT CLEANING

Clean seats regularly using the following guidelines:

Light Soiling – A solution of 10% liquid dish soap and warm water applied with a soft, damp cloth is recommended. A soft bristle brush may be used if necessary. Wipe off any residue with a water dampened cloth. **See following NOTE.**

NOTE: *Dispose of waste water properly.*

Difficult Stains – Dampen a soft, white cloth with a solution of 10% household bleach (sodium hypochlorite) and 90% water. Rub gently to remove stain, then rinse with a water dampened cloth to remove bleach concentration.

More Difficult Stains – Perform previous procedure using full-strength bleach, or allow bleach to puddle on affected area for approximately 30 minutes. Rinse with a water dampened cloth to remove any remaining bleach concentration. **See following CAUTION.**

CAUTION

- To prevent damage to the vehicle when removing difficult stains or heavy soiling, remove the seat from the vehicle first.

FRONT BODY REPAIR

See General Warnings on page 1-1.

LIGHT SCRATCHES

1. Clean entire area to be repaired with clean, clear water.
2. Using 1200 grit sandpaper, water-sand entire area of scratch until original scratch is no longer visible, either with finishing sander or wet sanding block. Be sure that sandpaper is centered on sanding pad. Continue to flush with water while sanding, to increase sandpaper life and keep the sanded surface cool. Wipe repaired area dry and visually inspect to be sure that the original scratch has completely disappeared.
3. Repeat step 2 using 1500 grit sandpaper until all 1200 grit scratches are removed paying close attention to edges.
4. Install a wool cutting pad (3M #5711 or equivalent) on buffer and spread approx 1/2 tsp. (2mL) of compound (3M #05955 or equivalent). Buff slowly and steadily over small area so as not to heat surface as this may cause warping or melting of plastic. Buff sanded area until all sanding scratches have disappeared. Use as much buffing compound as necessary to achieve this step. If at any time original scratches can be seen, repeat steps 2 and 3 as needed. When all 1500 grit scratches have disappeared, there will be a dull luster over entire area.
5. Install a foam polishing pad (3M #5725 or equivalent) on buffer and repeat step 4 using approx 1/2 tsp. (2 mL) buffing compound (3M #5933 or equivalent). Buff compound off until scratches have disappeared. It may be necessary to apply additional compound to achieve this. The result will be an almost-finished product with a very high luster and very few buffer swirls.
6. Using a clean foam polishing pad (3M #5725 or equivalent) and finish glaze (3M #05937 or equivalent), apply a slightly smaller amount of material than in steps 4 and 5 and buff to desired gloss.
7. Wipe clean with soft, clean cloth. Any dirt on cloth can mar surface.

ABRASIONS AND HAZE

Abrasions and haze can be greatly minimized by performing steps 5 through 7 above.

LARGE SCRATCHES AND ABRASIONS

Touch-up is not recommended. Replace the entire body part or have it repaired by a professional paint and body repair shop with experience repairing bodies.

TOUCH-UP PAINT COLOR CHART

COLOR	CC P/N
White	105117701
Classic Blue	105117702
Dark Green	105117703
Red	105117704

TABLE CONTINUED ON NEXT PAGE

COLOR	CC P/N
Dark Gray	105117705
Black	105117706
Tan	105117707
Bright Blue	105117708
TITN Silver	105117709
Light Gray	105117710

FRONT BODY

See General Warnings on page 1-1.

HEAVY DUTY BUMPER REMOVAL

1. Disconnect the batteries. **See Disconnecting the Batteries – Electric Vehicles, Section 1, Page 1-4.**
See Disconnecting the Battery-Gasoline Vehicles on page 1-5.
2. Loosen and remove screws (1), washers (3), and locknuts (2) that attach heavy duty (HD) bumper mounting bracket (4) to HD bumper weldment (5) (**Figure 4-1, Page 4-4**).
3. Remove plastic bumper (13).
4. Remove HD bumper and weldment.

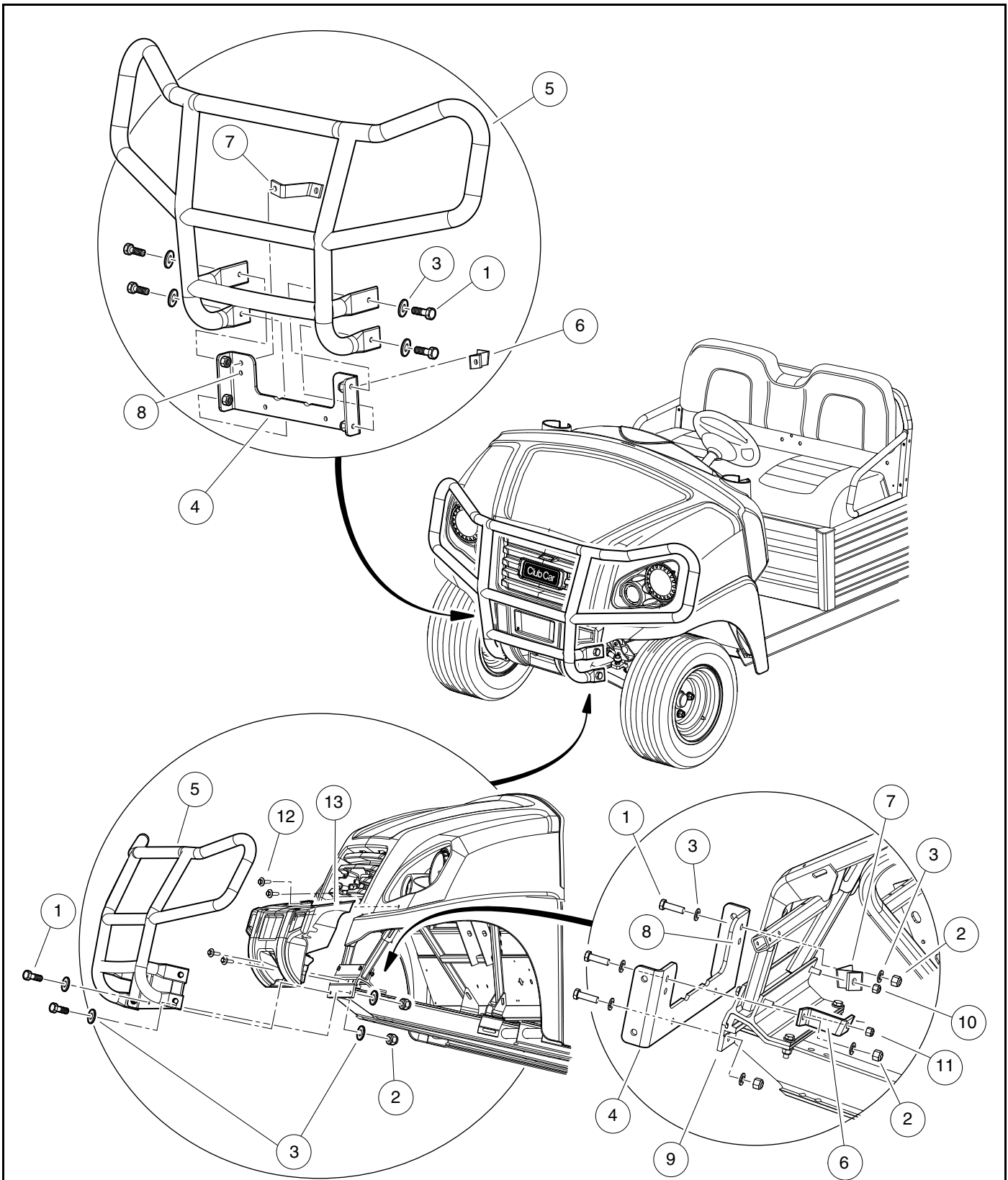

2986

Figure 4-1 Heavy Duty Bumper

HEAVY DUTY BUMPER INSTALLATION

1. Position brush guard mounting bracket (4) onto brush guard weldment (5). Align holes and secure with four screws (1), eight washers (3), and four locknuts (2) (**Figure 4-1, Page 4-4**).
2. Attach plastic bumper (13).
3. Use the existing fastener holes in the mounting bracket and vehicle structure as an alignment guide.
4. Secure the brush guard mounting bracket to the vehicle using two screws (1), four washers (3), and locknuts (2).
5. Tighten all attaching hardware to 15 ft·lb (20.3 N·m).
6. Connect the batteries. **See Connecting the Batteries – Electric Vehicles, Section 1, Page 1-4.**
See Connecting the Battery-Gasoline Vehicles on page 1-5.

COWL REMOVAL

1. Park vehicle and chock tires.
2. Disconnect the batteries. **See Disconnecting the Batteries – Electric Vehicles, Section 1, Page 1-4.**
See Disconnecting the Battery-Gasoline Vehicles on page 1-5.
3. The cowl is secured by tabs located behind the front fenders (2), and under the lip of the dash (1) (**Figure 4-2, Page 4-6**).
4. Push down and rearward on front fenders to unsnap cowl in two locations.
5. Slide cowl forward until free, then lift out cowl.

COWL INSTALLATION

1. Slide bottom edges of cowl into grooves in front fenders.
2. Ensure the three tabs on cowl install under lip of dash (1) (**Figure 4-2, Page 4-6**).
3. Ensure sides of cowl (3) assemble between the two ribs on side of dash.
4. Ensure center tab on cowl assembles beneath the rib in the grille.
5. With fenders disengaged from the front bumper, press down on front fenders, line up cowl tabs and fully engage snap tabs.
6. Ensure front corners of cowl are engaged with front fender (2).
7. Engage the front fenders to the body clips under the front bumper.

NOTE: Ensure that cowl is fully engaged to prevent dislodging during use.

8. Connect the batteries. **See Connecting the Batteries – Electric Vehicles, Section 1, Page 1-4.**
See Connecting the Battery-Gasoline Vehicles on page 1-5.
9. Remove tire chocks.

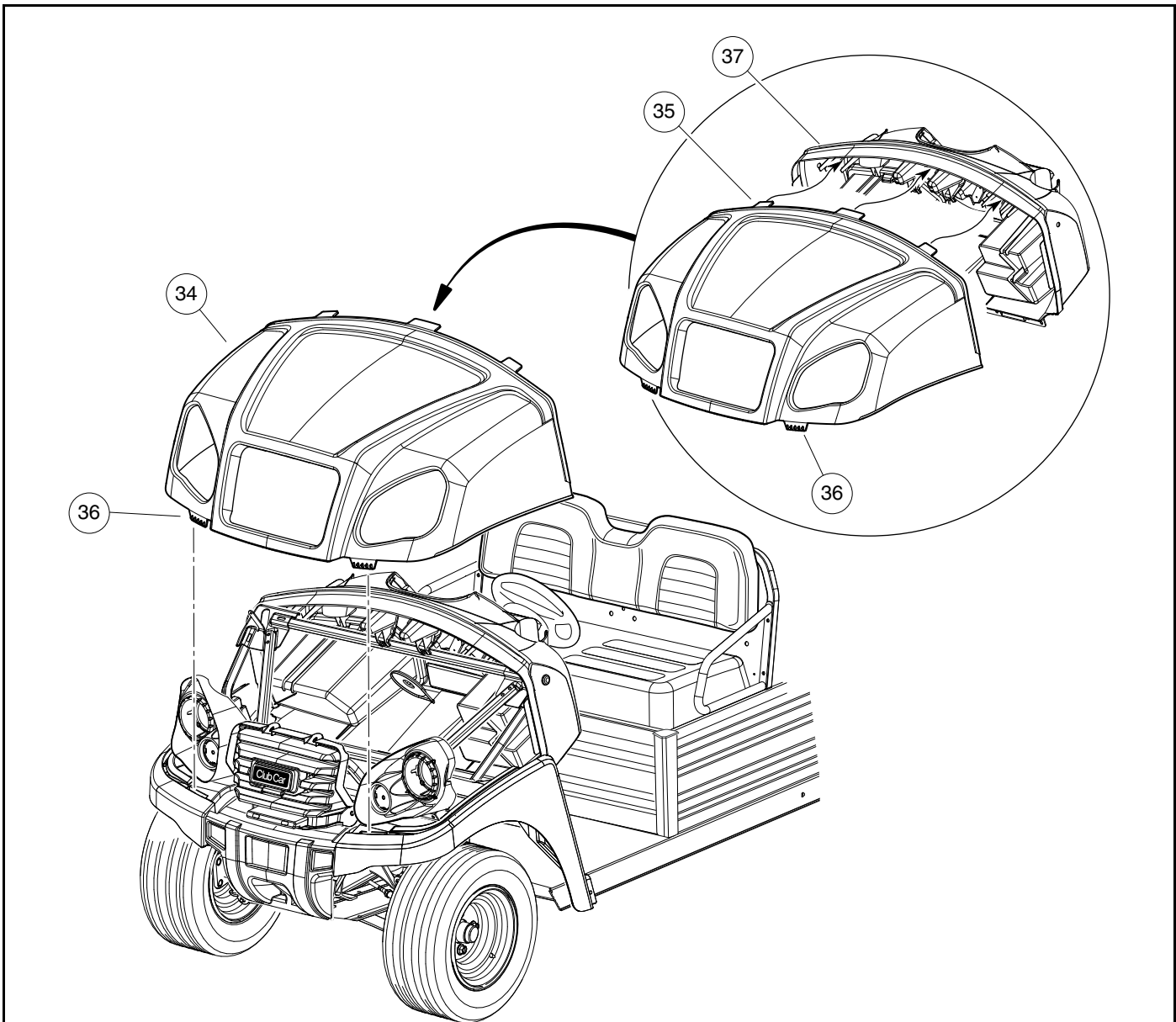

2846

Figure 4-2 Front Cowl

GRILLE REMOVAL

1. Park vehicle and chock the tires.
2. Disconnect the batteries. **See Disconnecting the Batteries – Electric Vehicles, Section 1, Page 1-4. See Disconnecting the Battery-Gasoline Vehicles on page 1-5.**
3. Remove HD bumper (if equipped). **See Heavy Duty Bumper Removal, Section 4, Page 4-3.**
4. Remove cowl. **See Cowl Removal on page 4-5.**
5. Loosen and remove the two M6 self-tapping fasteners (1) at the top of grille (7). **(Figure 4-3, Page 4-8).**
6. Loosen and remove the two lower left and right side bolts (1 and 7) that attach the grille and plastic bumper (6).
7. Remove charger receptacle (if equipped) by removing the three screws that attach the receptacle or disconnect connector (quick connect).

GRILLE INSTALLATION

1. Connect the charger receptacle or connector (quick connect).
2. Install, but do not tighten upper M6 screws. (Do not tighten screws until plastic bumper is installed).
3. Lower grille holes are shared with the front bumper, ensure lower bumper screws are attached first then install grille.
4. Line up upper and lower bolt holes.
5. Install and tighten upper bolts, then lower right and left side bolts. Tighten to 44 in·lb (5 N·m).
6. Connect the batteries. **See Connecting the Batteries – Electric Vehicles, Section 1, Page 1-4.**
See Connecting the Battery-Gasoline Vehicles on page 1-5.

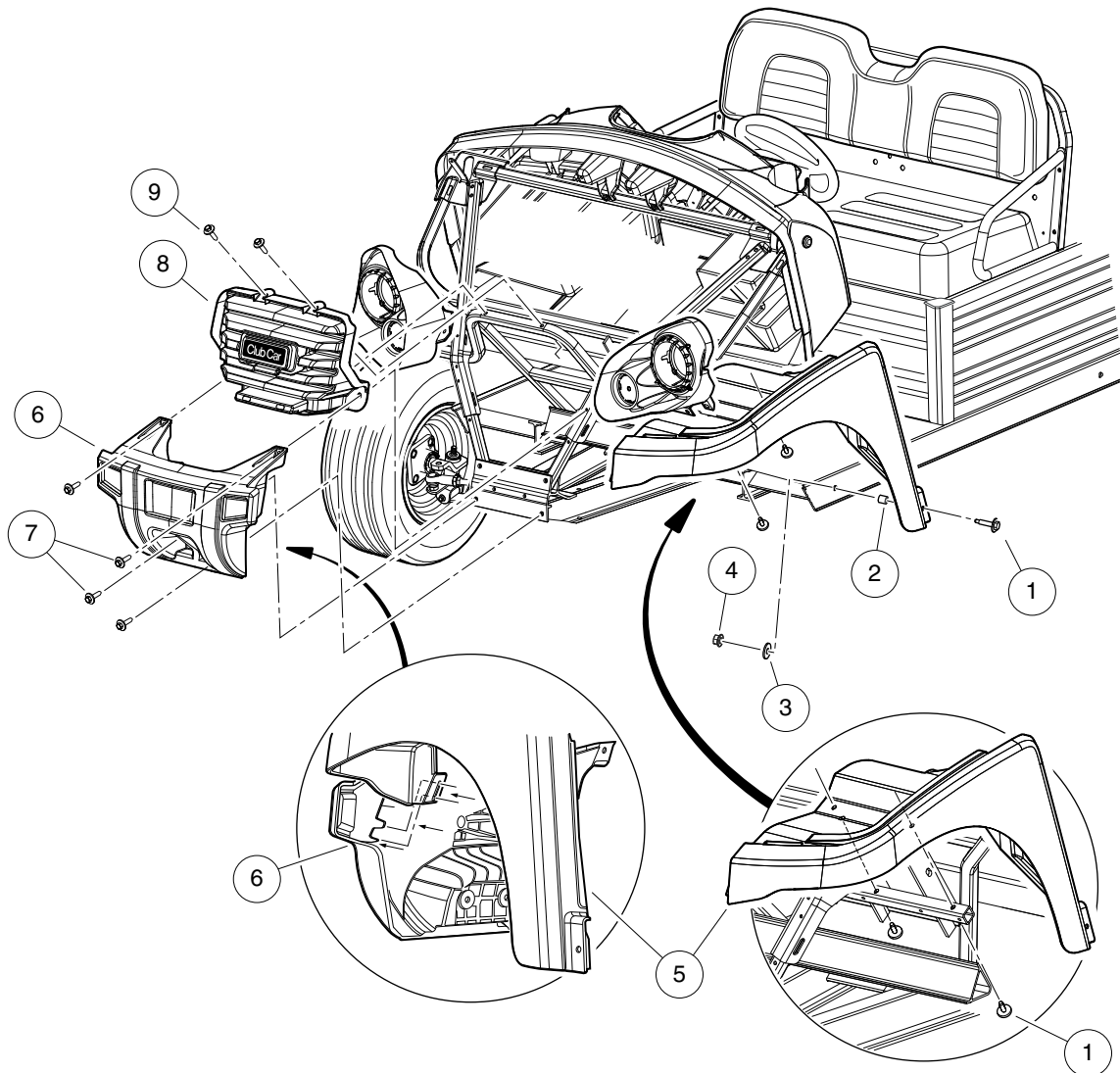

Figure 4-3 Front Grille, Bumper, and Side Fenders

FRONT BUMPER AND SIDE FENDER REMOVAL

1. Park the vehicle, chock tires.
2. Disconnect the batteries. **See Disconnecting the Batteries – Electric Vehicles, Section 1, Page 1-4.**
See Disconnecting the Battery-Gasoline Vehicles on page 1-5.
3. Remove HD bumper, (if equipped). **See Heavy Duty Bumper Removal on page 4-3.**
4. Remove cowl. **See Front Cowl on page 4-6.**
5. Remove the grille. **See Grille Removal on page 4-6.**
6. Loosen and remove the two upper and lower bolts (7) that attach the bumper to the vehicle frame. Push down and rearward on front fenders near the bumper (**Figure 4-3, Page 4-8**).
7. Remove front bumper (6).
8. Loosen and remove the inner screws, nuts, and spacers (1, 2, 3, and 4) that attach the side fender to the frame (repeat procedure on opposite side).
9. Unsnap body clips and remove side fenders (5).

FRONT BUMPER AND SIDE FENDER INSTALLATION

1. Install side fenders (5) by snapping in body clips.
2. Install inner screws, nuts, and spacers (1, 2, 3, and 4) that attach the side fender to the frame.
3. Install front bumper (6).
4. Install the two upper and lower bolts (7) that attach the bumper to the vehicle frame. Push down and rearward on front fenders near the bumper to install.
5. Install the grille. **See Grille Installation, Section 4, Page 4-7.**
6. Install the front cowl. **See Cowl Installation, Section 4, Page 4-5.**
7. Install HD bumper (if equipped). **See Heavy Duty Bumper Installation, Section 4, Page 4-5.**
8. Connect the batteries. **See Connecting the Batteries – Electric Vehicles, Section 1, Page 1-4.**
See Connecting the Battery-Gasoline Vehicles on page 1-5.
9. Remove tire chocks.

INSTRUMENT PANEL REMOVAL

1. Disconnect the batteries. **See Disconnecting the Batteries – Electric Vehicles, Section 1, Page 1-4. See Disconnecting the Battery-Gasoline Vehicles on page 1-5.**
2. Remove front cowl. **See Cowl Removal, Section 4, Page 4-5.**
3. From the inside of the dash, press upper snap tabs (1) of the instrument panel inward to release from dash.
4. Then push the instrument panel near the bottom (2) to pop out the lower body clips (be careful not to pry the lower clips off).
5. Pull instrument panel out from the dash panel (2).

INSTRUMENT PANEL INSTALLATION

1. Place upper tab of instrument panel into slot (1).
2. Snap panel into dash while pushing in on the driver and passenger side tabs and sliding the top portion of the panel into place.
3. Snap lower body clips in at each lower corner.
4. Connect the batteries. **See Connecting the Batteries – Electric Vehicles, Section 1, Page 1-4. See Connecting the Battery-Gasoline Vehicles on page 1-5.**

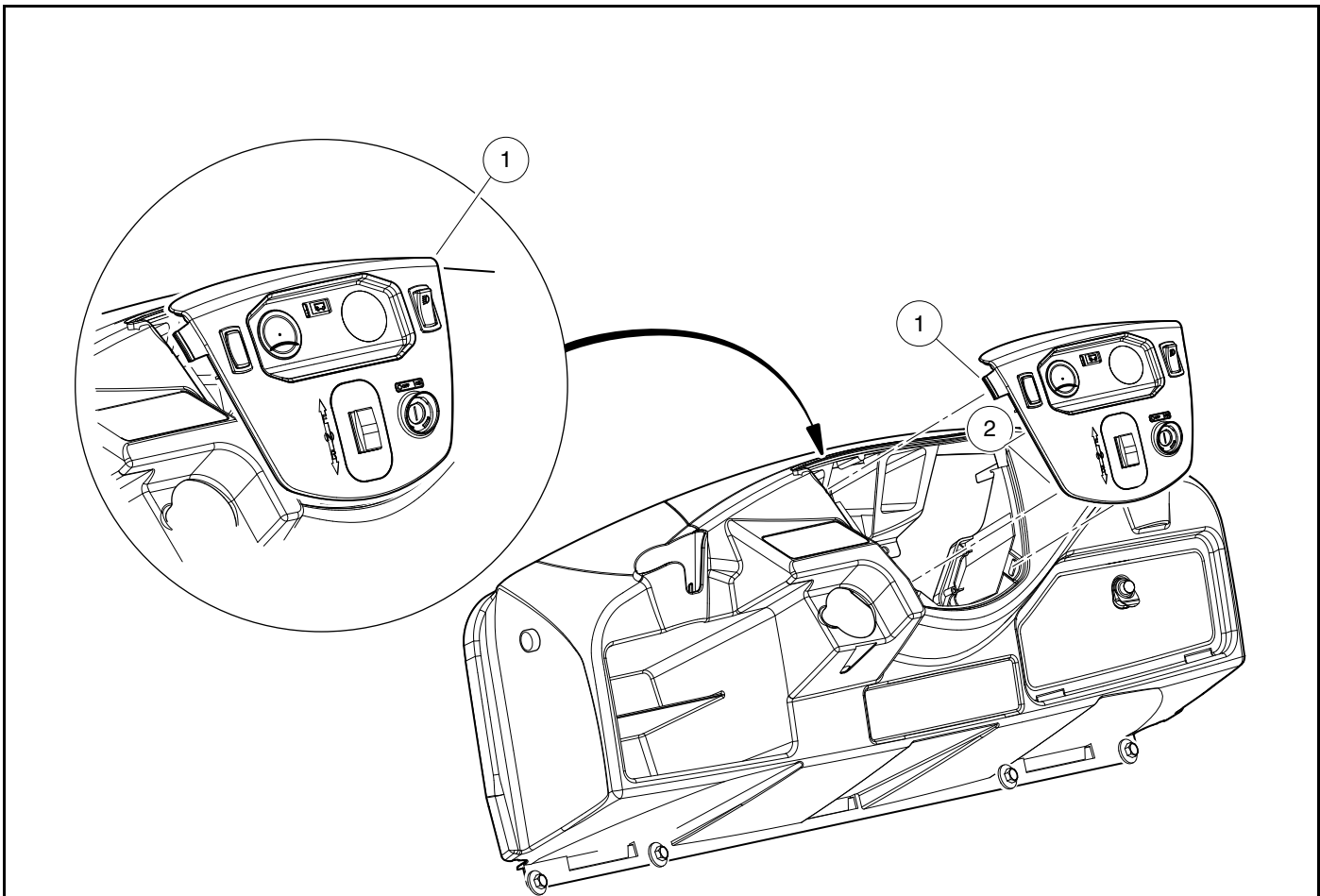

2946

Figure 4-4 Instrument Panel

DASH REMOVAL

1. Disconnect the batteries. **See Disconnecting the Batteries – Electric Vehicles, Section 1, Page 1-4. See Disconnecting the Battery-Gasoline Vehicles on page 1-5.**
2. Remove cowl. **See Cowl Removal on page 4-5.**
3. Remove steering wheel. **See Steering Wheel Removal, Section 7, Page 7-1.**
4. Disconnect instrument panel wiring.
5. Remove the bolts, and washers (5, 6, 7, 8, and 9) from the top, sides and bottom of the dash (10). **(Figure 4-5, Page 4-12).**
6. Remove dash assembly.

DASH INSTALLATION

1. Install dash assembly.
2. Install the bolts, and washers (5, 6, 7, 8, and 9) to the top, sides and bottom of dash (10). **(Figure 4-5, Page 4-12)**
3. Connect instrument panel wiring.
4. Install steering wheel. **See Steering Wheel Installation, Section 7, Page 7-2.**
5. Install cowl. **See Cowl Installation, Section 4, Page 4-5.**
6. Connect the batteries. **See Connecting the Batteries – Electric Vehicles, Section 1, Page 1-4. See Connecting the Battery-Gasoline Vehicles on page 1-5.**

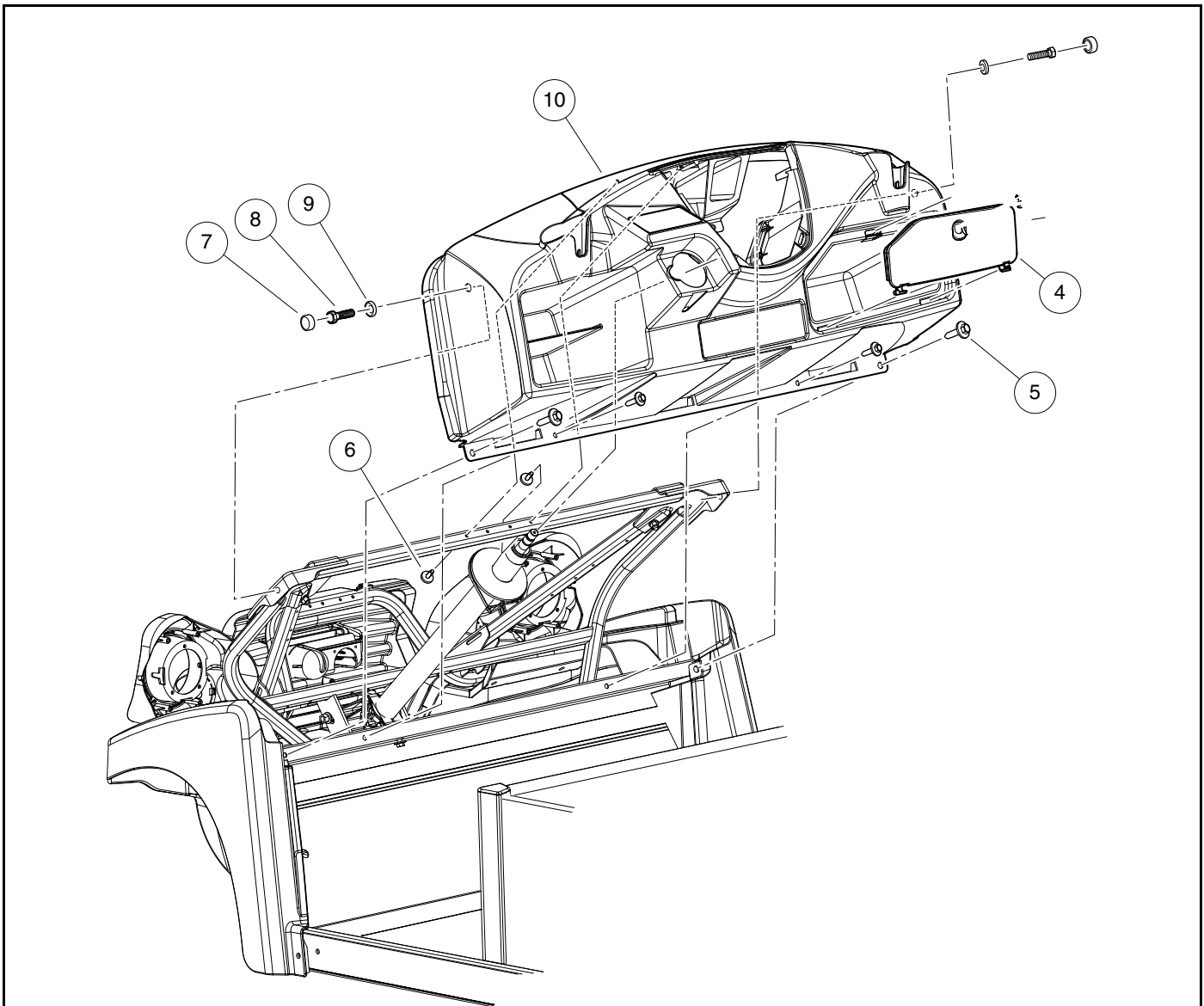

2863

Figure 4-5 Dash Assembly

TILT BED

See General Warnings on page 1-1.

TILT BED REMOVAL

NOTE: This procedure requires two people.

WARNING

- **Remove all cargo before raising the bed or servicing the vehicle. If the vehicle is equipped with a prop rod, ensure that it is securely engaged while bed is raised. Do not close bed until all persons are clear of cargo bed area. Keep hands clear of all crush areas. Do not drop cargo bed; lower gently and keep entire body clear. Failure to heed this warning could result in severe personal injury or death.**
1. Raise bed and secure prop rod (9) in prop rod track (2). Hold bed securely in an upright position. Remove cotter pin (11) and flat washer (17) from top end of prop rod where prop rod attaches to bed. Remove prop rod (9) from bed and place prop rod between prop rod track (2) and rear body panel. Lower bed onto vehicle frame (**Figure 4-6, Page 4-14**).
 2. Remove two lock nuts (8) from left and right hinge assemblies (C).
 3. Apply slight upward pressure (by hand) on the rear of the bed to relieve pressure on the hinges, and remove the hinge bolts (7) from the hinge assemblies.
 4. Raise rear edge of bed approximately 6 inches (15.2 cm) and pull bed assembly toward rear of vehicle approximately 3 inches (7.6 cm) to release bed latch assembly (A) from latch plate (B).
 5. Lift bed from vehicle.

TILT BED INSTALLATION

NOTE: This procedure requires two people.

Lubricate the hinge bolts (7) with light motor oil prior to assembly.

1. Place bed on vehicle. Hold bed at a slight angle (front of bed lower than rear of bed) to vehicle and push front edge of bed onto vehicle frame engaging bed latch assembly (A) with latch plates (B).
2. Install bolt (7) into each hinge assembly.
3. Install a nylon lock nut (8) on each bolt (7) and tighten to 15 ft·lb (21 N·m).
4. Lift bed and insert the prop rod (9) in bed mounting hole. Install a 3/8-inch flat washer (17) and a new cotter pin (11) on prop rod.

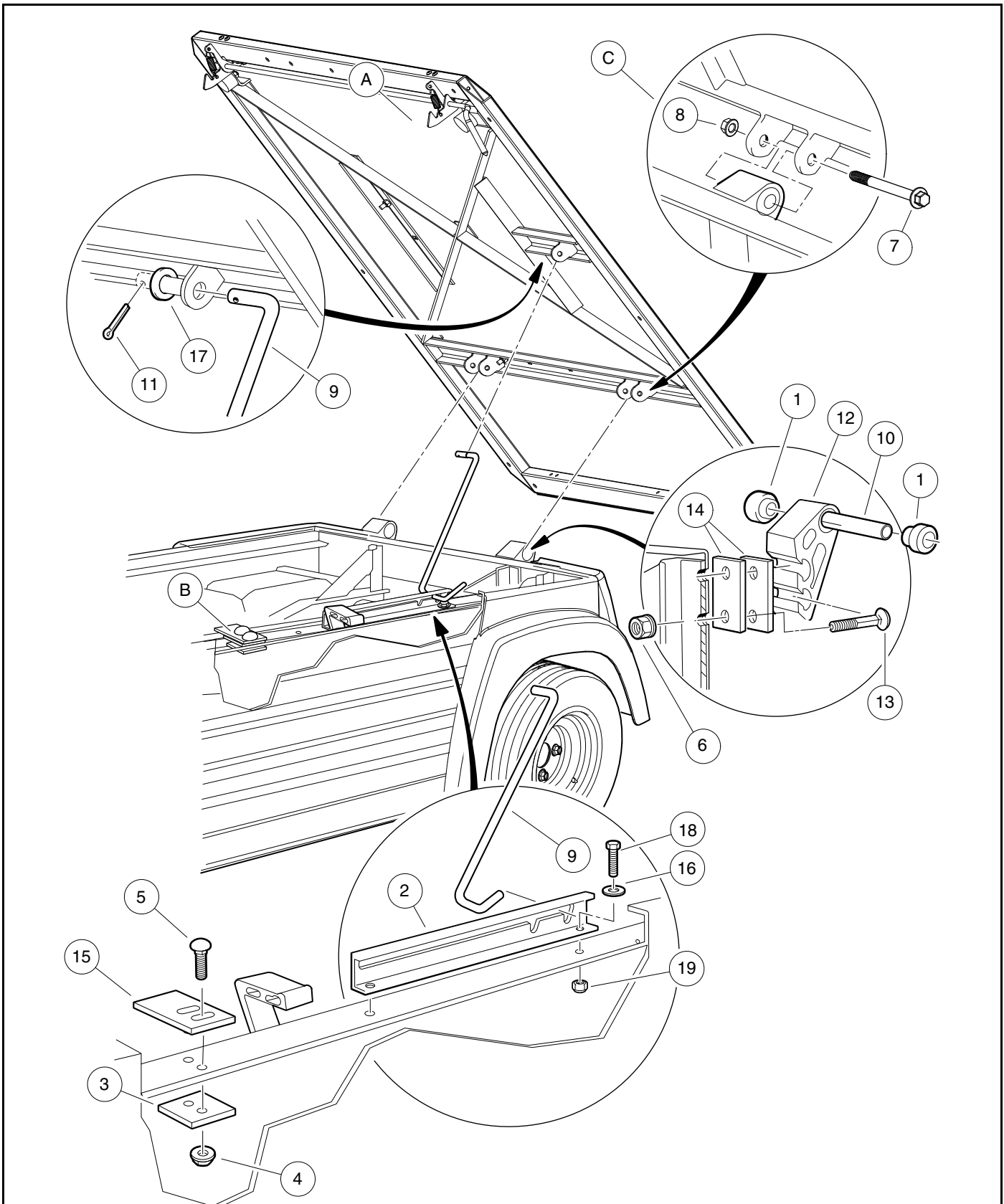

2980

Figure 4-6 Tilt Bed Mounting

BED LATCH ASSEMBLY REMOVAL

NOTE: This procedure requires the aid of an assistant.

1. Park the vehicle and chock the tires.
2. Disconnect the batteries. **See Disconnecting the Batteries – Electric Vehicles, Section 1, Page 1-4. See Disconnecting the Battery-Gasoline Vehicles on page 1-5.**
3. Raise bed and secure prop rod (9) in prop rod track (2) (**Figure 4-6, Page 4-14**). **See following WARNING.**

⚠ WARNING

- Remove all cargo before raising the bed or servicing the vehicle. If the vehicle is equipped with a prop rod, ensure that it is securely engaged while bed is raised. Do not close bed until all persons are clear of cargo bed area. Keep hands clear of all crush areas. Do not drop cargo bed; lower gently and keep entire body clear. Failure to heed this warning could result in severe personal injury or death.
4. Remove the four bolts (12) and lock nuts (7) that secure the bed latch (6) to the underside of the bed (**Figure 4-7, Page 4-16**).
 5. Remove the bed latch (6) and springs (5).

BED LATCH ASSEMBLY INSTALLATION

1. Install bed latch (6) and springs (5).

NOTE: Latch assembly needs to sit open exactly as shown (**Figure 4-7, Page 4-16**).

2. Install the four bolts (12) and lock nuts (7) that secure the bed latch (6) to the underside of the bed. Tighten to 70 to 80 in·lb (8 to 9 N·m).
3. Connect the batteries. **See Connecting the Batteries – Electric Vehicles, Section 1, Page 1-4. See Connecting the Battery-Gasoline Vehicles on page 1-5.**
4. Remove tire chocks.

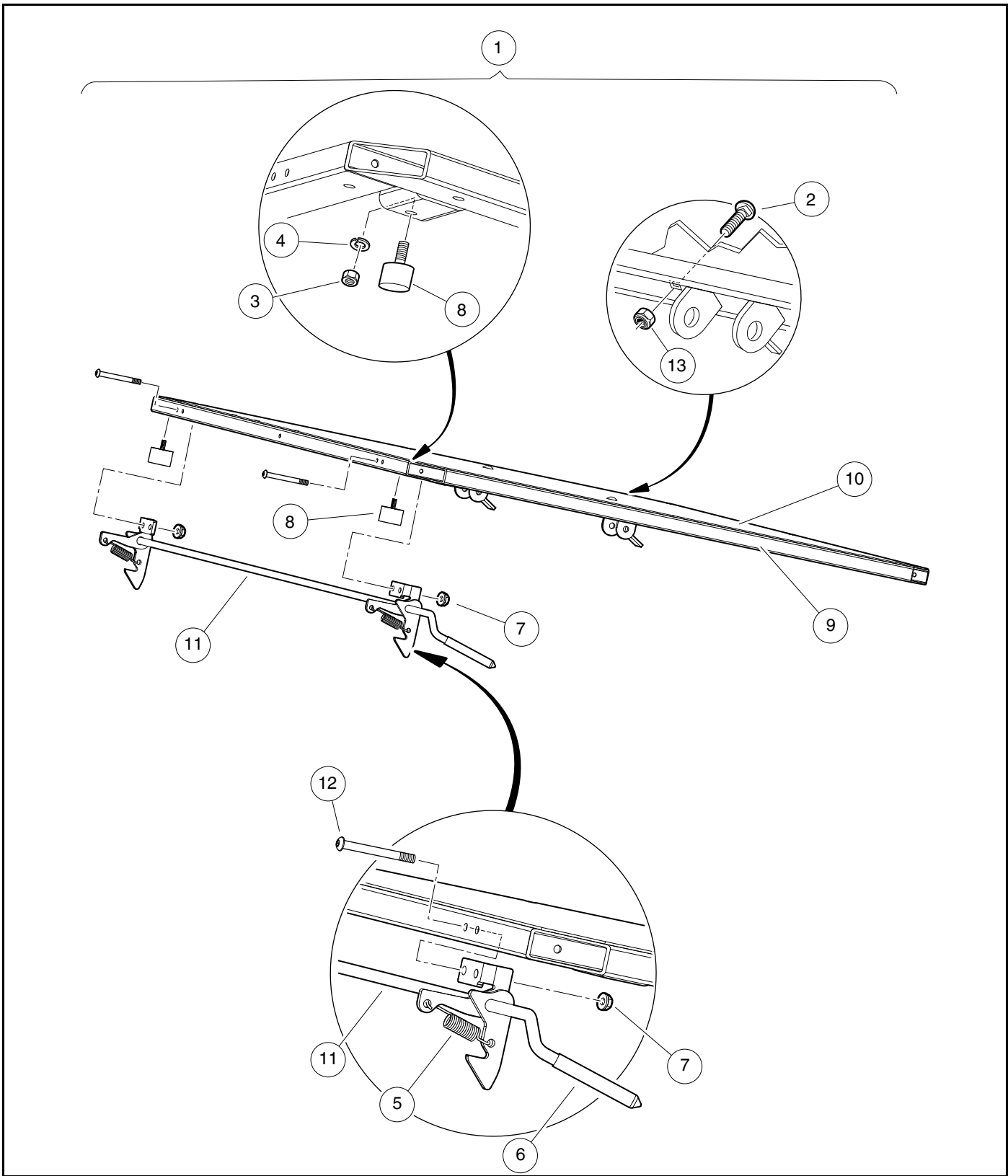

2982

Figure 4-7 Bed Latch Assembly

REAR FENDERS AND TAILSKIRT

See General Warnings on page 1-1.

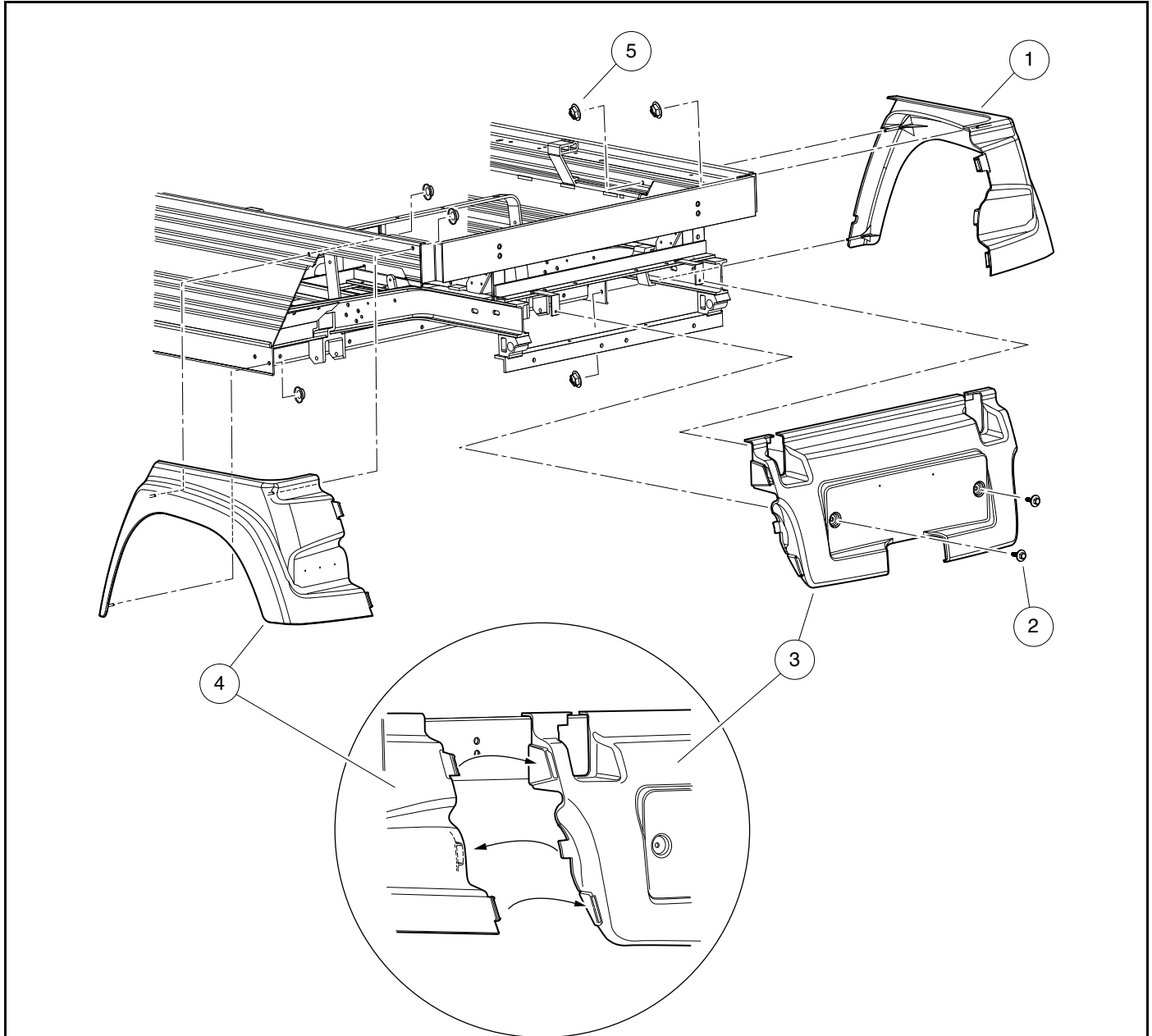

2984

Figure 4-8 Rear Fender and Tailskirt

REAR FENDER AND TAILSKIRT REMOVAL

1. Turn the key switch OFF and remove the key. Place the Forward/Reverse handle in NEUTRAL and set the park brake. Chock the wheels.

2. Disconnect the battery cables and either discharge the controller or disconnect the spark plug wire(s). **See Disconnecting the Batteries – Electric Vehicles, Section 1, Page 1-4. See Disconnecting the Battery-Gasoline Vehicles on page 1-5.**
3. Remove the tilt bed. **See Tilt Bed Removal on page 4-13.**
4. Disconnect the three taillight wires.
5. Using a 10 mm socket, remove the three fasteners (5) that attach the rear fender (4) to vehicle frame (**Figure 4-8, Page 4-17**).
6. Using a 10 mm socket, remove the two M6 screws (2) that attach the tailskirt (3) to the vehicle frame.
7. Remove fenders and tailskirt.

REAR FENDER AND TAILSKIRT INSTALLATION

1. Using a 10 mm socket, install the two screws (2) that attach the tailskirt (3) to the vehicle frame (**Figure 4-8, Page 4-17**). Tighten to 44 in·lb (5 N·m).
2. Using a 10 mm socket, install the three fasteners (5) that attach the rear fender (4) to the vehicle frame. Tighten to 5 in·lb (0.56 N·m). Do not over torque.
3. Connect the taillight wires.
4. Install the two bolts and nuts that secure taillight to the rear fender.
5. Connect the three taillight wires.
6. Install the tilt bed. **See Tilt Bed Installation on page 4-13.**
7. Connect the batteries. **See Connecting the Batteries – Electric Vehicles on page 1-4. See Connecting the Battery-Gasoline Vehicles on page 1-5.**

ELECTRIC BED LIFT

ELECTRIC BED LIFT REMOVAL

NOTE: For vehicles equipped with an electric bed lift.

This procedure requires the aid of an assistant.

1. Disconnect the batteries. **See Disconnecting the Batteries – Electric Vehicles on page 1-4. See Disconnecting the Battery-Gasoline Vehicles on page 1-5.**
2. Raise the bed.
3. Disconnect actuator wires.
4. Remove actuator hardware that secures lift (7) (**Figure 4-9, Page 4-20**).
5. Lower the bed.
6. Remove the hex-head bolts, lock nuts, spacers and bushings (1, 2, 5, 6, 7, and 8) (**Figure 4-10, Page 4-21**).

ELECTRIC BED LIFT INSTALLATION

1. Install hex-head bolts, lock nuts, spacers and bushings (1, 2, 5, 6, 7, and 8) (**Figure 4-10, Page 4-21**).
2. Lift bed.
3. Install actuator hardware that secures lift (7) (**Figure 4-9, Page 4-20**).
4. Connect actuator wires.
5. Lower bed.
6. Connect the batteries. **See Connecting the Batteries – Electric Vehicles on page 1-4. See Connecting the Battery-Gasoline Vehicles on page 1-5.**

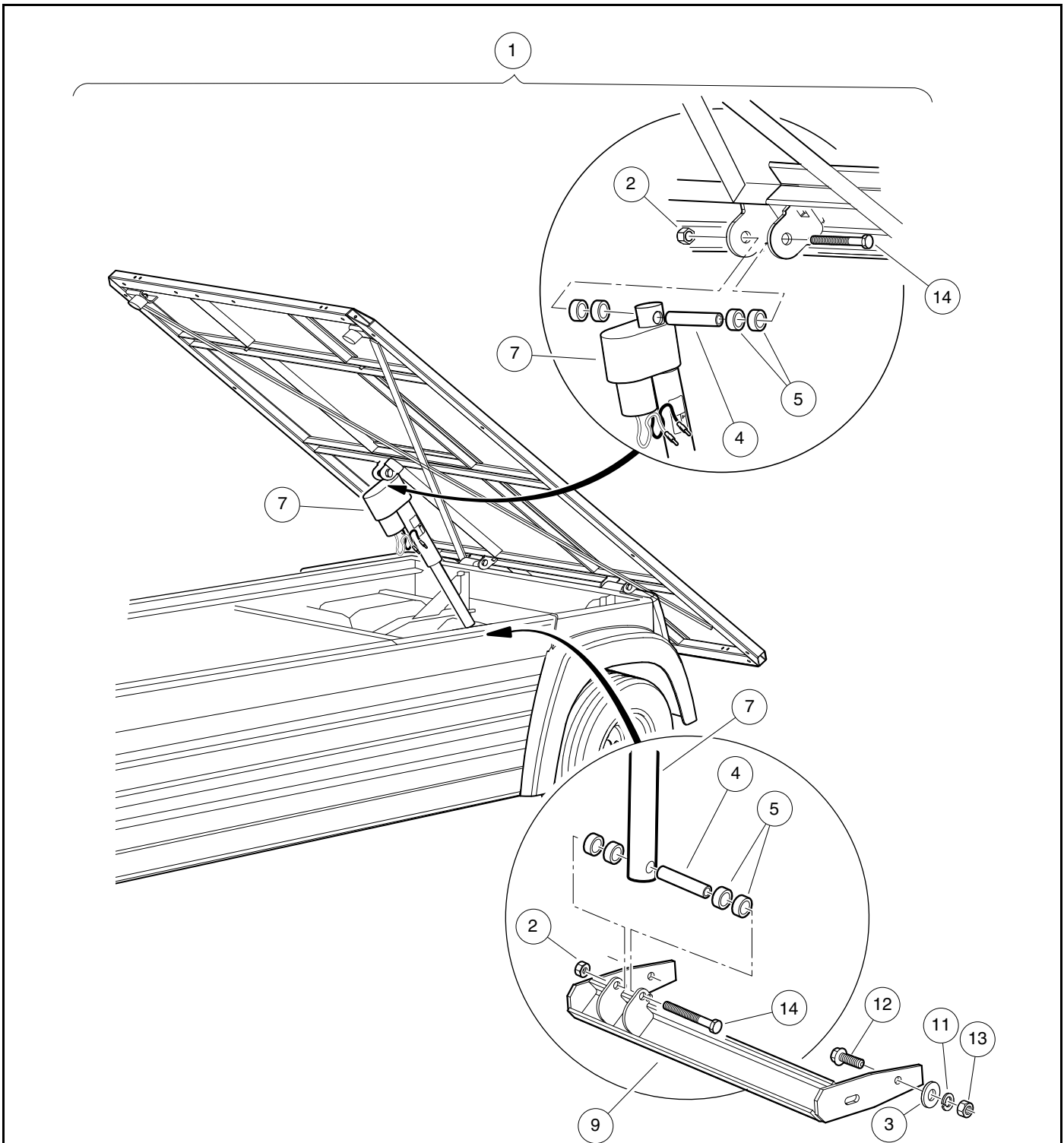

2983

Figure 4-9 Electric Bed Lift

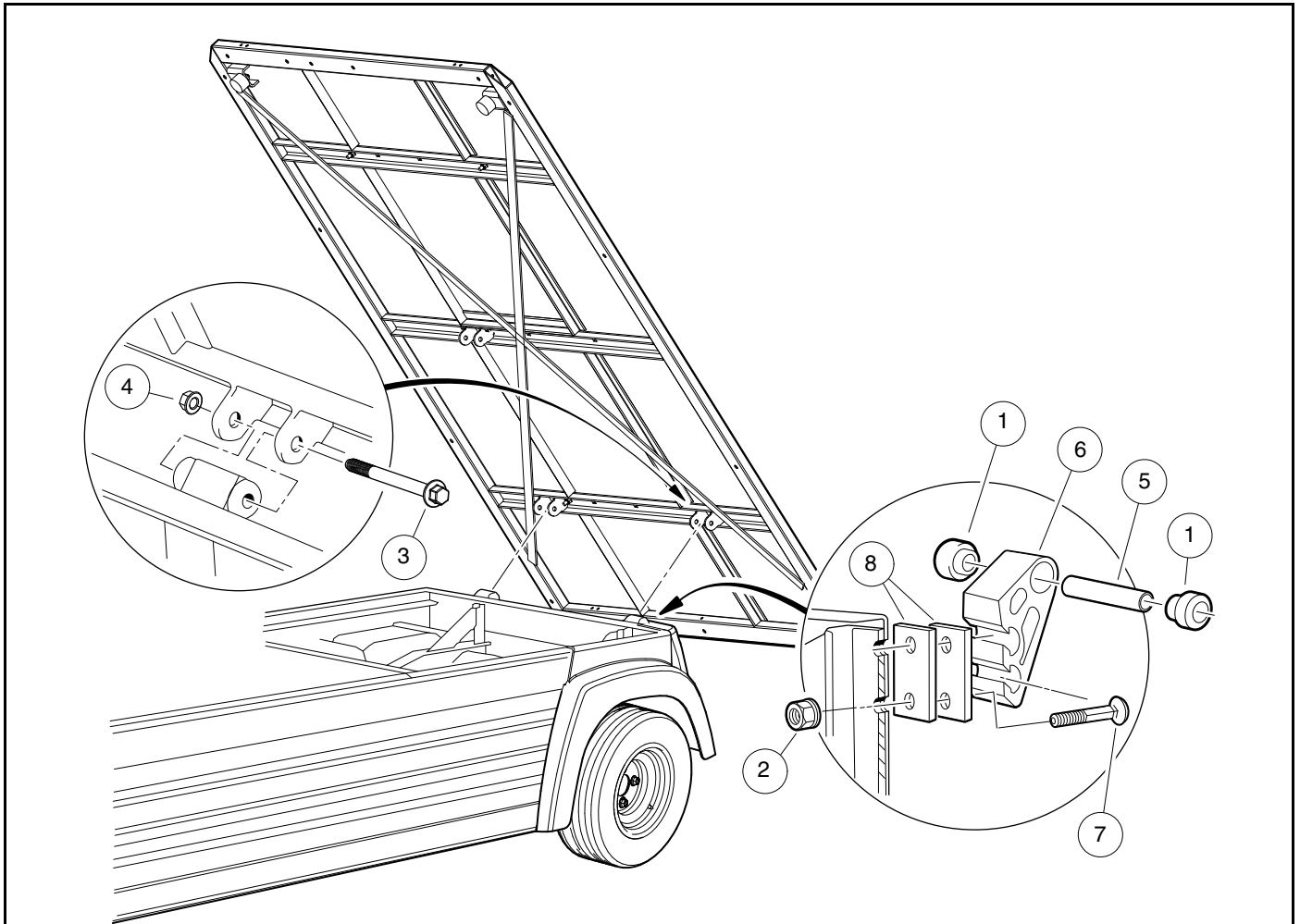

2985

Figure 4-10 Electric Bed Mounting

FLOOR MAT

See General Warnings on page 1-1.

FLOOR MAT REMOVAL

1. Remove the brake and accelerator pedals. **See Accelerator and Brake Pedal Group, Section 5, Page 5-1.**
2. Remove the top edge of the floor mat from the overlapping flange under the dash.
3. Lift the mat from the vehicle.

FLOOR MAT INSTALLATION

1. Install mat into vehicle. Ensure mat is laying flat.
2. Install top edge of the floor mat into the overlapping flange under the dash.
3. Install the brake and accelerator pedals. **See Accelerator and Brake Pedal Group, Section 5, Page 5-1.**

TRAILER HITCH

See General Warnings, Section 1, Page 1-1.

TRAILER HITCH REMOVAL

1. Remove the tailskirt. **See Rear Fender and Tailskirt Removal on page 4-17.**
2. Where the hitch is mounted to frame, remove two nuts, lockwashers, flat washers, and bolts.
3. Where the hitch is mounted to hitch brace, remove the nut, lockwasher, flat washer, and bolt.
4. Remove hitch from vehicle.

TRAILER HITCH INSTALLATION

1. Mount hitch to hitch brace, install nut, lockwasher, flat washer, and bolt.
2. Install hitch to frame, install two nuts, lockwashers, flat washer, and bolts.
3. Tighten hardware to 15 ft·lb (20.3 N·m).
4. Install tailskirt. **See Rear Fender and Tailskirt Installation, Section 4, Page 4-18.**

⚠ DANGER

- See General Warnings on page 1-1.

⚠ WARNING

- See General Warnings on page 1-1.

BRAKE PEDAL AND PARK BRAKE (GAS AND ELECTRIC VEHICLES)

See General Warnings on page 1-1.

BRAKE PEDAL REMOVAL (GAS AND ELECTRIC VEHICLES)

1. Disconnect the battery cables and either discharge the controller or disconnect the spark plug wire(s). **See Disconnecting the Batteries – Electric Vehicles, Section 1, Page 1-4. See Disconnecting the Battery-Gasoline Vehicles on page 1-5.**
2. Place chocks under the rear wheels and lift the front end of the vehicle with a chain hoist or floor jack. Place jack stands under the front cross tube of the vehicle frame and lower the vehicle onto the jack stands. **See following WARNING.**

⚠ WARNING

- **Lift only one end of the vehicle at a time. Use a suitable lifting device (chain hoist or hydraulic floor jack) with 1000 lb (454 kg) minimum lifting capacity. Do not use lifting device to hold vehicle in raised position. Use approved jack stands of proper weight capacity to support the vehicle and chock the wheels that remain on the floor. When not performing a test or service procedure that requires movement of the wheels, lock the brakes.**
3. Remove the brake pedal assembly.
 - 3.1. Disconnect the equalizer rod (5) from the pedal shaft by removing the clevis pin (7) and bow-tie pin (4) (**Figure 5-1, Page 5-2**).
 - 3.2. Remove the nuts (2), flat washers (10), bolts (11), and mounting blocks (3 and 8). If the mounting blocks (3 and 8) show signs of excessive wear or are damaged, they must be replaced with new ones before installing pedal assembly.
 - 3.3. Remove the nut (12) and brake stop bumper (13) and lift pedal assembly (1) through the floorboard (**Figure 5-2, Page 5-3**).

BRAKE PEDAL INSTALLATION (GAS AND ELECTRIC VEHICLES)

1. From the top side of the floorboard, insert the brake pedal assembly (1) through the opening in the floor as shown (**Figure 5-2, Page 5-3**) and install the brake pedal stop bumper (13) (**Figure 5-1, Page 5-2**) on the brake pedal assembly, but do not tighten the jam nut (12) at this time.
2. Secure the equalizer rod (5) to the brake pedal assembly (1) with clevis pin (7) and bow-tie pin (4) as shown.

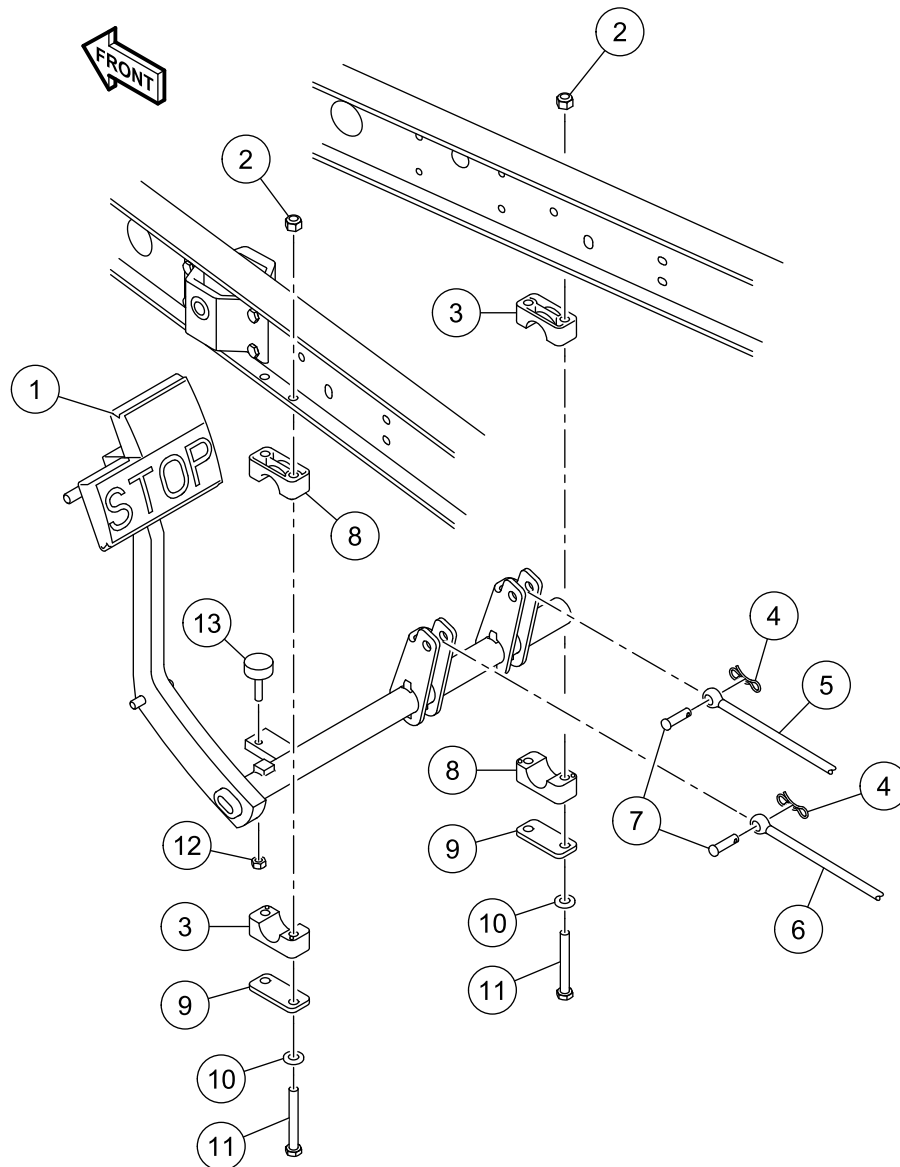

Carryall 500 and 700 Electric Vehicle shown, (Gasoline Vehicle similar)

3208

Figure 5-1 Brake and Park Brake Pedal Assembly and Mounting

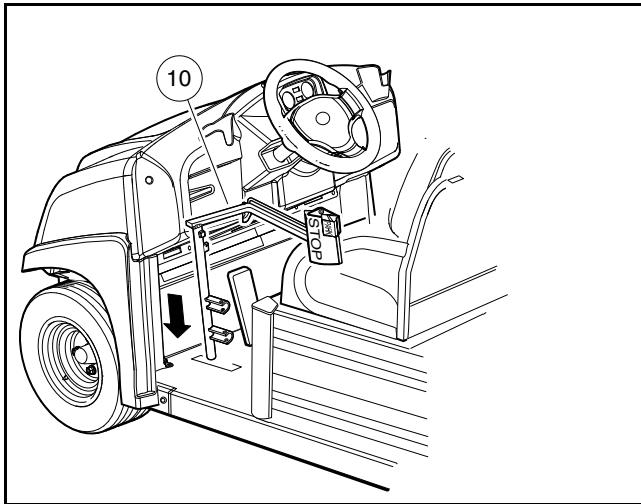

2999

Figure 5-2 Brake Pedal Weldment Through Floor

3. Position and attach brake pedal assembly, mounting blocks (3 and 8), and washers (10) to vehicle frame as shown. Tighten the bolts (11) and nuts to 95 in·lb (10.7 N·m).
4. Tighten the nut (2) on the equalizer rod (1) so that brake pedal free-play is from 1/4 inch to 1/2 inch (6 mm to 13 mm) (**Figure 5-3, Page 5-3**). See following **NOTE**.

NOTE: Brake pedal free-play is the distance the brake pedal can be pressed before the brake actuator arm moves.

5. Tighten the jam nut (3) while holding the adjustment nut (2) in the correct position.
6. Adjust the pedal group. Refer to the appropriate adjustment procedure:
 - For gasoline vehicles, see **Pedal Group Adjustment – Gasoline Vehicles** on page 5-10.
 - For electric vehicles, see **Pedal Group Adjustment – Electric Vehicles** on page 5-16.

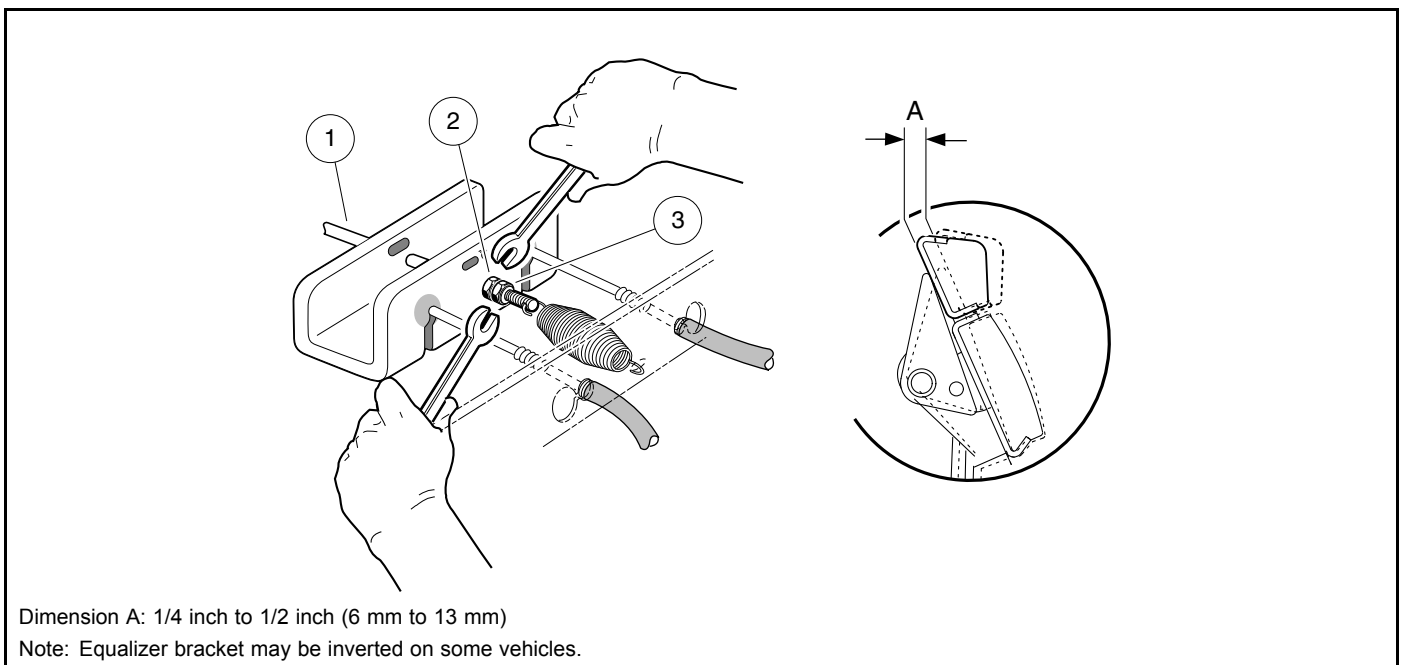

1369

Figure 5-3 Brake Pedal Free-Play Adjustment

PARK BRAKE REMOVAL (GAS AND ELECTRIC VEHICLES)

1. Disconnect the battery cables and either discharge the controller or disconnect the spark plug wire(s). **See Disconnecting the Batteries – Electric Vehicles, Section 1, Page 1-4. See Disconnecting the Battery-Gasoline Vehicles on page 1-5.**
2. Place chocks under the rear wheels and lift the front end of the vehicle with a chain hoist or floor jack. Place jack stands under the front cross tube of the vehicle frame and lower the vehicle onto the jack stands. **See following WARNING.**

⚠ WARNING

- **Lift only one end of the vehicle at a time. Use a suitable lifting device (chain hoist or hydraulic floor jack) with 1000 lb (454 kg) minimum lifting capacity. Do not use lifting device to hold vehicle in raised position. Use approved jack stands of proper weight capacity to support the vehicle and chock the wheels that remain on the floor. When not performing a test or service procedure that requires movement of the wheels, lock the brakes.**

3. Remove the park brake assembly.
 - 3.1. To remove the park brake rod and pawl assembly (17 through 20), remove the push nut (19) and disconnect the ball joint sleeve (21) from the park brake pedal (1) (**Figure 5-4, Page 5-4**). **See following NOTE.**

NOTE: New push nuts (19) and (32) must be used when reassembling the park brake.

- 3.2. To remove the park brake pedal (1), remove the push retainer nut (32), disconnect the torsion spring (22), and slide the pedal off of the shaft. **See preceding NOTE.**
- 3.3. Inspect all parts for wear and damage and replace as necessary.

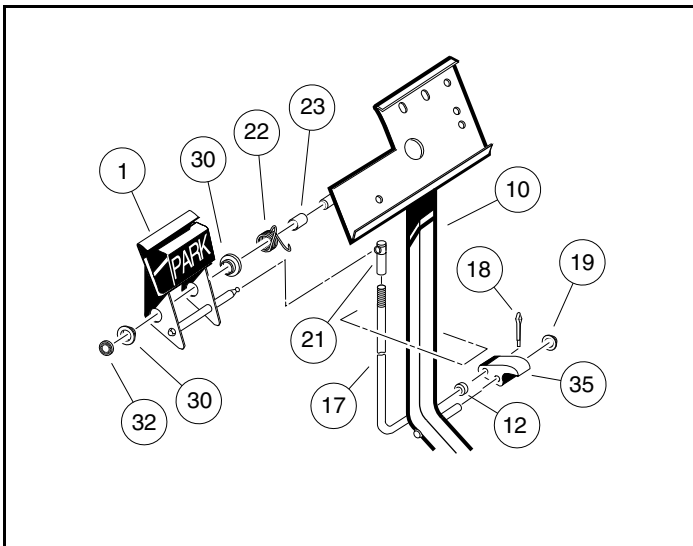

Figure 5-4 Park Brake Assembly

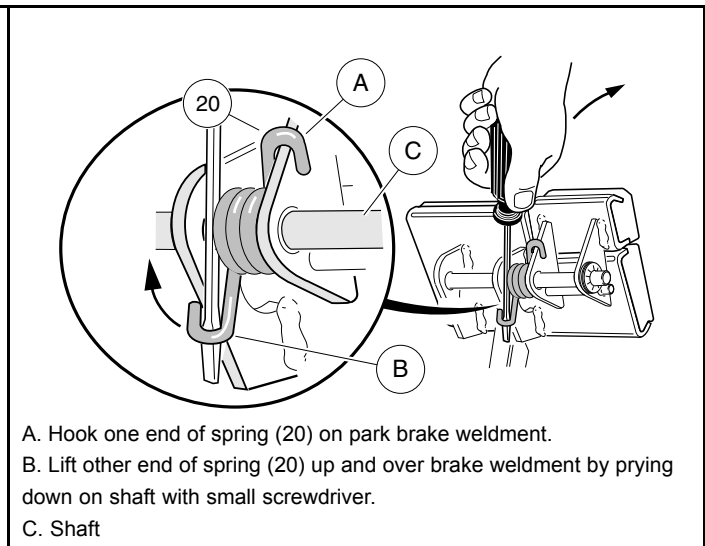

Figure 5-5 Torsion Spring Installation

PARK BRAKE INSTALLATION (GAS AND ELECTRIC VEHICLES)

1. From the bottom side of the floorboard, insert the park brake rod (17) through the brake pedal assembly opening. Then install the park brake pawl (35) onto the shaft on the brake pedal assembly (10) and also insert the park brake rod (17) into the park brake pawl (**Figure 5-4, Page 5-4**).
2. Install the push nut (19) on to the park brake pawl shaft.
3. Install the spacer (23) and torsion spring (22) on the park brake pedal shaft on the brake pedal assembly.

4. Install the two bushings (30) in the park brake pedal and position the park brake pedal on the shaft on the brake pedal assembly weldment (10). Then attach the ends of the torsion spring to the park brake pedal and to the brake pedal weldment as shown (**Figure 5-5, Page 5-4**).
5. Install the push nut (32) on the park brake pedal shaft (**Figure 5-4, Page 5-4**).
6. Connect park brake rod (17) with ball joint (21) to the ball stud on the park brake pedal assembly.
7. Adjust park brake ratchet/pawl gap and pawl engagement. Refer to the appropriate adjustment procedure:
 - **For gasoline vehicles, see Pedal Group Adjustment – Gasoline Vehicles on page 5-10.**
 - **For electric vehicles, see Pedal Group Adjustment – Electric Vehicles on page 5-16.**

ACCELERATOR PEDAL – GASOLINE VEHICLES

See General Warnings on page 1-1.

ACCELERATOR PEDAL REMOVAL – GASOLINE VEHICLES

1. Disconnect battery and spark plug wire(s). **See Disconnecting the Battery-Gasoline Vehicles on page 1-5.**
2. Place chocks under the rear wheels and lift the front end of the vehicle with a chain hoist or floor jack. Place jack stands under the front cross tube of the vehicle frame and lower the vehicle onto the jack stands. **See following WARNING.**

▲ WARNING

- **Lift only one end of the vehicle at a time. Use a suitable lifting device (chain hoist or hydraulic floor jack) with 1000 lb (454 kg) minimum lifting capacity. Do not use lifting device to hold vehicle in raised position. Use approved jack stands of proper weight capacity to support the vehicle and chock the wheels that remain on the floor. When not performing a test or service procedure that requires movement of the wheels, lock the brakes.**

3. Disconnect the accelerator rod assembly (17, 24, and 25) (**Figure 5-6, Page 5-6**) at the front and rear ball studs and remove it from the vehicle.
4. Use a 9/16-inch (14 mm) socket and 9/16-inch (14 mm) wrench to remove the nut (7), two washers (5), and bolt (4) securing the accelerator pedal (1) to the pivot rod (6).
5. Remove the nut (10) and ball stud (8) from the accelerator pivot rod assembly (6).
6. Slide the spring retainer (11) off of the accelerator pivot rod.
7. Inspect the pivot support bearing (9) for wear and replace if necessary.
8. Use a marker to mark the position of the park brake ratchet (23) on the accelerator pivot rod (6). **See following NOTE.**

NOTE: *Failure to mark position of the ratchet could cause it to be reinstalled improperly, resulting in improper adjustment and possible failure of the park brake.*

9. Remove the lock nut (26) from the accelerator pivot rod (**Figure 5-6, Page 5-6**).
10. Press the brake pedal slightly and slide the park brake ratchet (23) toward the end of the accelerator pivot rod. Rotate the ratchet and remove it from the pivot rod.
11. Remove the pivot rod (6) and spacer (20) from the accelerator pivot rod supports (21).
12. Inspect the accelerator pivot rod supports (21) for wear and damage and replace if necessary. If the pivot rod supports do not require replacement, loosen, but do not remove, the four bolts (22) and lock nuts (18) to make installation of the pivot rod easier.

13. Remove the accelerator pedal (1) from the vehicle.
14. Inspect all parts for wear and damage. Replace as necessary.

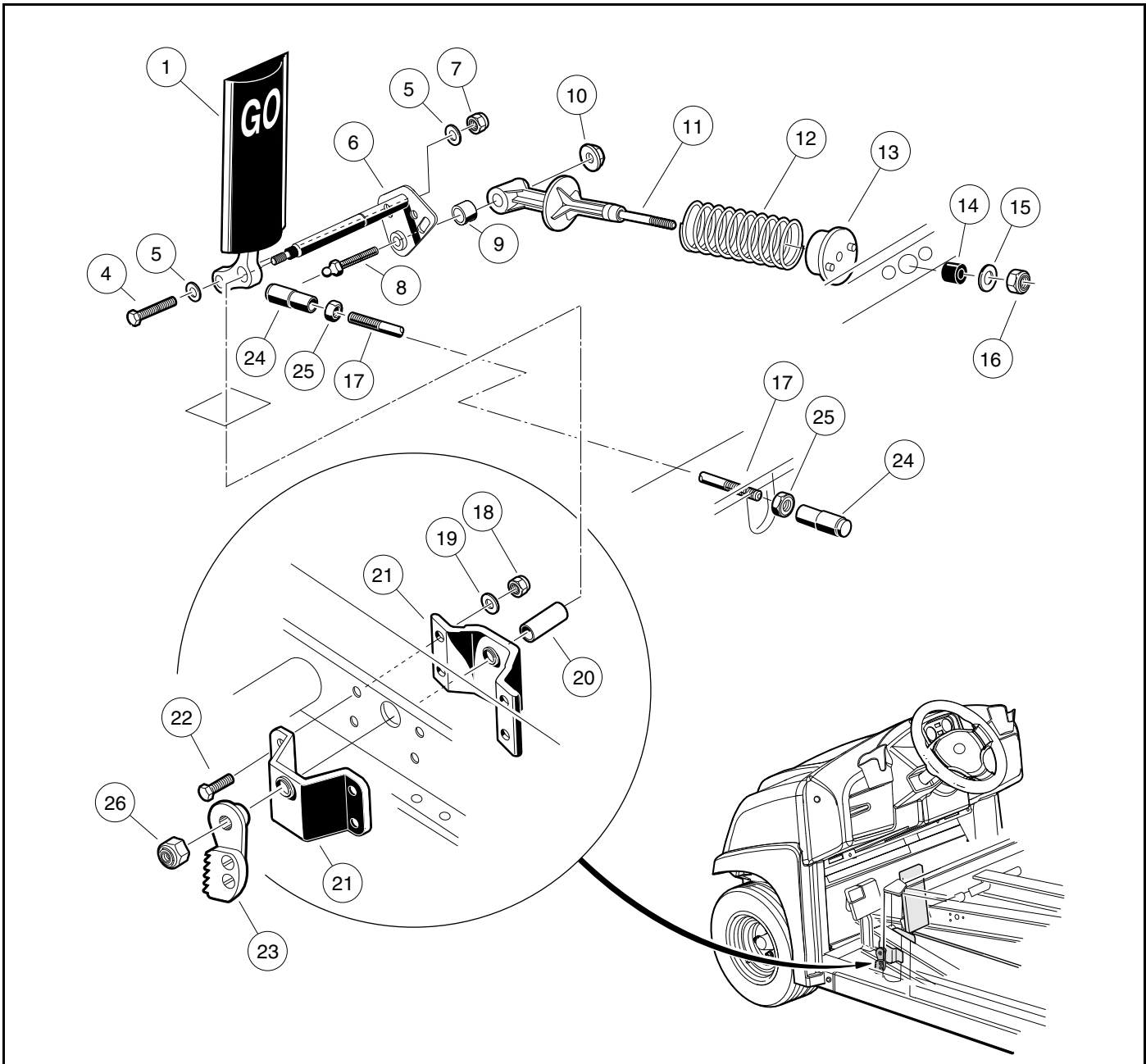

3000

Figure 5-6 Accelerator Pedal – Gasoline Vehicles

ACCELERATOR PEDAL INSTALLATION – GASOLINE VEHICLES

1. If the accelerator pivot rod supports were replaced, position the supports (21) on the vehicle frame and install the four bolts (22), flat washers (19), and lock nuts (18). Finger-tighten nuts at this time (**Figure 5-6, Page 5-6**).
2. Insert the lower end of the accelerator pedal (1) through the floorboard and install the accelerator pivot rod (6) through the uppermost hole in the pedal.

3. Install the plastic spacer (20) on the pivot rod (6).
4. Insert the pivot rod through the pivot rod supports on the vehicle frame.
5. Tighten the four bolts (22) attaching the pivot rod supports to the frame to 75 in·lb (8.5 N·m).
6. Install the bolt (4), two washers (5), and a new lock nut (7) through the lower hole in the pedal and through the pivot rod. Finger-tighten nut at this time.
7. Install the ball stud (8) through the pivot rod. Install the bearing (9) and spring retainer (11) onto the ball stud. Secure these parts with the nut (10). Tighten the nut to 50 in·lb (5.7 N·m).
8. Press the brake pedal slightly, and with the park brake ratchet oriented so that the tip of the ratchet is pointed toward the rear of vehicle, slide the ratchet onto the pivot rod (do not slide the ratchet onto the pivot rod splines). Release the brake pedal and allow the ratchet to rotate until its tip is pointed downward (**Figure 5-7, Page 5-7**). The ratchet should now rotate freely on the rod.

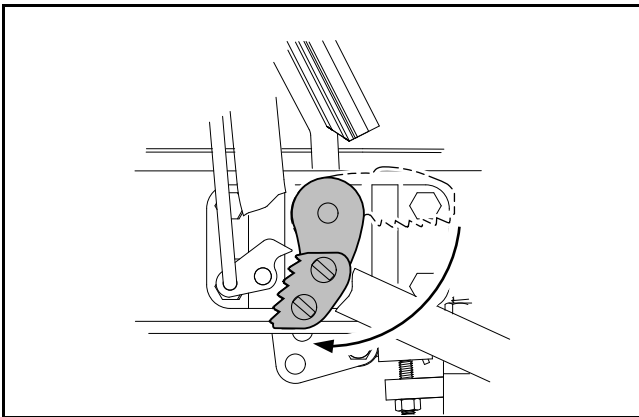

Figure 5-7 Ratchet Installation

9. Rotate the ratchet clockwise until it touches the park brake pawl, then slide the ratchet onto the splines of the pivot rod (it may be necessary to push the pivot rod toward the driver side of the vehicle to make the splines accessible). The ratchet may have to be rotated counterclockwise slightly to align the splines.
10. Install the nylon lock nut (26) on the pivot rod and tighten the nut to 18 ft·lb (24 N·m) (**Figure 5-6, Page 5-6**).
11. Install the accelerator rod assembly (17, 24, and 25).
12. Adjust the accelerator pedal height and accelerator rod. **See Pedal Group Adjustment – Gasoline Vehicles on page 5-10.**

ACCELERATOR PEDAL – ELECTRIC VEHICLES

See General Warnings on page 1-1.

ACCELERATOR PEDAL REMOVAL – ELECTRIC VEHICLES

1. Disconnect the batteries and discharge the controller. **See Disconnecting the Batteries – Electric Vehicles, Section 1, Page 1-4.**
2. Place chocks under the rear wheels and lift the front end of the vehicle with a chain hoist or floor jack. Place jack stands under the front cross tube of the vehicle frame and lower the vehicle onto the jack stands. **See following WARNING.**

⚠ WARNING

- Lift only one end of the vehicle at a time. Use a suitable lifting device (chain hoist or hydraulic floor jack) with 1000 lb (454 kg) minimum lifting capacity. Do not use lifting device to hold vehicle in raised position. Use approved jack stands of proper weight capacity to support the vehicle and chock the wheels that remain on the floor. When not performing a test or service procedure that requires movement of the wheels, lock the brakes.
3. Remove the MCOR (2) and drive bar (3) as instructed (**Figure 5-8, Page 5-9**). See **MCOR Removal, Section 13, Page 13-6**.
 4. Use a 9/16-inch (14 mm) socket wrench to remove the nut (7), two washers (5), and bolt (4) securing the accelerator pedal (1) to the pivot rod (6) (**Figure 5-8, Page 5-9**).
 5. Remove the nut (10) and bolt (8) from the accelerator pivot rod assembly (6).
 6. Slide the spring retainer (11) off of the accelerator pivot rod.
 7. Inspect the pivot support bearing (9) for wear and replace if necessary.
 8. Use a marker to mark the position of the park brake ratchet (24) on the accelerator pivot rod (6). **See following NOTE.**

NOTE: Failure to mark position of the ratchet could cause it to be installed improperly, resulting in improper adjustment and possible failure of the park brake.

9. Remove the lock nut (23) from the accelerator pivot rod.
10. Press the brake pedal slightly and slide the park brake ratchet (24) toward the end of the accelerator pivot rod. Rotate the ratchet and remove it from the pivot rod.
11. Remove the pivot rod (6) and spacer (20) from the accelerator pivot rod supports (21) (**Figure 5-8, Page 5-9**).
12. Inspect the accelerator pivot rod supports (21) for wear and damage and replace as necessary. If the pivot rod supports do not require replacement, loosen, but do not remove, the four bolts (22) and lock nuts (15) to make installation of the pivot rod easier.
13. Remove the accelerator pedal (1) from the vehicle.
14. Inspect all parts for wear and damage. Replace as necessary.

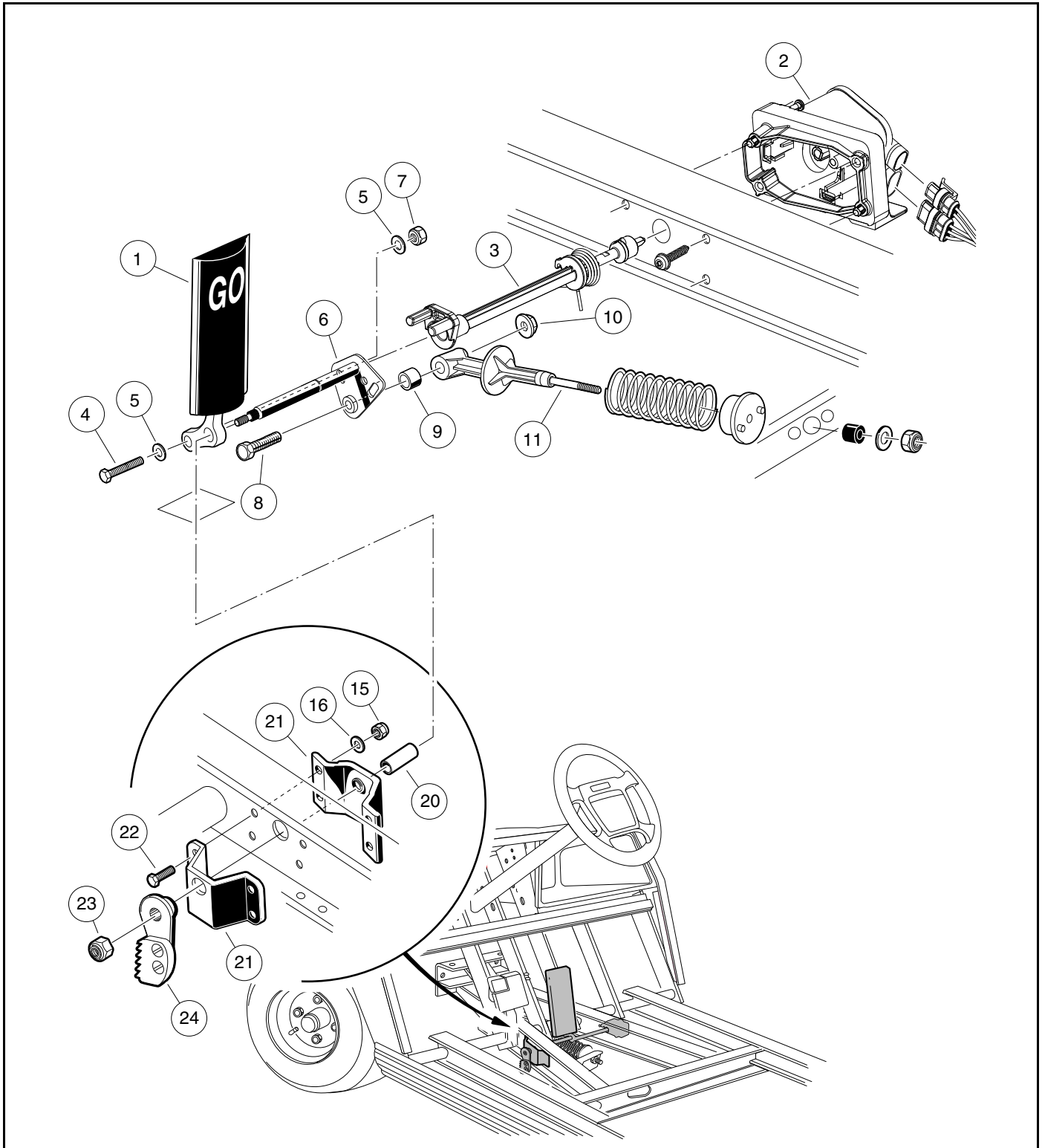

2642

Figure 5-8 Accelerator Pedal – Electric Vehicle with MCOR

ACCELERATOR PEDAL INSTALLATION – ELECTRIC VEHICLES

1. If the accelerator pivot rod supports were replaced, position the supports (21) on the vehicle frame and install the four bolts (22), flat washers (16), and lock nuts (15) (**Figure 5-8, Page 5-9**). Finger-tighten nuts at this time.
2. Insert the lower end of the accelerator pedal (1) through the floorboard and install the accelerator pivot rod (6) through the uppermost hole in the pedal.
3. Install plastic spacer (20) on pivot rod (6).
4. Insert the pivot rod through the pivot rod supports (21) on the vehicle frame.
5. Tighten the four bolts (22) attaching the pivot rod supports to the frame to 75 in·lb (8.5 N·m).
6. Insert the bolt (4), two washers (5), and a new lock nut (7) through the lower hole in the pedal and through the pivot rod. Finger-tighten lock nut at this time.
7. Install the bolt (8) through the pivot rod (6) bearing (9) and spring retainer (11). Secure these parts with the nut (10). Tighten the nut to 50 in·lb (5.5 N·m).
8. Press the brake pedal slightly, and with the park brake ratchet oriented so that the tip of the ratchet is pointed toward the rear of the vehicle, slide the ratchet onto the pivot rod (do not slide the ratchet onto the pivot rod splines). Release the brake pedal and allow the ratchet to rotate until its tip is pointed downward (**Figure 5-7, Page 5-7**). The ratchet should now rotate freely on the rod.
9. Rotate the ratchet clockwise until it touches the park brake pawl, then slide the ratchet onto the splines of the pivot rod (it may be necessary to push the pivot rod toward the driver side of the vehicle to make the splines accessible). The ratchet may have to be rotated counterclockwise slightly to align the splines.
10. Install lock nut (23) on pivot rod (**Figure 5-8, Page 5-9**). Tighten to 18 ft·lb (24.5 N·m).
11. Install the MCOR (2) and drive bar (3) as instructed. **See MCOR Installation, Section 13, Page 13-6.**
12. Adjust the accelerator pedal height. **See Pedal Group Adjustment – Electric Vehicles on page 5-16.**

PEDAL GROUP ADJUSTMENT – GASOLINE VEHICLES

See General Warnings on page 1-1.

1. Disconnect battery and spark plug wire(s). **See Disconnecting the Battery-Gasoline Vehicles on page 1-5.**
2. Adjust brake pedal height.
 - 2.1. Chock wheels and release park brake. Lift rear of vehicle and place jack stands under the axle tubes to support the vehicle.
 - 2.2. To provide slack in the brake cables, loosen the equalizer retaining nuts (1) on the equalizer rod (2) (**Figure 5-9, Page 5-11**).

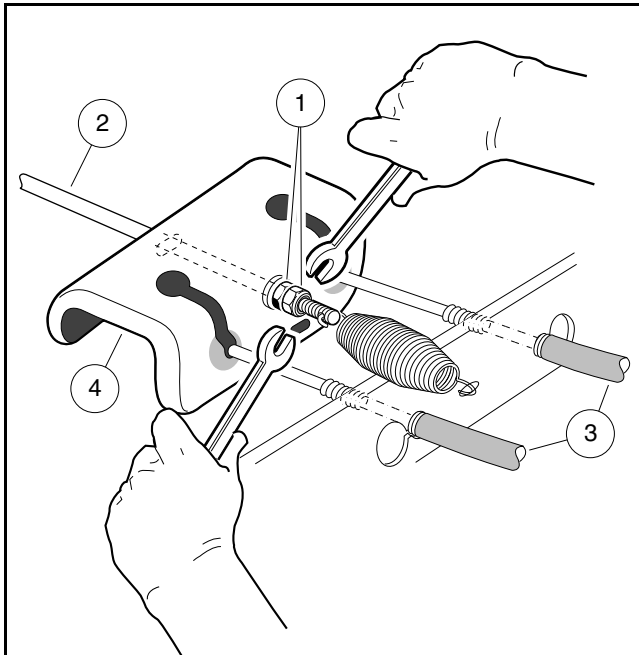

Figure 5-9 Loosen Rear Brake Equalizer Rod Nuts

- 2.3. Loosen the brake stop jam nut (31), then relieve pedal pressure on the stop by pushing down slightly on the pedal. Next, adjust the brake stop bumper (22) up or down (**Figure 5-10, Page 5-11**). Adjusting the bumper upward decreases distance between pedal and floorboard. Adjusting the bumper downward increases distance between pedal and floorboard. Proper brake pedal height is 6 inches (15.2 cm) (**Figure 5-11, Page 5-11**).
- 2.4. Tighten the jam nut (31) to 8 ft·lb (9.5 N·m) (**Figure 5-10, Page 5-11**).

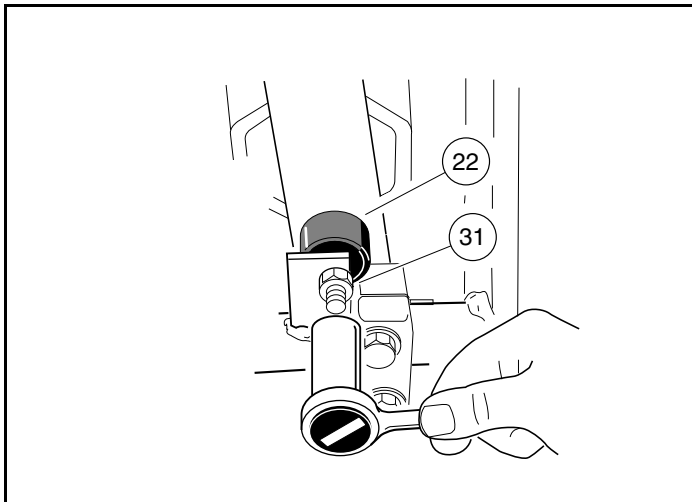

Figure 5-10 Brake Pedal Height Adjustment

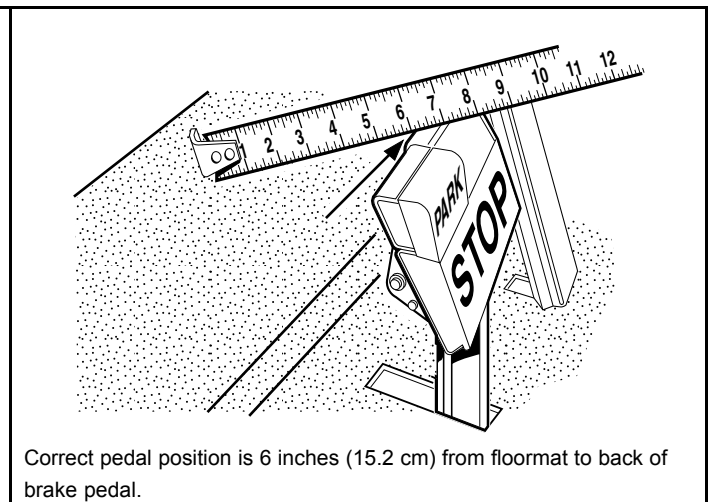

Figure 5-11 Brake Pedal Height Measurement

3. Adjust brake pedal free play. **See following NOTE.**

NOTE: Brake pedal free play is the distance the brake pedal can be pressed before the brake actuator arm (at the brake cluster) moves.

- 3.1. Measure perpendicularly from the floorboard to the back of the brake pedal, then press the brake pedal and measure the distance that the pedal moves before all of the slack is taken out of the brake cables (**Figure 5-11, Page 5-11**).

- 3.2. Tighten the nut (2) on the equalizer rod (1) so that the brake pedal free play is 1/4 inch to 1/2 inch (6 mm to 13 mm) (**Figure 5-3, Page 5-3**).
- 3.3. Tighten the jam nut (3) while holding the adjustment nut (2) in the correct position.
4. Adjust park brake ratchet/pawl gap and pawl engagement.
 - 4.1. Inspect the park brake pawl and ratchet for excessive wear, grooves, cracks, or chips. If either the pawl or ratchet is damaged, both must be replaced.
 - 4.2. Adjust retaining nut (7) on spring support rod until there is a 0.060 inch (1.5 mm) gap between the pawl and the tips of the ratchet teeth. Use a feeler gauge to verify the gap (**Figure 5-12, Page 5-12**). The gap should be consistent through range of pawl movement. If the gap is not consistent, loosen the four bolts (6) securing the accelerator pivot rod supports and adjust the supports. If the gap becomes smaller as the park brake pedal is pressed, move the pivot rod supports slightly rearward until the gap is consistent. If the gap becomes larger as the park brake pedal is pressed, move the pivot rod supports slightly forward until gap is consistent. **See following NOTE.**

NOTE: The accelerator rod must also be checked if the ratchet/pawl gap is adjusted. **See step 6.**

The accelerator rod must be disconnected before proceeding to the next step.

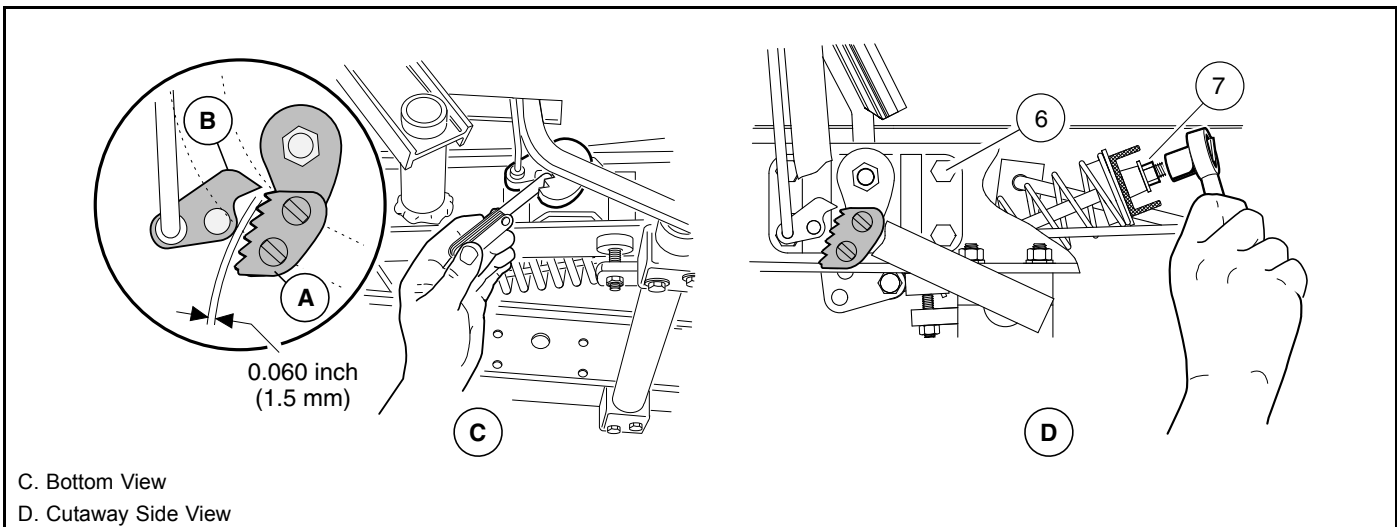

Figure 5-12 Park Brake Ratchet/Pawl Gap Adjustment

- 4.3. With the park brake unlocked, measure and note the distance from the top of the accelerator pedal to the floorboard, then lock the park brake (**Figure 5-13, Page 5-13**).
- 4.4. With the park brake locked, make sure at least 75% of ratchet tooth length engages the pawl (**Figure 5-14, Page 5-13**). Tooth engagement should be between the two lines marked on the pawl.

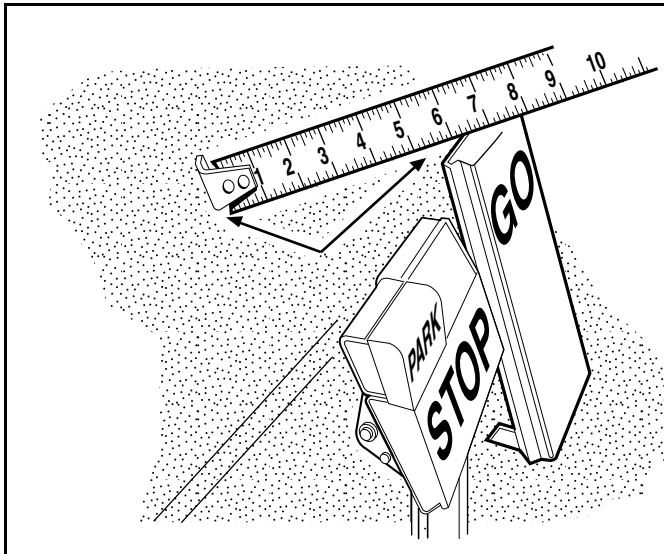
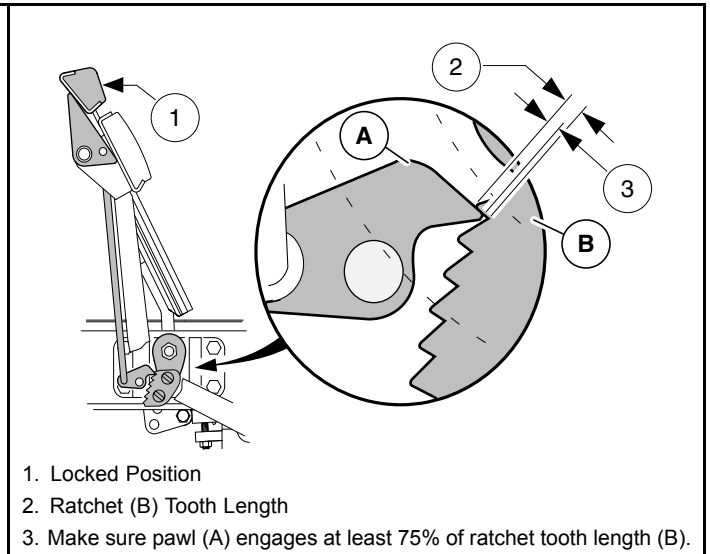

Figure 5-13 Accelerator Pedal Height Measurement



1. Locked Position
2. Ratchet (B) Tooth Length
3. Make sure pawl (A) engages at least 75% of ratchet tooth length (B).

Figure 5-14 Ratchet/Pawl Tooth Engagement

- 4.5. With park brake still locked, measure the distance from the top of accelerator pedal to floorboard. If the measurement has changed, ratchet tooth engagement is too deep and must be adjusted.
- 4.6. If ratchet/pawl engagement must be adjusted, disconnect the ball joint at the top of the brake rod and rotate the ball joint sleeve clockwise to increase engagement or counterclockwise to decrease engagement. Reconnect ball joint (**Figure 5-15, Page 5-13**).
- 4.7. If the accelerator push rod was disconnected from the accelerator pedal, reconnect it.
- 4.8. Check for proper brake operation prior to driving the vehicle.

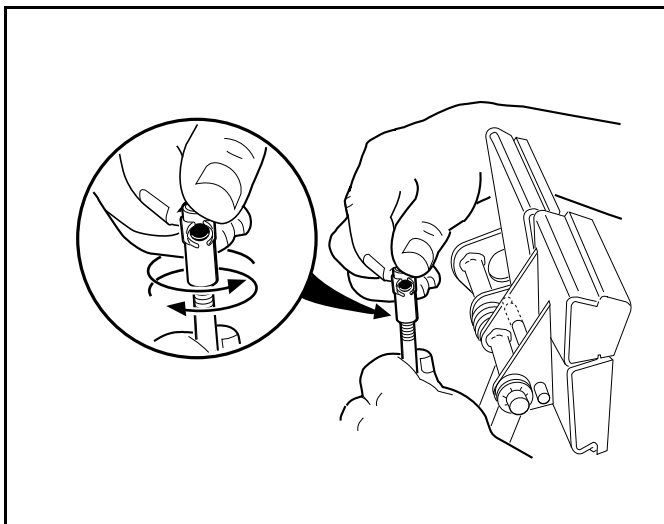
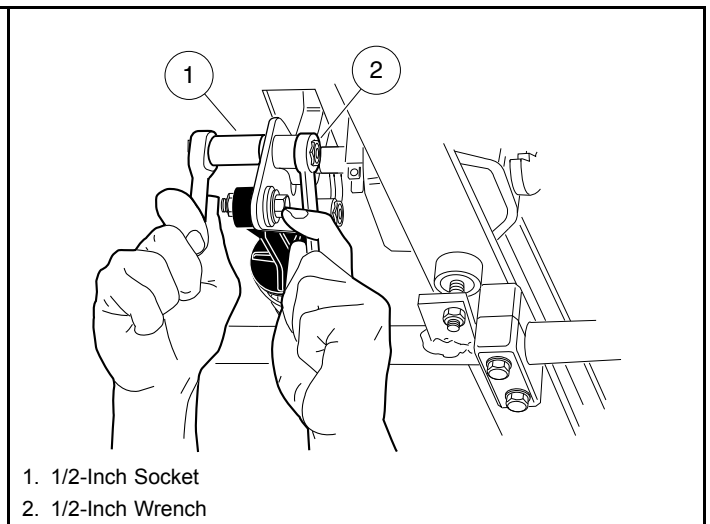

Figure 5-15 Brake Rod Adjustment



1. 1/2-Inch Socket
2. 1/2-Inch Wrench

Figure 5-16 Accelerator Pedal Height Adjustment

5. Adjust accelerator pedal height.
 - 5.1. Loosen the nut and bolt (**Figure 5-16, Page 5-13**) securing the accelerator pedal to the pivot plate. Clamp the accelerator pedal adjustment tool (CC P/N 101871001) to the accelerator pedal, with the end marked *accelerator pedal height* closest to the floorboard. Press the accelerator pedal until the end of the tool rests against the floorboard; pedal height should be 5-5/8 inches (14.3 cm). Use a rubber strap to hold pedal in position against the floorboard and then tighten nut to 26 ft·lb (35.3 N·m) (**Figure 5-17, Page 5-14**).

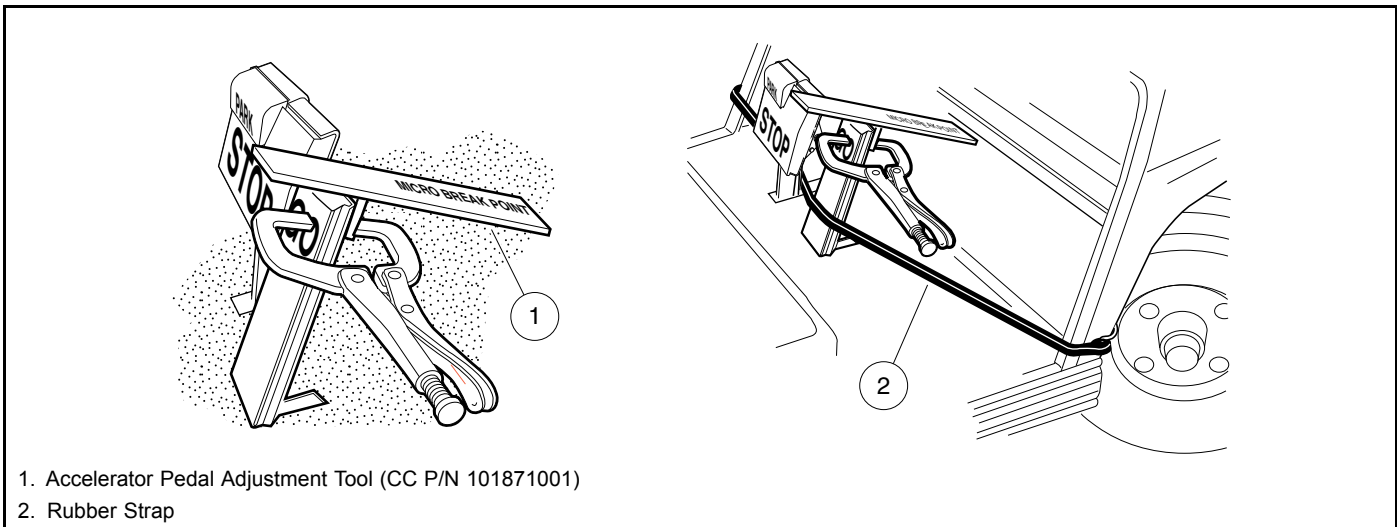

Figure 5-17 Accelerator Pedal Height Adjustment

6. Adjust the accelerator rod. **See following DANGER.**

⚠ DANGER

- Before servicing, turn the key switch to the OFF position and place the Forward/Reverse handle in the NEUTRAL position.
- To prevent accidentally starting the vehicle, disconnect the battery cables as instructed. See *Disconnecting the Battery-Gasoline Vehicles* on page 1-5. This will prevent the possibility of the vehicle running over you when you are adjusting the accelerator rod.

- 6.1. Remove the electrical box screw and cover. **See preceding DANGER.**
- 6.2. Loosen the jam nuts (25) and disconnect the accelerator rod (17) at the accelerator pedal (**Figure 5-6, Page 5-6**). Adjust the length of the rod to obtain an accelerator cable cam position of 0° to 5° as shown (**Figure 5-18, Page 5-15**). **See following CAUTION.**

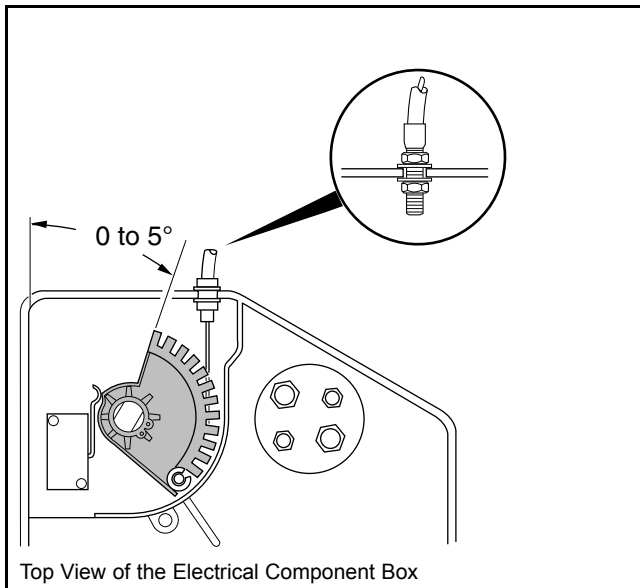

3016

Figure 5-18 Accelerator Cable

⚠ CAUTION

- After accelerator rod adjustment, make sure that approximately the same number of threads are exposed at each end of the accelerator rod.
- If the lever on the limit switch in the electrical box is bent, replace the limit switch.
- When loosening jam nuts on the accelerator rod with one end disconnected, hold the disconnected accelerator rod with locking pliers.
- When tightening jam nuts on the accelerator rod, hold the disconnected ball joint with locking pliers.

6.3. Reconnect the accelerator rod at the accelerator pedal.

6.4. Before tightening jam nuts on accelerator rod, set park brake to first ratchet and pawl position. Press accelerator pedal and make sure the following events occur in the exact order shown:

EVENT	APPROXIMATE PEDAL TRAVEL
Park brake release	2° to 4°
Solenoid activation	4° to 8°
Throttle body actuation	8° to 12°

6.5. If the events above occur as they should, hold the ball joint at each end of the accelerator rod with pliers and tighten the accelerator rod jam nut against it.

6.6. Ensure that the events occur as described in the table above. **See following NOTE.**

NOTE: After the pedal group and accelerator rod are adjusted, the final governed engine RPM should be set. **See Engine RPM Adjustment, Section 23, Page 23-13.**

6.7. Install the electrical box cover and screw.

7. Adjust the brakes. **See Brake Adjustment, Section 6, Page 6-6.**

8. Connect the battery cables. **See Connecting the Batteries – Electric Vehicles, Section 1, Page 1-4.**

PEDAL GROUP ADJUSTMENT – ELECTRIC VEHICLES

See General Warnings on page 1-1.

1. Disconnect the batteries and discharge the controller. **See Disconnecting the Batteries – Electric Vehicles, Section 1, Page 1-4.**
2. Adjust brake pedal height.
 - 2.1. Chock wheels and release park brake. Lift rear of vehicle and place jack stands under the axle tubes to support the vehicle.
 - 2.2. To provide slack in the brake cables, loosen the equalizer retaining nuts (1) on the equalizer rod (2) (**Figure 5-19, Page 5-16**).

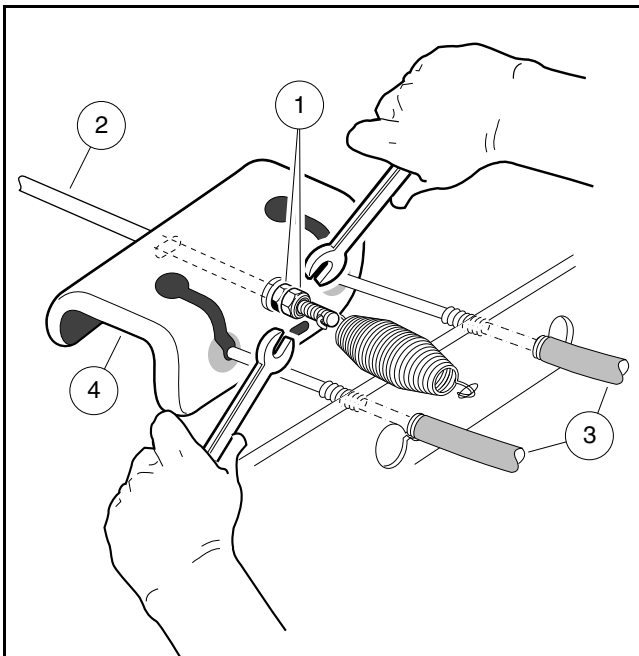

1400-18100-10209

Figure 5-19 Loosen Rear Brake Equalizer Rod Nuts

- 2.3. Loosen the brake stop jam nut (31), then relieve pedal pressure on the stop by pushing down slightly on the pedal. Next, adjust the brake stop bumper (22) up or down (**Figure 5-20, Page 5-17**). Adjusting the bumper upward decreases distance between pedal and floorboard. Adjusting the bumper downward increases distance between pedal and floorboard. Proper brake pedal height is 6 inches (15.2 cm) (**Figure 5-21, Page 5-17**).
- 2.4. Tighten the jam nut (31) to 8 ft·lb (9.5 N·m) (**Figure 5-20, Page 5-17**).

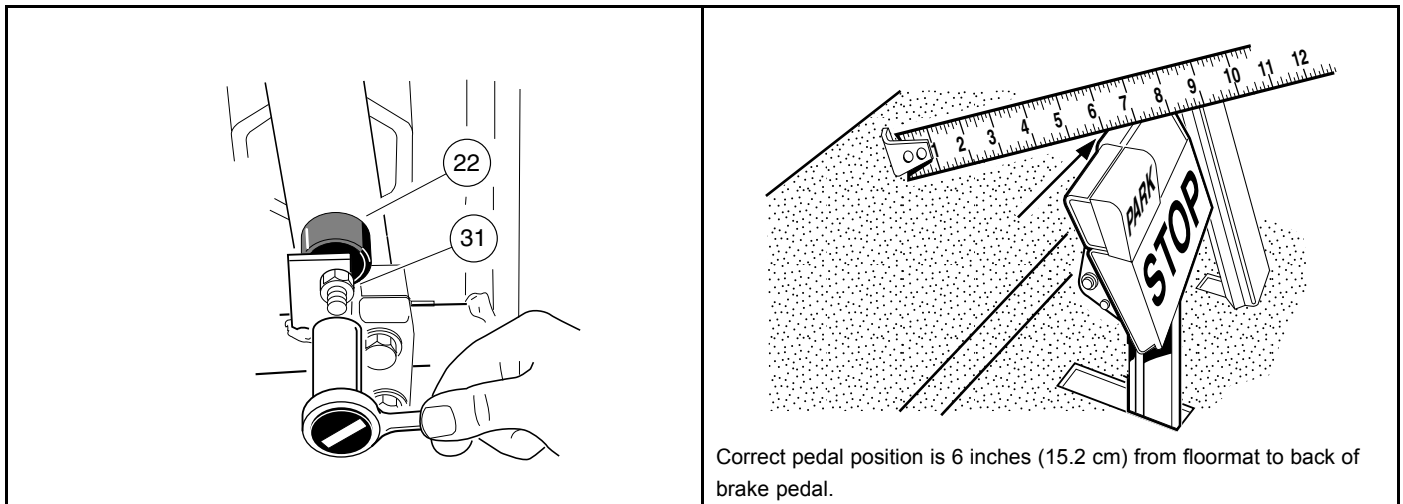

1400-18000-10211

Figure 5-20 Brake Pedal Height Adjustment

1400-18000-10212

Figure 5-21 Brake Pedal Height Measurement

3. Adjust brake pedal free play. **See following NOTE.**

NOTE: Brake pedal free play is the distance the brake pedal can be pressed before the brake actuator arm (at the brake cluster) moves.

- 3.1. Measure perpendicularly from the floorboard to the back of the brake pedal, then press the brake pedal and measure the distance that the pedal moves before all of the slack is taken out of the brake cables (**Figure 5-21, Page 5-17**).
- 3.2. Tighten the nut (2) on the equalizer rod (1) so that the brake pedal free play is 1/4 inch to 1/2 inch (6.3 mm to 12.7 mm) (**Figure 5-3, Page 5-3**).
- 3.3. Tighten the jam nut (3) while holding the adjustment nut (2) in the correct position.
4. Adjust park brake ratchet/pawl gap and pawl engagement.
 - 4.1. Inspect the park brake pawl (1) and ratchet (2) for excessive wear, grooves, cracks, or chips (**Figure 5-22, Page 5-18**). If either the pawl or ratchet is damaged, both must be replaced.
 - 4.2. Adjust retaining nut (3) on spring support rod until there is a 0.060 inch (1.5 mm) gap between the pawl and the tips of the ratchet teeth. Use a feeler gauge to verify the gap (**Figure 5-22, Page 5-18**). The gap should be consistent through range of pawl movement. If the gap is not consistent, loosen the four bolts (4) securing the accelerator pivot rod supports and adjust the supports. If the gap becomes smaller as the park brake pedal is pressed, move the pivot rod supports slightly rearward until the gap is consistent. If the gap becomes larger as the park brake pedal is pressed, move the pivot rod supports slightly forward until gap is consistent.

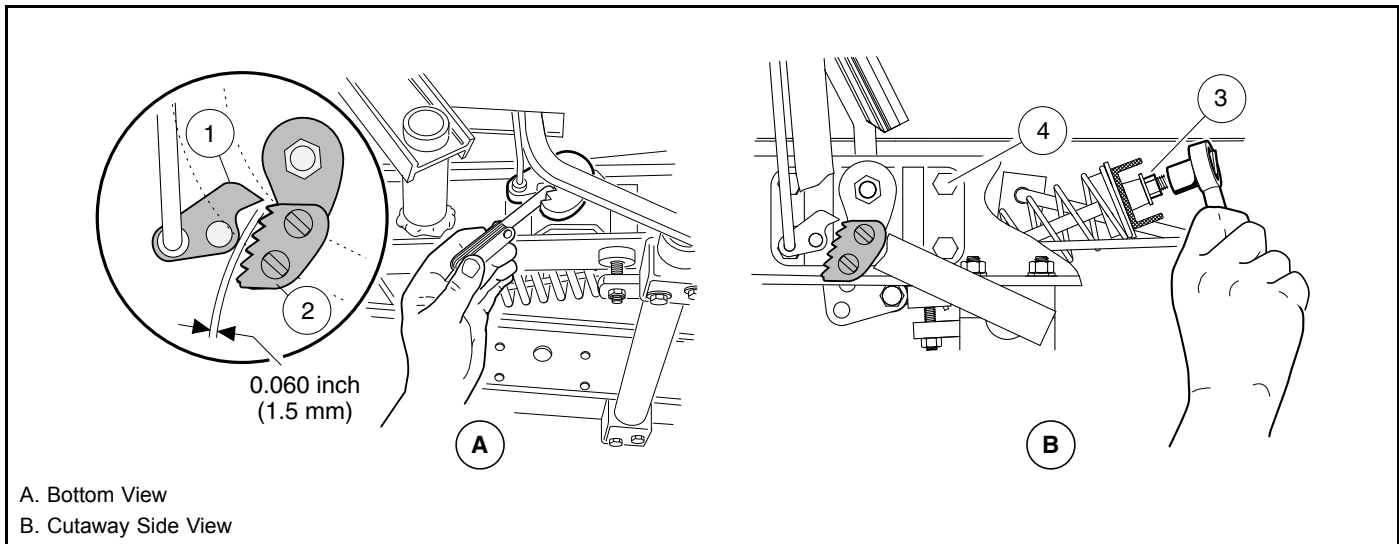

2643

Figure 5-22 Park Brake Ratchet/Pawl Gap Adjustment

- 4.3. With the park brake unlocked, measure and note the distance from the top of the accelerator pedal to the floorboard, then lock the park brake (**Figure 5-23, Page 5-18**).
- 4.4. With the park brake locked, make sure at least 75% of ratchet tooth length engages the pawl (**Figure 5-24, Page 5-18**). Tooth engagement should be between the two lines marked on the pawl.

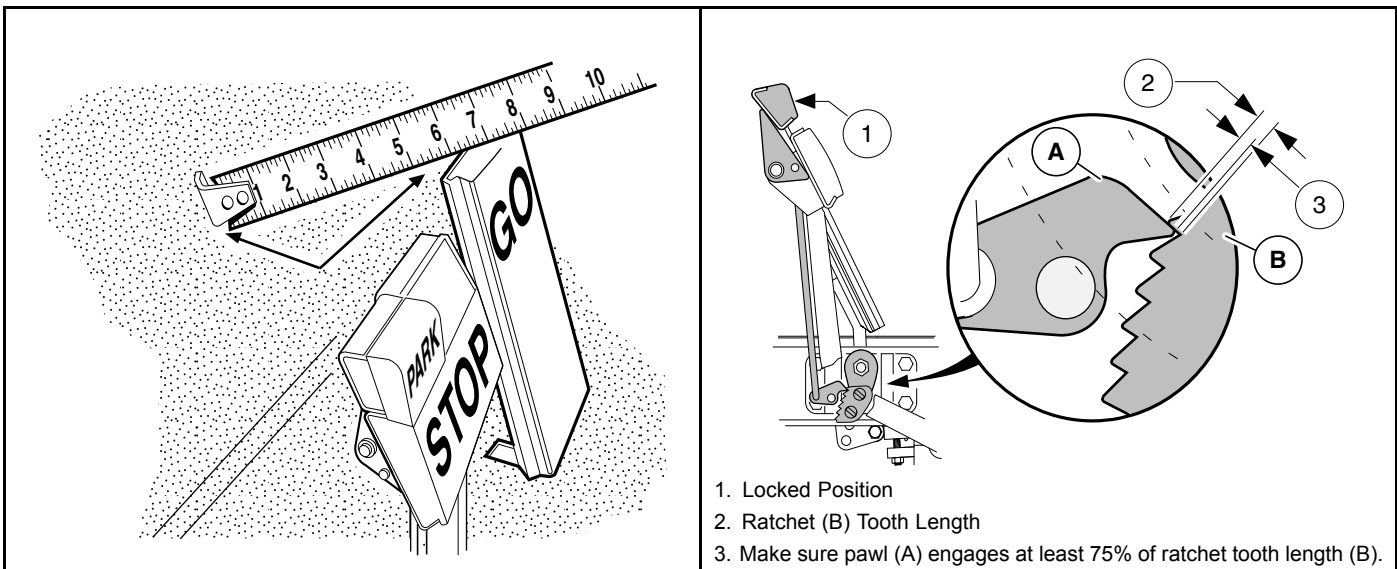

Figure 5-23 Accelerator Pedal Height Measurement

Figure 5-24 Ratchet/Pawl Tooth Engagement

- 4.5. With park brake still locked, measure the distance from the top of accelerator pedal to floorboard. If the measurement has changed, ratchet tooth engagement is too deep and must be adjusted.
- 4.6. If ratchet/pawl engagement must be adjusted, disconnect the ball joint at the top of the brake rod and rotate the ball joint sleeve clockwise to increase engagement or counterclockwise to decrease engagement. Reconnect ball joint (**Figure 5-25, Page 5-19**).
- 4.7. Check for proper brake operation prior to driving the vehicle.
5. Adjust accelerator pedal height.
 - 5.1. Loosen the nut and bolt (**Figure 5-26, Page 5-19**) securing the accelerator pedal to the pivot plate. Clamp the accelerator pedal adjustment tool (CC P/N 101871001) to the accelerator pedal, with the end marked

accelerator pedal height closest to the floorboard. Press the accelerator pedal until the end of the tool rests against the floorboard; pedal height should be 5-5/8 inches (14.3 cm). Use a rubber strap to hold pedal in position against the floorboard and then tighten nut to 26 ft·lb (35.3 N·m) (**Figure 5-27, Page 5-19**).

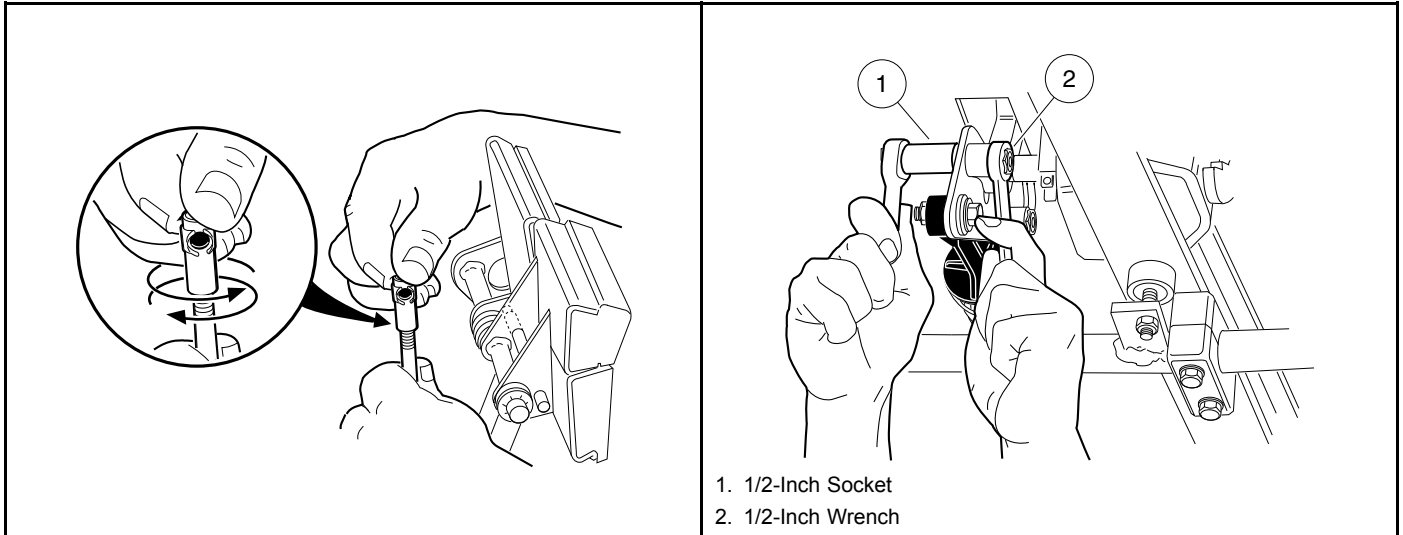

Figure 5-25 Brake Rod Adjustment

Figure 5-26 Accelerator Pedal Height Adjustment

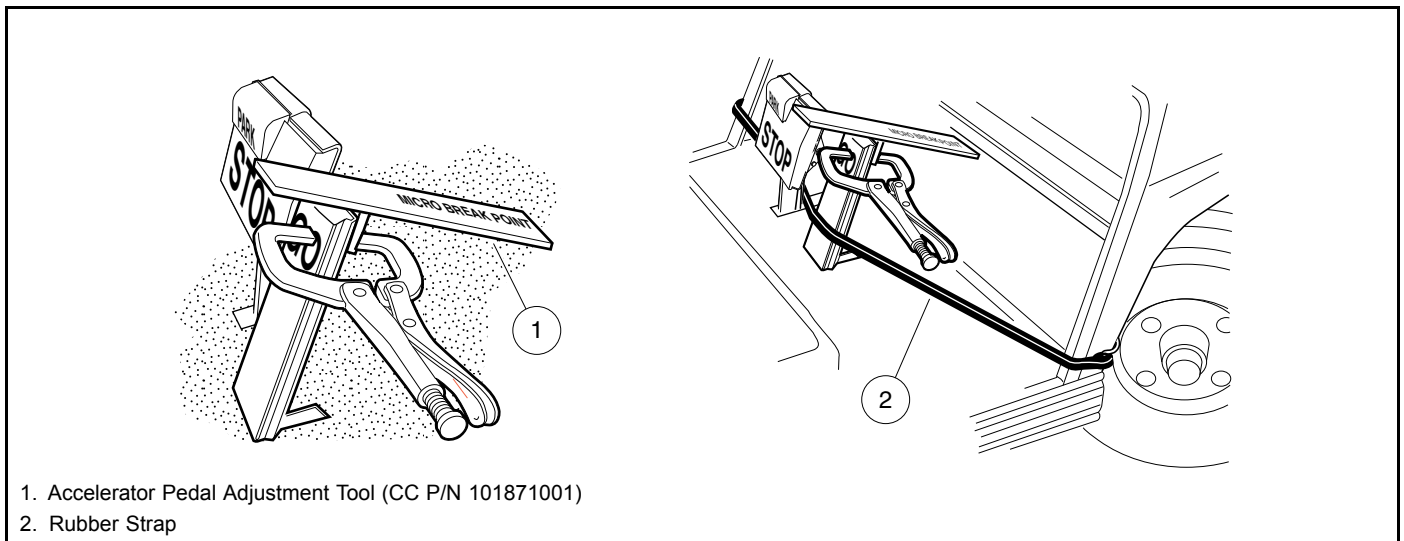

Figure 5-27 Accelerator Pedal Height Adjustment

6. Adjust the brakes. **See Brake Adjustment, Section 6, Page 6-6.**
7. Connect the battery cables. **See Connecting the Batteries – Electric Vehicles, Section 1, Page 1-4.**

Pagination Page

⚠ DANGER

- See General Warnings on page 1-1.

⚠ WARNING

- See General Warnings on page 1-1.

Asbestos Dust Warning

- Some aftermarket brake shoes contain asbestos fiber, and asbestos dust is created when these brake mechanisms are handled. Wear approved eye and respiratory protection when disassembling and cleaning brake mechanisms. Inhalation of asbestos could result in severe personal injury or death. Do not use compressed air or aerosol sprays to clean the brake mechanism. Clean brake mechanism using the negative pressure enclosure/hepa vacuum system or low pressure/wet cleaning method per OSHA/29 CFR - 1910.1001.

GENERAL INFORMATION

The vehicles covered in this manual are equipped with a mechanical brake cable system to manually-adjusted drum brakes on all four wheels. **See Section 2 – Vehicle Specifications.**

BRAKE SHOE REMOVAL

See General Warnings on page 1-1. See also Asbestos Dust Warning on page 6-1.

1. To remove rear brake shoes, place chocks at the front wheels, loosen the rear wheel lug nuts, and lift the rear of the vehicle with a chain hoist or floor jack. Place jack stands under the axle tubes to support the vehicle.
2. Release park brake if latched and loosen equalizer retaining nuts (1) on equalizer rod (2) to slightly loosen brake cable (**Figure 6-1, Page 6-2**).
3. Remove the rear wheels and brake drums. If the brake drums were easily removed, proceed to remove axle (for electric vehicles only) or remove wheel hub (for gasoline vehicles only). **See following CAUTION and NOTE.**

⚠ CAUTION

- Worn or damaged brake drums cannot be machined to refinish them. Replace as necessary.
4. Removing brake drums with badly worn brake shoes.
 - 4.1. On the back of each brake cluster assembly, locate the heads of two brake shoe retainer pins. It may be necessary to remove sealant material around the head of each pin.

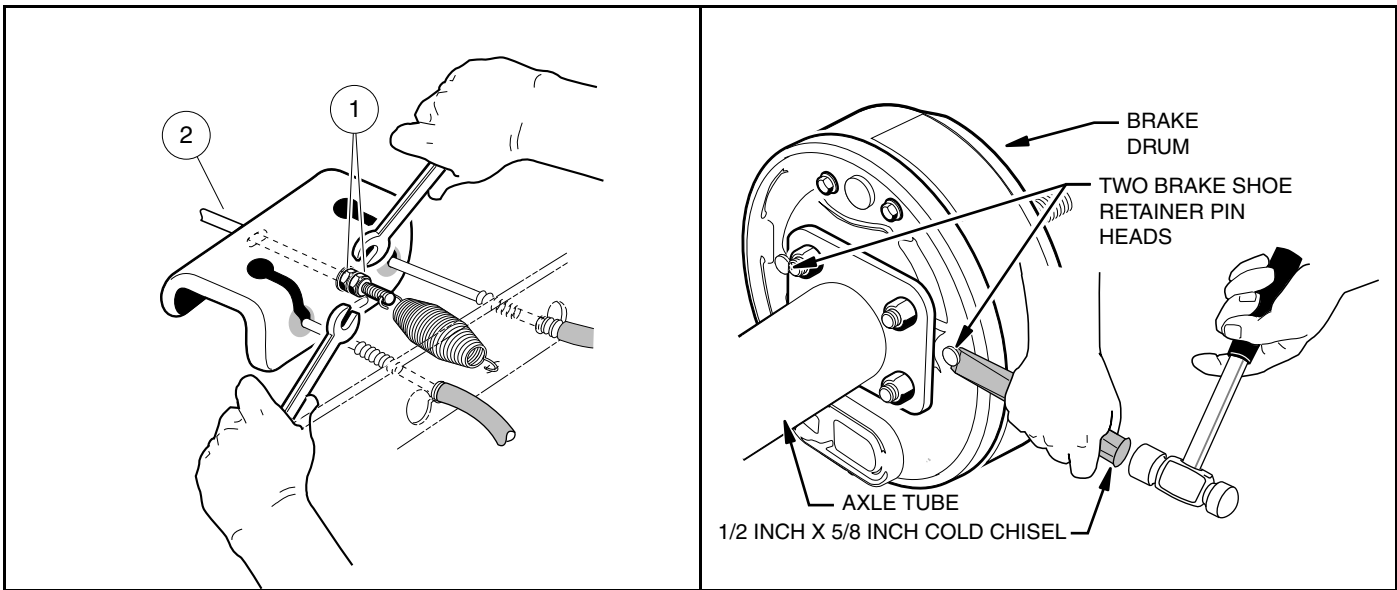

2814

Figure 6-1 Loosen Equalizer Nut

2834a

Figure 6-2 Shoe Retainer Pins

- 4.2. Insert a 1/2 inch x 5/8 inch cold chisel (1) under the head (2) of each pin and shear them off as illustrated (**Figure 6-2, Page 6-2**). This will release the shoes from the backing plate, allowing them to pivot away from the inside of the brake drum (3), which should then allow the brake drum to be pulled free. After completing step 6, skip step 7. **See following NOTE.**

NOTE: Although step 6 allows easier access to the brake shoes, it is not imperative to do so in order to remove the brake shoes.

5. **For electric vehicles:** Remove the axle shaft. **See Axle Shaft and Oil Seal Removal, Section 17, Page 17-1.**
For gasoline vehicles: Remove the wheel hub assembly. **See Rear Hub Removal, Section 26, Page 26-4.**
6. Using needle nose pliers, turn the clip retainer pin (1) 90° to remove the shoe retainer clip (2). **See following CAUTION.**

CAUTION

- The brake shoes are under spring pressure and can release suddenly when brake shoe retainers are removed.
7. Grasp both brake shoes and pull them, together with the springs, out of the brake assembly as shown.

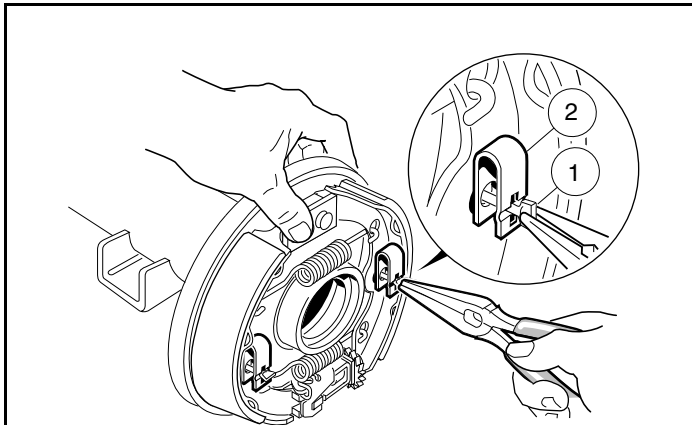

2824

Figure 6-3 Rotate Clip Retainer

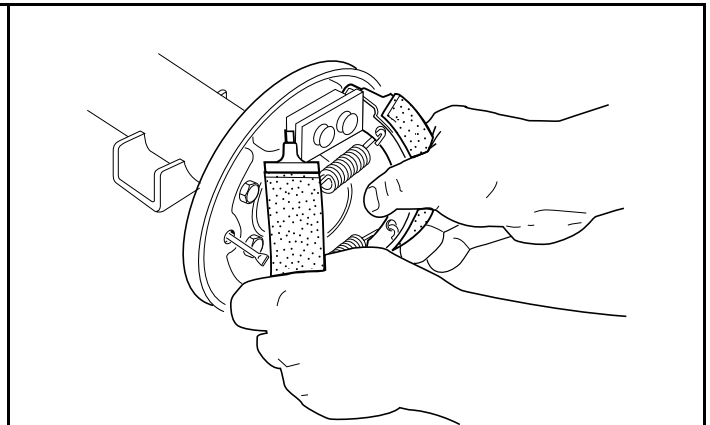

2825

Figure 6-4 Remove Shoes

BRAKE ASSEMBLY CLEANING

See General Warnings on page 1-1. See also Asbestos Dust Warning on page 6-1.

- Carefully clean the brake backing plate and all mechanical components.
- Remove the rubber boot from backing plate and wipe with a clean damp cloth.

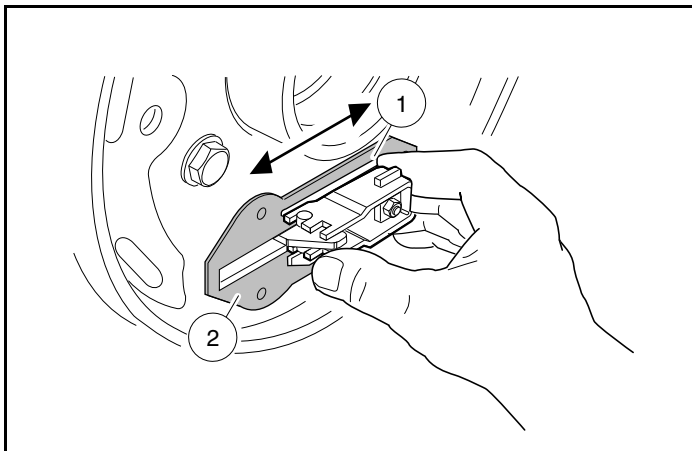

2816

Figure 6-5 Lubricate Slide

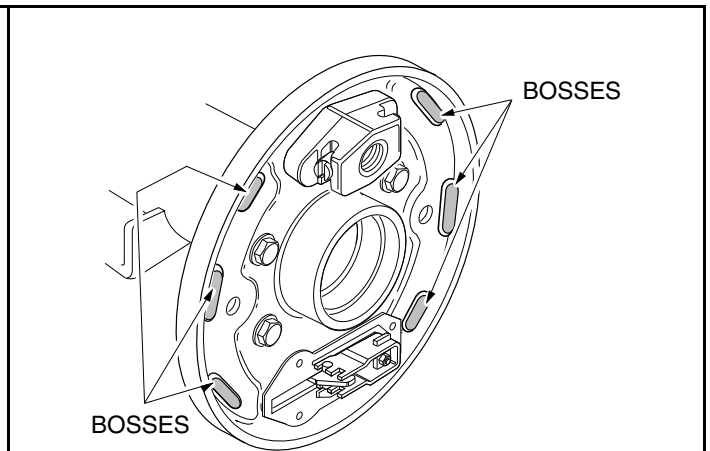

2817

Figure 6-6 Lubricate Raised Bosses

- Lubricate the slide (1) and slide plate (2) with dry moly lubricant (P/N 1012151) on both sides of the backing plate. After lubricating, work slide back and forth against backing plate to ensure that it slides smoothly and easily (Figure 6-5, Page 6-3). Install rubber boot onto backing plate. Reinstall rubber boot onto backing plate. See following WARNING

⚠ WARNING

- Apply grease carefully when performing the following steps. Do not allow any grease to get onto the friction surfaces of the brake shoe pads or the brake drum. Failure to heed this warning could cause diminished brake performance, possibly resulting in property damage or severe personal injury.

4. Use a small brush to carefully apply a light coat of white lithium NLGI #2 grease (Dow Corning® BR2-Plus or equivalent) on each of the six raised bosses on brake backing plate (**Figure 6-7, Page 6-4**). **See preceding WARNING.**
5. Use a small brush to carefully apply a light coat of white lithium NLGI #2 grease (Dow Corning BR2-Plus or equivalent) to each end of both brake shoes and into the slots in the brake shoe mounting block as shown (**Figure 6-10, Page 6-4**). **See preceding WARNING.**

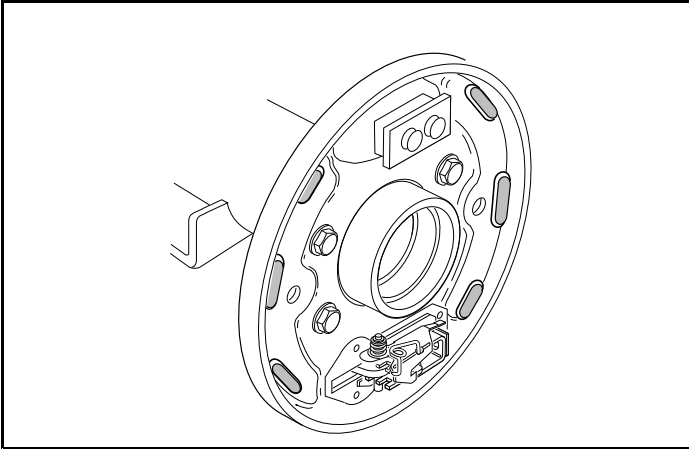

640

Figure 6-7 Lubricate Bosses

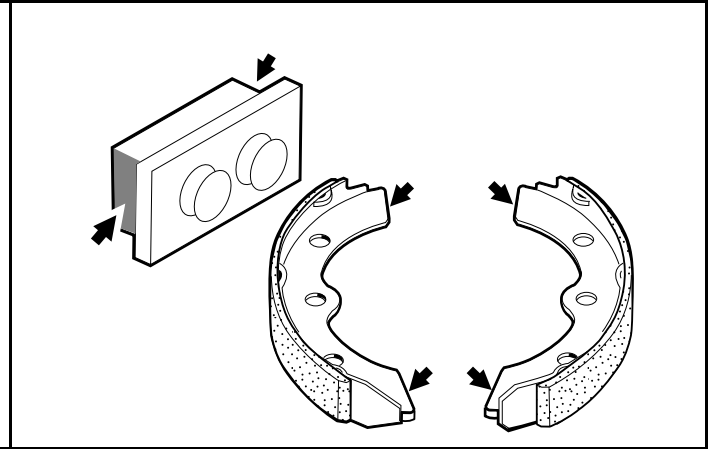

641

Figure 6-8 Lubricate Brake Shoes and Slots

6. Use a small brush to carefully apply a light coat of white lithium NLGI #2 grease (Dow Corning BR2-Plus or equivalent) to the brake actuator assembly as shown (**Figure 6-9, Page 6-4**). **See preceding WARNING.**

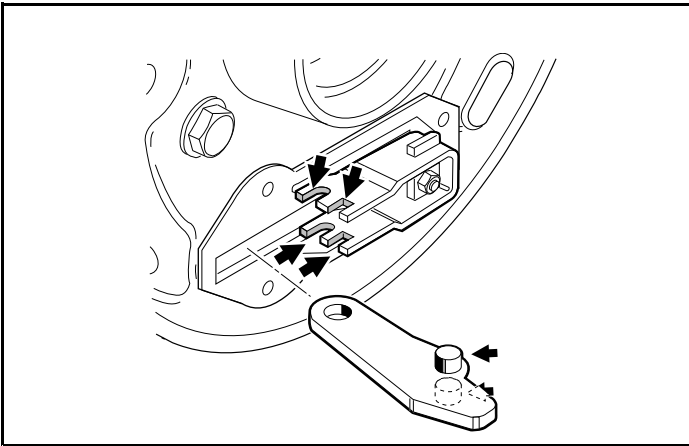

2799

Figure 6-9 Lubricate Actuator

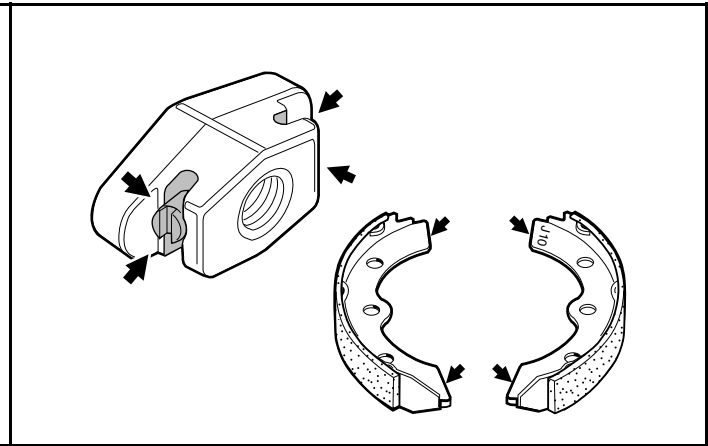

2819

Figure 6-10 Lubricate Shoes

BRAKE SHOE INSTALLATION

See General Warnings on page 1-1. See also Asbestos Dust Warning on page 6-1.

NOTE: Components of the front wheel brake assembly are identical to the rear wheel manually-adjusted brake assembly. The front brake assembly is rotated 90° (when compared to the rear brake assembly) so the adjusting bolt on each assembly is oriented to the rear of the vehicle rather than at the top of the assembly (Figure 6-23, Page 6-14).

1. Position one shoe in the slots in the mounting block anchor piston and brake actuator (Figure 6-14, Page 6-6). See following WARNING.

▲ WARNING

- When installing brake shoes, the shoes must be oriented with tips stamped J10 inserted into the mounting block anchor piston slots rather than into the brake actuator slots (Figure 6-14, Page 6-6). Incorrectly installed brake shoes will be too tight and make adjustment of the brake impossible.
2. Install the shoe retainer clip, using pliers to compress the clip (1) while turning the retainer pin (2) into position (Figure 6-12, Page 6-5).
 3. Attach the springs (with hooks pointing outwards) onto the trailing shoe already installed. Then hold the leading shoe next to the trailing shoe, correctly oriented, and attach the springs to it (Figure 6-13, Page 6-6).

NOTE: With brake shoe tips marked J10 oriented to the mounting block, the stamping will be visible on one shoe only. The other J10 stamping will be facing the backing plate and will not be visible.

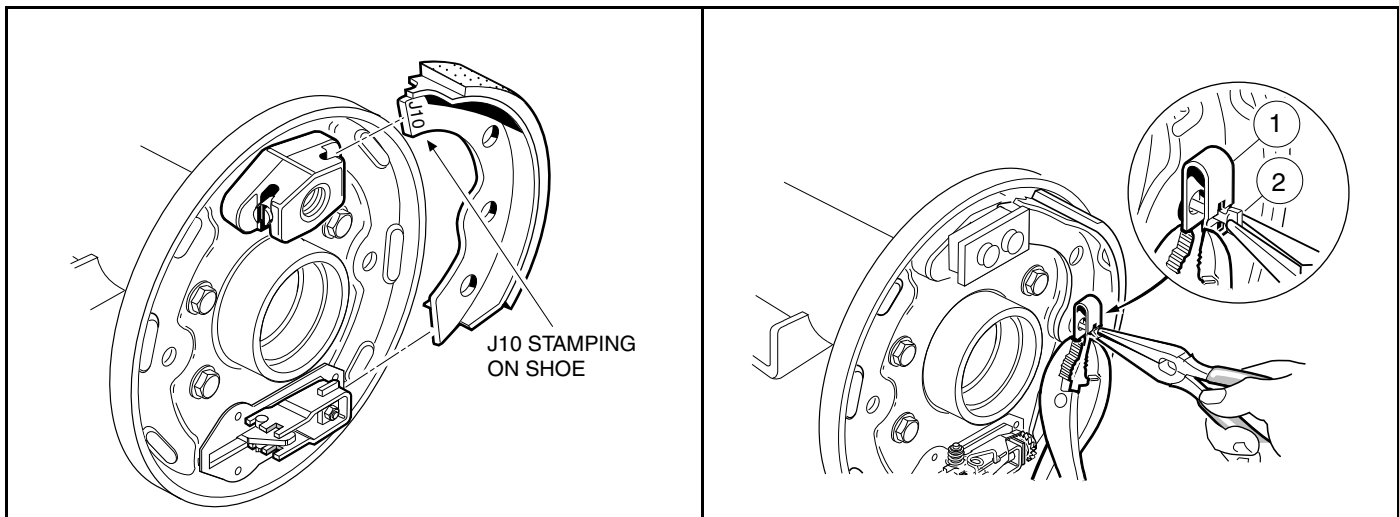

2807

Figure 6-11 Position Shoes

644

Figure 6-12 Retainer Clip

4. While maintaining spring attachment on both shoes, position tips of the second shoe (1) in the mounting slots and then push shoe into place. Hold shoe in position and install retaining clip.
5. After the shoes are installed, move them together up and down and side to side to make sure that they will easily slide approximately 1/4 inch to 3/8 inch (6.3 mm to 9.5 mm) without binding. Make sure the shoes are positioned vertically so the tips of the shoes are positioned flush with the top surface of the shoe mounting blocks as shown in (Figure 6-13, Page 6-6). See following CAUTION.

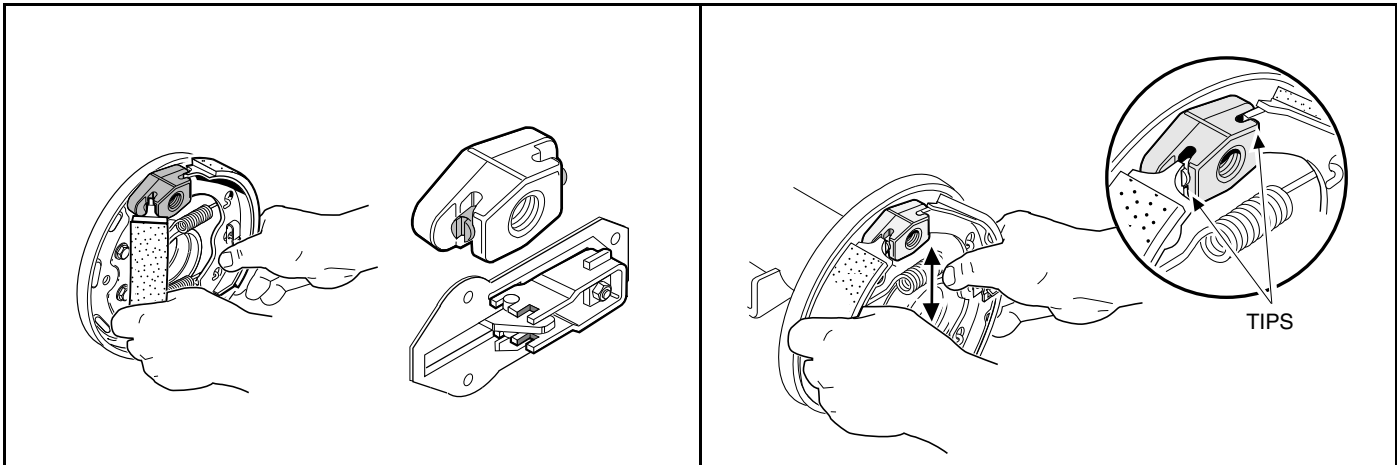

2808

Figure 6-13 Insert Shoes

2800

Figure 6-14 Position Shoes

CAUTION

- Clean any residual oil from the exposed end of the axle shaft and from the oil seal area prior to installing the axle shaft.
6. For electric vehicles: Install the axle shaft. See Axle Shaft and Oil Seal Installation, Section 17, Page 17-4.
For gasoline vehicles: Install the wheel hub assembly. See Rear Hub Installation, Section 26, Page 26-4.
 7. Install the brake drum and make sure that it is properly seated. See following NOTE.
- NOTE:** If drum installation is difficult, the brake shoes may need to be adjusted vertically in the mounting slots.
8. After the drum is installed, make sure the axle and drum turn freely.

BRAKE ADJUSTMENT

See General Warnings on page 1-1. See also Asbestos Dust Warning on page 6-1.

CAUTION

- Pedal group adjustment must be within specifications prior to beginning brake adjustment. Perform the appropriate pedal group adjustment.
- For gasoline vehicles, refer to Pedal Group Adjustment – Gasoline Vehicles on page 5-10.
- For electric vehicles, refer to Pedal Group Adjustment – Electric Vehicles on page 5-16.

NOTE: All brake cluster components must be clean, lubricated, and in good working condition prior to beginning brake adjustment.

All wheels must be installed on the vehicle and lug nuts tightened to 65 ft·lb (88 N·m).

BRAKE CLUSTER ADJUSTMENT

1. Chock the wheels.
2. To provide slack in the brake cables, loosen the equalizer retaining nuts (1 and 5) on the equalizer rod (2) (**Figure 6-15, Page 6-7**).
3. Loosen the front brake equalizer rod (**Figure 6-16, Page 6-7**).

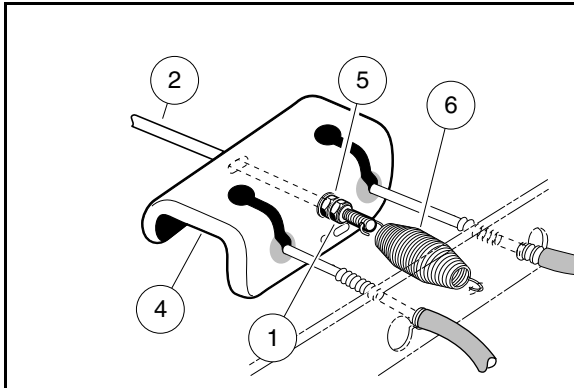

2801

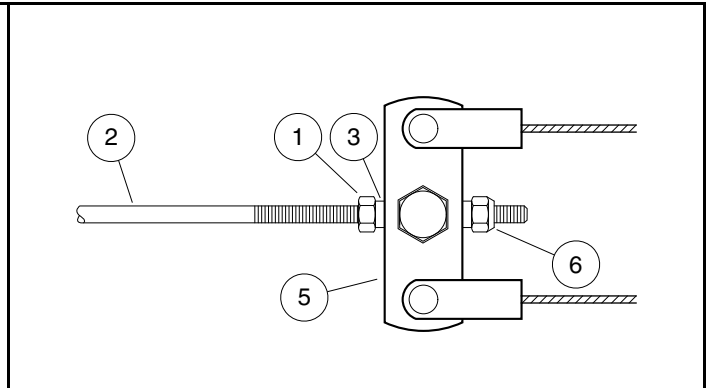
Figure 6-15 Rear Equalizer Adjustment

2802

Figure 6-16 Front Equalizer Adjustment

4. Remove the dust cover (4) on the left and right rear brake cluster assemblies (**Figure 6-17, Page 6-7**).

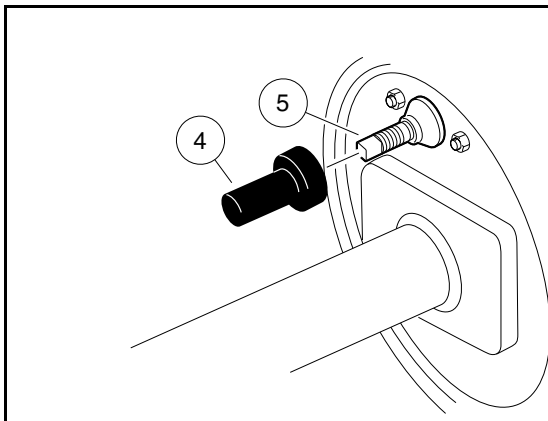

2804

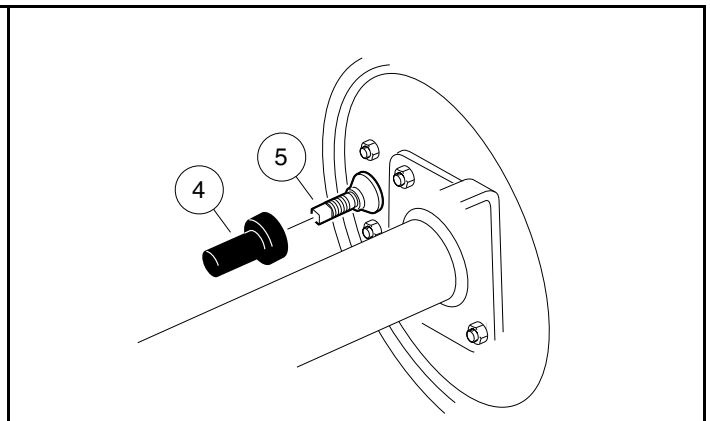
Figure 6-17 Rear Brake Adjustment Bolt

2803

Figure 6-18 Front Brake Adjustment Bolt

5. Use a torque wrench and a 7 mm 8-point socket or Club Car brake adjustment tool (CC P/N 1013582) to turn the brake adjustment bolt (5) on each brake clockwise until it is tightened to 15 ft·lb (20.3 N·m) then back off 5 clicks. **See following NOTE**

NOTE: If a wheel can still be turned by hand after step 4, inspect the brake clusters and clean and/or replace all parts that do not work properly.

6. Repeat procedure at front brake clusters.

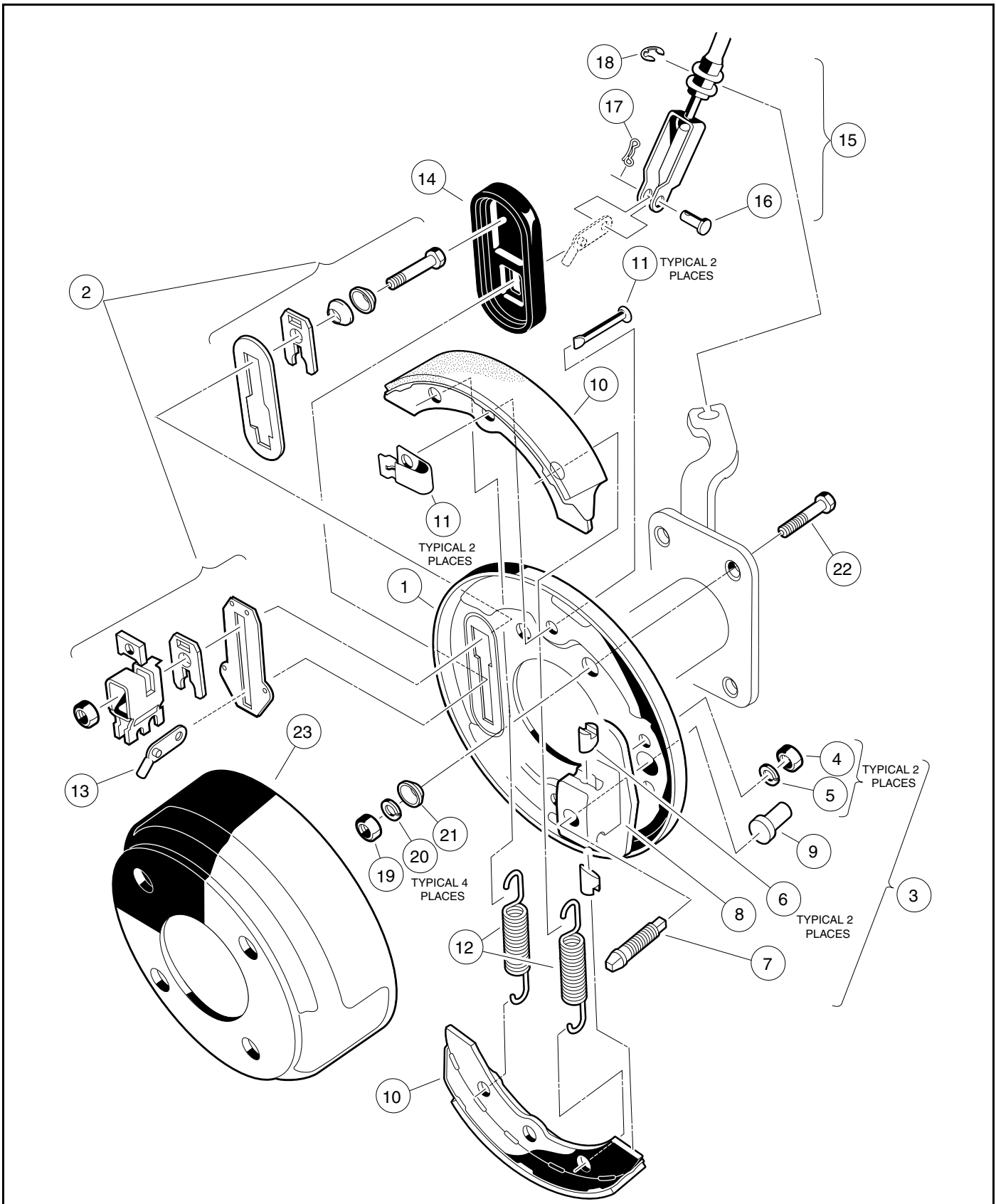

2806

Figure 6-19 Front Manually Adjusted Brake Assembly

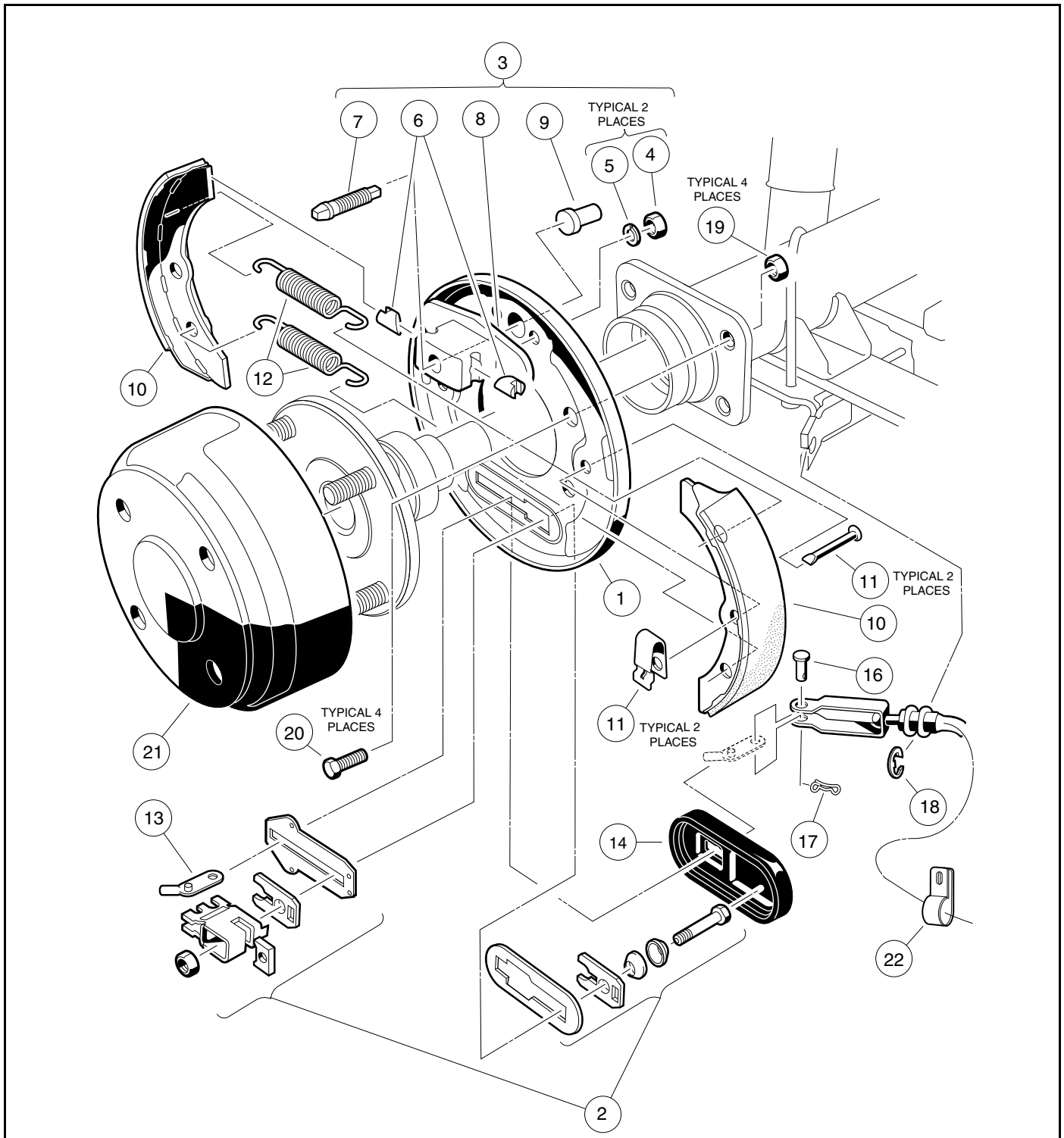

2903

Figure 6-20 Rear Manually-Adjusted Brake Assembly

BRAKE CABLE EQUALIZATION

1. Set park brake in the third tooth of the ratchet. Place a wedge between the park brake pedal and brake pedal to prevent the park brake from disengaging while equalizing the brake cables (**Figure 6-21, Page 6-10**).

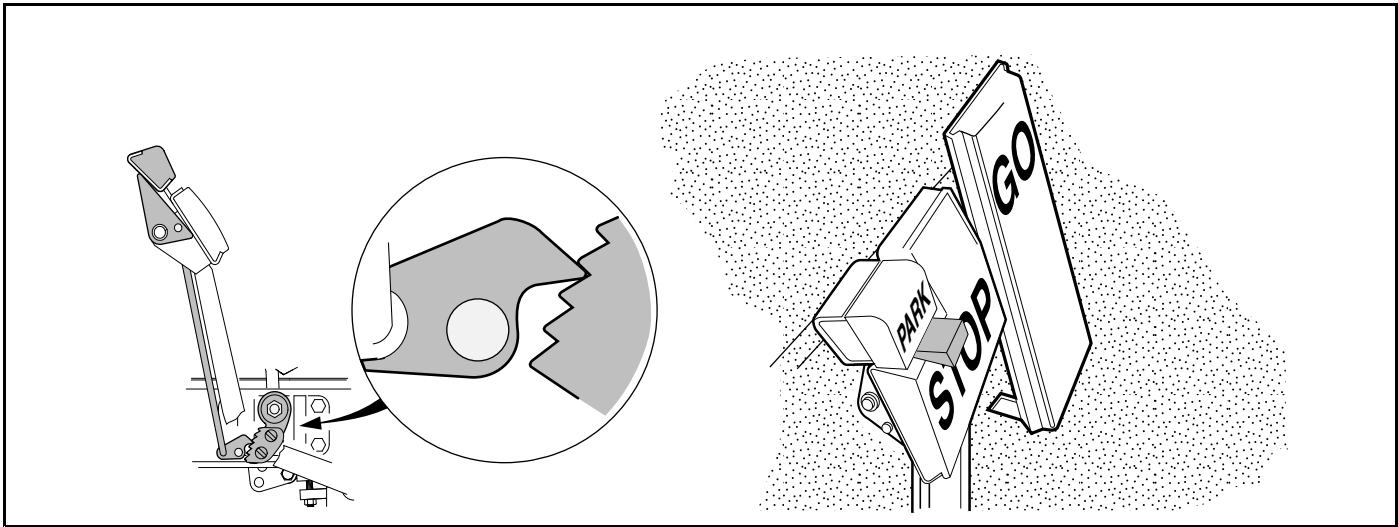

2809

Figure 6-21 Set Park Brake and Insert Wedge

2. Equalize the brake cables.
 - 2.1. Tighten the nylon lock nut (6) on the front equalizer rod (2) to 35 in·lb (4 N·m) (Figure 6-16, Page 6-7).
 - 2.2. Tighten the jam nut (5) on the rear equalizer rod (2) clockwise to 35 in·lb (4 N·m) (Figure 6-15, Page 6-7).
 - 2.3. Repeat steps 3 and 4 until the nuts remain on the torque setting.
 - 2.4. Hold the lock nut (6) on the front equalizer rod (2) in place with a wrench and tighten the jam nut (1) to 13 ft·lb (17.6 N·m) (Figure 6-16, Page 6-7).
 - 2.5. Hold the jam nut (5) on the rear equalizer rod (2) in place with a wrench and tighten the lock nut (1) to 13 ft·lb (17.6 N·m) (Figure 6-15, Page 6-7). See following CAUTION.

CAUTION

- If the brake pedal return spring (6) was disconnected while equalizing the brake cables, be sure to reconnect it before proceeding (Figure 6-15, Page 6-7).

FINAL BRAKE CLUSTER ADJUSTMENT

1. To adjust the brake shoes, turn the adjustment bolt counterclockwise five clicks.
2. Repeat step 1 at other brake cluster(s).
3. Install the rubber dust covers (4) over the brake adjustment bolts (5) (Figure 6-17, Page 6-7) and (Figure 6-18, Page 6-7).
4. Carefully support the vehicle with the lifting device, remove jack stands and lower the vehicle to the ground.

TEST DRIVE VEHICLE

1. With the vehicle on a level surface, release the park brake and push the vehicle by hand. If brake drag exists, readjust cable tension and brakes. See Brake Cable Equalization on page 6-9. See Final Brake Cluster Adjustment on page 6-10.
2. Pedal free play should be less than 1 inch (2.5 cm). If free play exceeds 1 inch (2.5 cm), check pedal group adjustment, and readjust cable tension and brakes. See Brake Cable Equalization on page 6-9. See Final Brake Cluster Adjustment on page 6-10. See following NOTE.

NOTE: Brake pedal free play is the distance the brake pedal can be pressed before the brake actuator arm (at the brake cluster) moves.

3. Test drive vehicle. Be sure the brakes function properly. When brake pedal is fully pressed under moderate pressure, it should not go more than halfway to floor, and the vehicle should come to a smooth, straight stop. If the brake pedal goes more than halfway to the floor, or if the vehicle swerves or fails to stop, check pedal group adjustment, and readjust cable tension and brakes. **See Brake Cable Equalization on page 6-9. See Final Brake Cluster Adjustment on page 6-10.** Brake adjustment must be maintained so the brake pedal cannot be pressed to the floor under any circumstance.

BRAKE CLUSTER REMOVAL AND INSTALLATION

See General Warnings on page 1-1. See also Asbestos Dust Warning on page 6-1.

FRONT BRAKE CLUSTER REMOVAL

1. Place chocks at rear wheels, loosen lug nuts on front wheels, and lift the front of the vehicle with a chain hoist or floor jack. Place jack stands under the round tube crossmember of the frame to support vehicle.
2. Release park brake.
3. Loosen the equalizer retaining nuts (1 and 6) on the front equalizer rod (2) to slightly loosen the brake cable (**Figure 6-16, Page 6-7**).
4. Remove the front wheels and then the brake drums.
5. Remove bow-tie pin (17) and clevis pin (16) from brake cable (**Figure 6-23, Page 6-14**) (**Figure 6-22, Page 6-12**).
6. Remove dust cap (6) on hub and bearing assembly.
7. Remove cotter pin (5) and hex nut (7) from spindle shaft (**Figure 6-22, Page 6-12**).
8. Remove hub and bearing assembly from spindle shaft. Remove four bolts (22), cone washers (21), lockwashers (20), and hex nuts (19) that mount the brake cluster to the spindle (**Figure 6-23, Page 6-14**).
9. Remove brake cluster assembly from spindle.

FRONT BRAKE CLUSTER INSTALLATION

1. Install in reverse order of removal. Use bolts (22), cone washers (21), lock washers (20), and hex nuts (19) to mount brake cluster (**Figure 6-23, Page 6-14**).
2. Tighten bolts to 30 ft·lb (41 N·m). Adjust brakes as previously described in this section. Use new bow-tie pins when reconnecting brake cables.

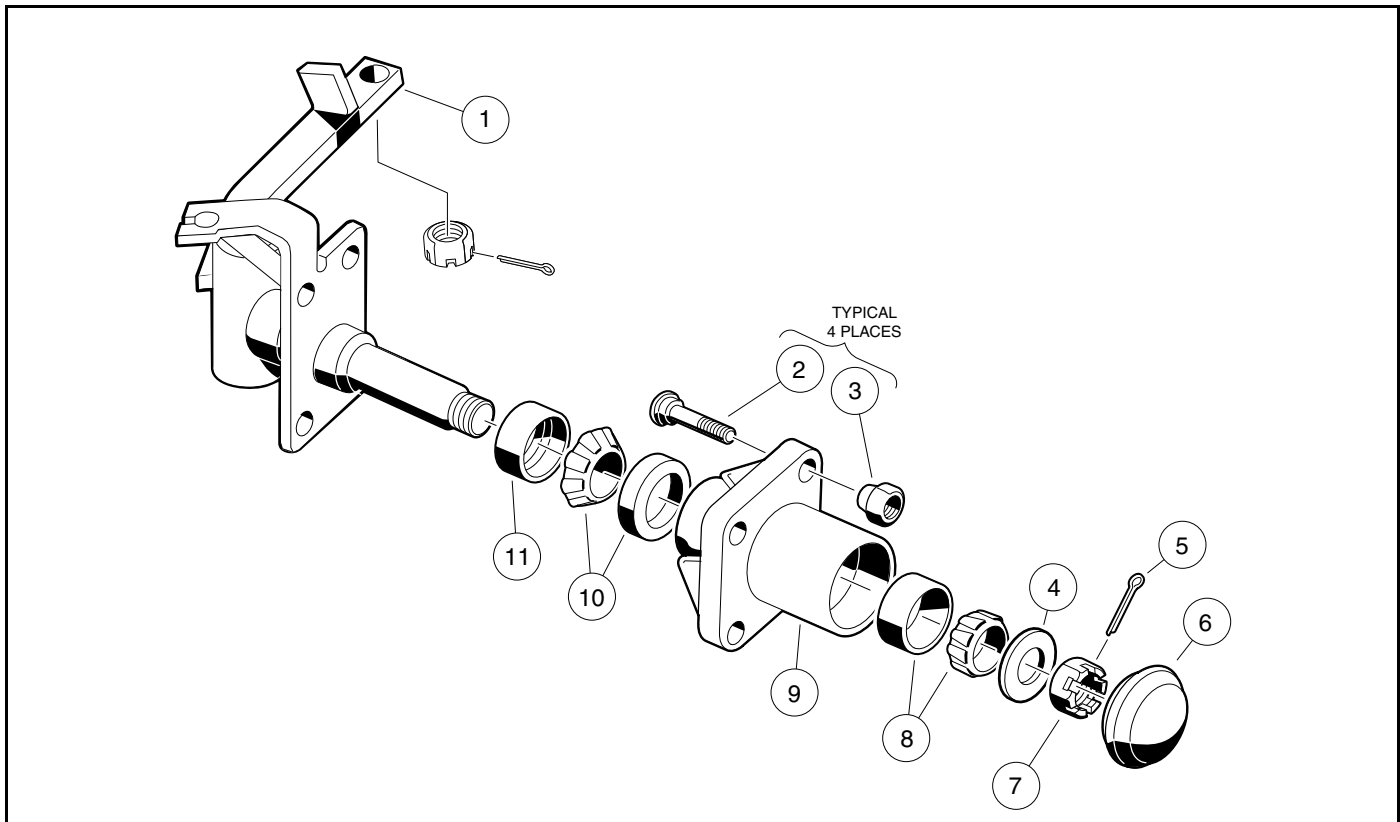

2810

Figure 6-22 Front Spindle Assembly

REAR BRAKE CLUSTER REMOVAL

1. Place chocks at the front wheels, loosen the lug nuts on the rear wheels and lift the rear of the vehicle with a chain hoist or floor jack. Place jack stands under the axle tubes to support the vehicle.
2. Release park brake and loosen equalizer retaining nuts (1 and 5) on equalizer rod (2) to slightly loosen brake cable (**Figure 6-15, Page 6-7**).
3. Remove the rear wheels and then the brake drums. **See following NOTE.**

NOTE: When servicing vehicles with brake drums that cannot be removed by normal methods, perform step 4 of **Brake Shoe Removal on page 6-1**, then continue with this procedure.

4. **For electric vehicles:** Remove the axle shaft. **See Axle Shaft and Oil Seal Removal, Section 17, Page 17-1.**
For gasoline vehicles: Remove the wheel hub assembly. **See Rear Hub Removal, Section 26, Page 26-4.**
5. Remove bow-tie pin (17) and clevis pin (16) from brake cable (**Figure 6-20, Page 6-9**).
6. Remove 4 bolts (20) and cone lock nuts (19) that mount the brake cluster to the transaxle (**Figure 6-20, Page 6-9**).
7. Remove rear brake cluster assembly from transaxle.

REAR BRAKE CLUSTER INSTALLATION

1. Install in reverse order of disassembly. Use new bow tie locking pins when installing brake cables. **See following CAUTION for Electric Vehicles.**

⚠ CAUTION

- Clean any residual oil from the exposed end of the axle tube and from the oil seal area prior to installing the axle shaft.
2. Be sure bolts (20) and new lock nuts (19) are used to mount the brake cluster (**Figure 6-20, Page 6-9**).
 3. Tighten nuts to 17 ft·lb (23.0 N·m). If torquing the bolt heads, torque to 30 ft·lb (40 N·m). **See following WARNING for Electric Vehicles.**

⚠ WARNING

- Be sure retaining ring is properly seated in groove. If ring is not properly installed, axle assembly will separate from transaxle and damage axle assembly and other components. Loss of vehicle control could result in severe personal injury or death.
4. **For electric vehicles:** Install the axle shaft. **See Axle Shaft and Oil Seal Installation, Section 17, Page 17-4.**
For gasoline vehicles: Install the wheel hub assembly. **See Rear Hub Installation, Section 26, Page 26-4.**
 5. Adjust brakes as previously described in this section.

FRONT BRAKE CABLES

See General Warnings on page 1-1. See also Asbestos Dust Warning on page 6-1.

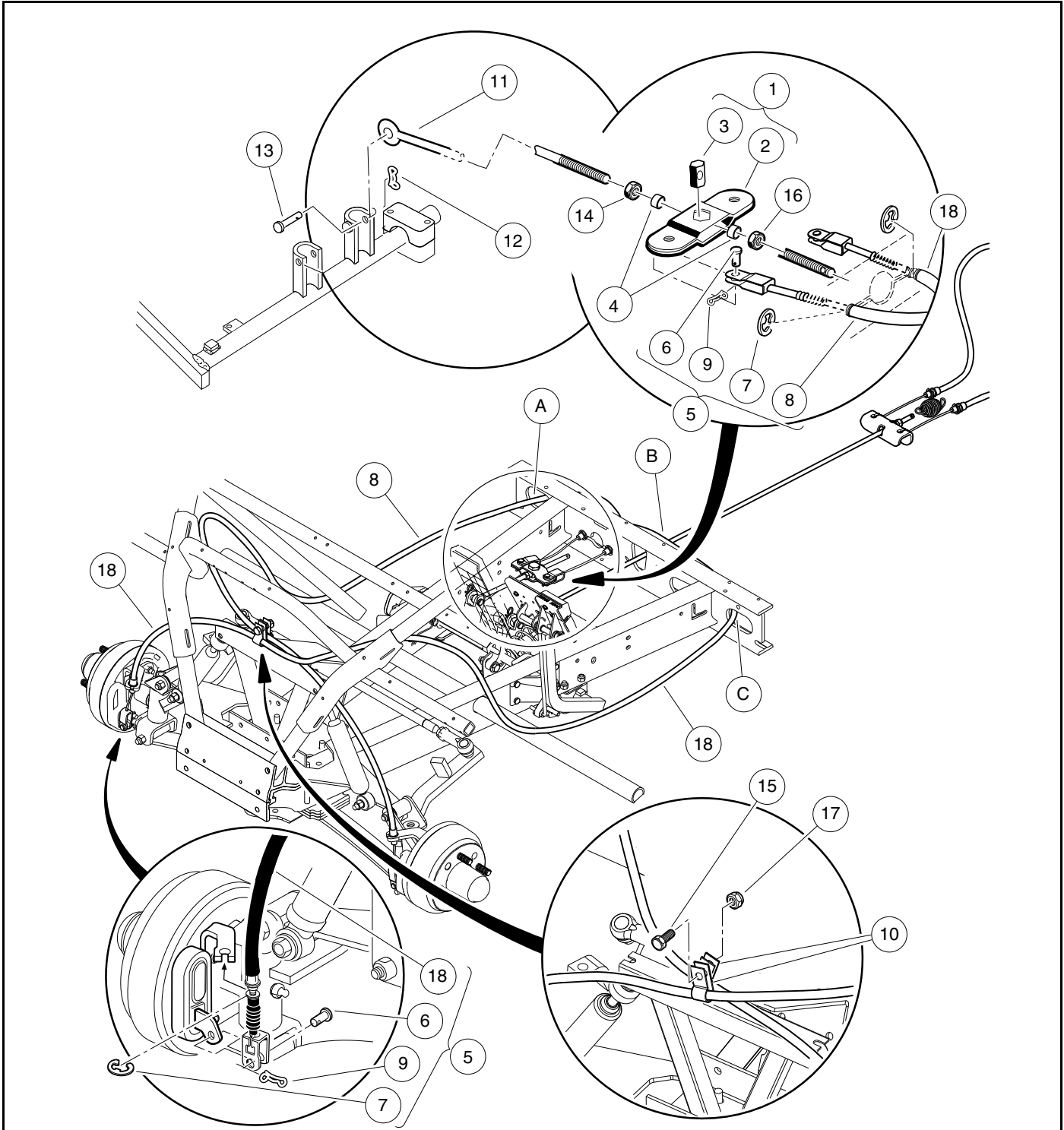

3189

Figure 6-23 Front Brake Cables and Equalizer

FRONT BRAKE CABLE REMOVAL

1. Remove bow-tie pin (9) and clevis pin (6) from brake lever arm on front brake cluster (**Figure 6-23, Page 6-14**).
2. Remove E-clip (7) from brake cable housing at the front spindle bracket and remove cable (8 or 18) from spindle.
3. Remove bow-tie pin (9), clevis pin (6), and E-clip (7) from brake cable (8 or 18) at equalizer (2).
4. Remove bolt (15) and nut (17) from brake cable clamp (10).
5. Note location and number of wire ties securing brake cable to chassis (**Figure 6-24, Page 6-15**). Cut wire ties and remove front brake cable from vehicle.

FRONT BRAKE CABLE INSTALLATION

1. Place brake cable (8 or 18) through frame mounting hole behind equalizer (2) and install E-clip (7) on cable housing (**Figure 6-23, Page 6-14**).
2. Attach brake cable clevis to equalizer (2) with clevis pin (6) and new bow-tie pin (9).
3. Route inner cable (8) through slot opening in passenger-side of I-beam (A).
4. Route outer cable (18) over rear brake equalizer rod (B) and through slot opening in driver-side of I-beam (C).
5. Route cables (8 and 18) along inside of frame rails towards front of vehicle (**Figure 6-23, Page 6-14**); through gap between floorboard and tubular crossmember; under cowl frame supports; and crisscross above shock support as shown (**Figure 6-24, Page 6-15**).
6. Secure brake cable clamp (10) with a bolt (15) and nut (17) (**Figure 6-23, Page 6-14**).
7. Attach brake cable (8 or 18) through the front spindle bracket with E-clip (7).
8. Attach brake cable clevis to brake lever arm with clevis pin (6) and a new bow-tie pin (9).
9. At original locations, secure brake cable (8 or 18) to chassis with new wire ties (**Figure 6-24, Page 6-15**).
10. Adjust brakes. **See Brake Adjustment on page 6-6.**

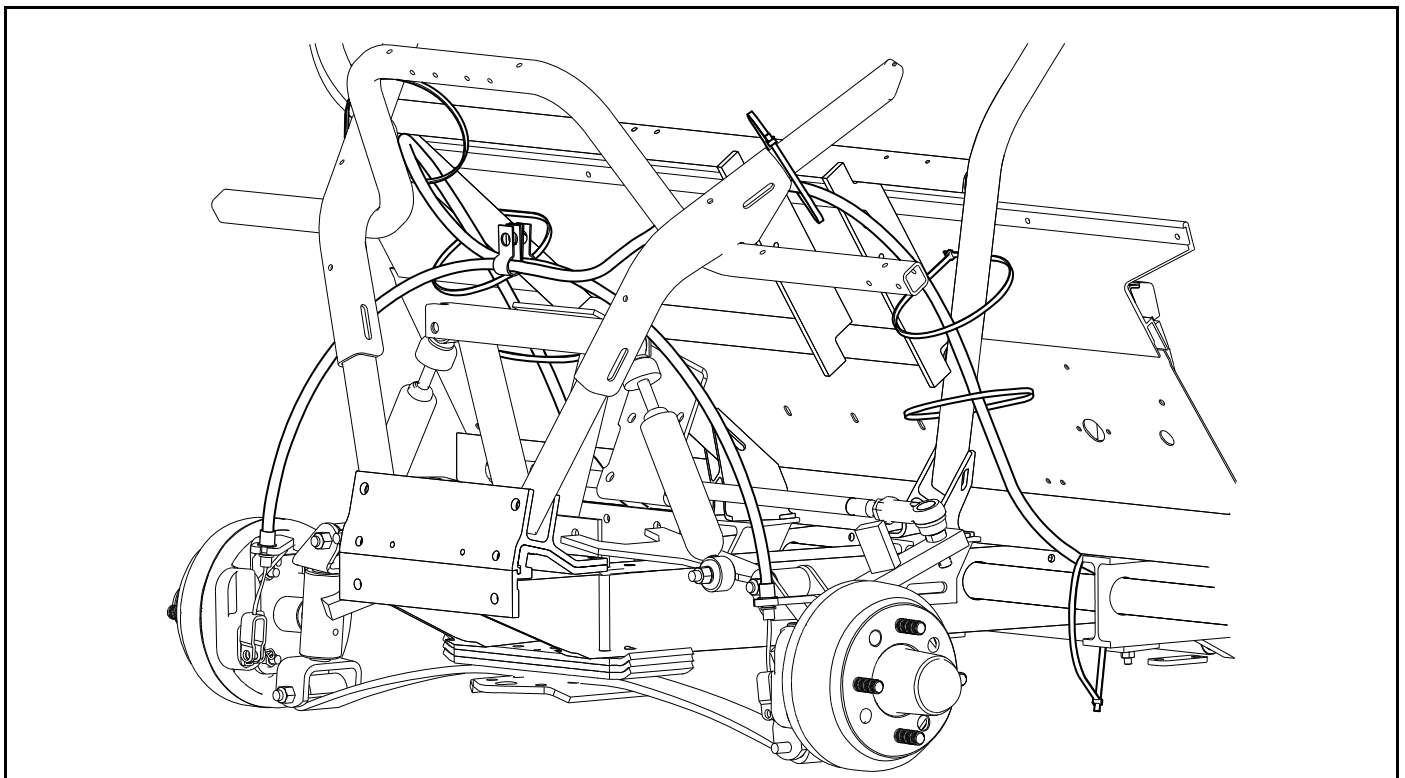

3190

Figure 6-24 Front Brake Cable Routing Under Cowl and Wire Tie Locations

REAR BRAKE CABLES

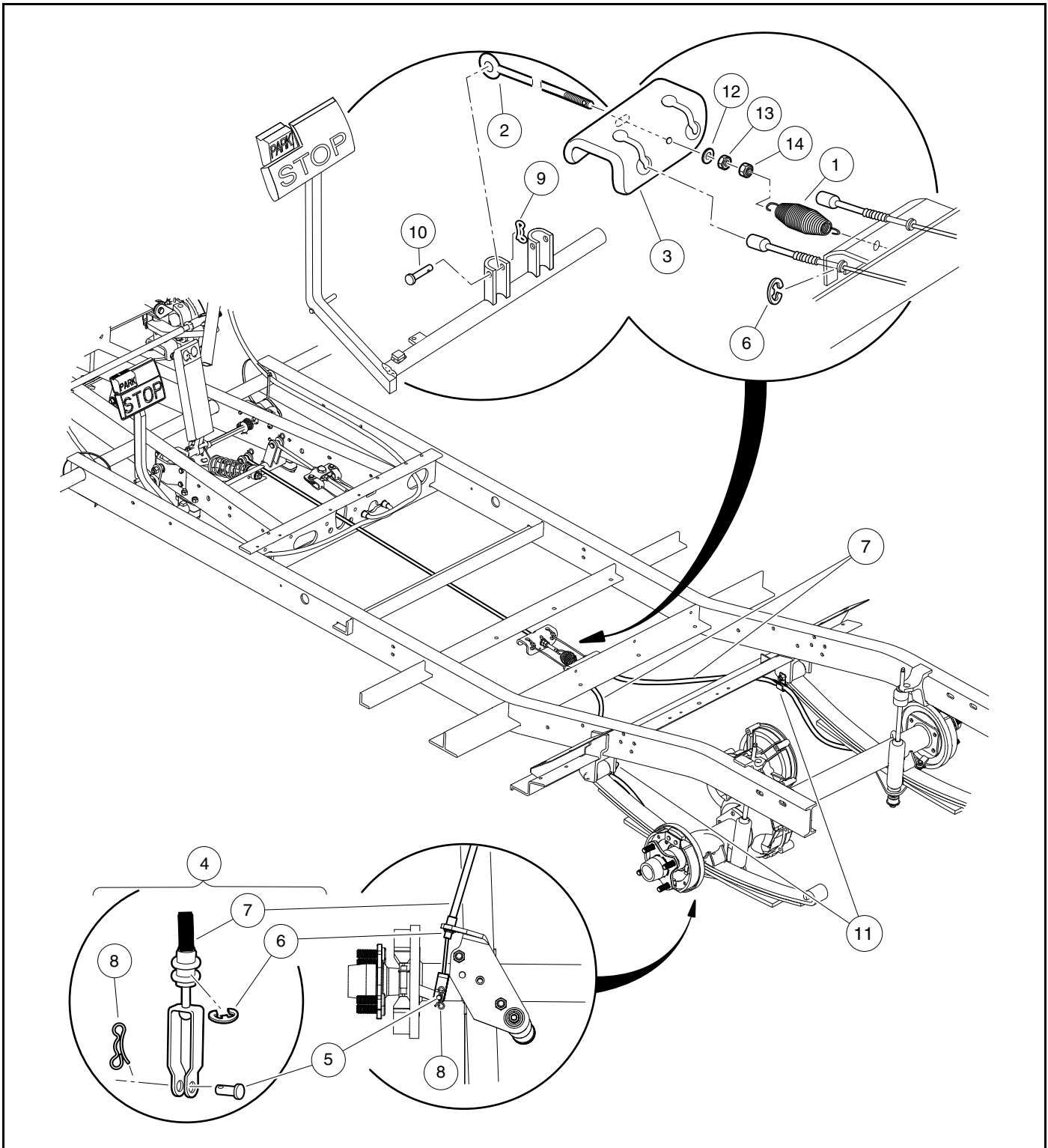

3191

Figure 6-25 Rear Brake Cables and Equalizer

REAR BRAKE CABLE REMOVAL

1. Chock wheels to keep vehicle from unintentionally moving.
2. Release park brake if latched and loosen equalizer retaining nuts (13 and 14) on equalizer rod (2) to slightly loosen brake cables (7) (**Figure 6-25, Page 6-16**).
3. Rotate brake cables (7) upward and pull ends through holes in top of equalizer (3).
4. Disconnect brake cables (7) at rear wheels.
 - 4.1. Remove bow-tie pins (8), clevis pins (5), and E-clips (6) (**Figure 6-25, Page 6-16**).
 - 4.2. Remove cable (7) from plate under leaf spring.
 - 4.3. Note location of hangers (11) and pull cables out of vehicle.

REAR BRAKE CABLE INSTALLATION

1. Place the cable ends in the equalizer (3) (**Figure 6-25, Page 6-16**). Route cables through hangers (11) in the same manner as the ones removed.
2. At the rear wheel brakes, connect the cables (7) to the brake actuator arms using clevis pins (5) and new bow-tie pins (8).
3. Place cables (7) in plate under leaf springs and secure with E-clips (6).
4. Adjust brakes. **See Brake Adjustment on page 6-6.**

Pagination Page

⚠ DANGER

- See General Warnings on page 1-1.

⚠ WARNING

- See General Warnings on page 1-1.

GENERAL INFORMATION

Steering is controlled through a rack and pinion steering assembly that is connected by a steering column to a steering wheel. No manual adjustment to the rack and pinion gear assembly is required. A spring loaded self-adjusting mechanism is incorporated into the assembly.

STEERING WHEEL

See General Warnings on page 1-1.

STEERING WHEEL REMOVAL

1. Disconnect the battery cables and either discharge the controller or disconnect the spark plug wire(s). **See Disconnecting the Batteries – Electric Vehicles, Section 1, Page 1-4.** **See Disconnecting the Battery-Gasoline Vehicles on page 1-5.**
2. Remove the two mounting screws (1) and plate (2) (**Figure 7-1, Page 7-2**).
3. Match mark the steering wheel (3) and steering column shaft (4) so when the steering wheel is removed it can be placed back in exactly the same position on steering column shaft.
4. Loosen the steering wheel nut (5) and back it off approximately 1/4 inch (6 mm). Do not remove the nut.
5. Use the steering wheel puller (CC P/N 102061201) to remove steering wheel.
 - 5.1. Place the puller anvil (6) through the top opening of the steering wheel (**Figure 7-2, Page 7-2**).
 - 5.2. Insert the anvil feet through the two slots in the base plate (marked "B") (7) as shown.
 - 5.3. Rotate the anvil screw (8) clockwise until the base plate contacts the bottom of the steering wheel where it attaches to the steering column.
 - 5.4. Use a 1/2-inch drive air impact wrench to tighten the anvil screw (8) until the steering wheel breaks free from the steering shaft.
 - 5.5. Remove the steering wheel puller.
 - 5.6. Remove the steering wheel nut (5) and the steering wheel (3) from the steering column (9) (**Figure 7-1, Page 7-2**).

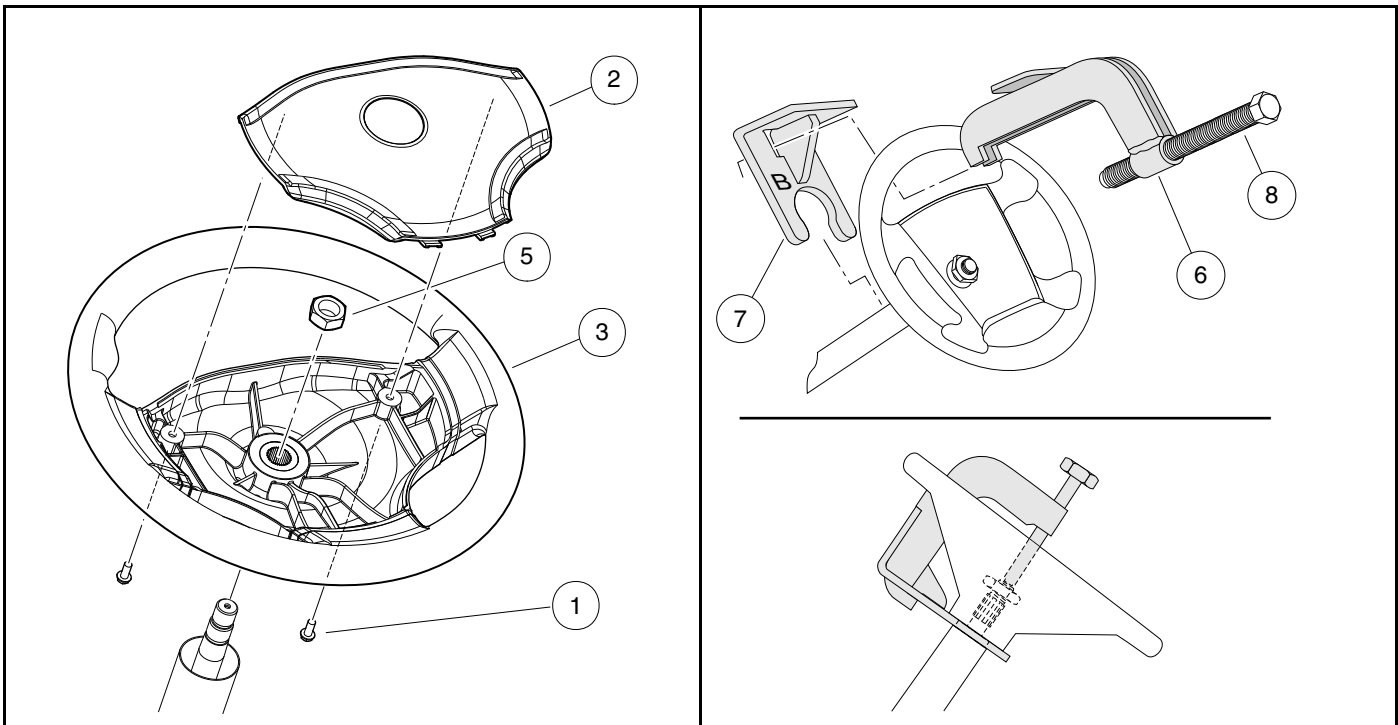

2862

Figure 7-1 Steering Wheel

1500-18300-10253

Figure 7-2 Steering Wheel Puller

STEERING WHEEL INSTALLATION

NOTE: To minimize corrosion and to make future removal of the steering wheel easier, apply a small amount of oil or anti-seize compound to steering shaft splines and taper before installing the steering wheel.

1. Install the steering wheel (3) on the splines of the steering shaft (4). Be sure to align the match marks placed on the wheel and steering column shaft in step 3 above (**Figure 7-1, Page 7-2**).
2. Install the steering wheel nut (5) and tighten to 156 in·lb (17.6 N·m).
3. Install the plate (2) and screws (1) (**Figure 7-1, Page 7-2**). Tighten screws to 16 in·lb (1.8 N·m).
4. Connect the battery cables. **See Connecting the Batteries – Electric Vehicles, Section 1, Page 1-4. See Connecting the Battery-Gasoline Vehicles on page 1-5.**

STEERING COLUMN

See General Warnings on page 1-1.

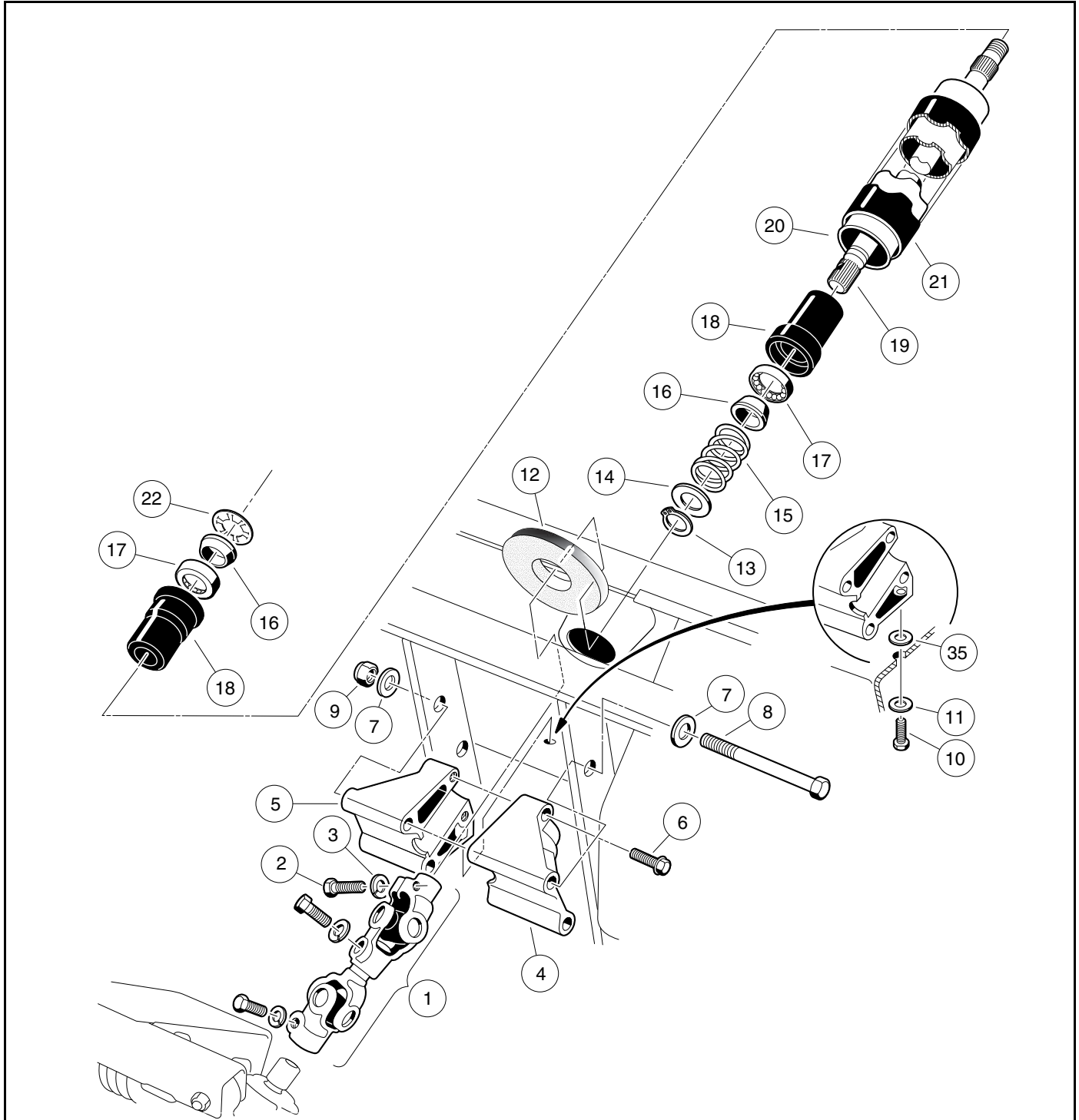

2609

Figure 7-3 Steering Column

STEERING COLUMN REMOVAL

1. Remove the steering wheel as previously instructed.
2. Remove cowl. **See Cowl Removal, Section 4, Page 4-5.**
3. Remove the upper bolt (2) and lock washer (3) from the universal joint (**Figure 7-3, Page 7-3**).
4. Remove the nuts (9), bolts (8 and 10), and washers (7 and 11) from the steering column mount (4 and 5) (**Figure 7-3, Page 7-3**).
5. Remove the steering column from the vehicle.

STEERING COLUMN DISASSEMBLY

1. Remove bolts (6) and mounts (4 and 5) from steering column. Remove boot (12) (**Figure 7-3, Page 7-3**).
2. While supporting steering column (20) on a workbench, remove snap ring (13) from shaft. **See following NOTE.**

NOTE: Do not allow the steering shaft to slide out of the steering tube when removing the snap ring.

3. Remove the washer (14), spring (15), and wedge (16).
4. Turn the steering column over and slide the shaft out of the tube to expose the retaining ring (22). Use pliers to twist the retaining ring (22) until it breaks off, then remove the wedge (16).
5. Remove the shaft (19) from the bottom of the tube (20).
6. Use steering shaft (19) to push bearing seat (18) out from the opposite end of the steering tube (20).
7. Insert a flat blade screwdriver between the bottom of the outer race of the bearing (17) and the bottom lip of the bearing seat (18) and remove the bearing (17). **See following NOTE.**

NOTE: Use new retaining rings and bearings for reassembly.

STEERING COLUMN ASSEMBLY

1. Insert bearing seat (18) into both ends of steering tube (20). Place a block of wood on bearing seat and tap lightly on block until bearing seat (18) is fully seated in steering tube (20) (**Figure 7-4, Page 7-5**).
2. Press the bearing (17) all the way into the bearing seat (18) using a steering column bearing press tool (CC P/N 1014264) or a metal tube approximately six inches (15.2 cm) long with a maximum outer diameter of 1-3/16 inches (3.3 cm) and a minimum inside diameter of 7/8 inch (2.2 cm). Be sure the bearing is installed in the bearing seat as shown (**Figure 7-4, Page 7-5**) so the wedge (16) will ride against the inner race of the bearing.
3. Install the wedge (16), spring (15), washer (14), and snap ring (13) onto the bottom end of the steering shaft (19) (**Figure 7-4, Page 7-5**).
4. Insert the shaft (19) from the bottom of the steering tube (20) (**Figure 7-3, Page 7-3**).
5. Turn the assembly over and place the shaft (19) on a bench. Install the wedge (16) and retaining ring (22) onto the top of the shaft. Be sure the prongs on the retaining ring face up and away from the wedge. Use a steering column retaining ring tool (CC P/N 1014259) to seat the retaining ring to the proper depth. Support end of tube while pressing. If you do not have the recommended tool, use the same tube as was used in step 2 to press the retaining ring onto the top of the shaft. The retaining ring should be pressed onto the shaft until 2 inches to 2-1/8 inches (5.1 cm to 5.4 cm) of the shaft extends from the top of the bearing seat in the steering tube (**Figure 7-5, Page 7-5**).

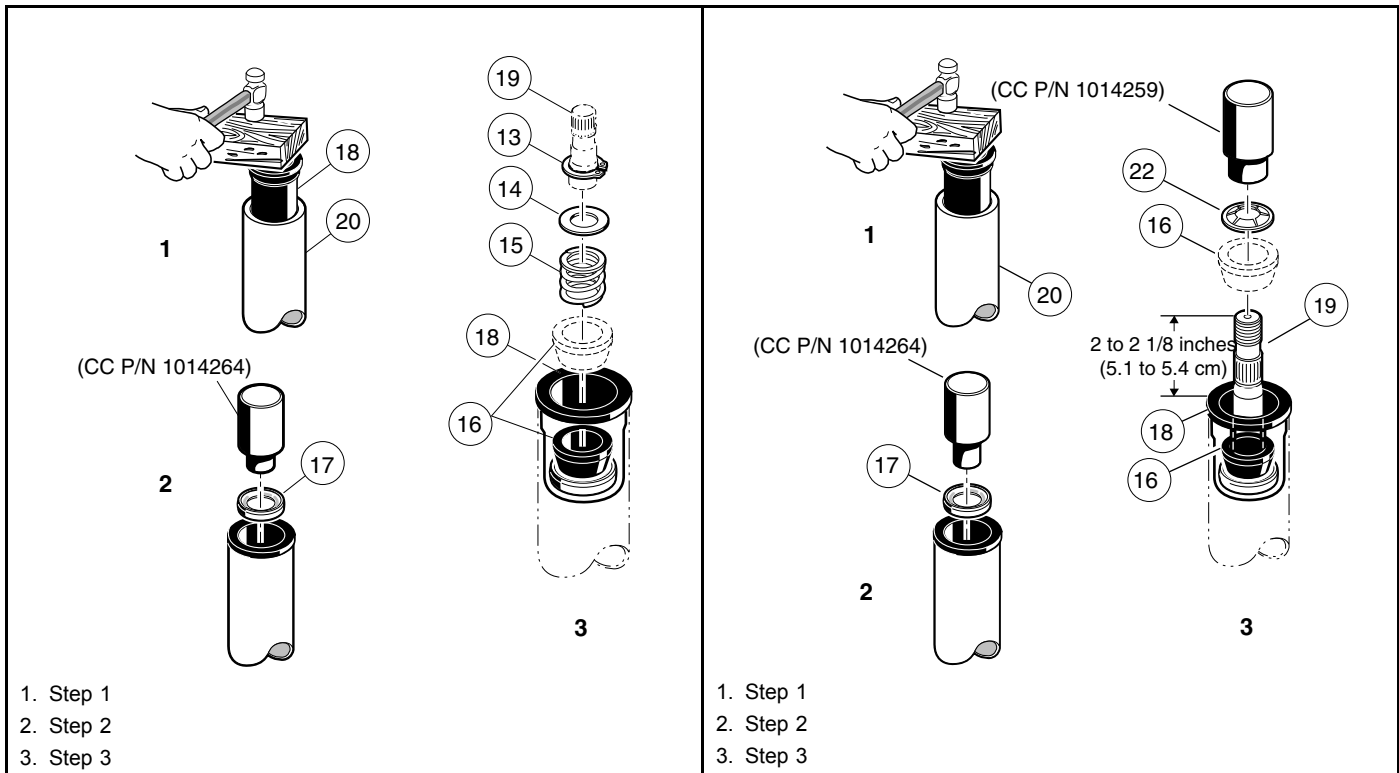

Figure 7-4 Steering Shaft – Bottom End

Figure 7-5 Steering Shaft – Top End

STEERING COLUMN INSTALLATION

1. Install boot (12). Reinstall mount (4 and 5) onto the end of the steering column. Tighten bolts (6) to 20 ft·lb (27 N·m) (**Figure 7-3, Page 7-3**).
2. For ease of assembly and to prevent corrosion, apply a light coat of anti-seize or lubricating compound to both splined ends of the steering shaft.
3. Position the steering column assembly in the vehicle while inserting the steering column shaft into the upper universal joint (1). The flat portion of the steering shaft spline (19) must be aligned with the bolt hole in the universal joint (1) before sliding the spline into the universal joint. While holding the steering column in place, attach it to the frame using bolts (8), washers (7), and nuts (9) (**Figure 7-3, Page 7-3**). Thread the nuts onto the bolts but do not tighten them.
4. Install wide washer (35), washer (11) and screw (10). Tighten to 20 ft·lb (27 N·m) (**Figure 7-3, Page 7-3**).
5. Install the bolt (2) and lock washer (3) on the upper universal joint and finger-tighten.
6. Tighten the two nuts (9) and bolts (8) to 18 ft·lb (24.4 N·m) (**Figure 7-3, Page 7-3**).
7. Tighten the bolt (2) on the upper universal joint to 15 ft·lb (20 N·m) (**Figure 7-3, Page 7-3**).
8. Check the other two bolts of the universal joint (1) to ensure that they are properly tightened to 15 ft·lb (20 N·m) (**Figure 7-3, Page 7-3**).
9. Install cowl. **See Cowl Installation, Section 4, Page 4-5.**
10. Install the steering wheel. **See Steering Wheel Installation on page 7-2.**

STEERING ADJUSTMENT

See General Warnings on page 1-1.

1. Turn the steering wheel all the way to the right. Note the distance between the passenger side spindle stop (2) and passenger side A-plate (3) (**Figure 7-6, Page 7-8**). The internal stop on the rack must reach its limit of travel against rack and pinion housing at exactly the same time the spindle stops against the passenger side A-plate (with vehicle wheels turned to the right). If simultaneous contact occurs, steering is in correct adjustment; proceed to step 4. If simultaneous contact does not occur, proceed to step 2.
2. Loosen the nuts (27 and 29) and turn the drag link (28) (**Figure 7-10, Page 7-10**) to adjust the drag link rod. Adjust the link rod with the steering wheel turned all the way to the right, so the passenger side spindle stop lightly touches the passenger side A-plate. The internal stop on the rack must reach its limit of travel at the same time the spindle stops against the passenger side A-plate (with vehicle wheels turned to the right). **See following CAUTION.**

CAUTION

- **The drag link has both left and right-hand threads. The end of the drag link toward the spindle has left-hand threads, and the end toward the rack has right-hand threads. To prevent damage to threaded parts, care should be taken when servicing the drag link.**
3. When all adjustments have been completed, tighten the nuts (27 and 29) on the drag link assembly with an open end wrench. Tighten nuts to 21 ft·lb (28.4 N·m) (**Figure 7-10, Page 7-10**). **See following CAUTION.**

CAUTION

- **When tightening the nuts (27 and 29), make sure the drag link (28) does not turn (Figure 7-10, Page 7-10).**
4. Straighten wheels and turn steering wheel from lock to lock. Wheels should turn smoothly and easily. If steering wheel does not turn smoothly and easily, inspect steering assemblies as follows:
 - ball joints (23) (**Figure 7-10, Page 7-10**) and (6 and 13) (**Figure 7-18, Page 7-18**)
 - spindle bushings (3 and 4) (**Figure 7-19, Page 7-19**)
 - wave washers (20) (**Figure 7-19, Page 7-19**)
 - rack assembly (17) (**Figure 7-10, Page 7-10**)
 5. Also inspect front suspension assemblies as follows:
 - A-plates (1) (**Figure 7-18, Page 7-18**)
 - urethane bushings (2) (**Figure 7-18, Page 7-18**)
 - leaf springs (6) (**Figure 7-19, Page 7-19**)
 6. Replace components as necessary.

RACK AND PINION

See General Warnings on page 1-1.

CAUTION

- **Front impacts that bend tie rods and/or drag links can possibly damage internal steering gear components. See Rack and Pinion Inspection on page 7-7. The manufacturer recommends inspecting the rack and pinion and replacing if damaged.**

RACK AND PINION INSPECTION

1. Look for obvious damage to the chassis, where the rack and pinion is mounted, and the rack and pinion housing. Particularly check the housing for broken mounting points.
2. Compare the toe-in against the specification. **See Toe-in Adjustment on page 7-16.**
3. If obvious visible damage is found, such as a bent tie rod, check the steering gear for abnormal free-play, noise, binding or clunking while it is under a load. With the steering system fully assembled and all four tires on the ground/floor, turn the steering wheel from stop to stop. While turning, feel for any binding, clunking or tight/loose spots. Listen for unusual noises. Replace the rack and pinion as an assembly if any is found.
4. In the event of an known impact and obvious visible damage is not found in the method described above, disconnect the tie rods and/or drag links from the spindles. Turn the steering wheel from stop to stop. While turning, feel for any binding or tight/loose spots. Listen for unusual noises. Replace the rack and pinion as an assembly if any is found.

RACK AND PINION REMOVAL – MAINTENANCE-FREE BALL JOINTS

1. Remove the front body. **See Front Body, Section 4, Page 4-3.**
2. Remove the drag link ball joint retaining nut (25) **(Figure 7-10, Page 7-10).**
3. Remove the outer drag link ball joint (23) from the spindle assembly (33) and inspect for excessive wear and seal damage.
4. Remove the bolts (30), washers (31), and lock nuts (32) from the steering rack assembly mounting bracket **(Figure 7-10, Page 7-10).**
5. Remove the bolt (2) and flat washer (3) on the upper universal joint, then remove the rack assembly and universal joint from the vehicle **(Figure 7-3, Page 7-3).**

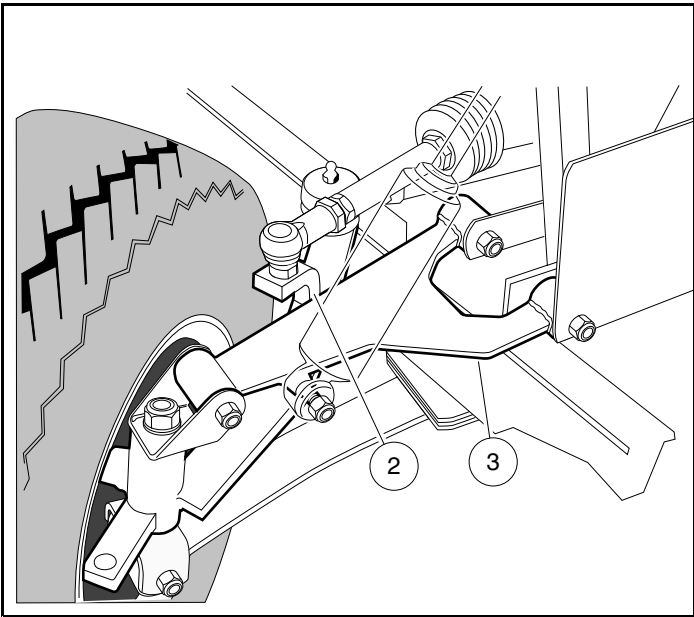

1838

Figure 7-6 Adjust Steering Alignment

RACK AND PINION DISASSEMBLY

CAUTION

- The ball joint (23) (Figure 7-10, Page 7-10) has left-hand threads.
1. Remove ball joint from the spindle and inspect it for excessive wear.
 2. Remove the drag link (28) (Figure 7-10, Page 7-10).
 3. Remove both bellows clamps (2) (plastic wire ties).
 4. Remove the hex nut (29) and slide off the dust seal bellows (1).
 5. Remove the retaining ring (21), then slide off dust seal bellows (20).
 6. Remove the rack screw lock nut (15), rack guide screw (16), rack guide pressure spring (14), and the rack guide (13) (Figure 7-10, Page 7-10).
 7. Remove the universal joint assembly from the pinion (8) by fully removing the bolt and then sliding off the universal joint.

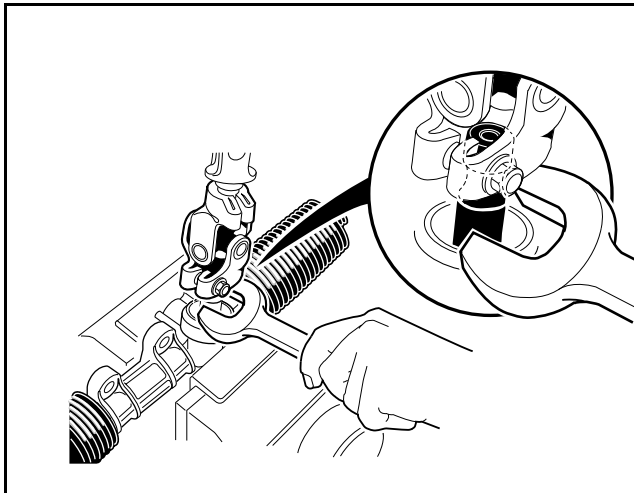

1500-18400-10259

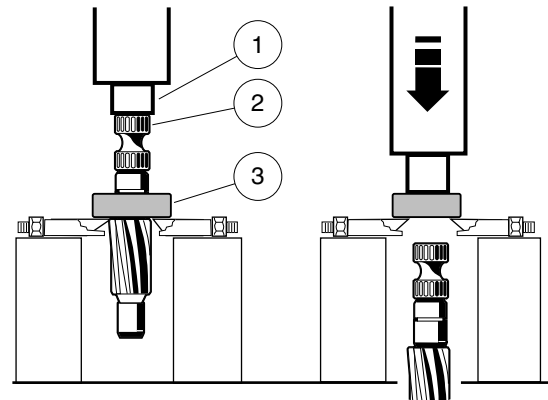
Figure 7-7 Remove Pinion from Housing

1. Press Ram 2. Pinion Gear 3. Bearing

1500-18400-10260

Figure 7-8 Remove Bearing from Pinion

8. If necessary, remove the dust seal (12). **See following NOTE.**

NOTE: If the dust seal (12) is removed, replace with a new one.

9. Use snap ring pliers to remove the internal snap ring (11) (**Figure 7-10, Page 7-10**).
10. Install the universal joint onto the pinion and place a large open end wrench under the universal joint (**Figure 7-7, Page 7-9**). Use the wrench as a lever to pull the pinion from the housing.
11. If the ball bearing (9) has been damaged, remove the external snap ring (10) (**Figure 7-10, Page 7-10**) and press the bearing off (**Figure 7-8, Page 7-9**).
12. Remove retaining ring (19) and stop washer (18), then remove rack (17) from housing (6) (**Figure 7-10, Page 7-10**).
13. If the inner ball joint (3) is excessively worn, remove the ball joint and tab washer (4) from the rack (**Figure 7-9, Page 7-9**).
- 13.1. Secure the rack in a vise using wood blocks (5) between the rack and the jaws of the vise to protect the rack from damage (**Figure 7-9, Page 7-9**).
- 13.2. Loosen and remove the inner ball joint with a wrench.

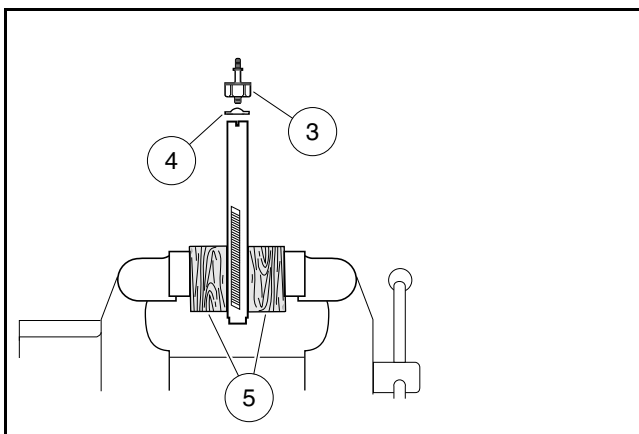

1500-18400-10261

Figure 7-9 Secure Rack in Vise

14. Inspect the bushing (5) for excessive wear. If wear is excessive, replace the steering box assembly (CC P/N 101878302) (**Figure 7-10, Page 7-10**).

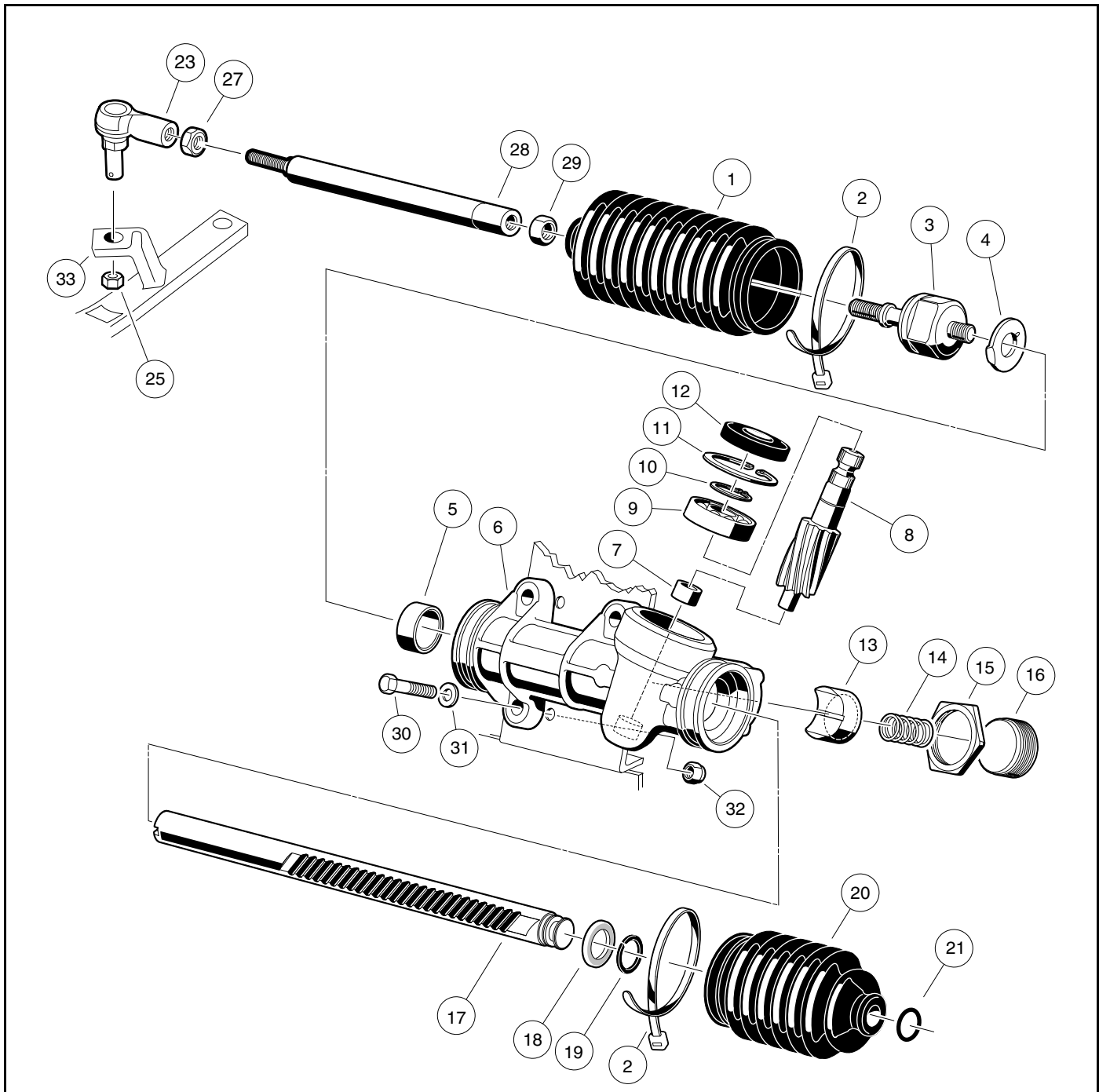

1839

Figure 7-10 Steering Gear – Maintenance-Free Ball Joints

RACK AND PINION ASSEMBLY

1. Install a new tab washer (4) and an inner ball joint (3) (**Figure 7-9, Page 7-9**). Install the ball joint onto the rack by securing the rack in a vise using wood blocks between the rack and the jaws of the vise to protect the rack from damage. Tighten the ball joint to 60 ft·lb (81 N·m).
2. Bend the edges of the tab washer (4) up against the ball joint (3) (**Figure 7-9, Page 7-9**).

3. Apply a light coating of EP grease to the teeth of the rack (17), then slide the rack through the bushing (5) and housing (6). Install the stop washer (18) and retaining ring (19) to the end of the rack (**Figure 7-10, Page 7-10**).

CAUTION

- In step 4, do not press against the outer race of the bearing.
4. If the bearing (9) was removed, press on a new bearing, exerting all pressure on the inner race (grease the bearing before installing it). Then install the external snap ring (10) (**Figure 7-10, Page 7-10**). **See preceding CAUTION.**
 5. If the needle bearing (7) is damaged, the steering box assembly (CC P/N 101878302) must be replaced (**Figure 7-10, Page 7-10**).
 6. Install pinion (8) and bearing (9) assembly into the housing (6) (**Figure 7-10, Page 7-10**). Make sure the rack gear teeth will mesh with the gear teeth on the pinion. The rack may need to be rotated slightly while lightly tapping on the pinion-bearing assembly with a rubber mallet. **See following CAUTION.**

CAUTION

- Do not force the pinion-bearing assembly into the housing. The gear teeth or the small bearing could be damaged.

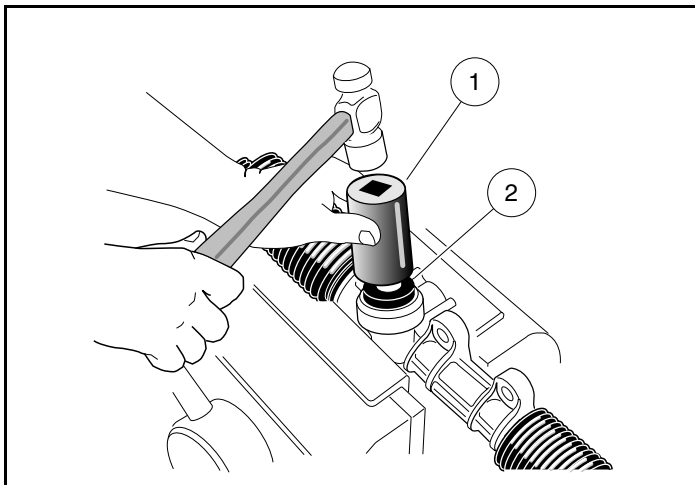

1500-18400-10263

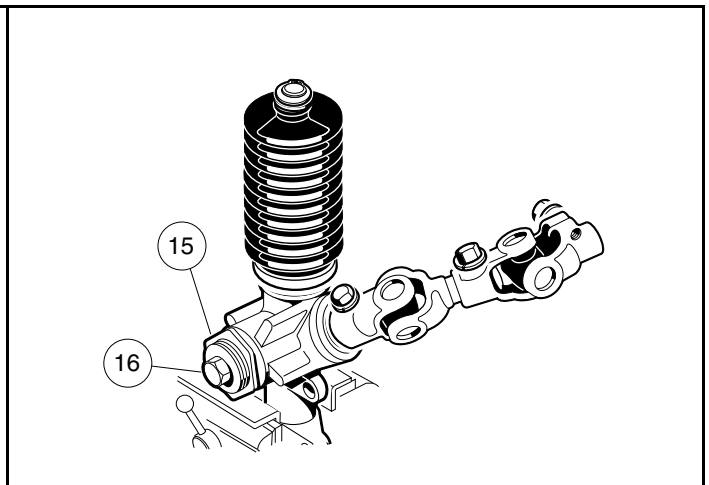
Figure 7-11 Press In Dust Seal

1500-18400-10264

Figure 7-12 Rack and Pinion Adjustment

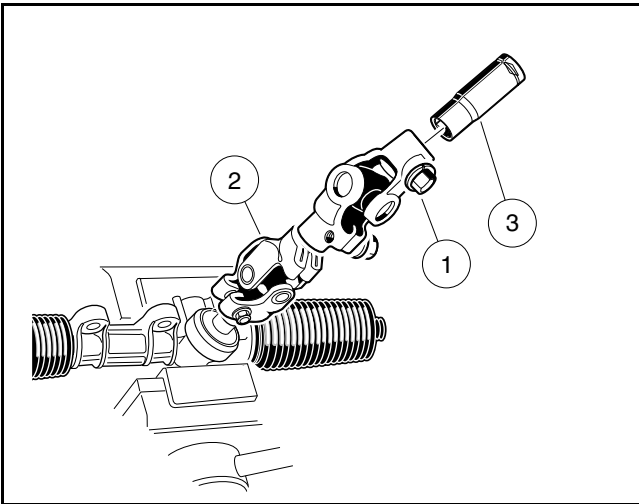

1500-18400-10265

Figure 7-13 Rack and Pinion Resistance

7. Install the internal snap ring (11) (**Figure 7-10, Page 7-10**).
8. Using an appropriate size deep well socket (1) to apply pressure evenly, press in a new dust seal (2) (**Figure 7-11, Page 7-11**).
9. Apply a small amount of grease to the rack guide (13) where it comes into contact with the rack (17) (**Figure 7-10, Page 7-10**).
10. Place a few drops of Loctite® 222 to the threads of the screw (16) (**Figure 7-10, Page 7-10**).
11. Install the rack guide (13), pressure spring (14), and screw (16). The screw should be threaded in until a rotational torque of 10 in·lb (1.13 N·m) is achieved (**Figure 7-10, Page 7-10**).
- 11.1. Reposition the rack and pinion in a vise.
- 11.2. Insert a 3/8-inch deep well socket (3) into the steering column end of the universal joint (2) and tighten the bolt (1) to 15 ft·lb (20.3 N·m) (**Figure 7-13, Page 7-12**).
- 11.3. Use a torque wrench connected to the 3/8-inch deep well socket (3) to measure the resistance of the rack and pinion. Rotational resistance should measure 7 to 15 in·lb (0.8 to 1.7 N·m).
- 11.4. If measured resistance does not equal 7 to 15 in·lb, loosen the lock nut (15) and tighten the screw (16) until it bottoms out, then back the screw off one quarter turn. Tighten the lock nut to 28 ft·lb (38 N·m) (**Figure 7-12, Page 7-11**). **See following NOTE.**

NOTE: When tightening the lock nut (15) make sure the screw (16) does not change adjustment (**Figure 7-12, Page 7-11**).

12. Install the dust seal bellows (20) and retaining ring (21) (**Figure 7-10, Page 7-10**).
13. Install the dust seal bellows (1) and hex nut (29) (**Figure 7-10, Page 7-10**).
14. Install the universal joint on the pinion. Tighten the bolt to 15 ft·lb (20 N·m).
15. Install new bellows clamps (wire ties) (2) (**Figure 7-10, Page 7-10**).
16. Install the drag link (28) by fully threading the ground end into the inner ball joint (3). **See following CAUTION.**

CAUTION

- The ball joint (23) (**Figure 7-10, Page 7-10**) has left-hand threads.
 - The tie rod and drag link have right-hand threads on one end and left-hand threads on the other end. Right-hand threads are identified by a groove in the tie rod or drag link.
17. Install the ball joint (23) (**Figure 7-10, Page 7-10**). **See preceding CAUTION.**

RACK AND PINION INSTALLATION – MAINTENANCE-FREE BALL JOINTS

1. Position the steering gear box assembly on the shock and gear support and install the bolts (30), washers (31), and nuts (32). Do not tighten the mounting bolts (**Figure 7-10, Page 7-10**).
2. For ease of assembly and to prevent corrosion, apply a light coat of anti-seize and lubricating compound to the splined end of the steering column shaft.
3. Align the flat portion of the steering shaft spline with the bolt hole in the universal joint and then slide the shaft into the upper universal joint. Install the bolt and lock washer on the upper universal joint and tighten it to 15 ft·lb (20 N·m).
4. Tighten the steering rack mounting bolts (30) to 22 ft·lb (29.8 N·m) (**Figure 7-10, Page 7-10**).
5. Install the drag link ball joint (23) on the spindle arm riser (33) and secure with retaining nut (25). Tighten nut to 40 ft·lb (54 N·m).
6. Adjust the steering. **See Steering Adjustment on page 7-6.**

TIE ROD AND DRAG LINK

See General Warnings on page 1-1.

TIE ROD AND DRAG LINK REMOVAL – MAINTENANCE-FREE BALL JOINTS

1. Using locking pliers to hold tie rod and drag link, loosen jam nuts (7 and 12) on tie rod ball joints (**Figure 7-18, Page 7-18**) and loosen jam nuts (27 and 29) on the drag link (**Figure 7-10, Page 7-10**).
2. Remove the ball joint retaining nuts (20) (**Figure 7-18, Page 7-18**).
3. Remove ball joints (6 and 13) (**Figure 7-18, Page 7-18**) and (23) (**Figure 7-10, Page 7-10**) from the spindles.
4. Remove the ball joints from the tie rod (11) (**Figure 7-18, Page 7-18**).
5. Remove drag link (28) from inner ball joint assembly (3) and drag link ball joint (23) (**Figure 7-10, Page 7-10**).

TIE ROD AND DRAG LINK INSTALLATION – MAINTENANCE-FREE BALL JOINTS

1. Thread ball joints (6 and 13) into tie rod (11) to a depth of 1/2-inch (12.5 mm) (**Figure 7-18, Page 7-18**). See following **WARNING** and **CAUTION**.

⚠ WARNING

- The ball joints must be threaded into the rod at least 5/16 of an inch (8 mm). Failure to thread ball joints in deep enough may cause a ball joint to separate from the rod during adjustment or while being operated, possibly resulting in loss of vehicle control and severe personal injury.

CAUTION

- The tie rod and drag link have right-hand threads on one end and left-hand threads on the other end. Right-hand threads are identified by a groove in the tie rod or drag link.
2. Attach the tie rod ball joints (6 and 13) to the spindle tabs (23), then install and tighten the nuts (20) to 40 ft·lb (54 N·m) (**Figure 7-18, Page 7-18**).
 3. Thread the drag link rod (28) all the way onto the threaded stud of the inner ball joint assembly (3) (right-hand threads) (**Figure 7-10, Page 7-10**).
 4. Thread the ball joint (23) into the drag link rod (28) (left-hand threads) to full thread depth (**Figure 7-10, Page 7-10**).
 5. Install the drag link ball joint (23) on the spindle arm riser (33) and secure with retaining nut (25) (**Figure 7-10, Page 7-10**). Tighten nut to 40 ft·lb (54 N·m).
 6. Adjust camber and toe-in. See **Camber Adjustment** on page 7-15 and **Toe-in Adjustment** on page 7-16.
 7. Adjust steering. See **Steering Adjustment** on page 7-6.

FRONT SUSPENSION

See General Warnings on page 1-1.

LUBRICATION

Two grease fittings (one in each spindle housing) are provided. Lubricate these fittings at the recommended interval with the proper lubricant. **See Periodic Lubrication Schedules, Section 10, Page 10-7.**

WHEEL ALIGNMENT

Wheel alignment is limited to equalizing the camber angle of each front wheel and adjusting toe-in of the front wheels. There is also a drag link adjustment to equalize the turning radius in both directions. **See Steering Adjustment on page 7-6. See following NOTE.**

NOTE: Prior to making any front suspension adjustments, inspect components for wear and damage and repair or replace as necessary.

Camber Adjustment

1. Check each front wheel with a framing square. At the floor (or ground), there should be an equal amount of space between each tire and the framing square (**Figure 7-14, Page 7-15**).
2. Loosen, but do not remove, the four nuts (32) that secure the leaf spring (6) to the bottom spring plate (29) (**Figure 7-19, Page 7-19**). **See also Figure 7-15, Page 7-15.**

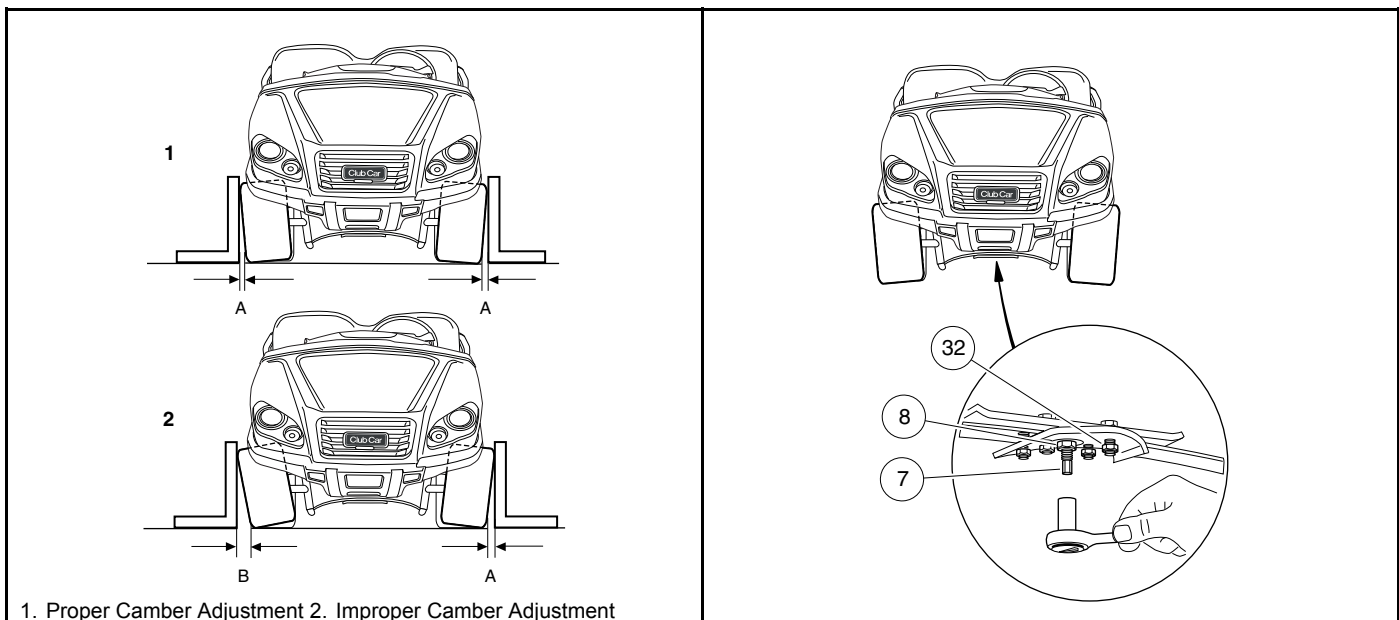

1. Proper Camber Adjustment 2. Improper Camber Adjustment

2868

Figure 7-14 Check Camber

2869

Figure 7-15 Adjust Camber

3. Loosen, but do not remove, the hex nut (8) on the adjustment eccentric (7) (**Figure 7-19, Page 7-19**) in the center of the spring. **See also Figure 7-15, Page 7-15.**
4. Use a 7 mm deep well socket to rotate the eccentric (**Figure 7-15, Page 7-15**).
5. After adjusting camber, tighten the four spring retaining nuts (32) (**Figure 7-19, Page 7-19**) to 23 ft-lb (31 N·m). Then roll the vehicle forward one full tire revolution and recheck the camber. Adjust as required. **See also Figure 7-14, Page 7-15.**

- Tighten the hex nut (8) on the adjustment eccentric (7) to 23 ft·lb (31 N·m) (**Figure 7-19, Page 7-19**). See also **Figure 7-15, Page 7-15**.

Toe-in Adjustment

- On a level surface, roll the vehicle forward, then stop. Make sure the front wheels are pointed straight ahead. Do not turn the steering wheel again during this procedure.
- On each front tire, mark (as closely as possible) the center of the tread face that is oriented toward the rear of the vehicle. The marks should be even with the bottom surfaces of the vehicle frame I-beams.
- Measure the distance between the marks on the rear-facing surfaces of the tires, and then roll the vehicle **forward** one and a half wheel revolutions until the marks appear on the forward facing surfaces of the tires at about the same height from the floor (**Figure 7-16, Page 7-16**).

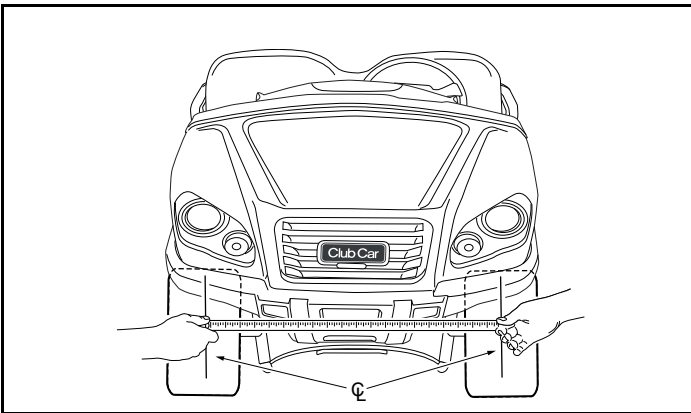

2870

Figure 7-16 Check Toe-In

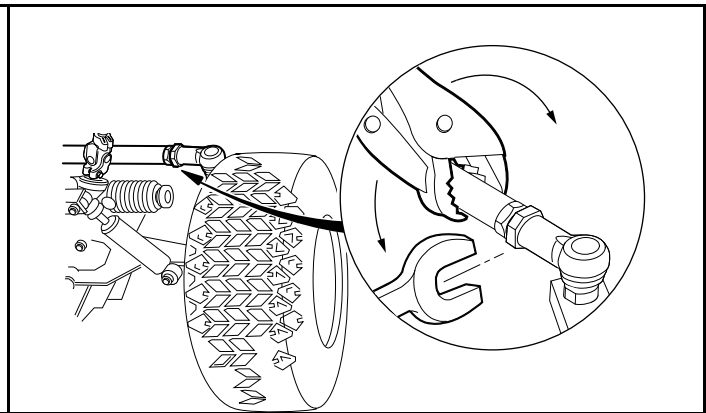

2620

Figure 7-17 Adjust Toe-In

- Measure the distance between the marks on the forward-facing surfaces of the tires. **See following NOTE.**

NOTE: The front measurement must be less than the rear measurement.

- Subtract the measurement on the front of the tires from the measurement on the rear of the tires. The difference is the toe-in. Proper toe-in is 1/8 to 3/8 of an inch (3.2 to 9.5 mm).
- If adjustment is necessary, loosen the jam nut on each tie rod ball joint and rotate the tie rod to increase or decrease toe-in (**Figure 7-17, Page 7-16**). **See following CAUTION.**

CAUTION

- The tie rod has right-hand threads on one end and left-hand threads on the other end. Right-hand threads are identified by a groove in the tie rod.
- Tighten nuts (loosened in step 6) to 21 ft·lb (28 N·m) and recheck toe-in.
 - After toe-in adjustment is made and with wheels in the straight ahead position, the steering wheel should be at the center of its travel. There should be equal travel to the left and right. **See following NOTE.**

NOTE: If the minimum turning radius is not the same for both left and right turns, adjust the steering. **See Steering Adjustment on page 7-6.**

FRONT SUSPENSION COMPONENTS

See General Warnings on page 1-1.

LEAF SPRING REMOVAL

1. Disconnect the battery cables and either discharge the controller or disconnect the spark plug wire(s). **See Disconnecting the Batteries – Electric Vehicles, Section 1, Page 1-4.**
See Disconnecting the Battery-Gasoline Vehicles on page 1-5.
2. Remove both front wheels. **See Wheel Removal, Section 8, Page 8-1.**
3. Remove the nuts (14) and bolts (25) from the bottom of each king pin (26) (**Figure 7-19, Page 7-19**).
4. Remove the four bolts (30), four nuts (32), four lock washers (31), and bottom spring plate (29).
5. Remove leaf spring (6).
6. Check the condition of the urethane bushings (27) and steel sleeves (28). Replace any that are worn or damaged.

LEAF SPRING INSTALLATION

1. Install urethane bushings (27) and steel sleeves (28) into leaf spring eyes (**Figure 7-19, Page 7-19**).
2. Install tapered leaf spring (6), bottom spring plate (29), four bolts (30), four lock washers (31), and four nuts (32). Using a crisscross pattern sequence, tighten bolts to 23 ft·lb (31 N·m).
3. Install spring in king pins (26) with bolts (25) and nuts (14). Tighten to 17 ft·lb (23 N·m).
4. Install the wheels and lower the vehicle. **See Wheel Installation, Section 8, Page 8-1.**
5. Adjust camber and toe-in. **See Camber Adjustment on page 7-15 and Toe-in Adjustment on page 7-16.**

KINGPIN AND STEERING SPINDLE REMOVAL – MAINTENANCE-FREE BALL JOINTS

1. Remove the front hub. **See Front Hub and Wheel Bearings Removal on page 7-21.**
2. Remove nuts (20) and remove ball joints from spindles (**Figure 7-18, Page 7-18**). Remove drag link ball joint. **See also Tie Rod and Drag Link Removal – Maintenance-Free Ball Joints on page 7-14.**
3. Remove the lock nut (17) and conical washer (34) from the top of the kingpin (26) (**Figure 7-19, Page 7-19**).
4. Raise the upper clevis (16) from the kingpin.
5. Remove the flat washer (33) and thrust washer (19).
6. Slide the spindle (1 or 2) off the kingpin (26).
7. Remove the wave washer (35) and inspect it. If the washer is broken or has a wave bottom to wave crest height dimension of less than 0.040 inch (0.10 cm), it must be replaced.
8. Remove bolt (25) and nut (14) from bottom of kingpin (26) and remove kingpin.
9. Inspect the kingpin and spindle. If either is worn or damaged, it must be replaced.
10. Inspect the bushings (3 and 4). If the bushings are worn or damaged, remove them and press in new ones. **See following NOTE.**

NOTE: If the bushings are replaced, ream new bushings from 0.750 inch to 0.752 inch (19.05 to 19.10 mm) in diameter. The reamer should be long enough to ream both bushings from one direction.

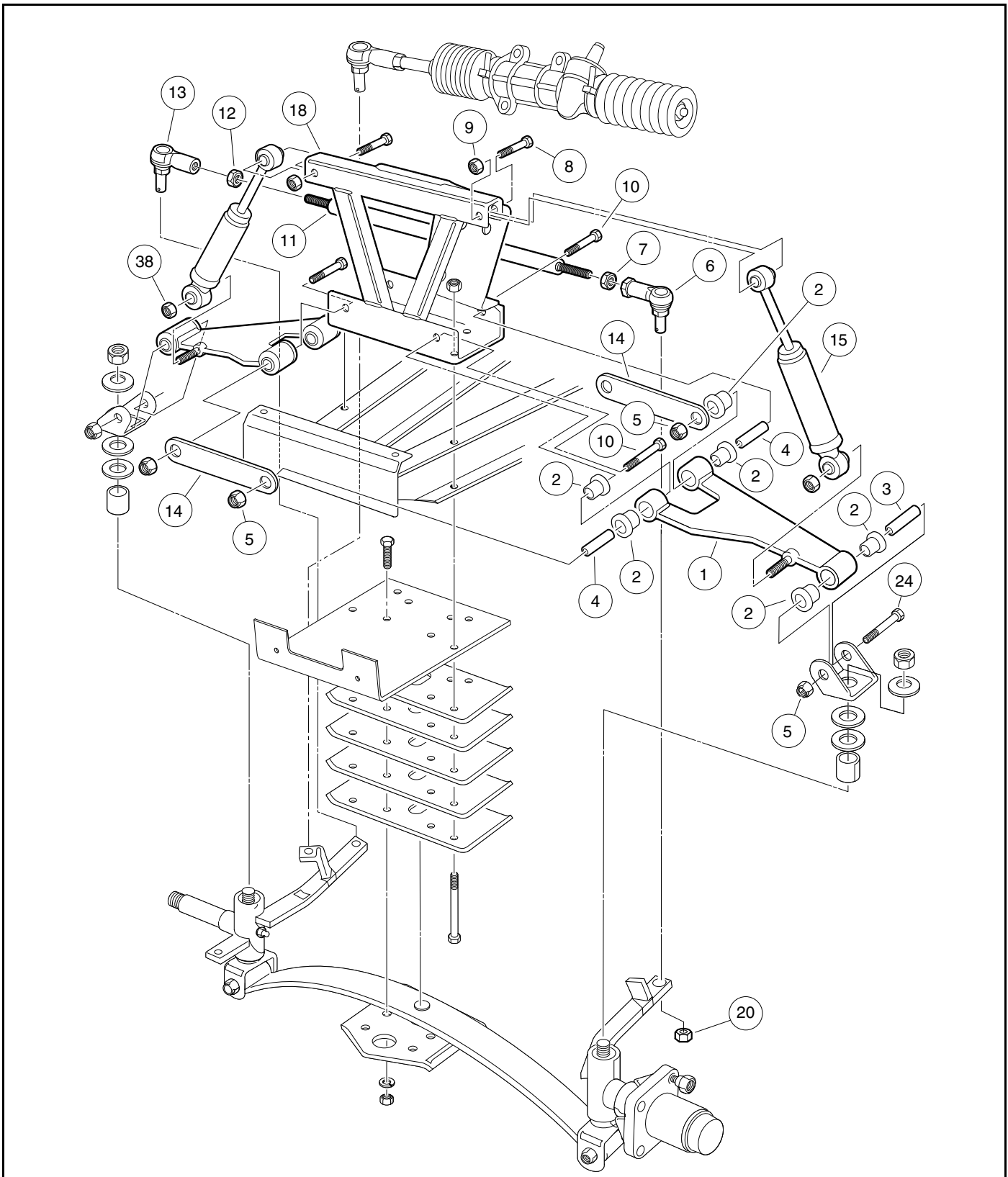

2610

Figure 7-18 Front Suspension – Upper Portion

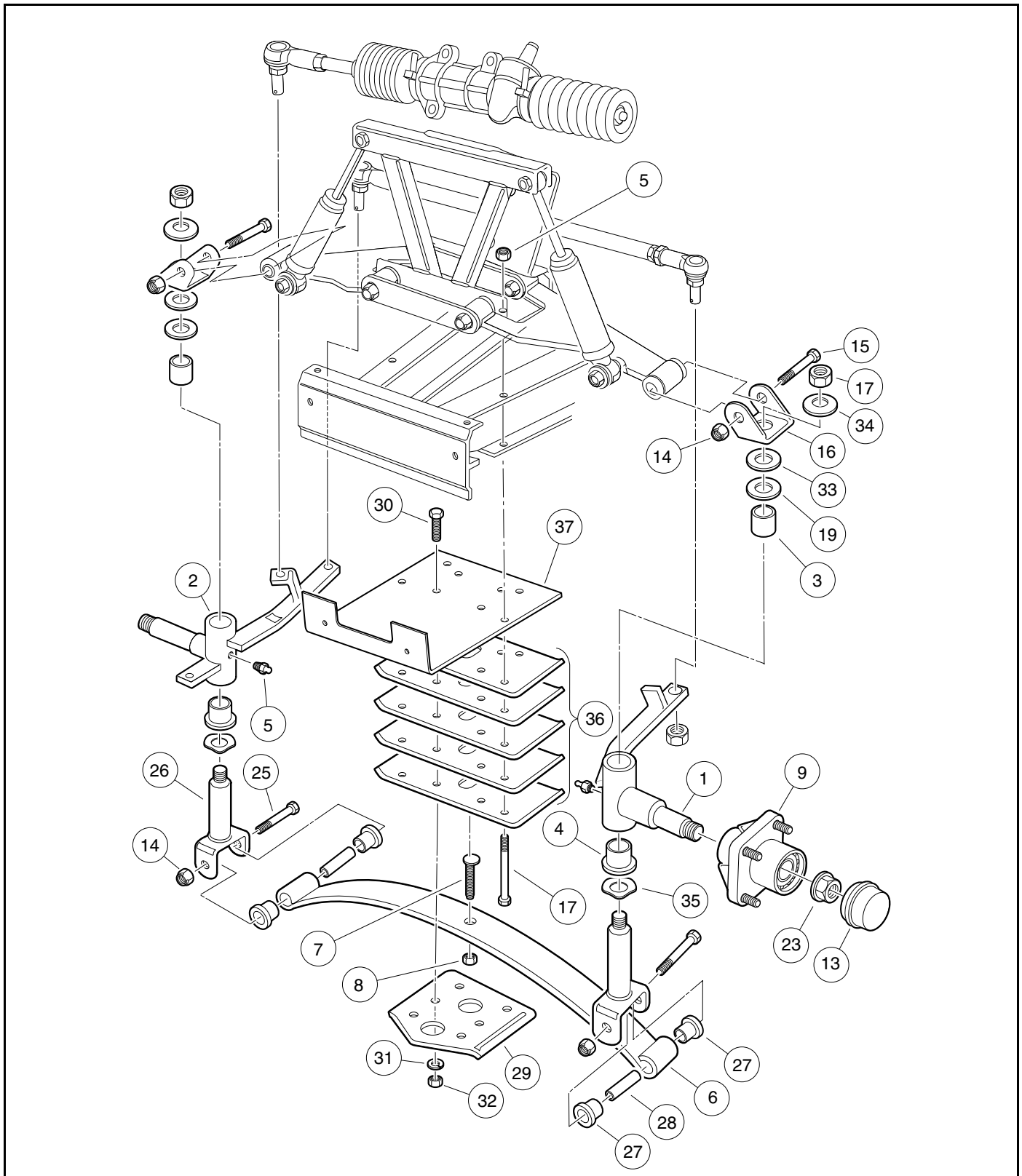

2611

Figure 7-19 Front Suspension – Lower Portion

KINGPIN AND STEERING SPINDLE INSTALLATION – MAINTENANCE-FREE BALL JOINTS

1. Inspect all parts and replace them as necessary.
2. Install the kingpin (26) over the leaf spring eye. Insert the bolt (25) and install the nut (14) (**Figure 7-19, Page 7-19**). Tighten the bolt to 17 ft·lb (23 N·m).
3. Install the wave washer (35).
4. Install the steering spindle on the kingpin. Then install the thrust washer (19), flat washer (33), upper plate clevis (16), conical washer (34), and nut (17). Tighten the nut to 65 ft·lb (88 N·m).
5. Attach the tie rod ball joints (6 and 13) to the spindle tabs, then install and tighten the nuts (20) to 40 ft·lb (54 N·m) (**Figure 7-18, Page 7-18**).
6. Install the drag link ball joint. **See Tie Rod and Drag Link Installation – Maintenance-Free Ball Joints on page 7-14.**
7. Install front hub and wheel. **See Front Hub and Wheel Bearings Installation on page 7-22.**

DELTA A-PLATE REMOVAL

1. Remove front wheel(s). **See Wheel Removal, Section 8, Page 8-1.**
2. Remove bolts (10 and 24), A-Plate straps (14), and nuts (5) (**Figure 7-18, Page 7-18**).
3. Remove the lower shock absorber mounting nut (38), then slide the shock absorber (15) free of the Delta A-Plate (1).
4. Remove the Delta A-Plate (1).
5. Inspect the bushings (2) and sleeves (3 and 4) in the Delta A-Plate and replace them if necessary.

DELTA A-PLATE INSTALLATION

1. Install the A-Plate (1) in reverse order of removal. Tighten the A-Plate suspension bolts (10 and 24) to 20 ft·lb (27 N·m) (**Figure 7-18, Page 7-18**).
2. Tighten shock absorber mounting nut (38) to 20 ft·lb (27.1 N·m).
3. Install the wheel(s). **See Wheel Installation, Section 8, Page 8-1.**
4. Adjust the wheel alignment. **See Wheel Alignment on page 7-15.**

SHOCK ABSORBER REMOVAL

1. Inspect the shock absorbers (15) for fluid leakage at the point where the shaft enters the shock absorber body. Leaking shock absorbers should be replaced.
2. Remove the nut (38) attaching the shock absorber to the A-Plate (1) (**Figure 7-18, Page 7-18**).
3. Remove the nut (9) and bolt (8) attaching the shock absorber to the shock and gear support (18).
4. Remove the shock absorber (15).

SHOCK ABSORBER INSTALLATION

NOTE: When installing shock absorbers, make sure front shocks have identical part numbers and rear shocks have identical part numbers.

1. Install the shock absorber by reversing the removal procedure.
2. Tighten the nuts (9 and 38) to 20 ft·lb (27 N·m).

FRONT WHEEL BEARINGS AND HUBS

See General Warnings on page 1-1.

FRONT WHEEL FREE PLAY INSPECTION

1. Raise the front of the vehicle.
2. Using your hands, attempt to rock the wheel and hub assembly back and forth on the spindle. If there is any observable movement of the wheel and hub on the spindle, remove dust cap (1) and cotter pin (2) and then tighten the spindle nut (3) until the bearing (5) fully seats in the bearing race (7) (**Figure 7-20, Page 7-21**).
3. Loosen spindle nut one cotter pin position. If the hub does not turn freely, loosen spindle nut one more cotter pin position.
4. Install a new cotter pin (2). If movement continues, replace the wheel bearings (5) as required (**Figure 7-20, Page 7-21**).

FRONT HUB AND WHEEL BEARINGS REMOVAL

1. Remove the front wheels. **See Wheel Removal on page 8-1.**
2. Remove the front wheel hubs.
 - 2.1. Remove dust cover (1), cotter pin (2), spindle nut (3), and flat washer (8) (**Figure 7-20, Page 7-21**).
 - 2.2. Remove the hub assembly (4) from the spindle shaft (**Figure 7-20, Page 7-21**).
3. Remove the seal (6) and the bearings (5) from the hub (**Figure 7-20, Page 7-21**).
4. Inspect the bearing cups (7). If they are worn or pitted, remove the cups by inserting a drift punch from the opposite end of the hub and tapping lightly around them (**Figure 7-20, Page 7-21**).
5. Clean all parts and inspect them for wear. Replace any damaged or worn parts. **See following NOTE.**

NOTE: Do not use compressed air to dry wheel bearings after cleaning.

6. Inspect the surface of the spindle shaft where the seal (6) seats. It should be clean and smooth (**Figure 7-20, Page 7-21**).

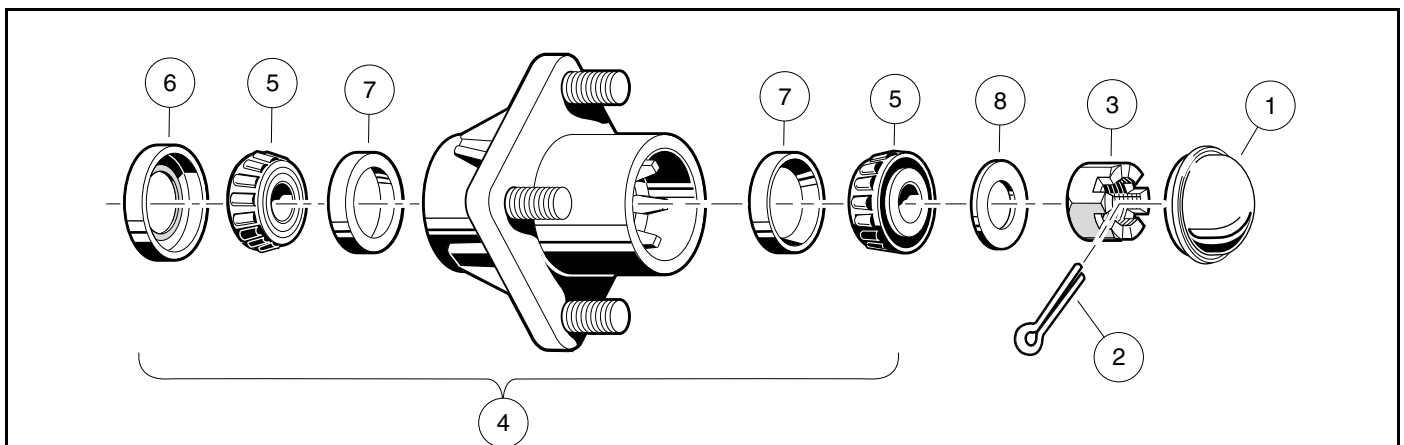

1500-18700-10273

Figure 7-20 Front Wheel Bearings and Hub

FRONT HUB AND WHEEL BEARINGS INSTALLATION

1. Pack the wheel bearings (5) and hub cavities, and lubricate cups (7) with wheel bearing grease or chassis lube. Make sure the grease is forced between the rollers (**Figure 7-20, Page 7-21**).
2. If bearing cups (7) were removed, press new ones in squarely against stops in the hub (**Figure 7-20, Page 7-21**).

NOTE: Install new cups when new bearings are installed.

3. Install the wheel bearings (5) into the hub and install a new seal (6), with the metal edge toward the hub (**Figure 7-20, Page 7-21**). See following **NOTE**.

NOTE: Apply grease around dust seal inner lip before installation.

4. Install the hub assembly (4) and flat washer (8) on the spindle and start the spindle nut (3) (**Figure 7-20, Page 7-21**).
5. Tighten the spindle nut (3) until the hub is hard to turn, then back the nut off until the hub turns freely. Install a new cotter pin (2) (**Figure 7-20, Page 7-21**). See following **WARNING** and **NOTE**.

⚠ WARNING

- **Make sure to install and bend the cotter pin. Failure to bend the cotter pin could result in the separation of the wheel hub from the spindle. Loss of vehicle control could result, causing death or severe personal injury.**

NOTE: When the cotter pins are bent, make sure they do not contact the hub or dust cap.

6. Check front wheel free play. See **Front Wheel Free Play Inspection** on page 7-21.
7. Install the dust cap (1) (**Figure 7-20, Page 7-21**).
8. Repeat the procedure for the opposite wheel.
9. Install the wheels and then finger tighten the lug nuts.
10. Lower the vehicle and finish tightening lug nuts, using a crisscross pattern, to 55 ft·lb (74.6 N·m).

⚠ DANGER

- See General Warnings on page 1-1.

⚠ WARNING

- See General Warnings on page 1-1.

GENERAL INFORMATION

NOTE: Use only Club Car approved tires when replacing tires.

Maximum tire life and good vehicle handling qualities are directly related to proper wheel and tire care.

- Keep tires properly inflated. **See Vehicle Specifications on page 2-1.**
- Keep lug nuts properly tightened.
- Keep the front end properly aligned and adjusted.

WHEELS

See General Warnings on page 1-1.

WHEEL REMOVAL

1. Slightly loosen the lug nuts on the wheel to be removed.
2. Raise the end of the vehicle from which the wheel is to be removed. Make sure the wheels are off the ground. **See WARNING “Lift only one end of the vehicle...” in General Warnings on page 1-1.**
3. Remove the lug nuts and remove the wheel.

WHEEL INSTALLATION

1. Install wheel(s), and tighten the lug nuts, using a crisscross pattern, until they are snug.
2. Lower the vehicle and finish tightening the lug nuts, using a crisscross pattern, to 65 ft·lb (88 N·m).

TIRES

See General Warnings on page 1-1.

TIRE REMOVAL

NOTE: Tire must be removed or installed from the valve stem side of the rim.

1. Remove the tire and wheel assembly from the vehicle as instructed above. **See Wheel Removal on page 8-1.**
2. Remove the valve cap and valve core and allow air to escape from the tire.
3. If possible, use a tire machine to remove the tire from the rim.
 - 3.1. If a tire machine is not available, loosen both tire beads by applying pressure to the tire side walls and pushing the tire bead away from the rim flange and into the rim well (**Figure 8-1, Page 8-2, Detail A**).
 - 3.2. With the valve stem side of the wheel up, use a tire tool to carefully start the upper bead over the edge of the rim (**Figure 8-1, Page 8-2, Detail B**). **See following CAUTION.**

CAUTION

- To avoid damage to the tire, do not use excessive force when starting the bead over the edge of the rim.
- 3.3. When top bead is free of the rim, pull the bead from the bottom side of the rim up into the upper part of the rim well. Insert the tire tool under the lower bead as shown (**Figure 8-1, Page 8-2, Detail C**) and carefully pry the lower bead over the rim flange.
 - 3.4. Once the lower bead is started over the rim flange, the tire can be removed from the rim by hand.

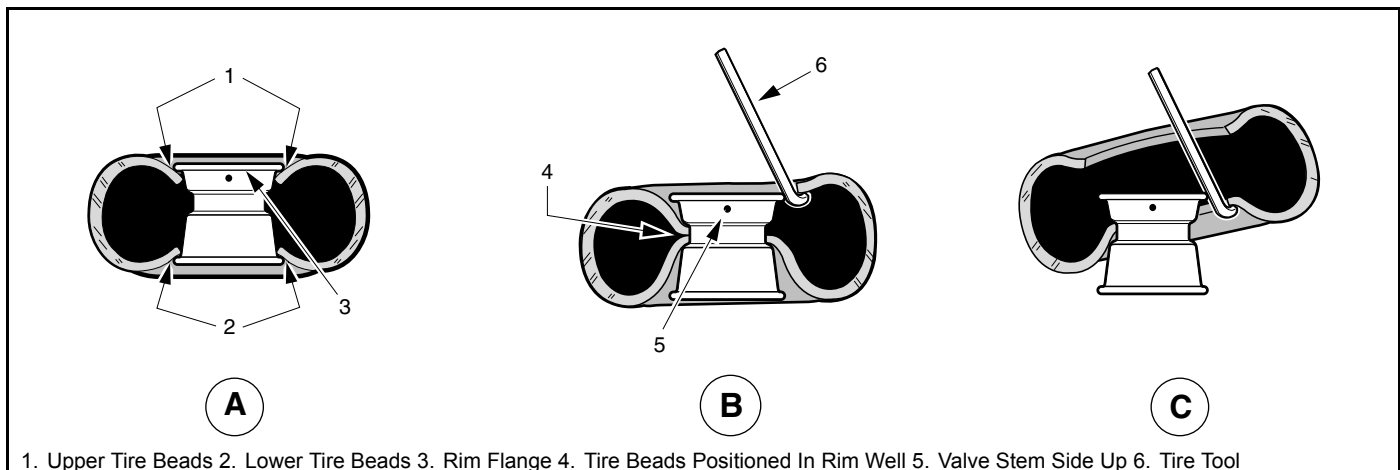

Figure 8-1 Tire Removal

TIRE REPAIR

1. Determine the location and cause of the air leak.
 - 1.1. Remove the wheel. **See Wheel Removal on page 8-1.** Inflate the tire to no more than 20 psig (138 kPa).
 - 1.2. Immerse the tire in water and then mark the point where bubbles are formed by escaping air.
 - 1.3. Determine the cause of the air leak. **See following NOTE.**

NOTE: An air leak could be due to a punctured casing, faulty valve core, improperly seated valve stem, or improperly seated tire bead.

Small holes in the casing can be plugged using a standard automotive tubeless tire repair kit available at auto supply stores.

2. When the cause of the air leak has been determined, remove tire from the rim and repair as required. **See Tire Removal on page 8-2.**

TIRE INSTALLATION

⚠ WARNING

- **While mounting or inflating tire, keep hands, fingers, etc. from exposed areas between the tire bead and rim.**

1. Clean both tire beads to remove dirt or other foreign matter.
2. Where the tire beads seat, clean the rim with a wire brush. Wipe away any debris with a clean cloth. **See following NOTE.**

NOTE: Because tubeless tires require a perfect seal in order to seat, keeping the tire and rim clean is very important.

3. Apply a liberal amount of tire-mounting lubricant (soap and water solution) to both tire beads and rim flanges.
4. Install the tire on the rim from the valve stem side. If there is no tire machine available, use a rubber mallet and tire iron.
5. Remove the valve core, and position the tire so that both beads are on the rim flange narrow bead seats.
6. Place the tire and wheel assembly against a wall in an upright position and push it against the wall while inflating the tire to the recommended pressure. **See Vehicle Specifications on page 2-1.** The three-point contact (wall, floor, and hand) will help ensure that beads snap into place and form a proper seal as the tire is inflated (**Figure 8-2, Page 8-4**). **See following WARNING.**

⚠ WARNING

- **Do not use a compressed air source with pressure over 100 psig (689.48 kPa). Due to the low pressure requirements of a small tire, over-inflation could be reached almost instantly when using a high pressure air supply. Over-inflation could cause the tire to explode, possibly resulting in personal injury.**
7. Quickly remove the air nozzle and install the valve core.
 8. Adjust air pressure in the tire to recommended pressure. **See Vehicle Specifications on page 2-1.**
 9. Immerse the wheel and tire assembly in water to make sure there are no leaks.

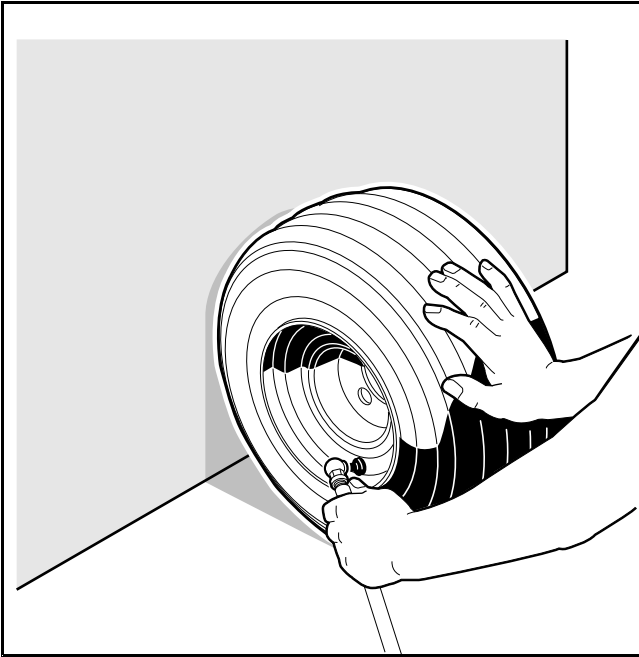

Figure 8-2 Inflate Tire

⚠ DANGER

- See General Warnings on page 1-1.

⚠ WARNING

- See General Warnings on page 1-1.

GENERAL INFORMATION

The rear suspension and powertrain of the vehicle move independently from the vehicle frame. It consists of two leaf springs controlled by two shock absorbers mounted between the springs and the vehicle frame.

SHOCK ABSORBERS

See General Warnings on page 1-1.

SHOCK ABSORBER INSPECTION AND REMOVAL

1. Check shock absorbers (19) for damage or fluid leakage at the point where the shaft enters the shock absorber body. Replace damaged or leaking shock absorbers (**Figure 9-1, Page 9-1**) and (**Figure 9-4, Page 9-4**).
2. To remove a shock absorber, remove the nut (1), cup washers (4), and rubber bushings (3) from the stem at the top of the shock absorber.
3. Remove lower mounting hardware (1, 3, and 4) on shock absorber lower mount.
4. Compress the shock absorber to remove it.

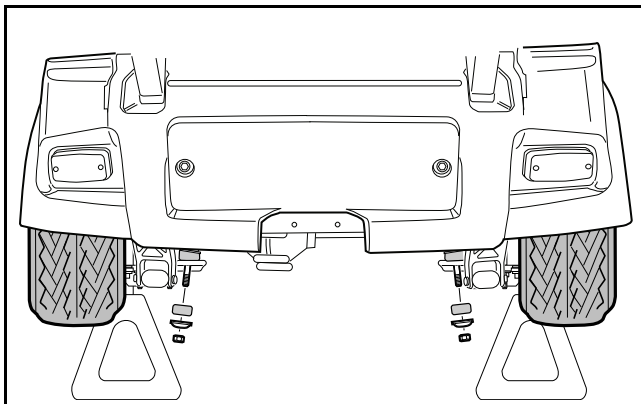

2860
Figure 9-1 Shock Absorber Removal

SHOCK ABSORBER INSTALLATION

NOTE: When installing shock absorbers, make sure front shocks have identical part numbers and rear shocks have identical part numbers.

NOTE: Tighten 3/8 hex nut at shock absorber until shock absorber cushions are approximately the same diameter as the retainers. Do not over tighten.

1. On the upper and lower shock absorber mounting stems, tighten the nut (1) until the rubber bushing (3) expands to the size of the cup washer (4).

MULTI-LEAF SPRINGS

See General Warnings on page 1-1.

MULTI-LEAF SPRING REMOVAL

1. Disconnect the battery cables and either discharge the controller or disconnect the spark plug wire(s). **See Disconnecting the Batteries – Electric Vehicles, Section 1, Page 1-4. See Disconnecting the Battery-Gasoline Vehicles on page 1-5.**
2. Loosen, but do not remove, lug nuts on tire and wheel assembly on the side from which the spring is to be removed. Place chocks at the front wheels and lift the rear of the vehicle with a chain hoist or floor jack. Position jack stands under the frame crossmember between the spring mount and the side stringer, just forward of each rear wheel. Lower the vehicle to let the jack stands support the vehicle (**Figure 9-2, Page 9-3**). **See following WARNING.**

⚠ WARNING

- **Lift only one end of the vehicle at a time. Use a suitable lifting device (chain hoist or hydraulic floor jack) with 1000 lb (454 kg) minimum lifting capacity. Do not use lifting device to hold vehicle in raised position. Use approved jack stands of proper weight capacity to support the vehicle and chock the wheels that remain on the floor. When not performing a test or service procedure that requires movement of the wheels, lock the brakes.**
3. Place a floor jack under the transaxle differential casing to support (but not lift) the drivetrain. Raise it just enough to relieve tension on the shock absorbers without compressing them.
 4. Remove the tire and wheel assembly on the side from which the spring is to be removed.
 5. Remove the bow-tie pin (1) and the clevis pin (2) at the brake lever and brake cable connection and pull the clevis (3) away from the lever (**Figure 9-3, Page 9-3**). Detach the brake cable from the shock mount bracket (**Figure 9-2, Page 9-3**).
 6. Remove the nut (1), cup washers (4), and rubber bushings (3) from the lower mounting stem of the shock absorber (**Figure 9-4, Page 9-4**).
 7. Remove the nuts (7) and the U-bolt (9) securing the spring to the shock mounting bracket (16). Remove the shock mount bracket (6), angle bracket (8), and the U-bolt (**Figure 9-4, Page 9-4**).
 8. Remove the nut (11) and bolt (17) attaching the rear spring to the lower end of the shackle brackets (13).
 9. Remove the nut (11) and bolt (17) attaching the front of the spring to the vehicle frame and remove the spring.
 10. Inspect the bushings and spacers in the spring eyes and replace them if they are worn or damaged.

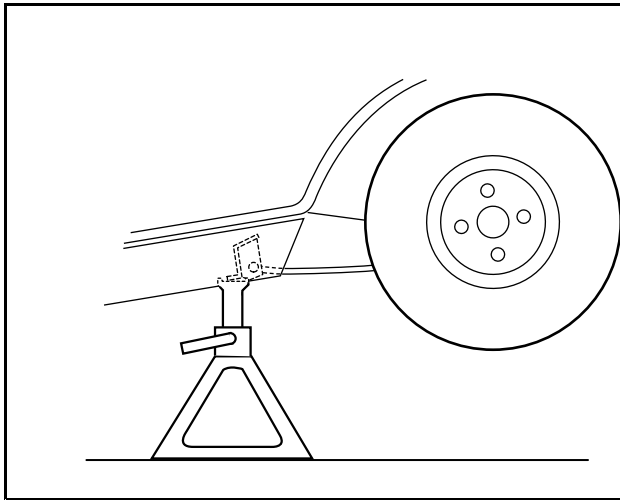

2600-30000-10369

Figure 9-2 Support Vehicle on Jack Stands

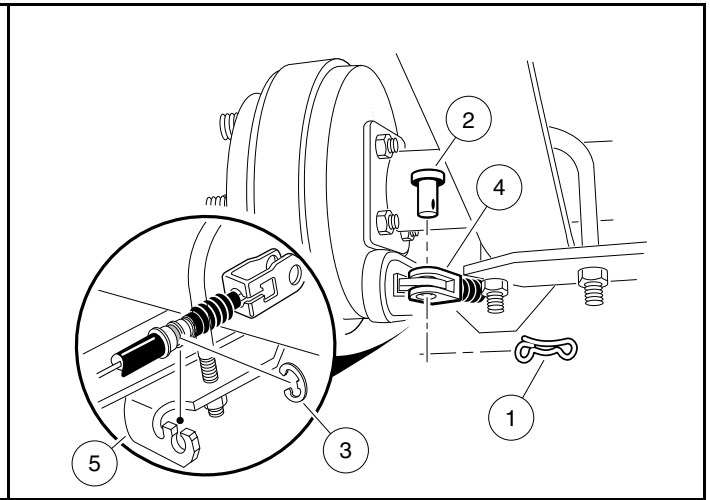

1400-18100-10243

Figure 9-3 Disconnect Brake Cable

MULTI-LEAF SPRING INSTALLATION

NOTE: Tighten bolt (11) after clamp from brake cable has been positioned between nut and frame component.

1. Install the bushings and spacers in the spring eyes. **See following CAUTION.**

▲ CAUTION

- **When positioning the spring on the transaxle, be sure to insert the locating bolt on the spring in the locating hole in the transaxle saddle.**
2. Install the nut (11) and bolt (17) attaching the front of the spring to the vehicle frame and install the spring.
 3. Install the nut (11) and bolt (17) attaching the rear spring to the lower end of the shackle brackets (13).
 4. Install the nuts (7) and the U-bolt (9) securing the spring to the shock mounting bracket (16). Install the shock mount bracket (6), angle bracket (13) and the U-bolt.
 5. Tighten the nuts (7) on the U-bolt (9) to 22 to 27 ft·lb (30 to 37 N·m).
 6. Install the nut (1), cup washers (4), and rubber bushings (3) to the lower mounting stem of the shock absorber
 7. Tighten nylon lock nuts (11) on spring mounting bolts (17) to 17 to 20 ft·lb (24 to 28 N·m) **(Figure 9-4, Page 9-4).**
 8. Tighten the nuts (1) until the rubber bushing (3) expands to the size of the cup washer (4).
 9. Connect the battery cables. **See Connecting the Batteries – Electric Vehicles, Section 1, Page 1-4. See Connecting the Battery-Gasoline Vehicles on page 1-5.**

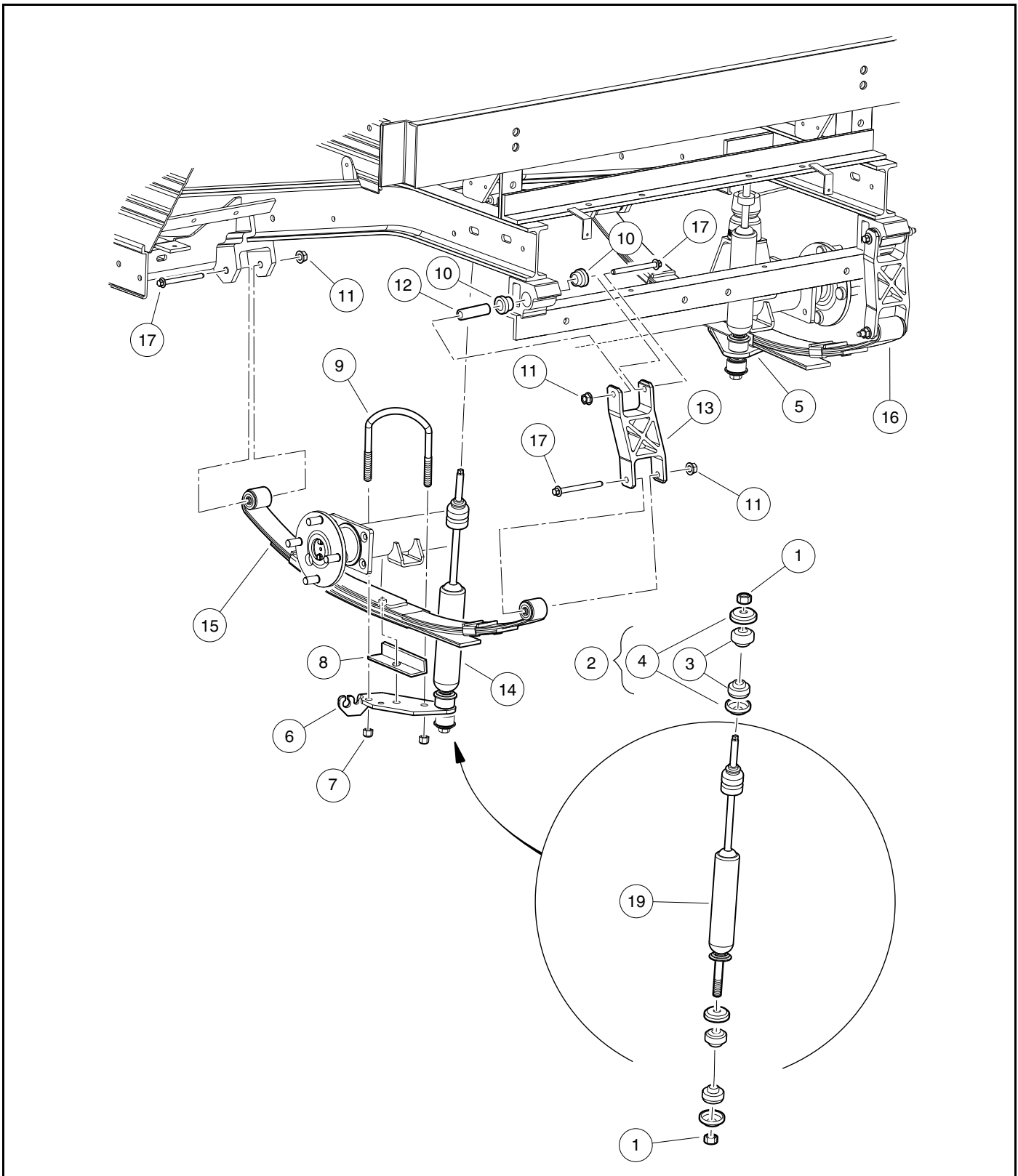

2987

Figure 9-4 Rear Suspension Assembly and Mounting

GENERAL INFORMATION

See **General Warnings** on page 1-1.

To ensure trouble-free vehicle performance, it is very important to follow an established preventive maintenance program (regularly scheduled service). Regular and consistent vehicle maintenance can prevent vehicle down-time and expensive repairs that result from neglect. Any vehicle not functioning correctly should be removed from use until it is properly repaired. This will prevent further damage to the vehicle and avoid the possibility of injury due to unsafe conditions.

Contact your local authorized distributor/dealer to perform all repairs and semiannual and annual periodic service.

PRE-OPERATION AND DAILY SAFETY CHECKLIST

Each Club Car vehicle has been thoroughly inspected and adjusted at the factory; however, upon receiving your new vehicle(s), you should become familiar with its controls, indicators, and operation. Carefully inspect each vehicle to ensure that it is in proper working condition before accepting delivery.

Use the following checklist as a guide to inspect the vehicle. This checklist should be used daily to ensure that the vehicle is in proper working condition and in conjunction with the Performance Inspection on page 10-1 and the Periodic Service Schedules on page 10-4. Any problems should be corrected by a Club Car distributor/dealer or a trained technician.

- **General:** All the parts should be in place and properly installed. Be sure that all nuts, bolts, and screws are tight. On gasoline vehicles, check all hose clamps for tight fit as well as the starter belt for tightness.
- **Safety and information decals:** Check to ensure that all safety and information decals are in place.
- **Tires:** Visually inspect for wear, damage, and proper inflation on a daily basis. **See Vehicle Specifications on page 2-1.**
- **Battery(ies):** Check electrolyte to ensure that it is at its proper level (**Figure 14-3, Page 14-10**). Check battery posts. Wires should be tight and free of corrosion. On electric vehicles, charge batteries fully before first use of vehicle.
- **Charger cord and plug (electric vehicles):** Visually inspect for cracks, loose connections, and frayed wiring.
- **Battery (gasoline vehicles):** Check battery posts. Wires should be tight and free of corrosion and battery should be fully charged.
- **Engine (gasoline vehicles):** Check for proper engine oil level. **See Engine Oil – Gasoline Vehicle on page 22-2.** Inspect air intake for blockage.
- **Fuel (gasoline vehicles):** Check fuel level. **See Fueling Instructions – Gasoline Vehicle on page 23-24.** Check fuel tank, fuel injector, lines, cap, and pump for fuel leakage on a daily basis.
- **Performance Inspection:** Inspect as instructed. **See Performance Inspection on page 10-1.**

WARNING

- **Be sure the plastic has been removed from the seat bottom before operating the vehicle. Failure to do so can result in a fire, property damage, personal injury, or death.**

PERFORMANCE INSPECTION

After you have familiarized yourself with the vehicle controls and have read and understood the driving instructions, take the vehicle for a test drive.

Use the following checklist, in conjunction with the Pre-Operation and Daily Safety Checklist, as a guide to inspect the vehicle and check daily for proper operation. Any problems should be corrected by a Club Car distributor/dealer or a trained technician.

All Vehicles

- **Forward/Reverse control:** Check for proper operation.
- **Brakes:** Be sure the brakes function properly. When brake pedal is fully pressed under moderate pressure, it should not go more than halfway to the floor, and vehicle should come to a smooth, straight stop. If the brake pedal goes more than halfway to the floor, or if the vehicle swerves or fails to stop, have the brake system checked and adjusted as required. Brake adjustment must be maintained so that the brake pedal cannot be pressed to the floor under any circumstance.
- **Park brake:** When latched, the park brake should lock the wheels and hold the vehicle stationary (on an incline of 20% or less). It should release when either the accelerator or brake pedal is pressed.
- **Reverse buzzer:** The reverse buzzer should sound as a warning when the Forward/Reverse handle or switch is in the REVERSE position.
- **Steering:** The vehicle should be easy to steer and should not have any play in the steering wheel.
- **General:** Listen for any unusual noises such as squeaks or rattles. Check the vehicle ride and performance. Have a Club Car distributor/dealer or a trained technician investigate anything unusual.

Electric Vehicles

- **Accelerator:** With the key switch in the ON position and the Forward/Reverse switch in the FORWARD position, as the accelerator pedal is pressed, the motor should start and the vehicle should accelerate smoothly to full speed. Club Car vehicles operate at reduced speed in reverse. When the pedal is released, it should return to the original position and the motor should rotate freely or go into motor braking mode. **See Pedal Up Motor Braking below.**
- **Walk Away Braking:** With the vehicle parked on level ground and the park brake disengaged, place the Run/Tow switch in the RUN position and attempt to push the vehicle. Motor braking should engage and limit rolling to no more than 1 to 3 mph (1.6 to 4.8 km/h) with the Forward/Reverse switch in any position. When walk away motor braking is engaged, the reverse buzzer should emit a distinct pattern of beeps.
- **Pedal Up Motor Braking:** Accelerate the vehicle to full speed and then release the accelerator pedal. Motor braking should quickly and smoothly slow the vehicle. Motor braking will disengage when vehicle slows to the programmed speed for IQ Plus vehicles. This feature is programmable for IQ Plus vehicles. Contact your local Club Car dealer/distributor to inquire about this adjustable feature.
- **Pedal Down Motor Braking:** Accelerate down an incline with the accelerator pedal pressed. When the vehicle reaches maximum programmed speed, motor braking should engage and limit the vehicle to its maximum programmed speed. On very steep grades, the vehicle may slightly exceed its maximum programmed speed, requiring use of the brake pedal.

Gasoline Vehicles

- **Accelerator for pedal-start vehicles:** With the key switch in the ON position and the Forward/Reverse handle in the FORWARD position, as the accelerator pedal is pressed, the engine should start and the vehicle should accelerate smoothly to full speed. When the pedal is released, it should return to the original position and the engine should stop.
- **Accelerator for key-start vehicles:** After starting the engine with the key switch and placing the Forward/Reverse handle in the FORWARD position, the vehicle should accelerate smoothly to full speed as the accelerator pedal is pressed. When the accelerator pedal is released, it should return to the original position and the engine should idle.
- **Governor:** Check maximum speed of the vehicle on a level surface. Refer to Vehicle Specifications beginning on page 2-4 for the rated speed of the vehicle.

MAINTENANCE

See General Warnings on page 1-1.

To ensure trouble-free vehicle performance, it is very important to follow an established preventive maintenance program. Regular and consistent vehicle maintenance can prevent vehicle downtime and expensive repairs that can result from neglect. Use the Pre-Operation and Daily Safety Checklist on page 10-1 and the following *Periodic Service Schedules* and *Periodic Lubrication Schedules* to keep the vehicle in proper working condition.

Any vehicle not functioning correctly should be removed from use until it is properly repaired. This will prevent further damage to the vehicle and avoid the possibility of injury due to unsafe conditions.

Contact your local Club Car distributor/dealer to perform all repairs and semiannual and annual periodic service.

▲ WARNING

- If any problems are found during scheduled inspection or service, do not operate the vehicle until repairs are made. Failure to make necessary repairs can result in fire, property damage, severe personal injury, or death.
- Only trained technicians should service or repair the vehicle or battery charger. Anyone doing even simple repairs or service should have knowledge and experience in electrical and mechanical repair. The appropriate instructions must be used when performing maintenance, service, or accessory installation.
- Do not work on vehicle powertrain or under the cargo bed when it is loaded.
- Do not wear loose clothing or jewelry, such as rings, watches, chains, etc., when servicing the vehicle.
- Turn the key switch to OFF, remove the key, place the Forward/Reverse handle or switch in the NEUTRAL position, and chock tires prior to servicing.
- Do not close bed until all persons are clear of the bed area. Lower the bed gently, keeping entire body clear. Do not drop the bed. Failure to follow these instructions can result in severe personal injury.

Electric vehicles:

- Hot! Do not attempt to service hot motor. Attempting to do so can cause severe burns.
- To avoid unintentionally starting the vehicle, disconnect the batteries and discharge the controller. See *Disconnecting the Batteries – Electric Vehicles* on page 1-4.

Gasoline vehicles only:

- Moving parts: Do not attempt to service gasoline vehicle while the engine is running.
- Hot! Do not attempt to service hot engine or exhaust system. Failure to heed this warning can result in severe burns.
- To avoid unintentionally starting the vehicle, disconnect battery and spark plug wire. See *Disconnecting the Battery-Gasoline Vehicles* on page 1-5.
- Frame ground – Do not allow tools or other metal objects to contact frame when disconnecting batteries or other electrical wiring. Never allow a positive wire to touch the vehicle frame, engine, or other metal component.

PERIODIC SERVICE SCHEDULES

See General Warnings on page 1-1.

⚠ WARNING

- Service, repairs, and adjustments must be made per instructions in the maintenance and service manual.

NOTE: If the vehicle is constantly hauling heavy loads or hauling a trailer, these preventive maintenance procedures should be performed more often than recommended in the Periodic Service Schedule.

Both the Periodic Service Schedules and the Periodic Lubrication Schedules must be followed to keep vehicle in optimum operating condition.

PERIODIC SERVICE SCHEDULE – ELECTRIC VEHICLES		
REGULAR INTERVAL	SERVICE	
Daily service by owner	Pre-Operation and Daily Safety Checklist	See Pre-Operation and Daily Safety Checklist on page 10-1.
	Performance Inspection	See Performance Inspection on page 10-1.
	Batteries	Charge batteries (after each daily use only).
Weekly service by owner	Batteries (For vehicles NOT equipped with the Single-Point Watering System)	Check electrolyte level. Add water if necessary. See page 14-10.
Monthly service by owner or trained technician	Batteries (For vehicles equipped with the Single-Point Watering System). Water monthly or according to the established watering interval.	Water the batteries. Observe that water flow occurs and no water overflows from any cell. See Battery Care – Vehicles Equipped with the Single-Point Watering System (SPWS) on page 14-8.
	Batteries	Wash battery tops and clean terminals with baking soda/water solution.
	Tires	Check air pressure and adjust if necessary. See Vehicle Specifications – Electric Vehicles on page 2-1.
	General vehicle	Wash battery compartment and underside of vehicle.
Initial (one-time) inspection by owner or trained technician after six weeks of use	Batteries (For vehicles newly equipped with the SPWS)	For vehicles newly equipped with the SPWS, manually check battery electrolyte levels of all cells to verify correct valve operation. See page 14-9.

TABLE CONTINUED ON NEXT PAGE

PERIODIC SERVICE SCHEDULE – ELECTRIC VEHICLES		
REGULAR INTERVAL	SERVICE	
Semiannual service by trained technician only (or every 50 hours of operation, whichever comes first)	Brake system	Check brake shoes; replace if necessary or adjust as required.
		Check brake cables for damage; replace if necessary.
		Check brake cable equalizer adjustment; adjust if necessary.
	Electrical wiring and connections	Check for tightness and damage.
	Front wheel alignment and camber	Check and adjust as required. See Steering and Front Suspension section in the maintenance and service manual.
Annual service by trained technician only (or every 100 hours of operation, whichever comes first)	Motor Controller Output Regulator (MCOR)	Check for loose hardware, cracks, or other damage.
	Batteries (For vehicles equipped with the SPWS)	Manually check battery electrolyte levels of all cells to verify correct valve operation. See page 14-9.
	Batteries	If batteries are not performing as expected, see the Batteries section in the maintenance and service manual.
	Safety decals	Check safety decals. Replace if damaged or illegible.

PERIODIC SERVICE SCHEDULE – GASOLINE VEHICLES		
REGULAR INTERVAL	SERVICE	
Daily service by owner	Pre-Operation and Daily Safety Checklist	See Pre-Operation and Daily Safety Checklist on page 10-1.
	Performance Inspection	See Performance Inspection on page 10-1.
Monthly service by owner or trained technician	Engine	Check engine oil level; change if necessary. See Periodic Lubrication Schedules on page 10-7. Dispose of used oil properly.
		Check engine cooling air intake; visually inspect unshrouded area around engine exhaust for grass and debris, and clean if necessary.
	Tires	Check air pressure and adjust if necessary. See Vehicle Specifications – Gasoline Vehicles on page 2-4.
	General vehicle	Wash engine compartment and underside of vehicle. Do not wash engine when hot.

TABLE CONTINUED ON NEXT PAGE

PERIODIC SERVICE SCHEDULE – GASOLINE VEHICLES		
REGULAR INTERVAL	SERVICE	
Semiannual service by trained technician only (or every 50 hours of operation, whichever comes first)	Battery	Clean terminals and wash dirt from casing.
	Front wheel alignment and camber	Check and adjust if necessary. See Steering and Front Suspension section in the maintenance and service manual.
	Electrical wiring and connections	Check for tightness and damage.
	Brake system	Check brake shoes; replace if necessary or adjust as required.
		Check brake cables for damage; replace as required.
		Check brake cable equalizer adjustment; adjust if necessary.
Annual service by trained technician only (or every 100 hours of operation, whichever comes first)	Engine	Check for leaks around gaskets, fill plugs, etc.
		Inspect, clean and gap spark plug; replace if necessary.
	Engine air intake system	Check air filter element; clean or replace if necessary.
		Check clamps for tightness; check hose for cracks.
	General vehicle	Check for loose hardware and tighten if necessary.
	Safety decals	Check safety decals. Replace if damaged or illegible.
Two-year service by trained technician only.	Engine	Check and adjust valve lash as needed.

WARNING

- If any problems are found during scheduled inspection or service, do not operate the vehicle until repairs are made. Failure to make necessary repairs can result in fire, property damage, severe personal injury, or death.

PERIODIC LUBRICATION SCHEDULES

PERIODIC LUBRICATION SCHEDULE – ELECTRIC VEHICLES			
REGULAR INTERVAL	SERVICE	LUBRICATION POINTS	RECOMMENDED LUBRICANT
Semiannually by owner or trained technician (or every 50 hours of operation, whichever comes first)	Brake pedal shaft bearings	1	Dry Moly Lube (CC PN 1012151)
	Brake linkage and pivots	2	Dry Moly Lube (CC PN 1012151)
	Accelerator pivot rod supports	3	Dry Moly Lube (CC PN 1012151)
	Brake slides	4	Dry Moly Lube (CC PN 1012151)
	Front suspension	5	Chassis Lube – EP NLGI Grade 2
Annually by trained technician only (or every 100 hours of operation, whichever comes first)	Transaxle: Check/fill to plug level.	6	22 fl-oz (0.67 L) SAE 30 WT. API Class SE, SF, SG Oil (or higher)
	Inspect front wheel bearings (Repack as necessary)	7	Chassis Lube – EP NLGI Grade 2

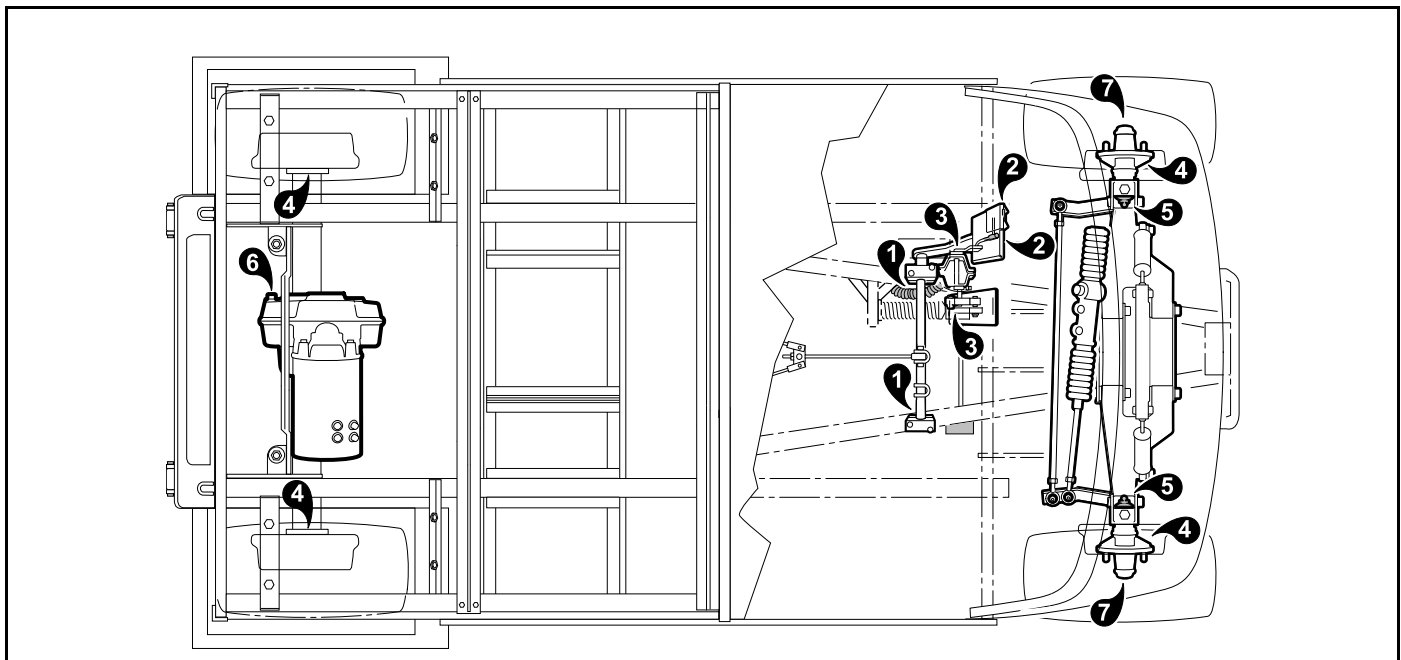

2822

Figure 10-1 Lubrication Points – Electric Vehicles

PERIODIC LUBRICATION SCHEDULE – GASOLINE VEHICLES			
REGULAR INTERVAL	SERVICE	LUBRICATION POINTS	RECOMMENDED LUBRICANT
Semiannually by owner or trained technician (or every 50 hours of operation, whichever comes first)	Brake pedal shaft bearings	1	Dry Moly Lube (CC PN 1012151)
	Brake linkage and pivots	2	Dry Moly Lube (CC PN 1012151)
	Accelerator pivot rod supports and shifter cable pivots	3	Dry Moly Lube (CC PN 1012151)
	Front suspension	4	Chassis Lube (EP NLGI Grade 2)
	Brake slides	5	Dry Moly Lube (CC PN 1012151)
Annually by trained technician only (or every 100 hours of operation, whichever comes first)	Transaxle: Check/fill to plug level	6	67.6 fl-oz (2 L) SAE 80W-90 API Class GL-5
	Inspect front wheel bearings (Repack as necessary)	7	Chassis Lube – EP NLGI Grade 2
First change 100 hours – additional change every 200 hours of operation or annually, whichever comes first	Change engine oil	8	40.5 fl-oz (1.2 L) 10W-30 or 5W-30 grade SE or higher See also Figure 22-3, Page 22-5.

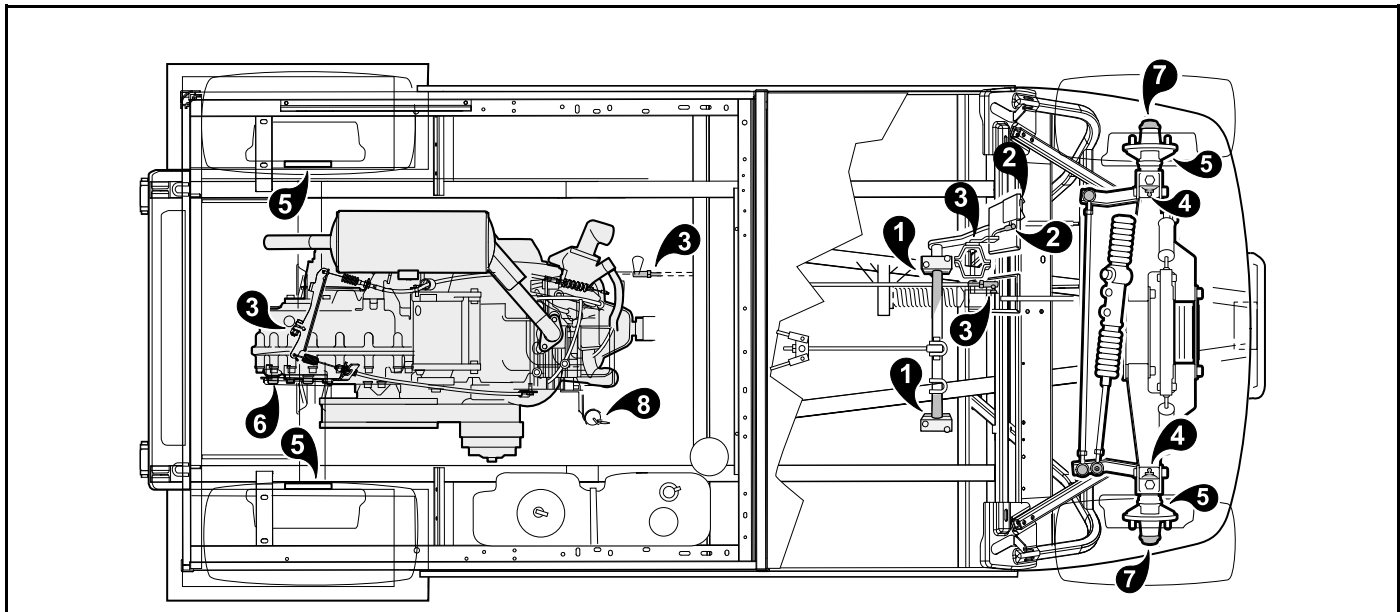

2823

Figure 10-2 Lubrication Points – Gasoline Vehicles

⚠ DANGER

- See General Warnings on page 1-1.

⚠ WARNING

- See General Warnings on page 1-1.

NOTE: The information presented in this section addresses the following:

- The Controller Diagnostic Tool (CDT) handheld programmer which replaced the IQDM series 2 handset.
- How to use the CDT to troubleshoot the vehicle and to adjust controller parameters that affect vehicle behavior.

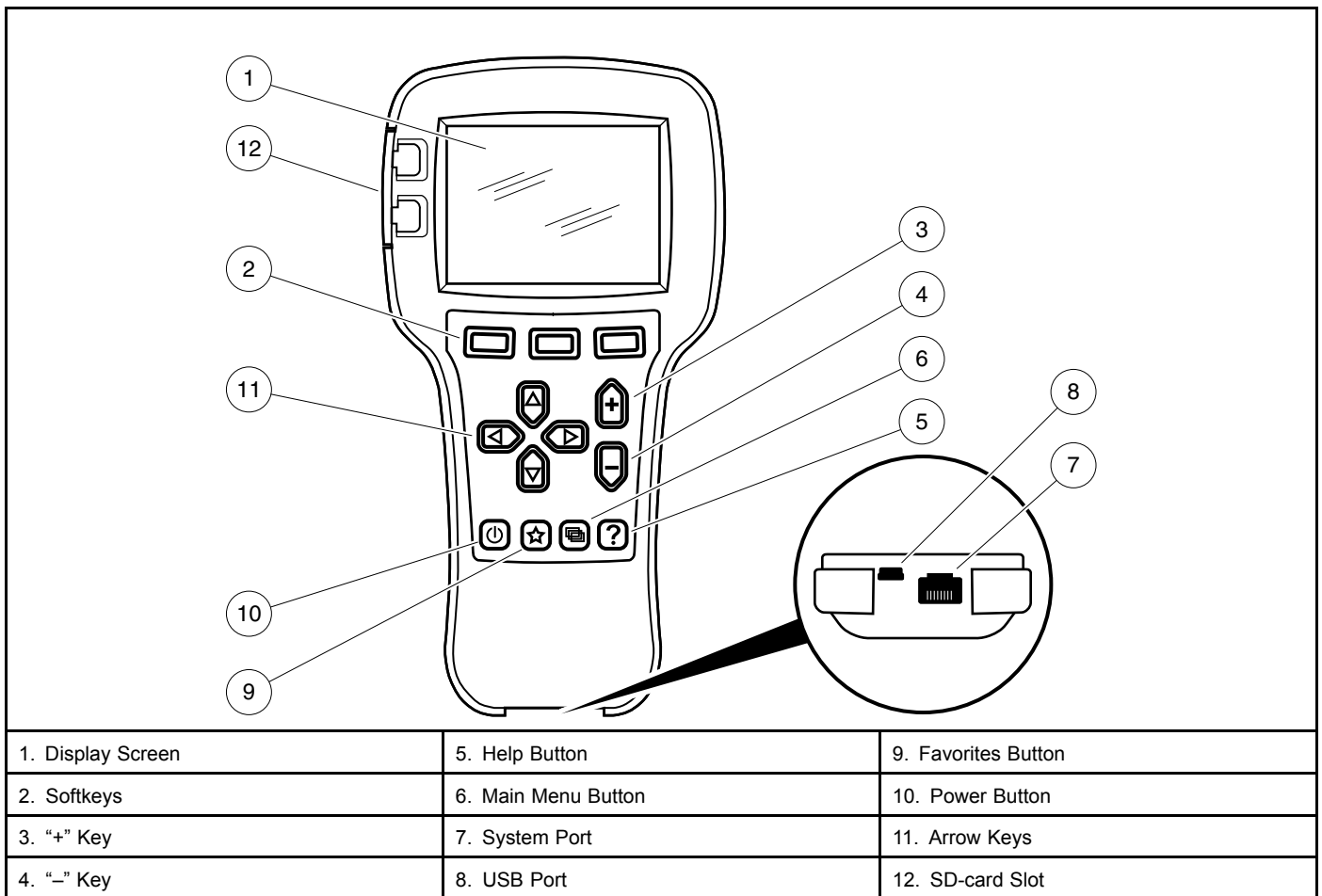

3115

Figure 11-1 CDT Overview

GENERAL INFORMATION

The CDT is used to adjust and save parameter settings of the controller, monitor real-time data, and perform diagnostics and troubleshooting of the electric vehicle.

FEATURES

- **Batteries:** Two AA batteries provide power for the CDT's real-time clock and they allow for use of the CDT when not connected to a vehicle.
- **Convenient parameter adjustment:** You can easily adjust a wide range of parameters to customize vehicle performance. These settings can then be saved as a unique .cpf (Cab Provisioning Format) file and stored. Multiple .cpf files can be stored and restored as needed.
- **Diagnostics and troubleshooting:** Existing faults as well as all the accumulated faults in the system's fault history file are listed in clear language. Suggestions for clearing each fault are also provided.
- **Help function:** Help screens give descriptions of adjustable parameters, monitored variables, and faults.
- **PC interface:** Files can be downloaded from a PC (onto an Secure Digital (SD) card or into the programmer directly through its USB connector) for installation into the controller.
- **Plot and Log:** The plot and log programs allow you to look at variables over time, either in graphical format or as data files you can upload in a spreadsheet program, such as Microsoft Excel.
- **Real-time monitoring:** Values of monitored data variables are displayed in easy-to-read formats.
- **SD-card support:** An SD card provides additional memory capacity. This is where any screenshots you take will be stored. SD cards can be used to deliver software upgrades, and can be used in multiple programmers to install identical software.
- **Softkeys:** Three versatile softkeys provide multiple functions, depending on context.
- **Update:** The handheld programmer can update its own software.

PLUGGING THE CDT INTO THE VEHICLE

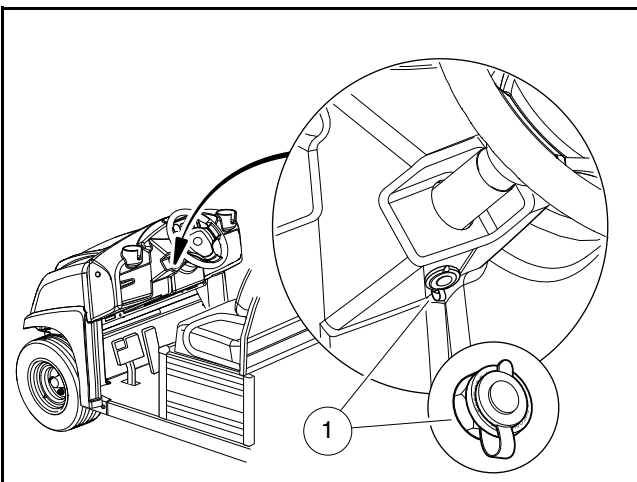

2977

Figure 11-2 Communication Port Under Instrument Panel

1. Connect one end of the cable to the port located on the bottom of the CDT.
2. Connect the cable adaptor to the CDT cable.
3. Find the communication port on the vehicle (**Figure 11-2, Page 11-2**).
4. Remove the dust cap from the communication port.
5. Align the keyed portion of the plug with the communication port and insert plug into port.

INTRODUCTORY DISPLAY

Immediately after the CDT is connected to the vehicle, it begins loading controller information. During this time, the loading status is shown as a percentage, the CDT's software version is given, and status/information icons appear in the upper right corner. Once loading is complete, the screen displays the Main Menu.

NOTE: *If the Power button is used to turn ON the handset and the handset is not connected to a vehicle, the message "No System Detected" will be displayed.*

In the event that the handset does not display any information, or the screen is difficult to read, refer to the CDT troubleshooting procedures. **See CDT Troubleshooting on page 11-27.**

QUICK REFERENCE GUIDE – IQ PLUS WITH QUIQ CHARGER

OPERATION:	
Change screen contrast for better viewing by selecting the following: HPP Settings, Backlight	
Preset Favorites: Select a frequently viewed screen, press “Add to” softkey, highlight “Favorites”, press “Select” softkey.	
CONTROLLER FAULTS:	
Anti Tamper: If car not equipped with Visage, make sure Control Mode is set to zero (0).	Main Weld: Replace solenoid, if it doesn't correct fault of car running at half speed, check accessory wiring.
Circuit Breaker Open: Check wiring, replace circuit breaker.	Motor Stall: If car moves freely, issue not with vehicle, operator error.
Current Sense Fault: Replace controller.	Open ARM (Armature): Check motor brushes, A1 and A2 motor wires at controller and check controller.
FLD Missing: Check in order; orange or blue wire broke or disconnected at motor/controller, short in motor. If good, replace controller.	Overage Voltage: Controller reads 72 volts or more, it's an effect, not a cause. See other faults that accompany OV.
HPD: Check throttle %. If at zero (0), driver issue.	Pre-Charge Resistor: Replace controller.
HW Failsafe: Replace controller.	PROC/Wiring: Check for water in FNR switch, corroded contacts of switch inside FNR, and/or replace switch.
Incorrect Password: Incorrect code being entered into controller, check code A,B,C.	Relay Coil: Check wiring. If OPEN, replace relay.
Low Battery Voltage: Check Battery Voltage Under a Load less than 34 volts, could be an effect, not a cause.	Relay DNC: Check wiring, replace relay.
M-Shorted: Replace controller.	Relay Driver Off: Replace controller.
M (Main) Coil Open: Broken or disconnected coil wire (B+ or B-), a defective solenoid coil. Replace solenoid.	Relay Driver On: Replace controller.
Main Driver Off: Replace controller.	Relay Welded: Replace relay.
Main Driver On: Replace controller.	Speed Sensor: Check connection, replace speed sensor.
Main Driver Overcurrent: Replace controller.	Thermal (TEMP) Cutback: Controller heatsink rises above 185 °F . (above 85 °C), increased resistance causes issue.
Main Dropout: Solenoid or any component before it in circuit could be at fault. Check components from key switch to solenoid and connections.	Throttle Fault: Possible MCOR failure, perform additional diagnostic if car is running.
Main Dropout 2: Effect more than the cause, see other faults that accompany Main Dropout 2	
WHEN CDT IS NOT COMMUNICATING WITH CONTROLLER, CHECK THE FOLLOWING COMPONENTS:	
The main connection port is corroded. Plug directly into the controller.	The battery pack voltage is below 32 volts. Check pack voltage to see if it is above 32 volts.
The AC cord is plugged into an AC outlet for more than 10 minutes. Unplug AC Cord.	Gray wire (pin # 4) to controller (24-pin connector) is loose or broken.
The charger interlock circuit has failed. Check for voltage on Light Blue wire in pin 2 of 24-pin connector.	Sonic weld 1 or 12 in Tow switch circuit failed (wire harnesses vary; see wiring schematic for that model vehicle)
Run/Tow switch is in “Tow” position. Switch to “Run” position.	The controller has failed.
The Tow circuit has failed. Check 15 Amp ATC fuse in fuse block, Tow switch, 24-pin connector, and wire harness.	

SYSTEM INFO

The *System Info* menu is accessed by using the arrow keys to highlight *System Info* and pressing the *Select* softkey to activate the menu.

The *System Info* selection displays information pertaining to the controller. The information provided from this menu selection includes:

MODEL NUMBER

Displays the model number of the controller.

SERIAL NUMBER

Displays the serial number of the controller.

HARDWARE VERSION

Displays the controller hardware version. **See following NOTE.**

PROTOCOL VERSION

Displays the controller protocol version.

PARAM BLOCK VERSION

Displays a number that represents the default parameter settings at time of manufacture.

MFG DATE CODE

Displays the date the controller was manufactured.

OS VERSION

Displays the controller operating system software version. **See following NOTE.**

SM VERSION

Displays the version number of the Start Manager software in the controller.

VCL APP VERSION

Displays the version number of the Vehicle Control Language application software in the controller.

PARAMETERS

The *Parameters* menu is accessed by using the arrow keys to highlight *Parameters* and pressing the *Select* softkey to activate the menu.

The *Parameters* menu is where you can view and modify the settings of the controller's adjustable parameters. Navigate through this complex menu using the arrow keys, +/- keys, and softkeys. **The parameters displayed will depend on the access level of the handset.**

Be aware when changing parameter settings, the new values replace the earlier values. If you make adjustments that you don't like, and wish you could return to the earlier values, you cannot do this unless you have written down those earlier settings (which is unlikely) or unless you have saved them. To save your parameter settings, use the "Save .cpf File" function in the Programming menu; see Plot & Log on page 11-26. Your parameter settings will then be saved in a .cpf file. You can save as many .cpf files as you desire, and you can create unique names for them. If you prefer, each .cpf can automatically be given a name consisting of the date and time when it was created; see the "Text for save as" item in the HHP (Handheld Programmer) Settings menu; see Plot & Log on page 11-26. For information on creating names, see **Using the Keyboard** in the CDT Owner's Manual.

SETTINGS

M1/M2 Speed

NOTE: M1 refers to "Mode 1" and M2 refers to "Mode 2." To activate Mode 2 in the CDT, Code A, Code B and Code C must be entered. **See Code A, Code B, and Code C on page 11-9.** All settings in Mode 2 are programmed with the same procedures as Mode 1.

The vehicle's top speed can be changed by selecting values 1 through 4. **See chart below.**

SPEED SETTING	VEHICLE SPEED
1	8.0 mph (12.9 km/h)
2	12 mph (19.3 km/h)
3	15 mph (24.1 km/h)
4	17 mph (27.4 km/h)

A vehicle programmed for speed setting 4 does not conform to ANSI Z130.1 – American National Standard for Golf Cars – Safety and Performance Specifications because it is capable of speeds in excess of 15 mph (24.1 km/h). For more information on this feature, contact your local Club Car distributor or dealer.

M1/M2 Fast Accel

M1/M2 fast accel (fast acceleration) is an option that can be enabled or disabled. With *fast accel* turned on, the vehicle will accelerate at a noticeably faster rate. With this feature turned off, the vehicle speed will gradually increase, even if the accelerator is quickly pressed to the floor. Turn the feature on or off by pressing "+" or "-" on the change value button.

M1/M2 Pedal Up

Three options exist for *M1/M2 pedal up* (motor braking). On a level surface, when the accelerator pedal is released, motor braking will slow the vehicle to a stop when pedal up motor braking is enabled (option 1 or 2). If pedal up motor braking is disabled (option 0), the vehicle will coast to a stop when the pedal is released.

When the vehicle is going down an incline, and the accelerator pedal is released motor braking will slow the vehicle to a controlled speed directly proportional to the slope of the incline when pedal up motor braking is enabled (option 1 or 2). If pedal up motor braking is disabled (option 0), the vehicle will coast up to the programmed top speed when the pedal is released.

Change the settings of the M1/M2 Pedal Up by pressing "+" or "-" on the change value button.

M1/M2 PEDAL UP SETTING	MODE	OPERATION DESCRIPTION
0	Off	Pedal up motor braking is disabled
1	Mild pedal up	Mild pedal up motor braking
2	Aggressive pedal up	Aggressive pedal up motor braking

M1/M2 Speed Cal

The *M1/M2 speed cal* (speed calibration) menu item allows the user to fine tune the vehicle speed. This feature cannot be used to increase the vehicle speed. The range for speed calibration is 0 to 30. Each time the number is increased, the top speed will be decreased by approximately 0.1 mph (0.2 km/h). The top vehicle speed will be determined by the *M1/M2 speed* menu item and the speed calibration setting. For example, if the speed setting is set for a value of 3 (15.0 mph (24.1 km/h)), and the speed calibration is set for 5, the total top speed of the vehicle should be approximately 14.5 mph (23.3 km/h). See the table below for a list of possible approximate speed calibrations.

M1/M2 Speed Cal	Speed Setting			
	1	2	3	4
0	8.0 mph (12.9 km/h)	12.0 mph (19.3 km/h)	15.0 mph (24.1 km/h)	17.0 mph (27.4 km/h)
1	7.9 mph (12.7 km/h)	11.9 mph (19.2 km/h)	14.9 mph (24.0 km/h)	16.9 mph (27.2 km/h)
2	7.8 mph (12.6 km/h)	11.8 mph (19.0 km/h)	14.8 mph (23.8 km/h)	16.8 mph (27.0 km/h)
3	7.7 mph (12.4 km/h)	11.7 mph (18.8 km/h)	14.7 mph (23.7 km/h)	16.7 mph (26.9 km/h)
4	7.6 mph (12.2 km/h)	11.6 mph (18.7 km/h)	14.6 mph (23.5 km/h)	16.6 mph (26.7 km/h)
5	7.5 mph (12.1 km/h)	11.5 mph (18.5 km/h)	14.5 mph (23.3 km/h)	16.5 mph (26.6 km/h)
6	7.4 mph (11.9 km/h)	11.4 mph (18.3 km/h)	14.4 mph (23.2 km/h)	16.4 mph (26.4 km/h)
7	7.3 mph (11.7 km/h)	11.3 mph (18.2 km/h)	14.3 mph (23.0 km/h)	16.3 mph (26.2 km/h)
8	7.2 mph (11.6 km/h)	11.2 mph (18.0 km/h)	14.2 mph (22.9 km/h)	16.2 mph (26.1 km/h)
9	7.1 mph (11.4 km/h)	11.1 mph (17.9 km/h)	14.1 mph (22.7 km/h)	16.1 mph (26.0 km/h)
10	7.0 mph (11.3 km/h)	11.0 mph (17.7 km/h)	14.0 mph (22.5 km/h)	16.0 mph (25.7 km/h)
11	6.9 mph (11.1 km/h)	10.9 mph (17.5 km/h)	13.9 mph (22.4 km/h)	15.9 mph (25.6 km/h)
12	6.8 mph (10.9 km/h)	10.8 mph (17.4 km/h)	13.8 mph (22.2 km/h)	15.8 mph (25.4 km/h)
13	6.7 mph (10.8 km/h)	10.7 mph (17.2 km/h)	13.7 mph (22.0 km/h)	15.7 mph (25.3 km/h)
14	6.6 mph (10.6 km/h)	10.6 mph (17.1 km/h)	13.6 mph (21.9 km/h)	15.6 mph (25.1 km/h)
15	6.5 mph (10.5 km/h)	10.5 mph (16.9 km/h)	13.5 mph (21.7 km/h)	15.5 mph (25.0 km/h)
16	6.4 mph (10.3 km/h)	10.4 mph (16.7 km/h)	13.4 mph (21.6 km/h)	15.4 mph (24.8 km/h)
17	6.3 mph (10.1 km/h)	10.3 mph (16.6 km/h)	13.3 mph (21.4 km/h)	15.3 mph (24.6 km/h)
18	6.2 mph (10.0 km/h)	10.2 mph (16.4 km/h)	13.2 mph (21.2 km/h)	15.2 mph (24.5 km/h)
19	6.1 mph (9.8 km/h)	10.1 mph (16.3 km/h)	13.1 mph (21.0 km/h)	15.1 mph (24.3 km/h)
20	6.0 mph (9.7 km/h)	10.0 mph (16.1 km/h)	13.0 mph (20.9 km/h)	15.0 mph (24.1 km/h)
21	5.9 mph (9.5 km/h)	9.9 mph (15.9 km/h)	12.9 mph (20.8 km/h)	14.9 mph (24.0 km/h)
22	5.8 mph (9.3 km/h)	9.8 mph (15.8 km/h)	12.8 mph (20.6 km/h)	14.8 mph (23.8 km/h)

TABLE CONTINUED ON NEXT PAGE

23	5.7 mph (9.2 km/h)	9.7 mph (15.6 km/h)	12.7 mph (20.4 km/h)	14.7 mph (23.7 km/h)
24	5.6 mph (9.0 km/h)	9.6 mph (15.4 km/h)	12.6 mph (20.3 km/h)	14.6 mph (23.5 km/h)
25	5.5 mph (8.9 km/h)	9.5 mph (15.3 km/h)	12.5 mph (20.1 km/h)	14.5 mph (23.3 km/h)
26	5.4 mph (8.7 km/h)	9.4 mph (15.1 km/h)	12.4 mph (20.0 km/h)	14.4 mph (23.2 km/h)
27	5.3 mph (8.5 km/h)	9.3 mph (15.0 km/h)	12.3 mph (19.8 km/h)	14.3 mph (23.0 km/h)
28	5.2 mph (8.4 km/h)	9.2 mph (14.8 km/h)	12.2 mph (19.6 km/h)	14.2 mph (22.9 km/h)
29	5.1 mph (8.2 km/h)	9.1 mph (14.6 km/h)	12.1 mph (19.5 km/h)	14.1 mph (22.7 km/h)
30	5.0 mph (8.0 km/h)	9.0 mph (14.5 km/h)	12.0 mph (19.3 km/h)	14.0 mph (22.5 km/h)

Control Mode

The *control mode* option is used to configure the controller for different modes of speed control operation. Four modes are available:

- 0 = Standard: Uses maximum speeds defined in the parameters.
- 1 = LIN (Local Interconnect bus) (i.e. Guardian or Visage): Uses maximum speeds assigned to a particular location or area as defined by the fleet operator; however, these defined speeds can not override maximums set in the parameters.
- 2 = ES-Protocol (UpLink): Uses maximum speeds assigned to a particular location or area as defined by the fleet operator; however, these defined speeds can not override previously set values from other *control mode* options. To avoid this, after changing the *control mode* to 2, cycle power to the controller by placing the Run/Tow Switch in the TOW position for 30 seconds. Then return it to RUN.
- 3 = Deterrent Demo Mode: Uses maximum speeds defined by the *deterrent demo* setting to demonstrate the automatic speed control features of Guardian and UpLink. **See Deterrent Demo on page 11-8.**

Anti-Tamper

The *anti-tamper* setting defines maximum speed if the Anti-Tamper fault is triggered (e.g. controller is disconnected from the Guardian or Visage system). These speeds can only be activated if the Control Mode option is set to 1 (Guardian/Visage) and are intended to be a deterrent. Factory default setting is 1.

- 0 = OFF; uses controller configured speed even if the Anti-Tamper fault is triggered
- 1 = 2 mph
- 2 = 0 mph
- 3 = 7 mph

Deterrent Demo

The *deterrent demo* setting defines maximum speed of Control Mode 3.

- 0 = Controller configured speed
- 1 = 10 mph
- 2 = 7 mph
- 3 = 2 mph

WalkAway Deterrent

The *walkaway deterrent* menu item allows the user to turn this function ON or OFF. *Walkaway deterrent* is triggered by the High Speed WalkAway fault. With it ON, the reverse buzzer will sound immediately upon the key switch being turned OFF at speeds above 2 mph. With it OFF, the buzzer will cycle on and off at a higher frequency (7.5 Hz vs. 2.5 Hz).

Battery Type

The *battery type* menu item is intended to be used with Guardian/Visage so that the type of battery could be determined and displayed when remotely monitoring vehicles.

Charger Control

Beep Option

The *Beep Option* controls use of the reverse buzzer to sound a confirmation that charging has started: 0 = OFF, 1 = 1 beep, 2 = 3 beeps. From the factory, the *Beep Option* will be set to 2.

AMP HOURS**Reset Trip Amp Hours**

The *reset trip amp hours* menu item allows the user to reset counter to zero (0). To reset, set to ON and then immediately back to OFF. To review or validate, proceed to Amp Hours Display on page 11-15 under the Monitor Menu.

ACCESS CODES**Code A, Code B, and Code C**

NOTE: *Smartkey: Mode 2 and Code A, Code B, and Code C are available as part of the Smartkey option. The Smartkey feature is available as a factory option, or as a field kit (102962602 Kit, Field, Smartkey) and can be ordered from Service Parts.*

The code entries are used to activate Mode 2 (M2) functions in the Parameters Menu. Each vehicle has a unique code for placing the vehicle in this mode.

Once activated, Mode 2 settings can be programmed using the same procedures as Mode 1 settings. This allows the vehicle to be customized to perform according to which mode it is operated in. For more information on this feature, contact your local Club Car distributor or dealer.

To activate Mode 2:

1. Enter Code A, Code B, and Code C.
2. Turn the Run/Tow switch to Tow.
3. Wait 30 seconds.
4. Turn the Run/Tow switch to Run.
5. M2 options will now appear in the Parameters Menu.

VEHICLE ID**S/N ASCII Letter 1****S/N ASCII Letter 2**

The two-letter serial number prefix is coded as two separate ASCII characters per the following table. For example, serial number JE1401-000001 would have 74 for *S/N ASCII Letter 1* and 69 for *S/N ASCII Letter 2*.

ASCII NUMBER	ASCII CHARACTER	ASCII NUMBER	ASCII CHARACTER
65	A	78	N
66	B	79	O
67	C	80	P
68	D	81	Q

TABLE CONTINUED ON NEXT PAGE

ASCII NUMBER	ASCII CHARACTER	ASCII NUMBER	ASCII CHARACTER
69	E	82	R
70	F	83	S
71	G	84	T
72	H	85	U
73	I	86	V
74	J	87	W
75	K	88	X
76	L	89	Y
77	M	90	Z

Vehicle Date of Manufacture

Four digit number programmed by vehicle manufacturer. **Example:** 1401 represents Model Year 2014, week 1.

Vehicle S/N

Six digit number programmed by vehicle manufacturer.

Vehicle Decal

Decal number ranging from 0 to 999 and programmed by vehicle manufacturer.

MONITOR MENU

The *Monitor* menu is accessed by using the arrow keys to highlight *Monitor* and pressing the *Select* softkey to activate the menu.

All information in the *Monitor* menu is updated in real time, allowing the trained technician to troubleshoot the vehicle by monitoring the handset as the key switch is cycled, Forward/Reverse switch is activated, etc. **See following NOTE.**

NOTE: Values appearing in these menus represent approximate measurements made by the controller and may differ from measurements made by external instruments.

Since the *Monitor* menu is updated while the vehicle is in operation, the trained technician has the ability to monitor the status of several components in conditions or locations where a problem with vehicle performance has been reported. **See following WARNING.**

WARNING

- The vehicle operator should not monitor the handset while the vehicle is in motion. A technician can monitor the handset while traveling as a passenger in the vehicle. Failure to heed this warning could result in severe personal injury or death.

The following parameters can be monitored in real time with the handset from the *Monitor* menu:

SPEED IN

Indicates the approximate ground speed of the vehicle in miles per hour (MPH).

THROTTLE %

Indicates the position of the accelerator pedal from 0% (pedal not pressed) to 95% and 100% (pedal fully pressed). This item can be monitored when the key switch is in the ON or OFF position.

BATT VOLTAGE

Displays the current battery voltage at the speed controller.

HEATSINK TEMP

Displays the temperature (in degrees Celsius) of the speed controller heatsink. During normal operating conditions, the heatsink temperature should be below 85 °C (±5) (185 °F (±9)). **See following NOTE.**

NOTE: *Improper brake adjustment can sometimes cause the operating current to be higher than normal. This higher current increases the temperature of the speed controller heatsink.*

MODE

Indicates what mode the vehicle is being operated in (Mode 1 or Mode 2).

ARM CURRENT

Displays the motor armature current (in amperes).

FIELD CURRENT

Displays the motor field current (in amperes).

ARM PWM

Displays motor armature PWM (pulse width modulation). The range of pulse width modulation is 0% to 100%. When the vehicle is operating at full speed, the pulse width modulation should be at 100%.

FIELD PWM

Displays motor field PWM (pulse width modulation). The range of pulse width modulation is 0% to 100%. When the vehicle is in operation, the pulse width modulation will fluctuate in response to the terrain and throttle input.

FOOT INPUT

Indicates the status of the MCOR (motor controller output regulator) internal limit switch: on or off. When the accelerator pedal is unpressed, the handset should indicate that the limit switch is off. When the accelerator pedal is pressed and the key switch is in the ON position, the display should indicate that the limit switch is on.

KEY INPUT

Displays the position of the key switch: OFF or ON.

FORWARD INPUT

With the Forward/Reverse switch in the NEUTRAL or REVERSE position, the handset should indicate that the forward input is off. When the Forward/Reverse switch is placed in the FORWARD position, the handset should indicate that the forward input is on.

REVERSE INPUT

With the Forward/Reverse switch in the NEUTRAL or FORWARD position, the handset should indicate that the reverse input is off. When the Forward/Reverse switch is placed in the REVERSE position, the handset should indicate that the reverse input is on.

MODE SWITCH

Indicates what position the Mode Switch is in (On or Off).

WK AWAY RELAY

Displays the state of the Walk Away Relay (On or Off). If the speed controller detects that the throttle is at 0% and the vehicle is moving, the relay will activate, reversing the direction of the field current until no motion of the vehicle is detected.

MAIN CONT

Displays the state of the solenoid (main contactor). When the contactor is activated, the handset indicates that the solenoid is on. When the contactor is not activated, the handset indicates that the solenoid is off.

PASSWORD TRIES (OEM ACCESS LEVEL ONLY)

A password is required to activate Mode 2. The speed controller will log unsuccessful and unauthorized attempts to activate Mode 2. If repeated attempts are unsuccessful, the speed controller will permanently lock out access to Mode 2. In the event that Mode 2 is locked out, the controller must be removed and shipped to Club Car before Mode 2 can be activated.

***NOTE:** The lower portion of the monitor menu contains the fault counter information. Each fault is listed in the left hand column and the number of occurrences will be listed in the right hand column.*

CIR BRKR OPEN

Displays the number of times the CIR BRKR OPEN fault has been detected. **See Fault Descriptions on page 11-20.**

THRTL FAULT

Displays the number of times the THRTL fault has been detected. **See Fault Descriptions on page 11-20.**

UNDERVOLTAGE

Displays the number of times the UNDERVOLTAGE fault has been detected. **See Fault Descriptions on page 11-20.**

OVERVOLTAGE

Displays the number of times the OVERVOLTAGE fault has been detected. **See Fault Descriptions on page 11-20.**

TEMP CUTBACK

Displays the number of times the TEMP CUTBACK fault has been detected. **See Fault Descriptions on page 11-20.**

HPD

Displays the number of times the HPD fault has been detected. **See Fault Descriptions on page 11-20.**

MAIN WELDED

Displays the number of times the MAIN WELDED fault has been detected. **See Fault Descriptions on page 11-20.**

RELAY WELDED #

Displays the number of times the RELAY WELDED fault has been detected. **See Fault Descriptions on page 11-20.**

SPD SENSOR #

Displays the number of times the SPD SENSOR fault has been detected. **See Fault Descriptions on page 11-20.**

MAIN DRV ON #

Displays the number of times the MAIN DRV ON fault has been detected. **See Fault Descriptions on page 11-20.**

MAIN COIL OPN #

Displays the number of times the MAIN COIL OPN fault has been detected. **See Fault Descriptions on page 11-20.**

MAIN DROPOUT #

Displays the number of times the MAIN DROPOUT fault has been detected. **See Fault Descriptions on page 11-20.**

MOTOR STALL #

Displays the number of times the MOTOR STALL fault has been detected. **See Fault Descriptions on page 11-20.**

MAIN DRVR OFF#

Displays the number of times the MAIN DRVR OFF fault has been detected. **See Fault Descriptions on page 11-20.**

RELAY DNC #

Displays the number of times the RELAY DNC fault has been detected (Did not close). **See Fault Descriptions on page 11-20.**

CURRENT SENSE #

Displays the number of times the CURRENT SENSE fault has been detected. **See Fault Descriptions on page 11-20.**

M-SHORTED #

Displays the number of times the M-SHORTED fault has been detected. **See Fault Descriptions on page 11-20.**

RELAY COIL #

Displays the number of times the RELAY COIL fault has been detected. **See Fault Descriptions on page 11-20.**

PRECHARGE #

Displays the number of times the PRECHARGE fault has been detected. **See Fault Descriptions on page 11-20.**

FLD MISSING #

Displays the number of times the FLD MISSING fault has been detected. **See Fault Descriptions on page 11-20.**

HW FAILSAFE #

Displays the number of times the HW FAILSAFE fault has been detected. **See Fault Descriptions on page 11-20.**

DRVR OVERCUR #

Displays the number of times the DRVR OVERCUR fault has been detected. **See Fault Descriptions on page 11-20.**

RLY DRVR ON #

Displays the number of times the RLY DRVR ON fault has been detected. **See Fault Descriptions on page 11-20.**

RLY DRVR OFF #

Displays the number of times the RLY DRVR OFF fault has been detected. **See Fault Descriptions on page 11-20.**

V_{MIN} I

Displays volts (minimum) at a certain amperage. This is a setting parameter used with the Low SOC (State of Charge) detection fault.

SIGNED BATTERY CURRENT

While driving the vehicle, this displays either the current being pulled out of the batteries or the current being returned to the batteries during regenerative motor braking. It has a range from negative (-) 300 amps to positive (+) 300 amps.

BDI PERCENT

Battery Discharge Indicator (BDI) Percent displays the current battery state of charge as a percent. It is based on several parameters monitored by the controller.

CHARGER INHIBIT

Displays charger connection. When the charger is connected and the controller does not drive (inhibited), the handset indicates ON. When the charger is not connected and the controller is allowed to drive, the handset indicates OFF.

LED DRIVER

Displays the present state of pin 11 in the controller 16-pin connector that operates the charge indicator light on the dash. When pin 11 is activated, power is provided to the light and the handset indicates that the LED Driver is ON. When pin 11 is not activated, the handset indicates that the LED Driver is OFF.

ODOMETER

Displays approximate distance travelled in miles.

BDI INFO**Load Line SOC**

Load Line SOC is the state of charge estimation based upon battery voltage during a defined discharge current (between 50 and 60 amps).

Load Line Valid

Load Line Valid is an indication (Load Line Valid = 1) that the discharge current is between 50 and 60 amps.

BDI Int Factor

BDI Int Factor is an auto-adjusting correction factor for estimating state of charge based upon the difference between the currently estimated state of charge and the Load Line SOC.

Open Circuit Voltage Start

Open Circuit Voltage Start is the voltage, as determined by the controller, following a cycle of the Run/Tow switch or coming out of sleep mode.

Open Circuit SOC Start

Open Circuit SOC Start is the estimated state of charge following a cycle of the Run/Tow switch or coming out of sleep mode.

BATTERY MONITOR

These menu items reset every time the vehicle is charged.

Lowest Battery Voltage

Displays the lowest battery pack voltage reached since the last charge.

I Batt at Lowest Volts

Displays the current through the controller at the lowest battery pack voltage.

Highest Battery Voltage

Displays the highest battery pack voltage after being charged.

CHARGING TOTALS

These menu items accumulate totals for the life of the vehicle.

Completed Charges

Displays the number of completed charge cycles.

Interrupted Charges

Displays the number of interrupted charge cycles.

Storage Charges

Displays the number of storage charge cycles.

AMP HOURS DISPLAY**Signed Battery Current**

While driving the vehicle, this displays either the current being pulled out of the batteries or the current being returned to the batteries during regenerative motor braking. It has a range from negative (-) 300 amps to positive (+) 300 amps.

Amp Hours

Displays total accumulated amp hours removed from batteries since initial vehicle start-up.

Regen Amp Hours

Displays total accumulated amp hours returned to the batteries from regenerative braking since initial vehicle start-up.

Charge Amp Hours

Displays amp hours removed from batteries since the last charge.

Charge Regen Amp Hours

Displays amp hours returned to the batteries from regenerative braking since the last charge.

Trip Amp Hours

Displays amp hours removed from batteries since *trip amp hours* was reset. **See Reset Trip Amp Hours on page 11-9.**

Trip Regen Amp Hours

Displays amp hours returned to the batteries from regenerative braking since *trip amp hours* was reset.

LIN

Relates to communication between the controller and the Guardian/Visage device (if equipped).

Charger

Additional

DIAGNOSTICS MENU

CAUTION

- **A failed motor will damage the controller. Always inspect the motor before replacing the controller. See External Motor Testing, Section 16, Page 16-1.**

NOTE: *The software is subject to frequent updates, and this manual may span many versions. Be aware that some faults listed in this manual may not display in the CDT, indicating older software.*

Sometimes the fault circuits catch a temporary event that is not a true fault in the system. It is good practice to turn the control system OFF and back ON again to see if the fault clears by itself.

The *Diagnostics* menu is accessed by using the arrow keys to highlight *Diagnostics* and pressing the *Select* softkey to activate the menu. Under the *Diagnostics* menu are two folders: *Present Errors* and *Fault History*.

Faults displayed in the *Diagnostics* menu will aid the trained technician in troubleshooting the vehicle. Faults displayed often indicate which components in the electrical system need to be tested.

Since the *Diagnostics* menu is updated while the vehicle is in operation, the trained technician has the ability to monitor the occurrence of faults in conditions or locations where a problem with vehicle performance has been reported. **See following WARNING.**

▲ WARNING

- **The vehicle operator should not monitor the handset while the vehicle is in motion. A technician can monitor the handset while traveling as a passenger in the vehicle. Failure to heed this warning could result in severe personal injury or death.**

PRESENT ERRORS FOLDER

The *Fault History* folder displays all existing faults in chronological order. An item in this folder can only be removed by remedying the fault. As long as the fault exists, it will be included in the *Present Errors* folder. The “number / number” in the upper right corner of the screen indicates the number of present faults and which fault is highlighted. *Example:* “1/3” means the first of three total faults is highlighted.

FAULT HISTORY FOLDER

The *Fault History* folder displays all of the faults detected by the controller since the last time the fault history has been cleared. The faults displayed in this folder may or may not be currently active. Once a fault has been detected, it is stored in the memory of the controller for display on the *Fault History* folder. Each detected fault is listed only once, even if the fault has occurred multiple times. You can clear the entire contents of this folder to allow a fresh *Fault History* to be started.

SYSTEM FAULTS

NOTE: *The system faults menu displays all of the present faults detected by the speed controller. The faults displayed in this menu are currently active. Once a fault has been detected, it is stored in the memory of the speed controller for display on the fault history menu. Each detected fault is listed only once in the fault history menu, the number of fault occurrences are located in the fault counter section of the monitor menu, even if the fault has occurred multiple times.*

Causes of Faults

Some common causes of faults are

- Loose, broken, or disconnected wires or connectors
- Failed components
- Improper adjustment or installation of electrical or mechanical components (examples: brake adjustment, improper MCOR installation)
- Improper wiring of electrical components

As shown above, there are many possible causes for faults to occur, and the speed controller has a programmed reaction to each fault that is based on the fault currently detected. The technician should be familiar with the detected faults and the controller's reactions to faults to ensure a proper diagnosis.

An example of a possible mis-diagnosis of a vehicle due to a fault: If the three-pin speed sensor wire has been disconnected, the speed controller will detect a *speed sensor* fault. When a *speed sensor* fault is detected, the controller responds to the fault by limiting the vehicle speed to 1/2 of its normal top speed. If the technician reaches the conclusion that the vehicle is running slowly because batteries are heavily discharged, he has made an improper diagnosis of the problem.

The vehicle speed controller should be checked for fault codes before any service is performed.

The speed controller, after detecting a fault, will respond in one or more of the following ways:

1. Reduce vehicle speed to zero by reducing armature current to zero
2. Reduce vehicle speed to zero by reducing field current to zero
3. Turn off Main Contactor
4. "Limp-Home:" Cause the vehicle to run at half speed
5. Gradually reduce the armature current limit
6. Quickly reduce the armature current until speed sensor pulses occur
7. Gradually reduce Regen Current Limit
8. SmartKey functions NOT enabled
9. PASSWORD TRIES count incremented
10. Set Internal Scaled Throttle Signal to Zero
11. Turn off Walk Away Relay
12. Activate Walk Away function
13. Activate Walk Away beeping immediately

FAULT RECOVERY

When a fault is detected by the speed controller, the speed controller will attempt to recover from the fault and resume normal operation. In the case of an intermittent problem such as a loose wiring connection, the controller **may** be able to recover and operate normally for a while, but the problem should be repaired before placing the vehicle in service.

Depending on the type of fault, the controller will attempt to recover immediately after the condition clears or after the accelerator pedal has been cycled (released and pressed again).

CONTROLLER FAULT	TEST WHEN	CONTROLLER RESPONSE	RECOVER WHEN
01 THROTTLE FAULT 1	Continuous	10	Condition clears
02 UNDER VOLTAGE	Continuous	5	Condition clears
03 OVERVOLTAGE	Continuous	7	Condition clears
04 THERMAL CUTBACK	Continuous	5	Condition clears
06 HPD	KSI Off/On, F or R on	10	Throttle < 25%
07 MAIN WELDED	Contactors commanded open	4	Main or relay successfully opened
08 RELAY WELDED	After Walk Away sequenced	4	Main or relay successfully opened
09 SPEED SENSOR FAULT	Throttle Applied, Arm PWM > 50%	4	Speed pulses appear
10 MAIN DRIVER ON	Continuous while KSI is ON	4	Condition clears
11 MAIN COIL OPEN	Continuous while KSI is ON	3	Condition clears
12 MAIN DROPOUT	Throttle applied	3,12	Throttle applied
13 MOTOR STALL	Throttle applied	6	Speed pulses appear
14 MAIN DRIVER OFF	Throttle applied	3,10	Condition clears
15 RELAY DNC	WalkAway	2,13	Throttle applied
16 KEY SWITCH SRO	At controller power up	3	Cycle KSI
17 CURRENT SENSE FAULT	KSI Off/On, Continuous	1,2,3	KSI Off/On when condition cleared
18 M-SHORTED	Throttle Applied	1,2	Throttle Cycled
20 DRIVER OVERCURRENT	Continuous	1,2,3,11	Throttle Reapplied
21 PRECHARGE FAULT	Throttle Applied	1,2,3,11	Cycle KSI or Throttle reapplied
22 FIELD MISSING	Throttle Applied	2,10,11	Cycle KSI
23 RELAY DRIVER ON	Continuous	4	Condition clears
24 HW FAILSAFE	Throttle Applied	1,2,3,11	Cycle KSI
25 INCORRECT PASSWORD	At power up, after SmartKey codes entered	8,9	Cycle Run/Tow
26 CIRCUIT BRKR OPEN	Continuous	4	Condition Clears
27 MAX PASSWORD TRIES	At power up, after SmartKey codes entered	8	Not Field Repairable
29 RELAY DRVR OFF	WalkAway	2,13	Condition clears in WalkAway
30 RELAY COIL FAULT	Continuous	4	Condition clears

FAULT DESCRIPTIONS

The following faults can be detected by the IQ Plus controller and seen under both the *Monitor Menu* and *Diagnostics Menu*:

01 THROTTLE FAULT 1

If the MCOR (Motor Controller Output Regulator) voltage is less than 0.20 volts or greater than 4.80 volts, the controller detects a *throttle fault*.

02 LOW BATTERY VOLTAGE

If the battery voltage falls below 34 volts ($\pm 5\%$), the *low battery voltage* fault is detected by the speed controller.

03 OVERVOLTAGE

If the speed controller detects that the battery voltage is too high (72 volts ($\pm 5\%$)), the *overvoltage* fault is detected.

04 THERMAL CUTBACK

If the controller heatsink temperature is found to be in excess of 85 °C (± 5) (185 °F (± 9)) or below -25 °C (± 5) (-13 °F (± 9)), the *thermal cutback* fault is detected.

06 HPD

The *HPD* (High Pedal Detect) fault is detected if the accelerator pedal is already depressed when the key switch is turned to the ON position. This fault, when not caused by the operator, can indicate that the pedal limit switch has failed closed.

07 MAIN WELDED

If the speed controller detects that the solenoid contacts are welded closed, a *main welded* fault is detected.

08 RELAY WELDED

If the speed controller detects that the external Walk Away relay contacts are welded closed, a *relay welded* fault is detected.

09 SPEED SENSOR

If the speed controller does not detect pulses from the speed sensor while the controller outputs power (greater than 75% armature PWM) to the motor, a *speed sensor* fault is detected.

10 MAIN DRIVER ON

If the FET that controls the activation of the solenoid coil is found to be energized when it should not be, a *main driver on* fault is detected by the speed controller.

11 MAIN COIL OPEN

If the Main Contactor Coil develops an open circuit or is disconnected from the controller, a *main coil open* fault is detected. Walk Away is not affected by this fault.

12 MAIN DROPOUT

If the controller detects that the solenoid contacts have opened while the vehicle is in operation, a *main dropout* fault is detected.

13 MOTOR STALL

If the motor current is high and there is no movement of the vehicle wheels for a short period of time, a *motor stall* is detected by the speed controller. This fault can be caused by an operator holding the vehicle on a hill by depressing the accelerator pedal instead of the brake pedal.

14 MAIN DRIVER OFF

If the FET that controls the activation of the solenoid coil is **not** energized when it should be, a *main driver off* fault is detected by the speed controller.

15 RELAY DNC

If the external Walk Away Relay contacts do not close, a *relay dnc* is detected.

16 KEYSWITCH SRO

If the key switch is in the ON position when the controller is powered up, a *key switch sro* fault is detected. This fault detection feature may be turned on or off with an CDT. Factory default setting is off.

17 CURRENT SENSE

If there are problems with the armature current sensor circuitry, a *current sense* fault is detected.

18 M- SHORTED

If an uncontrolled current path is detected from the motor to B- (bypassing the MOSFETs), an *M- shorted* fault is detected.

20 DRIVER OVERCURRENT

If the current on the relay driver exceeds 120 mA, or the current on the solenoid driver exceeds 6 A, a *driver overcurrent* fault is detected.

21 PRECHARGE FAULT

If the internal precharge circuit fails, or there is a short between the B+ and B- controller terminals, a *precharge* fault is detected.

22 FIELD MISSING

If the speed controller is operating at a duty cycle of greater than 90% (almost full speed) and the field current is less than 3 amps, a *field missing* fault is detected by the speed controller.

23 RELAY DRIVER ON

If the relay driver has been commanded to turn OFF, but remains on, a *relay driver on* fault is detected.

24 HW FAILSAFE

If the speed controller detects a failure of the armature drive FETs or circuitry, an *hw failsafe* fault is detected.

25 INCORRECT PASSWORD

If an incorrect attempt is made to activate Mode 2 by entering Code A, Code B, or Code C, an *incorrect password* fault is detected.

26 CIRCUIT BRKR OPEN

If the circuit breaker element in the Walk Away circuit is blown, or not wired to the controller, a *circuit brkr open* fault is detected.

27 MAX PASSWORD TRIES

The *max password tries* fault is declared when the incorrect password fault has been declared several times. In the event that the *max password tries* fault is indicated, the speed controller must be removed and shipped to Club Car before it can ever be placed in Mode 2. **See also** Password Tries (OEM Access Level Only) on page 11-12.

29 RELAY DRVR OFF

If the Walk Away relay driver FET remains in the OFF state when commanded to switch on, a *relay drvr off* fault is detected.

30 RELAY COIL FAULT

If the Walk Away relay develops an open circuit or is disconnected from the controller, a *relay coil fault* is detected.

ANTI-TAMPER FAULT

If communication with the Visage or Guardian unit is interrupted, the controller registers an *anti-tamper fault*.

What it means: This is a symptom, not a cause. The controller is set to communicate with a Visage or Guardian unit and it is unable to.

What to do: Clear the Fault History in the CDT. Ensure wiring is connected and inspect for damaged wires. If the vehicle is not or no longer going to be equipped with these services, change Control Mode setting to zero (0).

LOCKOUT FAULT

If the controller receives a signal that the charger interlock is activated while the vehicle is being driven, the controller registers a *lockout fault* and may prevent the vehicle from operating.

What it means: This is a symptom, not a cause. The controller should only see charger interlock activated when the charger's DC cord (external charger) is connected to the vehicle or AC cord (onboard charger) is connected to an AC outlet. One possible cause is failure of the 10k ohm resistor in the charger interlock circuit.

What to do: Clear the Fault History in the CDT. If the fault does not return and the car operates normally, do not replace the controller. If the fault continues to occur, inspect and test the charger interlock circuit. **See Test Procedure 11 – Charger Interlock on page 12-26.** If the 10k ohm resistor has failed, replace resistor. If no problems are found in the charger interlock circuit, replace the controller.

LOW SOC

If the controller sees that the battery pack has reached a low state of charge (SOC), the controller registers a *low SOC fault*.

What it means: This is a symptom, not a cause. The controller records the number of times this occurs.

What to do: Charge batteries. If fault occurs more frequently than normal, test battery pack. Section 14 — Batteries: IQ Plus Electric Vehicles

MAIN CONT DNC

The *main cont dnc* (main contactor (solenoid) did not close) fault is detected when the speed controller has sent voltage to the solenoid activating coil but the solenoid contacts are not closed.

MAIN COIL FAULT

If the speed controller determines that the solenoid is not closing as a result of a solenoid coil failure, a *main coil fault* is detected.

PROC/WIRING

This fault is detected if the Forward/Reverse switch is giving a signal to place the controller in forward and reverse at the same time. This rare fault can be caused by a failed Forward/Reverse switch or improper vehicle wiring.

OPEN ARMATURE

If the accelerator pedal is pressed 2/3 to the floor, the armature current is less than 20 amps, and there are no speed sensor pulses, an *open armature* fault is detected.

INCORRECT PASSWORD (OEM ACCESS LEVEL ONLY)

Each vehicle has a password in the form of a unique set of codes used to activate Mode 2. If a set of codes has been entered incorrectly, the *incorrect password* fault is declared. **See also** Password Tries (OEM Access Level Only) on page 11-12.

FAULT HISTORY

The *fault history* menu can be useful in determining the cause of a vehicle problem; however, the fault history alone should not be the factor that determines when a component is replaced. Some faults detected by the speed controller are not the result of a failed component, and are instead the result of vehicle operator error. If a fault appears in the *fault history* menu, the trained technician should attempt to determine when and where the fault has occurred. For example, if the *motor stall* fault is present in the fault history, the trained technician may be able to determine the location on the course where an operator has held the vehicle on a hill by using the accelerator pedal.

CLEARING FAULT HISTORY

After a repair has been made, the fault history should be cleared. This will enable the trained technician to properly troubleshoot the vehicle in the future, in the event that another problem occurs. If the fault history is not cleared after a repair, a technician may mistakenly replace a new component due to an old fault code. For example, if the MCOR device was disconnected and the speed controller detected a fault code associated with the throttle, the fault history should be cleared so that any future problem is not diagnosed incorrectly as a throttle problem. **See Fault History Folder on page 11-17.**

PROGRAMMING

The *Programming* menu is accessed by using the arrow keys to highlight *Programming* and pressing the *Select* softkey to activate the menu.

The *Programming* menu selection allows the user to save and restore parameter settings files (.cpf files). These files contain controller information and are saved to the internal memory or SD card. Once saved, they can be used for future reference or emailed when the CDT or SD card is connected to a PC. For information on how to save and restore these files, refer to the manual supplied with the CDT.

CLONING

Use the “Restore .cpf File” function to clone a controller with a saved .cpf file stored in the CDT.

If using an OEM-level CDT, after you highlight a stored .cpf file and choose “Restore,” a pop-up window will ask whether you want to enable Advanced Cloning (“Yes”/“No”) using the softkeys. This choice is not offered in the User-level CDT. Without Advanced Cloning (if you select “No”), an OEM-level CDT will restore only those parameters up to and including OEM level. Advanced Cloning (“Yes”) restores all parameters, including those at a higher level. This makes a true clone by copying parameters that cannot be seen at the OEM level. It is recommended to enable Advanced Cloning.

FAVORITES

The *Favorites* menu is accessed by pressing the Favorites key (9) (**Figure 11-1, Page 11-1**). This menu can also be accessed by using the arrow keys to highlight *Favorites* and pressing the *Select* softkey to activate the menu. Return to the Main Menu at any time by pressing the Main Menu key (6).

The *Favorites* menu selection consists of the custom set of items you have created. Typically, you will want to include the parameters you most frequently adjust, along with the monitor items you most frequently check. This way you can go directly to these items more easily than by navigating through the entire Parameters and Monitor menus.

Any item or folder in the Parameters or Monitor menu can be added to Favorites. Once added, it can be renamed if desired. When you add a ready-made folder from the Parameters or Monitor menu, the folder icon will appear in the Favorites menu with a star on it. Although you can rename a ready-made folder, you are not allowed to rename any of the items within that folder. You can also create folders of your own to hold specific sets of items; these folders will be indicated with the usual folder icon. You may want to create a folder for each type of vehicle or application, or for each customer.

HHP SETTINGS

The *HHP Settings* menu is accessed by using the arrow keys to highlight *HHP Settings* and pressing the *Select* softkey to activate the menu.

The *HHP Settings* menu selection allows the user to adjust the appearance of the screen displays, adjust several aspects of the handheld programmer's functionality, and displays information pertaining to the handset.

MENU ITEM	DESCRIPTIONS
Access Level	The Access Level of the programmer can be set to its own level or to any lower level: OEM, Dealer, Service, User. Setting the Access Level to a lower level allows you to see what a person with that level programmer would see. For example, a dealer could set the Access Level to User, to see what a person with a User-level programmer would see.
Language	You can select English, Deutsch, Français, Italiano, or Español for the screen text.
Left Handed Soft Keys	Selecting "Yes" for Left Handed Soft Keys reverses the position of items in the softkey text line, to make the keys more convenient for left-handed people.
Backlight	Here you can set the brightness of the programmer's LCD display—from 100% to 20%, in 5% increments.
Keytone	You can choose between several tones to sound each time you press a key, or you can turn the keytone Off for silent programmer operation.
Auto Poweroff (battery)	You can set the idle time before the programmer will automatically power off when it is powered by its own batteries (i.e., when the control system is not running, or when the programmer is not connected to the control system).
Auto Poweroff (ext)	You can set the idle time before the programmer will automatically power off when it is being powered by the controller.
Exit menus with left arrow	The left-arrow key () is used to navigate backwards within menus. When set to Yes, you can use the left-arrow key to leave the presently displayed screen and return to the next higher (i.e., previous) screen; using the left-arrow key will eventually return you to the Main Menu. When set to No, you must use the appropriate softkeys (Exit, Cancel) and the Main Menu key () to leave the present screen and reach the Main Menu. You may find this setting preferable if you use the table screens frequently, as it eliminates any possible confusion caused by the left-arrow key having two functions: moving one cell to the left, and exiting the table altogether.
Enable Screenshot	The Yes/No setting of this item determines whether the programmer will allow screenshots to be taken; see Section 14 for a description of this function. When set to "No," if you attempt to take a screenshot—by pressing the Power key () followed by the Favorites key ()—the power command is ignored and the screen jumps to the Favorites menu in response to the Favorites key command.
Show only empty battery	A battery icon showing the state-of-charge of the programmer's battery can be displayed in the upper right corner of the screen. If you do not want the icon to be displayed except as a warning when the battery is empty, set this to "Yes."
Text for save as	When you create a new .cpf file, the field at the top of the keyboard screen is either blank ("No text") or is automatically filled with the date and time in this format: YYYY_MM_DD_HHMM ("Date/Time").
Keyboard help text	When set to On, every time you enter the keyboard screen a pop-up explains how to use the keyboard. When set to Off, no pop-up appears as you enter the keyboard screen, but you can still use the Help key (?) at any time.

TABLE CONTINUED ON NEXT PAGE

MENU ITEM	DESCRIPTIONS
Remember Last View	When set to On, when you select a menu from the Main Menu screen, you will be returned to the screen you were on before you last exited that menu. When set to Off, each time you select a menu from the Main Menu screen, you will go to the selected root menu. It does not matter what you did the last time you used that menu.
Delete Cache File	This item is different from the other HHP items, because it is a procedure instead of an adjustable setting. The first time you connect the programmer to a system, menu cache files are created. If you encounter problems when connecting, you can delete the cache files and retry connecting. To delete the cache files, select this item and press the right-arrow key ().
Date & Time	This folder contains eight items. Show Date/Time in header. The date and time are typically displayed at the top of the Main Menu screen. However, if you do not use batteries in the handheld programmer and there is no real-time clock in the connected control system, you can set this item to "Off," since it would not provide accurate information. 12h/24h. Here you can select the format used to display the time. Date Format. Several options are available: the year appearing first or last, and the month appearing before the day or the day appearing before the month. Year, Month, Day, Hour, and Minute allow you to set the date and the time for your time zone.
About	This folder contains information about the programmer similar to what is shown in the System Info menu for each of the modules in the control system: model number, software version, hardware version, serial number, etc.

PLOT & LOG

The *Plot & Log* menu selection allows the user, with the Plot program, to plot real-time variables on the CDT display screen; or, with the Log program, to create a log file of variable values to view later in a spreadsheet program on a PC.

The first step is to add the desired items to the Plot Variable List or the Log Variable List. While in the *Monitor* menu or *Parameters* menu, highlight an item and press the "Add to" softkey. In the next screen, highlight Plot or Log and press the "Select" softkey to view the list. To add the item to the list, press the "Add" softkey followed by the "Finish" softkey; you can include up to five items. To remove an item from a Variable List, select it and press the "Delete" softkey.

PLOT

In the Plot Variables list, a colored circle beside each variable shows the color that will be used to represent that variable in the plot. The colors are in a fixed order. If you want to use specific colors for specific variables, use the "Move Down" and "Move Up" softkeys to achieve the desired combinations. Use the left-arrow key to return to the Plot & Log menu.

To open the plotting program, highlight Plot and press the right-arrow key. The vertical axis is always used for the variables being plotted, and the horizontal axis is always used for time. For On/Off items, On = 1 and Off = 0 on the plot. Press the "Start" softkey to begin plotting data. Press the "Stop" softkey to stop plotting data and freeze the plot. You have the option of pressing the "Start" softkey to resume the plot.

LOG

To create a log of the items in your Log Variable List, highlight Log and press the right-arrow key. Then, in the "Start Logging" window, press the "OK" softkey. Select the location where you want to save the .xls file, and after pressing the "Save As" softkey and naming the .xls file, press the "OK" softkey. The display will now show the Plot & Log menu with a flashing red dot next to Log, indicating that logging is in progress. To stop logging, press the right-arrow key, and then in the "Stop Logging" screen, press the "OK" softkey.

CDT TROUBLESHOOTING

In the event that the handset does not function as described in this manual, the following troubleshooting guide should be studied and the referenced test procedures should be performed to troubleshoot the handset.

TROUBLESHOOTING GUIDE		
SYMPTOM	POSSIBLE CAUSES	CORRECTIVE ACTION
Handset display screen is blank	Handset cord and/or adaptor is disconnected	See Plugging the CDT into the Vehicle on page 11-2 .
	Vehicle batteries – loose terminals or corrosion	Section 14 — Batteries: IQ Plus Electric Vehicles
	Vehicle batteries – improperly wired	Section 14 — Batteries: IQ Plus Electric Vehicles
	Vehicle batteries – batteries failed	Section 14 — Batteries: IQ Plus Electric Vehicles
	Vehicle batteries – batteries not fully charged	Section 14 — Batteries: IQ Plus Electric Vehicles
	Handset cord has failed	Test Procedure 1 – Handset Cord on page 11-28
	Handset cord adaptor has failed	Test Procedure 2 – Handset Cord Adaptor on page 11-29
	CDT port (mounted under instrument panel assembly) has failed	Test Procedure 3 – CDT Ports on page 11-29
	Contrast Setting is too light	See Backlight under <i>HHP Settings</i> menu
	Controller is in power-down mode (vehicle unused and not charged for 72 hours)	Connect charger or drive the vehicle a short distance and reconnect the handset to the vehicle
	Charger has been connected and charging for more than 10 minutes	Disconnect charger, wait 30 seconds and reconnect charger
	Loose vehicle wire harness connections	Test Procedure 3 – CDT Ports on page 11-29
	Speed controller malfunction	Section 12 — Electrical System Troubleshooting: IQ Plus Electric Vehicles
Handset has failed	Replace handset	

TABLE CONTINUED ON NEXT PAGE

TROUBLESHOOTING GUIDE		
SYMPTOM	POSSIBLE CAUSES	CORRECTIVE ACTION
Display screen shows jumbled or undecipherable characters	Speed controller malfunction	Section 12 — Electrical System Troubleshooting: IQ Plus Electric Vehicles
	Handset malfunction	Disconnect the CDT cord from the vehicle. Wait a few seconds and reconnect the handset to the vehicle
	Loose connection at CDT port	Test Procedure 3 – CDT Ports on page 11-29
	Intermittent handset cord failure	Test Procedure 1 – Handset Cord on page 11-28
	Intermittent handset cord adaptor failure	Test Procedure 2 – Handset Cord Adaptor on page 11-29
	Loose vehicle wire harness connections	Test Procedure 3 – CDT Ports on page 11-29
Handset is “locked-up” – buttons do not respond	Handset malfunction	Disconnect the CDT cord from the vehicle. Wait a few seconds and reconnect the handset to the vehicle
	Vehicle batteries – loose terminals or corrosion	Section 14 — Batteries: IQ Plus Electric Vehicles
	Vehicle batteries – improperly wired	Section 14 — Batteries: IQ Plus Electric Vehicles
	Vehicle batteries – batteries failed	Section 14 — Batteries: IQ Plus Electric Vehicles
	Vehicle batteries – batteries not fully charged	Section 14 — Batteries: IQ Plus Electric Vehicles
	Speed controller malfunction	Section 12 — Electrical System Troubleshooting: IQ Plus Electric Vehicles

CONNECTION TESTS

⚠ WARNING

- If wires are removed or replaced, make sure wiring and wire harness is properly routed and secured. Failure to properly route and secure wiring could result in vehicle malfunction, property damage, personal injury, or death.

Index of Test Procedures

- 1 – Handset Cord
- 2 – Handset Cord Adaptor
- 3 – CDT Ports

TEST PROCEDURE 1 – Handset Cord

See General Warnings on page 1-1.

1. Using a multimeter set for 200 ohms, place the red (+) probe into one of the terminals on the end of the cord with the square plug.
2. Place the black (–) probe on each of the pins, one at a time, on the plug on the other end of the cord.
3. The multimeter should indicate continuity on only one pin. If any other reading is obtained, the cord must be replaced.
4. Repeat the procedure three more times, each time with the red (+) probe inserted into a different terminal on the end of the cord with the square plug.

TEST PROCEDURE 2 – Handset Cord Adaptor

See General Warnings on page 1-1.

The procedure for testing the handset cord adaptor is similar to the cord test.

1. Using a multimeter set for 200 ohms, place the red (+) probe into one of the terminals on the end of the adaptor with the square plug.
2. Place the black (–) probe on each of the pins, one at a time, on the other plug of the adaptor.
3. The multimeter should indicate continuity on only one pin. If any other reading is obtained, the adaptor must be replaced.
4. Repeat the procedure three more times, each time with the red (+) probe inserted into a different terminal on the end of the adaptor with the square plug.

TEST PROCEDURE 3 – CDT Ports

Inspect the CDT ports for damage or corrosion.

3A – CDT PORT (LOCATED UNDER INSTRUMENT PANEL)

See General Warnings on page 1-1.

1. Turn the key switch to the OFF position, place the Forward/Reverse switch in the NEUTRAL position, and lock the park brake.
2. Disconnect the batteries and discharge the controller. **See Disconnecting the Batteries – Electric Vehicles, Section 1, Page 1-4.**
3. Check the CDT port mounted under the steering wheel.
 - 3.1. Remove the instrument panel. **See Instrument Panel Removal, Section 4, Page 4-10.**
 - 3.2. Disconnect the CDT port four-pin connector from the main wire harness and visually inspect the contacts for damage and corrosion. Inspect the CDT port mounted to the bottom of the dash panel. Repair and replace parts as necessary.
 - 3.3. If no problem is found, connect the four-pin connector and install the center dash panel.
 - 3.4. Connect the batteries. **See Connecting the Batteries – Electric Vehicles, Section 1, Page 1-4.**
 - 3.5. Align the keyed portion of the CDT plug with the CDT port and connect. If the handset fails to function, **see CDT Troubleshooting on page 11-27.**

3B – CDT PORT (LOCATED ON CONTROLLER)

See General Warnings on page 1-1.

1. Check the CDT port on the speed controller.
 - 1.1. Remove the controller access panel.
 - 1.2. Disconnect the square four-pin connector (1) from the speed controller.

- 1.3. Connect the handset cord to the handset.
- 1.4. Connect the other end of the handset cord (without the adapter) to the four-pin connector of the speed controller.
- 1.5. Connect the vehicle batteries, positive (+) cable first.

If the handset does not function during Test Procedure 3A, but does function when connected directly to the speed controller, the handset cord adapter and vehicle wire harness should be thoroughly tested. **See Test Procedure 2 – Handset Cord Adaptor on page 11-29.** The CDT ports and connections should also be thoroughly checked. Section 12 — Electrical System Troubleshooting: IQ Plus Electric Vehicles

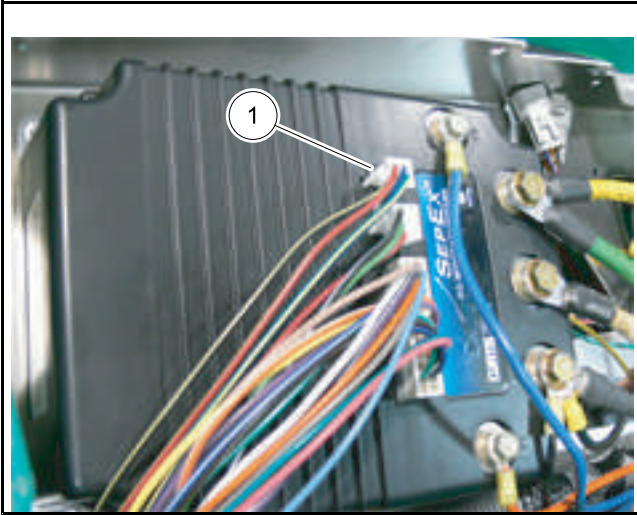

Figure 11-3 Disconnect Four-pin Connector.

⚠ DANGER

- See General Warnings on page 1-1.

⚠ WARNING

- See General Warnings on page 1-1.

GENERAL INFORMATION

The IQ Plus vehicle uses a 48-volt electrical system with a shunt-wound, 3.7 hp motor that is powered by eight 6-Volt, lead-acid batteries and charged by a high-frequency charger. Several additional features include the following:

ACCESSORIES

For powered accessories that need to be controlled by the key switch, use the 12-volt power strip located under the cowl.

CHARGE INDICATOR LIGHT

IQ Plus vehicles with QuiQ Charger system feature a dash mounted charge indicator light (below the steering column) that serves two functions: 1) Battery low state of charge warning, and 2) Charging confirmation. The charge indicator light is controlled by pin 11 of the controller.

Battery Low State of Charge Warning

- The light comes on and remains solid when the battery state of charge falls below 20%.
- The light begins flashing when the battery state of charge falls below 10%.

Charging Confirmation

- The light will flash three times and the reverse buzzer simultaneously will sound three times to indicate a battery charging session has begun. **See following NOTE.**

NOTE: *The number of flashes and beeps can vary depending on the Beep Option setting. See Beep Option, Section 11, Page 11-9.*

KEY DIFFERENCES: IQ PLUS WITH QUIQ CHARGER VS. IQ PLUS CHARGER

- Utilizes the 1520L-5550 controller (gold label) instead of the 1520-5501 (silver label).
- The onboard computer (OBC) is no longer used.
- New main wire harness that uses a 10k ohm pull-up resistor for the charger interlock circuit.
- New B- wire assembly, which replaces the one integral to the onboard computer (OBC). With the OBC gone, the new B- wire assembly is needed to connect the B- terminal of the controller to the negative (-) post of battery no. 8 (8 x 6-Volt battery set).
- New battery charge indicator light in the instrument panel. This light is an LED and is used to confirm when a charge cycle begins and when the battery pack has reached a low state of charge.
- A new controller is used that has data collecting functions previously performed by the OBC. Pin 22 in the 24-pin connector is now utilized to operate the charge indicator light in the instrument panel.

- The controller tracks amp-hour usage for fleet management and warranty administration.
- No Communication Display Module (CDM) required. Use only the IQ Display Module (CDT).
- The CDT will remain ON for approximately 10 minutes when the charger is connected.
- Improved charger and battery state of charge (SoC) status indication.
- Battery charger algorithm can be changed in the field instead of changing an onboard computer (OBC).
- B+ red wire of charger wire harness connects directly to the solenoid to reduce potential corrosion.

FEATURES

- **Shunt-Wound Motor:** The shunt-wound motor, unlike a series motor, is designed so that the speed controller is able to vary the amount of current passing through the field coils independently from the current passing through the armature.
- **Motor Braking:** Under certain conditions a shunt-wound motor also has the ability to act as an electrical brake to slow the vehicle. There are three features of the IQ Plus electrical system which will activate the motor braking function: Walk Away Braking, Pedal Down Motor Braking, and Pedal Up Motor Braking (adjustable with the CDT handset).
- **Walk Away Braking:** the walk away braking feature will prevent the vehicle from rolling at more than 1 or 3 mph (1.5 or 4.8 km/h) unless the accelerator is pressed. This prevents the possibility of a parked vehicle (with the park brake disengaged) rolling away too fast to be overtaken on foot. If the walk away braking function remains engaged for two seconds or more, a warning buzzer will sound to alert the driver that motor braking has been activated.

WARNING

- **Walk away braking will not limit vehicle speed to 1 mph (1.6 km/h) on very steep grades. Do not operate vehicle on slopes exceeding 20% grades.**
- **Pedal Down Motor Braking:** This feature helps to control vehicle downhill speed. Motor braking is activated when the vehicle reaches the programmed top speed and holds the vehicle at that speed. Motor braking is automatically disengaged when vehicle speed slows below the programmed top speed.
- **Pedal Up Motor Braking (adjustable):** Speed settings are programmable for IQ Plus vehicles. Motor braking is activated when the accelerator pedal is released at or above the programmed speed. When the vehicle slows to the programmed lower speed, motor braking will disengage. If no speed settings are programmed, motor braking will be activated at any time accelerator is released, and it will only disengage when the vehicle comes to a stop. Contact your Club Car dealer/distributor to inquire about this programmable feature.
- **Regenerative Braking:** When motor braking is activated, the vehicle motor acts as a generator, slowing the vehicle as it creates energy that is used to charge the batteries.
- **Run/Tow Switch:** When the Run/Tow switch is in the RUN position, the vehicle will function normally. When the switch is in the TOW position, power to the OBC and controller is shut off, disabling the vehicle operating circuit and walk away braking, allowing the vehicle to be towed.
- **Speed Calibration:** This function allows the vehicle's top speed to be calibrated in 0.1 mph (0.2 km/h) increments. **See M1/M2 Speed Cal, Section 11, Page 11-7.**
- **Motor Protection Circuit:** The operator should never attempt to hold the vehicle on an incline by pressing the accelerator pedal instead of the brake pedal, as motor overheating could result. By reducing the current to the motor during such an occurrence, the motor protection circuit reduces the possibility of motor damage. When this situation arises, a *motor stall fault* is recorded by the speed controller and will be displayed on an CDT handset in the Diagnostic History menu. **See CDT Troubleshooting, Section 11, Page 11-27.**
- **High Pedal Detect:** This function prevents unexpected vehicle movement if the key switch is turned ON after the accelerator is pressed or the Forward/Reverse switch is used to change the direction of travel while the vehicle is being driven. The vehicle slowly comes to a controlled stop, then starts to gradually accelerate in the new direction.

If either situation arises, an *HPD fault* is recorded by the speed controller and will be displayed on an CDT handset in the Diagnostic History menu. **See CDT Troubleshooting, Section 11, Page 11-27.**

WIRING DIAGRAMS

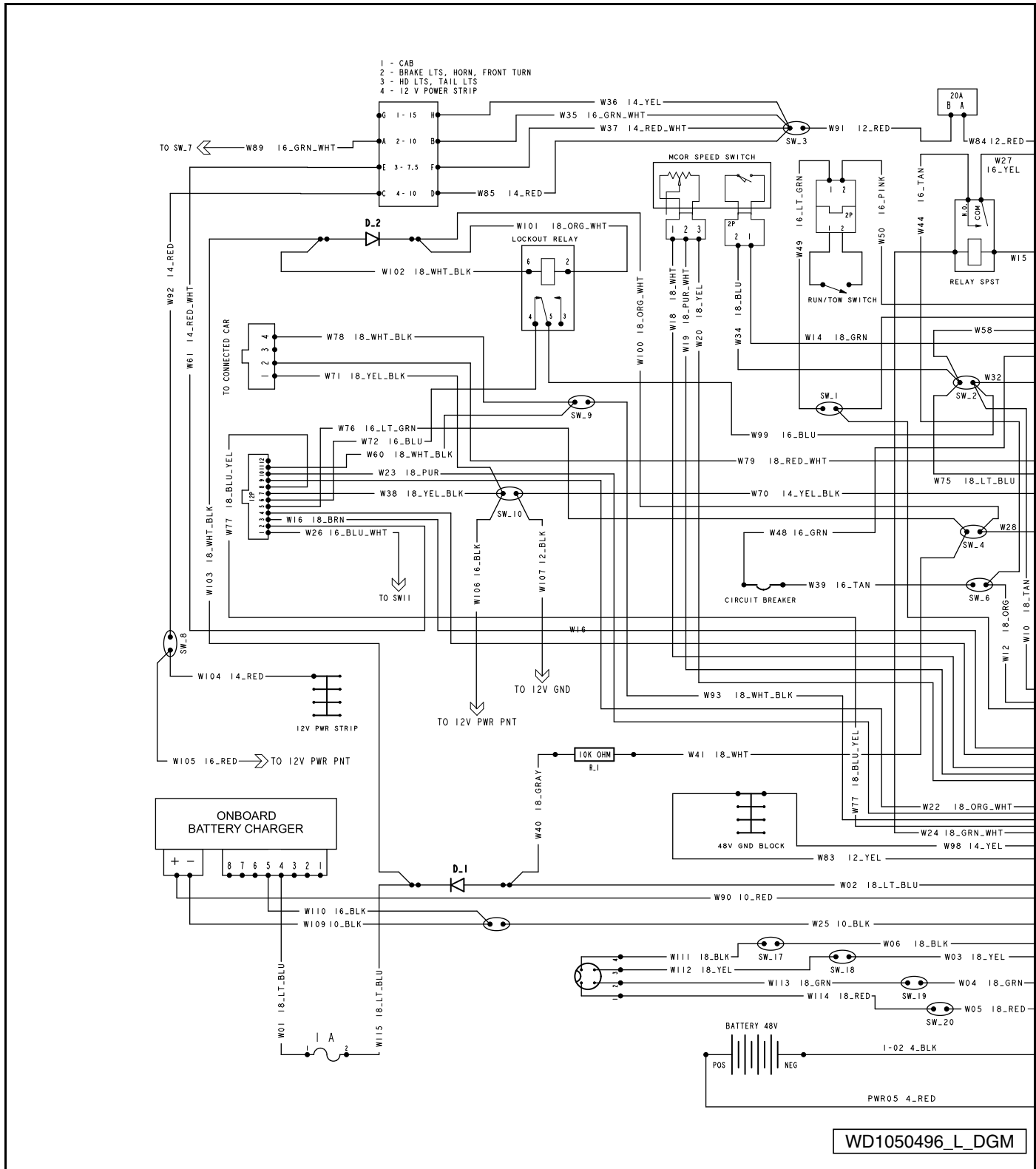
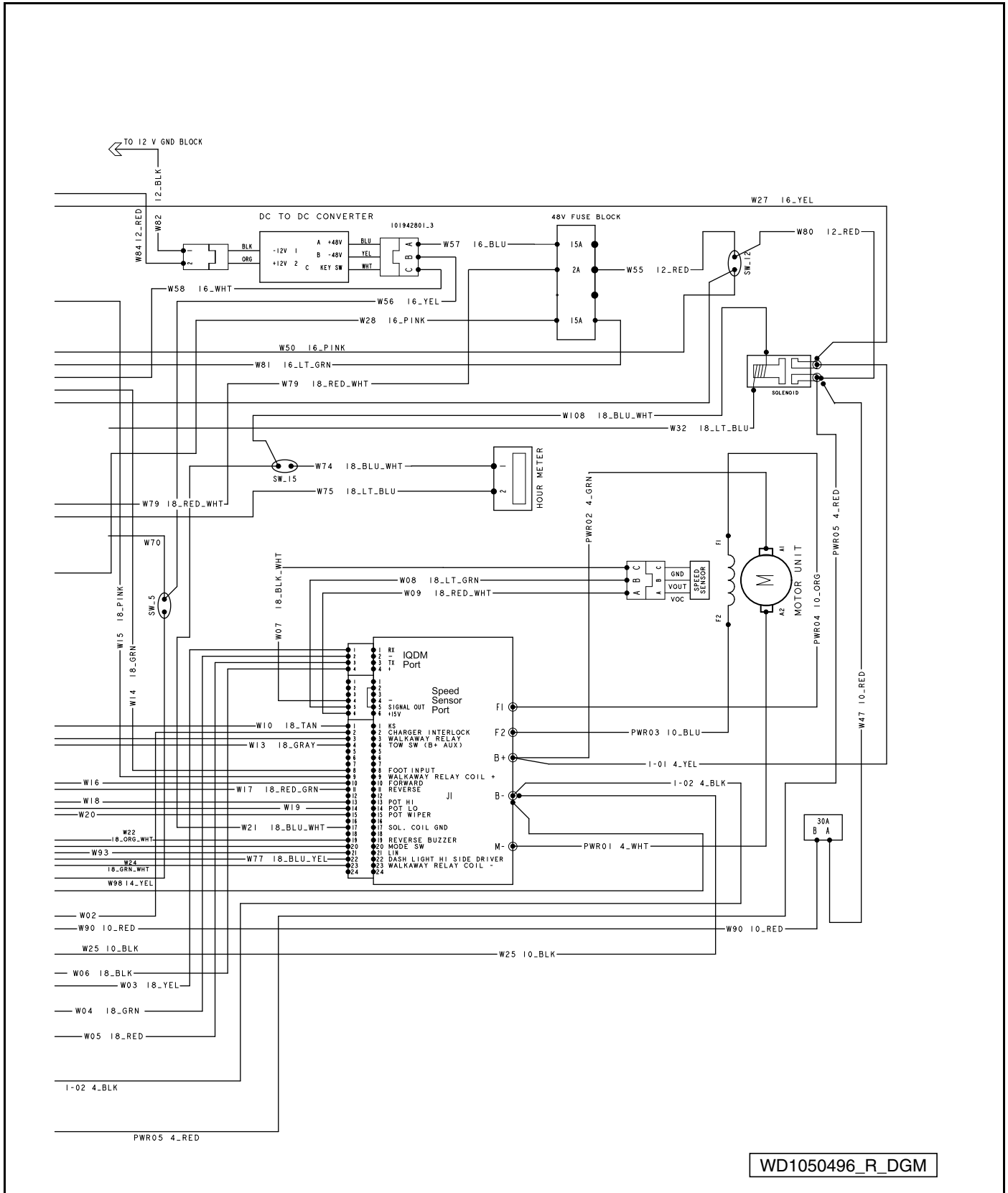
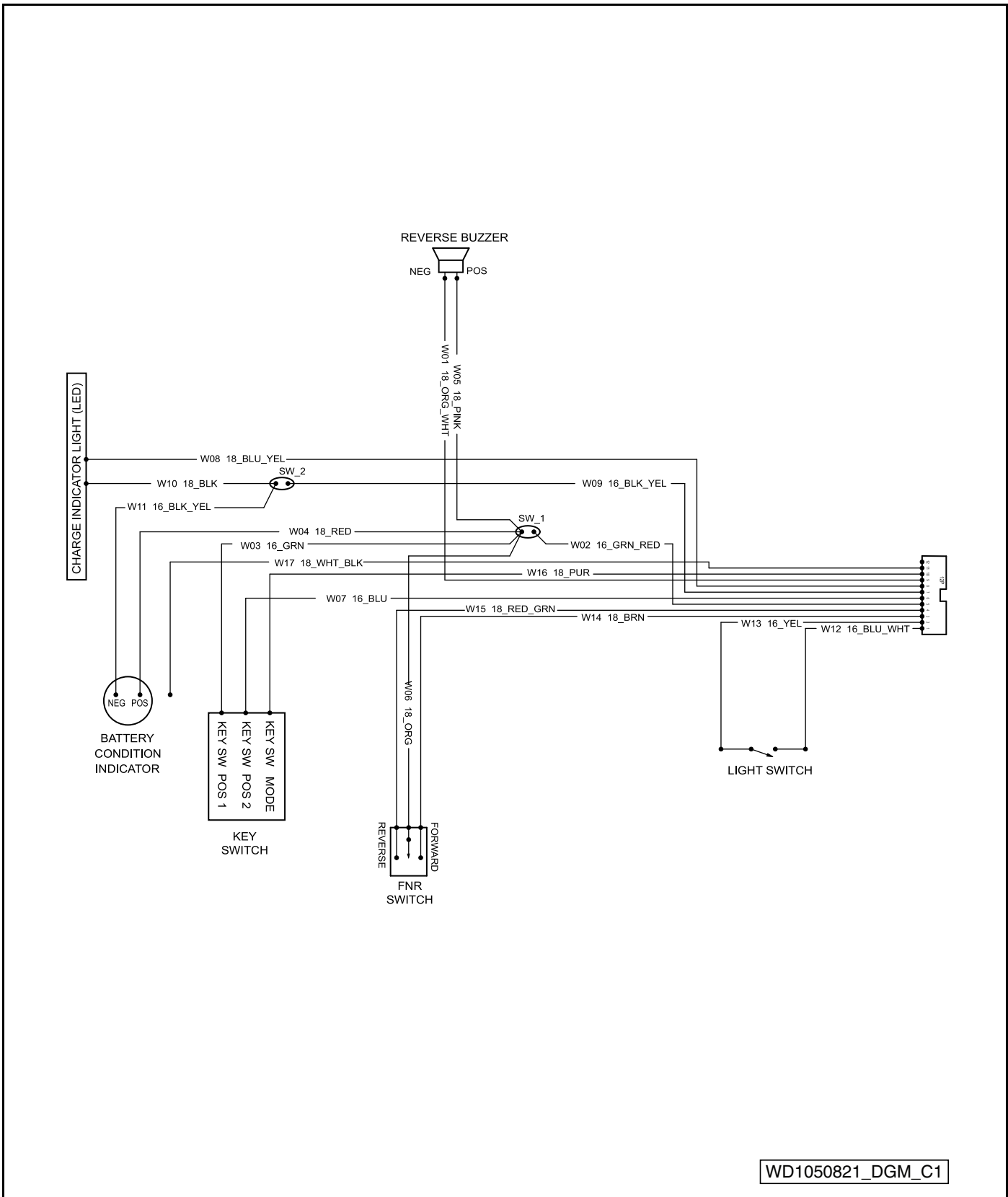

Figure 12-1 Wiring Diagram



WD1050496_R_DGM

Figure 12-2 Wiring Diagram (Continued)



WD1050821_DGM_C1

Figure 12-3 Wiring Diagram – Instrument Panel

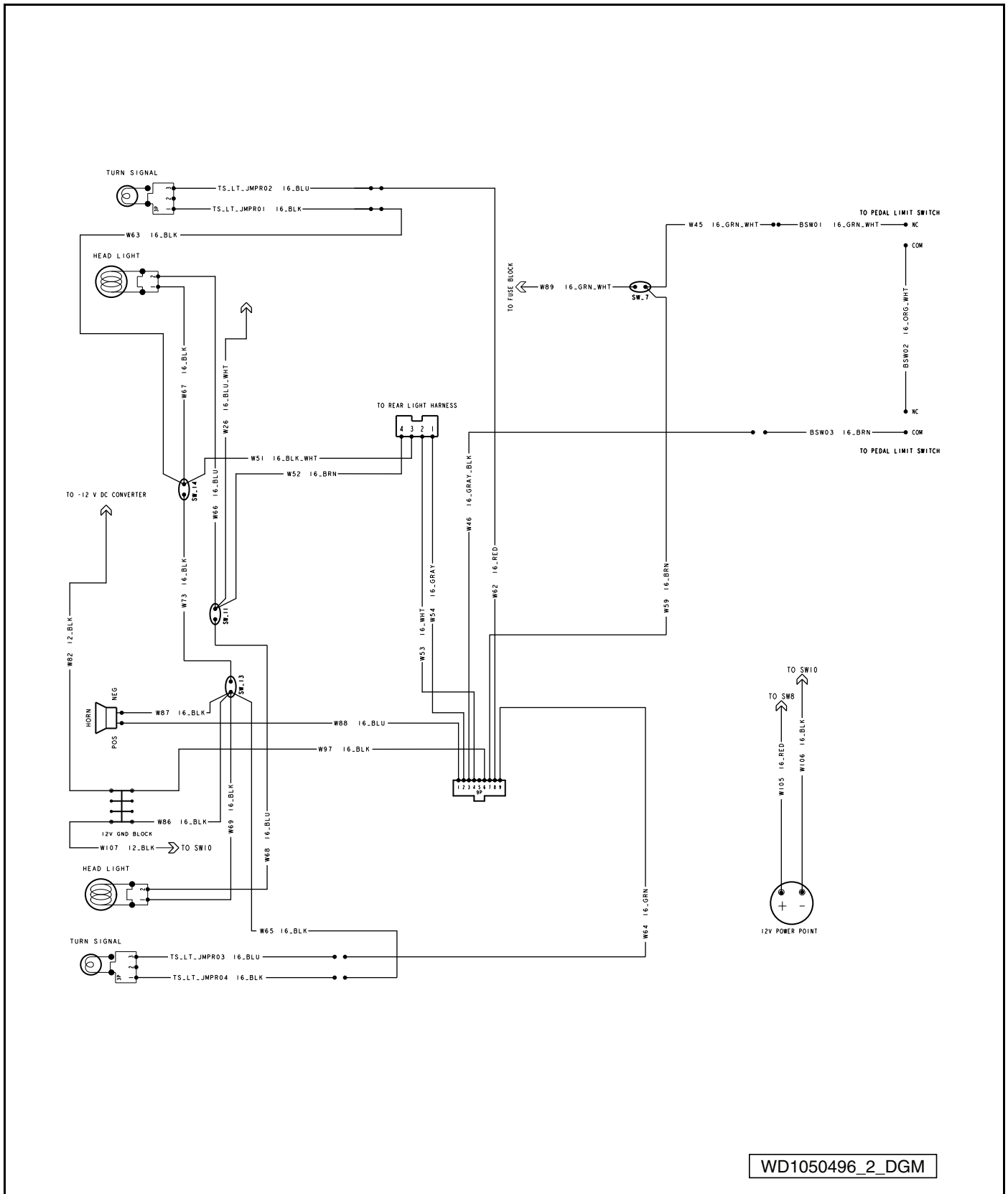

WD1050496_2_DGM

Figure 12-4 Wiring Diagram – Accessories

TROUBLESHOOTING

The following troubleshooting guides will be helpful in identifying operating difficulties should they occur. The guides include the symptom, probable cause(s) and suggested checks. The procedures used in making these checks can be found in the referenced sections of this maintenance and service supplement.

TROUBLESHOOTING THE VEHICLE WITH THE CDT

Club Car recommends the use of the CDT handset for troubleshooting vehicles equipped with the IQ Plus electrical system. Troubleshooting Guide 1 is to be used in conjunction with the CDT handset. Refer to the CDT Owner's Manual for operating instructions. **See following WARNING.**

WARNING

- **The vehicle operator should not monitor the CDT while the vehicle is in motion. A technician can monitor the CDT while traveling as a passenger in the vehicle. Failure to heed this warning could result in severe personal injury or death.**

In the event that the vehicle is not functioning properly after completing Troubleshooting Guide 1, the technician should proceed to Troubleshooting Guide 2.

If an CDT handset is unavailable, the technician should proceed to Troubleshooting Guide 2.

TROUBLESHOOTING GUIDE 1

The following troubleshooting guide is intended for use with an CDT handset. For CDT operating instructions, refer to the CDT Owner’s Manual. **See following NOTE.**

NOTE: Before troubleshooting the vehicle, check the diagnostic history from the Special Diagnostics Menu. Note any fault codes.

TROUBLESHOOTING GUIDE 1		
SYMPTOM	POSSIBLE CAUSES	CORRECTIVE ACTION
Monitor Menu – THROTTLE % value does not increase as the accelerator pedal is pressed or Diagnostic Menu – THROTTLE FAULT 1 fault code	Loose or disconnected three-pin connector at the MCOR or broken wire	Repair and/or connect the three-pin connector to the MCOR
	Loose or disconnected 24-pin connector at speed controller or broken wire	Repair and/or connect the 24-pin connector to the speed controller
	Failed MCOR	Test Procedure 12 – MCOR Voltage on page 12-27
Monitor Menu – HEATSINK °C indicates that temperature is above 85 °C (145 °F) or Diagnostic Menu – THERMAL CUTBACK fault code	Over-adjusted brakes	See Wheel Brake Assemblies Section
	Vehicle is over-loaded	Ensure that vehicle is not over-loaded before returning to operation
Monitor Menu – ARM PWM value does not reach 100% when vehicle is at full speed	Failed MCOR	Test Procedure 12 – MCOR Voltage on page 12-27
	Improper pedal group adjustment	See Accelerator and Brake Pedal Group Section
Monitor Menu – SPEED PULSES menu item indicates that speed pulses are OFF when the vehicle is in motion or Diagnostic Menu – SPEED SENSOR fault code	Loose or disconnected motor speed sensor or broken wire	Repair and/or connect the three-pin connector to the motor speed sensor
	Loose or disconnected 24-pin connector at speed controller or broken wire	Repair and/or connect the 24-pin connector to the speed controller
	Failed motor speed sensor or failed magnet	Test Procedure 13 – Motor Speed Sensor on page 12-29
Monitor Menu – FOOT INPUT menu item indicates that the MCOR internal limit switch is always ON or always OFF.	Loose or disconnected two-pin connector at the MCOR or broken wire	Repair and/or connect the two-pin connector to the MCOR
	Loose or disconnected 24-pin connector at speed controller or broken wire	Repair and/or connect the 24-pin connector to the speed controller
	Failed MCOR limit switch	Test Procedure 7 – Key Switch and MCOR Limit Switch Circuit on page 12-23
Monitor Menu – FORWARD INPUT and/or REVERSE INPUT does not indicate the correct reading or Diagnostic Menu – PROC/WIRING fault code	Loose or disconnected Forward/Reverse rocker switch (quick disconnect terminals) or broken wire	Repair and/or connect the quick disconnect terminals to the Forward/Reverse switch
	Loose or disconnected Forward/Reverse rocker switch (three-pin connector) or broken wire	Repair and/or connect the three-pin connector from the Forward/Reverse switch to the wire harness
	Loose or disconnected 24-pin connector at speed controller or broken wire	Repair and/or connect the 24-pin connector to the speed controller
	Failed Forward/Reverse rocker switch	Test Procedure 8 – Forward/Reverse Rocker Switch on page 12-24

TABLE CONTINUED ON NEXT PAGE

TROUBLESHOOTING GUIDE 1		
SYMPTOM	POSSIBLE CAUSES	CORRECTIVE ACTION
Monitor Menu – MAIN CONT (solenoid) does not indicate ON when the solenoid should be activated. or Diagnostic Menu – MAIN CONT DNC (main contactor (solenoid) did not close) fault code	Speed controller logic malfunction	Disconnect the batteries and allow the speed controller capacitors to discharge. See WARNING “To avoid unintentionally starting...” in See General Warnings on page 1-1 . Reconnect the batteries and see if the symptom returns.
	Failed controller FET (that powers up solenoid coil)	
	Loose, broken, or disconnected wire(s) at solenoid or B+ speed controller terminal	Repair and/or connect the loose or disconnected wire(s)
	Loose or disconnected 24-pin connector at speed controller or broken wire	Repair and/or connect the 24-pin connector to the speed controller
	Failed solenoid	Replace solenoid. See Solenoid Removal on page 13-8 .
Monitor Menu – KEY INPUT does not indicate ON when key switch is in the ON position	Loose or disconnected wires at key switch terminals or broken wire	Repair and/or connect the quick disconnect terminals to the Forward/Reverse switch
	Loose or disconnected 24-pin connector at speed controller or broken wire	Repair and/or connect the 24-pin connector to the speed controller
	Failed key switch	Test Procedure 7 – Key Switch and MCOR Limit Switch Circuit on page 12-23
Diagnostic Menu – THROTTLE FAULT 1 fault code	Loose or disconnected three-pin connector at the MCOR or broken wire	Repair and/or connect the three-pin connector to the MCOR
	Loose or disconnected 24-pin connector at speed controller or broken wire	Repair and/or connect the 24-pin connector to the speed controller
	Failed MCOR	Test Procedure 12 – MCOR Voltage on page 12-27
Diagnostic Menu – HW FAILSAFE (Hardware Failsafe) fault code	Armature drive FET's (field-effect transistors) inside speed controller have failed	Replace the speed controller. See Speed Controller Removal on page 13-9 .
	Speed controller logic malfunction	Disconnect the batteries and allow the speed controller capacitors to discharge. See WARNING “To avoid unintentionally starting...” in See General Warnings on page 1-1 . Reconnect the batteries and see if the symptom returns.
Diagnostic Menu – MAIN WELDED (main solenoid contacts welded) fault code	Solenoid contacts have failed closed	Replace solenoid. See Solenoid Removal on page 13-8 .
Diagnostic Menu – MAIN DRIVER ON or MAIN DRIVER OFF fault code	Speed controller logic malfunction	Disconnect the batteries and allow the speed controller capacitors to discharge. See WARNING “To avoid unintentionally starting...” in See General Warnings on page 1-1 . Reconnect the batteries and see if the symptom returns.
	Failure of the FET that controls the solenoid coil	Replace the speed controller. See Speed Controller Removal on page 13-9 .
Diagnostic Menu – MAIN COIL FAULT fault code or Diagnostic Menu – MAIN DROPOUT fault code	Solenoid coil has failed in an open condition or broken wire to solenoid coil	Replace solenoid. See Solenoid Removal on page 13-8 .

TABLE CONTINUED ON NEXT PAGE

TROUBLESHOOTING GUIDE 1		
SYMPTOM	POSSIBLE CAUSES	CORRECTIVE ACTION
Diagnostic Menu – FIELD MISSING fault code	Loose or disconnected motor field coil wires at motor or speed controller or broken wire	Repair and/or connect the field coil wires
	Failure of the motor field windings	Section 16 — Motor (Model DA5-4006): Electric Vehicles
	Failure of the FET's that control field current	Replace the speed controller. See Speed Controller Removal on page 13-9.
Diagnostic Menu – HPD (high pedal detect) fault code	Operator error	Train operators to fully remove foot from accelerator pedal before turning key switch to the ON position or changing the selected direction with the Forward/Reverse switch
Diagnostic Menu – LOW BATTERY fault code	Batteries require charging	Place batteries on battery charger and allow them to fully charge
	Improperly maintained or failed batteries	Section 14 — Batteries: IQ Plus Electric Vehicles
Diagnostic Menu – MOTOR STALL fault code	Operator error	Train operators to use the brake to hold the vehicle on a hill, rather than holding the vehicle on a hill using the accelerator pedal.
Diagnostic Menu – OPEN ARMATURE fault code	Loose or disconnected motor armature wires at motor or speed controller or broken wire	Repair and/or connect the motor armature wires
	Failure of the motor armature or brushes	Section 16 — Motor (Model DA5-4006): Electric Vehicles
	Failure of the FET's that control armature current	Replace the speed controller. See Speed Controller Removal on page 13-9.

TROUBLESHOOTING GUIDE 2

TROUBLESHOOTING GUIDE 2		
SYMPTOM	POSSIBLE CAUSES	CORRECTIVE ACTION
Vehicle does not operate	Batteries discharged	Charge batteries
	Improper or poor battery connections	Check vehicle wiring. See Wiring Diagrams beginning on page 12-4
	Battery charger is connected to the vehicle – Solenoid lockout feature has disabled the vehicle	Disconnect the battery charger from the vehicle
	Key switch and MCOR limit switch circuit	Check for loose or disconnected wires at key switch and MCOR
	Failed key switch	Test Procedure 7 – Key Switch and MCOR Limit Switch Circuit on page 12-23
	Failed MCOR	Test Procedure 7 – Key Switch and MCOR Limit Switch Circuit on page 12-23 See also Test Procedure 12 – MCOR Voltage on page 12-27
	Forward/Reverse rocker switch	Test Procedure 8 – Forward/Reverse Rocker Switch on page 12-24
	Solenoid – loose wires	Test Procedure 9 – Solenoid Activating Coil on page 12-25
	Solenoid – failed coil	Test Procedure 9 – Solenoid Activating Coil on page 12-25
	Solenoid – failed solenoid diode	Test Procedure 9 – Solenoid Activating Coil on page 12-25
	Speed controller thermal cutback	Allow controller to cool and ensure that vehicle is not over-loaded before returning to operation
	24-pin connector at speed controller	Check for loose or disconnected wires at the 24-pin connector. See also Test Procedure 15 – 24-Pin Connector on page 12-33.
	High pedal detect	Cycle accelerator pedal
	Motor stall	Cycle accelerator pedal
	Motor failure	Section 16 — Motor (Model DA5-4006): Electric Vehicles
Failed Run/Tow switch	Test Procedure 3 – Run/Tow Switch on page 12-18	
Speed controller failure	Replace speed controller. See Speed Controller Removal on page 13-9.	

TABLE CONTINUED ON NEXT PAGE

TROUBLESHOOTING GUIDE 2		
SYMPTOM	POSSIBLE CAUSES	CORRECTIVE ACTION
Vehicle runs slowly	Speed sensor disconnected or failed	Test Procedure 13 – Motor Speed Sensor on page 12-29
	Incorrect speed setting	To change the programmed top speed of the vehicle, an CDT handset must be used
	Wiring – improperly wired	Check vehicle wiring. See Wiring Diagrams beginning on page 12-4
	Batteries discharged	Charge batteries
	MCOR malfunction	Test Procedure 12 – MCOR Voltage on page 12-27
	Motor – loose wires	Inspect and tighten all wire connections at the motor
	Failed motor	Replace motor. See Motor Removal on page 16-2.
	Vehicle is over-loaded	Ensure that vehicle is not over-loaded before returning to operation
	Speed controller failure	Replace speed controller. See Speed Controller Removal on page 13-9.
	Brakes – improperly adjusted	See Wheel Brake Assemblies Section.
Tires – under-inflated or flat tires	See Wheels and Tires Section.	
Vehicle operates, but motor braking function does not	Wiring – improperly wired	Check vehicle wiring. See Wiring Diagrams beginning on page 12-4
	Speed sensor disconnected or failed	Test Procedure 13 – Motor Speed Sensor on page 12-29
Vehicle will run in forward, but not in reverse or will run in reverse but not forward	Forward/Reverse rocker switch – improperly wired	Test Procedure 8 – Forward/Reverse Rocker Switch on page 12-24
	Motor – improperly wired	Check motor wiring. See Wiring Diagrams beginning on page 12-4
	Speed controller – improperly wired or failed speed controller FET	Check vehicle wiring. See Wiring Diagrams beginning on page 12-4
Vehicle operates, but battery charger does not charge batteries	Charger interlock failure	Test Procedure 11 – Charger Interlock on page 12-26
	Battery charger connections – loose wires at charger or batteries	Check wire connections and tighten if necessary.
	Battery charger	Section 15 — QuiQ High Frequency Charger

TEST PROCEDURES

Using the following procedures, the entire IQ Plus electrical system can be tested without major disassembly of the vehicle. **See following WARNING.**

⚠ WARNING

- **If wires are removed or replaced, make sure wiring and wire harness is properly routed and secured. Failure to properly route and secure wiring could result in vehicle malfunction, property damage, personal injury, or death.**

TESTING BASICS

- To use the CDT, the Run/Tow switch must be in the RUN position. The Run/Tow switch provides power to the logic board and power board inside the controller.
- Battery Pack Voltage (BPV) will be referenced throughout the test procedures. BPV is accessed in **Test Procedure 1 – Batteries / Voltage Check (BPV) on page 12-15.**
- The Run/Tow switch powers the key switch, controller, Forward/Reverse switch, 15-amp fuse, and reverse buzzer.
- The key switch powers the MCOR 2-pin circuit, pin 1 of the 24-pin connector, solenoid, and the 12-Volt power strip.
- The MCOR 3-pin circuit, motor speed sensor circuit, the communication point for the connected car device (white/black wire in position 21 of the 24-pin connector), and charge indicator light is powered by the controller (with Run/Tow switch in RUN).
- The 2-amp fuse is powered directly by the batteries via the solenoid and carries BPV to the connected car device. No switch is involved.
- The term “back-probe” refers to probing the side of a connector that the wire enters. This is usually done when the connector must remain connected to a device. **See following CAUTION.**

CAUTION

- **Be careful not to damage the wire or terminal when back-probing.**
- When testing voltage, the batteries must remain connected.
- When testing voltage, unless specifically directed to do otherwise in a procedure, connect the black (–) probe of the multimeter to the negative post of battery no. 8 (6 x 8-Volt battery set) or the B- terminal of the controller, whichever is easier to access.
- When testing controller functions, the Run/Tow switch must be in the RUN position. The TOW position removes power to the controller.

Index of Test Procedures

- 1 – Batteries / Voltage Check (BPV)
- 2 – 48-Volt Battery Pack Voltage Under Load
- 3 – Run/Tow Switch
- 4 – Fuses
- 5 – Circuit Breaker
- 6 – Wire Harness Diodes
- 7 – Key Switch and MCOR Limit Switch Circuit
- 8 – Forward/Reverse Rocker Switch
- 9 – Solenoid Activating Coil
- 10 – Solenoid Contacts

- 11 – Charger Interlock
- 12 – MCOR Voltage
- 13 – Motor Speed Sensor
- 14 – A1 and A2 Motor Voltage
- 15 – 24-Pin Connector
- 16 – Reverse Buzzer
- 17 – Walk Away Braking Relay
- 18 – Charge Indicator Light
- 19 – 4-Pin Connector (for Connected Car Device)

TEST PROCEDURE 1 – Batteries / Voltage Check (BPV)

See General Warnings on page 1-1.

NOTE: *This is a voltage test.*

If battery voltage drops below 34 volts during operation, the vehicle will shut down and give a Low Battery Voltage/Undervoltage fault.

*The batteries must be properly maintained and fully charged in order to perform the following test procedures. Battery maintenance procedures, including watering information and allowable mineral content, can be found in the Battery section of this manual. See **Battery Care on page 14-6.***

The battery voltage can be displayed with the CDT handset. If an CDT handset is not available, proceed to **Batteries / Voltage Check without the CDT Handset.**

Batteries / Voltage Check with the CDT Handset

1. Connect the CDT to the vehicle.
2. Access the Monitor menu and select BATT VOLTAGE by using the SCROLL DISPLAY buttons. The CDT should indicate at least 48 volts. **See following NOTE.** If not, check for loose battery connections or a battery installed in reverse polarity. **Refer to Batteries: IQ Plus Electric Vehicles on page 14-1 for further details on battery testing.**

NOTE: *The voltage displayed through the CDT shows what the controller thinks it sees. If the controller is not operating properly, it may display a different voltage from what the battery pack voltage (BPV) really is. Always compare and confirm with readings obtained using a multimeter in the following procedure.*

Batteries / Voltage Check without the CDT Handset

1. If necessary, see Testing Basics on page 12-14.
2. With batteries connected and using a multimeter set to 200 volts DC, place red (+) probe on the positive (+) post of battery no. 1 and the black (–) probe on the negative (–) post of battery no. 6 (**Figure 12-5, Page 12-16**).
3. The multimeter should indicate at least 48 volts. If not, check for loose battery connections or a battery installed in reverse polarity. **Refer to Batteries: IQ Plus Electric Vehicles on page 14-1 for further details on battery testing.**

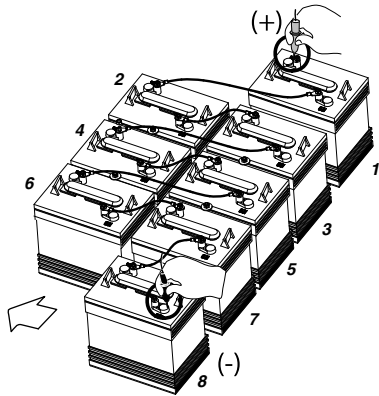

(Viewed from driver side of vehicle)

1. RED probe to battery no. 1 (+).
2. BLACK probe to battery no. 6 (-).

3072

Figure 12-5 Battery Voltage Test – 500/550/700

TEST PROCEDURE 2 – 48-Volt Battery Pack Voltage Under Load

See General Warnings on page 1-1.

NOTE: This is a voltage test.

1. If necessary, see Testing Basics on page 12-14.
2. Be sure the batteries are fully charged and that the electrolyte level is correct in all cells.
3. Connect the tester leads to the positive (+) post of battery no.1 and negative (-) post of battery no. 8 (Figure 12-6, Page 12-17).

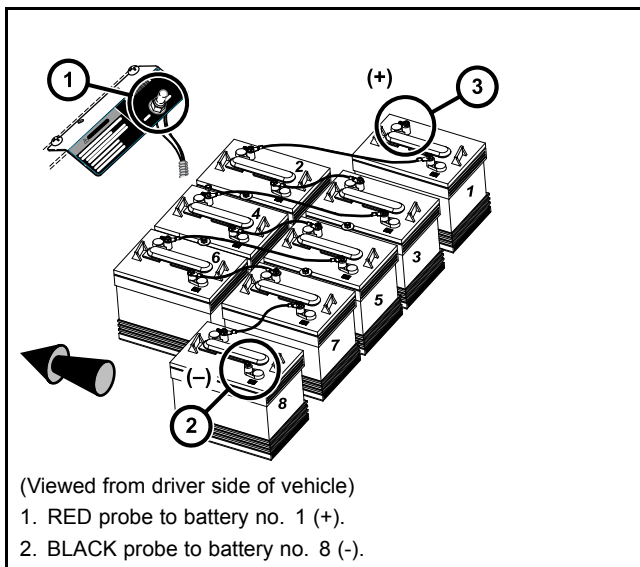

2780a

Figure 12-6 Battery Discharge Test

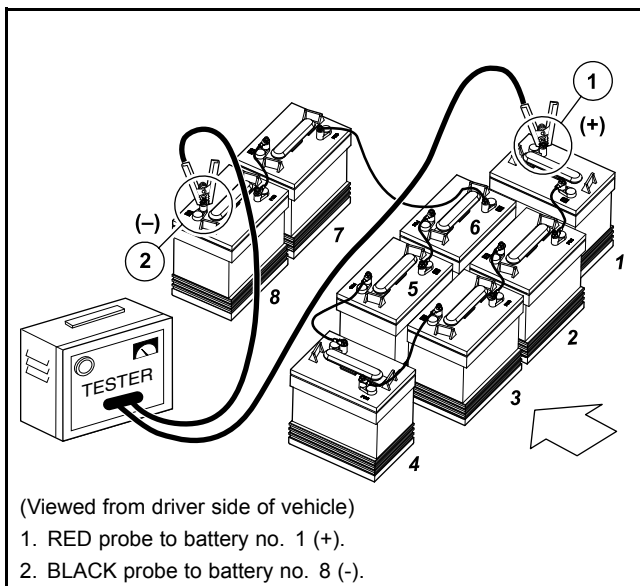

2781a

Figure 12-7 Battery Discharge Test

4. Turn the discharge machine on and record the voltage reading of battery pack while under load.

5. A fully charged set of batteries in good condition should read between 47 and 49 volts while under load.
6. A reading of 32 to 42 volts indicates discharged or failed batteries. Each battery should be checked with a multimeter while under load. **See following NOTE.**

NOTE: *If a 48-volt set of batteries is down in the 32 to 38 volt range, the discharge machine will activate but it will think it is testing a 36-volt battery set.*

7. A reading of 31.5 volts or less will not activate discharge machine. If the voltage of the batteries is below 32 volts, the batteries are deeply discharged or have failed.
8. Recording the battery pack voltage reading while under load provides a more accurate diagnosis of the condition of the batteries. When the discharge machine is ON, it places the battery pack under load and many times can help determine if one or more batteries in the set have failed. Testing battery voltage while the batteries are not under load will not always indicate the true condition of the batteries. For more information about the batteries, refer to Section 14 — Batteries: IQ Plus Electric Vehicles

TEST PROCEDURE 3 – Run/Tow Switch

See General Warnings on page 1-1.

NOTE: *This is a voltage test.*

If no voltage is coming to the Run/Tow Switch, inspect the 12-gauge red wire connection at the solenoid and sonic weld 12.

Run/Tow Switch Test with the CDT Handset

1. With the Run/Tow switch in the RUN position, connect the CDT to the vehicle. **See Plugging the CDT into the Vehicle on page 11-2.**
2. Immediately after the CDT is connected to the vehicle, the screen should display a copyright notice and the CDT model number.
3. If the CDT display screen is blank, drive the vehicle a short distance to activate the onboard computer.
4. If the vehicle will not operate, proceed to **Run/Tow Switch Test without the CDT Handset.**
5. If the CDT display screen begins to work after the vehicle has been driven, turn the key switch to the OFF position and proceed to step 6; otherwise, perform **Run/Tow Switch Test without the CDT Handset.**
6. With the CDT still connected to the vehicle, place the Run/Tow Switch in the TOW position and wait 90 seconds.
7. If the CDT display screen goes blank, the Run/Tow switch and connecting wires are operating correctly.
8. If the CDT display screen is still active after 90 seconds, the switch has failed closed. Replace the Run/Tow switch. **See Run/Tow Switch Removal on page 13-4.**

Run/Tow Switch Test without the CDT Handset

1. Set a multimeter to 200 volts DC. With the batteries connected, and the Run/Tow switch in either the TOW or RUN position, connect the black (–) probe to the negative post of battery no. 8 and connect red (+) probe (with insulation-piercing probe) on the pink wire close to the two-pin connector on the Run/Tow switch.
2. If the reading is 48 to 50 volts, proceed to Step 3. If the voltage reading is 0 volts, check wire continuity from the large post of the solenoid (red, 12-gauge wire (w80) attached), through sonic weld 12 (where it changes to a pink, 16-gauge wire (w50)), to the pink wire side of the Run/Tow switch two-pin connector.
3. Set a multimeter to 200 volts DC and with the batteries connected, connect the black (–) probe to the negative post of battery no. 8 and connect red (+) probe (with insulation-piercing probe) on the light green wire (1) close to the two-pin connector on the Run/Tow switch.
4. With the Run/Tow switch in the RUN position, the reading should be approximately 48 to 50 volts. With the switch in the TOW position, the reading should be approximately 0 volts.
5. If the two-pin connector and pink wire continuity readings are correct, replace the Run/Tow switch.

TEST PROCEDURE 4 – Fuses

See General Warnings on page 1-1.

⚠ WARNING

- Failure to use properly rated fuse can result in a fire hazard.

NOTE: These vehicles predominately use a combination of ATC-style and ATM-style blade fuses. A single AGC-style glass fuse is used for the charger interlock circuit.

This is a voltage test. It can be performed relatively easily on ATC-style and ATM-style fuses. A voltage test can be performed on the AGC-style glass fuse if insulation-piercing probes are used. Otherwise, the AGC-style will have to be removed to visually inspect or check using a continuity test.

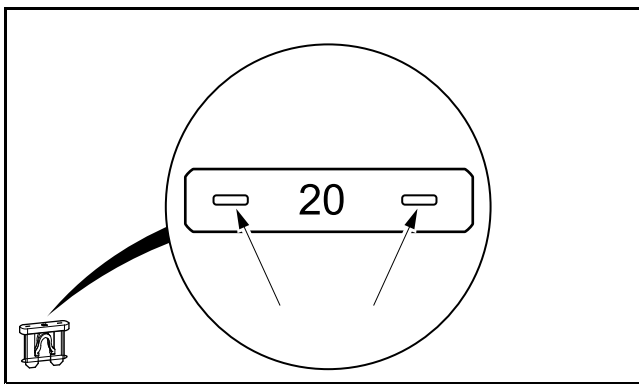

2976

Figure 12-8 Testing the Fuse

1. If necessary, see Testing Basics on page 12-14.
2. Access the fuses but do not remove them. Fuses are found at the following locations:
 - **On Controller Mounting Plate:** 15-amp fuse to DC/DC converter, 2-amp fuse to connected car device (Guardian/Visage V3 Circuit), and 15-amp fuse to electric powertrain
 - **Under Floorboard Near MCOR:** 20-amp fuse from DC/DC converter to accessories
 - **Under Front Cowl:** 15-amp fuse to cab, 10-amp fuse to brake lights, horn and turn signals, 7.5-amp fuse to headlights and taillights, 10-amp fuse to 12-volt power strip and power point
 - **On Main Harness Near Controller Mounting Plate:** 30-amp fuse for charger receptacle harness
 - **On Main Harness Forward of the 30-Amp Fuse:** 1-amp fuse for charger interlock circuit
3. **2-Amp and 15-Amp ATC Fuses On Controller Mounting Plate and 30-Amp ATC Charger Receptacle Fuse:** With the batteries connected and the Run/Tow switch in the RUN position:
 - 3.1. Probe the two, small metal contacts on the top of the fuse (**Figure 12-8, Page 12-19**).
 - 3.2. Each contact should show BPV.
 - 3.3. If only one side shows BPV, replace fuse.
 - 3.4. If neither side of fuse shows BPV, do the following:
 - Check BPV.
 - Check condition and connection of large red wires at solenoid.
 - Check sonic weld_8 in main wire harness.

- For one of the 15-amp ATC fuses, check Run/Tow switch to make sure it is in RUN position.
 - Check if 12 gauge red wire is coming off large post on solenoid.
4. **1-amp AGC Glass Fuse Only:** With the Run/Tow switch in the RUN position:
 - 4.1. Probe the wire on each side of the fuse with insulation-piercing probes.
 - 4.2. Each probe should show 42 to 46 volts.
 - 4.3. If only one side shows voltage, replace fuse.
 - 4.4. If neither side of fuse shows voltage, do the following:
 - Check Run/Tow switch to make sure it is in RUN position.
 - Check diode_1 in main wire harness.
 - Check 10k ohm in main wire harness.
 - Check 15-amp ATC fuse on controller mounting plate.
 5. **20-Amp ATC Fuse Near MCOR and ATM Fuses Under Front Cowl:** With the batteries connected, key switch ON and DC/DC converter operating:

NOTE: For these fuses only, connect the black probe of the meter to the 12 volt ground terminal block located under the front cowl.

- 5.1. Probe the two, small metal contacts on the top of the fuse (**Figure 12-8, Page 12-19**).
- 5.2. Each contact should show approximately 12.5 to 13.5 volts.
- 5.3. If only one side shows 12.5 to 13.5 volts, replace fuse.
- 5.4. If neither side of fuse shows 12.5 to 13.5 volts, do the following:
 - Check 15-amp ATC fuse on controller mounting plate that supplies power to DC/DC converter. If fuse is good, check converter.
 - **For ATM Fuses Under Front Cowl:** Check sonic weld_4 in main wire harness.
 - Check key switch.
 - Check lockout relay.
 - **For All Fuses Powered by the DC/DC Converter:** Check sonic weld_16 in main wire harness.

TEST PROCEDURE 5 – Circuit Breaker

See General Warnings on page 1-1.

1. Check the circuit breaker position:
 - 1.1. If the circuit breaker is in the tripped position, push the button in to close the circuit.
2. Turn the key switch to OFF.
3. Make sure that the Run/Tow switch is in the RUN position.
4. Set a multimeter on 200 volts DC. With the batteries connected, connect the negative (–) lead to battery no. 8 negative post. With an insulation-piercing probe, connect the positive (+) lead to the green wire on the back of the circuit breaker.
 - 4.1. If there is 48 volts, check the voltage at the tan wire.
 - 4.2. If there is no voltage, use the wiring diagram to find the broken wire between the green wire and SW 12.
5. Set a multimeter on 200 volts DC. With the batteries connected, connect the negative (–) lead to battery no. 8 negative post. With an insulation-piercing probe, connect the positive (+) lead to the tan wire on the back of the circuit breaker.
 - 5.1. If there is no voltage, replace the circuit breaker.

6. If there is 48 volts, do the following:
7. Make sure that the green and tan wires are securely connected to the circuit breaker.
8. Make sure that the 24 pin connector has no corrosion.
9. Make sure that the 24 pin connector is securely connected to the controller.
10. Make sure that the number 3 pin of the 24 pin connector is seated correctly into the 24 pin connector.
11. Number 3 pin voltage check:
 - 11.1. Set the Run/Tow switch to TOW.
 - 11.2. Disconnect the batteries.
 - 11.3. Disconnect the 24 pin connector from the controller.
 - 11.4. Connect the batteries. Do not connect the 24 pin connector to the controller.
 - 11.5. Set the Run/Tow switch to RUN.
 - 11.6. Check the voltage at the number 3 pin of the 24 pin connector.
12. If there is voltage at the number 3 pin:
 - 12.1. Replace the controller.

NOTE: Make sure the correct controller is used.

Early 2006 model year to 2013 model year (with onboard computer) and Villager 6 & 8: use controller model number 1520

Mid model year 2014 models without onboard computer (OBC) onboard charger (Delta Quiq): use controller model number 1520L

13. If there is no voltage at the number 3 pin:
 - 13.1. Check for voltage at the green wire on the circuit breaker switch.
 - 13.1.1. If there is 48 volts, there is a broken wire between the tan wire on the circuit breaker and the number 3 pin on the 24 pin connector. Use the wiring diagram to find the broken wire.
14. Set the Run/Tow switch to TOW.
15. Disconnect the batteries.
16. Connect the 24 pin connector to the controller.
17. Connect the batteries.
18. Set the Run/Tow switch to RUN.

TEST PROCEDURE 6 – Wire Harness Diodes

See General Warnings on page 1-1.

A diode is designed to conduct current in one direction only. Depending on the application, diodes are used in the vehicle to control electrical system logic, or to help protect relay and switch contacts from excessive arcing. **See following NOTE.**

NOTE: If a diode conducts current in both directions, the diode has failed closed. If a diode will not conduct current in either direction, the diode has failed open (**Figure 12-9, Page 12-22**).

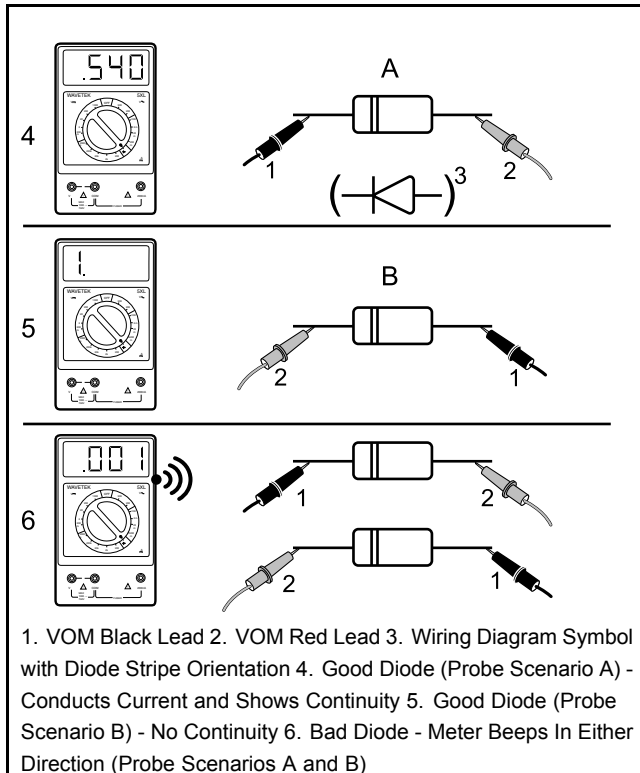

1127

Figure 12-9 Basic Diode Information

TEST PROCEDURE 7 – Key Switch and MCOR Limit Switch Circuit

See General Warnings on page 1-1.

NOTE: This is a voltage test.

The MCOR provides FOOT INPUT to the controller.

The key switch provides KEY INPUT to the controller.

Key Switch and MCOR Limit Switch Circuit Test with the CDT Handset

1. Place chocks at the front wheels and lift the rear of the vehicle with a chain hoist or floor jack. Position jack stands under the frame crossmember between the spring mount and side stringer, just forward of each rear wheel. **See WARNING “Lift only one end...” in General Warnings on page 1-1.**
2. Turn the key switch to the OFF position and place the Forward/Reverse switch in the NEUTRAL position.
3. Connect the CDT to the vehicle. **See Plugging the CDT into the Vehicle on page 11-2.**
4. Test the key switch.
 - 4.1. Access the Monitor menu, and select KEY INPUT by using the SCROLL DISPLAY buttons. The CDT should indicate OFF when the key switch is in the OFF position.
 - 4.2. While monitoring the CDT display screen, turn the key switch to the ON position. The CDT should indicate ON.
 - 4.3. If the CDT does not indicate that KEY INPUT is ON when the key switch is in the ON position, proceed to the following procedure, Key Switch and MCOR Limit Switch Circuit Test without the CDT Handset. If the key switch functions as described, proceed to the following step. **See following NOTE.**

NOTE: The key switch **MUST** function properly in order to test the MCOR limit switch with the CDT handset.

5. Test the MCOR limit switch.
 - 5.1. Select FOOT INPUT on the Monitor menu by using the SCROLL DISPLAY buttons on the CDT.
 - 5.2. The CDT should indicate that FOOT INPUT is OFF when the accelerator pedal is not pressed, regardless of the key switch position.
 - 5.3. With the key switch in the ON position, press the accelerator pedal. The CDT should indicate that FOOT INPUT is ON when the accelerator pedal is pressed.
6. If any reading is obtained that is not described in steps 4 and 5, perform the following steps:
 - 6.1. Check the pedal group for proper adjustment. **See Accelerator and Brake Pedal Group Section.**
 - 6.2. Check the wiring of the key switch and MCOR. **See Wiring Diagrams on page 12-4.**
 - 6.3. Check the continuity of the key switch wires and the MCOR limit switch wires.
7. If the problem was not found, proceed to the following procedure.

Key Switch and MCOR Limit Switch Circuit Test without the CDT Handset

1. If necessary, see Testing Basics on page 12-14.
2. Place chocks at the front wheels and lift the rear of the vehicle with a chain hoist or floor jack. Position jack stands under the frame rails just forward of each spring mount. **See WARNING “Lift only one end...” in General Warnings.**
3. Place the Run/Tow switch in the RUN position and the Forward/Reverse switch in the NEUTRAL position.
4. **Pin 1 Tan Wire:** Lift bed, remove access cover, access the controller. **See following NOTE.**

NOTE: The easiest way to test the key switch and MCOR Limit Switch is to check the pin 1 tan wire in the 24-pin connector. Pin 1 is the end of this circuit.

- 4.1. Locate and connect an insulation-piercing probe to the pin 1 tan wire in the 24-pin connector.
- 4.2. With the key switch in the OFF position and the accelerator pedal at rest, the tan wire should show zero (0) volts.
- 4.3. With the key switch in the ON position and the accelerator pedal pressed, the tan wire should show BPV which is KEY INPUT (ON position) to controller.
 - If it shows BPV, then the key switch and related wiring is functioning properly.
 - If not, first check the key switch.
5. **Key Switch:** Remove instrument panel to access the back of the key switch but do not disconnect wires. **See Instrument Panel Removal, Section 4, Page 4-10.**
 - 5.1. With the key switch in the OFF position:
 - The green wire should show BPV coming to the switch.
 - The blue wire should show zero (0) volts. If it shows BPV, the switch has failed CLOSED and must be replaced.
 - 5.2. With the key switch in the ON position:
 - The blue wire should show BPV passing through the key switch to the MCOR. If it does not show BPV, the switch has failed OPEN and must be replaced.
6. **MCOR Limit Switch (FOOT INPUT):** Access the MCOR from under the vehicle passenger side.
 - 6.1. With the key switch in the ON position:
 - With an insulation-piercing probe, check voltage of the blue wire in the MCOR 2-pin connector. It should show BPV coming to the MCOR. If not, check wiring.
 - With an insulation-piercing probe, check voltage of the green wire in the MCOR 2-pin connector. It should show zero (0) volts with the accelerator pedal at rest. Press the accelerator pedal and the green wire should show BPV passing through the MCOR to the controller for FOOT INPUT. From the MCOR, the blue wire supplies voltage (BPV) to pin 8. If not, replace MCOR. **See MCOR Removal on page 13-6.**

TEST PROCEDURE 8 – Forward/Reverse Rocker Switch

See General Warnings on page 1-1.

NOTE: This is a voltage test.

The Forward/Reverse Switch provides FORWARD INPUT and REVERSE INPUT to the controller.

If the controller sees both FORWARD INPUT and REVERSE INPUT at the same time, the reverse buzzer will sound in all FNR positions and the vehicle will not operate in either direction. Common causes of this include corrosion across the contacts inside the switch, water inside the switch, or a switch that has failed CLOSED.

Forward/Reverse Rocker Switch Test with the CDT Handset

1. Turn the key switch to the OFF position and place the Forward/Reverse switch in the NEUTRAL position.
2. Connect the CDT to the vehicle. **See Plugging the CDT into the Vehicle, Section 11, Page 11-2.**
3. Test FORWARD INPUT.
 - 3.1. Access the Monitor menu and select FORWARD INPUT by using the SCROLL DISPLAY buttons. The CDT should indicate OFF when the Forward/Reverse switch is in the NEUTRAL or REVERSE position.
 - 3.2. Place the Forward/Reverse switch in the FORWARD position. The CDT should indicate that FORWARD INPUT is ON. If the CDT indicates any other reading, check vehicle wiring. **See Wiring Diagrams beginning on page 12-4.** Also check the 24-pin connector at the speed controller. **See 24-Pin Connector on page 12-33.**
4. Test REVERSE INPUT.

- 4.1. Access the Monitor menu and select REVERSE INPUT by using the SCROLL DISPLAY buttons. The CDT should indicate OFF when the Forward/Reverse switch is in the NEUTRAL or FORWARD position.
- 4.2. Place the Forward/Reverse switch in the REVERSE position. The CDT should indicate that REVERSE INPUT is ON. If the CDT indicates any other reading, check vehicle wiring. **See Wiring Diagrams on page 12-4.** Also check the 24-pin connector at the speed controller. **See 24-Pin Connector on page 12-33.**
5. If the CDT displays readings other than those described above and the wiring is found to be correct, proceed to the following procedure.

Forward/Reverse Rocker Switch Test without the CDT Handset

1. If necessary, see Testing Basics on page 12-14.
2. Place the Run/Tow switch in the RUN position and the Forward/Reverse switch in the NEUTRAL position.
3. Remove Forward/Reverse switch from its housing by carefully prying up each side with a small, flat-tip screwdriver.
4. Back-probe the following three wires connected to the Forward/Reverse switch in each position:
 - 4.1. **Orange Wire**
 - The orange wire provides power to the switch and should show BPV coming to the switch in all three positions.

If the orange wire does not show BPV, check the 15-amp fuse, Run/Tow switch, red-to-pink wire spade terminal connection and related wiring.
 - 4.2. **Brown Wire**
 - The brown wire should show BPV in FORWARD.
 - The brown wire should show zero (0) volts in NEUTRAL and REVERSE

If the brown wire shows voltage in NEUTRAL, the switch may have corrosion across the contacts or the switch has failed CLOSED and must be replaced. **See Forward/Reverse Rocker Switch Removal on page 13-3.**

If the brown wire does not show BPV in FORWARD, the switch may have corrosion on the contact or the switch has failed OPEN and must be replaced. **See Forward/Reverse Rocker Switch Removal on page 13-3.**
 - 4.3. **Red/Green Wire**
 - The red/green wire should show BPV in REVERSE.
 - The red/green wire should show zero (0) volts in NEUTRAL and FORWARD.

If the red/green wire shows voltage in NEUTRAL, the switch may have corrosion across the contacts or the switch has failed CLOSED and must be replaced. **See Forward/Reverse Rocker Switch Removal on page 13-3.**

If the red/green wire does not show BPV in REVERSE, the switch may have corrosion on the contact or the switch has failed OPEN and must be replaced. **See Forward/Reverse Rocker Switch Removal on page 13-3.**
5. When installing the Forward/Reverse switch into its housing, orient the three wire terminals towards the front of the vehicle (i.e. biased closer to the front of the switch housing and farther from the rear body).

TEST PROCEDURE 9 – Solenoid Activating Coil

See General Warnings on page 1-1.

NOTE: This is a resistance test.

1. If necessary, see Testing Basics on page 12-14.

2. Disconnect the batteries and discharge the controller. **See Disconnecting the Batteries – Electric Vehicles on page 1-4.**
3. Access the solenoid by removing the electronics module cover. **See Removing the Speed Controller Cover on page 13-7.**
4. Remove the two small wire terminals from the solenoid.
5. Place red (+) probe of the multimeter on the positive (+) solenoid terminal. Place the black (–) probe on the other small solenoid terminal.
 - A reading of 180 to 190 ohms should be obtained (**Figure 12-10, Page 12-26**). If not, replace the solenoid.

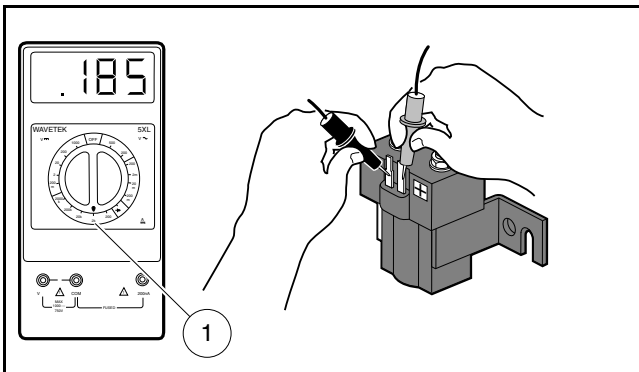

2500-20000-10283

Figure 12-10 Activating Coil Test – Service Replacement Solenoid

TEST PROCEDURE 10 – Solenoid Contacts

See General Warnings on page 1-1.

NOTE: Unlike other controllers used by Club Car, the pre-charge resistor is internal to the IQ Plus controller.

1. Place chocks at the front wheels and lift the rear of the vehicle with a chain hoist or floor jack. Position jack stands under the frame crossmember between the spring mount and side stringer, just forward of each rear wheel. **See WARNING “Lift only one end...” in General Warnings on page 1-1.**
2. Turn the key switch to the ON position and place the Forward/Reverse switch in the FORWARD position.
3. Set a multimeter to 200 volts. Place the black (–) probe on the battery no. 8 negative post and place the red (+) probe on the large post with the 6-gauge yellow wire.
4. With the pedal up, the reading should be 9.5 to 10.5 volts. If the voltage is higher, let the car sit for 5 to 10 minutes to allow the capacitors to discharge to 9.5 to 10.5 volts.
5. Press the accelerator pedal. The voltage should read 48 to 50 volts with the pedal pressed. If the voltage does not increase or goes to 0 volts with the pedal pressed, replace the solenoid.

TEST PROCEDURE 11 – Charger Interlock

See General Warnings on page 1-1.

Controller Interlock Function Test with the CDT Handset

1. If necessary, see **See Testing Basics, Section 12, Page 12-14.**
2. Connect the CDT to the vehicle.
3. Access the Monitor menu and select CHARGER INHIBIT by using the SCROLL DISPLAY buttons. The CDT should indicate OFF.

4. Insert the onboard charger AC plug into an AC outlet.
5. In a few seconds, the CDT should indicate ON and the vehicle can no longer be driven. If not, check the KEY, FORWARD, REVERSE and FOOT INPUTS to the controller.
 - If the CDT does not indicate ON, check circuit wiring and DC plug connection. See the following procedure **Testing the Interlock Circuit**.
 - If the CDT does indicate ON, but the vehicle can still be driven, replace the controller. **See Speed Controller Removal, Section 13, Page 13-9.**

Testing the Interlock Circuit

The charger interlock circuit consists of a 48 V power source through the RUN/TOW switch, sonic welds, a lockout relay, two diodes, a 15-amp fuse, and a 10k ohm resistor. **See following NOTE.** Use the following procedure to test the charger interlock circuit:

NOTE: The following steps involve testing voltage and resistance.

1. With batteries connected, place the Run/Tow switch in the RUN position.
2. Remove electronics module cover.
3. **Check 15-amp fuse:** Check the 15-amp fuse located in the electrical component box. It is the fuse that has a pink wire and a light green wire connected to it. **See Test Procedure 4 – Fuses on page 12-19.**
4. **Check power:** Using a multimeter set to 200 volts DC, place red (+) probe (with insulation-piercing probe) on the light blue wire (pin 2 of the 24-pin connector) and black (–) probe on B- terminal of controller. The reading should be approximately 42 to 46 volts. If the reading is not approximately 42 to 46 volts, proceed to check the 10k ohm resistor. If the reading is approximately 42 to 46 volts, check continuity of circuit wires.
5. **Check 10k ohm resistor:** Set multimeter to 20k ohms. Remove the 15-amp fuse. With the red (+) probe (with insulation-piercing probe) still on the light blue wire (pin 2 of the 24-pin connector), place the black (–) probe to the pink wire terminal in the 15-amp fuse holder. The reading should be approximately 10.0k ohms. If the reading is not approximately 10.0k ohms, replace the resistor or main wire harness .
6. **Check 1-amp fuse:** Remove and check the 1-amp fuse from the yellow fuse holder in onboard charger harness lead.
7. **Check D_1 diode:** Set multimeter to Diode test and check diode 1 (D_1) near onboard charger harness lead. **See Wire Harness Diodes on page 12-22.** Probe between the light blue wire (pin 2 of the 24-pin connector) at the controller and the light blue wire terminal (pin 4 of the 8-pin connector) of the onboard charger.
8. When finished, install 15-amp fuse.

TEST PROCEDURE 12 – MCOR Voltage

See General Warnings on page 1-1.

NOTE: This is a voltage test.

The accelerator position, which is proportional to the MCOR voltage, can be displayed with the CDT handset. If an CDT handset is not available, proceed to **MCOR Voltage Test without the CDT Handset**.

The following are potential MCOR symptoms:

- Vehicle will not drive due to no FOOT INPUT to the controller.
- Vehicle will not reach top speed because MCOR does not reach 100% throttle position.
- Vehicle does not maintain speed nor will it accelerate due to MCOR having a “dead-spot” in its pedal travel.
- The voltage signal from the MCOR randomly or sporadically fluctuates with pedal at rest, during pedal travel and with pedal fully pressed.

MCOR Voltage Test with the CDT Handset

1. Place chocks at the front wheels and lift the rear of the vehicle with a chain hoist or floor jack. Position jack stands under the frame crossmember between the spring mount and side stringer, just forward of each rear wheel. **See WARNING “Lift only one end...” in General Warnings on page 1-1. See also following WARNING.**

⚠ WARNING

- **The key switch should be placed in the OFF position and left in the OFF position for the duration of this test.**
2. Connect the CDT to the vehicle. **See Plugging the CDT into the Vehicle on page 11-2.**
 3. Access the Monitor menu and select THROTTLE % by using the SCROLL DISPLAY buttons.
 4. The CDT should indicate 0% with the pedal not pressed. While monitoring the CDT display screen, slowly press the accelerator pedal. As the pedal is pressed, the CDT should indicate a steady, incremental rise from 0% (pedal not pressed) to 100% (pedal fully pressed). **See following NOTE.**

NOTE: *Observe closely to see if throttle input percentage randomly or sporadically fluctuates with pedal at rest, during pedal travel and with pedal fully pressed. If it fluctuates or does not rise to 100%, check the drive bar for wear. If drive bar is not worn, replace MCOR.*

5. If the MCOR passes the previous test, press and hold the accelerator pedal to the floor. By hand, gently move the pedal from side to side and see if the throttle input percentage fluctuates from 100%. If it fluctuates, check the drive bar for wear. If drive bar is not worn, replace MCOR.
6. If throttle input percentage never reaches 100% in the previous steps, check the drive bar for wear. If drive bar is not worn, replace MCOR.

MCOR Voltage Test without the CDT Handset

1. Place chocks at the front wheels and lift the rear of the vehicle with a chain hoist or floor jack. Position jack stands under the frame rails just forward of each spring mount. **See WARNING “Lift only one end...” in General Warnings. See also following WARNING.**

⚠ WARNING

- **The key switch should be placed in the OFF position and left in the OFF position for the duration of this test.**
2. With the batteries connected, place Run/Tow switch in RUN. Using a multimeter set to 200 volts DC, place red (+) probe on battery no. 1 positive post and place black (–) probe (with insulation-piercing probe) on the purple/white wire at a point close to the three-pin connector at the MCOR. The reading should be approximately 48 to 50 volts (full battery voltage).
 3. If reading is zero volts, check the purple/white wire continuity from the three-pin connector at the MCOR to the 16-pin connector at the speed controller. Check terminal positions in three-pin connector at the MCOR and the 16-pin connector. If all of the continuity readings are correct and the connectors are wired correctly, replace the speed controller.
 4. With multimeter set to 20 volts DC, place the black (–) probe on battery no. 6 (6 x 8 volt battery set) negative post and the red (+) probe (with insulation-piercing probe) on the white wire at a point close to the three-pin connector at the MCOR. The reading should be approximately 4.65 volts.
 5. If reading is zero volts, check the white wire continuity from the three-pin connector at the MCOR to the 16-pin connector at the speed controller. Check terminal positions in three-pin connector at the MCOR and the 16-pin connector. If all of the continuity readings are correct and the connectors are wired correctly, replace the speed controller.
 6. With multimeter set to 20 volts DC, place the black (–) probe on battery no. 6 (6 x 8 volt battery set) negative post and the red (+) probe (with insulation-piercing probe) on the yellow wire at a point close to three-pin connector

at the MCOR. The reading should be zero (0) volts with the pedal up. Slowly press the accelerator pedal and note the readings on the multimeter. As the pedal is pressed, the reading should increase until it reaches approximately 4.65 volts when the pedal is fully pressed.

7. If reading does not increase as the pedal is pressed, check the drive bar for wear. If drive bar is not worn, replace MCOR. **See following NOTE.**

NOTE: Observe closely to see if voltage randomly or sporadically fluctuates with pedal at rest, during pedal travel and with pedal fully pressed. If it fluctuates, the MCOR is defective and must be replaced.

TEST PROCEDURE 13 – Motor Speed Sensor

See General Warnings on page 1-1.

Motor Speed Sensor Test without any Tool

CAUTION

- Perform the following procedure only on a level surface. To avoid injury or property damage, ensure that the path of the vehicle is clear before pushing vehicle.

1. Place the Forward/Reverse switch in the REVERSE position to verify reverse buzzer is functioning properly. If not, repair or replace the buzzer.
2. With Run/Tow switch in the RUN position, turn the key switch to the OFF position and place the Forward/Reverse switch in the NEUTRAL position.
3. Slowly push the vehicle a short distance (about 3 feet (1 meter)). The reverse buzzer should sound and motor braking should engage while the vehicle is rolling.
4. If the reverse buzzer does not sound and motor braking does not engage while the vehicle is rolling, replace the Motor Speed Sensor.

Motor Speed Sensor Test with the CDT Handset

CAUTION

- Perform the following procedure only on a level surface. To avoid injury or property damage, ensure that the path of the vehicle is clear before pushing vehicle.

1. Turn the key switch to the OFF position and place the Forward/Reverse switch in the NEUTRAL position.
2. Connect the CDT to the vehicle. **See Plugging the CDT into the Vehicle, Section 11, Page 11-2.**
3. Access the Monitor menu and select SPEED PULSES by using the SCROLL DISPLAY buttons. The CDT should indicate OFF when the vehicle is at rest.
4. While monitoring the CDT display screen, slowly push the vehicle a short distance (about 3 feet (1 meter)). The CDT should indicate ON for speed sensor pulses while the wheels are in motion.
5. If the CDT does not indicate ON while the wheels are in motion, proceed to the following procedure.

Motor Speed Sensor Test without the CDT Handset

NOTE: The Motor Speed Sensor uses the 6-pin connector at controller.
Pins 4, 5, and 6 are the outputs and inputs to the controller and speed sensor.
Pin 4: Black/White Wire — Ground
Pin 5: Light Green Wire — Input to controller (0 to 5 volts)
Pin 6: Red Wire — Output from controller (15 volts to sensor)

1. Turn the key switch to the OFF position and place the Forward/Reverse switch in the NEUTRAL position.
2. With batteries connected, disconnect the three-pin connector at the motor speed sensor.
3. Check voltage at black/white wire:
 - 3.1. Set a multimeter to 200 volts DC. Place the red (+) probe on the battery no. 1 positive post and place the black (-) probe on the black/white wire terminal socket in the three-pin connector. The voltage reading should be 48 to 50 volts (full battery voltage).
 - 3.2. If the reading is zero volts, check the continuity of the black/white wire from the 24-pin connector at the speed controller to the three-pin connector at the motor speed sensor. If the continuity is correct, replace the speed controller.

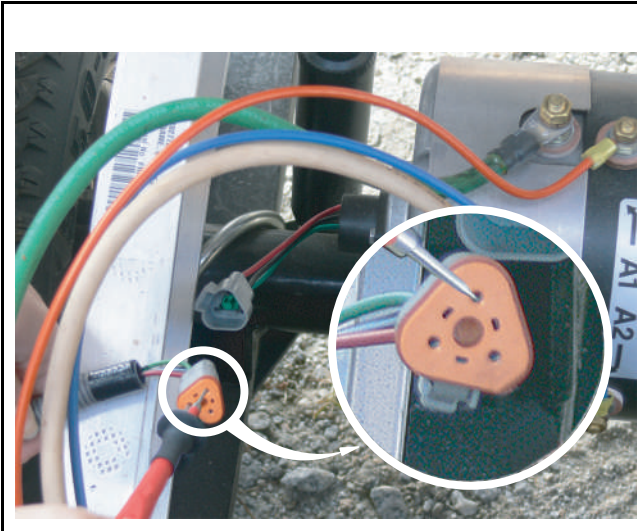

Figure 12-11 Test 13: Speed Sensor Black/White Wire

4. Check voltage at the red motor speed sensor wire:
 - 4.1. With Run/Tow switch in the RUN position and using a multimeter set to 20 volts DC, place the black (-) probe on the battery no. 8 negative post and place red (+) probe on red wire terminal socket in three-pin connector. The voltage reading should be approximately 15 to 16 volts.
 - 4.2. If the voltage reading is zero volts, check the continuity of the red wire from the 24-pin connector at the speed controller to the three-pin connector at the motor speed sensor. If the wire continuity is correct, replace the speed controller.
 - 4.3. If the reading is below 14 volts, replace the speed controller.
 - 4.4. If the voltage reading is correct, proceed to the following step.

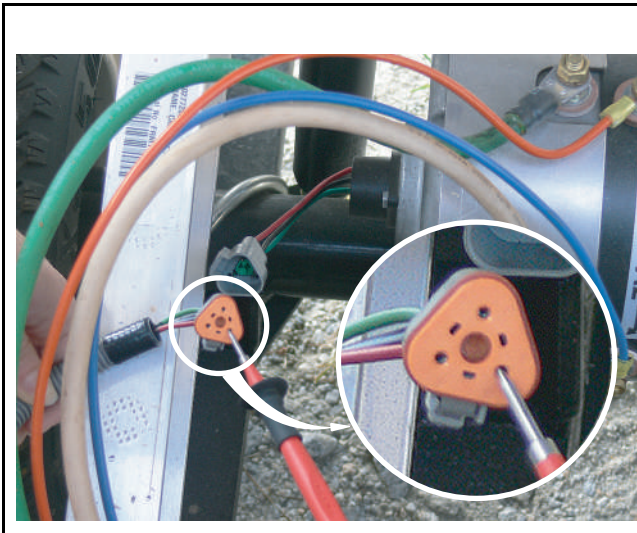

Figure 12-12 Test 13: Speed Sensor Red Wire

5. Check voltage at the light green wire:
 - 5.1. Set a multimeter to 20 volts DC. Place the black (–) probe on the battery no. 8 negative post and place the red (+) probe on the light green wire female terminal in the three-pin connector at the motor speed sensor. The voltage reading should be from 4.60 to 5.00 volts.
 - 5.2. If the voltage is zero volts, check the continuity of the light green wire from the 24-pin connector at the speed controller to the three-pin connector at the motor speed sensor. If the continuity is correct, replace the speed controller.
 - 5.3. If reading is below 3.50 volts, check the continuity of the wires and plug and replace the speed controller if necessary.

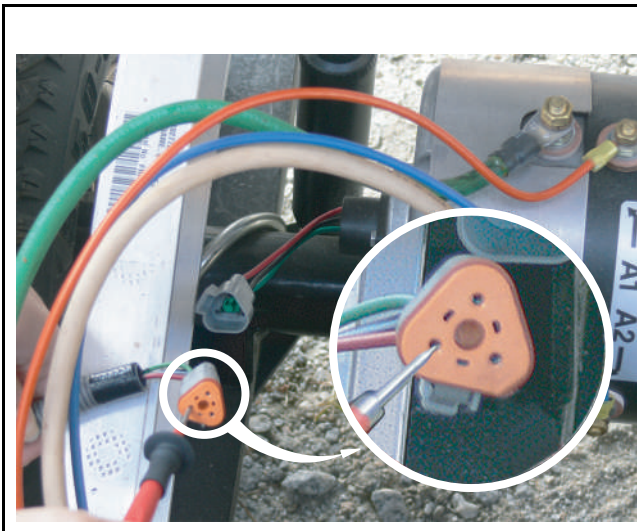

Figure 12-13 Test 13: Speed Sensor Light Green Wire

6. Reconnect the three-pin connector at the motor speed sensor. Using a multimeter set to 20 volts DC, place the black (–) probe on the battery no. 8 negative post and place the red (+) probe (with insulation-piercing probe) on the green wire between the three-pin connector and the motor speed sensor.

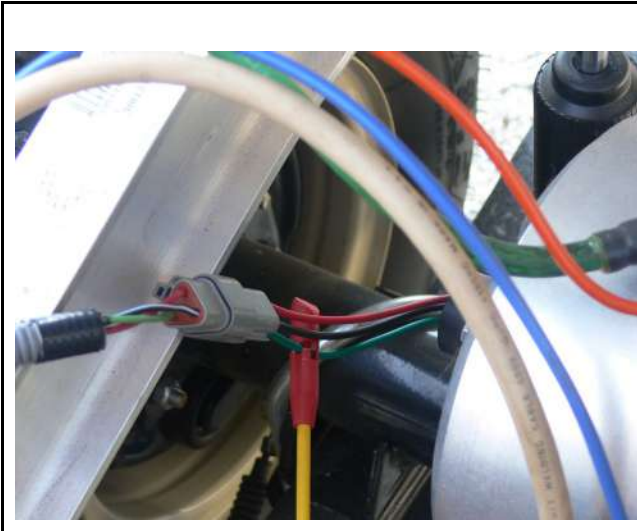

Figure 12-14 Test 13: Speed Sensor Green Wire

- 6.1. Raise one rear wheel off ground. Slowly turn the rear wheel to rotate the motor armature. As the armature rotates, the voltage reading should alternate from zero to approximately 4.85 volts. The voltage reading will fluctuate from zero to 4.85 volts and back to zero four times for each revolution of the motor armature. **See following NOTE.**

NOTE: The voltage reading of 4.85 is an approximate reading. The actual reading may vary from 4.50 to 5.00 volts.

- 6.2. Replace the speed sensor if
- there is no voltage reading.
 - the voltage reading is not above 3.50.
 - the voltage reading does not fluctuate as the motor is turned.

TEST PROCEDURE 14 – A1 and A2 Motor Voltage

See General Warnings on page 1-1.

1. Place chocks at the front wheels and lift the rear of the vehicle with a chain hoist or floor jack. Position jack stands under the frame crossmember between the spring mount and side stringer, just forward of each rear wheel. **See WARNING “Lift only one end...” in General Warnings on page 1-1. See also following WARNING.**

⚠ WARNING

- **Keep people and equipment clear from rotating rear wheels. Do not allow persons under the car. Contact with rotating rear wheels could result in serious personal injury.**
2. With the batteries connected and using a multimeter set to 200 volts DC, place the black (–) probe on the A2 (1) motor terminal (white wire) and connect the red (+) probe to the A1 (2) motor terminal (green wire) (**Figure 12-15, Page 12-33**).
 3. With Run/Tow switch in the RUN position, place the Forward/Reverse switch in the FORWARD position, turn key switch to the ON position and slowly press accelerator pedal.
 4. As the accelerator pedal is pressed, the voltage reading should increase from approximately 5 volts RMS when the MCOR limit switch closes, to approximately 32 to 37 volts RMS with the accelerator pedal fully pressed. **See following NOTE.**

NOTE: Voltage can vary depending on controller speed setting as well as which zone a Guardian equipped vehicle is located.

Example: Speed setting 1 may only read 30 volts.

- 4.1. If there is no voltage reading or if there is no increase in voltage as the pedal is pressed, check the MCOR. **See MCOR Voltage on page 12-27.** Also check the continuity of the large posts of the solenoid. **See Solenoid Contacts on page 12-26.**
- 4.2. Disconnect the batteries and discharge the controller. **See Disconnecting the Batteries – Electric Vehicles, Section 1, Page 1-4.**
- 4.3. Check continuity on A1 and A2 motor terminal posts and continuity of the F1 and F2 motor terminal posts. Also, check continuity of all motor wires. **See Motor Component Testing and Inspection, Section 16, Page 16-7.**
- 4.4. Connect the batteries. **See Connecting the Batteries – Electric Vehicles, Section 1, Page 1-4.**

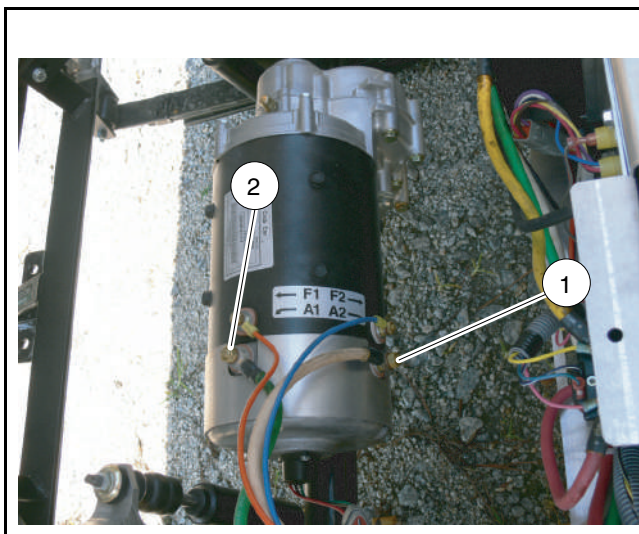

Figure 12-15 Test A1 and A2 Motor Voltage

TEST PROCEDURE 15 – 24-Pin Connector

See General Warnings on page 1-1.

1. Disconnect the batteries and discharge the controller. **See Disconnecting the Batteries – Electric Vehicles, Section 1, Page 1-4.**
2. Disconnect the 24-pin connector from the speed controller. Inspect terminal ends inside plug to ensure they are in position and seated in plug housing. If any terminals look like they are not pushed all the way into the connector, gently push the terminals until they are firmly seated in the 24-pin connector. After each terminal has been pushed into the housing, gently pull on the wire to ensure it is locked into place.
3. Check wires in the plug to make sure none are broken at the terminal pin crimp. Repair or replace as required.
4. Check the wire colors of each wire and make sure that the colors for each pin position match the wire colors in the wiring diagram. **See Wiring Diagrams beginning on page 12-4.**
5. When connecting the 24-pin connector to the controller, push plug into controller receptacle with enough force to lock plug into place. An audible click will be heard when plug is properly seated to the controller.

A procedure is provided for testing each of the wires in the 24-pin connector. Refer to the following chart for the appropriate procedure for each pin in the 24-pin connector.

If the results of any of the referenced procedures are different from those described in the procedure, check the continuity of the wires in the wire harness and test the connected components with the appropriate test procedures. (See **Index of Test Procedures on page 12-14**).

SPEED CONTROLLER 24-PIN CONNECTOR WIRE	TEST PROCEDURE
Pin 1 – Tan (18-gauge)	KEY INPUT
Pin 2 – Light Blue (18-gauge)	Test Procedure 11 – Charger Interlock on page 12-26
Pin 3 – Orange (18-gauge)	
Pin 4 – Gray (18-gauge)	Test Continuity of wire
Pin 5 – Open (no wire)	
Pin 6 – Open (no wire)	
Pin 7 – Open (no wire)	
Pin 8 – Green (18-gauge)	FOOT INPUT
Pin 9 – Pink (18-gauge)	Test continuity of wire
Pin 10 – Brown (18-gauge)	
Pin 11 – Red/Green (18-gauge)	
Pin 12 – Open (no wire)	
Pin 13 – White (18-gauge)	
Pin 14 – Purple/White (18-gauge)	Test continuity of each wire and perform
Pin 15 – Yellow (18-gauge)	
Pin 16 – Open (no wire)	
Pin 17 – Blue/White (18-gauge)	
Pin 18 – Open (no wire)	
Pin 19 – Orange/White (18-gauge)	
Pin 20 – Purple (18-gauge)	
Pin 21 – White/Black (18-gauge) Supplies approximately 13 volts to the Guardian/Visage unit.	CONNECTED CAR OUTPUT Approximately 13 volts measured between pin 1 and B- terminal on controller (Key switch either ON or OFF)
Pin 22 – Blue/Yellow (18-gauge) Supplies a positive (+), controlled current source to power the charge indicator light on the instrument panel.	CHARGE INDICATOR LIGHT OUTPUT Start a charging session. After a few seconds, light should flash. Can also be seen under LED Driver in the Monitor menu of the CDT.
Pin 23 – Green/White (18-gauge)	
Pin 24 – Open (no wire)	

Pins 13, 14, and 15

See **General Warnings on page 1-1**.

Pins 13, 14, and 15 in the 24-pin connector provide a connection point from the MCOR potentiometer to the speed controller.

1. Disconnect the batteries and discharge the controller. **See Disconnecting the Batteries – Electric Vehicles, Section 1, Page 1-4.**
2. Place chocks at the front wheels and lift the rear of the vehicle with a chain hoist or floor jack. Position jack stands under the frame crossmember between the spring mount and side stringer, just forward of each rear wheel. **See WARNING “Lift only one end...” in General Warnings on page 1-1.**
3. Disconnect the 24-pin connector at the speed controller.
4. Set a multimeter to 20k ohms. Insert the red (+) probe of the multimeter into pin 15 (yellow wire) of the 24-pin connector. **See following CAUTION.** Insert the black (–) probe into pin 14 (purple/white wire) of the 24-pin connector (**Figure 12-16, Page 12-35**).

CAUTION

- Do not fully insert probes into the 24-pin plug. Doing so can result in a poor connection.

5. With the accelerator pedal fully up (not pressed), the multimeter should read approximately 1k ohms.
6. Slowly press the accelerator pedal while monitoring the multimeter. The resistance should rise as the pedal is pressed. When the pedal is all the way to the floor, the multimeter should indicate between 5.67k ohms and 7.43k ohms.
7. Set a multimeter to 20k ohms. Insert the red (+) probe of the multimeter into pin 15 (yellow wire) at the 24-pin connector. Connect the black (–) probe into pin 13 (white wire). **See previous CAUTION.**
8. With the accelerator pedal fully up (not pressed), the multimeter should indicate between 5.67k ohms and 7.43k ohms.
9. Slowly press the accelerator pedal while monitoring the multimeter. The resistance should drop as the pedal is pressed. When the pedal is all the way to the floor, the multimeter should indicate approximately 1k ohms.
10. If any other reading is observed, check the continuity of the wires in the wire harness.
11. Connect the batteries. **See Connecting the Batteries – Electric Vehicles, Section 1, Page 1-4.**

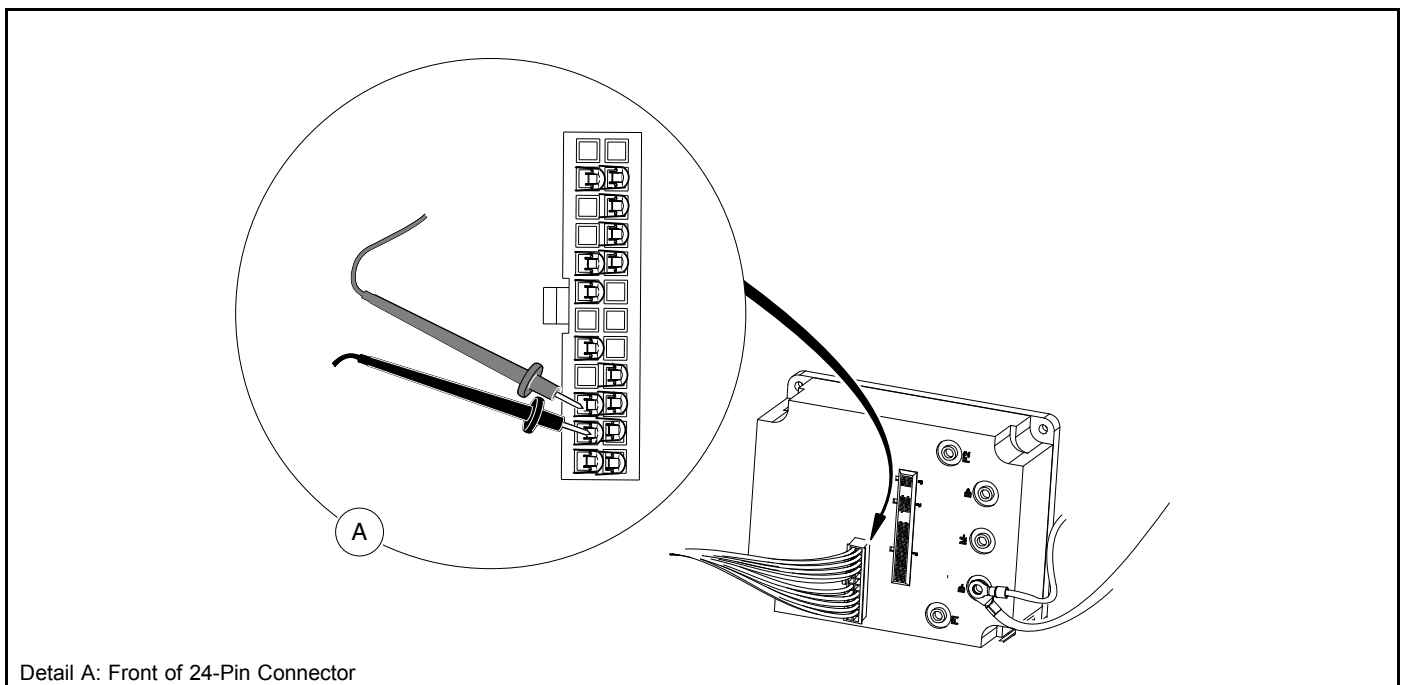

Figure 12-16 Test: Pins 14 and 15 (Purple/White and Yellow wires)

Pin 8

See General Warnings on page 1-1.

Pin 8 in the 24-pin connector provides a connection point for the MCOR limit switch to the speed controller.

1. Disconnect the batteries and discharge the controller. **See Disconnecting the Batteries – Electric Vehicles, Section 1, Page 1-4.**
2. Place chocks at the front wheels and lift the rear of the vehicle with a chain hoist or floor jack. Position jack stands under the frame crossmember between the spring mount and side stringer, just forward of each rear wheel. **See WARNING “Lift only one end...” in General Warnings on page 1-1.**
3. Disconnect the 24-pin connector at the speed controller.
4. Place the Run/Tow switch in the TOW position and connect the battery cables, positive (+) cable first. **See Connecting the Batteries – Electric Vehicles, Section 1, Page 1-4.**
5. Set a multimeter to 200 volts DC, insert the red (+) probe of the multimeter into pin 8 (green wire) of the 24-pin connector. **See following CAUTION.** Connect the black (–) probe to the B– terminal of the speed controller or negative (–) post of battery no. 8 (**Figure 12-17, Page 12-36**).

CAUTION

- Do not fully insert probes into the 24-pin plug. Doing so can result in a poor connection.

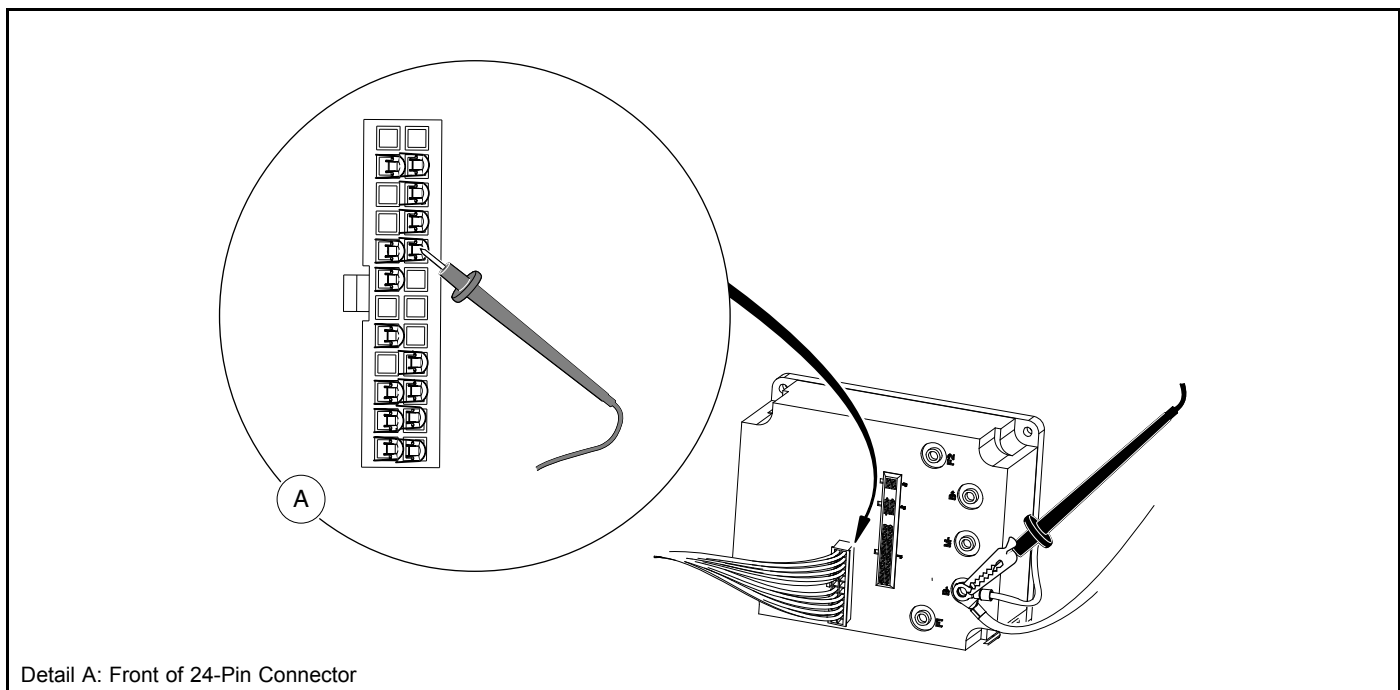

Figure 12-17 Test: Pin 8 (Green Wire)

6. Place the Run/Tow switch in the RUN position and key switch in the ON position.
7. The multimeter should indicate zero volts DC at this time.
8. The multimeter should indicate full battery voltage (approximately 48 volts) when the accelerator pedal is pressed.
9. While observing the multimeter, release the accelerator pedal.
10. The multimeter should indicate zero volts when the accelerator pedal is not pressed.
11. If any other reading is obtained, check the following items:
 - Continuity of the wires in the wire harness.

- Run/Tow switch for proper operation. **See Run/Tow Switch on page 12-18.**
- Key switch and MCOR limit switch for proper operation. **See Key Switch and MCOR Limit Switch Circuit on page 12-23.**
- Ensure that the pedal group is adjusted correctly. **See Accelerator and Brake Pedal Group Section.**

Pin 19

See General Warnings on page 1-1.

Pin 19 in the 24-pin connector provides a connection point for the reverse buzzer to the speed controller.

1. Disconnect the batteries and discharge the controller. **See Disconnecting the Batteries – Electric Vehicles, Section 1, Page 1-4.**
2. Place chocks at the front wheels and lift the rear of the vehicle with a chain hoist or floor jack. Position jack stands under the frame crossmember between the spring mount and side stringer, just forward of each rear wheel. **See WARNING “Lift only one end...” in General Warnings on page 1-1.**
3. Disconnect the 24-pin connector at the speed controller.
4. Place a jumper wire with an alligator clip between the B– terminal of the speed controller (use alligator clip for this connection) and pin 19 (orange/white wire) of the 24-pin connector (**Figure 12-18, Page 12-38**). **See following CAUTION.**

CAUTION

- **Do not fully insert probes into the 24-pin plug. Doing so can result in a poor connection.**

5. Place the Run/Tow switch in the TOW position and connect the battery cables, positive (+) cable first. **See Connecting the Batteries – Electric Vehicles, Section 1, Page 1-4.**
6. Place the Run/Tow switch in the RUN position.
7. The reverse buzzer should sound when the Run/Tow switch is in the RUN position.
8. If any other activity is observed, check the following items:
 - Continuity of the wires in the wire harness
 - Reverse buzzer for proper operation. **See Reverse Buzzer on page 12-42.**
 - Run/Tow switch for proper operation. **See Run/Tow Switch on page 12-18.**

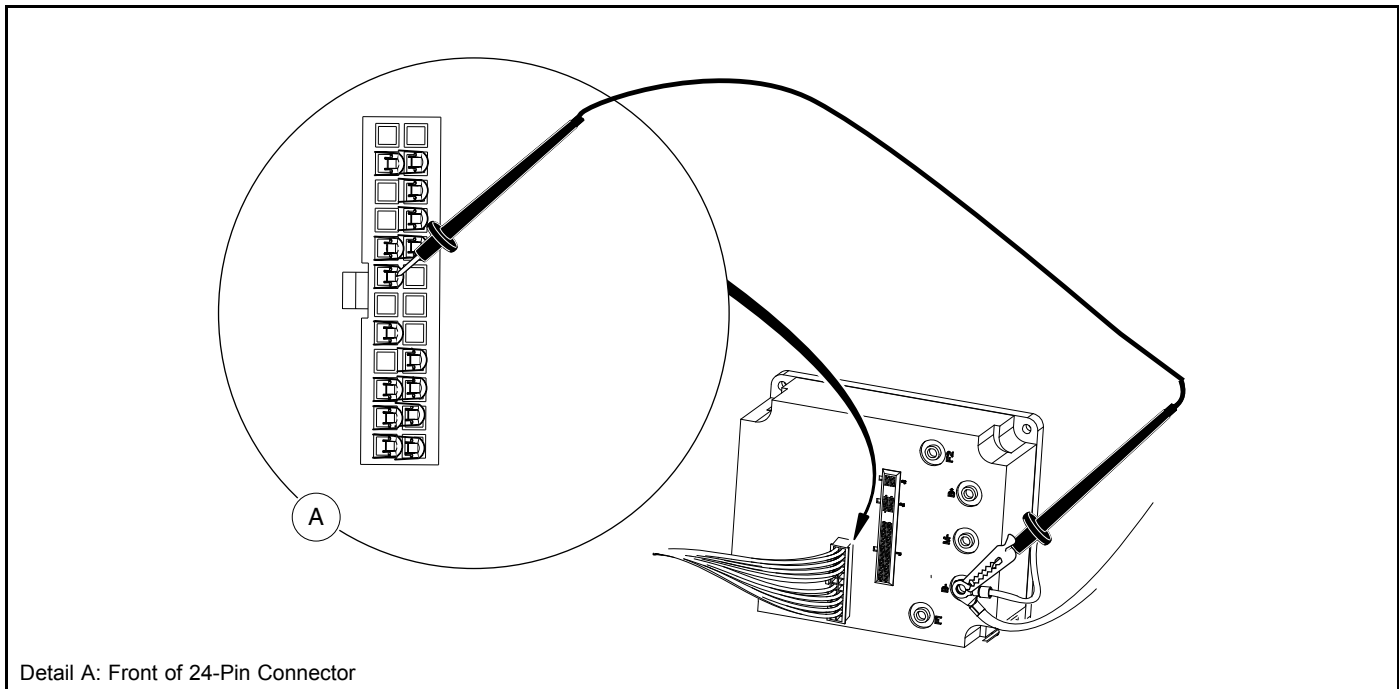

Detail A: Front of 24-Pin Connector

Figure 12-18 Test: Pin 19 (Orange/White Wire)

Pins 10 and 11

See General Warnings on page 1-1.

Pins 10 and 11 in the 24-pin connector provide a connection point for the Forward/Reverse rocker switch to the speed controller. The switch provides a +48 volt signal to the speed controller through pin 10 when the Forward/Reverse switch is in the FORWARD position and provides a +48 volt signal on pin 11 when the Forward/Reverse switch is in the REVERSE position.

1. Disconnect the batteries and discharge the controller. **See Disconnecting the Batteries – Electric Vehicles, Section 1, Page 1-4.**
2. Place chocks at the front wheels and lift the rear of the vehicle with a chain hoist or floor jack. Position jack stands under the frame crossmember between the spring mount and side stringer, just forward of each rear wheel. **See WARNING “Lift only one end...” in General Warnings on page 1-1.**
3. Disconnect the 24-pin connector at the speed controller.
4. Set a multimeter to 200 volts DC, insert the red (+) probe of the multimeter into pin 10 (brown wire) of the 24-pin connector. **See following CAUTION.** Using an alligator clip, connect the black (–) probe to the B– terminal of the speed controller (**Figure 12-19, Page 12-39**).

CAUTION

- Do not fully insert probes into the 24-pin plug. Doing so can result in a poor connection.
5. Place the Run/Tow switch in the TOW position and connect the battery cables, positive (+) cable first. **See Connecting the Batteries – Electric Vehicles, Section 1, Page 1-4.**
 6. Place the Run/Tow switch in the RUN position and the Forward/Reverse switch in the NEUTRAL position. The multimeter should indicate zero volts DC at this time.
 7. While monitoring the multimeter, place the Forward/Reverse switch in the REVERSE position. The multimeter should still indicate zero volts.

8. Place the Forward/Reverse switch in the FORWARD position. The multimeter should indicate full battery voltage (approximately 48 volts).
9. Insert the red (+) probe of the multimeter into pin 11 (blue wire) of the 24-pin connector. Leave the black (-) probe (alligator clip) connected to the B- terminal of the speed controller. **See previous CAUTION.**
10. Place the Forward/Reverse switch in the NEUTRAL position. The multimeter should indicate zero volts DC at this time.
11. While monitoring the multimeter, place the Forward/Reverse switch in the FORWARD position. The multimeter should still indicate zero volts.
12. Place the Forward/Reverse switch in the REVERSE position. The multimeter should indicate full battery voltage (approximately 48 volts).
13. If any other reading is obtained, check the following items:
 - Continuity of the wires in the wire harness
 - Forward/Reverse switch for proper operation. **See Forward/Reverse Rocker Switch on page 12-24.**
 - Run/Tow switch for proper operation. **See Run/Tow Switch on page 12-18.**

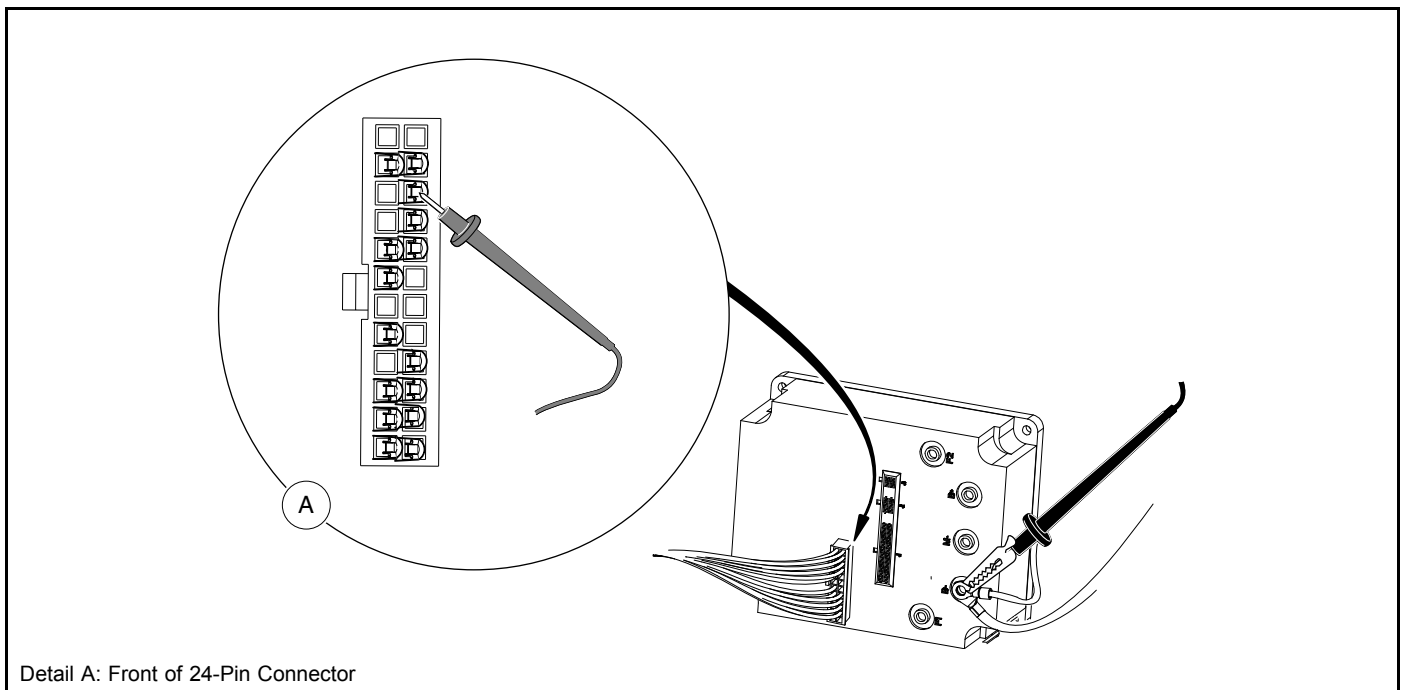

Figure 12-19 Test: Pin 10 (Black Wires)

Pin 1

See General Warnings on page 1-1.

Pin 1 in the 24-pin connector provides a connection point for the key switch to the speed controller. The key switch provides a +48 volt signal to the speed controller through pin 1 (tan wire) when the key switch is in the ON position.

1. Disconnect the batteries and discharge the controller. **See Disconnecting the Batteries – Electric Vehicles, Section 1, Page 1-4.**
2. Place chocks at the front wheels and lift the rear of the vehicle with a chain hoist or floor jack. Position jack stands under the frame crossmember between the spring mount and side stringer, just forward of each rear wheel. **See WARNING “Lift only one end...” in General Warnings on page 1-1.**
3. Disconnect the 24-pin connector at the speed controller.

4. With a multimeter set for 200 volts DC, insert the red (+) probe of the multimeter into pin 1 (tan wire) of the 24-pin connector. **See following CAUTION.** With an alligator clip, connect the black (-) probe to the B- terminal of the speed controller (**Figure 12-20, Page 12-40**).

CAUTION

- Do not fully insert probes into the 24-pin plug. Doing so can result in a poor connection.

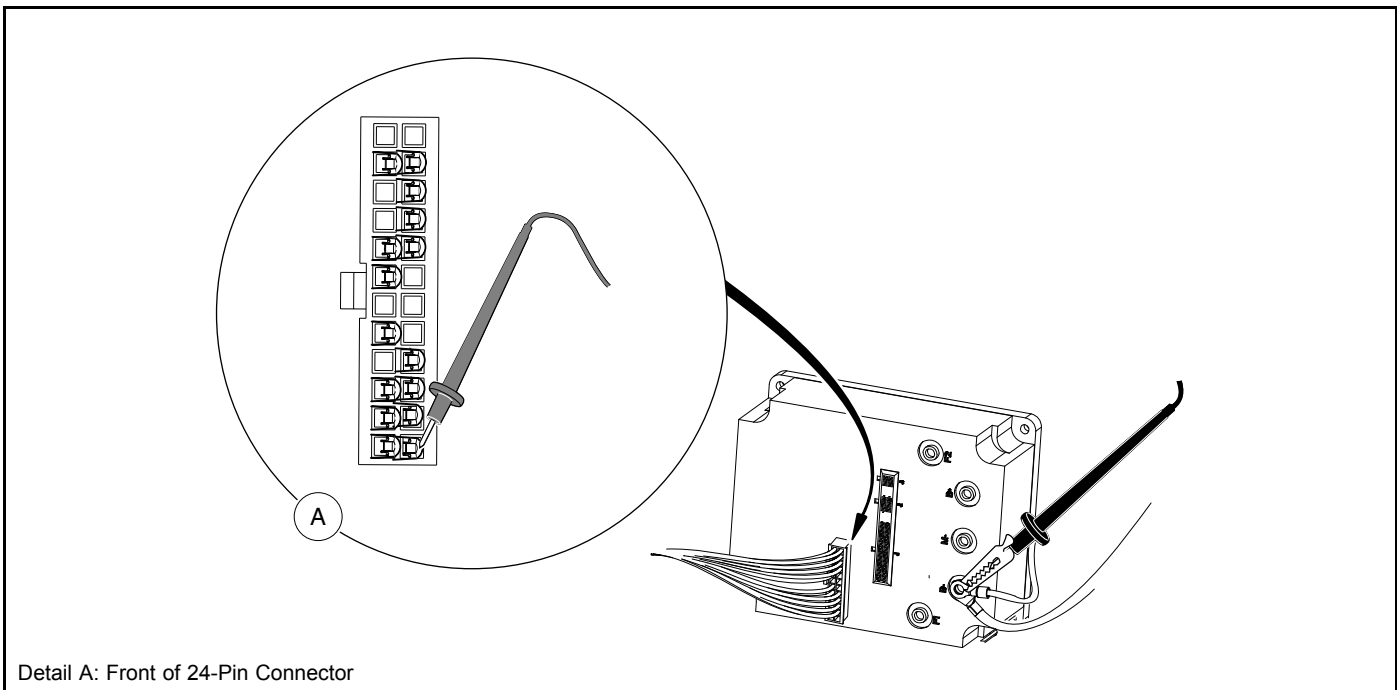

Figure 12-20 Test: Pin 1 (Tan Wire)

5. Place the Run/Tow switch in the TOW position and connect the battery cables, positive (+) cable first. **See Connecting the Batteries – Electric Vehicles, Section 1, Page 1-4.**
6. With the Run/Tow switch in the TOW position, the multimeter should indicate zero volts.
7. Place the Run/Tow switch in the RUN position and the key switch in the ON position.
8. With the key switch in the ON position, the multimeter should indicate full battery voltage (approximately 48 volts). With the key switch in the OFF position, the reading should be zero volts.
9. If any other reading is obtained, check the following items:
 - Continuity of the wires in the wire harness
 - Run/Tow switch for proper operation. **See Run/Tow Switch on page 12-18.**
 - Key switch for proper operation. **See Key Switch and MCOR Limit Switch Circuit on page 12-23.**

Pin 17

See **General Warnings on page 1-1.**

Pin 17 in the 24-pin connector provides a connection point for the solenoid coil to the speed controller. The speed controller activates the solenoid coil by providing a ground to the solenoid coil at the appropriate time.

1. Place chocks at the front wheels and lift the rear of the vehicle with a chain hoist or floor jack. Position jack stands under the frame crossmember between the spring mount and side stringer, just forward of each rear wheel. **See WARNING “Lift only one end...” in General Warnings on page 1-1.**

2. Set a multimeter to 200 volts DC. Use an alligator clip to connect the red (+) probe to the positive terminal on battery no. 1. With an insulation-piercing probe, connect the black (–) probe to the blue/white wire attached to pin 17 of the 24-pin connector.
3. Place the Run/Tow switch in the RUN position, the Forward/Reverse switch in the FORWARD position, and the key switch in the ON position.
4. With the accelerator pedal pressed, the multimeter should read 48 volts DC. With the pedal up, the multimeter should read 0 volts DC.
5. If any other activity is observed, check the following items:
 - Continuity of the wires in the wire harness.
 - Reverse buzzer for proper operation. **See Reverse Buzzer on page 12-42.**
 - Run/Tow switch for proper operation. **See Run/Tow Switch on page 12-18.**
 - Key switch for proper operation. **See Key Switch and MCOR Limit Switch Circuit on page 12-23.**
 - Solenoid for proper operation. **See Solenoid Contacts on page 12-26.**

Pin 3

Voltage is supplied to Pin 3 through the walk away braking circuit breaker:

1. Disconnect the 24-pin connector at the speed controller.
2. With a multimeter set for 200 volts DC, insert the red (+) probe of the multimeter into pin 3 (orange wire) of the 24-pin connector. **See following CAUTION.** With an alligator clip, connect the black (–) probe to the negative terminal of battery # 8.

CAUTION

- **Do not fully insert probes into the 24-pin plug. Doing so can result in a poor connection.**

3. The reading should be 48 volts. If the reading is zero volts, replace the circuit breaker.

Pin 20 (Smart-Key Switch Only)

Voltage is supplied to Pin 20 when it is in the Mode position.

1. With a multimeter set for 200 volts DC, insert the red (+) probe of the multimeter into pin 20 (purple wire) of the 24-pin connector. **See following CAUTION.** With an alligator clip, connect the black (–) probe to the negative terminal of battery # 8.
2. The reading should be 48 volts. If the reading is zero volts, check the purple wire continuity from the key switch to the 24 pin connector. If there is no continuity, replace the keyswitch.

Pin 23

1. Place the Run/Tow switch in the RUN position, the Forward/Reverse switch in the NEUTRAL position, and the key switch in the OFF position.
2. Set the multimeter for 200 volts DC. With an alligator clip, connect the red (+) probe of the multimeter to the positive terminal of battery # 1. With an insulation-piercing probe, connect the black (–) probe to the green/white wire at Pin 23.
3. Push the car to activate walk away braking. When braking activates and reverse buzzer sounds, the reading should be 48 volts.
4. If the reading is zero volts, check the continuity of the green/white wire. If the continuity is good, replace the speed controller.

TEST PROCEDURE 16 – Reverse Buzzer

See General Warnings on page 1-1.

1. Disconnect the batteries and discharge the controller. **See Disconnecting the Batteries – Electric Vehicles, Section 1, Page 1-4.**
2. Remove the instrument panel. **See Instrument Panel Removal, Section 4, Page 4-10.**
3. Place the Run/Tow switch in the TOW position and connect the battery cables, positive (+) cable first. **See Connecting the Batteries – Electric Vehicles, Section 1, Page 1-4.**
4. Place the Run/Tow switch in the RUN position.
5. Set a multimeter to 200 volts DC. Place the black (–) probe on battery no. 8 negative post and place the red (+) probe on the red wire terminal end that was disconnected from the reverse buzzer. The reading should be approximately 48 volts (full battery voltage).
 - 5.1. If the voltage reading is correct, proceed to step 6.
 - 5.2. If reading is zero volts, check red wire continuity and Run/Tow switch. **See Run/Tow Switch on page 12-18.**
 - 5.3. If the continuity readings are not correct, repair or replace the red wire.
 - 5.4. If the continuity readings are correct, proceed to step 6.
6. Place the Forward/Reverse switch in REVERSE. Using a multimeter set to 200 volts DC, place the black (–) probe on the orange/white wire terminal end (that was disconnected from the reverse buzzer) and place the red (+) probe on battery no. 1 positive post. The reading should be approximately 48 volts (full battery voltage).
 - 6.1. If the voltage reading is correct, replace the reverse buzzer.
 - 6.2. If reading is zero volts, check orange/white wire continuity and connection at Pin 19 in 24-Pin connector.
 - 6.3. If there is no continuity in the orange/white wire, or the Pin 19 terminal in the 24-Pin connector is not properly seated, repair or replace as required.
 - 6.4. If the orange/white wire continuity and 24-Pin connector are correct and there is no voltage at the orange wire, replace the controller.

TEST PROCEDURE 17 – Walk Away Braking Relay

See General Warnings on page 1-1.

Walk Away Braking Relay Test with the CDT Handset

1. Turn the key switch to the OFF position and place the Forward/Reverse switch in the NEUTRAL position.
2. Connect the CDT to the vehicle. **See Plugging the CDT into the Vehicle, Section 11, Page 11-2.**
3. Check the FAULTS Menu.
4. If a 15 RELAY DNC or 30 RELAY COIL FAULT is shown in the list, a walk away braking fault has occurred.

Walk Away Braking Relay Test without the CDT Handset

1. Turn the key switch to the OFF position and place the Forward/Reverse switch in the NEUTRAL position.
2. Slowly push the vehicle a short distance (about 3 feet (1 meter)).
3. You should hear the relay click and feel resistance as motor braking is applied. The reverse buzzer will also begin pulsing. If neither of these conditions are present, test the Motor Speed Sensor. **See Motor Speed Sensor on page 12-29.** If the Motor Speed Sensor is operational, replace the walk away braking relay.

TEST PROCEDURE 18 – Charge Indicator Light

See General Warnings on page 1-1.

1. With batteries connected, Run/Tow switch in the RUN position and the key switch in the OFF position, connect charger DC cord to vehicle.
2. In a few seconds, the light will flash three times and the reverse buzzer simultaneously will sound three times to indicate charging has begun. **See following NOTE.**

NOTE: The number of flashes and beeps can vary depending on the Beep Option setting. **See Beep Option, Section 11, Page 11-9.**

3. If charge indicator light does not flash three times, disconnect charger DC cord from vehicle and connect an CDT to the vehicle.
4. Access the Monitor menu and select LED Driver by using the SCROLL DISPLAY buttons. The CDT should indicate OFF.
5. Reconnect charger DC cord to vehicle.
6. In a few seconds, the CDT should quickly display ON just once while the dash-mounted charge indicator light flashes three times. **See following NOTE.**

NOTE: The CDT will still flash ON even with a failed or missing charge indicator light.

7. If the CDT quickly displays ON but the charge indicator light still does not flash, check the following items:
 - Condition of the blue/yellow wire terminal in the 16-pin connector.
 - Condition of the 9-pin connector behind instrument panel.
 - Condition of the yellow/green wire terminal in the instrument panel wire harness.
 - Continuity of the wires in the wire harnesses.
8. If no problems exist in the above items, replace the charge indicator light.

TEST PROCEDURE 19 – 4-Pin Connector (for Connected Car Device)

See General Warnings on page 1-1.

NOTE: This is a voltage and continuity test.

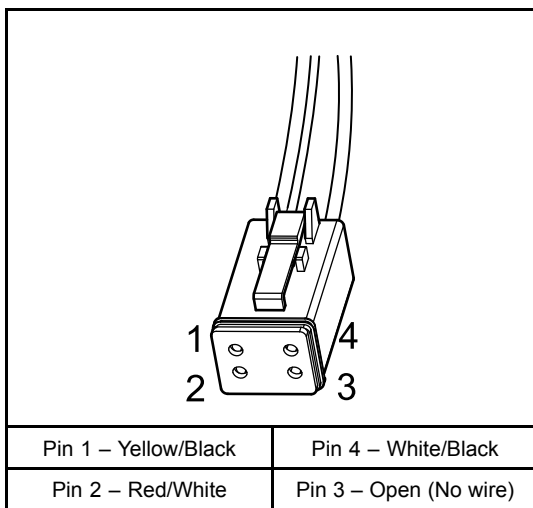

2786

Figure 12-21 4-Pin Connector

1. If necessary, see Testing Basics on page 12-14.

2. Check for continuity between pin 1 (yellow/black wire) (**Figure 12-21, Page 12-43**) and pin 3 (purple/white wire) of the 16-pin connector. It should indicate continuity. If not, check sonic welds no. 1 and no. 2.
3. Probe pin 2 (red/white wire). It should show BPV. If not, check 2-amp fuse. **See following NOTE.**

NOTE: The red/white wire has BPV with the Run/Tow switch in either position.

4. Probe pin 4 (white/black wire). It should show approximately 13 volts supplied by the controller. If not, check wiring and then controller. **See following NOTE.**

NOTE: The white/black wire only has voltage with the Run/Tow switch in the RUN position.

If pin 4 has no voltage, the controllers LIN (Local Interconnect bus) may have failed. The vehicle can be driven if it is not used with Guardian or Visage and will not show any symptoms. Otherwise, Guardian or Visage will disable the vehicle until communication is restored.

⚠ DANGER

- See General Warnings on page 1-1.

⚠ WARNING

- See General Warnings on page 1-1.

KEY SWITCH

See General Warnings on page 1-1.

TESTING THE KEY SWITCH

See Test Procedure 7 – Key Switch and MCOR Limit Switch Circuit on page 12-23.

KEY SWITCH REMOVAL

1. Disconnect the batteries and discharge the controller. **See Disconnecting the Batteries – Electric Vehicles, Section 1, Page 1-4.**
2. Remove instrument panel. Refer to **See Instrument Panel Removal on page 4-10.**

***NOTE:** Take care to prevent key switch terminals and wires from touching the metal frame around the dash.*

3. Disconnect the wires from the key switch. Do not allow wires to touch.
4. From the back of the instrument panel, push down on the retaining tabs surrounding the key switch (4) and remove the key switch cap (8). Using a 1-inch socket, hold the key switch and remove the switch retaining nut (6) from the outside of the instrument panel (**Figure 13-1, Page 13-2**).

KEY SWITCH INSTALLATION

1. Position the key switch (3) and key switch washer (1) in the instrument panel, then install and tighten the key switch nut (5) to 35 to 45 in·lb (4 to 5 N·m). Install key switch cap (6) into instrument panel, align the bent washer tab with the slot in the plastic. (**Figure 13-1, Page 13-2**)
2. Refer to the wiring diagram to connect the wires to the key switch terminals. **See Wiring Diagrams, Section 12, Page 12-4.**
3. Install instrument panel. **See Instrument Panel Installation on page 4-10.**
4. Connect the batteries. **See Connecting the Batteries – Electric Vehicles, Section 1, Page 1-4.**

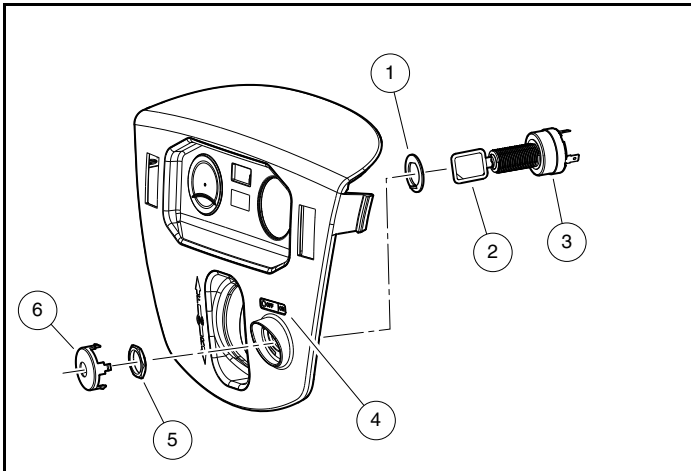

Figure 13-1 Key Switch

FORWARD/REVERSE ROCKER SWITCH

See General Warnings on page 1-1.

TESTING THE FORWARD/REVERSE ROCKER SWITCH

See Test Procedure 8 – Forward/Reverse Rocker Switch on page 12-24.

FORWARD/REVERSE ROCKER SWITCH REMOVAL

1. Disconnect the batteries and discharge the controller. **See Disconnecting the Batteries – Electric Vehicles, Section 1, Page 1-4.**
2. Remove the instrument panel. **See Instrument Panel Removal, Section 4, Page 4-10.**
3. Disconnect the 18-gauge brown, orange, and red/green wires from the rocker switch.
4. Press the locking tabs on each end of switch and push switch out of instrument panel.

FORWARD/REVERSE ROCKER SWITCH INSTALLATION

1. Press the locking tabs on each end of the rocker switch and push switch into instrument panel.
2. Connect the 18-gauge brown, orange, and red/green wires to the rocker switch exactly as shown in the wiring diagram. **See Wiring Diagrams, Section 12, Page 12-4.**
3. Install instrument panel. **See Instrument Panel Installation on page 4-10.**
4. Connect the batteries. **See Connecting the Batteries – Electric Vehicles, Section 1, Page 1-4.**
5. Place the Run/Tow switch in the RUN position.
6. Inspect the vehicle for proper operation. **See following WARNINGS.**

⚠ WARNING

- **Make sure that the vehicle operates in the forward direction when the Forward/Reverse switch is in the FORWARD position.**
- **Make sure that the vehicle operates in the reverse direction when the Forward/Reverse switch is in the REVERSE position. The reverse buzzer will sound as a warning when the Forward/Reverse switch is in REVERSE.**
- **Make sure that the vehicle does not operate when the Forward/Reverse switch is in the NEUTRAL position.**

RUN/TOW SWITCH

See General Warnings on page 1-1.

TESTING THE Run/Tow SWITCH

See Test Procedure 3 – Run/Tow Switch on page 12-18.

RUN/TOW SWITCH REMOVAL

1. Disconnect the batteries and discharge the controller. **See Disconnecting the Batteries – Electric Vehicles, Section 1, Page 1-4.**
2. Using a 5/8 in (16 mm) socket, remove Run/Tow switch boot/hex nut (6).
3. Remove Run/Tow switch (10) and nut (9) from bracket (5).
4. Disconnect the two-pin connector (7) and remove switch.

RUN/TOW SWITCH INSTALLATION

1. Installation is reverse of removal. Make sure groove on switch is aligned with tang on bracket. Tighten Run/Tow switch boot/hex nut (6) to 16 in·lb (1.8 N·m).
2. Connect the batteries. **See Connecting the Batteries – Electric Vehicles, Section 1, Page 1-4.**

CIRCUIT BREAKER

See General Warnings on page 1-1.

TESTING THE CIRCUIT BREAKER

See Test Procedure 5 – Circuit Breaker on page 12-20

CIRCUIT BREAKER REMOVAL

1. Disconnect the batteries and discharge the controller. **See Disconnecting the Batteries – Electric Vehicles, Section 1, Page 1-4.**
2. Remove the plastic nut (1) from the circuit breaker (**Figure 13-2, Page 13-5**).
3. Remove circuit breaker and metal nut (2) from bracket (3).
4. Disconnect tan and green wires from the spade connectors (4) on the back of the circuit breaker.

CIRCUIT BREAKER INSTALLATION

1. Installation is reverse of removal. Connect tan and green wires to the spade connectors (4) on the back of the circuit breaker. **See following NOTE.**

NOTE: *The spade connectors are not polarity-sensitive. It does not matter what color wire goes to either of the spade connectors.*

2. Insert the circuit breaker and metal nut (2) into the bracket (3).
3. Replace the plastic nut (1) on the circuit breaker.
4. Connect the batteries. **See Connecting the Batteries – Electric Vehicles, Section 1, Page 1-4.**

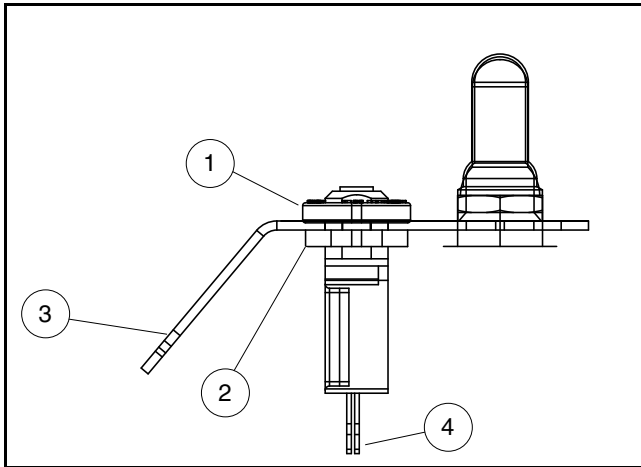

Figure 13-2 Circuit Breaker

MOTOR CONTROLLER OUTPUT REGULATOR (MCOR)

See General Warnings on page 1-1.

TESTING THE MCOR

See Test Procedure 12 – MCOR Voltage on page 12-27 and Test Procedure 7 – Key Switch and MCOR Limit Switch Circuit on page 12-23.

MCOR REMOVAL

1. Disconnect the batteries and discharge the controller. **See Disconnecting the Batteries – Electric Vehicles, Section 1, Page 1-4.**
2. Place chocks at rear wheels and lift the front of the vehicle with a chain hoist or floor jack. Place jack stands under the round tube crossmember of the frame to support vehicle.
3. Disconnect the two-pin and three-pin connectors (1) from the MCOR (2) (**Figure 13-3, Page 13-6**).
4. Remove the two torx screws (3) securing the MCOR (2) to the plastic housing (4) on the chassis.
5. Detach the two tabs from the plastic housing (4) and remove the MCOR (2) from vehicle.

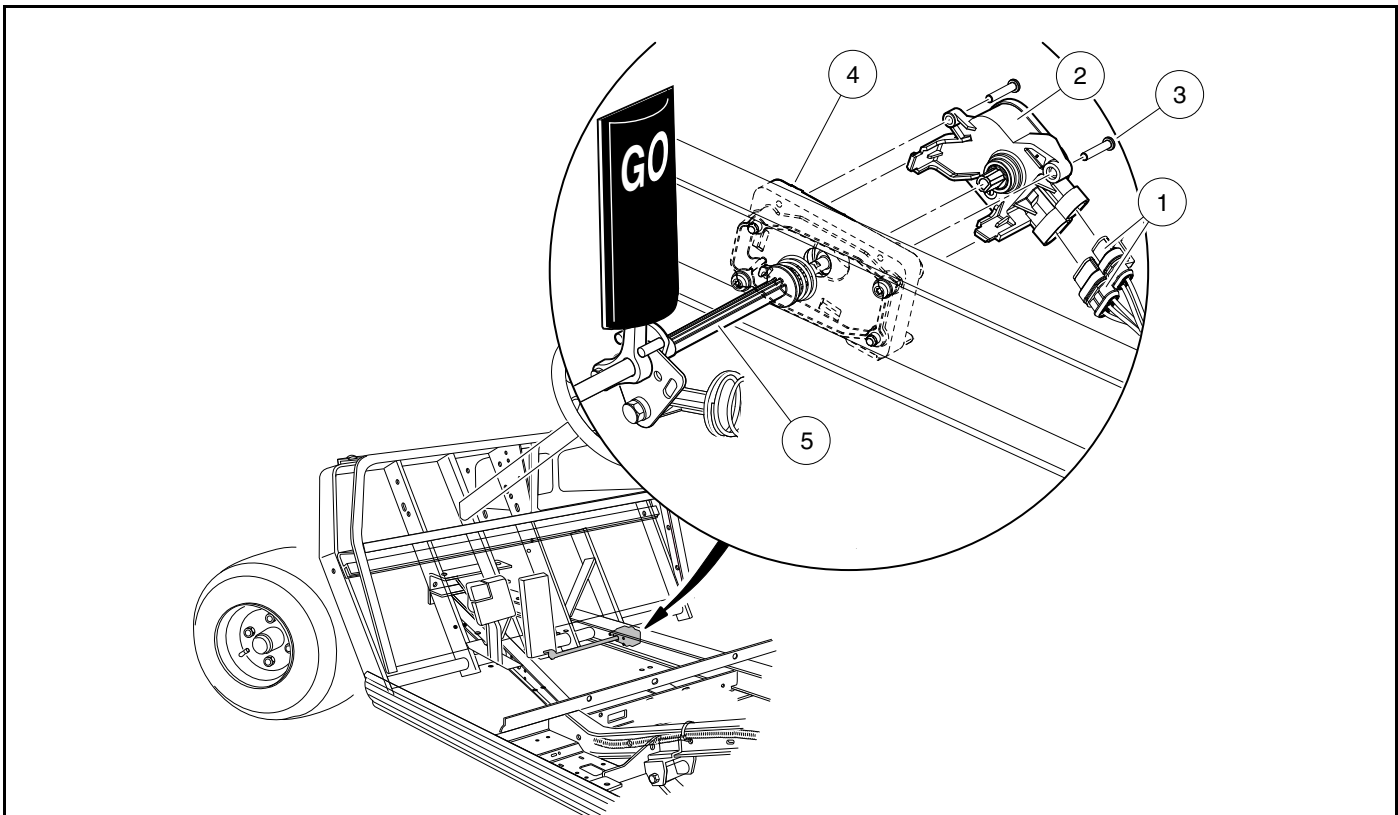

2646

Figure 13-3 MCOR Mounting

MCOR INSTALLATION

1. Align the two tabs of the MCOR (2) with the slots in the plastic housing (4) on the chassis (**Figure 13-3, Page 13-6**). Insert the MCOR into the plastic housing (4) until the tabs engage. **See following NOTE.**

NOTE: Rotate the drive bar (5) back and forth if necessary to align the D-shaped end with the MCOR.

2. Secure the MCOR (2) to the plastic housing (4) with two torx screws (3). Tighten screws to 12 in·lb (1.4 N·m).
3. Connect the two-pin and three-pin connectors (1) from the wire harness to the MCOR (2).
4. Connect the batteries. **See Connecting the Batteries – Electric Vehicles, Section 1, Page 1-4.**

REVERSE BUZZER

See General Warnings on page 1-1.

TESTING THE REVERSE BUZZER

See Test Procedure 16 – Reverse Buzzer on page 12-42.

REVERSE BUZZER REMOVAL

1. Disconnect the batteries and discharge the controller. **See Disconnecting the Batteries – Electric Vehicles, Section 1, Page 1-4.**
2. Remove the instrument panel. **See Instrument Panel Removal, Section 4, Page 4-10.**
3. Disconnect the 18-gauge pink and orange/white wires from reverse buzzer.
4. Remove the two screws from the reverse buzzer. Remove the reverse buzzer from the center dash panel.

REVERSE BUZZER INSTALLATION

1. Install the reverse buzzer in the reverse order of removal. Tighten screws to 4 in·lb (0.45 N·m).
2. Connect the batteries. **See Connecting the Batteries – Electric Vehicles, Section 1, Page 1-4.**

SPEED CONTROLLER COVER

REMOVING THE SPEED CONTROLLER COVER

1. Use a flathead screwdriver to pry up the center pieces of the 3 push rivets (5) and remove the rivets (**Figure 13-5, Page 13-10**).
2. Pull the speed controller cover (9) down and away from the component mounting plate.
3. Lift the curved edges of the speed controller cover out of the slots in the component mounting plate.

INSTALLING THE SPEED CONTROLLER COVER

1. Place the curved edges on the bottom of the speed controller cover into the slots on the component mounting plate.
2. Press the speed controller cover onto the component mounting plate over the speed controller and other electrical components.
3. Install the three push rivets (5) (**Figure 13-5, Page 13-10**).

SOLENOID

See General Warnings on page 1-1.

The solenoid is located on the passenger side of the electrical component mounting plate.

TESTING THE SOLENOID

See Test Procedure 9 – Solenoid Activating Coil on page 12-25 and Test Procedure 10 – Solenoid Contacts on page 12-26.

SOLENOID REMOVAL

1. Disconnect the batteries and discharge the controller. **See Disconnecting the Batteries – Electric Vehicles, Section 1, Page 1-4.**
2. Remove the speed controller cover. **See Removing the Speed Controller Cover on page 13-7.**
3. Disconnect all wires from the solenoid (**Figure 13-4, Page 13-8**).
4. Loosen, but do not remove, the two screws (1) that hold the solenoid (2) to the component mounting plate.
5. Lift the solenoid (2) up and off of the component mounting plate.

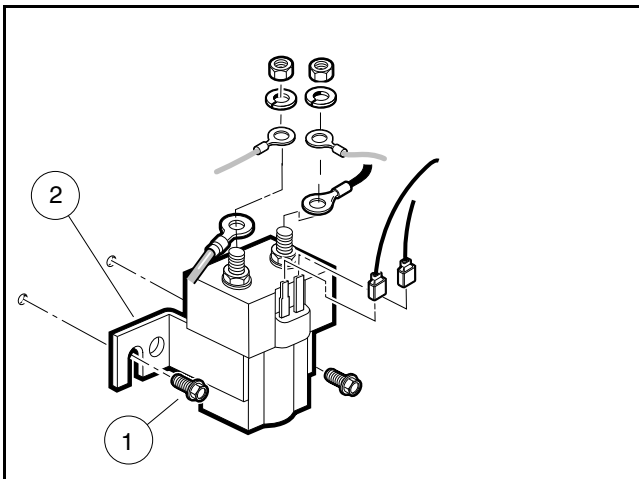

Figure 13-4 Solenoid

SOLENOID INSTALLATION

1. Mount solenoid (2) onto component mounting plate with screws (1) (**Figure 13-4, Page 13-8**).
2. Tighten screws (1) to 60 in·lb (6.8 N·m).
3. Using the wiring diagram, install the wires, washers, and nuts onto the large mounting posts. Tighten nuts to 77 in·lb (8.7 N·m). **See Wiring Diagrams, Section 12, Page 12-4.**
4. Install the blue/white and light blue wires onto the small terminals of the solenoid (**Figure 13-4, Page 13-8**).
5. Install speed controller cover. **See See Installing the Speed Controller Cover on page 13-7.**
6. Connect the batteries. **See Connecting the Batteries – Electric Vehicles, Section 1, Page 1-4.**

SPEED CONTROLLER

See General Warnings on page 1-1.

TESTING THE SPEED CONTROLLER

See Test Procedure 14 – A1 and A2 Motor Voltage on page 12-32.

SPEED CONTROLLER REMOVAL

1. Disconnect the batteries and discharge the controller. **See Disconnecting the Batteries – Electric Vehicles, Section 1, Page 1-4.**
2. Remove the speed controller cover. **See Removing the Speed Controller Cover on page 13-7.**
3. Disconnect all wires and multi-pin connectors from the speed controller.
4. Remove the four bolts that hold the speed controller to the component mounting plate and remove the controller from the vehicle.

SPEED CONTROLLER INSTALLATION

1. Install the four bolts (12) that hold the speed controller (23) to the component mounting plate and tighten to 50 in·lb (5.6 N·m) (**Figure 13-5, Page 13-10**).
2. Using the wiring diagram, install the multi-pin connectors and all wires as illustrated. **See Wiring Diagrams, Section 12, Page 12-4.** Tighten bolts (8) to 13.5 ft·lb (18.3 N·m). Tighten bolts (22) to 11 ft·lb (14.9 N·m) (**Figure 13-5, Page 13-10**).
3. Install the speed controller cover. **See Installing the Speed Controller Cover on page 13-7.**
4. Connect the batteries. **See Connecting the Batteries – Electric Vehicles, Section 1, Page 1-4.**
5. Place the Run/Tow switch in the RUN position.
6. Inspect the vehicle for proper operation:
 - Make sure that the vehicle operates in the forward direction when the Forward/Reverse switch is in the FORWARD position.
 - Make sure that the vehicle operates in the reverse direction when the Forward/Reverse switch is in the REVERSE position. The reverse buzzer will sound as a warning when the Forward/Reverse switch is in REVERSE.
 - Make sure that the vehicle does not operate when the Forward/Reverse switch is in the NEUTRAL position.

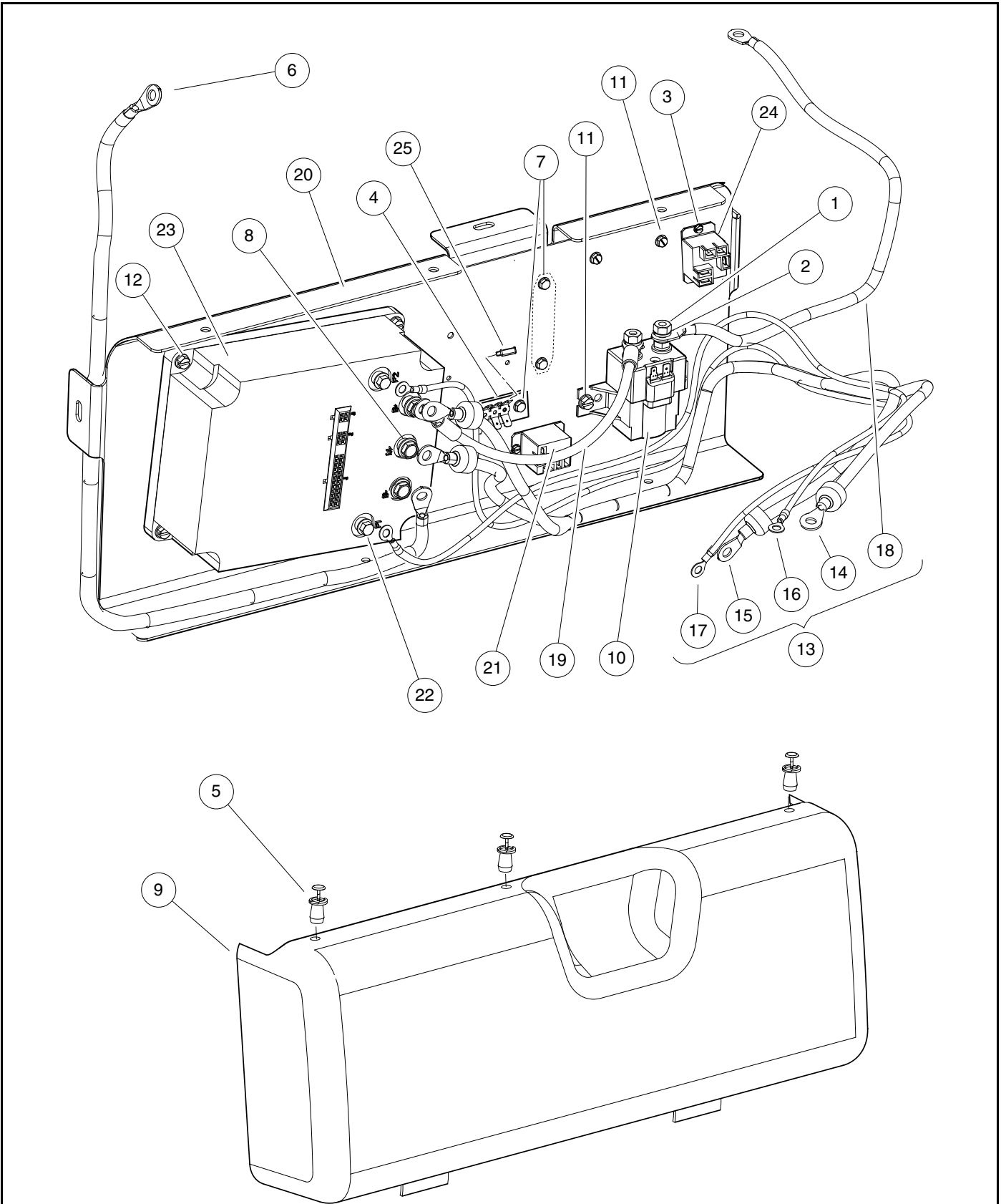

2998

Figure 13-5 Speed Controller

CHARGE INDICATOR LIGHT

See General Warnings on page 1-1.

TESTING THE CHARGE INDICATOR LIGHT

See Test Procedure 18 – Charge Indicator Light on page 12-42.

CHARGE INDICATOR LIGHT REMOVAL

1. Disconnect the batteries and discharge the controller. **See Disconnecting the Batteries – Electric Vehicles, Section 1, Page 1-4.**
2. Remove instrument panel. **See Instrument Panel Removal on page 4-10.**
3. Disconnect the wires at the warning light.
4. Press the two retaining tabs and remove the light from the instrument panel.

CHARGE INDICATOR LIGHT INSTALLATION

1. Install light into instrument panel.
2. Connect wires to the warning light.
3. Install the instrument panel. **See Instrument Panel Installation on page 4-10.**
4. Connect the batteries. **See Connecting the Batteries – Electric Vehicles, Section 1, Page 1-4.**

Pagination Page

⚠ DANGER

- See General Warnings on page 1-1.

⚠ WARNING

- See General Warnings on page 1-1.

⚠ DANGER

- **Battery – Explosive gases! Do not smoke. Keep sparks and flames away from the vehicle and service area. Ventilate when charging or operating vehicle in an enclosed area. Wear a full face shield and rubber gloves when working on or near batteries.**
- **Charge batteries in a well-ventilated area only. Batteries emit hydrogen while being charged. Hydrogen is an explosive gas and must never exceed a level of 2% of the air.**
- **Battery – Poison! Contains acid! Causes severe burns. Avoid contact with skin, eyes, or clothing. Antidotes:**
 - **External: Flush with water. Call a physician immediately.**
 - **Internal: Drink large quantities of milk or water. Follow with milk of magnesia or vegetable oil. Call a physician immediately.**
 - **Eyes: Flush with water for 15 minutes. Call a physician immediately.**

⚠ WARNING

- **Wear safety glasses or approved eye protection when servicing the vehicle or battery charger. Wear a full face shield and rubber gloves when working on or near batteries.**
- **Use insulated tools when working near batteries or electrical connections. Use extreme caution to avoid shorting of components or wiring.**
- **Ensure battery connections are clean and properly tightened. See Battery Care on page 14-6.**

CAUTION

- **On all vehicles, turn off all accessories before charging batteries.**

NOTE: Recycle or dispose of discarded batteries in accordance with local, state, and federal regulations.

GENERAL INFORMATION

The batteries supplied with an electric vehicle are different from those supplied with an automobile. The outward appearance of these two batteries is similar, but the operating characteristics are very different. The electric vehicle battery is a deep-cycle battery, and the automotive battery is a “starting, lighting, and ignition” (SLI) battery. They should never be substituted for one another.

BATTERY TESTING BASICS – 6 VOLT

See General Warnings on page 1-1.

OBSERVATION

Inspect the battery compartment for the following items:

- Rusted, corroded, or broken battery posts
- Rusted, corroded, loose or broken wires
- Low or overfilled electrolyte levels
- Cracked, punctured, or bulging battery cases
- Loose, over-tightened, missing, or improperly placed battery hold-downs
- Incorrect orientation of batteries (i.e. terminal posts)
- Poor, fair, or proper cleanliness of batteries
- Added electric accessories
- Use of a single-point watering system (SPWS)

MEASURING VOLTAGE OF BATTERY SET

Set the multimeter to 200 volts DC. Place the red (+) probe on the positive (+) post of battery no. 1 and the black (–) probe on the negative (–) post of battery no. 8. Record the reading.

BATTERY CELL NUMBERING

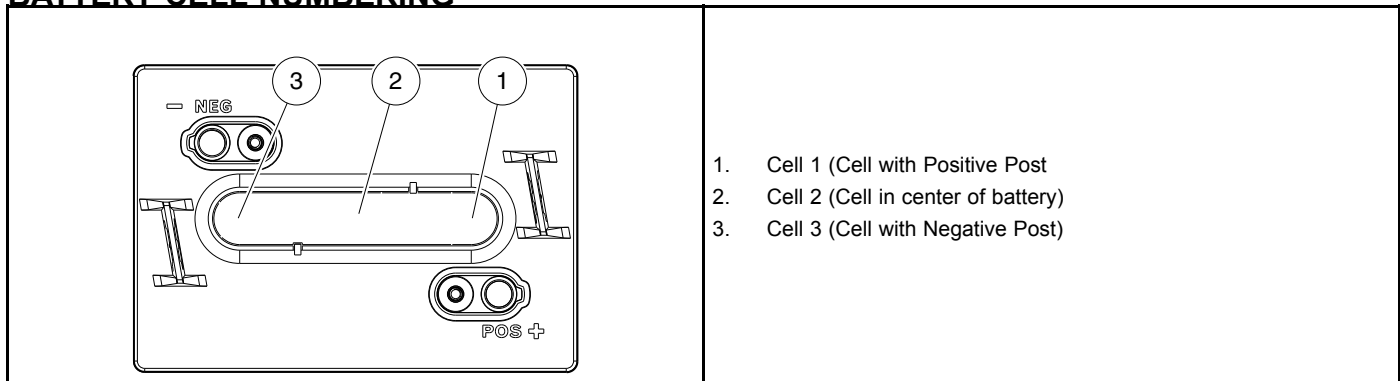

2947

Figure 14-1 Battery Cell Numbering – 6 Volt

BATTERY TESTING – 6 VOLT

See General Warnings on page 1-1.

Test procedures not available at time of publication. Refer to any Bulletin that is released concerning testing for Model Year 2015.

BATTERY REGROUPING

CAUTION

- **To prevent degradation of battery performance and life, never mix batteries of different part numbers or brands/model numbers. Anytime a different model of battery is used, the charging algorithm must be changed to match it. For vehicles with PowerDrive charger, the vehicles' onboard computer must be changed to one that is specific to the battery installed. For vehicles with high-frequency charger (e.g. ERIC or QuiQ), the charger must be reprogrammed with the appropriate algorithm specific to the battery installed.**

Regrouping is now Club Car's standard battery replacement method. *Regrouping* is the practice of placing batteries of similar condition together in one vehicle. For example, if there was an issue with the batteries in two cars and the battery test indicated three failed batteries in each car, after removing the failed batteries, there will be six good batteries remaining. Install the six remaining good batteries together in one car and install NEW batteries in the other car. We recommend regrouping batteries in as many cars as possible at a given opportunity to minimize mixing old and new batteries together in one battery pack. A training video for regrouping is available to view in the Partner Pavilion under "Tech/Warranty" and then "Training Videos". Contact your regional Tech Support person to assist you in the regrouping process if needed.

BATTERY REGROUPING PROCESS FLOW (6 volt, 8 volt, and 12 volt batteries)

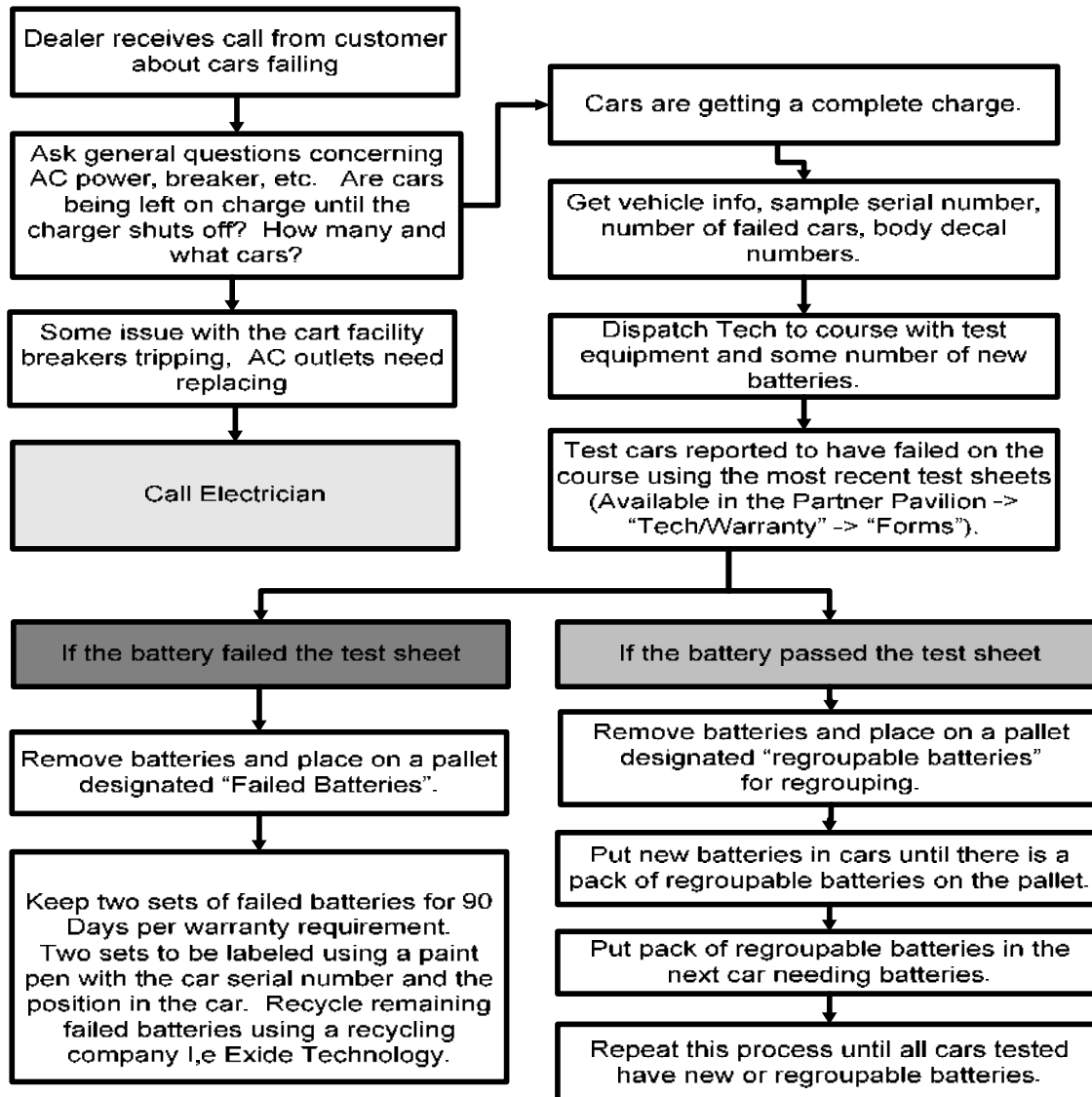

CAUTION: To prevent degradation of battery performance and life, never mix batteries of different part numbers or brands/model numbers. Charging algorithms are specific to a particular battery model.

1. Install all new batteries or all regroupable batteries of the same brand and model or part number; do not mix new with regroupable except for the last car regrouped.
2. Accurate and accumulative Amp Hours are required for Warranty claims. Make sure to have battery lights on hand to replace ones that may be defective so you can capture every car's Amp Hour reading.

BATTERY REPLACEMENT

See General Warnings on page 1-1.

⚠ WARNING

- Wear steel-toe shoes when replacing batteries.
- To prevent electrolyte leakage from the battery vents, batteries must be kept in an upright position. Tipping a battery beyond a 45° angle in any direction can allow a small amount of electrolyte to leak out the vent hole. Do not exceed this 45° angle when lifting, carrying, or installing batteries. Battery acid can cause severe personal injury to skin or eyes, and can damage clothing.
- When replacing batteries in the Single Point Watering System, place the battery cap from the new replacement battery onto the used battery being removed from the car. Important safety warnings on the battery cap must remain with the battery after it has been removed from the car

CAUTION

- To prevent degradation of battery performance and life, never mix batteries of different part numbers or brands/model numbers. Anytime a different model of battery is used, the charging algorithm must be changed to match it. For vehicles with PowerDrive charger, the vehicles' onboard computer must be changed to one that is specific to the battery installed. For vehicles with high-frequency charger (e.g. ERIC or QuiQ), the charger must be reprogrammed with the appropriate algorithm specific to the battery installed.
1. Before removing batteries, note the orientation of the batteries and the connecting wires. Disconnect the battery cables and discharge the controller as instructed. **See Disconnecting the Batteries – Electric Vehicles on page 1-4.** Remove remaining wires and batteries.
 2. Visually inspect the new batteries for any damage that may have occurred in transit. New batteries will not deliver their full capabilities until they have been discharged and recharged 50 to 70 times. To obtain the maximum service life from new batteries, restrict vehicles with new batteries to one hour of operation between charges for the first two months vehicle is in service. Batteries should be fully charged before first use of new vehicle, before first use of a vehicle after storage, and before use each day.
 3. If the battery cables are to be reused, inspect them for broken or frayed wires, damaged terminals, or worn insulation. Remove any corrosion on the connectors. A solution of baking soda and water (1 cup (237 mL) baking soda per 1 gallon (3.8 L) of water) does an excellent job of neutralizing and removing the corrosion. Be careful not to allow the baking soda solution to enter the battery.
 4. Check and clean the battery rack and hold-downs. The nuts and bolts on the hold-downs may corrode. It is therefore advised they be cleaned periodically and replaced as necessary.
 5. Regroup batteries as required. **See Battery Regrouping on page 14-3.**
 6. Install regrouped or new batteries in the proper orientation. **See Connecting the Batteries – Electric Vehicles, Section 1, Page 1-4.** Install battery hold-downs. The hold-downs should be tight enough so batteries do not move while vehicle is in motion, but not so tight as to crack or buckle battery case. Tighten hold-down retaining nuts to 72 in·lb (8.1 N·m), alternating between hold-down bolts.
 7. Install wires in proper sequence. Install black wire to negative post of battery no. 8 (8 x 6-Volt battery set) last. **See Connecting the Batteries – Electric Vehicles on page 1-4.**
 8. Give the batteries a full charge prior to operation. This ensures all the batteries are fully charged and the cells are equalized prior to use.

BATTERY CARE

See General Warnings on page 1-1.

WATER QUALITY

Water purity is the most important factor in the performance and life span of the vehicle batteries. Club Car is, therefore, placing increased importance on battery water quality.

Outlined below are four battery watering procedures, grouped into two categories: Preferred and Alternate methods. Club Car recommends the use of a deionizer or distilled water. Alternate methods of reverse osmosis or tap water are allowable but should be avoided since water quality can change from day to day depending on additives, water main leaks, etc.

Preferred Methods

- **Distilled Water:** Distilled water is the most common type of water used in batteries. Distilled water is created by boiling water, collecting the steam, and allowing the steam to condense back into water. The distilling process results in water that is free of minerals that can lead to the degradation of battery performance and life.
- **Deionized Water:** Deionized water is created by inducing electrically charged resins that attract and bind to sodium, calcium, iron, copper, chloride, and bromide ions. The result of this electrical filtering is purified water, which contains little to no mineral ions. To make sure the deionized water remains at a high quality, replace the filter in the deionizer per the manufacturer's recommendations.
- **Deionized Systems:** The Service Parts Department at Club Car offers one deionizer system: for vehicles equipped with the Single Point Watering System (SPWS), CC P/N 105166801; for vehicles without SPWS, CC P/N 105166801 (used in combination with AM10818 Battery Watering Nozzle Gun).

Alternate Methods

- **Reverse Osmosis:** Reverse osmosis involves forcing water through a membrane that allows water to pass while trapping solids. The choice of membrane used determines the amount of solids or impurities that get trapped and hence the purity quality of the filtered water. In addition, the usage frequency of the membrane can also contribute to the filtered water quality. Due to the variance in water quality consistency, Club Car recommends the use of the deionizer or distilled water.
- **Tap Water:** While the use of tap water without filtering is an alternate method of battery watering, its use should be limited due to the levels of dissolved minerals and chemicals that can degrade battery performance and life. If unfiltered tap water is used, regular water analyses must be conducted to check for impurities. The following chart lists the maximum allowable minerals, solids, and contaminants in parts per million and their impact on battery performance. Water testing, however, is expensive, and water quality can change from day to day depending on additives, water main leaks, etc. Due to the cost and labor of performing water quality tests, Club Car recommends the use of distilled water or a deionizer.

IMPURITY	ALLOWABLE CONTENT (PARTS PER MILLION)	EFFECTS OF IMPURITY
Suspended matter	Trace	N/A
Total solids	100.0	N/A
Organic and volatile matter	50.0	Corrosion of positive plates
Ammonia	8.0	Slight self-discharge of both plates

TABLE CONTINUED ON NEXT PAGE

IMPURITY	ALLOWABLE CONTENT (PARTS PER MILLION)	EFFECTS OF IMPURITY
Antimony	5.0	Self-discharge, reduces life, lower on-charge voltage
Arsenic	0.5	Self-discharge, can form poisonous gas
Calcium	40.0	Increase of positive plate shedding
Chloride	5.0	Loss of capacity in plates, greater loss in positive plates
Copper	5.0	Increased self-discharge, lower on-charge voltage
Iron	3.0	Increased self-discharge, lower on-charge voltage
Magnesium	40.0	Reduced life
Nickel	None allowed	Intense lowering of on-charge voltage
Nitrates	10.0	Increased sulfation of negative plate
Nitrites	5.0	Plate corrosion, loss of capacity, reduced life
Platinum	None allowed	Violent self-discharge, lower on-charge voltage
Selenium	2.0	Positive plate shedding
Zinc	4.0	Slight self-discharge of negative plates

DEIONIZER

Deionizer systems for SPWS configured fleets became standard with Model Year 2014 fleet golf orders.

Regular Maintenance

This system requires regular preventative maintenance on at least a quarterly basis.

- Check all screens and/or filters on water supplies. Clean or replace all filters / line strainers as necessary. Failure to do so can cause a reduction in the water pressure and flow rates needed to operate the system properly. A filter screen can be found on the inlet of all regulators, and a line strainer on all supply hoses. Be sure to replace the deionizer filter cartridge as indicated by the water quality light. The CC P/N 105166801 Deionizer system has a battery-powered, water quality light. Deionizer filters have a limited life cycle and are disposable. Life cycle of the filter will vary based on incoming water quality and water usage. If the deionizer system is equipped with a water quality light, press the button to check. Replace filter immediately if the red light comes ON indicating service is required.

The following replacement filter is available from Club Car Service Parts:

- Use filter P/N 104005901 for Deionizer Systems P/N's 105166801, 104006001, and AM10974.
- Use filter P/N AM10975 for Deionizer System P/N AM10974.

NOTE: The filter P/N AM10975 will be sold to depletion. After this part becomes unavailable, use the filter P/N 104005901 for Deionizer System P/N AM10974.

- Inspect the condition of all tubing, connections, and couplers. Make sure that all parts are in good working condition, secure, leak free, and properly connected. The coupler must have an O-ring and the dust cover properly attached.
- Clean optical indicator of the water quality light. If the optical indicator is dirty, clean it by wiping with a cloth.

Decals

Starting December 2013, new decals were installed on the deionizer wall bracket and the deionizer filter. The blue, deionizer wall bracket decal is a Filter Replacement Record Log. The yellow filter decal is a Fleet Inspection Record

Log. Use these decals to record filter replacement activity and fleet inspection activity. For convenience, both decals have a QR code for ordering replacement filters.

Seasonal Maintenance

Water supplies must be drained and stored in an empty state if they will be exposed to freezing temperatures. Failure to do so can cause permanent damage.

Single point watering systems will require seasonal maintenance if vehicles are taken out of service or put into storage for a period of 6 weeks or longer. To prepare the SPWS, ensure the feed tube and coupler are on top of battery. Then, use the following steps to bring vehicle back into service:

1. After the batteries have been fully charged/equalized, connect the system to its water supply for 3 to 5 seconds, then disconnect regardless of whether or not the batteries are completely full.
2. Return the vehicle to normal operation.
3. Place the vehicle back into its regular watering schedule, waiting at least one week until next watering.

BATTERY CARE – VEHICLES EQUIPPED WITH THE SINGLE-POINT WATERING SYSTEM (SPWS)

To keep batteries in good working condition, follow this maintenance program on a regular basis:

1. Keep the batteries clean and free of corrosion. Wash tops and terminals of batteries with a solution of baking soda and water; use 1 cup (237 mL) baking soda per 1 gallon (3.8 L) of water. Rinse solution off of the batteries. Do not allow this solution to enter the battery. Be sure terminals are tight. Let the terminals dry and then coat with Battery Terminal Protector Spray. **See following NOTE.**

NOTE: *Dispose of waste water properly.*

2. The battery hold-downs should be tight enough so that the batteries do not move while the vehicle is in motion, but not so tight as to crack or buckle the battery case. Tighten hold-down retaining nuts to 55 in-lb (6.2 N-m). The terminal connections should be clean and tight, and any worn insulation or frayed wires should be replaced. Tighten battery terminals to proper torque. **See Connecting the Batteries – Electric Vehicles on page 1-4. See following WARNING.**

⚠ WARNING

- **If battery wire terminals are damaged or corroded, replace or clean them as necessary. Failure to do so can cause them to overheat during operation and can result in fire, property damage, or personal injury.**
3. After use, charge the batteries. The batteries should never be left discharged any longer than absolutely necessary (do not leave discharged overnight).
 4. Water the batteries monthly or according to the watering interval. **See Establishing the Watering Interval for New Vehicles on page 14-9. See Watering Batteries with the SPWS on page 14-11.**

CAUTION

- **The watering interval must adequately maintain the electrolyte level above the top of the plates (Figure 14-3, Page 14-10).**
- **Water the batteries only AFTER charging.**

NOTE: *Bottled distilled water, with the hand pump, CC PN 104006101, is recommended for private consumer SPWS applications.*

Establishing the Watering Interval for New Vehicles

If you do not already have a battery watering interval for your vehicles, manually check the battery water level weekly to establish the correct watering interval. Thereafter, water batteries according to the established interval. During periods of heavy use, add additional watering as required.

Single-Point Watering System (SPWS) Maintenance

1. For vehicles newly equipped with the Single-Point Watering System, the initial electrolyte level check on all battery cells verifies that all the valves in the SPWS are functioning correctly. **See Periodic Service Schedules on page 10-4.** If a valve fails to open, the cell will eventually dry out. The initial one-time inspection of all cells will identify any occurrence of a valve that fails to open. If a valve fails to close, it will become evident due to the cell overflowing during routine watering. Either failure scenario is rare, but should be monitored in the initial inspection and during routine watering sessions. Replace malfunctioning valves to ensure maximum battery life. **See following CAUTION.**

CAUTION

- **After checking the electrolyte, fully tighten the battery caps to prevent electrolyte leakage.**
2. After the initial six-week inspection, manually check the electrolyte level at least once per year, particularly after long-term storage or any other period of vehicle inactivity. **See preceding CAUTION.**

BATTERY CARE – VEHICLES WITHOUT THE SINGLE-POINT WATERING SYSTEM (SPWS)

To keep batteries in good working condition, follow this maintenance program on a regular basis:

1. Keep the batteries clean and free of corrosion. Wash tops and terminals of batteries with a solution of baking soda and water; use 1 cup (237 mL) baking soda per 1 gallon (3.8 L) of water. Rinse solution off of the batteries. Do not allow this solution to enter the battery. Be sure terminals are tight. Let the terminals dry and then coat with Battery Terminal Protector Spray. **See following NOTE.**

NOTE: Dispose of waste water properly.

2. Check the electrolyte level weekly (**Figure 14-3**). Add water only **after** charging unless the electrolyte level is below the top of the plates. In this case, add just enough water to cover the plates, charge, and then check the level again. Never charge batteries if plates are exposed above electrolyte level. For best battery life, add only distilled water. **See following CAUTION.**

⚠ CAUTION

- **Do not overfill the batteries.**

NOTE: A battery watering gun or bottle (CC P/N AM10818) is available from your authorized Club Car dealer.

3. The battery hold-downs should be tight enough so that the batteries do not move while the vehicle is in motion, but not so tight as to crack or buckle the battery case. Tighten hold-down retaining nuts to 55 in·lb (6.2 N·m). The terminal connections should be clean and tight, and any worn insulation or frayed wires should be replaced. Tighten battery terminals to proper torque. **See Connecting the Batteries – Electric Vehicles on page 1-4.** **See following WARNING.**

⚠ WARNING

- **If battery wire terminals are damaged or corroded, replace or clean them as necessary. Failure to do so can cause them to overheat during operation and can result in fire, property damage, or personal injury.**

4. After use, charge the batteries. The batteries should never be left discharged any longer than absolutely necessary (do not leave discharged overnight).

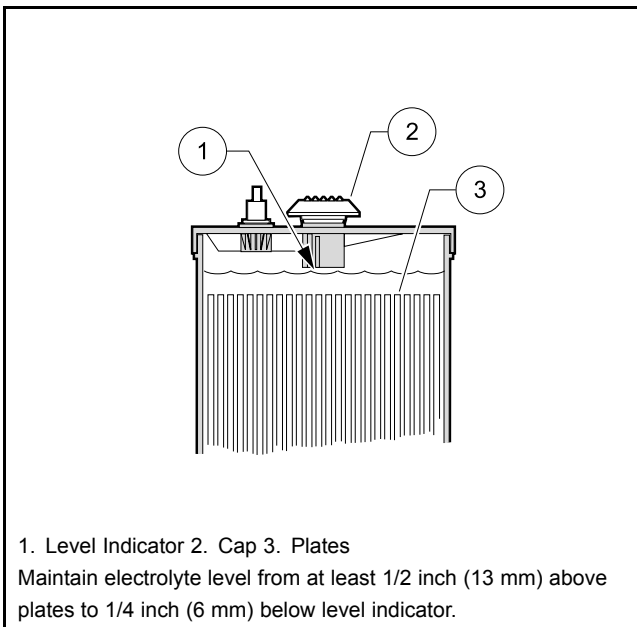

17

Figure 14-3 Electric Battery Electrolyte Level

SELF-DISCHARGE

Contaminants on dirty batteries can provide a path for a small current draw that can slowly discharge batteries, thus wasting valuable energy. To prevent self-discharge, batteries should always be kept clean.

Hot weather also has an effect on a battery's self-discharge rate. The higher the temperature, the quicker a set of batteries will discharge. In hotter climates, batteries should be checked more often. When storing batteries, keep in a cool place. **See Battery Storage on page 14-13.**

ELECTROLYTE LEVEL

⚠ CAUTION

- **Do not allow battery acid from battery caps or hydrometer to drip onto the front or rear body of the vehicle. Battery acid will cause permanent damage. Wash immediately.**

Add water only after charging unless the electrolyte is below the level of the plates. If the electrolyte level is below the level of the plates, add just enough water to cover the plates and then charge the batteries. After charging, fill with water to the level indicator. Filling a battery to the level indicator before charging will result in overfilling because the electrolyte level will rise during charging and some of the electrolyte may bubble out of the cap. This reduces the battery's capacity and corrodes the metal parts around it.

The electrolyte level should be checked weekly to be sure electrolyte is at its proper level (**Figure 14-3, Page 14-10**). Never allow the electrolyte level to fall below the tops of the plates because this will cause the exposed part of the plate to become permanently inactive. For best results, use a battery watering gun to add water to batteries. Check the electrolyte level more frequently in hot weather or when batteries are old.

VIBRATION DAMAGE

The battery hold-downs should always be tight enough to keep the battery from bouncing. Battery life may be severely shortened if the battery hold-downs are too loose. **See step 6. of Battery Replacement on page 14-5.** Excessive vibration causes the plates to shed prematurely and shortens the life of the battery. It may also cause acid to leak out of the vent caps and corrosion to build up on surrounding metal parts. The acid which is lost reduces the capacity of the battery and cannot be replaced. Battery hold-downs should NOT be so tight as to crack or buckle the battery case. This may cause leaks which would dry out a cell or cause internal short circuits. **See Battery Replacement on page 14-5.**

SINGLE POINT WATERING SYSTEM (SPWS)

▲ WARNING

- When replacing batteries in the Single Point Watering System, place the battery cap from the new replacement battery onto the used battery being removed from the car. Important safety warnings on the battery cap must remain with the battery after it has been removed from the car

CAUTION

- Water the batteries only **AFTER** charging.
- Use water that meets the quality standards shown on page 14-6. Maximize battery life by removing ions and heavy metals from water with the use of a single point watering system deionizer. A deionizer for vehicles with SPWS, Club Car Part Number 105166801 is available from Service Parts (DC powered water quality indicator light). Replacement cartridge: 104005901. Bottled distilled water, with hand pump, Club Car Part Number 104006101, is recommended for private consumer applications.

INITIAL MAINTENANCE OF THE SPWS

After six weeks of operation, remove the valves from the batteries and manually check the battery water level to ensure that the SPWS is not leaving any cells dry. This initial electrolyte level check on all the battery cells verifies that all the valves in the SPWS are functioning correctly. If a valve fails to open, the cell will eventually dry out. The initial one-time inspection of all cells will identify any occurrence of a valve that fails to open. If a valve fails to close, it will become evident due to the cell overflowing during routine watering. Either failure scenario is rare, but should be monitored in the initial inspection and during routine watering sessions. Replace malfunctioning valves to ensure maximum battery life.

After the initial six-week inspection, manually check the battery water levels at least once per year, particularly after winter storage or any other period of vehicle inactivity. **See following NOTE.**

NOTE: For the longest battery life, be sure the mineral contents of the water meet the minimum requirements as stated in the vehicle's appropriate maintenance and service manual. **See Battery Care on page 14-6.**

WATERING BATTERIES WITH THE SPWS

Checking the Water Flow Rate

1. Connect the water hose with the built-in screen filter (2) to the water faucet (1) (**Figure 14-4**). **See following CAUTION.**

CAUTION

- Make sure the screen filter is clean.

- Do not use a longer garden hose than provided with the System (20 feet or 6 meters), as a decrease in water pressure can overflow the batteries and damage the refill system.
2. Before screwing the hose-end assembly (3) onto the opposite end of the water hose, check the screen filter (4) inside the end of the assembly to make sure it is clean (**Figure 14-4**).
 3. Connect the purger (5) to the female coupler (8) on the end of the hose-end assembly (**Figure 14-5**).

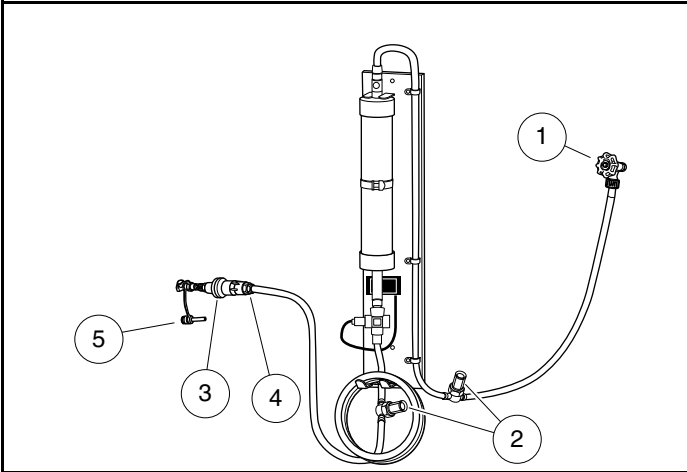

3083

Figure 14-4 Connecting Hose with Filter to Water Source

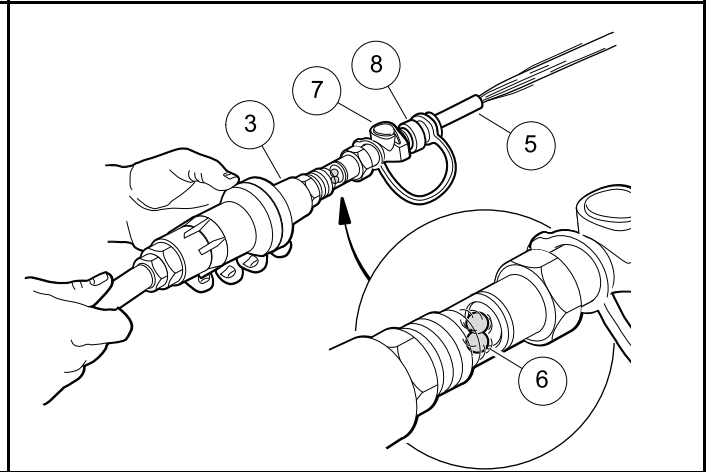

69

Figure 14-5 Checking the Water Flow Rate

4. Completely open the water faucet until the water flows out of the hose-end assembly (3), and note the movement of the red flow indicator balls (6). **See following NOTE.**

NOTE: This step also eliminates any trapped air from the water hose.

The water flow rate must be at least 2 gallons per minute (7.6 L per minute) and the water pressure must be no more than 100 psig (689.5 kPa) when static (no flow) for the SPWS to function properly.

5. Check the water quality light on the deionizer to make sure the light is green in color, indicating acceptable water quality. If the light indicates unacceptable water quality, the cartridge must be replaced.
6. After ensuring adequate water flow rate and water quality, press the grey button (7) on the end of the female coupler (8) to disconnect the purger from the pressure regulator.

Refilling the Batteries

1. Locate the battery fill coupling (9) on the driver side of the battery compartment, remove the dust cover (10) from the male connector (**Figure 14-6**), and connect the hose-end assembly (3) (**Figure 14-7**). The water flow will begin immediately.

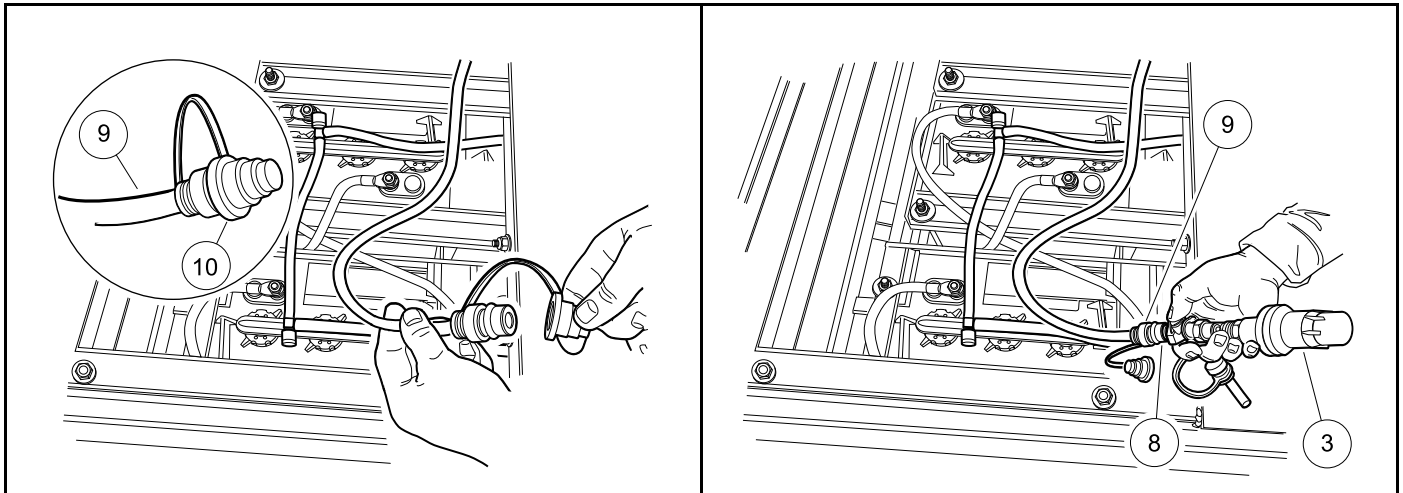

2829

Figure 14-6 Dust Cap

2830

Figure 14-7 Connecting Hose-end Assembly to Battery Fill Connector

- The red flow indicator balls should swirl, indicating that the batteries are being filled. **See following CAUTION.**

CAUTION

- If at any time water overflows from the batteries, immediately stop the refill process, disconnect the pressure regulator from the battery fill coupling, and call for service.
- When the red flow indicator balls stop moving, immediately press the grey button to disconnect the hose-end assembly from the battery fill coupling (9), and squeeze the dust cover (10) to lightly secure it to the male connector of the battery fill coupling (Figure 14-6).
 - Place the battery fill coupling into the space between the batteries and the car body. Leaving the fill coupling on top of the battery bank or tucked between the batteries can result in coupling damage.
 - Turn the water faucet off when finished filling the vehicle(s).

BATTERY STORAGE

See Storage – Electric Vehicles, Section 3, Page 3-2.

FLEET ROTATION

Rotate vehicle usage. It is very hard on batteries if the last vehicles in at night are the first ones out in the morning. Spread the workload evenly, giving all vehicles the same amount of use. This will keep your fleet in balance and will not overwork certain sets of batteries. **See following NOTE.**

NOTE: When vehicles are being rotated, the CDT (Controller Diagnostic Tool) can be a very helpful service tool. Monitoring the value of the Odometer or Amp-Hours with the CDT simplifies vehicle usage scheduling. See **Monitor Menu, Section 11, Page 11-10.**

DEEP-DISCHARGE

Never discharge batteries to the point the vehicle will no longer operate. This will considerably shorten the cycle life of the batteries, and may permanently damage the batteries. It is possible the batteries will not accept a charge if they are completely discharged. The deeper the discharge, the harder it is on the batteries. For this reason, it is recommended that electric vehicle batteries be charged after each use (provided the charge cycle will not be interrupted and the charger will be allowed to shut off automatically). Placing the batteries on charge after each use reduces the depth of discharge and prolongs battery life.

EARLY EXCESSIVE DISCHARGING

When vehicle batteries are new, they do not reach their full capacity until they have been discharged and recharged 50 to 70 times. If they are excessively discharged early in their life, their effective service life will be shortened. It is advisable to limit the use of any vehicle with new batteries for at least the first four weeks and then gradually increase their range.

⚠ DANGER

- See General Warnings on page 1-1.

⚠ WARNING

- See General Warnings on page 1-1.

GENERAL INFORMATION

This section includes information pertaining to servicing the QuiQ™ high frequency battery charger. Do not attempt to service a battery charger that has not been properly identified. If a charger cannot be properly identified, contact your local authorized Club Car dealer or distributor.

The High Frequency Battery Charger functions as an integral part of the vehicles' electrical system and will not work with other electric vehicles. The charger is programmed with a specific charge algorithm that is appropriate to the specific battery type used in the vehicle. **See Battery Charger Algorithms on page 15-2.**

The charger utilizes sophisticated charge termination criterion to shut off automatically, preventing the possibility of either undercharging or overcharging. The charger accomplishes this by monitoring battery Voltage, charge current, charge time and using strict dV/dt termination criterion.

FEATURES

Charge Interlock

When the AC power cord is inserted into a wall receptacle, the charger locks out the vehicle drive system. This prevents the possibility of driving the vehicle while the charger is plugged in and potentially damaging the vehicle and charger.

Long-Term Storage Charge

This charger is designed to be left connected to AC power during off-season or long-term storage. Be sure to check the charger monthly to ensure the charger is operating correctly during storage. The charger will enter maintenance mode if supported by the charge algorithm or automatically activate if battery voltage drops less than 2.1 volts per cell (24 cells is 50.4 volts) or 30 days have elapsed. To return the vehicle to service, disconnect the AC cord from the wall outlet, wait 15 seconds and then plug the AC cord back in. The charger will activate. Allow the vehicle to complete one full charge cycle before putting it into service.

UL AND CSA LISTING

When operated on a 120 volt / 60 Hz electrical system, this battery charger has been listed by Underwriters Laboratories and by the Canadian Underwriters (thereby meeting the criteria of the Canadian Standards Association).

CE COMPLIANCE

This battery charger is compliant with the EU EMC Directive 2004/108/EC.

IP (INGRESS PROTECTION) RATING

The enclosure of the charger has been tested successfully to EN60529, meeting IP66. The AC supply inlet is rated to IP20, which is suitable for indoor use only. Keep all AC connections clean and dry.

HOW TO IDENTIFY CHARGE ALGORITHM NUMBER

The algorithm numbers offered can be found in **See Battery Charger Algorithms on page 15-2**. The charger can display its algorithm number by initiating Algorithm Display Mode. To enter Algorithm Display Mode, do the following:

1. Disconnect the AC cord from the power outlet.
2. Disconnect the DC connector from the battery charger.
3. Wait for 1 to 1.5 minutes.
4. Connect the AC cord into the power outlet.
 - 4.1. All of the charger lights will turn on and then off.
 - 4.2. The AC on symbol will turn on.
 - 4.3. The current algorithm will display for 11 seconds.

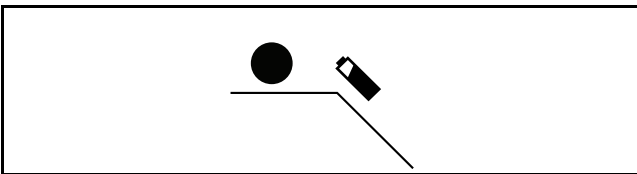

2388B

Figure 15-1 80% Charge Light

5. If the 80% charge light flashes, the current algorithm is 72 (**Figure 15-1**).

NOTE: The 80% charge light will flash 7 times, pause, then flash 2 times.

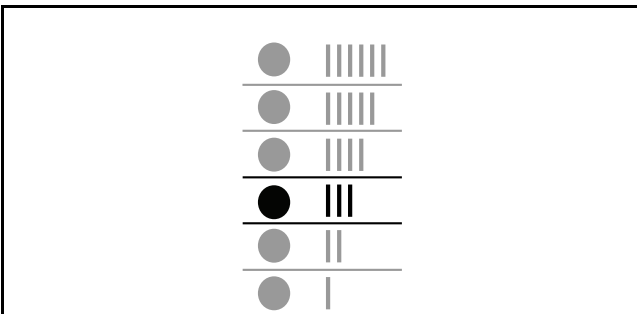

2387B

Figure 15-2 Number 3 Light

6. If the number 3 light flashes, the current algorithm is 3 (**Figure 15-2**).
7. Disconnect the AC cord from the power outlet.
8. Connect the DC connector.

Battery Charger Algorithms

CHARGER MODEL (PART NUMBER)	ALGORITHM	BATTERY TYPE
912-4854-04	algorithm # 72	JCI
912-4854-04	algorithm # 3	Trojan

HOW TO CHANGE THE ALGORITHM

1. Set the Run/Tow switch to TOW.
2. If equipped, disconnect the DC/DC converter connector.
3. Disconnect the AC cord.
4. Disconnect the main positive (+) battery wire.
5. Wait for 1 to 1.5 minutes.
6. Connect the AC cord.
7. While the battery charger lights flash, touch the main positive (+) battery wire to the battery post.
- 7.1. After three seconds, the algorithm display will change to the next algorithm. Continue to touch the main positive (+) battery wire to the battery post until the batteries start to charge.
- 7.2. When the batteries start to charge, disconnect the main positive (+) battery wire.
8. Disconnect the AC cord.
9. Connect the main positive (+) battery wire.
10. If equipped, connect the DC/DC converter connector.
11. Set the Run/Tow switch to RUN.

THE CHARGE CIRCUIT

The charge circuit consists of the onboard charger, batteries and charger information light (**Figure 15-3, Page 15-3**).

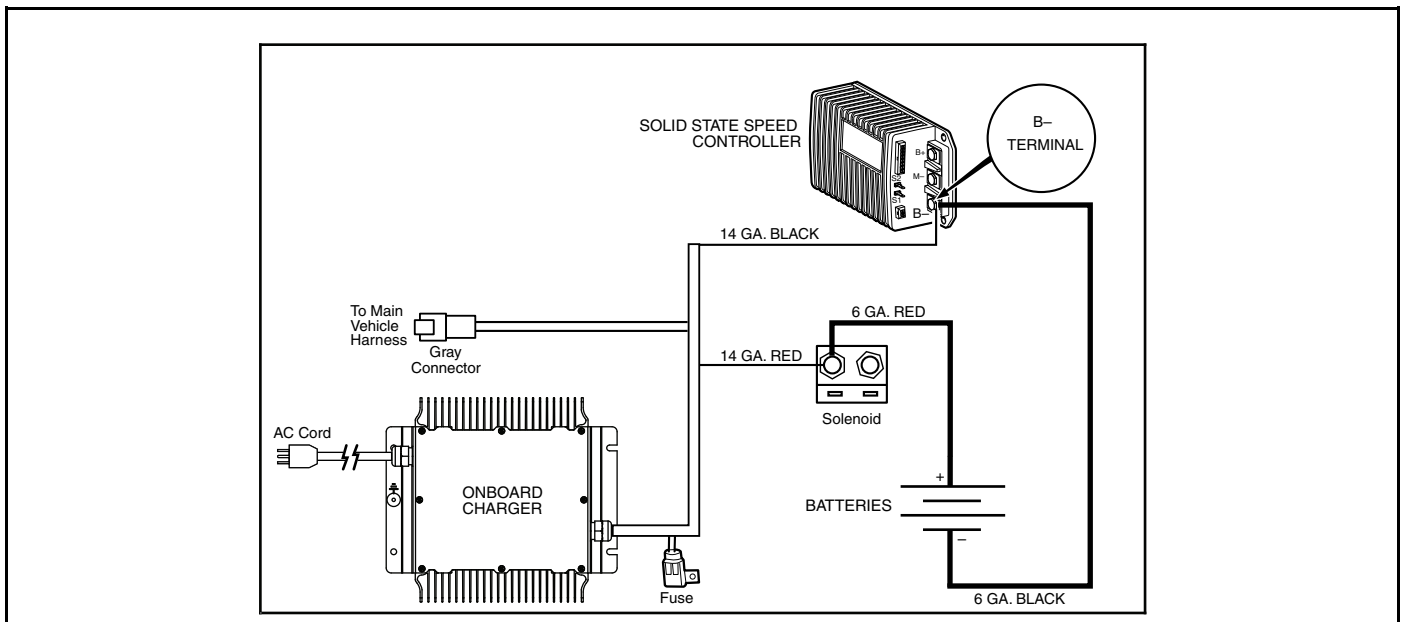

2979

Figure 15-3 Charge Circuit

ONBOARD CHARGER OPERATION

⚠ DANGER

- Battery – Explosive gases! Do not smoke. Keep sparks and flames away from the vehicle and service area. Ventilate when charging or operating vehicle in an enclosed area. Wear a full face shield and rubber gloves when working on or near batteries.
- The charging area must be ventilated. Hydrogen level in the air must never exceed 2%. The total volume of air in the charging area must be changed five times per hour. Exhaust fans should be located at the highest point of the roof. Contact a local HVAC engineer.
- Do not charge the vehicle batteries with the vehicle covered or enclosed. Any enclosure or cover should be removed or unzipped and pulled back when batteries are being charged. An accumulation of hydrogen gas could result in an explosion.
- Risk of electric shock. Connect charger power cord to an outlet that has been properly installed and grounded in accordance with all local codes and ordinances. A grounded outlet is required to reduce risk of electric shock; do not use ground adapters or modify plug.
- Do not touch uninsulated portion of output connector or uninsulated battery terminals.
- Disconnect the AC supply before making or breaking the connections to the battery.
- Do not open or disassemble charger.
- Do not operate this charger if the AC supply cord is damaged or if the charger has received a sharp blow, been dropped, or otherwise damaged in any way. Refer all repair work to the manufacturer or qualified personnel.
- This appliance is not intended for use by persons (including children) with reduced physical, sensory or mental capabilities, or lack of experience and knowledge, unless they have been given supervision or instruction concerning use of the appliance by a person responsible for their safety. Children should be supervised to ensure that they do not play with the appliance

⚠ WARNING

- The high frequency battery charger is programmed with an algorithm that matches the type and design specifications of the batteries originally installed in the vehicle. Never use this charger to charge batteries of a different type and design specification. Doing so will damage the non-matching batteries and greatly reduce their life span. If the batteries can not be replaced with the same as original, the charger must be replaced with one that matches the replacement batteries.
- Do not attempt to charge frozen batteries or batteries with bulged cases. Discard the battery in accordance with all environmental laws or return to an authorized Club Car dealer. Frozen batteries can explode.
- Only trained technicians should repair or service the charger. Contact your nearest Club Car distributor/dealer.
- Each charger should have its own dedicated 15 or 20 ampere separately protected (circuit breaker or fuse) single phase branch circuit, in accordance with all applicable electrical codes for the location.
- Connect the charger AC supply cord to a properly grounded, three-wire outlet of the proper Voltage and frequency as shown on the charger.

WARNING CONTINUED ON NEXT PAGE

 WARNING

- Do not use an adapter to plug the charger with a three-prong plug into a two-prong outlet. Improper connection of the equipment-grounding conductor can result in a fire or an electrical shock.
- Use only an appropriately sized AC power cord. See AC Power Connection on page 15-8.
- Do not use near fuels, grain dust, solvents, thinners, or other flammables. Chargers can ignite flammable materials and vapors.
- Do not expose to rain or any liquid. Keep the charger dry.
- Prior to servicing the charger, disconnect the AC power supply cord from the wall outlet and remove the battery charger from the vehicle. See removal procedure in the appropriate maintenance and service manual.
- Do not use a battery charger if the cord or plug is damaged in any way. Replace worn or damaged parts immediately. Failure to heed this warning could result in a fire, property damage, severe personal injury, or death.
- Do not operate the charger if it has received a sharp blow, was dropped, or otherwise damaged in any way.
- Have worn, cut, or damaged power cords or wires replaced immediately.
- Install surge arrestors on incoming AC power lines. Surge arrestors will help protect electrical components in the charger and on the vehicle from all but direct or close lightning strikes
- Ensure battery connections are clean and properly tightened.
- Wear safety glasses or approved eye protection when servicing the vehicle or battery charger. Wear a full face shield and rubber gloves when working on or near batteries.
- Do not wear loose clothing or jewelry such as rings, watches, chains, etc., when servicing the vehicle or battery charger.
- Use insulated tools when working near batteries or electrical connections. Use extreme caution to avoid shorting of components or wiring.

CHARGER DISPLAYS

10-LED display on charger:

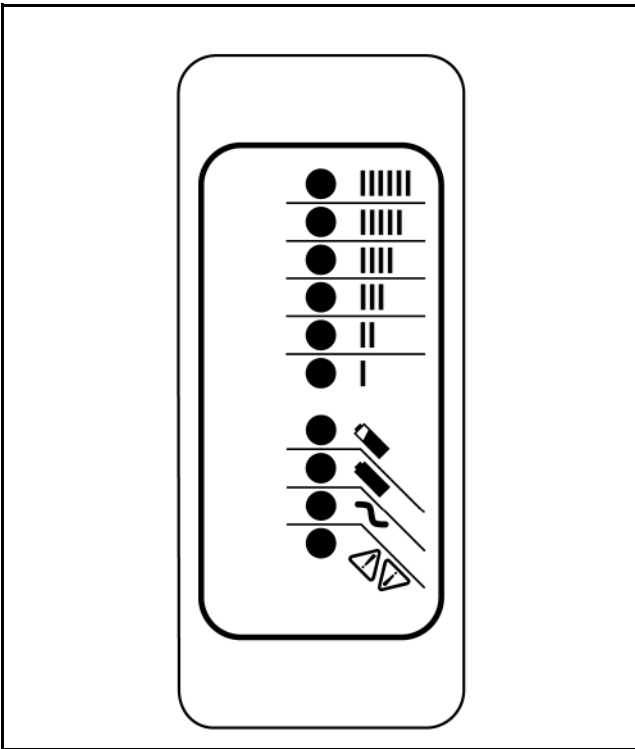



2379

Figure 15-4 10-LED Display on Charger

LED Color	Icon	Indication (following "Power-On Self Test")	STATUS EXPLANATION
Ammeter (Amber)		Solid:	Displays approximate scale of current output during bulk phase.
		Flashing:	High internal charger temperature. Output reduced. Also displays algorithm #1 through # 6 for 11 seconds if no battery is connected.
80% Charge (Amber)		Solid:	Bulk charge phase complete, 80% charged. In Absorption phase.
		Flashing:	<ol style="list-style-type: none"> 1. With no battery connecte, indicates algorithm # selected by number of flashes. 2. With battery connected, indicates battery being charged.

TABLE CONTINUED ON NEXT PAGE

100% Charge (Green)		Solid:	Charging is complete. Charger in Maintenance Mode.
		Flashing:	Absorption phase complete. In Finish phase
AC on (Amber)		Solid:	AC Power good
		Flashing:	Low AC Voltage. Check Voltage and power cord length (refer to guidelines) See AC Power Connection on page 15-8.
Fault (Red)		Flashing:	<ol style="list-style-type: none"> 1. Solid Red = Charger Hardware Failure; requires charger to be replaced 2. Flashing Red = Charge Cycle Caution; AC Voltage, DC Voltage, Ambient Temperature, Charge Cycle Timers

AC POWER CONNECTION

CAUTION

- **Charger enclosure may be hot during charging. Use hand protection if handling the charger while charging.**

NOTE: Make sure that the AC cord provided with your charger has the proper AC plug for your location. If it does not, contact your Club Car representative to obtain the proper cord or plug.

Only use one charger on a single 15 amp circuit or the circuit may become overloaded.

To reduce the risk of electric shock, the battery charger must be grounded. The charger is equipped with an AC electric cord with an equipment-grounding conductor and a grounding type plug. The AC plug must be connected to an appropriate receptacle that is properly installed and grounded in accordance with the National Electric Code and all local codes and ordinances.

The AC power cord must be a three-conductor, no. 12 AWG (American Wire Gauge) or no. 14 SWG (British Standard Wire Gauge), heavy-duty cord with ground, properly wired and in good electrical condition. Keep it as short as possible (no more than 12 feet (3.7 m)). Place all cords so they will not be stepped on, tripped over, or otherwise subject to damage or stress.

CHARGING BATTERIES

NOTE: Batteries should be put on charge even if they have been used for only a short time, i.e., 10 minutes. The charger is automatic and will turn off when batteries are fully charged. If the charger does not seem to be operating properly, or if the batteries seem weak, contact a local Club Car distributor/ dealer.

New batteries will not deliver their full range until the vehicle has been driven and recharged from 20 to 50 times.

Vehicles should be restricted to 40 to 50 amp hours of discharge between charges until the batteries have been properly seasoned (20 to 50 charge cycles). For maximum battery life, Club Car recommends that electric vehicles always be recharged after 40 to 50 amp hours of discharge or each night in order to avoid deep discharging the batteries. Charging between uses will also extend battery life.

When temperatures fall below 65 °F (18.3 °C), batteries charged in unheated areas should be placed on charge as soon as possible after use. Batteries are warmest immediately after use, while cold batteries require more time to fully charge.

1. Insert the onboard charger AC plug into a dedicated and properly wired AC receptacle to begin a charge cycle. **See Battery Charger Algorithms, Section 15, Page 15-2.**

NOTE: Only connect ONE charger to a single 15 amp circuit or the circuit may become overloaded.

2. Place the charger AC cord so it will not be stepped on, tripped over, or otherwise subject to damage or stress.
3. Do not place items in the compartment where the battery charger is installed. Provide the charger with adequate ventilation.

After the charger is plugged in, the vehicle's control circuit is locked out, preventing operation of the vehicle, as well as the possibility of subsequent damage to the charger and vehicle.

Once the lockout is actuated, the charger turns on and performs a Power-On Self Test in which the LED lights on the charger flash ON in sequence, the Charger Indicator Light on the dash will flash three times and the reverse buzzer will simultaneously sound three times. If test is successful, charging will start and the ammeter will come on.

The charger monitors battery voltage, charge current and charge time to determine when the batteries are properly charged. The charger will shut off by itself and the green battery icon will stop flashing and remain on.

The vehicle's control circuit lockout remains activated until the charger AC plug is disconnected from the AC receptacle.

MAINTENANCE

See General Warnings on page 1-1.

To ensure trouble-free performance, it is very important to follow an established preventive maintenance program. Regular and consistent maintenance can prevent vehicle downtime and expensive repairs that can result from neglect. Any charger not functioning correctly should be removed from use until it is properly repaired. This will prevent further damage to the vehicle and avoid the possibility of injury due to unsafe conditions. Contact your local Club Car distributor/dealer to perform all repairs and semiannual and annual periodic service

⚠ WARNING

- **If any problems are found during scheduled inspection or service, do not operate the vehicle until repairs are made. Failure to make necessary repairs could result in fire, property damage, severe personal injury, or death.**
- **Do not wear loose clothing or jewelry, such as rings, watches, chains, etc., when servicing the charger.**
- Do not expose charger to oil, dirt, mud or direct heavy water spray when cleaning vehicle.
- Keep all AC connections clean and dry.
- If the detachable input power supply cord set is damaged, replace with a cord that meets the following criteria:

For North America:	UL or CSA listed/approved detachable cord, 3 conductor, 16AWG minimum, and rated SJT; terminating in a grounding type IEC 60320 C14 plug rated 250V, 13A minimum.
For all other countries:	Safety approved detachable cord, 3 conductor, 1.5mm ² ; minimum, rated appropriately for industrial use. The cord set must be terminated on one end with a grounding type input connector appropriate for use in the country of destination and, on the other end, an output grounding type IEC 60320 C14 plug.

TROUBLESHOOTING

See General Warnings on page 1-1.

⚠ DANGER







- Do not touch any wire or component in the battery charger while AC power is present. Failure to heed this warning will result in an electric shock.

⚠ WARNING

- Knowledge of battery charger wiring and component terminology is required before attempting any repair (Figure 15-2, Page 15-3).
- Prior to servicing the charger, disconnect the AC power supply cord from the wall outlet and remove the battery charger from the vehicle. See Onboard Charger Removal And Installation on page 15-12.

If a fault occurs, count the number of red flashes (on the charger or dash) between pauses and refer to the table below:

HIGH FREQUENCY BATTERY CHARGER TROUBLESHOOTING GUIDE

RED FLASHES	CAUSE	SOLUTION
	Battery High Voltage	Ensure battery set is rated 48 volts and composed of 24 cells. See Battery Voltage Using Multimeter on page 15-11. If not, replace with correct battery set. Reset charger (interrupt AC power for 15 seconds).
	Battery Low Voltage	Ensure battery set is rated 48 volts and composed of 24 cells. Also, check the voltage of each individual battery. See Battery Voltage Using Multimeter on page 15-11. If not, replace with correct battery set. Reset charger (interrupt AC power for 15 seconds).
	Charge Timeout caused by battery pack not reaching required voltage. Charger output was reduced due to high temperatures	Check for loose or corroded connections. Check for old or defective batteries. See Test Procedures on page 15-11. Operate charger at a lower ambient temperature.
	Check Battery: battery could not be trickle charged up to minimum voltage	Check for shorted or damaged cells. See Battery Voltage Using Multimeter on page 15-11.
	Over-Temperature: Charger shut down due to high internal temperature	Check for dirty, obstructed, or damaged cooling fins. Clean if necessary and ensure sufficient cooling air flow. Reset charger (interrupt AC power for 15 seconds).
	Charger Internal Fault	Reset charger (interrupt AC power for 15 seconds). Return to qualified service depot if fault persists.

TEST PROCEDURES

See General Warnings, Section 1, Page 1-1.

Index of Test Procedures

- 1 – Battery Voltage Using Multimeter
- 2 – Battery Condition Using Charger – All Batteries
- 3 – On-Charge Battery Voltage Using Charger And Multimeter
- 4 – AC Power and Continuity Test of AC Circuit
- 5 – Charger DC Circuit Continuity Test

TEST PROCEDURE 1 – Battery Voltage Using Multimeter

See General Warnings on page 1-1.

1. Check battery pack voltage. **See Measuring Voltage of Battery Set, Section 14, Page 14-2.**
2. Normal no-load voltage should be between 50 and 52 volts for a fully charged battery set. Normal no-load voltage of an individual battery should not be less than 0.5 volts of the other 7 batteries (for 8 x 6 volt battery set).

TEST PROCEDURE 2 – Battery Condition Using Charger – All Batteries

The easiest way to monitor the condition of a vehicle's batteries is simply to observe the charger display (usually found on the dash) at the end of the charge cycle. After a full charge, disconnect the charger AC plug, wait 30 seconds and reconnect the charger AC plug. The green battery icon will flash quickly and then flash slowly within 10 to 20 minutes, indicating sound, fully charged batteries.

NOTE: Batteries near the end of their useful lives may not allow the battery charge current to taper and the green battery icon will continue to flash quickly. **See Batteries: IQ Plus Electric Vehicles on page 14-1.**

Continued poor performance may indicate a problem in the vehicle electrical system, brakes or battery charger. If the problem is not found in the vehicle or charging system, proceed to the on-charge voltage test. If the green battery icon does not change to a slow flash, the batteries should be tested further using the on-charge voltage test.

TEST PROCEDURE 3 – On-Charge Battery Voltage Using Charger And Multimeter

When the batteries are fully charged, disconnect the charger DC plug. Wait 20 to 30 seconds and reconnect the DC plug to restart the charger. After 5 minutes, use a multimeter to check and record the voltage of the battery set as well as the individual batteries. Set the multimeter to 200 volts DC. Place the red (+) probe on the positive (+) post of battery no. 1 and the black (-) probe on the negative (-) post of battery no. 8 (for 8 x 6 volt battery set). Record reading. Then set multimeter to 20 volts DC and place the red (+) probe on the positive (+) post and the black (-) probe at the negative (-) post of each battery. Record the readings.

The on-charge voltage for the set should be between 56.0 volts and 63.0 volts depending on the age and state of charge of the batteries being tested.

For 6 volt batteries: If individual batteries read above 7.0 volts and are within 0.5 volt of each other, go to the hydrometer test or discharge test. **See Battery Testing – 6 Volt, Section 14, Page 14-3.** If any battery reads below 7.0 volts and not within 0.5 volts of those batteries above 7.0 volts, replace battery. If readings are below 7.0 volts but within 0.5 volts of each other, the batteries are old.

TEST PROCEDURE 4 – AC Power and Continuity Test of AC Circuit

1. Disconnect AC cord from the wall outlet and DC plug from the vehicle receptacle.
2. Check the AC line fuse or circuit breaker in the storage facility.
3. With a multimeter set to 500 volts AC, check incoming AC voltage. Insert multimeter test probes into AC wall outlet; voltage should be between 85 and 270 volts. **See QuiQ Battery Charger Specifications, Section 2, Page 2-3.** If proper voltage is not present, have building wiring checked by a licensed electrical contractor.
4. If the charger will not power ON, check AC cord connections.
5. If the charger is connected correctly, check continuity of the AC cord wires.

TEST PROCEDURE 5 – Charger DC Circuit Continuity Test

1. Disconnect the AC cord from the wall outlet and the DC cord plug from the charger lead.
2. Check continuity of the DC cord wires from plug pin to large solenoid post (10-gauge red wire) and B- terminal of controller (10-gauge black wire). **See following NOTE.**

NOTE: The 10-gauge red wire from the charger to the solenoid has an in-line 30-amp fuse.

3. When finished, connect DC cord plug to the charger lead.

CHARGER REPAIRS

See General Warnings on page 1-1.

NOTE: The high frequency charger offers no replacement parts. If necessary, the charger must be replaced. See **Onboard Charger Removal And Installation on page 15-12.**

ONBOARD CHARGER REMOVAL AND INSTALLATION

See General Warnings on page 1-1.

WARNING

- Knowledge of battery charger wiring and component terminology is required before attempting any repair See Troubleshooting on page 15-10.
- Prior to servicing the charger, disconnect the AC power supply cord from the wall outlet and remove the battery charger from the vehicle.

ONBOARD CHARGER REMOVAL

1. Disconnect the batteries and discharge the controller. **See Disconnecting the Batteries – Electric Vehicles, Section 1, Page 1-4.**
 2. Remove the wire ties securing the connector to the charger P-clip.
 3. Disconnect the all connectors from the charger AC and DC connector.
 4. Remove four lock nuts (5) securing charger to charger mounting plate.
-

5. Remove charger from vehicle.

ONBOARD CHARGER INSTALLATION

1. Install charger onto vehicle.
2. Install the four lock nuts (5) securing charger to charger mounting plate. Tighten to 40 in·lb (5.4 N·m).
3. Connect the AC and DC connector.
4. Connect 8-pin grey connector.
5. Install wire ties to secure connectors to the charger P-clip.
6. Connect the batteries. **See Connecting the Batteries – Electric Vehicles on page 1-4.**

Pagination Page

⚠ DANGER

- See General Warnings on page 1-1.

⚠ WARNING

- See General Warnings on page 1-1.

GENERAL INFORMATION

The IQ Plus vehicle is equipped with a 48-volt DC, shunt-wound, reversible traction motor. This 3.7 horsepower motor is designed for use on IQ Plus vehicles only. Club Car recommends that motors requiring major repair be sent to a qualified motor repair shop; however, there are many relatively simple tasks that can be performed by a technician with general knowledge and experience in electric motor repair.

EXTERNAL MOTOR TESTING

The following tests can be performed without disassembling the motor using a multimeter or continuity tester.

NOTE: Tag the motor wires for identification before disconnecting.

Index of Test Procedures

- 1 – Internal Short Circuits
- 2 – Armature Circuit Open
- 3 – Field Circuit Open

TEST PROCEDURE 1 – Internal Short Circuits

See General Warnings on page 1-1.

1. Disconnect the batteries and discharge the controller. **See Disconnecting the Batteries – Electric Vehicles, Section 1, Page 1-4.**
2. Disconnect wires from terminals on motor using two wrenches to prevent posts from turning.
3. With a multimeter set to 200 ohms, place black (–) probe on motor housing. Scratch through paint to ensure a good connection. Place red (+) probe on A1, A2, F1, and F2 terminals respectively. Multimeter should indicate no continuity. If readings are incorrect, motor will need to be removed from the vehicle and repaired by a qualified technician. **See Motor Removal on page 16-2.**
- 3.1. An incorrect reading from the A1 or A2 terminal indicates three possible problems: a grounded A1 or A2 terminal, a grounded wire in the brush area, or a grounded armature/commutator. An incorrect reading for the F1 or F2 terminal indicates a possible grounded F1 or F2 terminal or field coil.
4. Connect the batteries. **See Connecting the Batteries – Electric Vehicles, Section 1, Page 1-4.**

TEST PROCEDURE 2 – Armature Circuit Open

See General Warnings on page 1-1.

1. Disconnect the batteries and discharge the controller. **See Disconnecting the Batteries – Electric Vehicles, Section 1, Page 1-4.**
2. Disconnect wires from the A1 and A2 terminals on the motor using two wrenches to prevent posts from turning. Set a multimeter to 200 ohms and place the red (+) probe on the A1 terminal and black (–) probe on the A2 terminal. The multimeter should indicate continuity. If the reading is incorrect, a possible open or poor contact in a brush assembly and/or open armature windings may be the cause. The motor will need to be removed from the vehicle and repaired by a qualified technician. **See Motor Removal on page 16-2.**
3. Connect the batteries. **See Connecting the Batteries – Electric Vehicles, Section 1, Page 1-4.**

TEST PROCEDURE 3 – Field Circuit Open

See General Warnings on page 1-1.

1. Disconnect the batteries and discharge the controller. **See Disconnecting the Batteries – Electric Vehicles, Section 1, Page 1-4.**
2. Disconnect wires from the F1 and F2 terminals on the motor using two wrenches to prevent posts from turning. Set a multimeter to 200 ohms and place the red (+) probe on the F1 terminal and the black (–) probe on the F2 terminal. The multimeter should indicate continuity. If the reading is incorrect, a possible open field coil or bad connections at the terminals may be the cause. The motor will need to be removed from the vehicle and repaired by a qualified technician. **See Motor Removal on page 16-2.**
3. Connect the batteries. **See Connecting the Batteries – Electric Vehicles, Section 1, Page 1-4.**

MOTOR REMOVAL

See General Warnings on page 1-1.

1. Disconnect the batteries and discharge the controller. **See Disconnecting the Batteries – Electric Vehicles, Section 1, Page 1-4.**
2. Disconnect wires from the terminals on the motor using two wrenches to prevent posts from turning. Label the wires to ensure proper reconnection.
3. Slightly loosen all the lug nuts on both rear wheels.
4. Place floor jack under transaxle and raise rear of vehicle (**Figure 16-1, Page 16-3**) then place jack stands under frame crossmember between the spring mount and the side stringer, just forward of each rear wheel. Lower the vehicle to let the jack stands support the vehicle (**Figure 16-2, Page 16-3**). **See following WARNING.**

⚠ WARNING

- Lift only one end of the vehicle at a time. Use a suitable lifting device (chain hoist or hydraulic floor jack) with 1000 lb. (454 kg) minimum lifting capacity. Do not use lifting device to hold vehicle in raised position. Use approved jack stands of proper weight capacity to support the vehicle and chock the wheels that remain on the floor. When not performing a test or service procedure that requires movement of the wheels, lock the brakes.

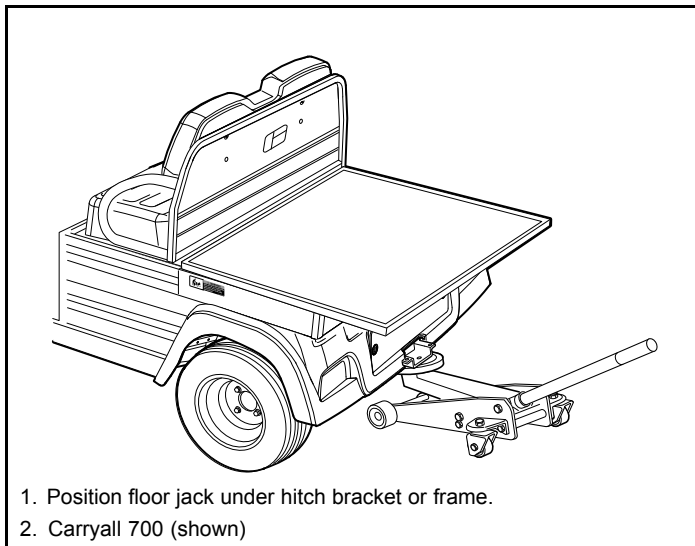

1. Position floor jack under hitch bracket or frame.
2. Carryall 700 (shown)

2867

Figure 16-1 Lift Vehicle with Floor Jack

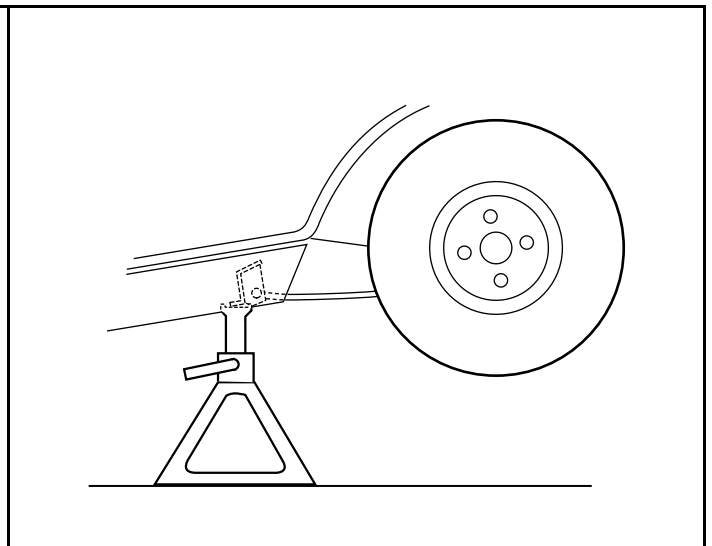

Figure 16-2 Vehicle Supported on Jack Stands

5. Remove both rear wheels.
6. Remove the nut, cup washer, and bushing from the bottom side of the shock absorber. Compress the shock absorber (pushing upwards) to move it out of the way (**Figure 16-3, Page 16-3**).
7. Remove the nuts and bolts mounting the rear leaf springs to the shackles.
8. To gain easier access to the motor, lower the transaxle as low as it will go. If more room is needed, remove the jack from beneath the transaxle and allow the springs to rest on the floor (**Figure 16-3, Page 16-3**).

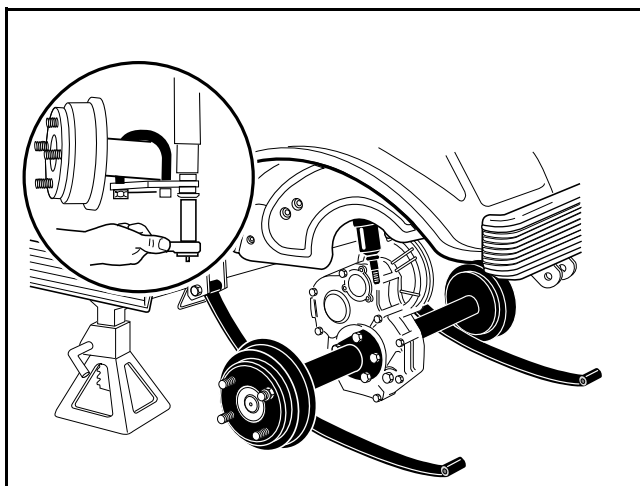

Figure 16-3 Lower Axle

9. Remove the four bolts that mount the motor to the transaxle (**Figure 16-21, Page 16-16**). See following **CAUTION**.

▲ CAUTION

- Do not position fingers under motor when sliding motor off of the input shaft in step 9. Fingers may get pinched when motor disengages.

10. Carefully slide the motor away from the transaxle until the motor spline disengages the input shaft and remove the motor from the vehicle.

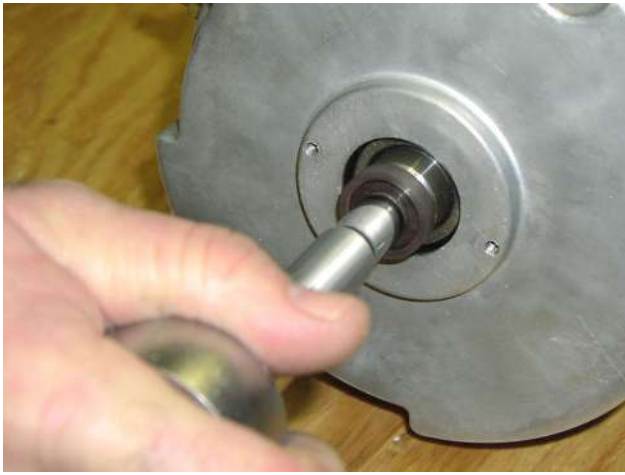

Figure 16-4 Speed Sensor Magnet

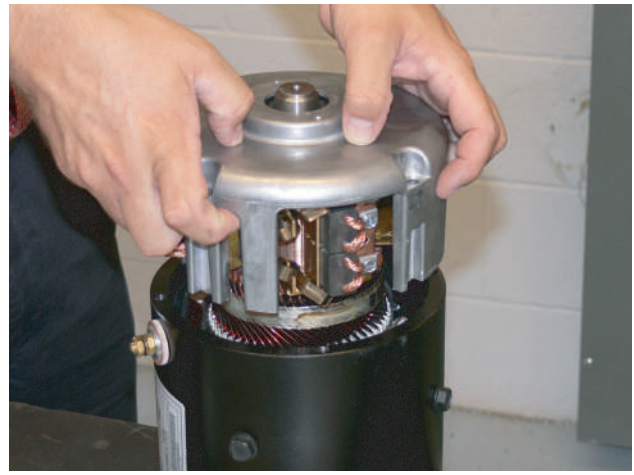

Figure 16-5 End Cap Removal

MOTOR DISASSEMBLY

1. Release the clasp and remove the headband assembly (21) from the motor. Visually inspect brushes and springs. **(Figure 16-13, Page 16-10).**
2. Before continuing disassembly, place match marks on the motor end cap (20) and motor frame (14).
3. Remove speed sensor (10) and magnet (12).
 - 3.1. Remove the two screws (11) and clamp that secure the speed sensor (10) to the end cap (20).
 - 3.2. Remove the bolt (13) securing the magnet (12) to the armature shaft (15). Hold the back of the armature assembly to keep it from turning as you remove the bolt.
 - 3.3. Inspect the speed sensor magnet. **See Speed Sensor Magnet Inspection on page 16-9.**

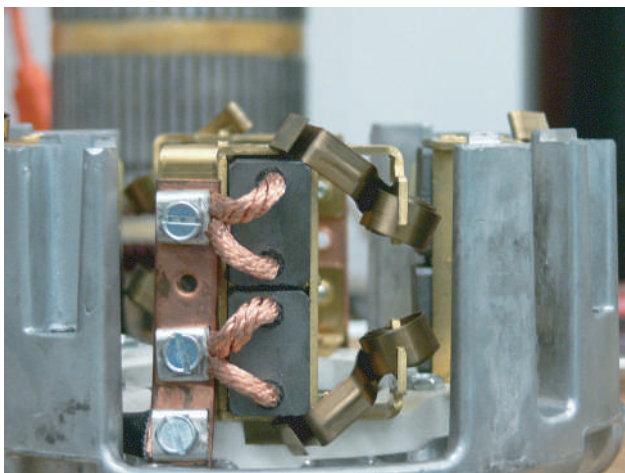

Figure 16-6 Brush Springs Positioning



Figure 16-7 Armature Removal

4. Orient the motor so that the splined end of the armature is facing down.

5. Remove the four end cap bolts. The weight of the motor housing will cause it to drop when the bolts are removed. **See following CAUTION.**

▲ CAUTION

- **The motor housing will drop when the bolts are removed. Do not put fingers under the motor housing when removing bolts.**

6. Remove the end cap and armature from the motor frame (**Figure 16-5, Page 16-4**).
7. Inspect the brush springs for proper tension. **See Motor Brush, Spring, and Terminal Insulator Inspection on page 16-8.**
8. Remove the armature from the end cap bearing. **See following CAUTION and NOTE.**

▲ CAUTION

- **Removing the armature from the end cap requires two people: one to operate the press, and another to hold the armature. Failure to heed this CAUTION could result in personal injury and/or damage to the armature resulting from an unsupported armature falling after it becomes disengaged from the end cap bearing.**

NOTE: *Replacement of the end cap bearing is recommended if the armature is removed.*

- 8.1. Position the brush springs to reduce tension during removal of the armature. (**Figure 16-6, Page 16-4**).
- 8.2. Place the end cap in a press with the armature facing down.
- 8.3. Place a bearing press tool with an outer diameter smaller than that of the armature shaft between the press ram and the armature shaft (**Figure 16-7, Page 16-4**).
- 8.4. Have an assistant support the armature while the press is activated.
9. Inspect the armature for wear and damage. **See Armature Inspection and Testing on page 16-7.**
10. Inspect the motor frame and field windings. **See Motor Frame and Field Windings Inspection on page 16-8.**
11. Remove the brush rigging.
 - 11.1. Mark the brush terminal posts (A1 and A2).
 - 11.2. Remove the two nuts securing the brush terminals (A1 and A2) to the end cap.
 - 11.3. Remove the four bolts and the brush rigging from the end cap (**Figure 16-8, Page 16-6**).
12. Inspect the terminal insulators. **See Terminal Insulator Inspection on page 16-9.**
13. Remove the bearing from the end cap.
 - 13.1. Remove the retaining ring that secures the bearing in the end cap (**Figure 16-9, Page 16-6**).
 - 13.2. Use an arbor press to remove the bearing from the end cap.
14. Inspect the bearing for wear and damage. **See Bearing Inspection on page 16-9.**

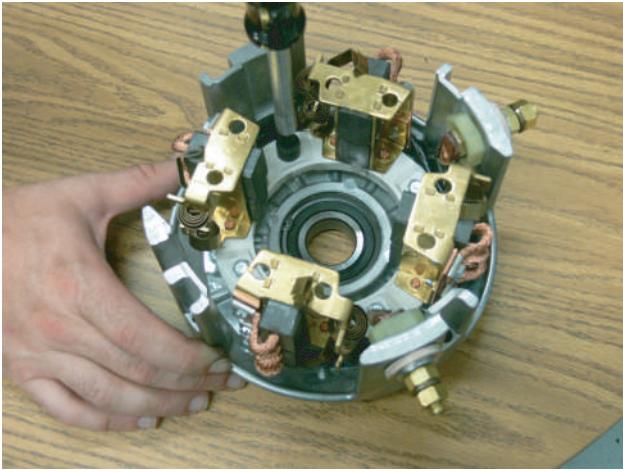

Figure 16-8 Brush Rigging Removal

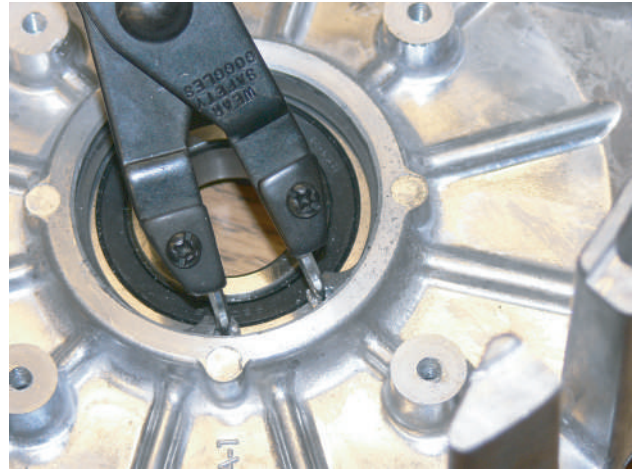

Figure 16-9 Retaining Ring Removal

MOTOR COMPONENT TESTING AND INSPECTION

See General Warnings on page 1-1.

ARMATURE INSPECTION AND TESTING

1. Remove the motor from the vehicle. **See Motor Removal, Section 16, Page 16-2.**
2. Remove the end cap and armature by performing steps 1 through 6 of Motor Disassembly on page 16-4.

Visual Inspection

- Burned, charred or cracked insulation
- Improperly cured varnish
- Thrown solder
- Flared armature windings
- Damaged armature core laminations
- Worn, burned or glazed commutators
- Dirty or oily commutators
- Raised commutator bars
- Worn armature bearing or shaft

A dirty or oily commutator should be cleaned and wiped dry. Abnormalities identified during the inspection can help determine original cause of failure. Slight roughness of the commutator can be polished smooth with 400 grit or finer sandpaper. **See following CAUTION and NOTE.**

CAUTION

- **Do not use emery cloth to polish the commutator. Particles of emery are conductive and may short-circuit the commutator bars. Do not use oil or lubricants on the commutator or brushes.**

NOTE: Oil on the commutator may indicate a faulty transaxle input shaft oil seal.

Armature Ground Test

CAUTION

- **Do not submerge the armature in solvent.**

NOTE: Before testing the armature, wipe it clean with a clean cloth. Remove any carbon dust and metal particles from between the commutator bars.

1. With a multimeter set to 200 ohms, place one probe on the commutator (1) and the other on the armature core (2). The multimeter should indicate no continuity (**Figure 16-10, Page 16-8**). If the reading is incorrect, replace the armature.

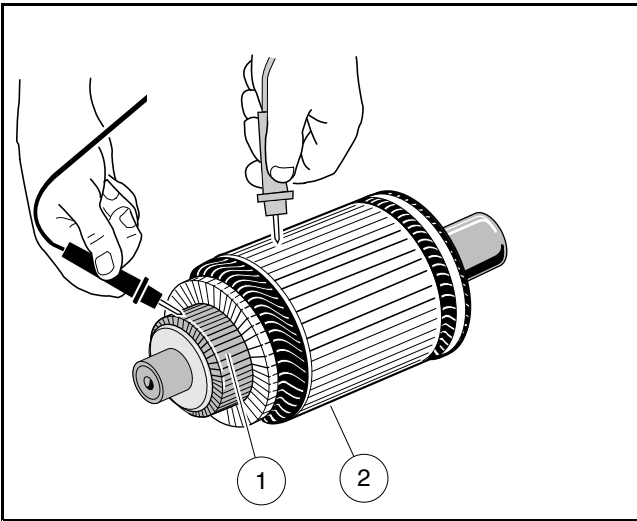

Figure 16-10 Armature Test

MOTOR FRAME AND FIELD WINDINGS INSPECTION

1. Remove the motor from the vehicle. **See Motor Removal, Section 16, Page 16-2.**
2. Remove the end cap and armature by performing steps 1 through 6 of Motor Disassembly on page 16-4.
3. Burned or scorched insulation on the field windings indicates the motor has overheated due to overloads or grounded or shorted coil windings. If the insulation on the field windings is scorched, replace the motor or the stator shell assembly.

MOTOR BRUSH, SPRING, AND TERMINAL INSULATOR INSPECTION

Brush Spring Tension Test

1. Remove the motor from the vehicle. **See Motor Removal, Section 16, Page 16-2.**
2. Release the clasp and remove the headband from the motor.
3. Inspect the brush springs (18) (**Figure 16-13, Page 16-10**). Replace springs that are discolored from heat (light gold or blue tinted).
4. Test the brush springs for proper tension.
 - 4.1. Place a C-shaped steel plate (1) on a scale (2).
 - 4.2. Place the end of the C-shaped plate (1) so that it is between the spring and the brush.
 - 4.3. Gently pull the scale (2) to obtain the spring tension reading. **See following CAUTION.**

CAUTION

- **When checking brush spring tension, do not over-extend the spring. Using excessive force will damage the spring.**
- 4.4. Replace springs which require a force of less than 35 ozf. (990 gf.) (**Figure 16-11, Page 16-9**). **See following NOTE.**

NOTE: When installing new brushes, remove and replace brushes one at a time. This method ensures the terminals and brushes will be properly positioned in the rigging. Refer to **Motor Assembly on page 16-11** for brush installation.

When replacing brushes, replace all four brushes. Never replace only two.

Install the brushes in the same rigging 180° apart from each other.

Brush Inspection

1. Remove the motor from the vehicle. **See Motor Removal, Section 16, Page 16-2.**
2. Release the clasp and remove the headband from the motor.
3. Inspect the brushes (16) for damage or excessive wear (**Figure 16-13, Page 16-10**). Replace brushes if required. **See preceding NOTE.**
4. Use dial calipers or a micrometer to measure the brush length. The minimum-allowable brush length is 0.62 inches (16 mm). Replace the set of brushes as required. **See preceding NOTE.**

Terminal Insulator Inspection

1. Remove the motor from the vehicle. **See Motor Removal, Section 16, Page 16-2.**
2. Remove the terminal insulators by performing steps 1 through 11 of Motor Disassembly on page 16-4.
3. Inspect the insulators for cracks or other damage. Replace insulators as required.

Bearing Inspection

NOTE: *Replacement of the end cap bearing is highly-recommended if the end cap is removed from the motor. The following procedure is provided as a guideline for determining general bearing failure.*

1. Remove the motor from the vehicle. **See Motor Removal, Section 16, Page 16-2.**
2. Remove the bearing by performing steps 1 through 13 of Motor Disassembly on page 16-4.
3. Use a clean cloth to wipe the carbon dust off of the bearing. Inspect the bearing by spinning it by hand and checking for both axial (A) and radial (B) play (**Figure 16-12, Page 16-9**).
4. Replace the bearing if it is noisy, does not spin smoothly, or has excessive play. Check the bearing and replace if rusted, worn, cracked, or if there is an abnormal color change in the metal of the bearing.

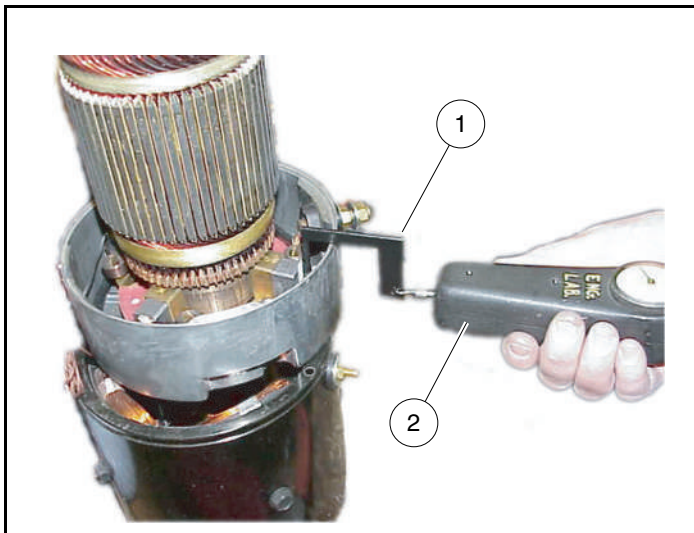

Figure 16-11 Brush Spring Tension Test

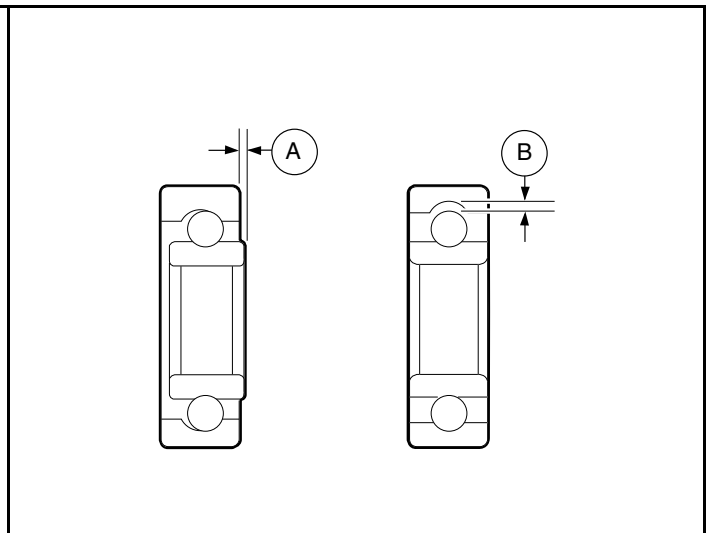

Figure 16-12 Bearing Inspection

Speed Sensor Magnet Inspection

Inspect the speed sensor magnet (12) for rust, wear, and cracks (**Figure 16-13, Page 16-10**). Replace the magnet if necessary.

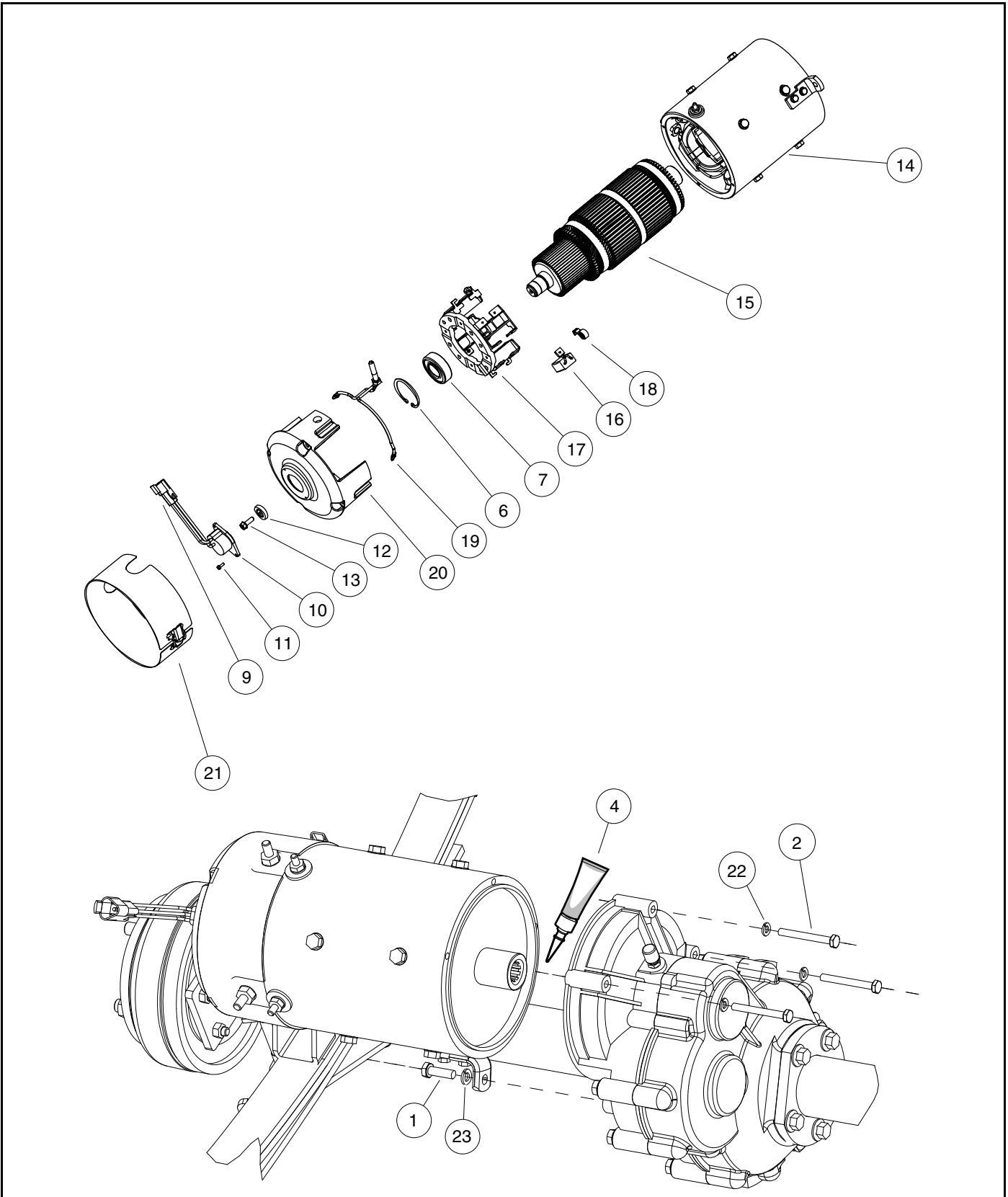

Figure 16-13 Motor

RECONDITIONING THE MOTOR

See General Warnings on page 1-1.

Motor reconditioning must be performed by a qualified motor repair technician. The use of proper tools and procedures is absolutely essential for successful motor reconditioning.

MOTOR SPECIFICATIONS

Any rework must be performed by a qualified technician. Motor service specifications are listed in the following table.

ITEM	SERVICE LIMIT
Commutator diameter (minimum)	2.80 in. (71.10 mm)
Commutator concentric with armature shaft within	0.003 in. (0.08 mm)
Bar to bar runout should not exceed	0.005 in. (0.013 mm)
Undercut of segment insulator after machining commutator	0.040 in. (1.0 mm)
Armature resistance at 75 °F (24 °C)	0.014 ohms between bars 1 and 15
Field resistance at 75 °F (24 °C)	0.55 ohms

MOTOR ASSEMBLY

See General Warnings on page 1-1.

1. Replace the bearing.
 - 1.1. Use an arbor press to install a new bearing into the end cap. To help avoid damaging the bearing, apply pressure only to the outer race when installing the bearing.
 - 1.2. Install the retaining ring to secure the bearing.
2. Install the brushes and brush rigging. **See following NOTE.**

NOTE: When installing new brushes, remove and replace brushes one at a time. This method ensures the terminals and brushes will be properly positioned in the rigging.

When replacing brushes, replace all eight brushes.

Install the brushes in the same rigging 180° apart from each other.

- 2.1. Insert the brushes into the brush rigging as shown.
- 2.2. Insert the two terminal posts through insulators in the end cap (20) wall at the A1 and A2 positions (**Figure 16-13, Page 16-10**).
- 2.3. Place external insulators and washers on each terminal post, and secure terminal with nuts. Tighten nuts to 100 in·lb (11.3 N·m). Ensure that the terminal posts do not rotate when tightening the nuts.
- 2.4. Secure the brush rigging to the end cap with four bolts. Tighten the bolts to 25 in·lb (2.8 N·m).
- 2.5. One at a time, push the brushes back until they are completely retracted into their mounting slots (**Figure 16-14, Page 16-12**).

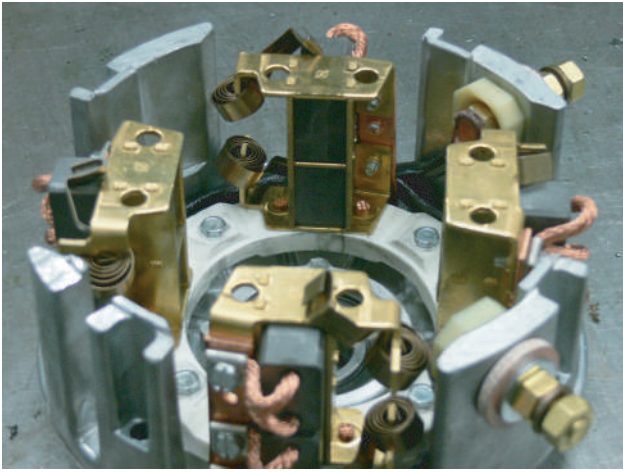

Figure 16-14 Retracted Brushes

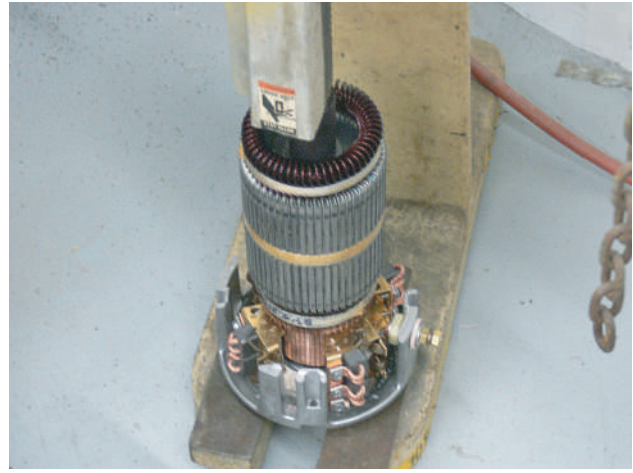
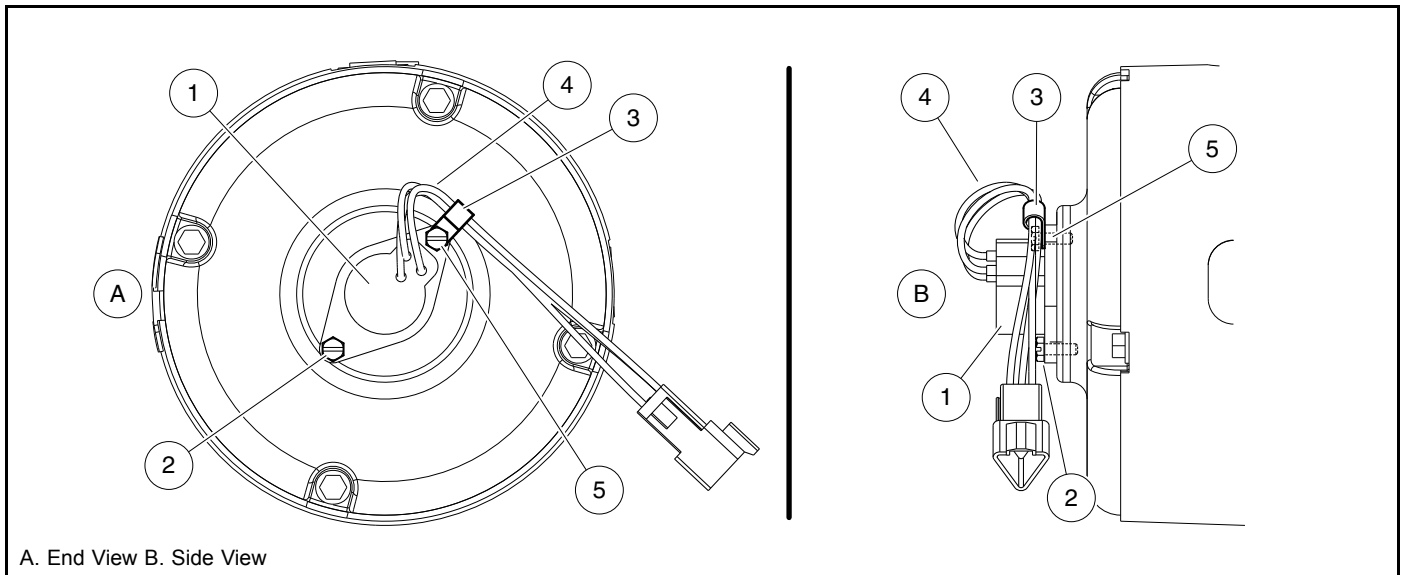

Figure 16-15 Armature Installation

3. With the brushes retracted, use an arbor press to press the armature shaft into the end cap bearing (**Figure 16-15, Page 16-12**). See following **CAUTION**.

CAUTION

- **Make sure the brushes are held back. Do not allow the brushes to support the weight of the commutator. The brushes can be easily damaged by this weight.**
4. Move the springs back to their original position. Ensure that the spring rests on the end of each brush.
 5. Align the match marks on the end cap (20) and the motor frame (14) and secure with four bolts (**Figure 16-13, Page 16-10**). Tighten bolts to 130 in·lb (14.7 N·m).
 6. Install the speed sensor magnet (12) with bolt (13). Tighten to 65 in·lb (7.3 N·m).
 7. Install the speed sensor (1) with one screw (2) finger-tight (**Figure 16-16, Page 16-13**).
 8. Install clamp (3) onto sensor wires (4) and secure with other screw (5) finger-tight. Ensure clamp (3) and wires (4) are oriented as shown (**Figure 16-16, Page 16-13**). Tighten both screws (2 and 5) to 20 in·lb (2.2 N·m).
 9. Make sure the armature turns freely. If it does not turn freely, disassemble the motor to find the problem.



A. End View B. Side View

3066

Figure 16-16 Speed Sensor Clamp

MOTOR INSTALLATION

See General Warnings on page 1-1.

1. Clean the transaxle input shaft.
 - 1.1. Spray the input shaft thoroughly with CRC® Brakleen™ or equivalent brake cleaner degreaser.
 - 1.2. Wipe input shaft with a clean cloth.
 - 1.3. Inspect the grooves of the input shaft and remove any remaining debris.
 - 1.4. Repeat steps 1.1 through 1.3 until input shaft is clean.
2. Lubricate the transaxle input shaft.
 - 2.1. Squeeze approximately 1/2 inch (1.3 cm) of moly-teflon lubricant (CCI P/N 102243403) from tube onto a putty knife as shown (Figure 16-17, Page 16-14).
 - 2.2. Rotate wheels to rotate input shaft.
 - 2.3. Apply motor coupling grease evenly to the rotating input shaft starting at approximately 1/8 inch (3.1 mm) from the end of the shaft and working back toward the transaxle (away from the end of the shaft) (Figure 16-18, Page 16-14).
 - 2.4. The grease should be evenly distributed in the grooves to a width of approximately 3/8 inch (9.5 mm).
 - 2.5. Use a flat screwdriver to clean the grease out of one of the grooves and allow air to escape when the motor is pushed onto the input shaft.

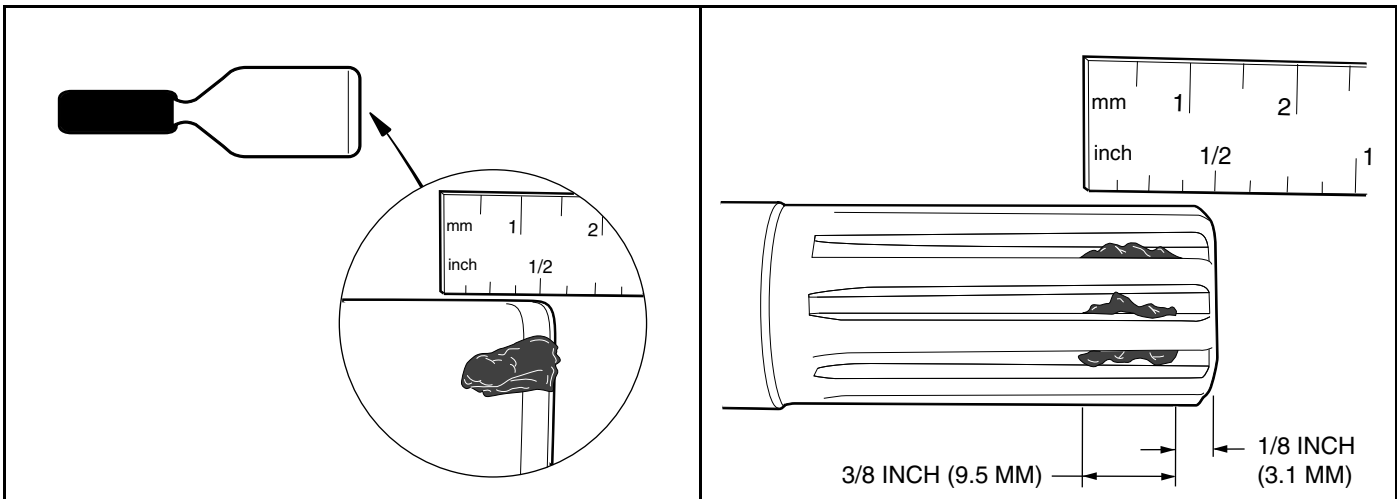

Figure 16-17 Grease on Putty Knife

Figure 16-18 Application of grease to Input Shaft Grooves

- 2.6. Check the chamfer (1) and end (2) of the input shaft to ensure these areas are completely clean of grease as shown (Figure 16-19, Page 16-15).
3. Install motor on transaxle.
 - 3.1. Slide the motor coupling onto the transaxle input shaft. **See following NOTE.**

NOTE: The coupling will push any excess grease on the input shaft along the shaft toward the transaxle.

When the motor is pushed onto the input shaft, the motor housing will not bottom out against the transaxle housing. There will be approximately 1/16 inch (1.6 mm) gap between the motor adapter ring and transaxle housing as shown (Figure 16-20, Page 16-15).

- 3.2. Loosely install the four bolts that secure the motor to the transaxle. Do not tighten.
- 3.3. Begin finger-tightening the bolts (1 and 2) in the sequence indicated (Figure 16-21, Page 16-16). Continue tightening by hand until the motor is seated in the transaxle housing. **See following CAUTION and NOTE.**

CAUTION

- **Make sure the motor is properly seated in the transaxle housing.**

NOTE: Failure to install and tighten the motor mounting bolts in the proper sequence and to the proper tightness may result in motor noise during operation.

- 3.4. Tighten the right bolt (1) to 65 in·lb (7.3 N·m) (Figure 16-21, Page 16-16).
- 3.5. Tighten the left bolt (2) to 65 in·lb (7.3 N·m) (Figure 16-21, Page 16-16).
- 3.6. Tighten the center bolt (3) to 65 in·lb (7.3 N·m).
- 3.7. Tighten the bolt (4) inserted through the tab to 155 in·lb (17.5 N·m).
- 3.8. Install the motor wires, making sure they are connected to the correct motor terminals and that the terminal orientation is correct. **See Wiring Diagrams on page 12-4.** Tighten the terminal retaining nuts to 65 in·lb (7.3 N·m). Use a wrench on the bottom nuts to keep the terminals from moving.
- 3.9. Secure the white, orange, green, and blue wires with a wire tie so that none of the motor wires will scrub the motor or transaxle when the vehicle is in operation.
- 3.10. Connect the three-pin speed sensor plug to the vehicle wire harness.

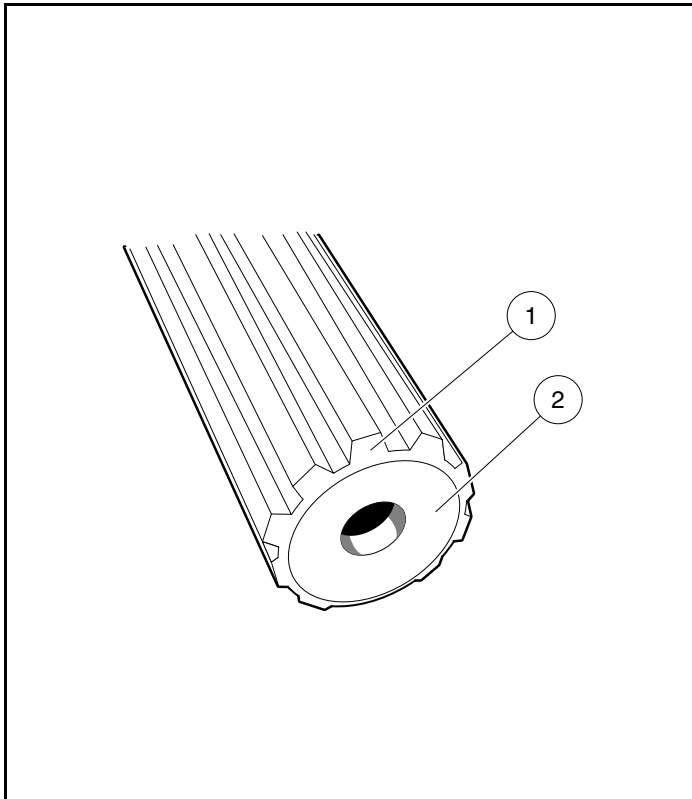

Figure 16-19 Clean Chamfer and Input Shaft End

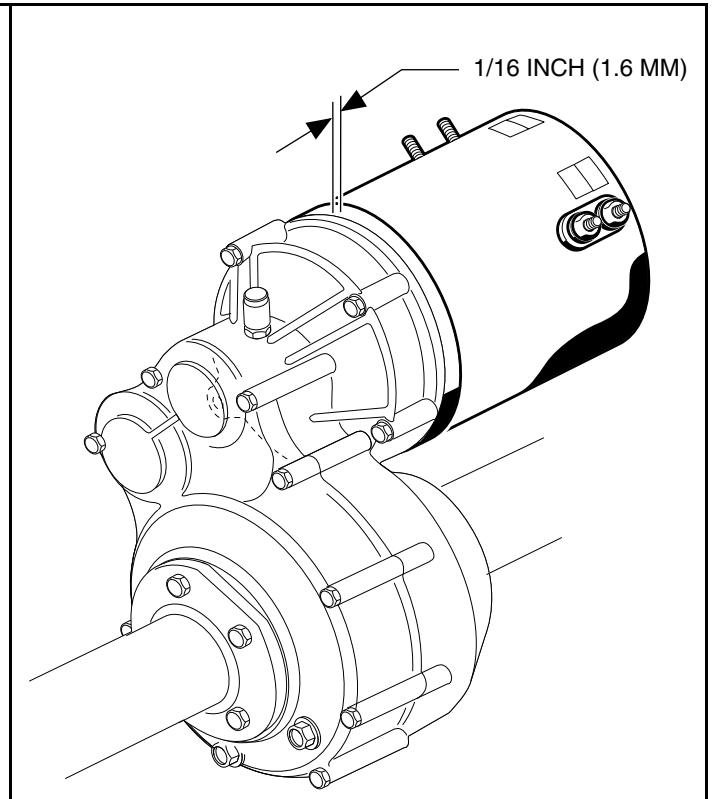

Figure 16-20 Gap at Motor and Transaxle

4. If using a chain hoist, lower the vehicle and guide the leaf springs into the shackles. If using a floor jack, raise the transaxle until the leaf springs can be guided into the shackles.
5. Insert the mounting bolts through the spring shackles and the bushings in the leaf spring eyes and install locknuts. Tighten the bolts to 23 ft·lb (31 N·m). **See Rear Suspension Section.**
6. Install the shock absorbers. Tighten nut until rubber bushing expands to the diameter of the cup washer.
7. If removed, install wheels and finger tighten the lug nuts.
8. Lift vehicle and remove jack stands. Lower vehicle to the floor and tighten lug nuts, using a crisscross pattern. **See Wheel Installation, Section 8, Page 8-1.**
9. Connect the batteries. **See Connecting the Batteries – Electric Vehicles, Section 1, Page 1-4.**
10. Place the Run/Tow switch in the RUN position.
11. Inspect the vehicle for proper operation. **See following WARNING.**

⚠ WARNING

- **Make sure that the vehicle operates in the forward direction when the Forward/Reverse switch is in the FORWARD position.**
- **Make sure that the vehicle operates in the reverse direction when the Forward/Reverse switch is in the REVERSE position. The reverse buzzer will sound as a warning when the Forward/Reverse switch is in REVERSE.**
- **Make sure that the vehicle does not operate when the Forward/Reverse switch is in the NEUTRAL position.**

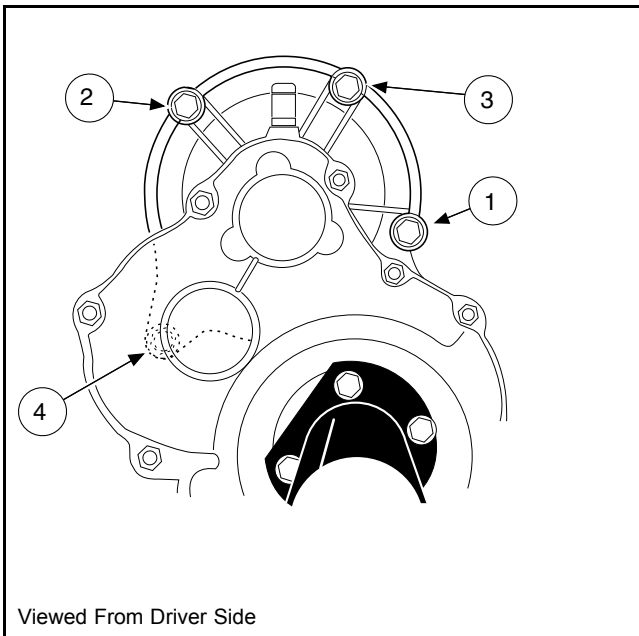

Figure 16-21 Motor Tightening Sequence

▲ DANGER

- See General Warnings on page 1-1.

▲ WARNING

- See General Warnings on page 1-1.

LUBRICATION

See General Warnings on page 1-1.

There are two plugs located on the lower half of the transaxle housing. The upper plug (21) (as viewed when the vehicle is on a level surface) is used as a lubricant level indicator (**Figure 17-5, Page 17-3**). When the vehicle is parked on a level surface, the lubricant level should be even with the bottom of the hole. The lower plug (22) is for draining the lubricant. When draining the lubricant, the upper plug should be removed so the lubricant will drain faster. Be sure the drain plug is installed before filling. **See following NOTE.**

***NOTE:** Recycle or dispose of used oil or lubricant in accordance with local, state, and federal regulations.*

AXLE BEARING AND SHAFT

See General Warnings on page 1-1.

AXLE SHAFT

Axle Shaft and Oil Seal Removal

1. Disconnect the batteries and discharge the controller. **See Disconnecting the Batteries – Electric Vehicles, Section 1, Page 1-4.**
2. Place chocks at the front wheels. Loosen lug nuts on rear wheels and lift the rear of the vehicle with a chain hoist or floor jack. Place jack stands under the axle tubes to support the vehicle. **See WARNING “Lift only one end...” in General Warnings on page 1-1.**
3. Remove the rear wheel and brake drum. **See Wheel Brake Assemblies Section and Wheels and Tires Section.**
4. Use 90° internal snap ring pliers to remove the internal retaining ring (1) from the axle tube (**Figure 17-1, Page 17-2**).
5. Remove the axle (2), retaining ring, and bearing assembly by pulling the axle straight out of the housing.
6. If necessary, remove the axle oil seal and adapter ring.
- 6.1. Use a bearing puller (CC P/N 1016417) to remove the axle seal and adapter ring from the axle tube (**Figure 17-2, Page 17-2**). **See following CAUTION and NOTE.**

CAUTION

- **Do not scar or damage the inside surfaces of the tube when removing the oil seal and adapter ring. A damaged tube might have to be replaced.**

***NOTE:** Do not discard the adapter ring. If the adapter ring is lost or damaged, the axle tube will have to be replaced.*

- 6.2. Use a press to separate the axle oil seal (15) from the adapter ring (39) (**Figure 17-3, Page 17-2**). Retain the adapter ring and discard the oil seal.

7. Inspect the axle shaft assembly to be sure the bearing and collar have not slipped and are still seated against the shoulder on the axle shaft.
8. Inspect bearing (5) (**Figure 17-5, Page 17-3**). If the bearing in a Type G transaxle is worn or damaged, the entire axle shaft assembly (1 or 2) must be replaced.

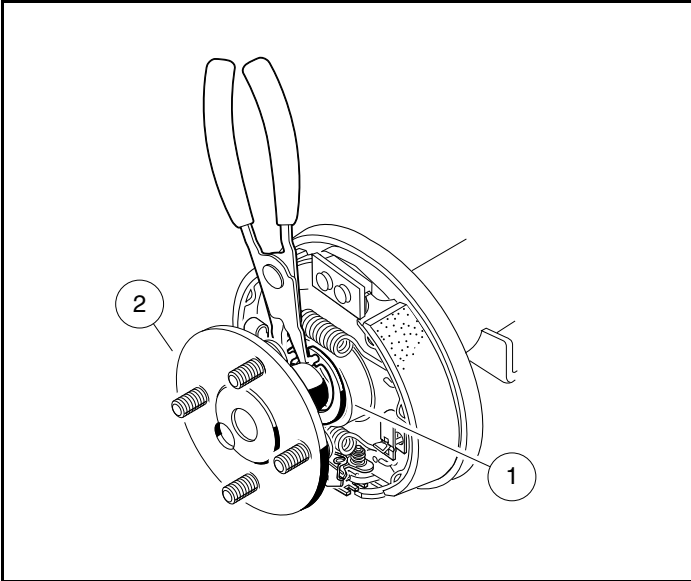

Figure 17-1 Remove Internal Retaining Ring

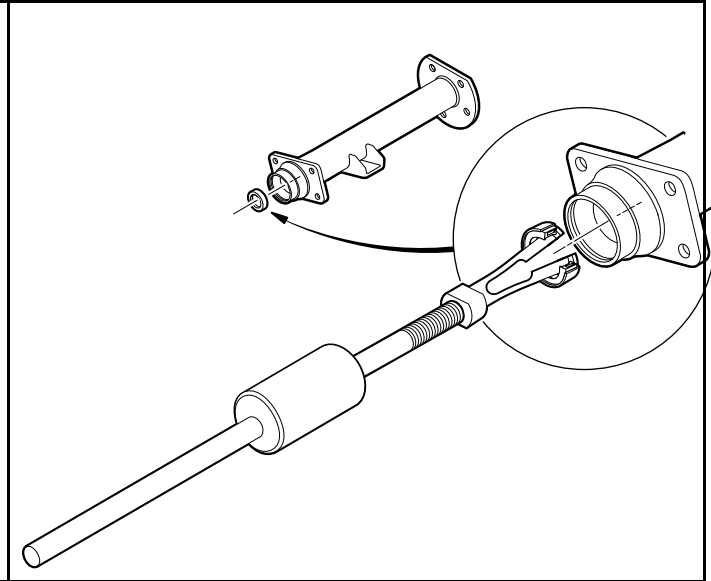

Figure 17-2 Axle Seal and Adapter Ring Removal

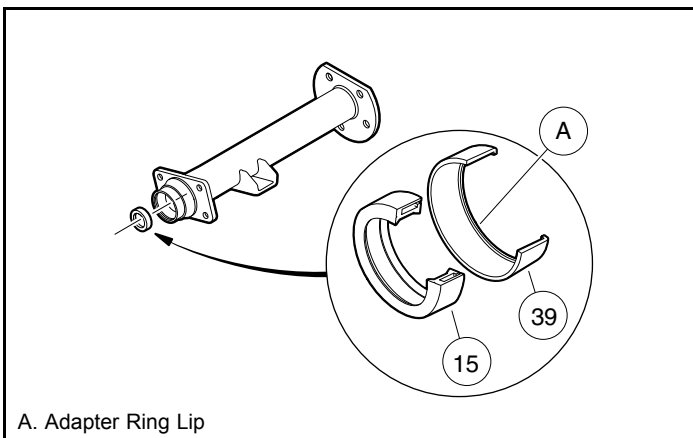

Figure 17-3 Axle Seal and Adapter Ring

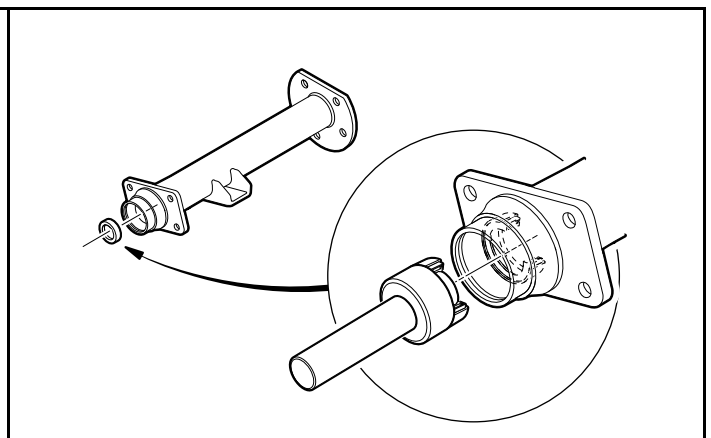

Figure 17-4 Axle Seal and Adapter Ring Installation

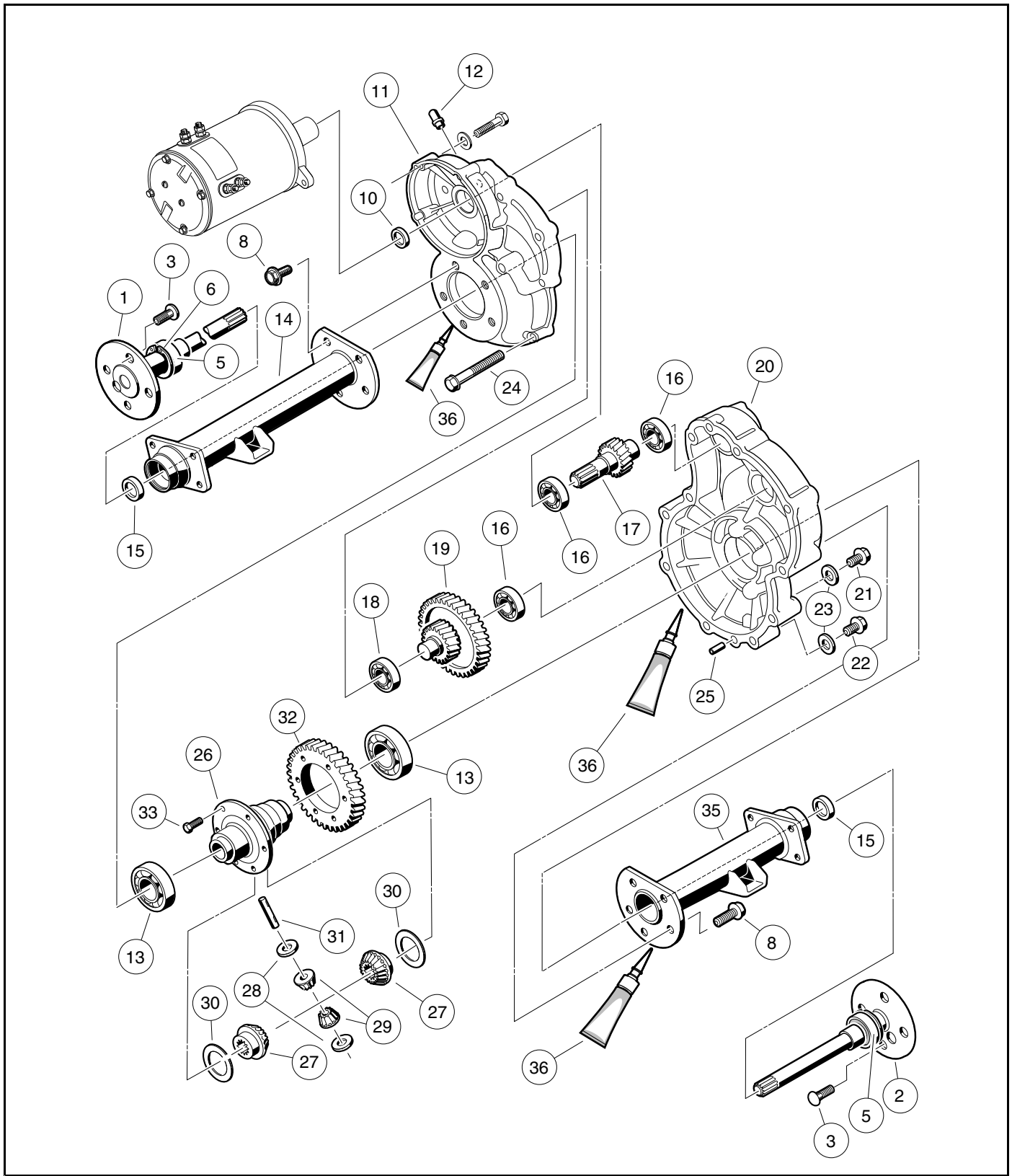

Figure 17-5 Transaxle – Type G

Axle Shaft and Oil Seal Installation

1. If previously removed, install a new oil seal.
 - 1.1. Clean seal seat in the adapter ring (39) (**Figure 17-3, Page 17-2**).
 - 1.2. Place a new seal (15) in the adapter ring with the seal lip facing toward the adapter ring lip (**Figure 17-3, Page 17-2**). Use an axle seal tool (CC P/N 1014162) and mallet to tap it in until it seats firmly in position (**Figure 17-3, Page 17-2**). A hydraulic press may also be used with the axle seal tool.
 - 1.3. Clean adapter ring seat(s) in the axle tube (14 or 35) (**Figure 17-5, Page 17-3**).
 - 1.4. Apply Loctite® 603 to the outer diameter of the adapter ring.
 - 1.5. Place the oil seal and adapter ring assembly into the axle tube with the seal lip facing away from the bearing (**Figure 17-4, Page 17-2**). Use an axle seal tool (CC P/N 1014162) and mallet to tap it in until it seats firmly in position. **See following CAUTION.**

CAUTION

- Clean any residual oil from the exposed end of the axle shaft and from the oil seal area prior to installing the axle shaft to prevent oil from coming in contact with brakes.
2. Install the rear axle into the transaxle. **See following NOTE.**
 - 2.1. Insert the shaft, splined end first, through the seal and into the axle tube. Be careful not to damage the seal on the inside of the axle tube hub. Advance the shaft through to the bearing on the shaft, then rotate it to align the shaft splines with the splined bore of the differential side gear (27) (**Figure 17-5, Page 17-3**). Continue advancing the shaft until the bearing on the axle is firmly seated within the axle tube hub seat.
 - 2.2. Use a pair of snap ring pliers to install the retaining ring (6) inside axle tube hub so that it seats against the axle bearing assembly and into the machined slot in the inside wall of the axle tube hub (**Figure 17-5, Page 17-3**). **See following NOTE.**

NOTE: If the retaining ring (6), axle bearing (5), or sleeve (4) must be replaced, the entire axle shaft assembly (1 or 2) must be replaced (**Figure 17-5, Page 17-3**).

- 2.3. Place a 1/4 to 3/8-inch (6 to 10 mm) diameter rod against the retaining ring and tap lightly at four to five locations around the retaining ring to ensure it is properly seated. **See following WARNING.**

⚠ WARNING

- Be sure the retaining ring is properly seated in its groove. If the ring is not properly installed, the axle assembly will separate from the transaxle and damage the axle assembly and other components. Loss of vehicle control could result, causing severe personal injury or death.
3. If a new oil seal was installed, allow 24 hours before operating the vehicle to allow the Loctite 603 to fully cure.
 4. Connect the batteries. **See Connecting the Batteries – Electric Vehicles, Section 1, Page 1-4.**

AXLE BEARING

Do not remove the axle bearing (5) from a Type G transaxle. If bearing is worn or damaged, the entire axle assembly (1 or 2) must be replaced (**Figure 17-5, Page 17-3**).

TRANSAXLE

See General Warnings on page 1-1.

TRANSAXLE REMOVAL

1. Disconnect the batteries and discharge the controller. **See Disconnecting the Batteries – Electric Vehicles, Section 1, Page 1-4.**
2. Place chocks at the front wheels and slightly loosen lug nuts on both rear wheels.
3. Place a floor jack under the transaxle and raise the rear of the vehicle. Position jack stands under the frame crossmember between the spring mount and the side stringer, just forward of each rear wheel. Lower the vehicle to let the jack stands support the vehicle (**Figure 17-6, Page 17-5**). **See WARNING “Lift only one end of the vehicle...” in General Warnings on page 1-1.**
4. Remove the rear wheels, then thread one lug nut onto a stud on each rear hub. This will keep the brake drums on the hubs.
5. Remove the bow tie pins (1), brake cable clevis pins (2), and cable retaining E-clips (3). Disconnect the brake cables (4) (**Figure 17-7, Page 17-5**).

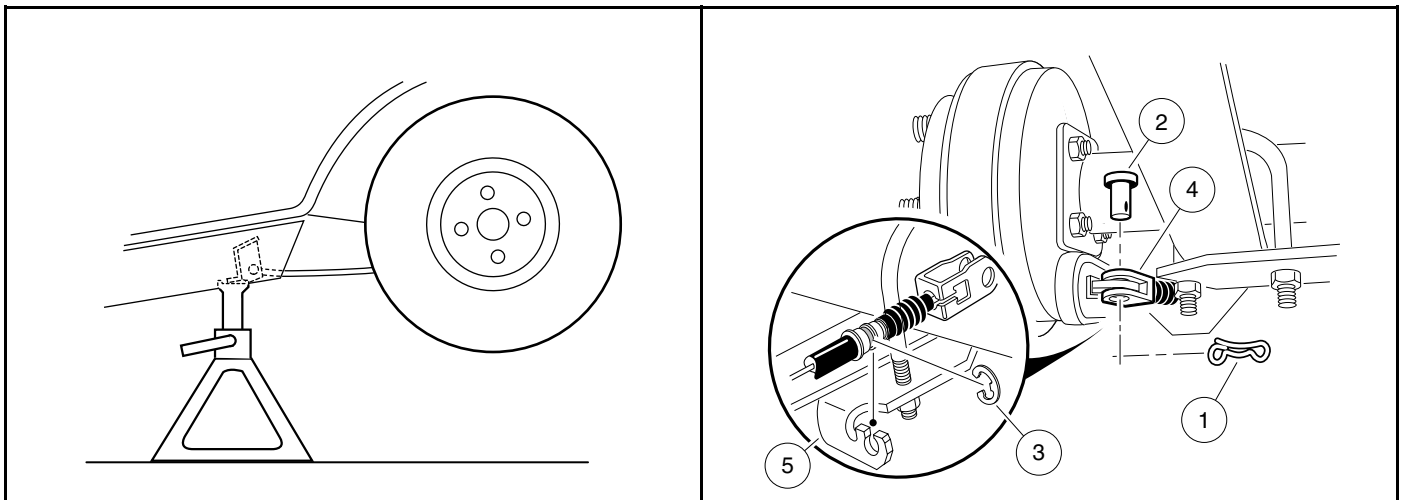

2600-30000-10369

Figure 17-6 Vehicle Supported on Jack Stands

Figure 17-7 Brake Cables

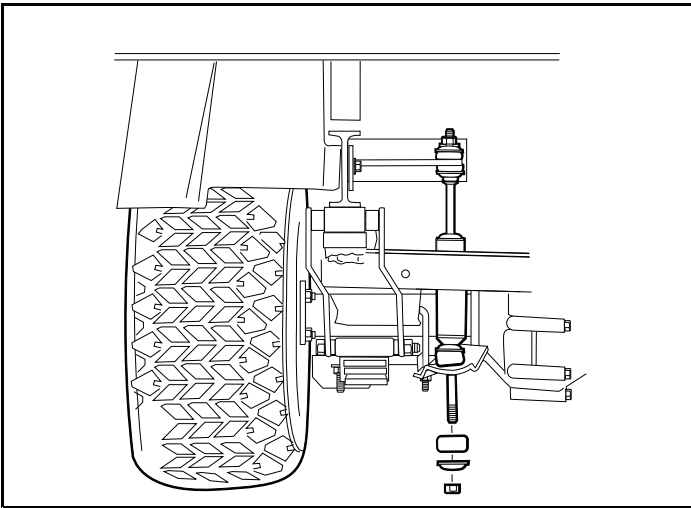

2629

Figure 17-8 Disconnect Shocks

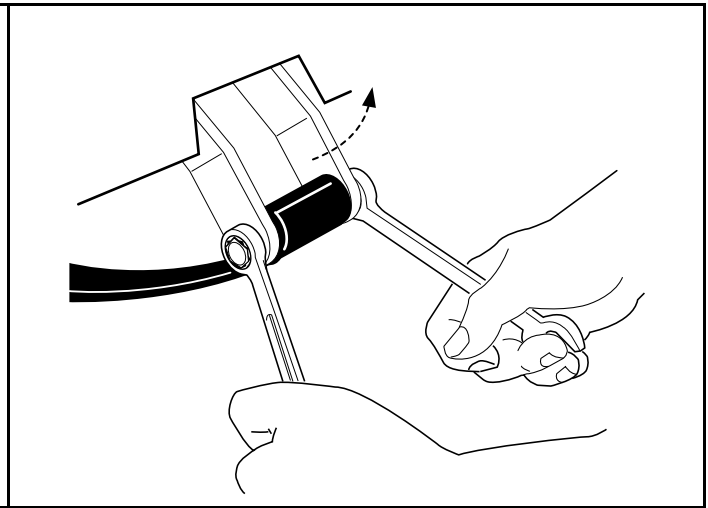

2631

Figure 17-9 Detach Spring From Shackles

6. Disconnect the shock absorbers from their lower mounts (**Figure 17-8, Page 17-6**).
7. Disconnect the four motor wires. Use two wrenches to prevent the post from turning.
8. With a floor jack supporting the transaxle, remove lower spring shackle nuts and bolts. Rotate shackles up and away from springs (**Figure 17-9, Page 17-6**).
9. If a chain hoist was used to raise the vehicle, lift the vehicle high enough to permit easy access and clearance for removal of the motor. If a floor jack was used to raise the vehicle, lower the transaxle enough to permit easy access and clearance for removal of the motor.
10. Remove the three motor mounting bolts (**Figure 17-11, Page 17-7**) and the motor positioning bolt (**Figure 17-12, Page 17-7**) mounting the motor to the transaxle. **See following CAUTION.**

⚠ CAUTION

- Do not position fingers under motor when sliding motor off of the input shaft. Fingers may get pinched when motor disengages.

CAUTION CONTINUED ON NEXT PAGE

⚠ CAUTION

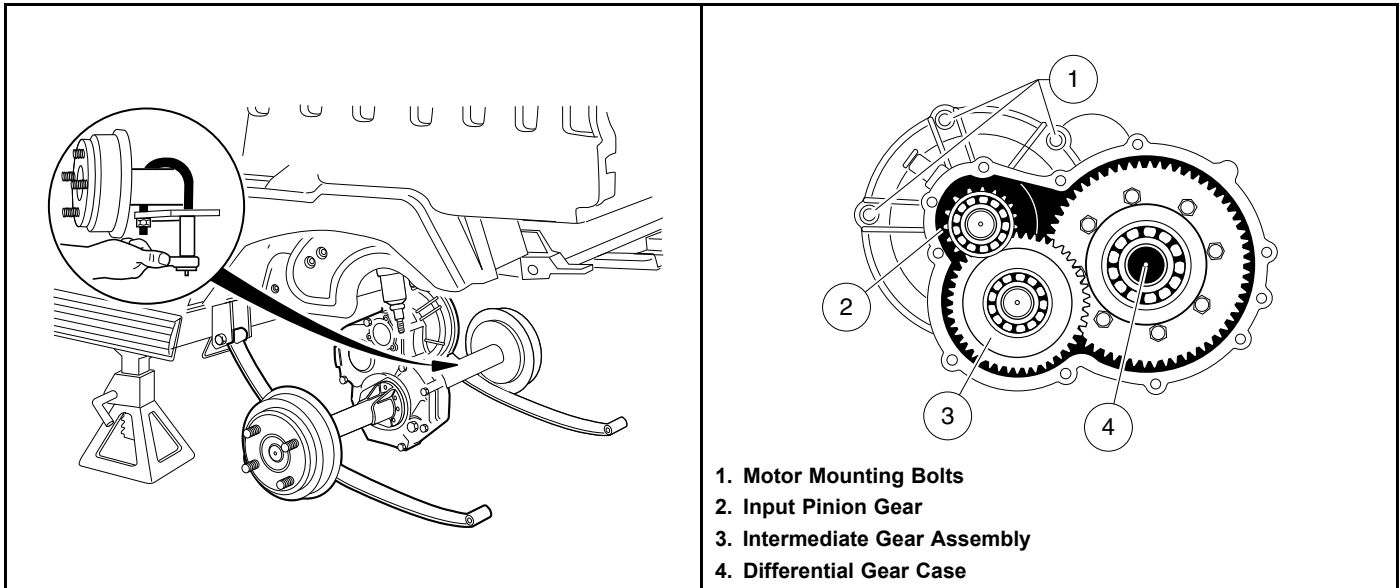

2639

Figure 17-10 Detach Axle From Leaf Springs

Figure 17-11 Motor Mounting Bolts and Gear Assembly

11. Carefully remove the motor from the transaxle. Slide the motor away from the transaxle until the motor spline becomes disengaged from the input shaft, then lift motor out. **See preceding WARNING.**
12. If a floor jack was used, pull floor jack from beneath the transaxle and allow the springs to rest on the floor.
13. Remove the U-bolts attaching the transaxle to the leaf springs (**Figure 17-10, Page 17-7**).
14. Carefully lift each end of the transaxle off its positioning pin (on the leaf spring) and slide the transaxle to the rear and out of the vehicle.
15. Drain the lubricant from the transaxle and remove the axle shafts. **See Axle Shaft and Oil Seal Removal on page 17-1. See following NOTE.**

NOTE: Recycle or dispose of used oil or lubricant in accordance with local, state, and federal regulations.

16. Remove the brake assemblies if required. **See Wheel Brake Assemblies Section.**

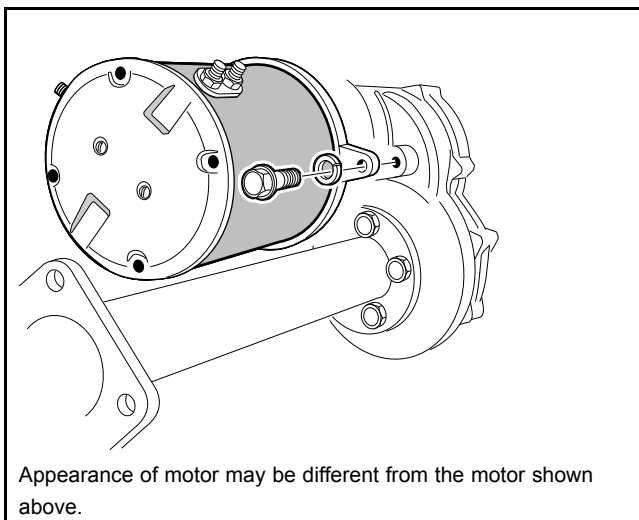

Figure 17-12 Motor Positioning Bolt

TRANSAXLE DISASSEMBLY, INSPECTION, AND ASSEMBLY

See General Warnings on page 1-1.

TRANSAXLE DISASSEMBLY AND INSPECTION

1. To detach axle tubes (14 and 35) from the transaxle housing, remove the bolts (8) (**Figure 17-5, Page 17-3**).
2. Remove 11 bolts (24) that hold housing together.
3. Pull the halves of the housing (11 and 20) apart. If necessary, tap lightly on the spline of the input pinion (17).
See following CAUTION.

CAUTION

- To prevent damage to the housing mating seal surfaces, use caution when separating halves.
4. Remove input pinion gear (17) by pulling gear out while rocking intermediate gear assembly (19). Lift intermediate gear assembly and differential gear case unit out simultaneously (**Figure 17-5, Page 17-3**). **See following CAUTION.**

CAUTION

- Do not damage gears. Use extreme care when handling them.
5. Use a bearing puller or arbor press to remove bearings (16) from the input pinion gear. If the oil seal (10) is damaged, replace it (**Figure 17-5, Page 17-3**). **See also Figure 17-13, Page 17-8. See following CAUTION.**

CAUTION

- Do not reuse bearings after removing them. Replace bearings with new ones.
6. To disassemble the intermediate gear assembly, press off together the bearing (16) and the gear (19) (**Figure 17-5, Page 17-3**). **See also Figure 17-13, Page 17-8.**
 7. Press the bearing (18) off the intermediate gear assembly (**Figure 17-5, Page 17-3**).

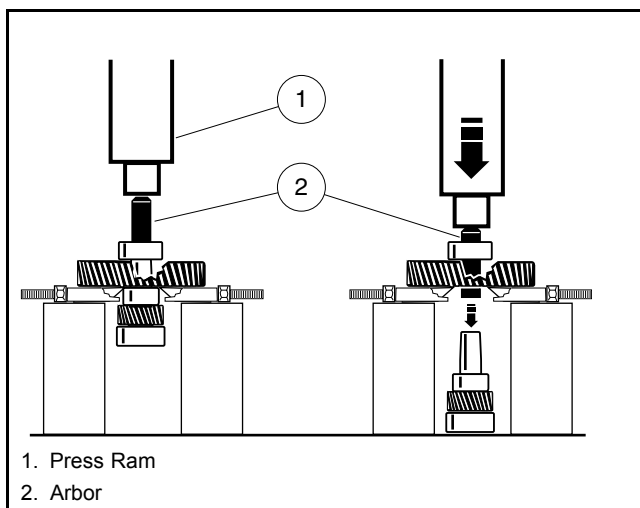

Figure 17-13 Intermediate Gear Assembly

8. Disassemble the differential gear case:
 - 8.1. Remove the hex bolts (33) and the ring gear (32) from the differential case (**Figure 17-5, Page 17-3**).
 - 8.2. Remove the ring gear.
 - 8.3. Separate the differential gear case housing. If necessary, install two of the hex bolts (removed previously in step 8.1) into the differential gear unit and, while holding the unit slightly above the work area, lightly tap the bolt heads (**Figure 17-14, Page 17-9**). Remove the two bolts.

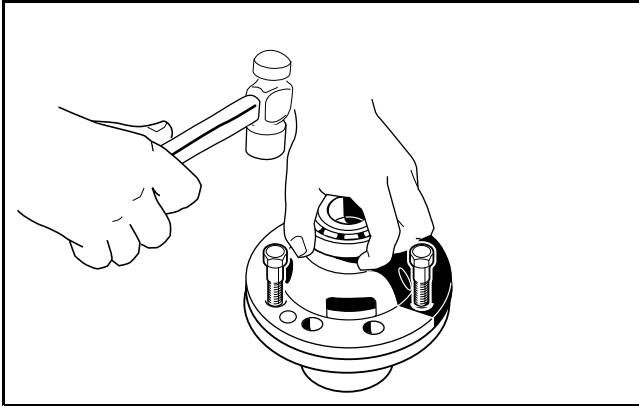

Figure 17-14 Separate Housing

- 8.4. Remove the differential pin (31) by pushing pin through differential gear case from one side (**Figure 17-5, Page 17-3**). **See also Figure 17-15, Page 17-9.**
- 8.5. Remove the idler gears (1 and 2) and thrust plates (3 and 4) (**Figure 17-16, Page 17-9**).

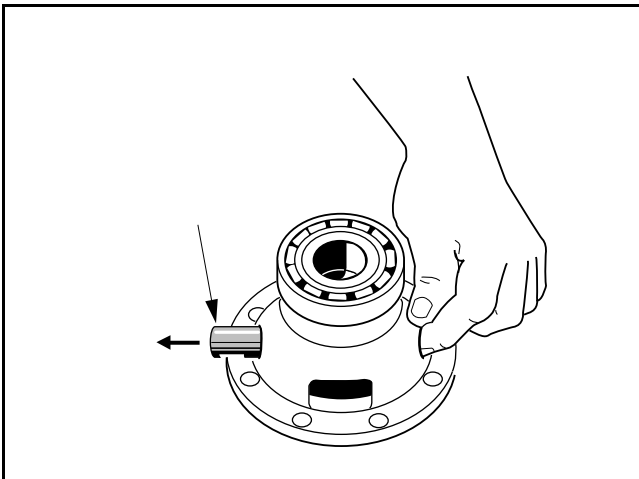

Figure 17-15 Differential Pin

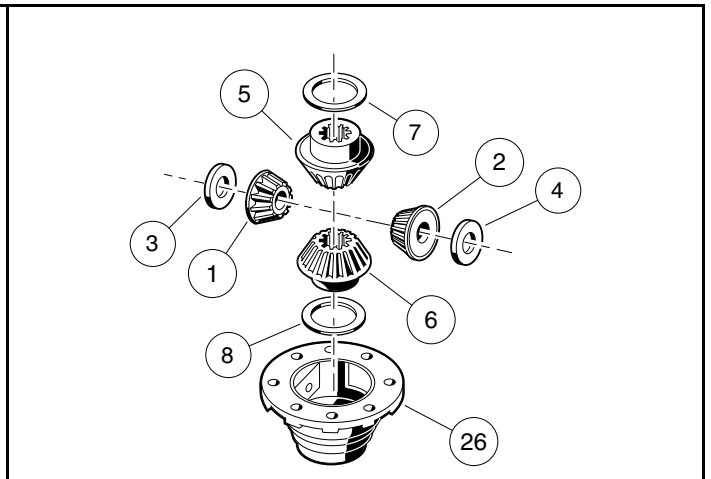

Figure 17-16 Left Differential

- 8.6. Remove the differential gears (5 and 6) and thrust plates (7 and 8).
- 8.7. Inspect the bearings (13) of the differential case (26) and replace them if they are damaged (**Figure 17-5, Page 17-3**). To remove them, press them off. **See following CAUTION.**

CAUTION

- **Do not reuse bearings after removing them. Replace bearings with new ones.**

9. Inspect parts for wear or damage. Any worn or damaged parts should be replaced. **See following NOTE.**

NOTE: Damaged or worn gears should be replaced as sets.

TRANSAXLE ASSEMBLY

CAUTION

- Do not press against the bearing outer race.
 - The housing and all parts must be wiped clean and dry before reassembly.
1. If bearings (13) were removed during disassembly, install new bearings using an arbor press (**Figure 17-5, Page 17-3**).
 2. Assemble the differential gear case.
 - 2.1. Install the pin (31) (**Figure 17-5, Page 17-3**). Apply a small amount of oil to all thrust plates and to both ends of the pin.
 - 2.2. Install the hex bolts (33) and output gear (32). Tighten bolts to 58 ft·lb (78.6 N·m).
 3. Press a new bearing (18) onto the intermediate gear assembly (**Figure 17-5, Page 17-3**).
 4. Press new bearing (16) onto input pinion gear (17).
 5. Apply grease to the lip of the new oil seal (10) and install the seal using a transaxle pinion seal tool (CC P/N 1014161). The lip of the oil seal should face the inside of the transaxle housing. Make sure the seal is firmly seated.
 6. Install the differential assembly, the intermediate gear assembly, and the input pinion gear simultaneously. Be sure all bearings are seated properly in the housing. Rotate the input shaft to check for smooth gear operation (**Figure 17-11, Page 17-7**).
 7. Install both dowel pins (25) in the transaxle housing (20) (**Figure 17-5, Page 17-3**).
 8. Install left half of transaxle housing:
 - 8.1. Place a 1/8-inch (3 mm) bead of Three Bond liquid gasket on mating surface of housing.
 - 8.2. Install left half of transaxle housing (20) (**Figure 17-5, Page 17-3**).
 - 8.3. Install eleven bolts (24) in the case housing and tighten to 19 ft·lb (25.7 N·m). Type G transaxles have no shims or gasket.
 - 8.4. Install axle tube (14 and 35) with bolts (8) (**Figure 17-5, Page 17-3**). Tighten the bolts to 37 ft·lb (50.2 N·m).
 9. Install the brake assemblies as instructed. **See Wheel Brake Assemblies Section.**
 10. Apply a small amount of grease to the lip of the oil seal (15) (**Figure 17-5, Page 17-3**). **See following CAUTION.**

⚠ CAUTION

- Clean any residual oil from the exposed end of the axle shaft and from the oil seal area prior to installing the axle shaft to prevent oil from coming in contact with brakes.
11. Install the rear axle onto the transaxle.
 - 11.1. Insert the splined end of the axle shaft into the axle tube. Be careful not to damage the seal on the inside of the axle tube hub. Advance the shaft through to the bearing on the shaft, and rotate it to align the shaft splines with the splined bore of the differential gear. Continue advancing the shaft until the bearing on the axle is firmly seated within the axle tube hub seat.
 - 11.2. Using 90° internal snap ring pliers (0.090 tip) (CC P/N 1012560), attach the internal retaining ring into the axle tube hub so that it seats against the axle bearing assembly and into the machined slot in the inside wall of the axle tube hub (**Figure 17-5, Page 17-3**).
 - 11.3. Place a 1/4 to 3/8-inch (6 to 10 mm) diameter rod against the retaining ring and tap lightly at four or five locations to ensure it is properly seated. **See following WARNING.**

⚠ WARNING

- **Be sure retaining ring is properly seated in its groove. If ring is not properly installed, the axle assembly will separate from the transaxle and damage the axle assembly and other components. Loss of vehicle control could result in severe personal injury or death.**
12. Make sure the drain plug (22) is installed in the transaxle and tightened to 23 ft·lb (31 N·m). Fill the transaxle, through the level indicator hole, with 22 ounces of SAE 30 API Class SE, SF, or SG oil (a higher grade may also be used). Install and tighten the level indicator plug (21) to 23 ft·lb (31 N·m).

TRANSAXLE INSTALLATION

See General Warnings on page 1-1.

1. If using a chain hoist, raise the vehicle and place transaxle in position on the jack stands. If using a floor jack, lower the jack stands to their lowest settings and place the transaxle in position on the jack stands.
2. Align the center hole in the saddle of the transaxle with the pilot bolt in the leaf spring assembly.
3. Install the two U-bolts, jounce bumper mount (if required), and spacers, lockwashers, and nuts. Tighten the nuts to 25 ft·lb (34 N·m). Tighten the U-bolt nuts so an equal amount of thread is visible on each leg of the bolt.
4. Install the motor. **See Motor Installation on page 16-13.**
5. If using a chain hoist, lower the vehicle while guiding the leaf springs into the rear spring shackles. If using a floor jack, raise the differential while guiding the leaf springs into the rear spring shackles. Then raise the jack stands to support the transaxle.
6. Connect the four motor wires. Tighten the retaining nuts to 65 in·lb (7.3 N·m). Use two wrenches to prevent the posts from turning. **See following NOTE.**

NOTE: If the motor wires were not tagged when disconnected, refer to the wiring diagram for proper connection. See **Wiring Diagrams, Section 12, Page 12-4.**

7. Insert bolts through the spring shackles and bushings in the leaf spring eyes. Secure bolts with locknuts. Tighten to 15 ft·lb (20.3 N·m).
8. Connect the brake cables using new bow tie pins (1) (**Figure 17-7, Page 17-5**).
9. Install the shock absorbers. Tighten shock absorber retaining nuts until the rubber bushings expand to the same size as the cup washers.
10. Install the rear wheels and finger-tighten the lug nuts.
11. Lift the vehicle and remove the jack stands.
12. Lower vehicle and tighten the lug nuts using a crisscross pattern. **See Wheel Installation, Section 8, Page 8-1.**
13. Connect the batteries. **See Connecting the Batteries – Electric Vehicles, Section 1, Page 1-4.**
14. Inspect the vehicle to check for proper operation. **See following WARNING.**

⚠ WARNING

- **Make sure that the vehicle operates in the forward direction when the Forward/Reverse switch is in the FORWARD position.**
- **Make sure that the vehicle operates in the reverse direction when the Forward/Reverse switch is in the REVERSE position. The reverse buzzer will sound as a warning when the Forward/Reverse switch is in REVERSE.**
- **Make sure that the vehicle does not operate when the Forward/Reverse switch is in the NEUTRAL position.**

⚠ DANGER

- See General Warnings on page 1-1.

⚠ WARNING

- See General Warnings on page 1-1.

GENERAL INFORMATION

⚠ WARNING

- To prevent damage to the ECU, never mix the black and gray connectors that attach to it. The black connector is tethered to the ECU mounting plate to help avoid installing it in the gray port.

This section contains the information required to correctly troubleshoot the EFI gas vehicle. In addition to troubleshooting, this section contains general information on the electrical system and the circuits of the electrical system.

ACCESSORIES

For powered accessories that do not need to be controlled by the key switch, use the red/white and black/yellow wires with female, quick-disconnect terminals located behind the instrument panel.

LOW OIL WARNING LIGHT

NOTE: When the key switch is placed in the ON position, the Low Oil Warning Light will illuminate for approximately 3 seconds as a bulb check function.

If the Low Oil Warning Light comes ON due to low oil level, and oil is added to correct the issue, the Low Oil Warning Light will still remain ON. Cycle the key switch OFF and ON to reset the Low Oil Warning Light.

The gasoline vehicle is equipped with a low oil warning light (4), located at the top of the instrument panel. If the warning light comes on, oil should be checked and added to the engine as necessary before continuing to use the vehicle. **See following CAUTION.** The vehicle should never be driven when the low oil warning light remains on. If the warning light goes on and off, the vehicle may be driven, but oil should be added at the first opportunity. The light will flash repeatedly to indicate a possible problem with the electronic fuel injection (EFI) system. If the oil level is correct and the warning light stays on, have a trained technician check the vehicle.

CAUTION

- Failure to add oil immediately when the low oil warning light stays on may result in permanent engine damage.

GROUND LOCATIONS

Electrical grounds are located at the following areas:

- **Below the Battery:** The battery, starter/generator, voltage regulator and main wire harness are all grounded to the chassis on the frame rail below the battery.
- **In Front of Engine:** The engine is grounded to the chassis cross-member with an un-insulated, braided wire.

- **Top of Fuel Tank:** The fuel tank is grounded to the chassis through the main wire harness.

FEATURES OF THE ELECTRONIC FUEL INJECTION (EFI) SYSTEM

- Open-loop system (i.e. oxygen sensor not used)
- Controls fuel pump, fuel injector, oil lamp
- Inputs: Manifold Absolute Pressure (MAP), engine block temperature, ignition timing
- Blink fault codes through the Low Oil Warning Lamp
- Separate EFI wire harness
- The ECU and throttle body/fuel injector assembly are matched pairs

TROUBLESHOOTING GUIDE

The following troubleshooting guides will be helpful in identifying operating difficulties should they occur. The guides include the symptom, probable cause(s) and suggested checks. The procedures used in making these checks can be found in the referenced sections of the maintenance and service manual.

ECU ERROR CODES (DISPLAYED BY THE LOW OIL WARNING LIGHT)

Failure Mode Table – When Ignition Is Initially Switched ON

DISPLAY MODE	CONDITION	LAMP CONTROL
Blink Code	No Failure	Step 1: Lamp ON Two Seconds
		Step 2: Lamp OFF Four Seconds
		Step 3: Lamp OFF
	Detect Failure	Step 1: Lamp ON Two Seconds
		Step 2: Lamp OFF Four Seconds
		Step 3: Display Blink Code

Failure Mode Table – After Ignition Has Been In ON Position (i.e. During Use of Vehicle)

DISPLAY MODE	CONDITION	LAMP CONTROL
Blink Code	No Failure	Step 1: Lamp OFF
	Detect Failure	Step 1: Lamp OFF Four Seconds
		Step 2: Display Blink Code

Error Codes – ECU

BLINK CODE	CODE DESCRIPTION	CORRECTIVE ACTION
21	Low Battery Voltage	Check battery voltage. Charge/replace battery as necessary.
22	MAP Sensor: Open or Shorted Connection	Check connector at ECU & Throttle module. If connection is made and no corrosion is present, replace ECU and Throttle Module.
23	Temperature Sensor: Open or Shorted Connection	Check connector at ECU & Throttle module. If connection is made and no corrosion is present, replace ECU and Throttle Module.
31	Fuel Pump: Open Connection	Check fuel pump and fuel system. Check electrical connections at ECU, Throttle module and fuel pump.
41	Fuel Injector: Open Connection	Check connector at ECU & Throttle module. If connection is made and no corrosion is present, replace ECU and Throttle Module.
51	Ignition Pulse: Open Connection	Check spark plug, coil, ECU. Replace failed components.

NOTE: *If codes 22, 23, and 41 blink in-sequence, the gray plug is disconnected from the ECU.*

If no codes blink, the black plug is disconnected from the ECU.

GASOLINE POWERTRAIN

TROUBLESHOOTING GUIDE		
SYMPTOM	POSSIBLE CAUSES	CORRECTIVE ACTION
Engine does not start easily.	Spark plug is partially fouled or in poor condition	Clean or replace
	Spark plug is damaged or loose	Replace or tighten
	Incorrect spark plug gap	Adjust gap
	Spark plug wire is damaged or loose	Replace or reconnect
	Loose wire connection at ignition coil	Test Procedures 15 – <i>Ignition Spark</i> and 16 – <i>Ignition Coil</i>
	Intermittent ignition coil failure	Test Procedures 15 – <i>Ignition Spark</i> and 16 – <i>Ignition Coil</i>
	Low fuel level in fuel tank	Refill
	Fuel line pinched or clogged	Clean or replace
	Poor fuel quality or contaminated fuel	Replace
	Water or dirt in the fuel system and/or throttle body/fuel injector; dirty or clogged fuel filter	Section 23 — Fuel System: Gasoline Vehicles
	Throttle body dirty or improperly adjusted	Clean or adjust. Section 23 — Fuel System: Gasoline Vehicles
	Low cylinder compression	Section 22 — Engine (Subaru EX40)
	Cylinder head bolts not tighten properly	Check and retighten. Section 22 — Engine (Subaru EX40)
	Intake or exhaust valve not sealing	Repair. Section 22 — Engine (Subaru EX40)
	Incorrect valve clearance	Adjust. Section 22 — Engine (Subaru EX40)
	Vacuum leak	Retighten hardware or replace gasket(s)
Engine starts but does not run smoothly.	Starter/generator belt is slipping	Belt Tension Adjustment for EFI Engines on page 20-13
	Spark plug is fouled or in poor condition	Section 22 — Engine (Subaru EX40)
	Spark plug wire is damaged or loose	Section 22 — Engine (Subaru EX40)
	Intermittent ignition coil failure	Test Procedures 15 – <i>Ignition Spark</i> and 16 – <i>Ignition Coil</i>
	Water or dirt in the fuel system and/or throttle body/fuel injector; dirty or clogged fuel filter	Section 23 — Fuel System: Gasoline Vehicles
Fuel pump malfunction; fuel pressure to throttle body too low	Section 23 — Fuel System: Gasoline Vehicles	

TABLE CONTINUED ON NEXT PAGE

TROUBLESHOOTING GUIDE		
SYMPTOM	POSSIBLE CAUSES	CORRECTIVE ACTION
Engine turns but fails to start.	Fuel tank is empty	Section 23 — Fuel System: Gasoline Vehicles
	Fuel line or filter clogged	Section 23 — Fuel System: Gasoline Vehicles
	Fouled spark plug	Section 22 — Engine (Subaru EX40)
	Spark plug wire damaged or loose	Section 22 — Engine (Subaru EX40)
	Loose wire connection at ignition coil	Test Procedures 15 – <i>Ignition Spark</i> and 16 – <i>Ignition Coil</i>
	Ignition coil failed	Test Procedures 15 – <i>Ignition Spark</i> and 16 – <i>Ignition Coil</i>
	Kill circuit grounded	Test Procedures 14 – <i>Kill Limit Switch – Pedal-Start Vehicles Only</i> and 6 – <i>Key Switch (Engine Kill Circuit)</i>
	Fuel pump malfunction or failure	Section 23 — Fuel System: Gasoline Vehicles
Engine overheats.	Fan screen is partially blocked or plugged	Section 22 — Engine (Subaru EX40)
	Governor is improperly adjusted	Section 23 — Fuel System: Gasoline Vehicles
	Excessive back pressure in exhaust	Check and clean or replace
	Fuel/air mixture is too lean; check EFI	Section 23 — Fuel System: Gasoline Vehicles
	Overloading	Reduce to rated load
	Poor quality engine oil	Replace
Engine pre-ignites.	Excessive carbon deposits on piston head or in combustion chamber	Section 22 — Engine (Subaru EX40)
	Spark plug heat range is incorrect	Section 22 — Engine (Subaru EX40)
	Unsuitable or contaminated fuel	Section 23 — Fuel System: Gasoline Vehicles
Loss of engine power.	Exhaust valve is restricted with carbon deposit	Section 22 — Engine (Subaru EX40)
	Muffler or exhaust pipe restricted with carbon or other substance	Section 24 — Exhaust System: Gasoline Vehicles
	Ignition coil failed	Test Procedures 15 – <i>Ignition Spark</i> and 16 – <i>Ignition Coil</i>
	Air filter is dirty or clogged	Section 23 — Fuel System: Gasoline Vehicles
	Governor is improperly adjusted	Section 23 — Fuel System: Gasoline Vehicles
	Throttle linkage out of adjustment	Section 23 — Fuel System: Gasoline Vehicles
	Low cylinder compression	Section 22 — Engine (Subaru EX40)
	Spark plug failed	Section 22 — Engine (Subaru EX40)
	Restricted fuel flow	Section 23 — Fuel System: Gasoline Vehicles
	Torque converter is not backshifting properly	Section 25 — Clutches: Gasoline Vehicles

TABLE CONTINUED ON NEXT PAGE

TROUBLESHOOTING GUIDE		
SYMPTOM	POSSIBLE CAUSES	CORRECTIVE ACTION
Spark plug fouls repeatedly.	Incorrect plug	Section 22 — Engine (Subaru EX40)
	Spark plug wire is damaged	Section 22 — Engine (Subaru EX40)
	Unsuitable fuel, or incorrect (rich) fuel mixture	Section 23 — Fuel System: Gasoline Vehicles
	Ignition coil failed	Test Procedures 15 – <i>Ignition Spark</i> and 16 – <i>Ignition Coil</i>
	Dirt entering combustion chamber	Check intake system for leaks. Section 23 — Fuel System: Gasoline Vehicles
	Rings are heavily worn, low cylinder pressure	Section 22 — Engine (Subaru EX40)
Starter fails to operate.	Neutral lockout switch is in the MAINTENANCE position	Place switch in the OPERATE position.
	Fuse is blown	Test Procedure 2 – <i>Fuses</i>
	Battery is dead	Test Procedure 1 – <i>Battery</i>
	Starter control circuit is not operating	Test Procedure 5 – <i>Key Switch (Start Circuit)</i>
	Starter/generator failed	Test Procedure 12 – <i>Starter/Generator (Starter Function)</i>
	Starter solenoid failed	Test Procedure 8 – <i>Solenoid</i>
	Accelerator pedal limit switch failed	Test Procedure 7 – <i>Accelerator Pedal Limit Switch – Pedal-Start Vehicles Only</i>
	Key switch failed	Test Procedure 5 – <i>Key Switch (Start Circuit)</i>
	Neutral lockout limit switch failed	Test Procedure 10 – <i>Neutral Lockout Limit Switch – Pedal-Start Vehicles Only</i>
	Loose or broken wire in starter/generator circuit	Section 20 — Electrical Components: Pedal-Start Gas Vehicle Starter/Generator on page 20-1
Starter/generator does not charge battery.	Cylinder and/or crankcase flooded with fuel	Section 23 — Fuel System: Gasoline Vehicles
	Loose or broken wire in the starter/ generator circuit	Test Procedure 11 – <i>Starter/Generator (Generator Function)</i>
	Generator field coil is shorted	Test Procedure 11 – <i>Starter/Generator (Generator Function)</i>
	Brushes are worn or commutator is dirty	Section 20 — Electrical Components: Pedal-Start Gas Vehicle Starter/Generator on page 20-1
	Starter/generator belt is loose or slipping	Belt Tension Adjustment for EFI Engines on page 20-13
	Voltage regulator failed	Test Procedure 13 – <i>Voltage Regulator</i>
Battery failed	Test Procedure 1 – <i>Battery</i>	

TABLE CONTINUED ON NEXT PAGE

TROUBLESHOOTING GUIDE		
SYMPTOM	POSSIBLE CAUSES	CORRECTIVE ACTION
Transmission does not engage or disengage smoothly.	Transmission shifter linkage is binding or is out of adjustment	Section 26 — Transaxle (ED65): Gasoline Vehicles
	Insufficient (low) level of lubricant or wrong type of lubricant in transmission	Section 26 — Transaxle (ED65): Gasoline Vehicles
	Internal gears are damaged or worn	Section 26 — Transaxle (ED65): Gasoline Vehicles
	Dog clutch jammed or broken	Section 26 — Transaxle (ED65): Gasoline Vehicles
Excessive vehicle vibration.	Engine mounting nuts or bolts are loose	Section 22 — Engine (Subaru EX40)
	Snubber on frame is worn or damaged	Section 22 — Engine (Subaru EX40)
	Loose muffler mounting hardware	Section 24 — Exhaust System: Gasoline Vehicles
	Damaged drive belt or starter belt	Section 25 — Clutches: Gasoline Vehicles
	Damaged drive clutch	Section 25 — Clutches: Gasoline Vehicles
	Damaged starter/generator pulley	Section 20 — Electrical Components: Pedal-Start Gas Vehicle Starter/Generator on page 20-1
Clutches do not shift smoothly.	RPM setting is incorrect	Section 23 — Fuel System: Gasoline Vehicles Engine RPM Adjustment on page 23-13
	Drive belt is worn, cracked, glazed, or frayed	Section 25 — Clutches: Gasoline Vehicles
	Drive clutch malfunction	Section 25 — Clutches: Gasoline Vehicles
Engine won't stop running.	Governor is sticking	Section 26 — Transaxle (ED65): Gasoline Vehicles
	Kill circuit wire is disconnected from the ignition coil	Test Procedure 14 – <i>Kill Limit Switch – Pedal-Start Vehicles Only</i>
	Accelerator pedal linkage out of adjustment causing engine kill limit switch not to activate	Section 23 — Fuel System: Gasoline Vehicles
	Fuel mixture is too lean; check EFI	Section 23 — Fuel System: Gasoline Vehicles
	Throttle stop screw out of adjustment at governor arm	Section 23 — Fuel System: Gasoline Vehicles

WIRING DIAGRAMS

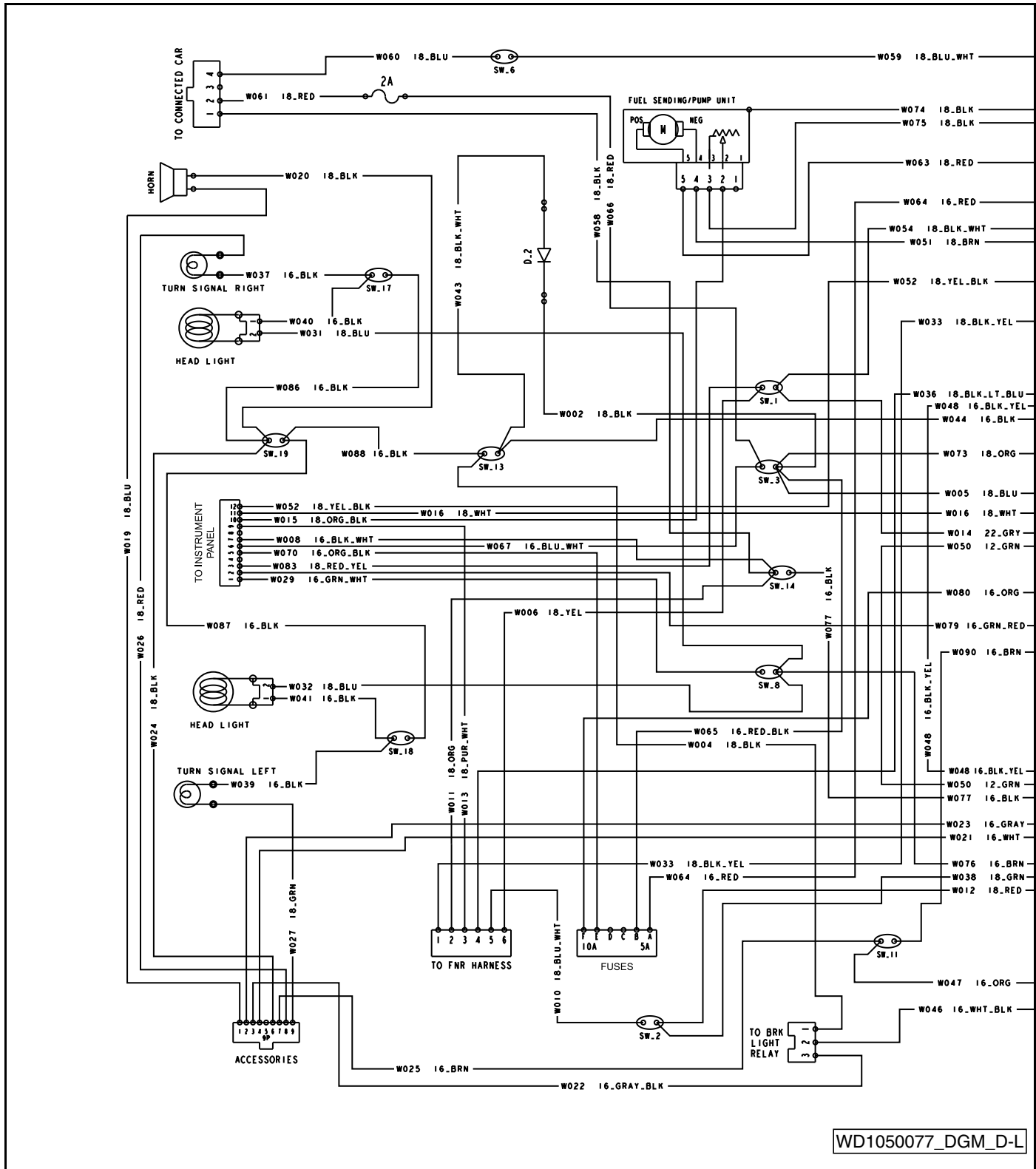

Figure 18-1 Wiring Diagram for Pedal-Start Gasoline Vehicle

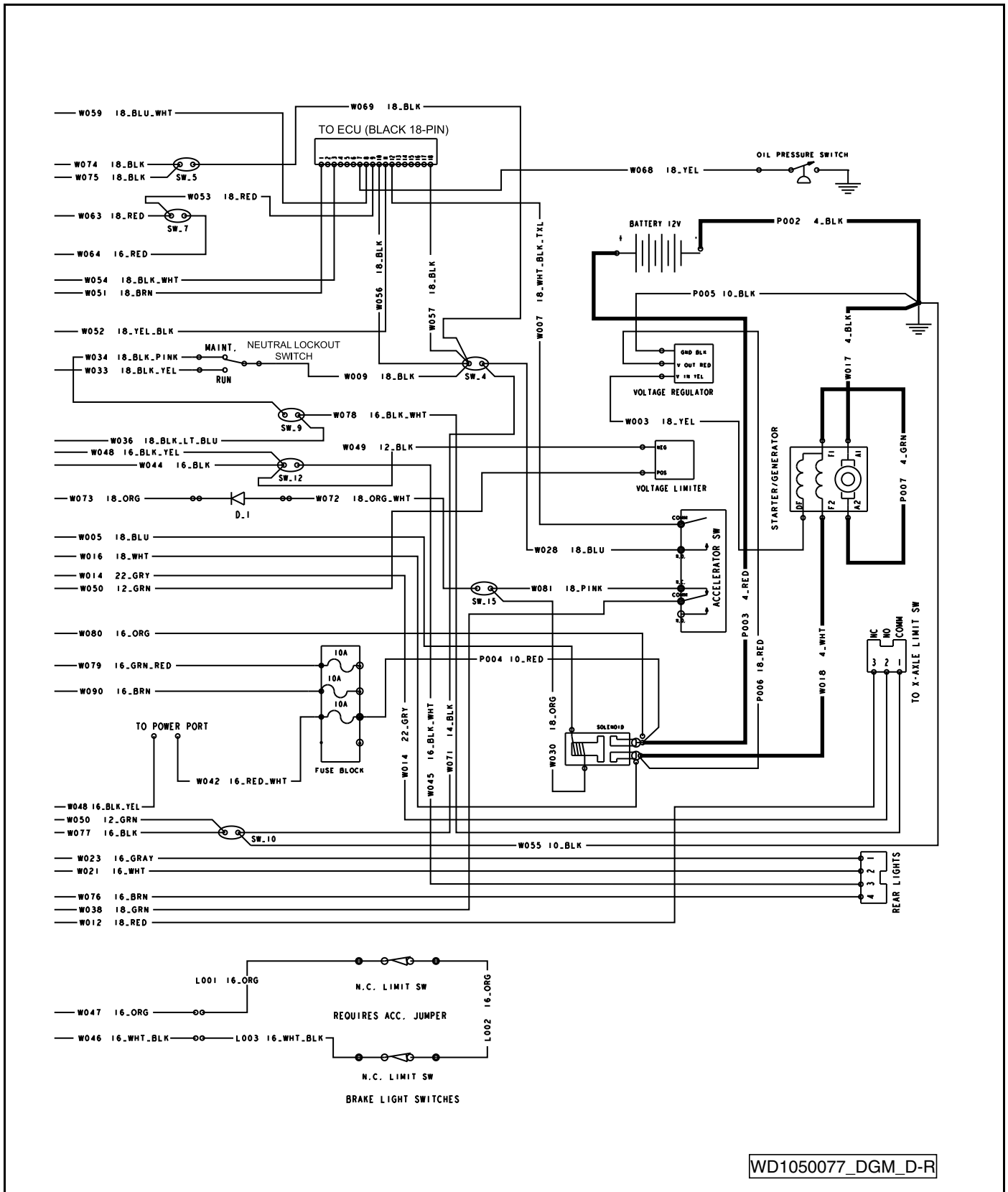

Figure 18-2 Wiring Diagram for Pedal-Start Gasoline Vehicle – Continued

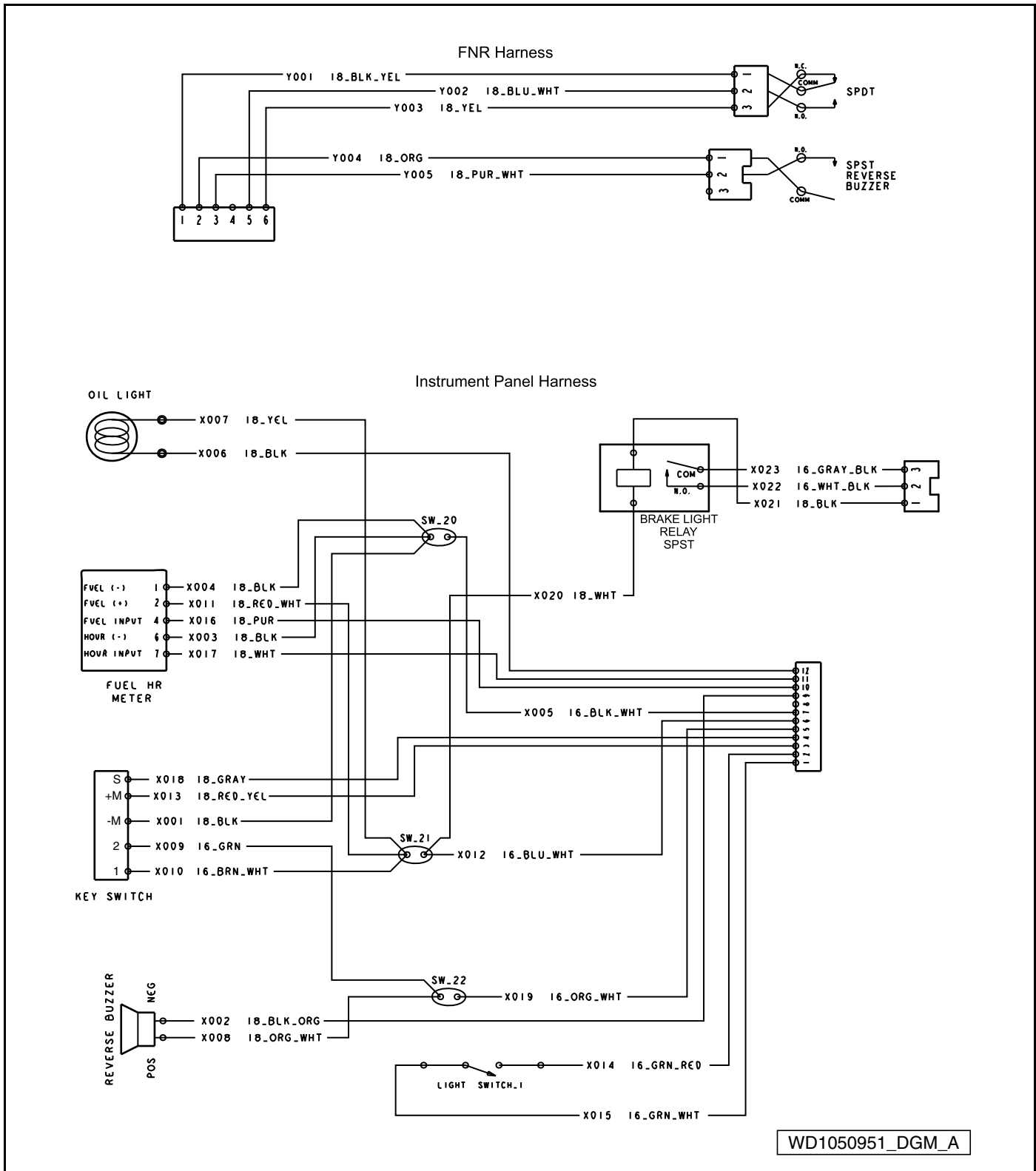

Figure 18-3 Wiring Diagram – Instrument Panel and FNR Shifter

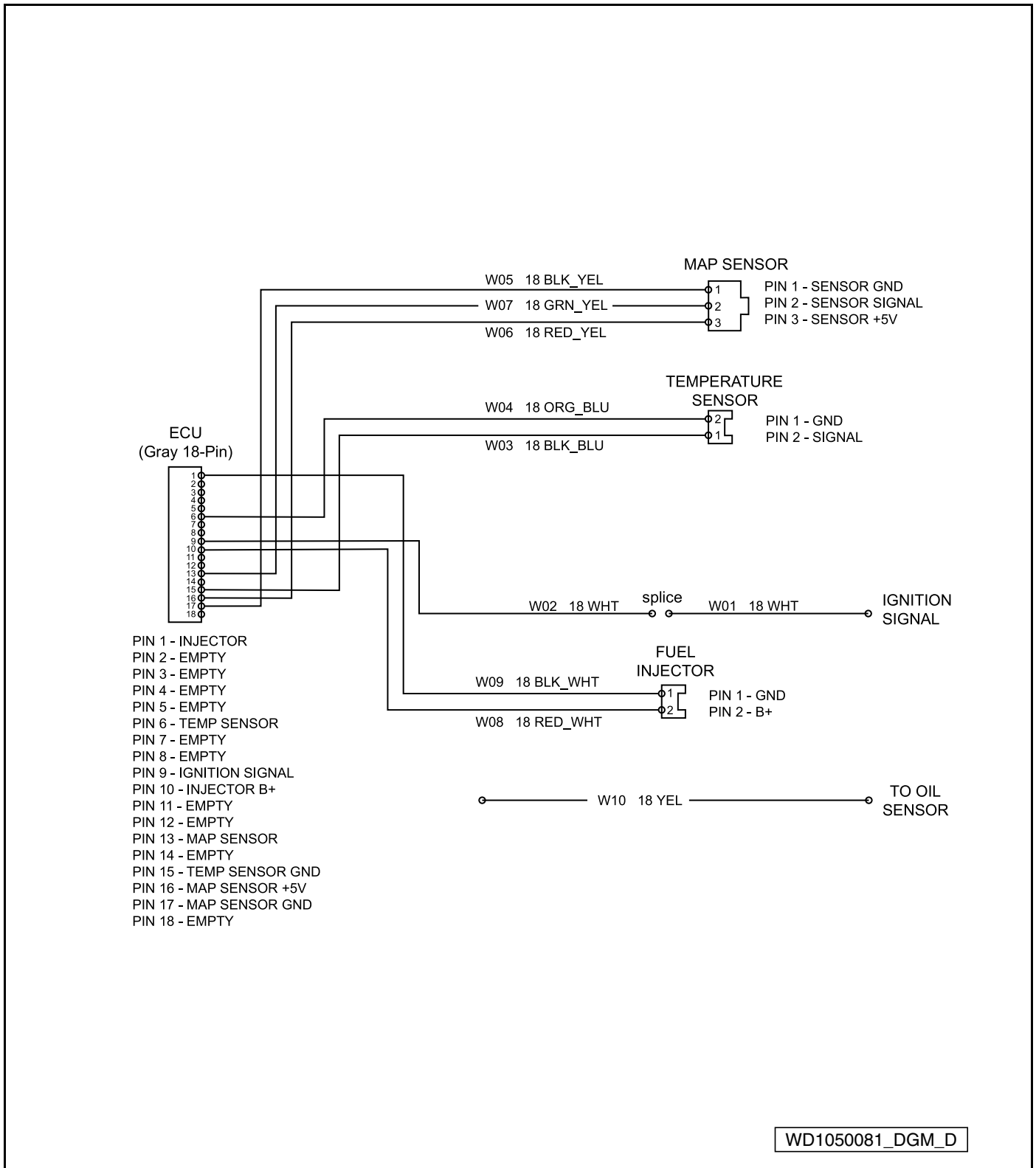
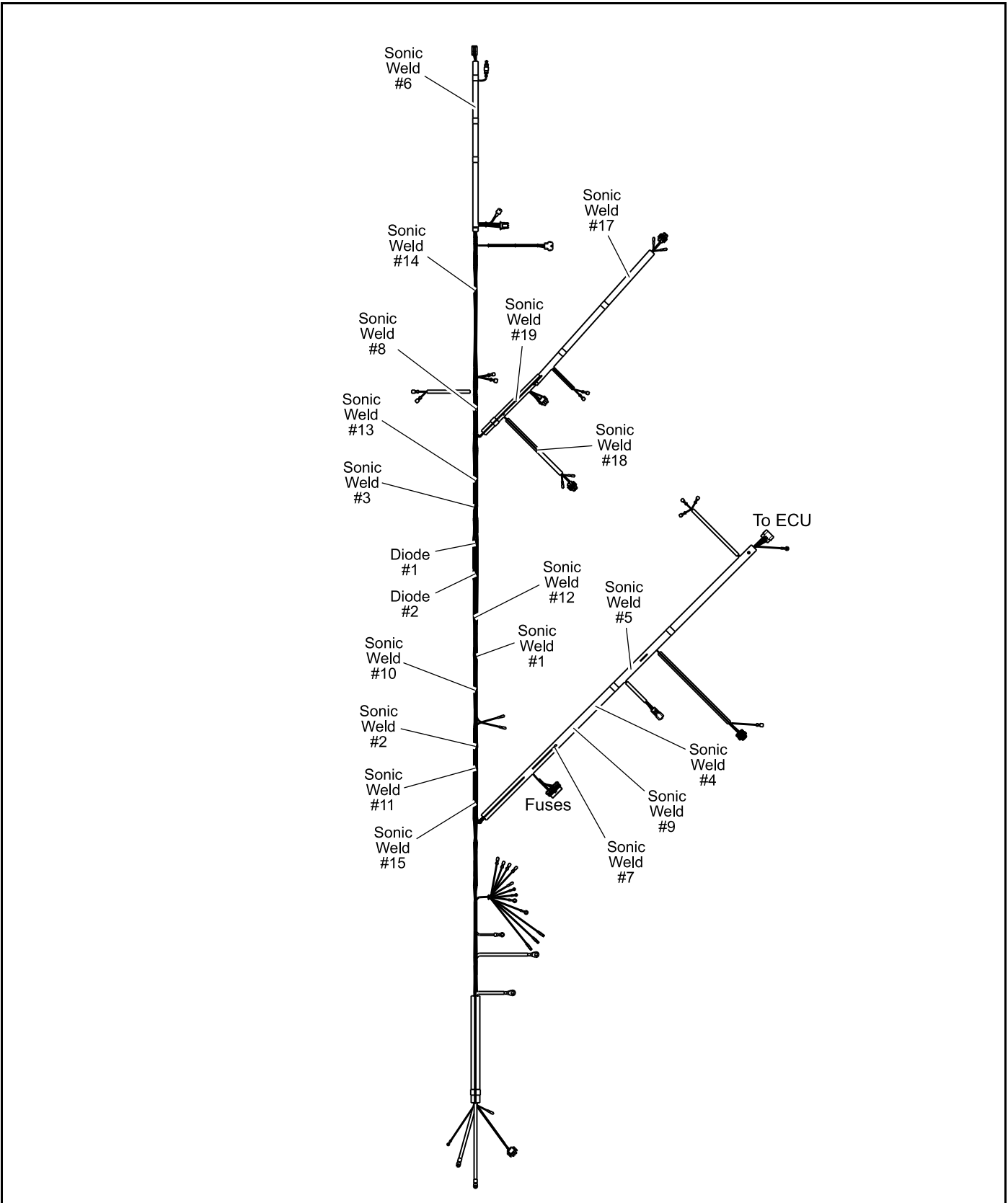
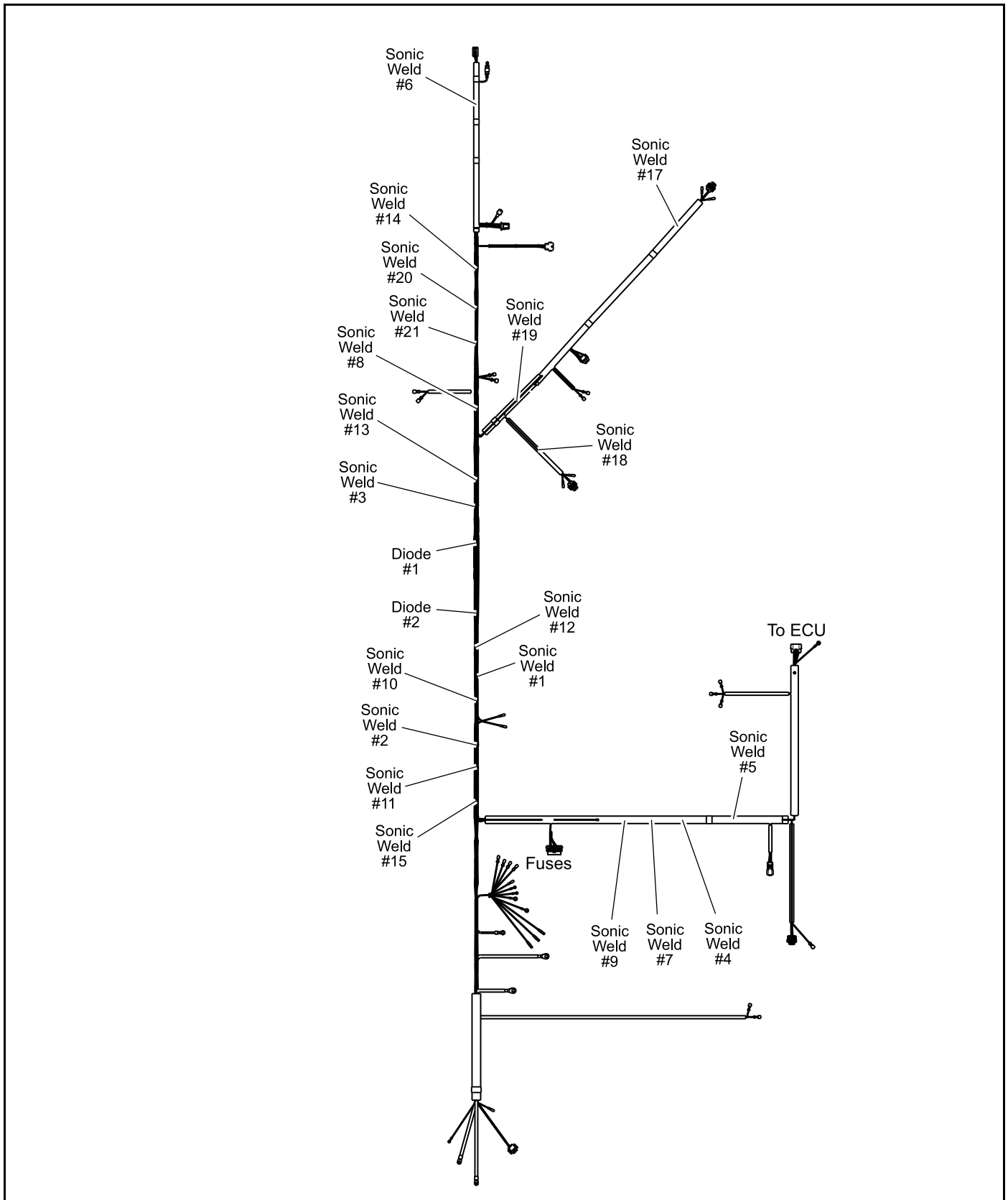

Figure 18-4 Wiring Diagram – EFI and Engine



3022

Figure 18-5 Sonic Weld and Diode Locations (Approximate) – CA500/550/Cafe Express



3020

Figure 18-6 Sonic Weld and Diode Locations (Approximate) – CA700

ELECTRICAL SYSTEM

The electrical system on the gasoline vehicle is 12 volts DC with negative (–) ground to frame, and consists of the following circuits that are easily identified:

- Starter Circuit
- Generator Circuit
- Electronic Fuel Injection Circuit
- Engine Ignition Circuit
- Engine Kill Circuit
- Reverse Buzzer Circuit
- Low Oil Warning Light Circuit
- Neutral Lockout Circuit
- Fuel Pump Circuit
- Fuel Gauge and Sending Unit Circuit
- Hour Meter Circuit
- Lighting Circuit

Recognizing and understanding the function of each of these circuits will help to quickly isolate the source of an electrical problem. Use the appropriate test procedure to correct the electrical problem. **See Test Procedures on page 18-15.**

For a complete wiring diagram, see Wiring Diagram for Pedal-Start Gasoline Vehicle on page 18-8 or Wiring Diagram for Key-Start Gasoline Vehicle on page 19-2.

TEST PROCEDURES

Using the following procedures, the entire electrical system can be tested without major disassembly of the vehicle.

⚠ WARNING

- If wires are removed or replaced, make sure wiring and wire harness is properly routed and secured. Failure to properly route and secure wiring could result in vehicle malfunction, property damage, personal injury, or death.

For some tests, the electrical component box cover must be removed to gain access to the various components that are mounted inside the component box. **See following WARNING.**

⚠ WARNING

- Shorting of battery terminals can cause personal injury or death.

After test procedures are completed, be sure to replace the cover. **See following CAUTION.**

CAUTION

- Exposure to water and the elements may damage electrical components. Do not operate vehicle without the cover properly installed.

TESTING BASICS

- Battery voltage will be referenced throughout the test procedures. Battery voltage is accessed in **Test Procedure 1 – Battery on page 18-17.**
- The MAINTENANCE/OPERATE switch, in the MAINTENANCE position, grounds and kills the ignition if the FNR shifter is placed in FORWARD or REVERSE.
- The key switch powers the ECU, fuel pump, solenoid, lights, and the connected car device.
- The 2-amp fuse is powered by the key switch via the 10-amp ATM fuse and carries battery voltage to the connected car device.
- The term “back-probe” refers to probing the side of a connector that the wire enters. This is usually done when the connector must remain connected to a device. An alternative method is to use an insulation-piercing probe. **See following CAUTION.**

CAUTION

- Be careful not to damage the wire or terminal when back-probing.
- When testing voltage, the battery must remain connected.
- When testing voltage, unless specifically directed to do otherwise in a procedure, connect the black (–) probe of the multimeter to chassis ground.
- When testing resistance or continuity, turn off power to the circuit being measured and discharge any capacitor(s). The presence of voltage can cause inaccurate readings.

Index of Test Procedures

1 – Battery

-
- 2 – Fuses
 - 3 – Ground Cables
 - 4 – EFI System (ECU and Sensors)
 - 5 – Key Switch (Start Circuit)
 - 6 – Key Switch (Engine Kill Circuit)
 - 7 – Accelerator Pedal Limit Switch – Pedal-Start Vehicles Only
 - 8 – Solenoid
 - 9 – Maintenance/Operate Switch – Pedal-Start Vehicles
 - 10 – Neutral Lockout Limit Switch – Pedal-Start Vehicles Only
 - 11 – Starter/Generator (Generator Function)
 - 12 – Starter/Generator (Starter Function)
 - 13 – Voltage Regulator
 - 14 – Kill Limit Switch – Pedal-Start Vehicles Only
 - 15 – Ignition Spark
 - 16 – Ignition Coil
 - 17 – Reverse Buzzer and Reverse Buzzer Limit Switch
 - 18 – Low Oil Warning Light (LED)
 - 19 – Oil Level Sensor
 - 20 – Battery Test (Under Load)
 - 21 – Fuel Pump
 - 22 – Fuel Level Sending Unit
 - 23 – Fuel Gauge
 - 24 – Hour Meter
 - 25 – Light Switch
 - 26 – Voltage at Headlight Socket
 - 27 – Voltage Limiter
 - 28 – 4-Pin Connector (for Connected Car Device)

TEST PROCEDURE 1 – Battery

See General Warnings on page 1-1.

DANGER

- Due to the danger of an exploding battery, wear a full face shield and rubber gloves when working near a battery.
- Battery – Explosive gases! Do not smoke. Keep sparks and flames away from the vehicle and service area. Ventilate when charging or operating vehicle in an enclosed area. Wear a full face shield and rubber gloves when working on or near batteries.
- Battery – Poison! Contains acid! Causes severe burns. Avoid contact with skin, eyes, or clothing. Antidotes:
 - External: Flush with water. Call a physician immediately.
 - Internal: Drink large quantities of milk or water. Follow with milk of magnesia or vegetable oil. Call a physician immediately.
 - Eyes: Flush with water for 15 minutes. Call a physician immediately.

NOTE: The battery must be properly maintained and fully charged in order to perform the following test procedures. Battery maintenance procedures can be found in section **Electrical Components: Pedal-Start Gas Vehicle** on page 20-1 of this manual. See **Battery** on page 20-33.

1. Place the Forward/Reverse handle in the NEUTRAL position and the neutral lockout switch in the MAINTENANCE position. Chock the wheels.
2. Check for loose or corroded battery terminal connections. Remove the negative (–) cable first and clean, tighten, and replace connections as necessary.

Voltage Test

1. Take a voltage reading with a multimeter set to 20 VDC by placing the red (+) probe on the positive (+) battery post and the black (–) probe on the negative (–) battery post. If it shows less than 12.4 volts recharge the battery. If battery voltage is greater than 12.4 volts, the problem is not with the battery. If the battery does not reach 12.4 volts after charging, replace the battery. **See following NOTE.**

NOTE: Open circuit voltage should be at least 12.4 volts.

Load Test

1. Connect a 160-ampere load tester to the battery posts.
2. Turn the switch on the load tester to the ON position.
3. Read the battery voltage after the load tester has been turned ON for 15 seconds. Compare the battery's voltage reading with the following table. Make sure you have the correct ambient temperature.

IF TEMPERATURE IS	MINIMUM CRANKING VOLTAGE
70 °F (20 °C and above)	9.6 V
60 °F (16 °C)	9.5 V
50 °F (10 °C)	9.4 V
40 °F (4 °C)	9.3 V
30 °F (-1 °C)	9.1 V
20 °F (-7 °C)	8.9 V
10 °F (-12 °C)	8.7 V
0 °F (-18 °C)	8.5 V

4. If the battery is found to be good, or if the electrical problem continues after the battery has been replaced with a good one, test the electrical circuits.

TEST PROCEDURE 2 – Fuses

See General Warnings on page 1-1.

⚠ WARNING

- Failure to use properly rated fuse can result in a fire hazard.

NOTE: These vehicles predominately use a combination of ATC-style and ATM-style blade fuses. A single ABC-style glass fuse is used for the Guardian/Visage 4-pin connector that is labeled "V3 circuit" on the harness.

This is a voltage test. It can be performed relatively easily on ATC-style and ATM-style fuses. A voltage test can be performed on the ABC-style glass fuse if insulation-piercing probes are used. Otherwise, the ABC-style will have to be removed to visually inspect or check using a continuity test.

ATC-style blade fuses are located inside the electrical component box near the battery.

ATM-style blade fuses are located on the main wire harness in front of the engine.

The ABC-style glass fuse is located on the main wire harness underneath the front cowl.

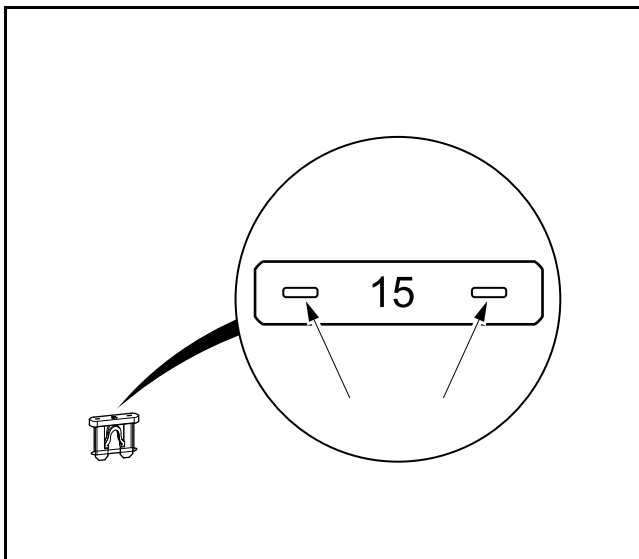

2784

Figure 18-7 Testing the ATC and ATM-style Blade Fuse

1. If necessary, see Testing Basics on page 18-15.
2. Access the fuse but do not remove it.
3. **10-amp ATC and ATM Fuses Only:** With the battery and solenoid connected:
 - 3.1. Probe the two, small metal contacts on the top of the fuse (**Figure 18-7, Page 18-19**).
 - 3.2. Each contact should show battery voltage.
 - 3.3. If only one side shows battery voltage, replace fuse.
 - 3.4. If neither side of a fuse shows battery voltage, inspect the following locations:
 - Wire connections at the solenoid.

4. **5-amp ATM Fuse Only:** With the key switch in the ON position:
 - 4.1. Probe the two, small metal contacts on the top of the fuse (**Figure 18-7, Page 18-19**).
 - 4.2. Each contact should show battery voltage.
 - 4.3. If only one side shows battery voltage, replace fuse.
 - 4.4. If neither side of a fuse shows battery voltage, inspect the following locations:
 - 12-pin dash wire harness connector, key switch and sonic weld 3.
5. **2-amp ABC Glass Fuse Only:** With the key switch in the ON position:
 - 5.1. Probe the wire on each side of the fuse with insulation-piercing probes.
 - 5.2. Each probe should show battery voltage.
 - 5.3. If only one side shows battery voltage, replace fuse.
 - 5.4. If neither side of a fuse shows battery voltage, inspect the following locations:
 - 5-amp ATM fuse, 12-pin dash wire harness connector, key switch and sonic weld 3.

TEST PROCEDURE 3 – Ground Cables

See General Warnings on page 1-1.

NOTE: This is a continuity test for the main ground wire(s) of the vehicle. An additional ground wire is located on top of the fuel tank.

1. If necessary, see Testing Basics on page 18-15.
2. Disconnect battery and spark plug wire(s). See **Disconnecting the Battery-Gasoline Vehicles on page 1-5.**
3. Check the following wires and cables for clean, tight connections and continuity (**Figure 18-8, Page 18-21**):
 - Check the starter/generator ground cable (black wire) from A1 terminal to chassis.
 - Check the battery ground cable from the disconnected terminal to chassis.
 - Check the engine ground cable from engine block to chassis.
4. The reading should be continuity. If the reading is incorrect, clean and tighten cable connections. If the connections are good and the reading is incorrect, repair or replace the wire or cable.

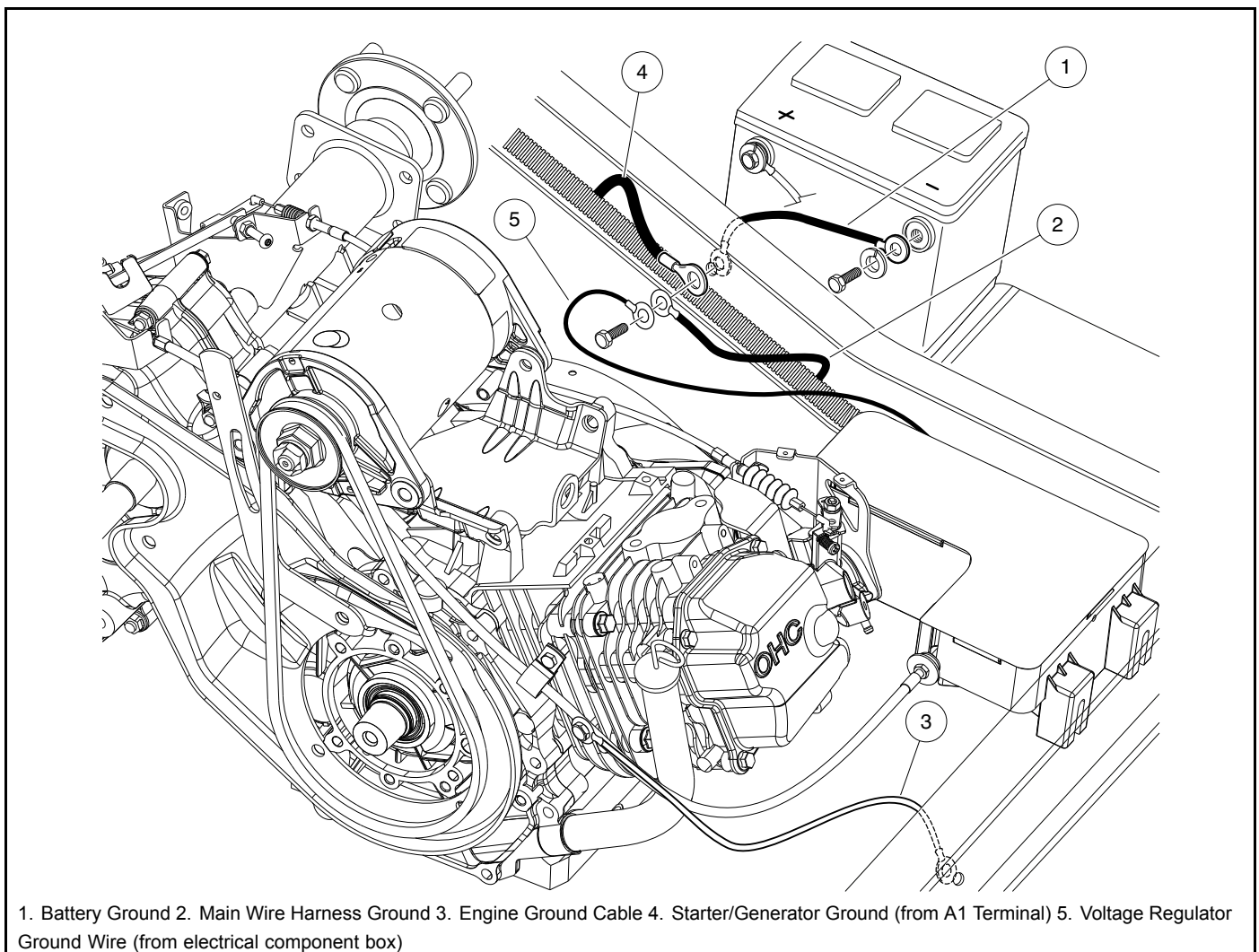

3023

Figure 18-8 Ground Wires and Cables

TEST PROCEDURE 4 – EFI System (ECU and Sensors)

See General Warnings on page 1-1.

WARNING

- This procedure involves testing voltage, resistance and continuity. If necessary, see Testing Basics on page 18-15.

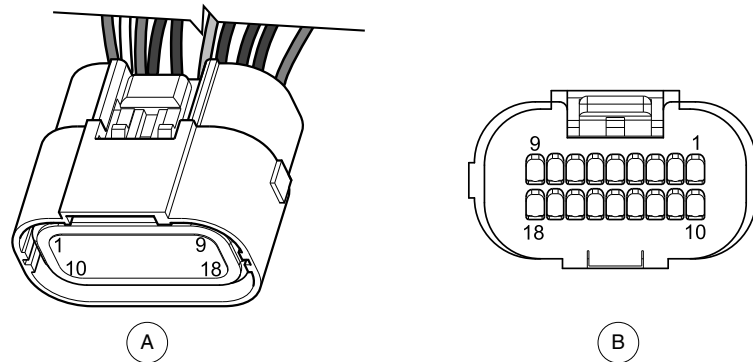

18-PIN CONNECTOR (GRAY AND BLACK): A. ECU SIDE OF CONNECTOR B. WIRE ENTRY SIDE OF CONNECTOR

PIN I.D.	CONNECTOR COLOR	FUNCTION	TEST TYPE & PROBE BETWEEN LOCATIONS	TEST RESULT	CONDITION
1	Gray	Fuel Injector Control	Resistance: ECU Gray Pin 1 (Black/White) and ECU Gray Pin 10 (Red/White)	Approx. 12 ohms	Key OFF or ON
6	Gray	Engine Temperature Sensor Input	Resistance: ECU Gray Pin 6 (Orange/Blue) and ECU Gray Pin 15 (Black/Blue)	Approx. 11.5 kOhms @ 70 °F (21 °C) Resistance decreases as temperature rises.	Key OFF
9	Gray	Ignition Coil Input	Resistance: ECU Gray Pin 9 (White) and Ground	Approx. 10.1 kOhms	Key OFF
10	Gray	Fuel Injector Positive (+) Voltage from ECU	Voltage: ECU Gray Pin 10 (Red/White) and Ground	Battery Voltage	Plug connected to ECU and Key ON
13	Gray	MAP Sensor Input	Voltage: ECU Gray Pin 13 (Green/Yellow) and Ground	Approx. 3.9 volts @ sea level & engine OFF / 3.0 volts engine running. Voltage decreases as pressure decreases.	Key ON and engine running
15	Gray	Engine Temperature Sensor Ground	Continuity: ECU Gray Pin 15 (Black/Blue) and Ground	Meter should beep	Key OFF
16	Gray	MAP Sensor Reference Voltage (+5)	Voltage: ECU Gray Pin 16 (Red/Yellow) and ECU Gray Pin 17 (Black/Yellow)	Approx. 5 volts	Key ON
17	Gray	MAP Sensor Ground	Continuity: ECU Gray Pin 17 (Black/Yellow) and Ground	Meter should beep	Key OFF
			Voltage: ECU Gray Pin 17 (Black/Yellow) and Battery (+) Terminal	-Battery Voltage	Key OFF
1	Black	Fuel Pump Input	Voltage: ECU Black Pin 1 (Brown) and ECU Black Pin 10 (Black)	Battery Voltage (after pump stops running)	Key ON

TABLE CONTINUED ON NEXT PAGE

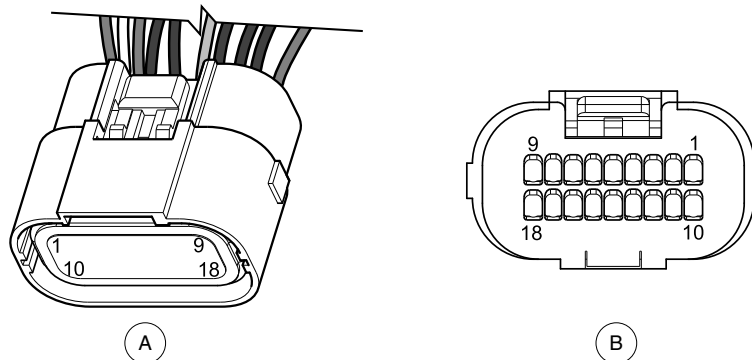

18-PIN CONNECTOR (GRAY AND BLACK): A. ECU SIDE OF CONNECTOR B. WIRE ENTRY SIDE OF CONNECTOR

PIN I.D.	CONNECTOR COLOR	FUNCTION	TEST TYPE & PROBE BETWEEN LOCATIONS	TEST RESULT	CONDITION
3	Black	Ignition OFF Input	Continuity: ECU Black Pin 3 (Black/White) and Ground	Meter should beep	Key OFF
				Meter should NOT beep	Key ON
7	Black	Low Oil Sensor Input	Resistance: ECU Black Pin 7 (Yellow) and Ground	Approx. 2.3 kOhms	Key OFF
8	Black	Connected Car Link	Voltage: ECU Black Pin 8 (Blue/White) and Ground	11.8 volts	Key ON
9	Black	B+ Input	Voltage: ECU Black Pin 9 (Red) and ECU Black Pin 10 (Black)	Battery Voltage	Key ON
10	Black	Ground for ECU Power	Continuity: ECU Black Pin 10 (Black) and Ground Voltage: ECU Black Pin 10 (Black) and Battery (+) Terminal	Meter should beep	Key OFF
				-Battery Voltage	Key OFF
11	Black	Diagnosis (low oil) Lamp Control	Voltage: ECU Black Pin 11 (Yellow/Black) and Ground	Less than 1 Volt initially. 7 to 8 volts after lamp is OFF.	Key ON
12	Black	Foot Input	Continuity: ECU Black Pin 12 (White/Black) and Black Pin 18 (Black)		Key OFF with:
				Meter should beep	Accel. Pedal UP
				Infinity	Accel. Pedal DOWN
18	Black	Ground for ECU Housing	Continuity: ECU Black Pin 18 (Black) and Ground Voltage: ECU Black Pin 18 (Black) and Battery (+) Terminal	Meter should beep	Key OFF
				-Battery Voltage	Key OFF

TEST PROCEDURE 5 – Key Switch (Start Circuit)

See General Warnings on page 1-1.

NOTE: *This is a voltage test.*

The key switch provides power and KEY INPUT to the ECU.

1. If necessary, see Testing Basics on page 18-15.
2. Remove instrument panel to access the back of the key switch but do not disconnect wires. **See Instrument Panel Removal on page 4-10.**
3. With the key switch in the OFF position:
 - The green wire should show battery voltage coming to the switch.
 - The brown/white wire should show zero (0) volts. If it shows battery voltage, the switch has failed CLOSED and must be replaced.
4. With the key switch in the ON position:
 - The brown/white wire should show battery voltage passing through the key switch to sonic weld 3, the 5-amp fuse, the solenoid, and the 4-pin connected car plug. If it does not show battery voltage, the switch has failed OPEN and must be replaced.

TEST PROCEDURE 6 – Key Switch (Engine Kill Circuit)

See General Warnings on page 1-1.

NOTE: This is a continuity test.

1. If necessary, see Testing Basics on page 18-15.
2. Disconnect battery and spark plug wire(s). See **Disconnecting the Battery-Gasoline Vehicles on page 1-5**.
3. Remove the instrument panel. See **Instrument Panel Removal on page 4-10**.
4. Disconnect wires from the (+M) and (–M) terminals of the key switch (**Figure 18-9, Page 18-26**).
5. Place the red (+) probe on the (+M) terminal and the black (–) probe on the (–M) terminal. With the key switch OFF, the reading should be continuity. With the key switch ON, the reading should be no continuity. If either reading is incorrect, replace the key switch.
6. Connect wires to the key switch. Make sure wires are connected correctly and are tight. If they are not, rewire or tighten as necessary.
7. Install dash panel in reverse order of removal.

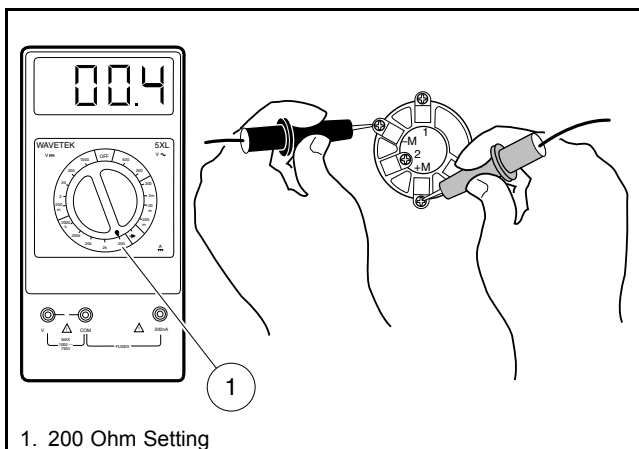

1337

Figure 18-9 Key Switch Test – Engine Kill Circuit

TEST PROCEDURE 7 – Accelerator Pedal Limit Switch – Pedal-Start Vehicles Only

See General Warnings on page 1-1.

NOTE: This is a continuity test.

The accelerator pedal limit switch is the top switch located in the electrical component box. There is a green wire and a pink wire connected to this limit switch.

1. If necessary, see Testing Basics on page 18-15.
2. Disconnect battery and spark plug wire(s). See **Disconnecting the Battery-Gasoline Vehicles on page 1-5**.
3. Check for proper wiring and tight connections (**Figure 18-1, Page 18-8**).
4. Set the multimeter to 200 ohms. Place the red (+) probe on the common (COM) terminal (green wire) of the limit switch and place the black (–) probe on the normally closed (NC) terminal (pink wire) of the limit switch.
5. Make sure the battery is disconnected. With the key switch in the OFF position, the Forward/Reverse handle in NEUTRAL, and the accelerator pedal in the UP position, the reading should be no continuity. With the accelerator pedal pressed, the reading should be continuity. If readings are incorrect, replace the switch.

TEST PROCEDURE 8 – Solenoid

See General Warnings on page 1-1.

NOTE: This is a resistance and voltage test.

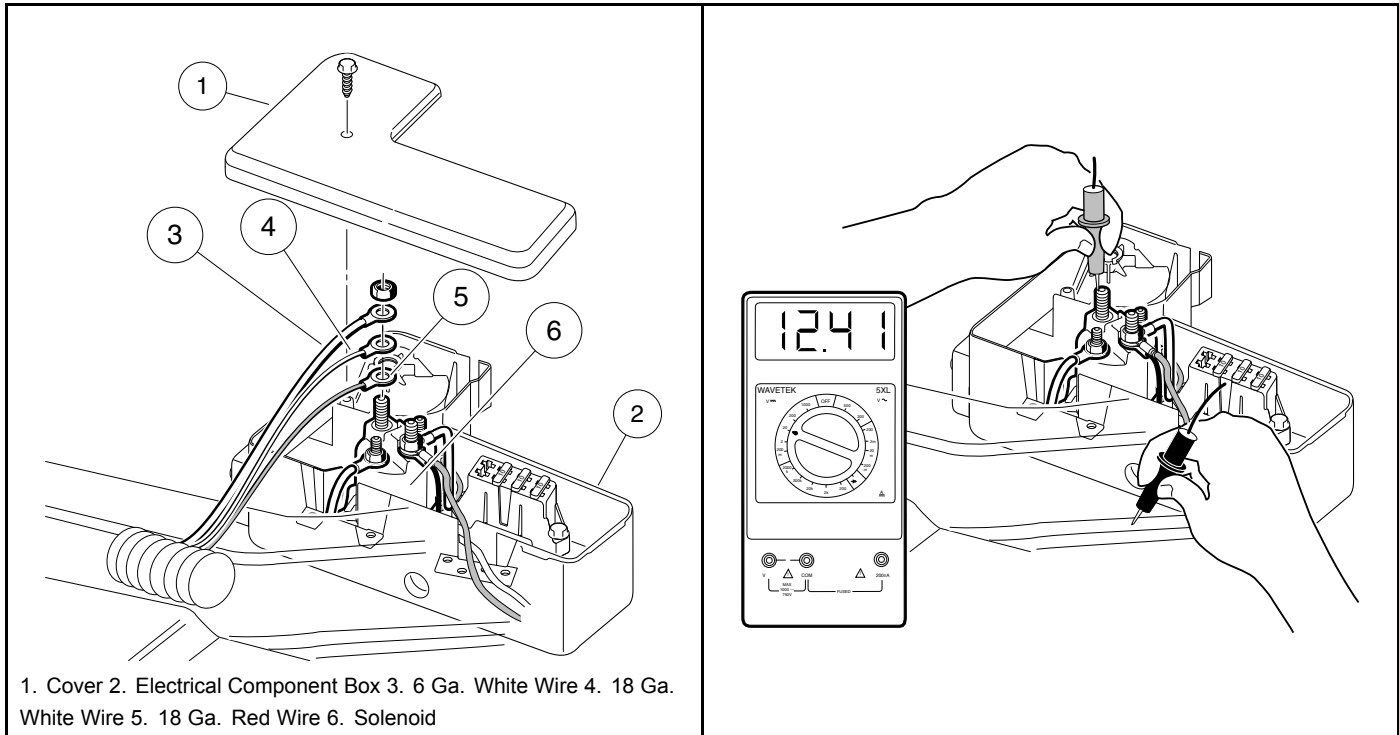

1. Cover 2. Electrical Component Box 3. 6 Ga. White Wire 4. 18 Ga. White Wire 5. 18 Ga. Red Wire 6. Solenoid

3025

Figure 18-10 Solenoid Wire Removal

3027

Figure 18-11 Solenoid Voltage Test

1. If necessary, see Testing Basics on page 18-15.
2. Remove the electrical component box cover.
3. Ensure that the wires are connected correctly and are tight. If they are not, rewire or tighten as necessary.
4. **Coil Side:** Check resistance across the small posts of the solenoid. The reading should be 14 to 16 ohms. If the reading is not within limits, replace the solenoid.
5. **Contact Side:** Remove the 6-gauge white wire, the 16-gauge red wire, and 16-gauge white wire from the large post of the solenoid. Do not allow the wires to touch the frame or other components of the vehicle (**Figure 18-10, Page 18-27**). Cover the other large post.
 - 5.1. Place Forward/Reverse handle in the NEUTRAL position, neutral lockout switch in the MAINTENANCE position, and key switch in the ON position.
 - 5.2. Check voltage between the empty large post and ground (**Figure 18-11, Page 18-27**).
 - **With accelerator pedal in the UP position:** The meter should read no voltage.
 - **With accelerator pedal pressed:** The solenoid should click and the meter should read battery voltage.
 - 5.3. If the readings are incorrect, replace solenoid. **See Solenoid Removal, Section 20, Page 20-20.**

TEST PROCEDURE 9 – Maintenance/Operate Switch – Pedal-Start Vehicles

See General Warnings on page 1-1.

NOTE: This is a continuity test.

The Maintenance/Operate Switch is also known as the Neutral Lockout Switch.

1. If necessary, see Testing Basics on page 18-15.
2. Remove wires from switch (**Figure 18-12, Page 18-28**).
3. With switch in position 1 (MAINTENANCE):
 - 3.1. Check for no continuity between terminals T1 and T2.
 - 3.2. Check for continuity between terminals T2 and T3.
4. With switch in position 2 (OPERATE):
 - 4.1. Check for no continuity between terminals T2 and T3.
 - 4.2. Check for continuity between terminals T1 and T2.

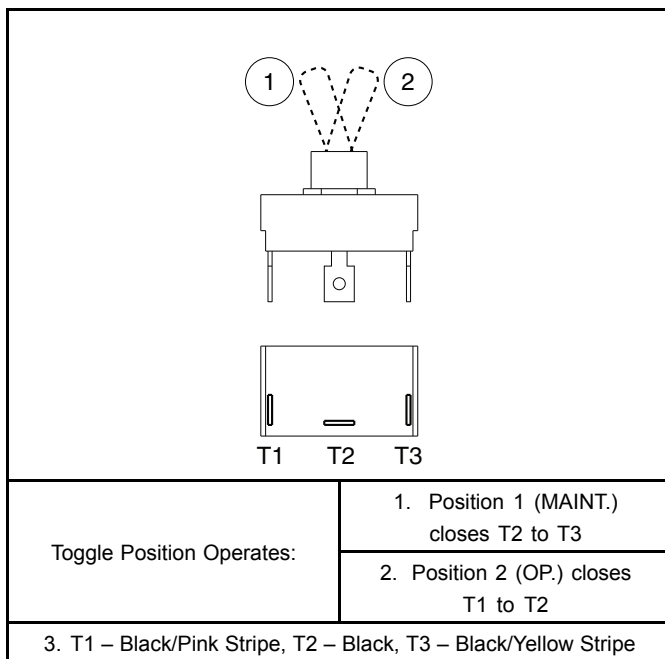

⁴⁷⁸
Figure 18-12 Maintenance/Operate Switch Test – for Pedal-Start Vehicles

5. If switch:
 - 5.1. does not work as stated in previous steps, replace switch.
 - 5.2. does work as stated and the MAINTENANCE/OPERATE modes still do not work:
 - Check the limit switches.
 - Check continuity of the wires involved.

TEST PROCEDURE 10 – Neutral Lockout Limit Switch – Pedal-Start Vehicles Only

See General Warnings on page 1-1.

NOTE: This is a continuity test.

This switch is located on the transaxle. A black/white wire, a gray wire, and a red wire are connected to this limit switch with a 3-pin connector.

1. If necessary, see Testing Basics on page 18-15.
2. Disconnect battery and spark plug wire(s). **See Disconnecting the Battery-Gasoline Vehicles on page 1-5.**
3. At transaxle, disconnect neutral lockout limit switch three-wire lead from main wire harness.
4. Check to be sure the cam lobe on the shift lever is pressing the neutral lockout limit switch as the Forward/Reverse shifter is being shifted. The limit switch should make an audible click as it is pressed. If it does not, check for wear on the cam lobe and replace shift lever if necessary.
5. Check the following terminals for no continuity with the lever released and continuity with the lever engaged (**Figure 18-13, Page 18-29**):

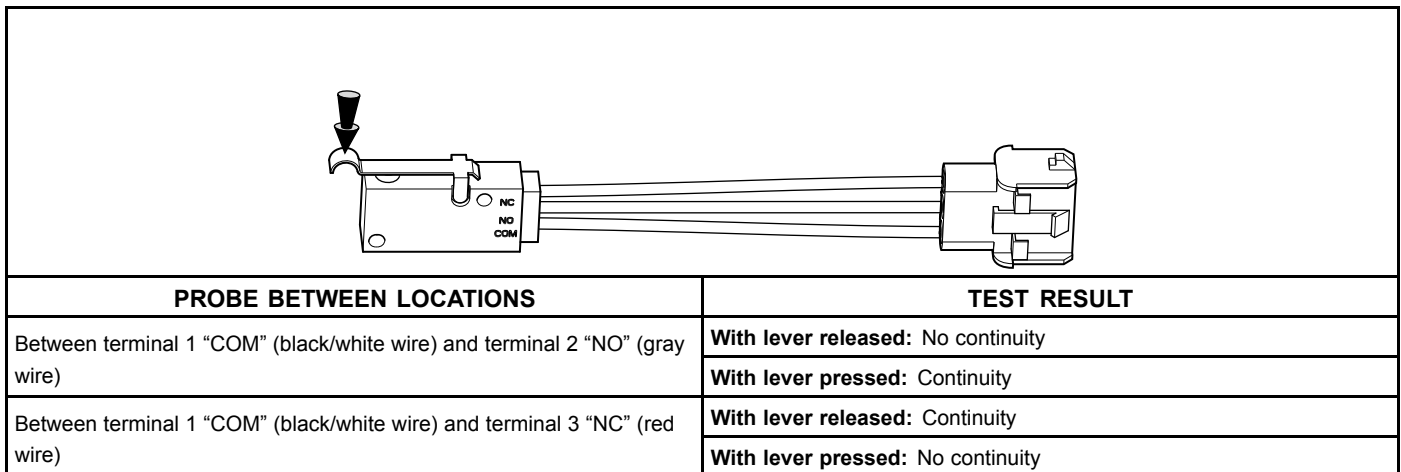

3028

Figure 18-13 Neutral Lockout Limit Switch Test

6. If switch does not work as stated in previous step, replace switch. **See Neutral Lockout Limit Switch Removal, Section 20, Page 20-19.**

TEST PROCEDURE 11 – Starter/Generator (Generator Function)

See General Warnings on page 1-1.

NOTE: This is a voltage test.

1. If necessary, see Testing Basics on page 18-15.
2. Place the Forward/Reverse handle in the NEUTRAL position and the neutral lockout switch in the MAINTENANCE position. Chock the wheels.
3. Ensure that the wires are connected correctly and are tight. If they are not, rewire or tighten as necessary.
4. Disconnect yellow wire from DF terminal on starter/generator. Cover terminal on yellow wire to make sure it will not short to ground. Then, using a jumper wire, ground DF terminal to A1 terminal (**Figure 18-14, Page 18-30**).
5. Using a multimeter set to 20 volts DC, place the red (+) probe on the positive (+) post of the battery, and place the black (-) probe on the negative (-) post. Start the engine and run it at full governed speed. The reading should show the voltage rising on the meter. If the voltage rises above 15.3 volts DC, test the voltage regulator. **See Voltage Regulator on page 18-32.** If the voltage does not rise, a tear-down inspection of the starter/generator will be necessary. **See Starter/Generator Removal on page 20-1.**
6. Remove jumper wire.
7. Reconnect yellow wire to DF terminal on starter/generator.

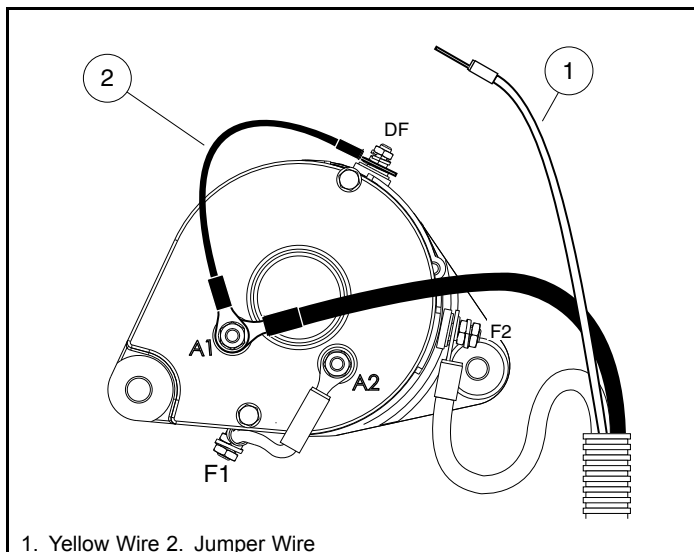

3029

Figure 18-14 Jumper Wire Ground – DF to A1

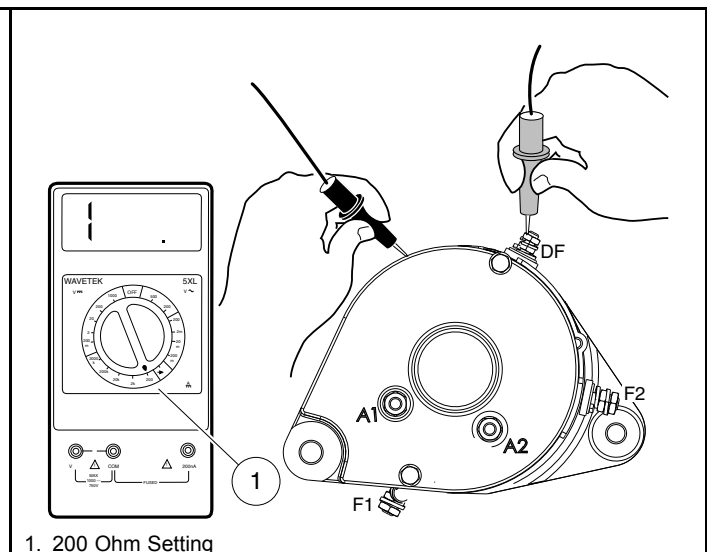

3030

Figure 18-15 Check Starter Terminal Continuity

TEST PROCEDURE 12 – Starter/Generator (Starter Function)

See General Warnings on page 1-1.

NOTE: Observe the following before testing the starter/generator:

- This is only testing continuity.
- Tag the starter/generator wires for identification before disconnecting.
- Remove starter/generator wire from one of the “A” terminals and one of the “F” terminals if testing while starter/generator is in vehicle.

- When disconnecting wires from starter/generator terminals, use a second wrench on the lower nut of the terminal post to hold post steady.
- Scrape a small amount of paint from starter/generator housing (ground) and use this location when testing motor terminals to electrical ground.

MOTOR TERMINALS	CONTINUITY TEST RESULT
A1 to A2 F1 to F2	Continuity
A1 to F1 A1 to F2	No Continuity
A2 to F1 A2 to F2	No Continuity
A1 to Ground A2 to Ground	No Continuity
F1 to Ground F2 to Ground	No Continuity

1. If necessary, see Testing Basics on page 18-15.
2. Disconnect battery and spark plug wire(s). **See Disconnecting the Battery-Gasoline Vehicles on page 1-5.**
3. Disconnect the wires from all the terminals on the starter/generator. Then place the black (–) probe of a multimeter, set to 200 ohms, on the starter/generator housing (scratch through the finish to ensure a good ground). While holding the black (–) probe against the housing, place the red (+) probe (one at a time) on the A1, A2, F1, F2 and DF terminals respectively (**Figure 18-15, Page 18-30**). The readings should be no continuity. If the readings are incorrect, the starter/generator will need to be removed from the vehicle and disassembled by a qualified technician. **See Starter/Generator Removal on page 20-1.**
 - An incorrect reading from the A1 or A2 terminal indicates three possible problems: 1) a grounded A1 or A2 terminal, 2) a grounded wire in the brush area, or 3) a grounded armature/commutator.
 - If the F1 or F2 reading is incorrect, it indicates a possible grounded F1 or F2 terminal or a grounded field coil.
 - If the DF reading is incorrect, it indicates a possible grounded DF terminal or a grounded field coil.
4. Using a multimeter set to 200 ohms, place the red (+) probe on the A1 terminal and the black (–) probe on the A2 terminal. The reading should be continuity. If the reading is incorrect, a possible open or poor contact in a brush assembly and/or open armature windings may be the cause. The starter/generator will need to be removed from the vehicle and disassembled by a qualified technician. **See Starter/Generator Removal on page 20-1.**
5. With the wires still disconnected, using a multimeter set on 200 ohms, place the red (+) probe on the F1 terminal and the black (–) probe on the F2 terminal. The reading should be between approximately 0.1 and 0.3 ohms. If the reading is incorrect, a possible open field coil or bad connections at terminals may be the cause. The starter/generator will need to be removed from the vehicle and disassembled by a qualified technician. **See Starter/Generator Removal on page 20-1.**
6. With the wires still disconnected, using a multimeter set to 200 ohms, place the red (+) probe on the DF terminal and the black (–) probe on the F1 terminal. The reading should be between 4.5 and 5.5 ohms. If the reading is incorrect, a possible grounded DF terminal and/or grounded field coil may be the cause. The starter/generator will need to be removed from the vehicle and disassembled by a qualified technician. **See Starter/Generator Removal on page 20-1.**

Ensure that wires are connected correctly and are tight. If they are not, rewire or tighten as necessary.

TEST PROCEDURE 13 – Voltage Regulator

See General Warnings on page 1-1.

NOTE: This is a voltage test.

Keep the battery connected while performing this test procedure.

1. If necessary, see Testing Basics on page 18-15.
2. Place the Forward/Reverse handle in the NEUTRAL position and the neutral lockout switch in the MAINTENANCE position. Chock the wheels.
3. Ensure that the wires are connected correctly and are tight. If they are not, rewire or tighten as necessary.
4. Check the engine RPM setting to ensure that it is adjusted correctly. **See Engine RPM Adjustment on page 23-13.**
5. With the battery in good condition and fully charged, run the engine for several minutes to bring the voltage regulator to operating temperature.
6. Turn the key switch to the OFF position, killing the engine. Using a multimeter set to 20 volts DC, place the red (+) probe on the large post of the solenoid with the red wire from the voltage regulator attached. Place the black (-) probe on the negative (-) battery post (**Figure 18-16, Page 18-32**). Turn the key switch to the ON position. Press the accelerator to start the engine and run it at full governed speed. If the reading is between 14.7 and 15.3 volts, the regulator is good. If the reading is lower than 14.7 volts but rising steadily, check battery condition. **See Battery on page 18-17.** If the reading is lower than 14.7 volts and not rising, and the starter/generator is good; or if the reading is over 15.3 volts and continues to rise, replace voltage regulator. **See Voltage Regulator Removal on page 20-15.**

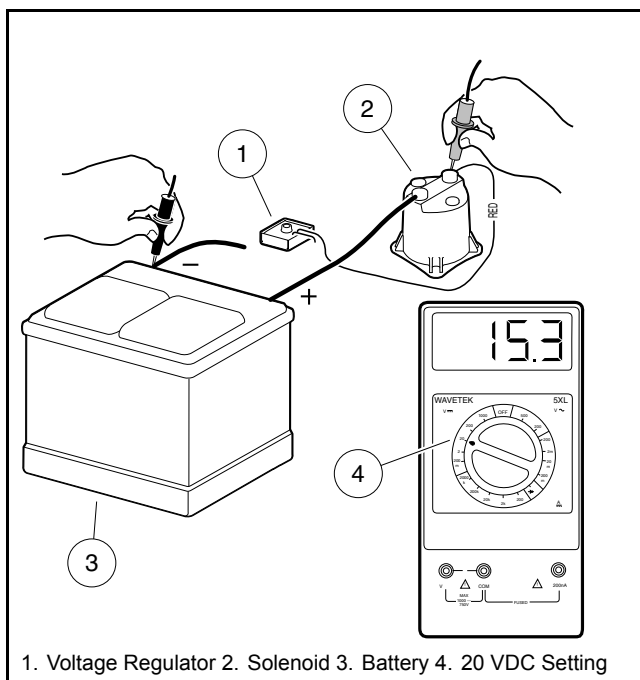

463

Figure 18-16 Voltage Regulator Test

TEST PROCEDURE 14 – Kill Limit Switch – Pedal-Start Vehicles Only

See General Warnings on page 1-1.

NOTE: This is a continuity test.

The kill limit switch is the lower of the two limit switches located in the electrical component box. There is a white/black wire and a blue wire connected to this limit switch.

1. If necessary, see Testing Basics on page 18-15.
2. Disconnect battery and spark plug wire(s). **See Disconnecting the Battery-Gasoline Vehicles on page 1-5.**
3. Remove the electrical component box cover.
4. Check for proper wiring and tight connections. **See Wiring Diagrams on page 18-8.**
5. Disconnect the wires from the lower of the two limit switches and test the limit switch for continuity.
 - Place the red (+) probe of the multimeter on the common (COM) terminal (white/black wire) of the limit switch. Place the black (–) probe on the normally open (NO) terminal (blue wire) of the limit switch. Without the lever pressed, the reading should be no continuity. Press the lever, and the reading should be continuity. If either reading is incorrect, replace the limit switch (**Figure 18-17, Page 18-33**).
6. Reconnect wires to limit switch.

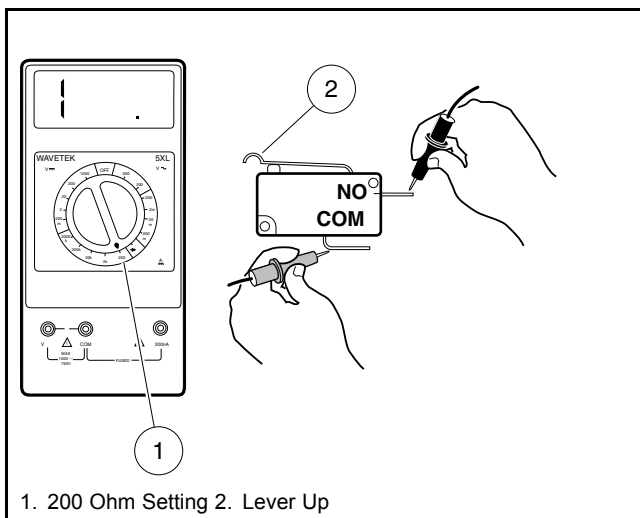

476

Figure 18-17 Kill Limit Switch Test

TEST PROCEDURE 15 – Ignition Spark

See General Warnings on page 1-1.

NOTE: Keep the battery connected while performing this test procedure.

1. If necessary, see Testing Basics on page 18-15.
2. Place the Forward/Reverse handle in the NEUTRAL position and the neutral lockout switch in the MAINTENANCE position. Chock the wheels.
3. Remove the plug wire from the spark plug. Using an ignition spark gap test tool (Thexton 404® or equivalent), check for correct spark (**Figure 18-18, Page 18-34**).
- 3.1. Adjust the tester probes to approximately 18,000 volts (18 kV) setting (SE – *Small Engine Setting* on the Thexton 404 tool). Connect the tester to the spark plug wire, and connect the alligator clip to a solid engine ground.
- 3.2. Start the engine. There should be a strong blue spark between the probes of the spark gap tester. If there is no spark, or if the spark is a faint yellow or red color, test components of the ignition circuit. **See Ignition Coil on page 18-35.**
4. If the spark gap tester tool indicates a strong blue spark, it is possible the spark plug has failed internally. Check the spark plug gap. The gap should be set at 0.024 to 0.028 in. (0.6 to 0.7 mm). If the gap is correct, replace the spark plug with a new part and test the engine for proper operation.

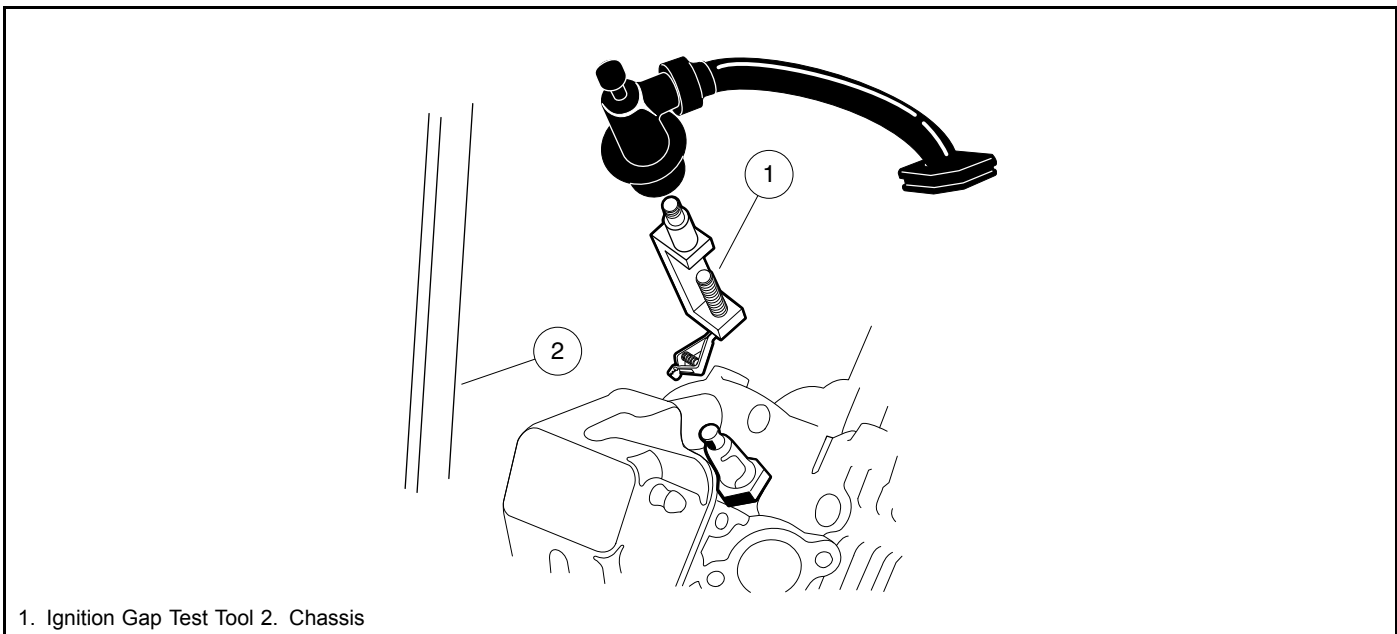

1. Ignition Gap Test Tool 2. Chassis

464

Figure 18-18 Ignition Spark Test

TEST PROCEDURE 16 – Ignition Coil

See General Warnings on page 1-1.

NOTE: This is a resistance test.

The following test procedures will properly detect a coil that has failed in most cases; however, in rare cases, some ignition coils can fail to operate at normal (warmer) operating temperatures. If the ignition coil has tested okay in the vehicle and on the bench, but fails to operate reliably, replace the coil with a known good coil and operate the engine for several minutes to ensure that the coil functions at normal operating temperature. If the new coil functions properly, keep the new coil in the circuit.

NOTE: Resistance value ranges given in these tests reflect a tolerance of $\pm 40\%$.

Please note that these values are rough standard and it is impossible to reach an exact conclusion with the resistance reading.

1. If necessary, see Testing Basics on page 18-15.
2. Disconnect battery and spark plug wire(s). **See Disconnecting the Battery-Gasoline Vehicles on page 1-5.**
3. At engine, access white wire in ECU wire harness that connects to ignition coil lead at back of engine.
4. Using a multimeter set to 200k ohms, measure resistance between the following locations listed in table below.

IGNITION COIL TERMINALS	TEST RESULT
White Signal Wire to Ground	9 to 11 kOhms
White Signal Wire to Spark Plug Cap	17 to 20 kOhms
Spark Plug Cap to Ground	8 to 13 kOhms

TEST PROCEDURE 17 – Reverse Buzzer and Reverse Buzzer Limit Switch

See General Warnings on page 1-1.

NOTE: Reverse Buzzer: This is a voltage test.

Reverse Buzzer Limit Switch: This is a continuity test.

A reverse buzzer is mounted on the back side of the instrument panel. On some models, another reverse buzzer is also mounted on a bracket at the left rear of the vehicle. The reverse buzzer is powered by the 10-amp ATM fuse located on the main wire harness in front of the engine.

The reverse buzzer limit switch is located on the Forward/Reverse shifter. Purple/white and orange wires are connected to it.

1. If necessary, see Testing Basics on page 18-15.
2. To test the front reverse buzzer, remove instrument panel. **See Instrument Panel Removal on page 4-10.**
3. Check for proper wiring and tight connections.
4. Check that battery voltage is present in the orange/white wire at buzzer.
5. Place the Forward/Reverse handle in the REVERSE position. The buzzer should sound. If not, check limit switch in the next steps.
6. Disconnect black/orange wire from buzzer.
7. With Forward/Reverse handle still in the REVERSE position, there should be continuity between the black/orange wire and ground. With Forward/Reverse handle still in the FORWARD position, there should be no continuity. If either reading is incorrect, replace limit switch. **See Reverse Buzzer Limit Switch Removal on page 20-25.**
8. If limit switch is operating properly, replace buzzer. **See Reverse Warning Buzzer Removal, Section 20, Page 20-23.**

TEST PROCEDURE 18 – Low Oil Warning Light (LED)

See General Warnings on page 1-1.

NOTE: This is a voltage test.

When the key switch is placed in the ON position, the Low Oil Warning Light will illuminate for approximately 3 seconds as a bulb check function.

1. If low oil warning light does not illuminate for approximately 3 seconds when the key switch is placed in the ON position, proceed with the steps below.
2. If necessary, see Testing Basics on page 18-15.
3. Remove the instrument panel. **See Instrument Panel Removal on page 4-10.**
4. Ensure that the wires are connected correctly and are tight. If they are not, rewire or tighten as necessary. **See Wiring Diagrams on page 18-8.**
5. With key switch in ON position, test for battery voltage at yellow wire to low oil warning light. If no voltage, check key switch. **See Key Switch (Start Circuit) on page 18-25.**
6. If battery voltage is present, use a test lead to ground the black wire terminal of low oil warning light. Light should illuminate. If not, replace low oil warning light.

TEST PROCEDURE 19 – Oil Level Sensor

See General Warnings on page 1-1.

NOTE: Keep the battery connected while performing this test procedure.

This procedure requires the oil to be drained from the engine.

1. If necessary, see Testing Basics on page 18-15.
2. Place the Forward/Reverse handle in the NEUTRAL position, the neutral lockout switch in the MAINTENANCE position, turn the key switch to the OFF position, disconnect the spark plug wire, and chock the wheels.
3. Ensure that the low oil warning light and all connecting wires are functioning correctly. **See Low Oil Warning Light (LED) on page 18-36.**
4. Drain the engine oil into an approved container and properly dispose of used oil.
5. Turn the key switch ON, closing the circuit. The low oil warning light should illuminate. If the low oil warning light does not illuminate, the oil level sensor needs to be replaced. **See Oil Level Sensor Removal on page 22-12.**
6. Fill the engine with new oil before returning the vehicle to service. **See Engine Oil – Gasoline Vehicle on page 22-2.**

TEST PROCEDURE 20 – Battery Test (Under Load)

See General Warnings on page 1-1.

NOTE: Keep the battery connected while performing this test procedure.

1. If necessary, see Testing Basics on page 18-15.
2. Place the Forward/Reverse handle in the NEUTRAL position and the neutral lockout switch in the MAINTENANCE position. Chock the wheels.
3. Set a multimeter to 20 volts DC and place the red (+) probe on the F2 (white wire) terminal on the starter/generator. Place the black (–) probe on the negative (–) battery post.
4. Turn the key switch to the ON position, leave the Forward/Reverse shifter in the NEUTRAL position and press the accelerator pedal (with the accelerator pedal pressed, the battery is under load).
 - 4.1. If the voltage reading is over 9.6 volts, with an electrolyte temperature of 70 °F (21 °C), check the starter/generator. **See following NOTE.**

NOTE: The voltage reading listed is for electrolyte at 70 °F (21 °C). At lower electrolyte temperatures the voltage reading will be lower.

5. If the reading is below 9.6 volts, with an electrolyte temperature of 70 °F (21 °C), check the battery. **See Battery on page 18-17.**
 - 5.1. If the reading is zero, there may be no continuity across the large posts of the solenoid. **See Solenoid on page 18-27.**
6. If all of the test results are good and the voltage reading is zero, there may be a broken or damaged 6-gauge white wire from the solenoid to the starter/generator. **See Starter/Generator (Starter Function) on page 18-30.**

TEST PROCEDURE 21 – Fuel Pump

See General Warnings on page 1-1.

⚠ WARNING

- To avoid the possibility of fire or explosion, make sure the fuel tank cap is securely in place while performing this test procedure.

NOTE: This is a voltage and resistance test.

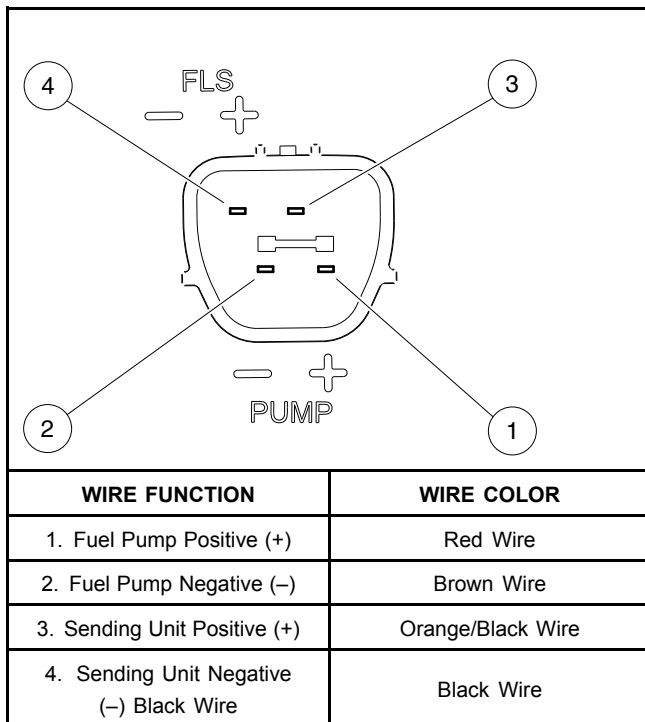

3031

Figure 18-19 Fuel Pump Module Terminals

Voltage to Pump

1. If necessary, see Testing Basics on page 18-15.
2. Disconnect the 5-pin connector from the top of the fuel pump module.
3. Check that battery voltage is present between ground and the red wire of the 5-pin connector immediately after the key switch is placed in the ON position.

NOTE: The fuel pump and low oil warning light operate for a few seconds when key switch is turned to the ON position; it stops if no engine RPM is detected by the ECU.

4. If no voltage, check key switch. **See Key Switch (Start Circuit) on page 18-25.**

Pump

1. If necessary, see Testing Basics on page 18-15.
2. Disconnect battery. **See Disconnecting the Battery-Gasoline Vehicles on page 1-5.**
3. Disconnect the 5-pin connector from the top of the fuel pump module.

4. Probe between pin (1) and pin (2) terminals in module (**Figure 18-19, Page 18-38**).
- 4.1. The reading should be approximately 2 to 5 ohms. If the reading indicates no resistance, the fuel pump has failed and the fuel pump module must be replaced. **See Fuel Pump Module Removal on page 23-18.**
- 4.2. If the reading is correct and the fuel pump does not function correctly, check the continuity of the red wire from the fuel pump to the red wire of the black 18-pin ECU connector. This red wire contains sonic weld 7. Leave the battery disconnected while checking continuity. Also, check the continuity of the brown wire from the fuel pump to the brown wire of the black 18-pin ECU connector. **See Fuel Gauge/Hour Meter Removal on page 20-27.**

TEST PROCEDURE 22 – Fuel Level Sending Unit

See General Warnings on page 1-1.

⚠ WARNING

- To avoid the possibility of fire or explosion, make sure the fuel tank cap is securely in place while performing this test procedure.

NOTE: This is a resistance test.

1. If necessary, see Testing Basics on page 18-15.
2. Disconnect battery. **See Disconnecting the Battery-Gasoline Vehicles on page 1-5.**
3. Disconnect the 5-pin connector from the top of the fuel pump module.
4. Probe between pin (3) and pin (4) terminals in module (**Figure 18-19, Page 18-38**).
5. The following resistance readings (in ohms) should be obtained depending on the position of the float inside the fuel tank. The resistance reading will vary according to the exact position of the float. The chart below may be used as a guideline to determine if the fuel level sending unit is operating correctly. Make sure the float is at the surface of the fuel in the tank.

FLOAT POSITION	RESISTANCE READING	FUEL GAUGE READINGS
Lower position (tank empty)	250 ohms (±10)	Empty
Center position (tank half full)	141 ohms (±8)	Half full
Upper position (tank full)	33.3 ohms (±6)	Full

6. If the readings are within the specifications listed above, the fuel level sending unit is working properly. If the readings are incorrect, the fuel level sending unit has failed and the fuel pump module must be replaced. **See Fuel Pump Module Removal on page 23-18.**
7. If the readings are correct and the fuel gauge does not function correctly, check the continuity of the orange/black wire from the fuel level sending unit to the purple wire on the fuel gauge/hour meter. Leave the battery disconnected while checking continuity. Also check the continuity of the red/white wire from the fuel gauge/hour meter to the brown/white wire on the key switch, and the black ground wires at the fuel level sending unit and at the fuel gauge/hour meter. **See Fuel Gauge/Hour Meter Removal on page 20-27.**
8. If the readings are correct according to the position of the float, but give an incorrect reading on the fuel gauge/hour meter, test the fuel gauge/hour meter. **See Fuel Gauge on page 18-40.**

TEST PROCEDURE 23 – Fuel Gauge

See General Warnings on page 1-1.

NOTE: This is a voltage test.

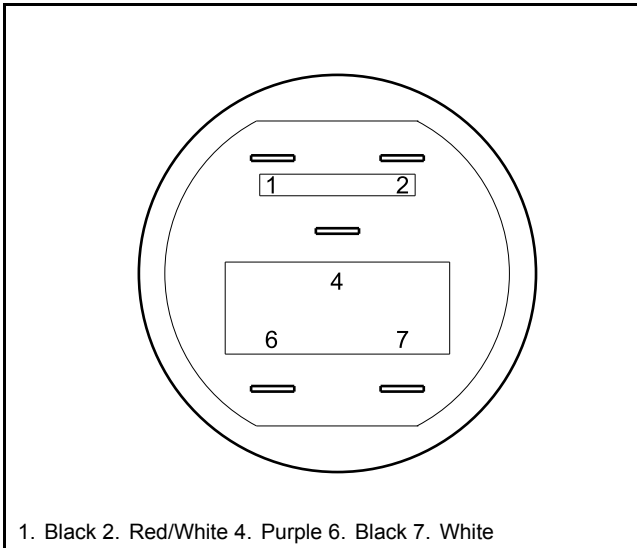

480

Figure 18-20 Fuel Gauge/Hour Meter

1. If necessary, see Testing Basics on page 18-15.
2. Turn the key switch OFF and remove the key. Place the Forward/Reverse handle in the NEUTRAL position. Chock the wheels.
3. Remove the instrument panel to gain access to the back of the fuel gauge/hour meter. **See Instrument Panel Removal on page 4-10.**
4. Place a sheet of insulating material between the front frame and the electrical connections on the rear of the instrument panel to prevent contact between the two.
5. Disconnect the purple wire from the fuel gauge/hour meter.
6. Set a multimeter to 20 volts DC and place the red (+) probe of the multimeter on the positive post of the battery. Place the black (-) probe on the negative post of the battery. Record the voltage reading.
7. Set a multimeter to 20 volts DC and place the red (+) probe on the (2) terminal of the fuel gauge/hour meter with the red/white wire is connected. Place the black (-) probe on the (1) terminal of the fuel gauge/hour meter with the black wire (**Figure 18-21, Page 18-41**).
8. Turn the key switch ON. The voltage reading should be the same as the battery voltage reading recorded earlier. If not, check the continuity of the red/white and black wires (**Figure 18-21, Page 18-41**).
9. The purple wire should remain disconnected for this step. Place the black probe of the multimeter on the (1) terminal of the fuel gauge/hour meter and place the red (+) probe on the (4) terminal of the fuel gauge/hour meter (**Figure 18-22, Page 18-41**). The voltage reading should be approximately 4.94 volts. If the reading is incorrect, replace the fuel gauge/hour meter.

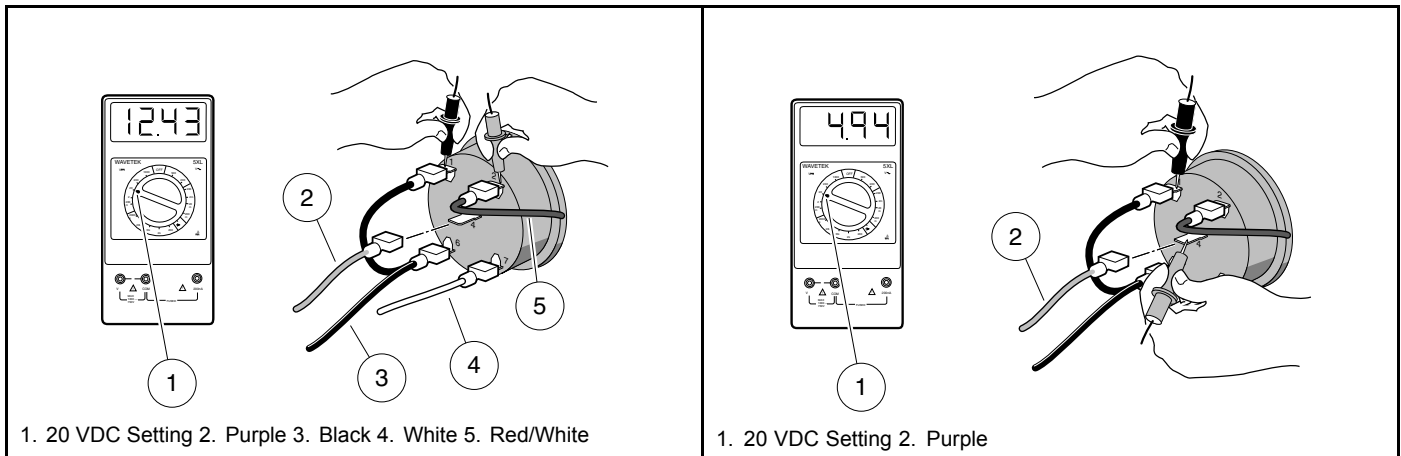

481 **Figure 18-21 Fuel Gauge Voltage Test - Terminal 2**

482 **Figure 18-22 Fuel Gauge Voltage Test - Terminal 4**

TEST PROCEDURE 24 – Hour Meter

See General Warnings on page 1-1.

NOTE: Keep the battery connected while performing this test procedure.

1. If necessary, see Testing Basics on page 18-15.
2. Place the Forward/Reverse handle in NEUTRAL. Chock the wheels.
3. With the key switch OFF, check the hour meter display. It is powered by an internal battery and should always be on, even with the engine off and the key removed.
4. Start the engine and let it idle. **See following DANGER.**

⚠ DANGER

- Do not operate vehicle in an enclosed area without proper ventilation. The engine produces carbon monoxide, which is an odorless, deadly poison.

5. With engine idling, the "hour glass" icon should flash. If not, check the low oil warning light and the oil pressure switch. **See following NOTE. See also Test Procedure 18 – Low Oil Warning Light (LED) on page 18-36.**

NOTE: The hour meter is designed to record actual engine running time and will not start adding increments until the engine is running and the oil pressure switch has opened.

6. If the hour meter still does not function after the low oil warning light, oil pressure switch, and all of the appropriate wires have been checked for continuity, replace the fuel gauge/hour meter.

TEST PROCEDURE 25 – Light Switch

See General Warnings on page 1-1.

NOTE: The headlight circuit is protected by the 20-amp fuse. Check the fuse before this procedure is performed. See Test Procedure 2 – Fuses on page 18-19.

This is a voltage test.

1. If necessary, see Testing Basics on page 18-15.
2. Remove instrument panel. **See Instrument Panel Removal on page 4-10.**
3. Use a multimeter set to 20 volts DC and place alligator clips on the multimeter probes. Connect the red (+) probe to the light switch terminal where the green/white wire is connected.
4. Connect the black (–) probe of the multimeter to ground.
5. With the light switch in the OFF position, the reading should indicate 0 volts. With the light in the ON position, the reading should indicate battery voltage. If there is no voltage reading, check associated wiring and 10-amp fuse (located in electrical component box). **See Test Procedure 2 – Fuses on page 18-19.** If the wires and fuse show continuity and the readings are still incorrect, replace the switch. **See Headlight Switch Removal, Section 20, Page 20-30.**

TEST PROCEDURE 26 – Voltage at Headlight Socket

See General Warnings on page 1-1.

NOTE: This is a voltage test.

1. If necessary, see Testing Basics on page 18-15.
2. Inspect the wires at the light bulb socket. Make sure the wires are securely fastened to the contacts inside the socket and that wires are oriented correctly - black to black and blue to blue.
3. Remove the wire harness connector from the headlight bulb (**Figure 18-23, Page 18-42**).
4. With the light switch in the ON position, probe across the two terminals in the connector. If battery voltage is shown, check/replace the headlight bulb.

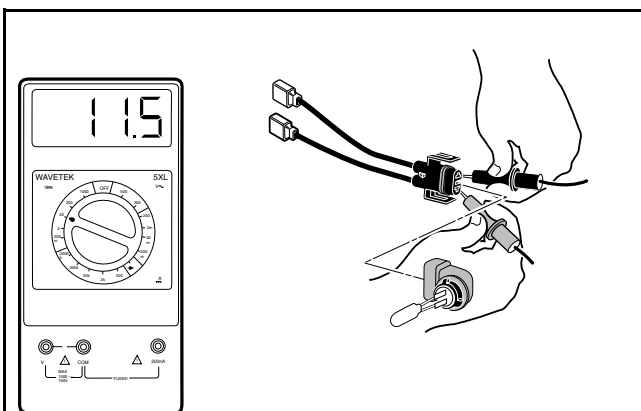

485

Figure 18-23 Voltage Measurement at Headlight Socket

5. If there is no voltage reading, check associated wiring, light switch and 10-amp fuse (located in electrical component box). **See Test Procedure 2 – Fuses on page 18-19.** **See Test Procedure 25 – Light Switch on page 18-42.**

TEST PROCEDURE 27 – Voltage Limiter

See General Warnings on page 1-1.

NOTE: This is a diode test.

The voltage limiter is a diode. Diodes are designed to conduct current in one direction only. **See following NOTE.**

NOTE: If the voltage limiter conducts current in both directions, the diode has failed closed. If the voltage limiter will not conduct current in either direction, the diode has failed open.

1. If necessary, see Testing Basics on page 18-15.
2. Turn the key switch OFF and remove the key. Place the Forward/Reverse handle in the NEUTRAL position. Chock the wheels.
3. Remove the cowl. **See Cowl Removal, Section 4, Page 4-5.**
4. Disconnect green wire from positive (+) terminal of voltage limiter and black wire from negative (-) terminal.
5. Using a multimeter on diode setting, test voltage limiter as shown (**Figure 18-24, Page 18-43**).

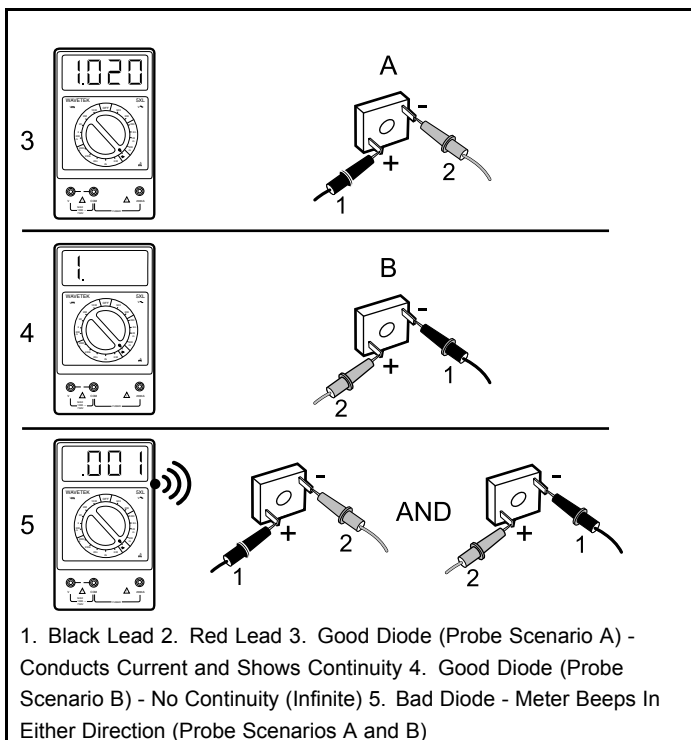

3032

Figure 18-24 Voltage Limiter Test

TEST PROCEDURE 28 – 4-Pin Connector (for Connected Car Device)

See General Warnings on page 1-1.

NOTE: This is a voltage and continuity test.

The Connected Car Device 4-pin connector is used for Guardian/Visage and is labeled “V3 circuit” on the main wire harness.

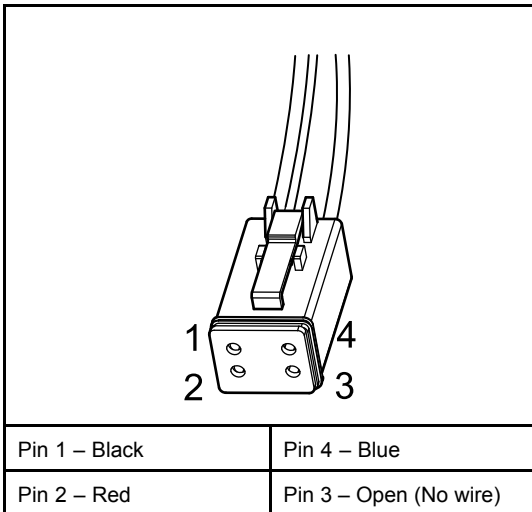

2786

Figure 18-25 4-Pin Connector

1. If necessary, see Testing Basics on page 18-15.
2. Check for continuity between pin 1 (black wire) (**Figure 18-25, Page 18-44**) and pin 18 (black wire) of the black 18-pin connector on the ECU. It should indicate continuity. If not, check sonic welds no. 4, 10, and 14.
3. Probe pin 2 (red wire). It should show battery voltage with the key switch in the ON position. If not, check 2-amp fuse near 4-pin connector. **See following NOTE.**

NOTE: The red wire only has battery voltage with the key switch in the ON position.

4. Probe pin 4 (blue wire). It should show approximately 11.8 volts supplied by pin 8 (blue/white wire) of the black 18-pin connector on the ECU. If not, check wiring and then ECU. **See following NOTE.**

NOTE: The blue wire only has voltage with the key switch in the ON position.

If pin 4 has no voltage, the ECU LIN (Local Interconnect bus) may have failed. The vehicle can be driven if it is not used with Guardian or Visage and will not show any symptoms. Otherwise, Guardian or Visage will disable the vehicle until communication is restored.

⚠ DANGER

- See General Warnings on page 1-1.

⚠ WARNING

- See General Warnings on page 1-1.

GENERAL INFORMATION

⚠ WARNING

- To prevent damage to the ECU, never mix the black and gray connectors that attach to it. The black connector is tethered to the ECU mounting plate to help prevent accidentally installing it in the gray port.

This section covers only the components that make troubleshooting the key-start gasoline vehicle different from the pedal-start gasoline vehicle. Use this information in addition to the **Troubleshooting and Electrical System: Pedal-Start Gas Vehicle** section. Most components are shared between the two systems except for the following items unique to the key-start vehicle:

- **Key Switch:** Only way to start and shut off the engine.
- **Accelerator Pedal:** Is not linked to the accelerator pedal limit switch and kill limit switch in the electrical component box because these switches are omitted for key-start applications.
- **Charging Diode:** Is connected to the solenoid in the electrical component box.
- **Forward/Reverse Shifter:** Is not linked to the neutral lockout limit switch on the transaxle because this switch is omitted for key-start applications.

In addition to troubleshooting, this section contains general information on the key-start electrical system and the circuits of the key-start electrical system.

WIRING DIAGRAMS

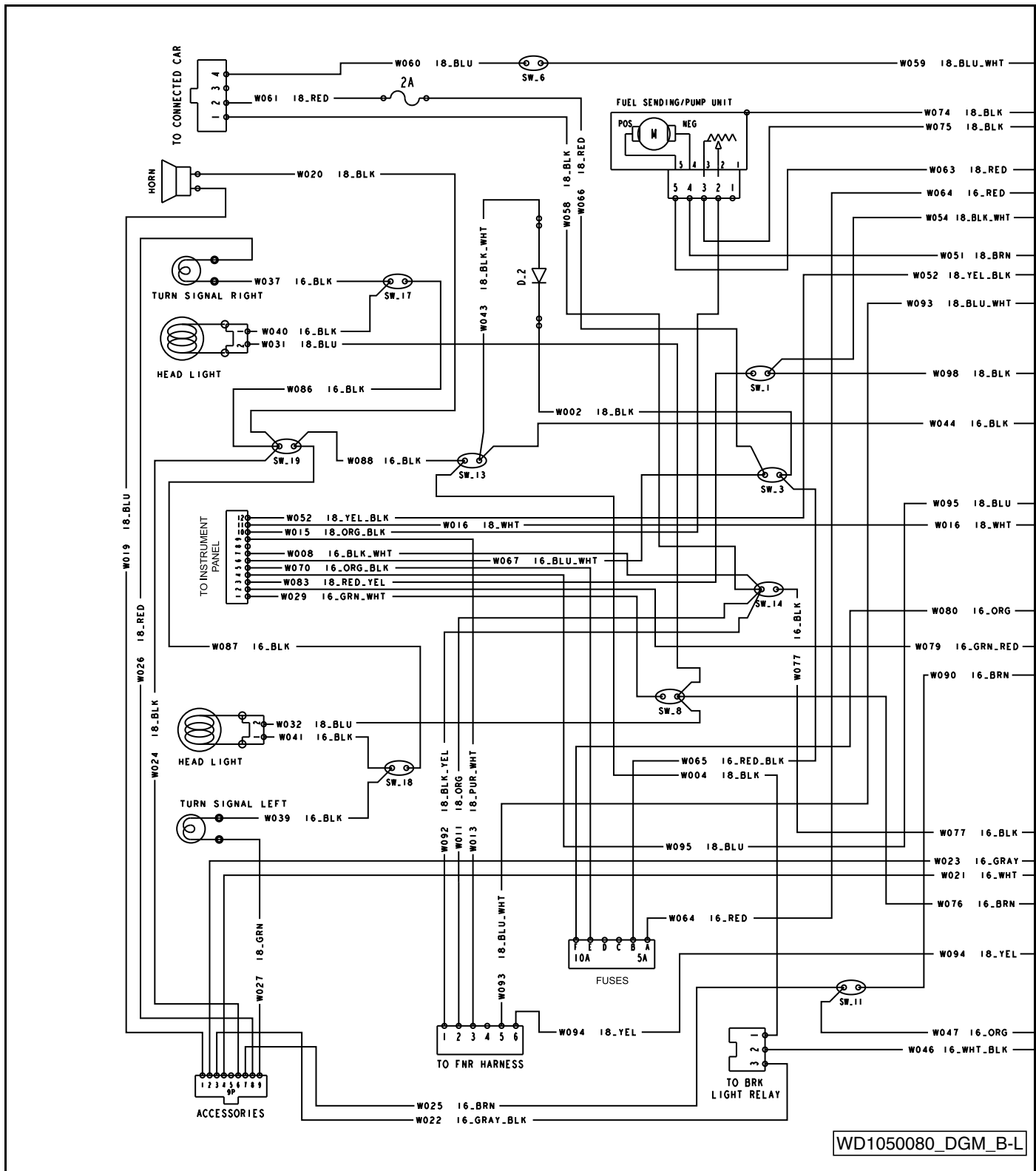

Figure 19-1 Wiring Diagram for Key-Start Gasoline Vehicle

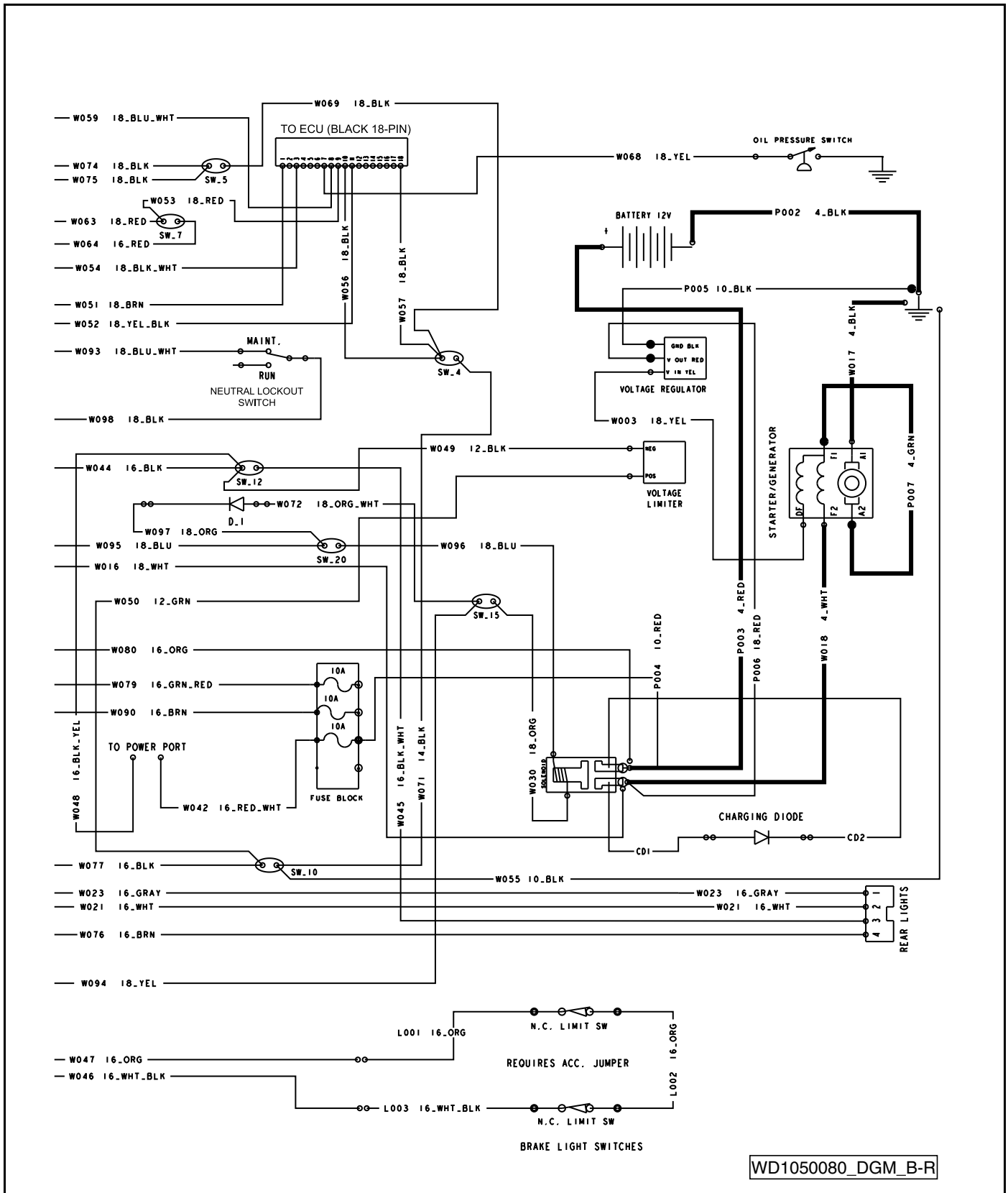
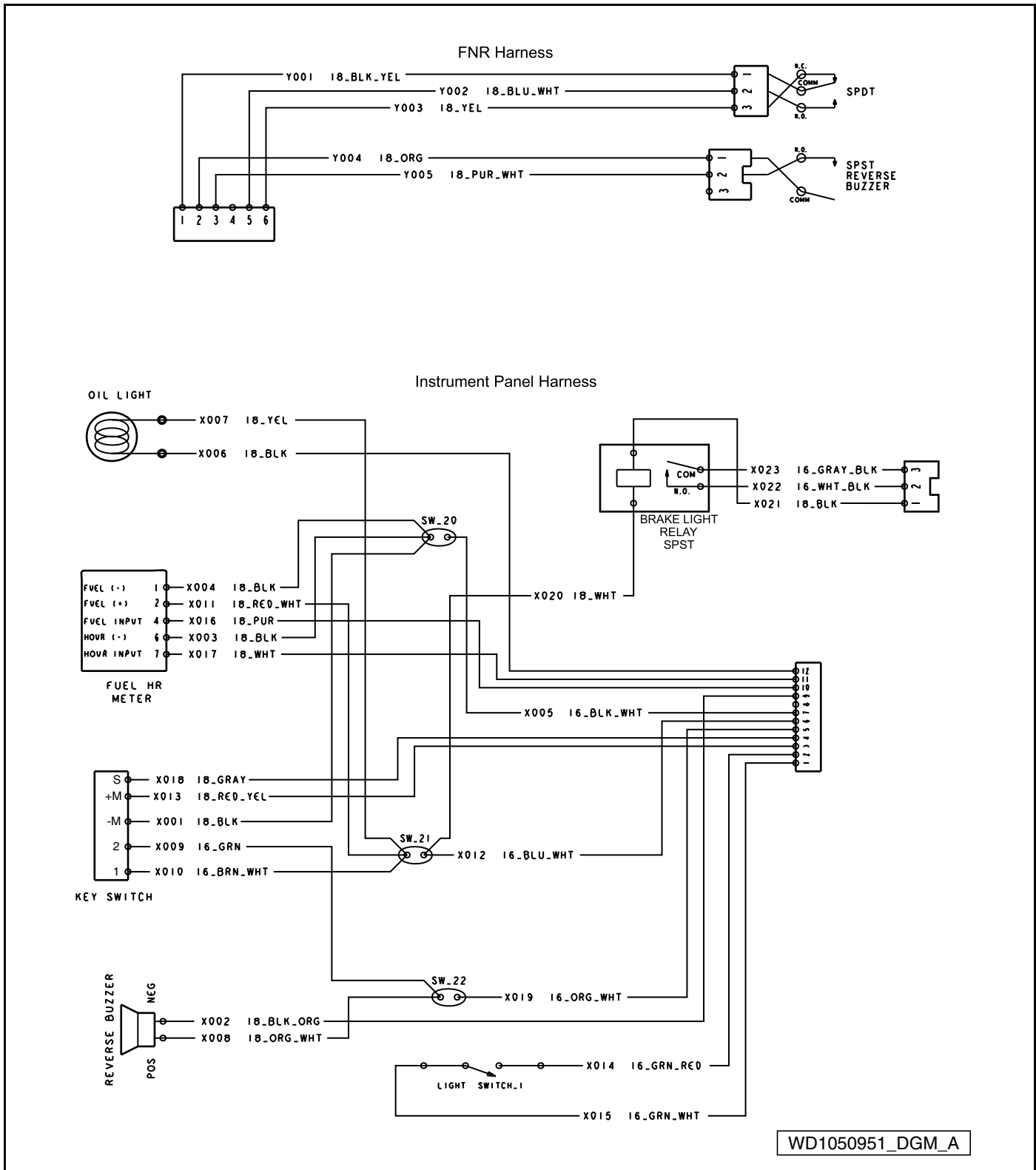
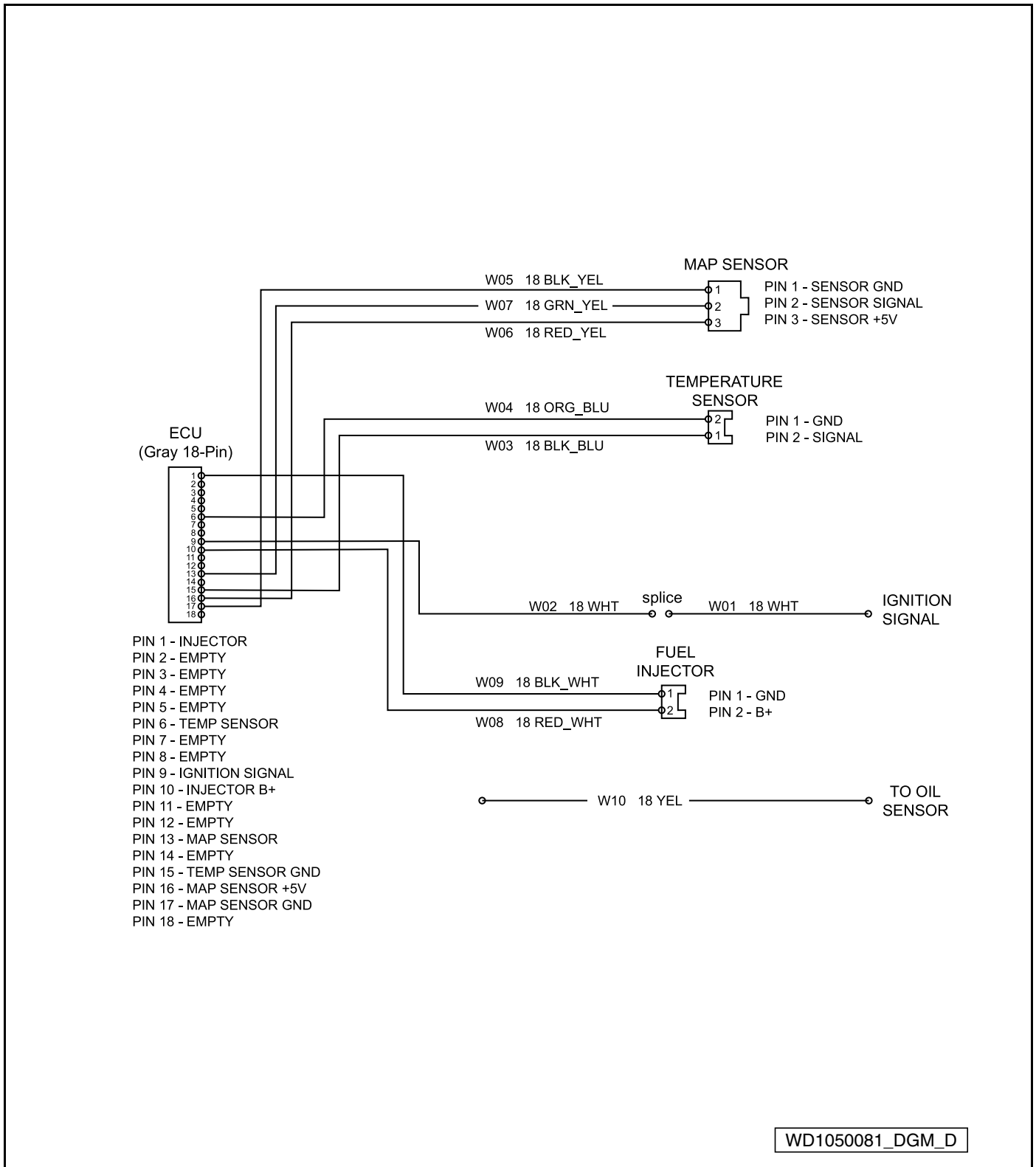

Figure 19-2 Wiring Diagram for Key-Start Gasoline Vehicle – Continued



WD1050951_DGM_A

Figure 19-3 Wiring Diagram – Instrument Panel and FNR Shifter



WD1050081_DGM_D

Figure 19-4 Wiring Diagram – EFI and Engine

TEST PROCEDURES

Using the following procedures, the entire electrical system can be tested without major disassembly of the vehicle.

⚠ WARNING

- If wires are removed or replaced, make sure wiring and wire harness is properly routed and secured. Failure to properly route and secure wiring could result in vehicle malfunction, property damage, personal injury, or death.

For some tests, the electrical component box cover must be removed to gain access to the various components that are mounted inside the component box. **See following WARNING.**

⚠ WARNING

- Shorting of battery terminals can cause personal injury or death.

After test procedures are completed, be sure to replace the cover. **See following CAUTION.**

CAUTION

- Exposure to water and the elements may damage electrical components. Do not operate vehicle without the cover properly installed.

Index of Test Procedures

- 1 – EFI System (ECU and Sensors)
- 2 – Key Switch (ON Position)
- 3 – Key Switch (START Position)
- 4 – Solenoid
- 5 – Maintenance/Operate Switch – Key-Start Vehicles
- 6 – Charging Diode (Generator Circuit) – Key-Start Vehicles Only

TEST PROCEDURE 1 – EFI System (ECU and Sensors)

See General Warnings on page 1-1.

⚠ WARNING

- This procedure involves testing voltage, resistance and continuity. If necessary, see Testing Basics on page 18-15.

In key-start vehicles, pin 12 of the ECU black 18-pin connector is not used. Pin 12 provides Foot Input to the ECU in pedal-start applications only. See Test Procedure 4 – EFI System (ECU and Sensors) on page 18-22 for all other ECU testing.

TEST PROCEDURE 2 – Key Switch (ON Position)

See General Warnings on page 1-1.

NOTE: *This is a voltage test.*

The key switch ON position provides power and KEY INPUT to the ECU.

1. If necessary, see Testing Basics on page 18-15.
2. Remove instrument panel to access the back of the key switch but do not disconnect wires. **See Instrument Panel Removal on page 4-10.**
3. With the key switch in the OFF position:
 - The green wire should show battery voltage coming to the switch.
 - The brown/white wire should show zero (0) volts. If it shows battery voltage, the switch has failed CLOSED and must be replaced.
4. With the key switch in the ON position:
 - The brown/white wire should show battery voltage passing through the key switch to sonic weld 3, the 5-amp fuse, the solenoid, and the 4-pin connected car plug. If it does not show battery voltage, the switch has failed OPEN and must be replaced.

TEST PROCEDURE 3 – Key Switch (START Position)

See General Warnings on page 1-1.

NOTE: *This is a voltage test.*

The key switch START position provides power to the starter/generator.

1. If necessary, see Testing Basics on page 18-15.
2. Remove instrument panel to access the back of the key switch but do not disconnect wires. **See Instrument Panel Removal on page 4-10.**
3. With the key switch in the OFF position:
 - The green wire should show battery voltage coming to the switch.
 - The gray wire should show zero (0) volts. If it shows battery voltage, the switch has failed CLOSED and must be replaced.
4. With the key switch in the START position:
 - The gray wire should show battery voltage passing through the key switch to sonic weld 20 and the solenoid coil. If it does not show battery voltage, the switch has failed OPEN and must be replaced.

TEST PROCEDURE 4 – Solenoid

See General Warnings on page 1-1.

NOTE: This is a resistance and voltage test.

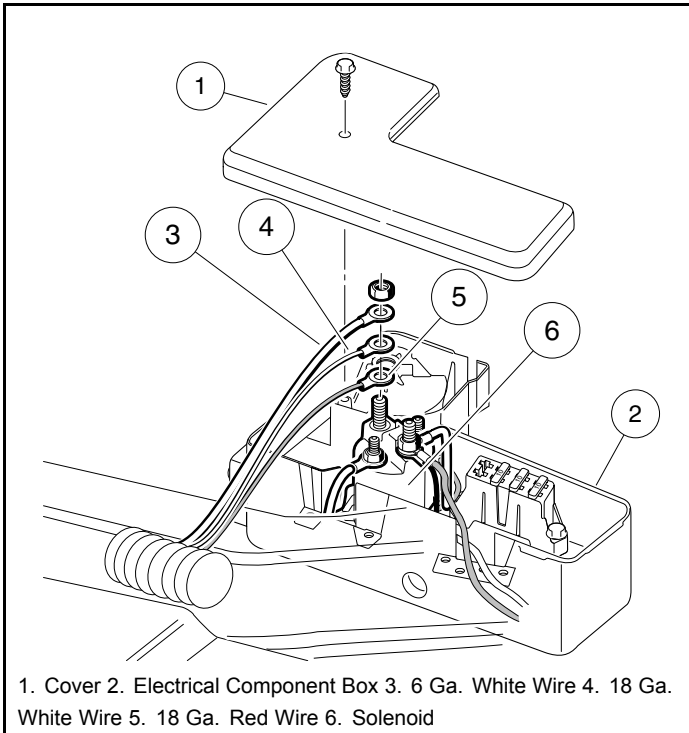

3025

Figure 19-5 Solenoid Wire Removal

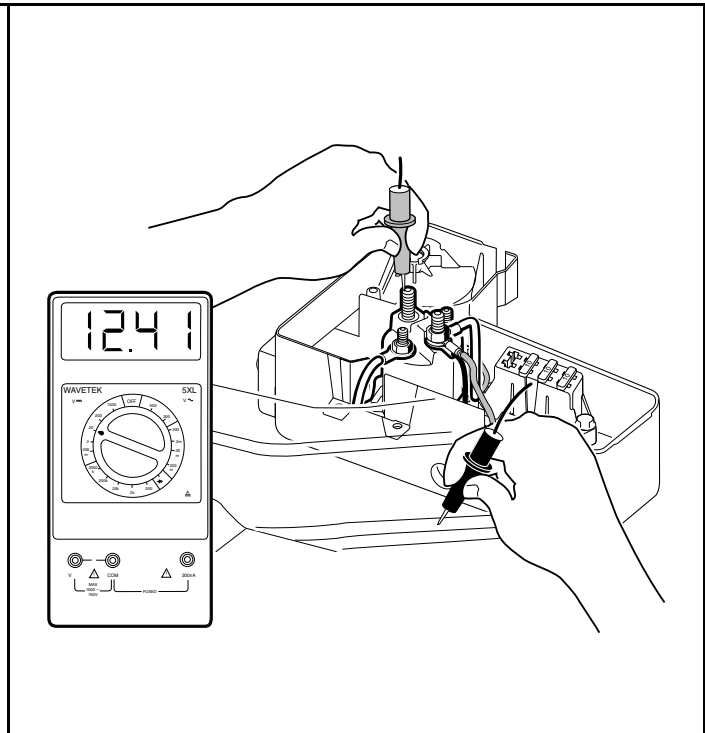

3027

Figure 19-6 Solenoid Voltage Test

1. If necessary, see Testing Basics on page 18-15.
2. Remove the electrical component box cover.
3. Ensure that the wires are connected correctly and are tight. If they are not, rewire or tighten as necessary.
4. **Coil Side:** Check resistance across the small posts of the solenoid. The reading should be 14 to 16 ohms. If the reading is not within limits, replace the solenoid.
5. **Contact Side:** Remove the 4-gauge white wire, the 10-gauge white wire, the 18-gauge red wire, and 18-gauge white wire from the large post of the solenoid. Do not allow the wires to touch the frame or other components of the vehicle (**Figure 19-5, Page 19-8**). Cover the other large post.
 - 5.1. Place Forward/Reverse handle in the NEUTRAL position and neutral lockout switch in the MAINTENANCE position.
 - 5.2. Check voltage between the empty large post and ground (**Figure 19-6, Page 19-8**).
 - **With key switch in the OFF and ON positions:** The meter should read no voltage.
 - **With key switch in the START position:** The solenoid should click and the meter should read battery voltage.
 - 5.3. If the readings are incorrect, replace solenoid. **See Solenoid Removal, Section 21, Page 21-3.**

TEST PROCEDURE 5 – Maintenance/Operate Switch – Key-Start Vehicles

See General Warnings on page 1-1.

NOTE: This is a continuity test.

The Maintenance/Operate Switch is also known as the Neutral Lockout Switch.

1. If necessary, see Testing Basics on page 18-15.
2. Remove wires from switch (**Figure 18-12, Page 18-28**).
3. With switch in position 1 (MAINTENANCE):
 - 3.1. Check for no continuity between terminals T1 and T2.
 - 3.2. Check for continuity between terminals T2 and T3.
4. With switch in position 2 (OPERATE):
 - 4.1. Check for no continuity between terminals T2 and T3.
 - 4.2. Check for continuity between terminals T1 and T2.

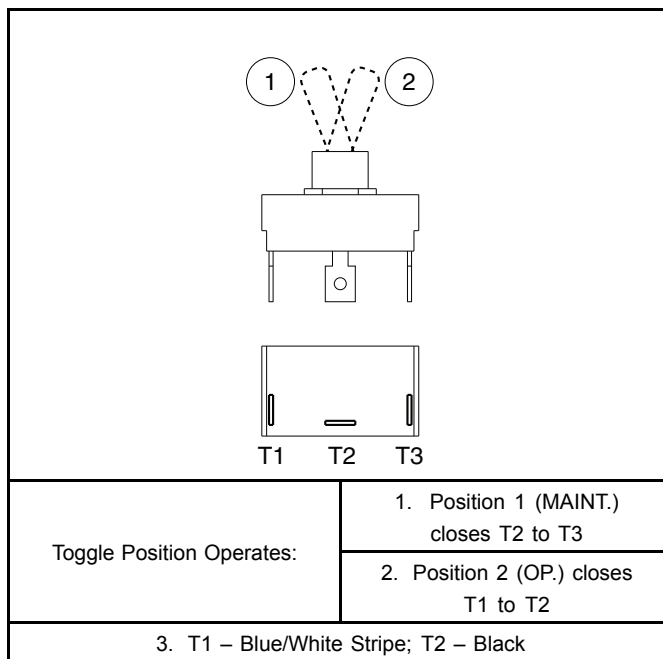

⁴⁷⁸

Figure 19-7 Maintenance/Operate Switch Test – for Key-Start Vehicles

5. If switch:
 - 5.1. does not work as stated in previous steps, replace switch.
 - 5.2. does work as stated and the MAINTENANCE/OPERATE modes still do not work:
 - Check the fuse.
 - Check the limit switches.
 - Check continuity of the wires involved.

TEST PROCEDURE 6 – Charging Diode (Generator Circuit) – Key-Start Vehicles Only

See General Warnings on page 1-1.

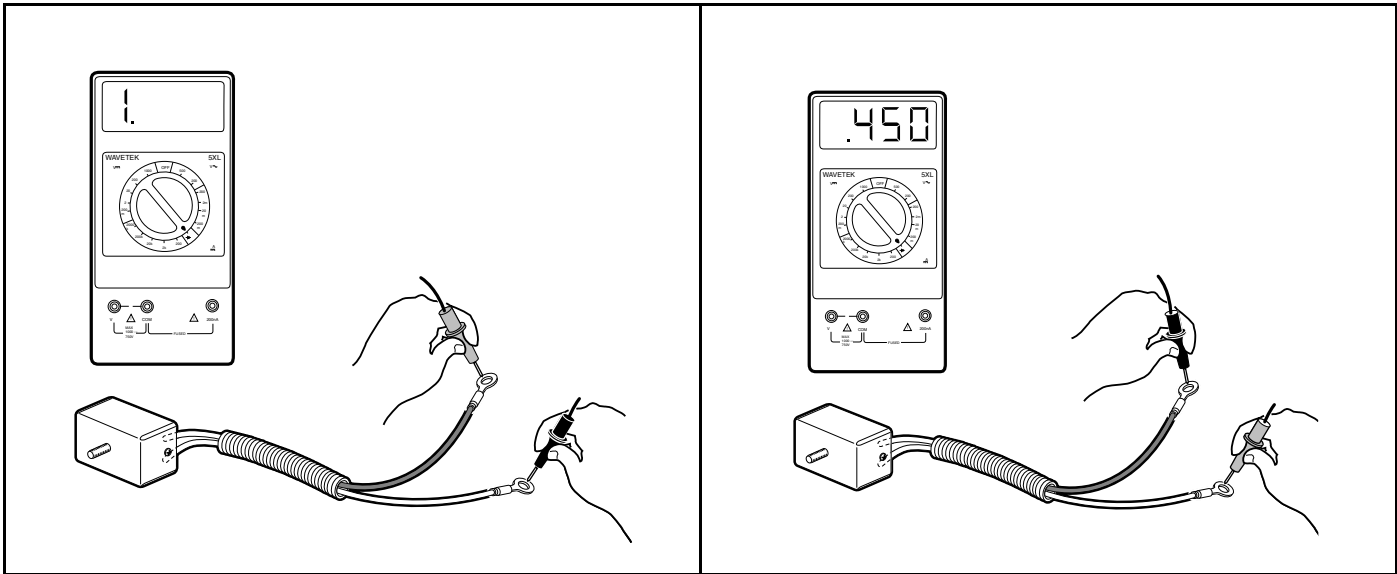

1700-30100-10383

Figure 19-8 Diode Test

1700-30100-10384

Figure 19-9 Diode Test – Probes Reversed

1. Turn the key switch OFF and remove the key. Place the Forward/Reverse handle in the NEUTRAL position. Chock the wheels.
2. Disconnect battery and spark plug wire(s). **See Disconnecting the Battery-Gasoline Vehicles on page 1-5.**
3. Disconnect the 10-gauge red wire and 10-gauge white wire of the diode assembly from the solenoid posts, located within the electrical component box.
 - 3.1. Remove the cover retaining screw (1) and electrical component box cover (2) (**Figure 21-2, Page 21-5**).
 - 3.2. Remove the locknuts (3) from the two large solenoid posts and disconnect the diode wires from the solenoid.
4. With the multimeter set to the diode test function, connect the black (–) probe of the multimeter to the white lead of the diode and the red (+) probe of the multimeter to the red lead of the diode (**Figure 19-8, Page 19-10**). The reading should indicate an overload (no continuity). A diode is designed to conduct current in one direction only. If a diode conducts current (shows continuity) with the meter probes as described, the diode has failed and must be replaced. **See Charging Diode Removal, Section 21, Page 21-4.**
5. Reverse the multimeter probes and note the reading. With the black (–) probe of the multimeter to the red lead of the diode and the red (+) probe of the multimeter to the white lead, the meter should read approximately 450 mV, however, a range from 400 to 500 mV is acceptable (**Figure 19-9, Page 19-10**).
6. Connect either the black (–) or red (+) lead of the multimeter to the diode body (case). Connect the other multimeter lead to both the red and white lead terminals of the diode. The multimeter should indicate an overload, (no continuity). If continuity reading does occur, it indicates that one or both of the diode leads are grounded to the diode body (case) and the diode must be replaced. **See Charging Diode Removal, Section 21, Page 21-4.**
7. If the diode tests good, reconnect the diode leads. **See Charging Diode Installation, Section 21, Page 21-5. See also following WARNING.**

⚠ WARNING

- Incorrect wiring could result in severe injury or death.

WARNING CONTINUED ON NEXT PAGE

⚠ WARNING

- Diode and solenoid connections must have correct polarity.
- Keep all persons clear of engine belts when making final connections.

Pagination Page

⚠ DANGER

- See General Warnings on page 1-1.

⚠ WARNING

- See General Warnings on page 1-1.

STARTER/GENERATOR

See General Warnings on page 1-1.

TESTING THE STARTER/GENERATOR

See Test Procedure 12 – Starter/Generator (Starter Function) on page 18-30.

See Test Procedure 11 – Starter/Generator (Generator Function) on page 18-30.

STARTER/GENERATOR REMOVAL

1. Disconnect battery and spark plug wire(s). See **Disconnecting the Battery-Gasoline Vehicles** on page 1-5.
2. Place the neutral lockout switch in the MAINTENANCE position. Access the engine compartment by removing the seat or raising the cargo bed.
3. Disconnect the wires from the starter/generator (1) (**Figure 20-14, Page 20-13**).
4. Loosen the pivot nuts (7) and bolts (5) (**Figure 20-13, Page 20-12**).
5. Remove the adjustment nut (4), washer (6) and adjustment bolt (1) (**Figure 20-13, Page 20-12**). Lower the starter/generator and remove the belt (2) from the pulley.
6. Support the starter/generator so that when the pivot bolts (5) are removed the starter/generator will not fall. Remove the two pivot nuts (7) and bolts (5) from the mounting bracket.
7. Remove the starter/generator.

DISASSEMBLY OF THE STARTER/GENERATOR TO SERVICE THE BRUSHES

1. Remove the two bolts (20) and pull commutator end cover (23) free of starter/generator housing (24) (**Figure 20-1, Page 20-2**). See following NOTE.

NOTE: *If the brushes are not removed, contact between the brushes and commutator as the commutator end cover is being removed or installed could damage the brushes. Lift the brush springs out of the notches in the brushes and pull the brushes back from the center of the commutator end cover. The springs will rest on the sides of the brushes and help prevent them from sliding towards the center of the cover (**Figure 20-5, Page 20-4**).*

2. Remove brush covers (29 and 30), terminal hardware (25), brush springs (28), and brushes (27) (**Figure 20-2, Page 20-2**). See following NOTE.

NOTE: *To clean and inspect the armature/commutator and the bearings, see **Disassembly of the Starter/Generator to Service the Armature/Commutator** on page 20-4.*

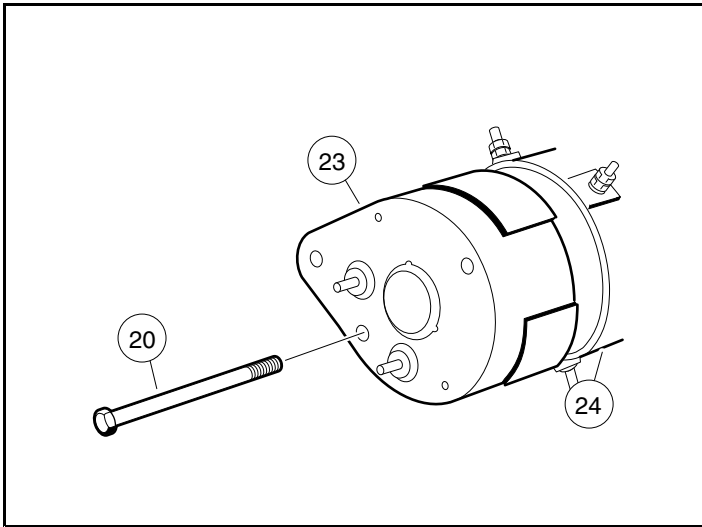

487

Figure 20-1 Commutator End Cover

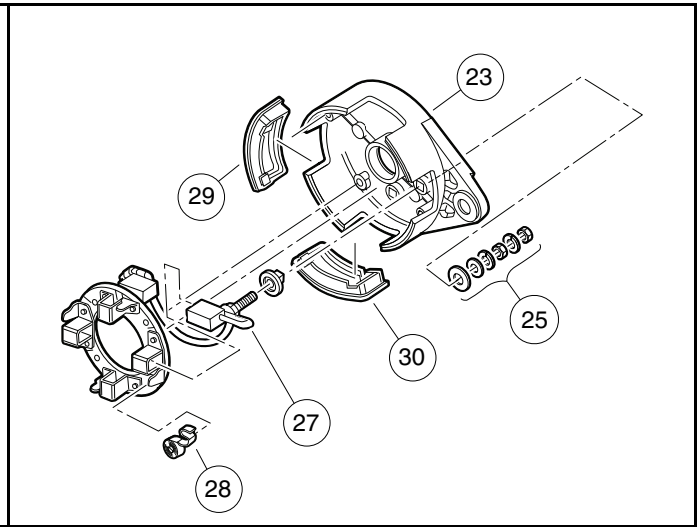

Figure 20-2 Brush Covers and Brushes

BRUSH INSPECTION AND REPLACEMENT

1. Visually inspect brushes. Replace brushes that are cracked or severely chipped.
2. Measure the length of each brush. Replace the brush set if a brush is less than 0.375 inch (9.5 mm) (**Figure 20-3, Page 20-2**).

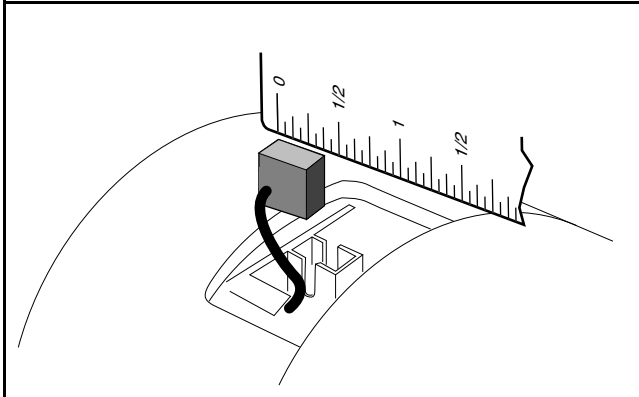

Figure 20-3 Inspect Brushes and Measure Length

BRUSH SPRING INSPECTION AND REPLACEMENT

1. Visually inspect springs. Replace all four springs if any spring is discolored from heat (straw or bluish in color).
2. Install the four brushes (27) into their holders and insert the four brush springs (28) (**Figure 20-2, Page 20-2**). Using a spring scale, test brush spring tension. If any spring has a tension less than 24 ozf (0.68 kgf), replace all four springs (**Figure 20-4, Page 20-3**). See following **CAUTION**.

⚠ CAUTION

- When checking brush spring tension, do not push springs beyond the point they would normally be if there were new brushes installed. Exerting excessive force or pushing brush springs beyond their normal maximum extension point will damage springs.

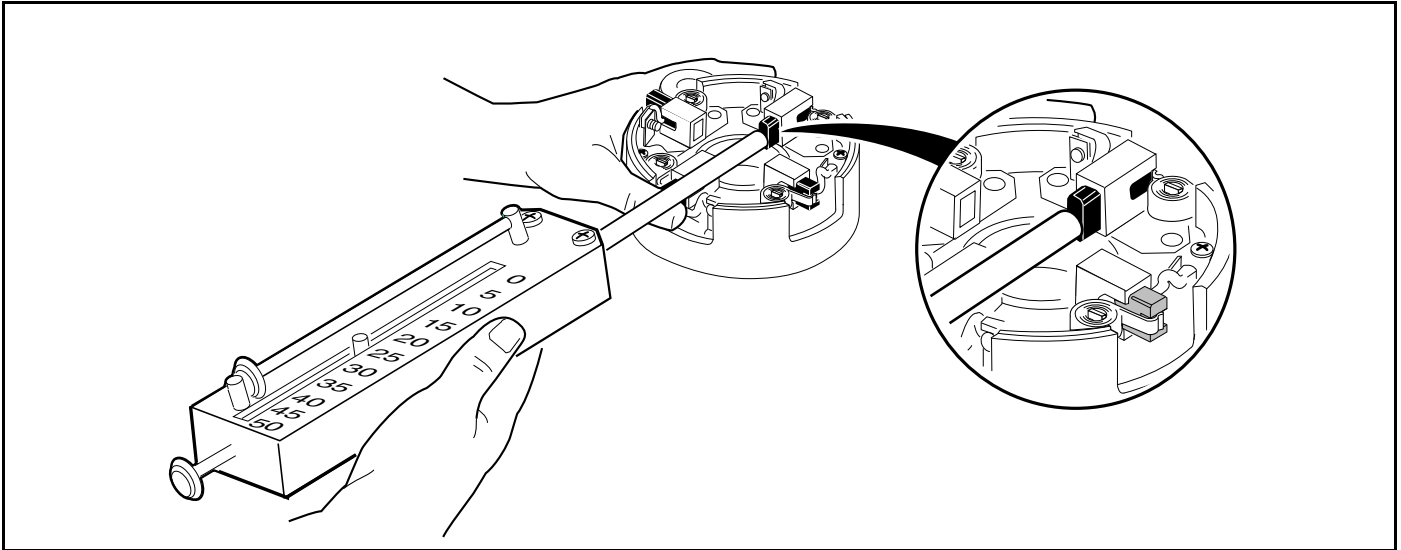

490

Figure 20-4 Brush Spring Tension Test

STARTER/GENERATOR ASSEMBLY

1. Install the brushes (27) into the holders. Install the terminal hardware (25) (**Figure 20-2, Page 20-2**).
2. To prevent contact between the brushes and commutator as the commutator is installed, and possible damage to the brushes, lift the brush springs and pull the brushes back from the center of the commutator end cover. The springs will rest on the sides of the brushes and help prevent them from sliding towards the center of the cover (**Figure 20-5, Page 20-4**).
3. Install the commutator end cover (23) onto the armature shaft. Align the locating pin with the pin hole in the cover. Install two M6 x 180 mm bolts (20) and tighten to 100 in·lb (11.3 N·m) (**Figure 20-1, Page 20-2**).
4. Push the brushes down into the holders. Position springs on the end of the brushes. Install the brush cover (30) that has the drain hole in it next to the A2 terminal. Install the remaining three brush covers (29) in the openings in the commutator end cover (23) (**Figure 20-2, Page 20-2**).

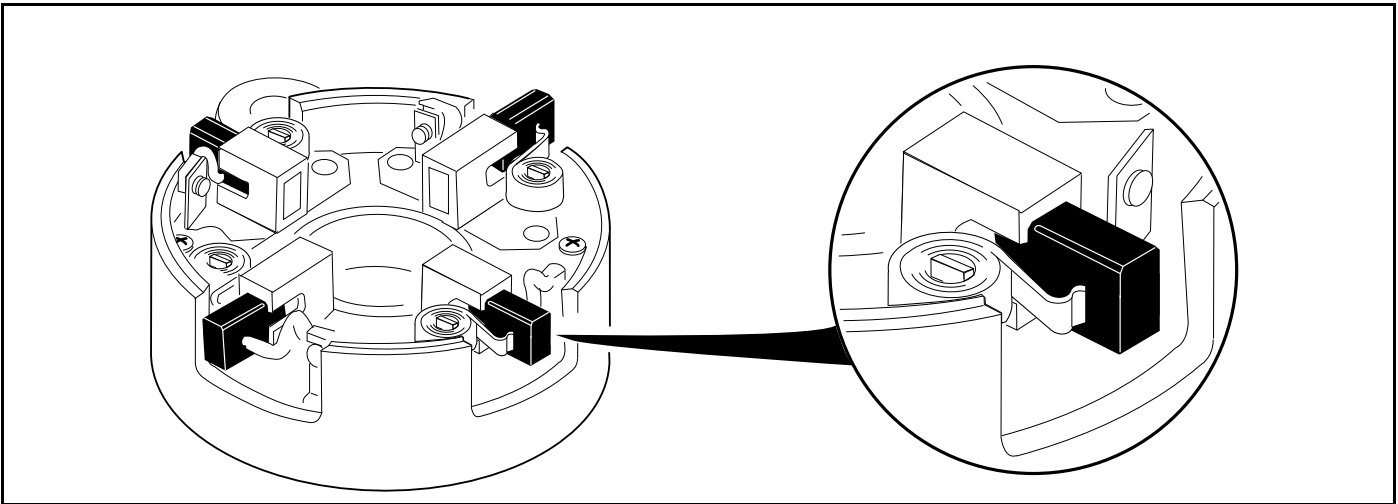
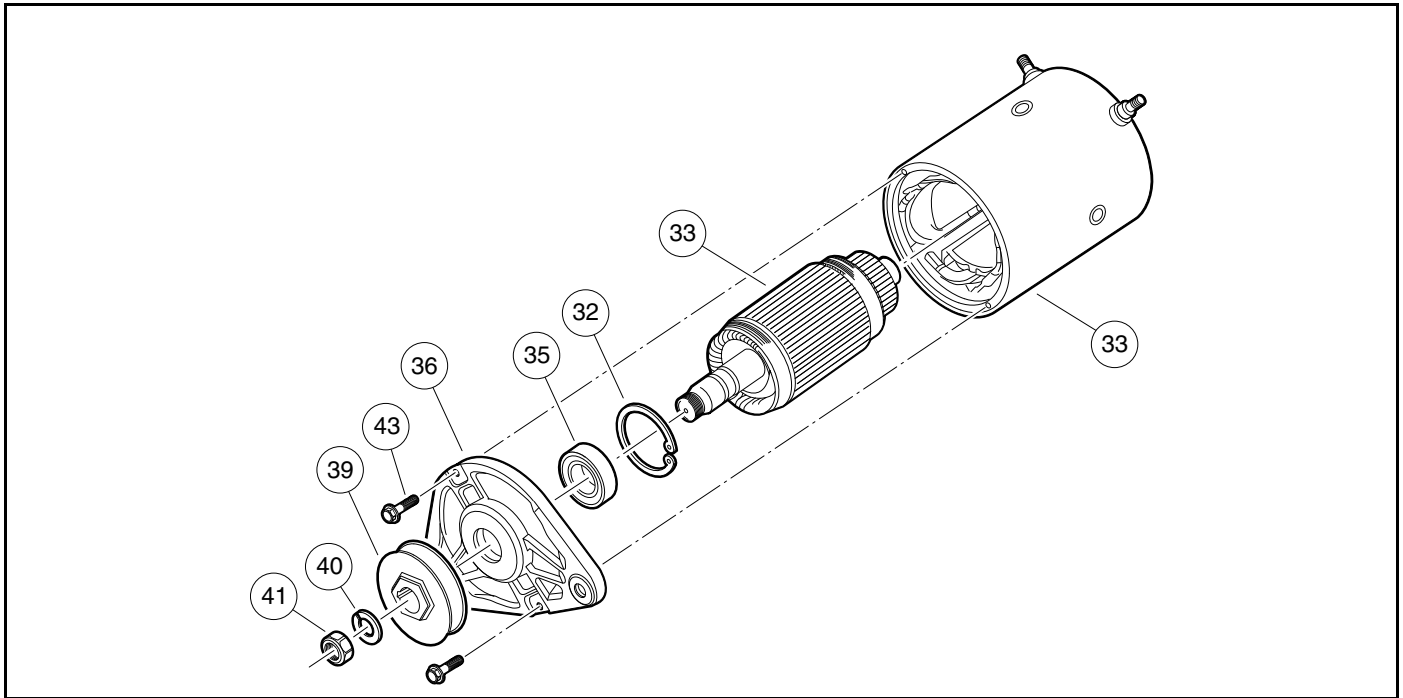

Figure 20-5 Pull Brushes Away From Center of the Commutator End Cover

DISASSEMBLY OF THE STARTER/GENERATOR TO SERVICE THE ARMATURE/COMMUTATOR

1. Remove the commutator end cover to prevent damage to the brushes and armature. **See Disassembly of the Starter/Generator to Service the Brushes on page 20-1.**
2. To separate armature and output end cover assembly from the field coil housing, first remove the two securing bolts (43). Carefully remove armature and output end cover assembly from the field coil housing so components are not damaged.
3. To separate armature (33) from output end cover (36), remove nut (41), lock washer (40), pulley (39). It may be necessary to use the wedge attachment tool (P/N 1012812) to remove the pulley from the shaft.
4. Remove the internal retaining ring (32) to release the bearing (35) and armature (33) from the output end cover (36). **(Figure 20-6, Page 20-5).**



1342

Figure 20-6 Output End Cover Assembly, Armature and Housing

BEARING CLEANING AND INSPECTION

1. Using a clean cloth, wipe the carbon dust from the two bearings. Inspect bearings by spinning them by hand and checking for both axial (A) and radial (B) play (**Figure 20-7, Page 20-5**).
2. Replace the bearing if it is noisy, does not spin smoothly, or has excessive play. Check the bearings and replace if rusted, worn, cracked, or if there is an abnormal color change in the metal of the bearing. Bearings should be replaced if there is extensive wear or pitting on the balls or on the rolling surfaces. Do not remove the bearings unless they are to be replaced.

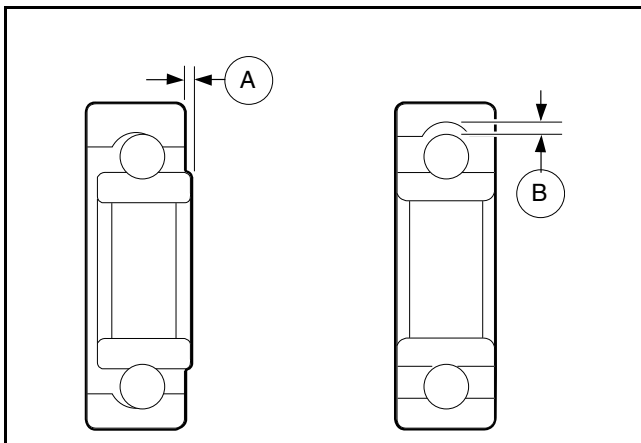

493

Figure 20-7 Bearing Play Inspection

BEARING REMOVAL

1. Place the wedge attachment tool (P/N 1012812) between the bearing and the armature. Make sure the wedge attachment tool is supporting the inner race of the bearing. If a press is not available, secure a bearing puller (P/N 1012811) to the wedge attachment tool and pull the bearing off of the end of the armature shaft. Support the armature so that it will not drop when the bearing is removed (**Figure 20-8, Page 20-6**).
2. Slide the bearing retainer ring (32) off of the output end of the shaft (**Figure 20-6, Page 20-5**).

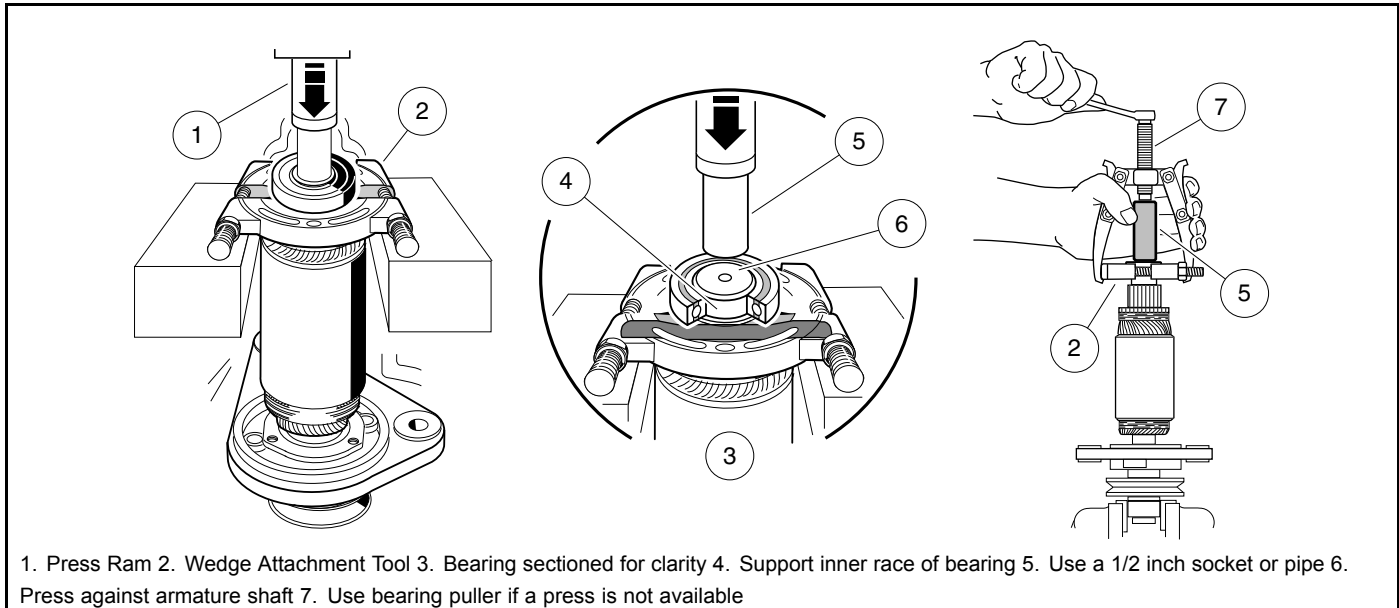

494

Figure 20-8 Bearing Removal**FIELD COIL ASSEMBLY**

Replace entire field coil housing assembly if coils, pole shoes or terminals are damaged. (**Figure 20-9, Page 20-7**).

VISUAL INSPECTION OF ARMATURE

Obvious defects can be seen by examining the armature. If an armature has frayed or charred insulation, broken wires or thrown solder, it is obvious without testing that it should be replaced. Faults seen during the visual inspection can aid in diagnosing the original cause of the failure. Items to look for are listed below.

- Burned, charred, or cracked insulation
- Improperly cured varnish
- Thrown solder
- Flared armature windings
- Worn, burned, or glazed commutator
- Loose or raised commutator bars
- Bruised or damaged armature core laminations
- Worn armature bearing or shaft
- Dirty or oily commutator

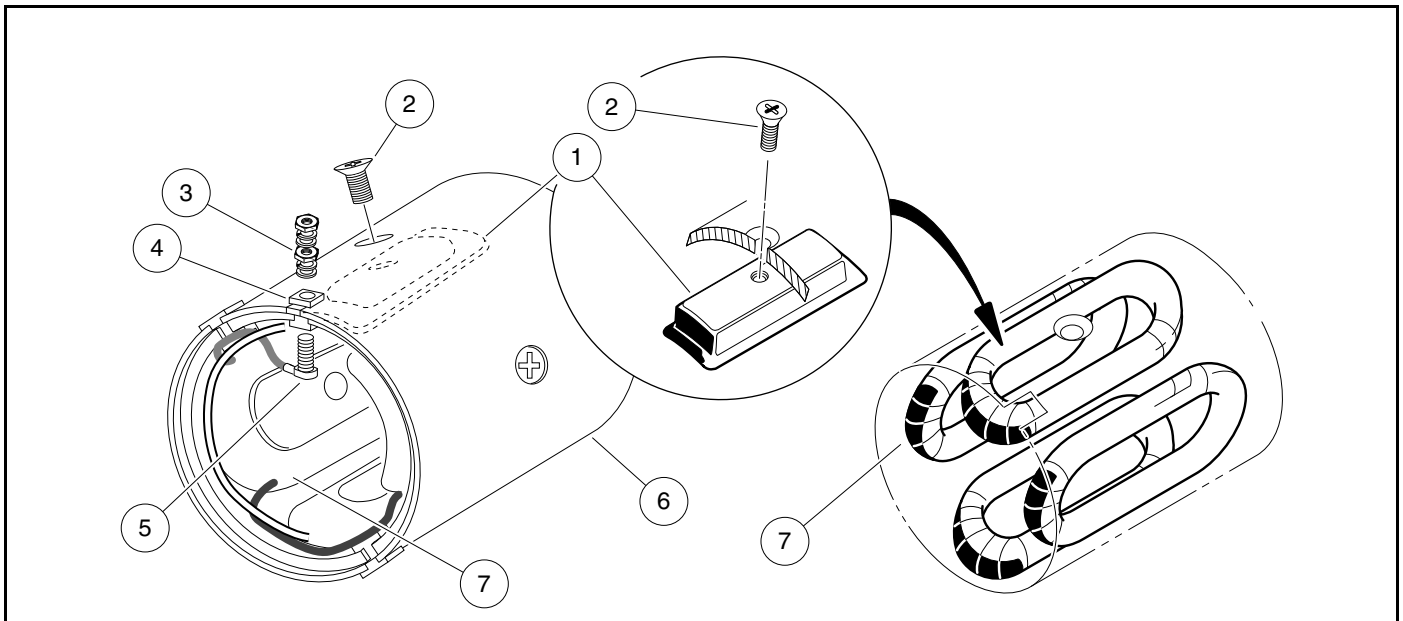

495

Figure 20-9 Field Coil Assembly

COMMUTATOR CLEANING AND INSPECTION

1. Clean the carbon dust, dirt and oil from the commutator. Visually inspect the commutator for worn, burned or glazed areas. Check for loose or raised commutator bars. Slight roughness of the commutator can be polished away with 400 grit (or finer) sandpaper. **See following CAUTION.**

⚠ CAUTION

- Do not use emery cloth on the commutator. Particles of emery are conductive and may short-circuit the commutator bars. Do not use oil or lubricants on the commutator or brushes.
2. Using a micrometer, measure the outside diameter at two points along the commutator. If the commutator outside diameter is less than 1.535 inches (39 mm), replace the armature and bearings (**Figure 20-10, Page 20-8**).

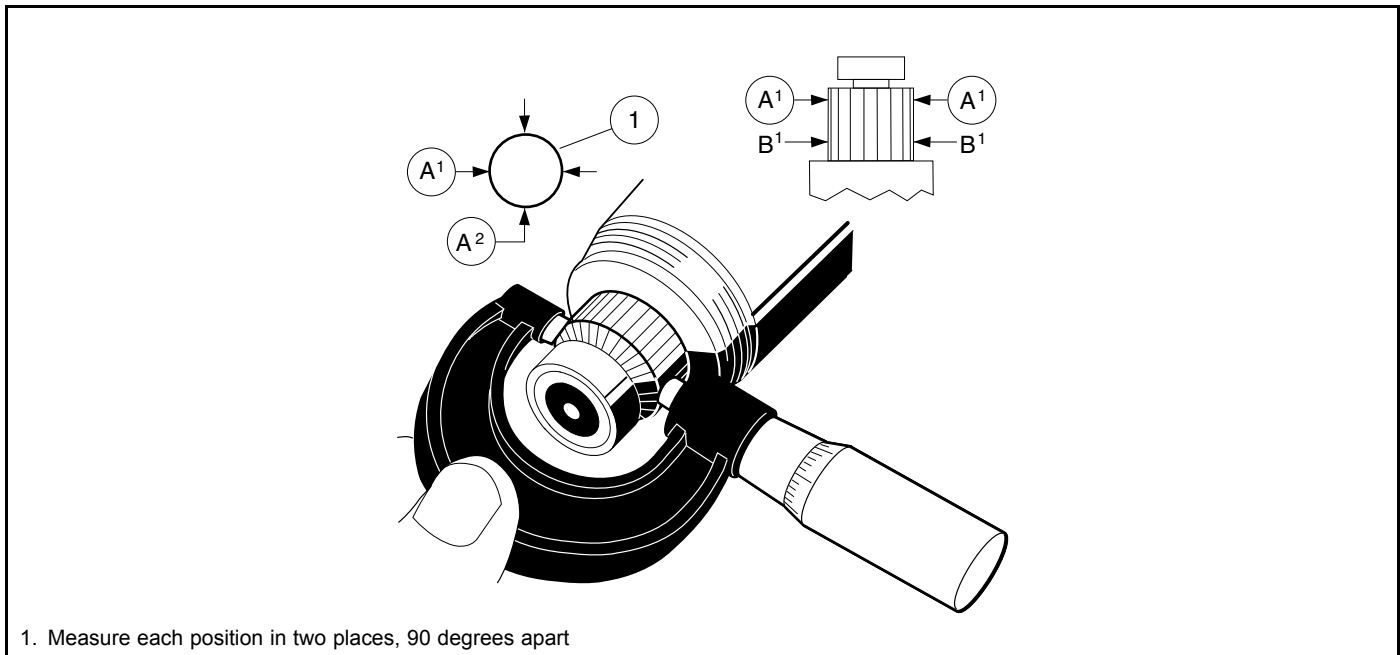

496

Figure 20-10 Inspect Commutator

ARMATURE GROUND TEST

⚠ CAUTION

- Do not submerge armature in solvent.

NOTE: Before testing, wipe the armature with a clean cloth and remove carbon dust and metal particles from between commutator bars.

Using a multimeter set on 200 ohms, place the positive (+) probe on the commutator bars and the negative (–) probe on the armature core. The reading should be no continuity. If the reading is incorrect, replace the armature and the two bearings (Figure 20-11, Page 20-9).

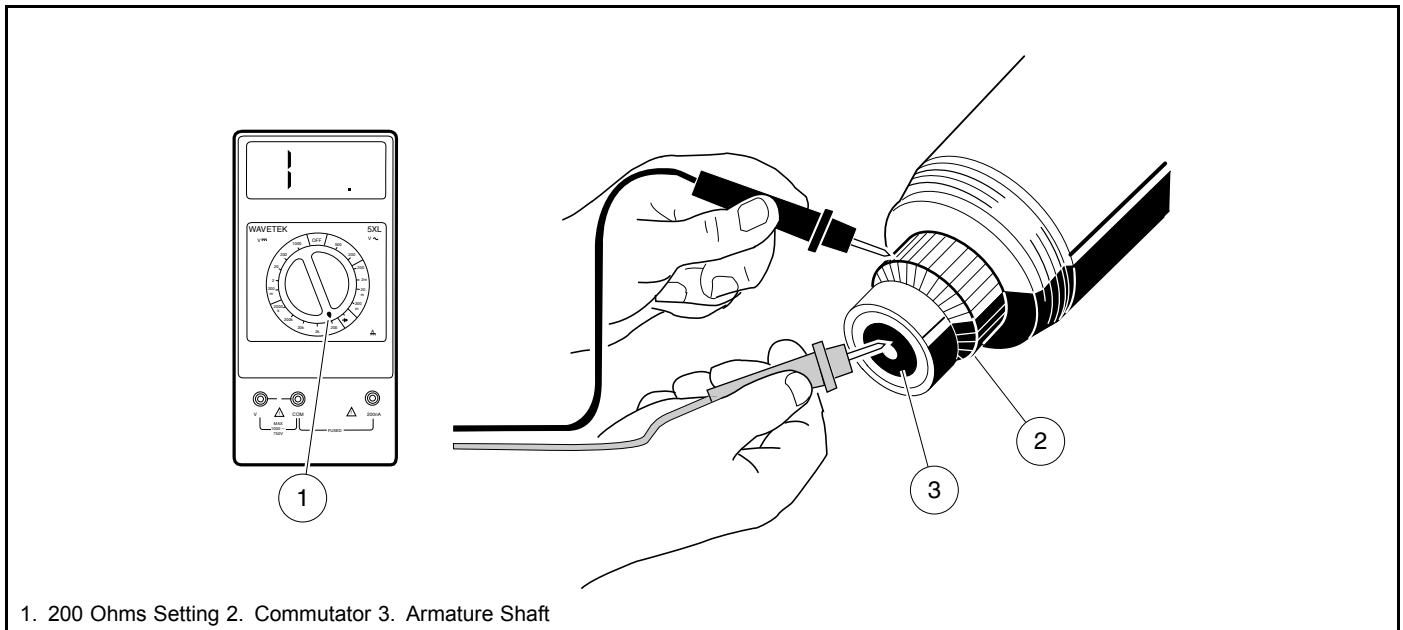

497

Figure 20-11 Armature Ground Test

VISUAL INSPECTION OF FIELD COILS

If the insulation on the field coils appears blackened or charred, the serviceability of the coils is questionable. Burned or scorched coil insulation indicates the starter/generator has overheated due to overloads or grounded or shorted coil windings. Be sure the insulators are tight in the housing.

STARTER/GENERATOR REWORK

Any rework must be performed by a qualified technician. Starter/generator service specifications are listed in the following table.

ITEM	SERVICE LIMIT
Commutator diameter (minimum)	1.60 in. (41 mm)
Concentric with armature shaft within	0.002 in. (0.051 mm)
Minimum commutator diameter for reslotting	1.65 in. (42 mm)
Undercut (Commutator must have a minimum diameter of 1.65 in (42 mm) for reslotting):	0.050 in. (1.3 mm)
Dielectric strength	500 VAC for one minute
Armature insulation resistance	0.2M (ohms) at 500 VDC
Starter field coil resistance	0.006 to 0.01 ohms
Generator field coil resistance	4.5 to 5.5 ohms

STARTER/GENERATOR ASSEMBLY

1. Slide the bearing retainer (32) onto the output end of the armature shaft (33) (**Figure 20-6, Page 20-5**).

2. Press a new ball bearing (35) onto the output end of the armature (**Figure 20-6, Page 20-5**). Press a new ball bearing onto the commutator end of the armature shaft. **See following CAUTION.**

⚠ CAUTION

- **To prevent damage to the retainer, use care while pressing new bearing onto the output end of the shaft.**
 - **Press against the inner race of the new bearing until it is fully seated.**
3. Install the drive end cover (36) onto the armature. Secure the bearing retainer ring (32) (**Figure 20-6, Page 20-5**).
 4. Slide the housing with field coils over the armature. Use the tapped mounting holes to align housing to the cover, rotate and orient as shown.

NOTE: *The terminal insulators should be on the commutator end of the housing.*

5. To prevent contact between the brushes and commutator as the commutator cover is installed, and possible damage to the brushes, lift the brush springs out of the notches in the brushes and pull the brushes back from the center of the commutator end cover. The springs will rest on the sides of the brushes and help prevent them from sliding towards the center of the cover (**Figure 20-5, Page 20-4**).
6. Install the commutator end cover (23) onto the armature shaft. Use the tapped mounting holes to align housing to the cover, rotate and orient as shown. Install the two M6 x 180 mm bolts (20), and tighten to 60 in·lb (6.8 N·m) (**Figure 20-1, Page 20-2**).
7. Push the brushes down into the holders. Place springs into the notches in the brushes. Install the brush cover (30) that has the drain hole in it next to the A2 terminal. Install the remaining three brush covers (29) in the openings in the commutator end cover (23) (**Figure 20-2, Page 20-2**).
8. Install the belt pulley (39) onto the shaft, and install the lock washer (40) and M14 nut (41). Tighten the nut to 30 ft·lb (40.7 N·m) (**Figure 20-6, Page 20-5**).
9. Install the A1 to F1 terminal jumper wire on the starter/generator.
 - 9.1. Loosely attach wire, flat washers, lock washers and nuts onto each terminal.
 - 9.2. Orient wire at A1 to be 1 inch (25.4 mm) away from A2 terminal as shown and tighten nut to 44 in·lb (5 N·m) (**Figure 20-12, Page 20-11**). **See following NOTE.**

NOTE: *Secure bottom nut of terminal with wrench before tightening top nut.*

- 9.3. Form wire against starter housing as shown and allow terminal at F1 to self-orient. Tighten nut to 44 in·lb (5 N·m). **See preceding NOTE.**

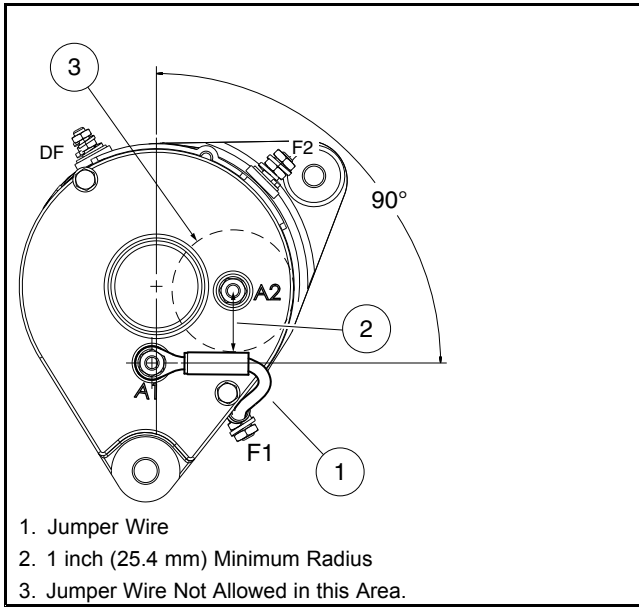

2687

Figure 20-12 A1 to F1 Terminal Jumper Wire Routing

STARTER/GENERATOR INSTALLATION

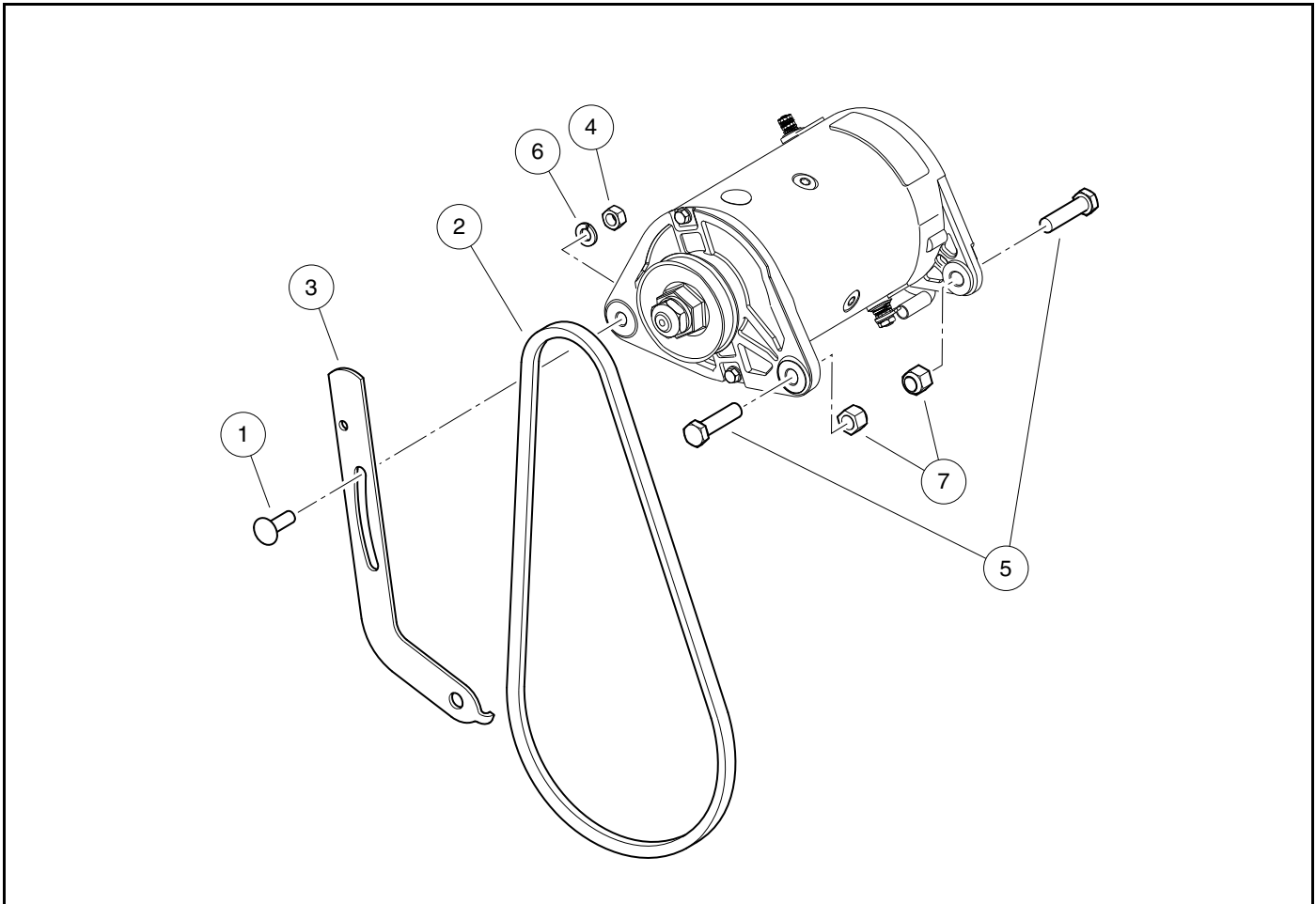

2997

Figure 20-13 Starter/Generator Installation

1. Install the green wire (1) from the F1 terminal to the A2 terminal on the starter/generator (**Figure 20-14, Page 20-13**). Install a flat washer, lock washer, and nut onto each terminal and tighten to 48 in·lb (5.4 N·m).
2. Position the starter/generator over the mounting bracket so that the bolts will go through the starter/generator before going through the bracket. Install pivot bolts (5) with the heads of the bolts facing as shown (**Figure 20-13, Page 20-12**). Install lock nuts (7) finger-tight.
3. Install the adjustment bolt (1) through the adjusting bracket (3) and then through the starter/generator. Install a lock washer (6) and nut (4) onto adjustment bolt (1) finger-tight (**Figure 20-13, Page 20-12**).
4. Install starter/generator belt (2) and adjust belt tension as instructed. **See Belt Tension Adjustment for EFI Engines on page 20-13.**
5. Connect the yellow wire (2) from the voltage regulator to the DF terminal on the starter/generator (**Figure 20-14, Page 20-13**). Install a flat washer, lock washer, and nut onto the terminal. Tighten the nut to 31 in·lb (3.5 N·m).
6. Install the white wire (3) from the solenoid to the F2 terminal on the starter/generator (**Figure 20-14, Page 20-13**). Install the black wire (4) from the frame to the A1 terminal on the starter/generator. Install a flat washer, lock washer and nut onto each terminal, and tighten the nut to 48 in·lb (5.4 N·m).
7. Connect battery and spark plug wire(s). **See Connecting the Battery-Gasoline Vehicles on page 1-5.**

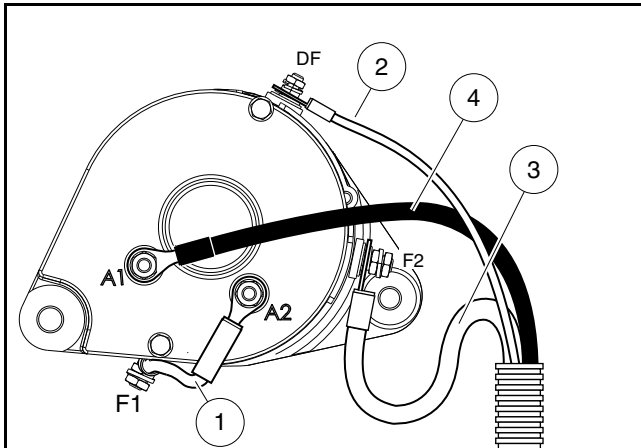

3033

Figure 20-14 Starter/Generator Wiring

BELT TENSION ADJUSTMENT FOR EFI ENGINES

NOTE: To prevent belt slipping while starting an EFI engine, follow procedure outlined below which is best performed by two people to expedite the process, but can be performed by a single individual if required.

The amount a starter/generator belt is tensioned varies between a used and new belt.

EFI engines have higher starting torque demands that require consistent belt tension to prevent slipping. Belt tension should be checked periodically.

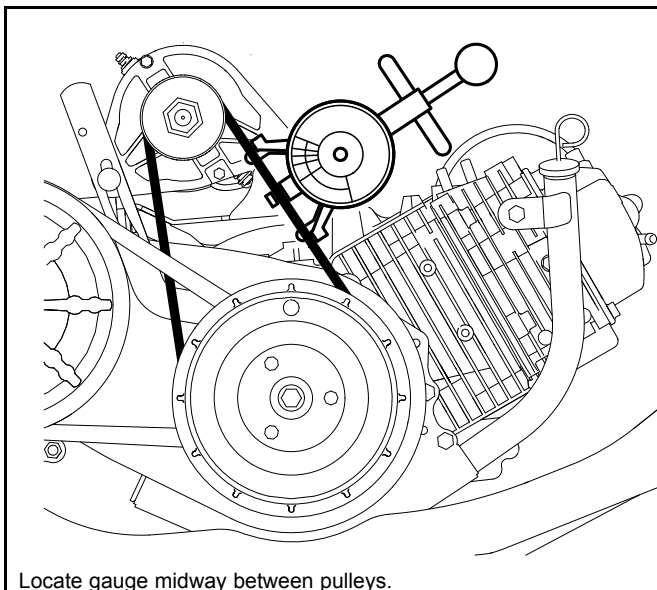

Locate gauge midway between pulleys.

2724

Figure 20-15 Belt Tension Gauge

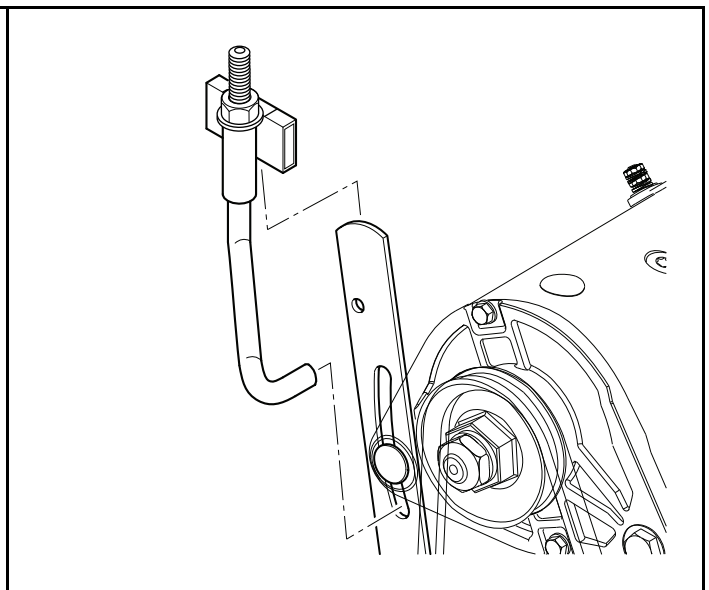

2725

Figure 20-16 Belt Tensioning Tool Installation

1. Disconnect battery and spark plug wire(s). See **Disconnecting the Battery-Gasoline Vehicles** on page 1-5.
2. Access engine compartment.
 - Remove seat and rear access panel (if equipped).
 - Raise cargo bed (if equipped).

- Use combination of above methods.
- 3. Mark a location on belt to repeat tension measurement each time. Use paint pen or permanent marker of light color.
- 4. **For Existing Belts Only:** Verify current belt tension using Universal Belt Tension Gauge (OTC® 6673 recommended) (**Figure 20-15, Page 20-13**). Proper tension for a used starter/generator belt is 75 to 85 lbf (334 to 378 N).
 - If belt tension is within accepted range, no further action is needed. Connect battery and spark plug wire(s). **See Connecting the Battery-Gasoline Vehicles on page 1-5.**
 - If belt tension is not within accepted range, continue procedure. **See following NOTE.**

NOTE: To expedite procedure for existing belt and avoid need for a pry bar, first install belt tension tool and then loosen starter/generator mounting hardware.

5. Tighten starter/generator mounting hardware (4 and 7) finger-tight (**Figure 20-13, Page 20-12**).
6. Install belt tension tool (P/N 102570401).
 - 6.1. Carefully insert pry bar between starter/generator and bracket.
 - 6.2. Carefully lift starter up until tension tool can be installed as shown over the slotted adjustment bracket (**Figure 20-16, Page 20-13**). Note orientation of tension tool on the slotted adjustment bracket and how the threaded J-bolt is inserted into the slot under the starter/generator mounting ear.

NOTE: In some cases, the threaded J-bolt of the belt tension tool does not have enough length to consistently fit under the starter/generator mounting ear. Fit can be greatly improved by modifying the tension tool using the following procedure.

- Remove nut and J-bolt from bracket.
 - Grind or cut 3/8 to 1/2 inch (9.5 to 12.7 mm) from bracket as shown to increase the effective length of the J-bolt (**Figure 20-17, Page 20-14**).
 - Install J-bolt and nut into bracket.
- 6.3. Remove pry bar.

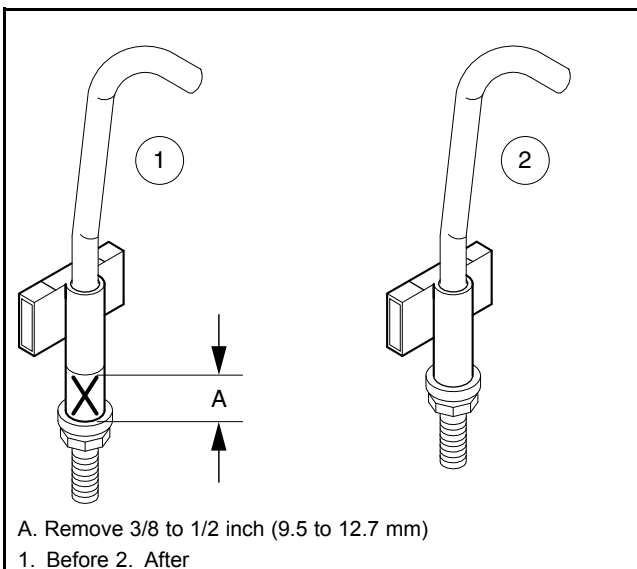

2726

Figure 20-17 Belt Tension Tool Modification (If Necessary)

7. Tension belt.

7.1. Tighten nut on belt tension tool 1/2 turn and check belt tension with gauge (**Figure 20-15, Page 20-13**).

NOTE: To prevent errors in measurement caused by residual tension, ensure to loosen, then reapply, the Universal Belt Tension gauge between measurements.

7.2. Continue to tighten in 1/2 turn increments until proper belt tension is achieved.
– Proper tension for a **used** starter/generator belt is 75 to 85 lbf (334 to 378 N).
– Proper tension for a **new** starter/generator belt is 120 to 130 lbf (534 to 578 N).

8. Seat the belt.

8.1. Remove all other tools.

8.2. The belt tension tool can be temporarily left in place.

8.3. Connect battery only. **DO NOT CONNECT SPARK PLUG WIRE. See Connecting the Battery-Gasoline Vehicles on page 1-5. See following WARNING.**

⚠ WARNING

- **Remove pry bar before starting engine.**
- **Ensure clearance between F2 terminal and starter/generator bracket before starting engine.**

8.4. Engage starter and crank engine a minimum of 5 seconds and a maximum of 15 seconds to fully seat the belt into pulleys and help eliminate any slack.

9. Repeat step 7.

10. Maintain tension and tighten adjustment nut (4) to 15 to 18 ft·lb (20 to 24.5 N·m). Tighten hex nuts (7) to 20 to 25 ft·lb (27 to 34 N·m) (**Figure 20-13, Page 20-12**).

11. Remove belt tension tool.

12. Confirm proper belt tension with a final measurement.

13. Connect spark plug wire.

VOLTAGE REGULATOR

See General Warnings on page 1-1.

TESTING THE VOLTAGE REGULATOR

See Test Procedure 13 – Voltage Regulator on page 18-32.

VOLTAGE REGULATOR REMOVAL

1. Disconnect battery and spark plug wire(s). **See Disconnecting the Battery-Gasoline Vehicles on page 1-5.**
2. Remove the electrical component box cover.
3. Disconnect the voltage regulator red wire (1) at the large post on the solenoid, the yellow wire (4) at the bullet connector, and the black wire (7) from the (NO) terminal of the kill limit switch and at the battery frame ground (**Figure 20-18, Page 20-16**).
4. Remove the voltage regulator mounting screw (8) and remove the voltage regulator (9).

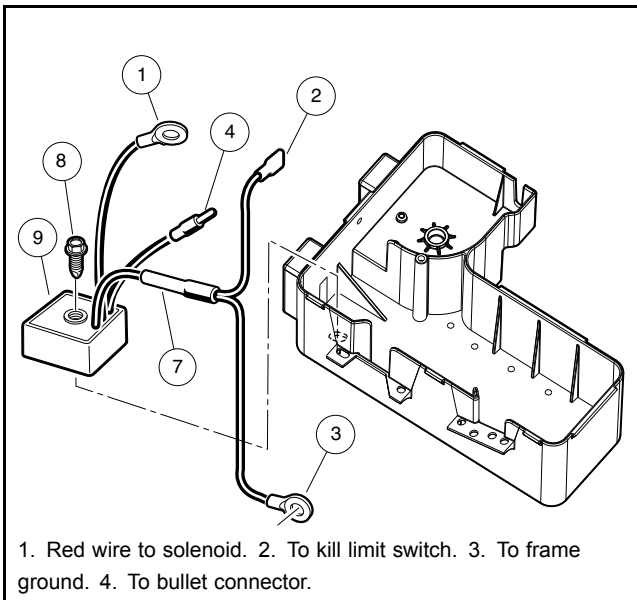

2973

Figure 20-18 Voltage Regulator

VOLTAGE REGULATOR INSTALLATION

1. Position the voltage regulator (9) in the electrical component box and install the mounting screw (8) (**Figure 20-18, Page 20-16**). Tighten screw to 23 in·lb (2.6 N·m).
2. Connect the voltage regulator red wire (1) at the large post on the solenoid, the yellow wire (4) at the bullet connector, and the black wire (7) at the battery frame ground (**Figure 20-18, Page 20-16**).
3. Install snap-on electrical component box cover. Be sure to firmly press down all corners. Install screw and tighten to 18 in·lb (2 N·m).
4. Connect battery and spark plug wire(s). **See Connecting the Battery-Gasoline Vehicles on page 1-5.**
5. Place Forward/Reverse handle in NEUTRAL and place the neutral lockout switch in the MAINTENANCE position. Start the engine and check regulator for proper functioning as described in the voltage regulator test procedure. **See Voltage Regulator on page 18-32.**

ENGINE CONTROL UNIT (ECU)

CAUTION

- The Engine Control Unit (ECU) and Throttle Body are to be purchased as one unit. They are matched pairs with matching serial numbers. Do not mix an ECU with another Throttle Body of a different serial number. Doing so violates emissions standards and warranty.

The ECU is located in the engine compartment.

TESTING THE ENGINE CONTROL UNIT

See Test Procedure 4 – EFI System (ECU and Sensors) on page 18-22.

ENGINE CONTROL UNIT REMOVAL

1. Disconnect battery. **See Disconnecting the Battery-Gasoline Vehicles on page 1-5.**
2. Remove ECU mounting plate bolts.
3. Disconnect gray and black wire connectors.

ENGINE CONTROL UNIT INSTALLATION

WARNING

- To prevent damage to the ECU, never mix the black and gray connectors that attach to it. The black connector is tethered to the ECU mounting plate to help prevent accidentally installing it in the gray port.
1. Mount ECU to plate with bolts and tighten to 108 in·lb (12.2 N·m).
 2. Install gray connector to the gray port on the ECU. **See preceding WARNING.**
 3. Install black connector to the black port on the ECU.
 4. Connect the battery. **See Connecting the Battery-Gasoline Vehicles on page 1-5.**

KEY SWITCH

See General Warnings on page 1-1.

TESTING THE KEY SWITCH

See Test Procedure 5 – Key Switch (Start Circuit) on page 18-25.

See Test Procedure 6 – Key Switch (Engine Kill Circuit) on page 18-26.

KEY SWITCH REMOVAL

1. Disconnect the batteries and spark plug.
2. Remove instrument panel. **See Instrument Panel Removal on page 4-10.**

NOTE: Take care to prevent key switch terminals and wires from touching the metal frame around the dash.

3. Disconnect the wires from the key switch. Do not allow wires to touch.
4. From the back of the instrument panel, push down on the retaining tabs surrounding the key switch (3) and remove the key switch cap (6). Using a 1-inch socket, hold the key switch (3) and remove the switch retaining nut (5) from the outside of the instrument panel (**Figure 20-19, Page 20-18**).

KEY SWITCH INSTALLATION

1. Position the key switch (3) and key switch washer (1) in the instrument panel, then install and tighten the key switch nut (5) to 35 to 45 in·lb (4 to 5 N·m). Install key switch cap (6) into instrument panel, align the bent washer tab with the slot in the plastic (**Figure 20-19, Page 20-18**).
2. Refer to the wiring diagram to connect the wires to the key switch terminals. **See Wiring Diagrams, Section 18, Page 18-8.**
3. Install instrument panel. **See Instrument Panel Installation on page 4-10.**
4. Connect the battery and spark plug.

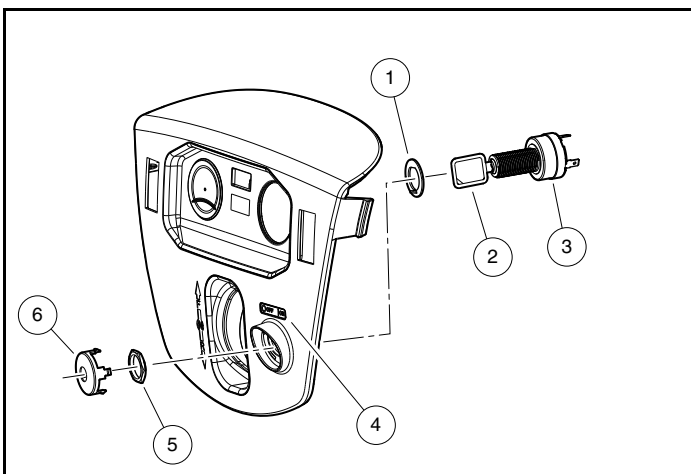

2931

Figure 20-19 Key Switch

MAINTENANCE/OPERATE SWITCH

TESTING THE MAINTENANCE/OPERATE SWITCH

See Test Procedure 9 – Maintenance/Operate Switch – Pedal-Start Vehicles on page 18-28.

MAINTENANCE/OPERATE SWITCH REMOVAL

1. Disconnect the battery and spark plug wire(s).
2. Using a 5/8 inch (16 mm) wrench, remove maintenance/operate boot/hex nut.
3. Remove maintenance/operate switch from bracket.
4. Disconnect the two spade terminals and remove switch.

MAINTENANCE/OPERATE SWITCH INSTALLATION

1. Connect the three spade terminals (**Figure 18-12, Page 18-28**).
2. Make sure groove switch is aligned with tang on bracket and install switch. Tighten maintenance/operate switch boot/hex nut to 16 in·lb (1.8 N·m).
3. Connect the battery.

NEUTRAL LOCKOUT LIMIT SWITCH

See General Warnings on page 1-1.

TESTING THE NEUTRAL LOCKOUT LIMIT SWITCH

See Test Procedure 10 – Neutral Lockout Limit Switch – Pedal-Start Vehicles Only on page 18-29.

NEUTRAL LOCKOUT LIMIT SWITCH REMOVAL

1. Turn the key switch OFF and remove the key. Place the Forward/Reverse handle in the NEUTRAL position. Chock the wheels.
2. Disconnect battery and spark plug wire(s). **See Disconnecting the Battery-Gasoline Vehicles on page 1-5.**
3. Disconnect the 3-wire connector from the neutral lockout limit switch (1) located on the transaxle.
4. Remove two nuts (3) and washers (4) from the neutral lockout limit switch (1) and slide the limit switch off of the screws.

NEUTRAL LOCKOUT LIMIT SWITCH INSTALLATION

1. Install the limit switch (1) with washers (4) and nuts (3) and tighten to 5 in·lb (0.6 N·m). Move the Forward/Reverse handle to make sure the switch actuates. **See following CAUTION.**

CAUTION

- **Do not overtighten the retaining nuts. If the nuts are overtightened, limit switches could be damaged.**

2. Connect the 3-wire connector to the neutral lockout limit switch lead.
3. Connect battery and spark plug wire(s). **See Connecting the Battery-Gasoline Vehicles on page 1-5.**
4. Test drive the vehicle in both forward and reverse for proper operation.

SOLENOID

See General Warnings on page 1-1.

TESTING THE SOLENOID

See Test Procedure 8 – Solenoid on page 18-27.

SOLENOID REMOVAL

1. Disconnect battery and spark plug wire(s). **See Disconnecting the Battery-Gasoline Vehicles on page 1-5.**
2. Remove electrical component box cover (**Figure 20-20, Page 20-23**).
3. Disconnect all the wires from the solenoid.
4. Remove the two screws securing the solenoid in place. Remove the solenoid.

SOLENOID INSTALLATION

1. Install the solenoid in the electrical component box (**Figure 20-20, Page 20-23**). Use two screws to secure the solenoid to the box and tighten to 14 in·lb (1.6 N·m).
2. Connect all wires as indicated. **See Wiring Diagrams on page 18-8.**
 - 2.1. Connect the 4-gauge white wire from the starter/generator, the 18-gauge white wire from the fuel gauge/hour meter, and the 18-gauge red wire from the voltage regulator to the large post on the solenoid.
 - 2.2. Connect the 4-gauge red wire from the positive (+) battery terminal and the 10-gauge red wire and 16-gauge orange wire from the fuse blocks to the other large post on the solenoid.
 - 2.3. Connect the 18-gauge orange wire from accelerator pedal limit switch to small post on the solenoid.
 - 2.4. Connect the 18-gauge blue wire from the key switch to the other small post on the solenoid.
3. Tighten the hex nuts on the large solenoid posts to 60 in·lb (6.8 N·m). Tighten the nuts on the small solenoid posts to 22 in·lb (2.5 N·m).
4. Install the electrical box cover.
5. Connect battery and spark plug wire(s). **See Connecting the Battery-Gasoline Vehicles on page 1-5.**

FUSE

See General Warnings on page 1-1.

ATC-style fuses are located inside the electrical component box near the battery.

ATM-style fuses are located on the main wire harness in front of the engine.

TESTING THE FUSE

See Test Procedure 2 – Fuses on page 18-19.

FUSE REMOVAL

1. Disconnect battery. **See Disconnecting the Battery-Gasoline Vehicles on page 1-5.**
2. **ATC Fuse Only:** Remove electrical component box cover cover.
ATM Fuse Only: Remove fuse holder cover.
3. Remove the fuse from the fuse block.

FUSE INSTALLATION

1. Install the fuse. **See following WARNING.**

WARNING

- **If a fuse is blown, determine the cause of the failure and make necessary repairs before installing a new fuse. Use the appropriately rated fuse; if a fuse with a higher amp rating is used, damage to the vehicle electrical system may occur.**
2. **ATC Fuse Only:** Install the snap-on electrical box cover by pressing down firmly on all corners and install the screw, tightening to 18 in·lb (2 N·m).
ATM Fuse Only: Install the fuse holder cover.
 3. Connect battery. **See Connecting the Battery-Gasoline Vehicles on page 1-5.**

KILL LIMIT SWITCH

See General Warnings on page 1-1.

TESTING THE KILL LIMIT SWITCH

See Test Procedure 14 – Kill Limit Switch – Pedal-Start Vehicles Only on page 18-33.

KILL LIMIT SWITCH REMOVAL

1. Disconnect battery and spark plug wire(s). **See Disconnecting the Battery-Gasoline Vehicles on page 1-5.**
2. Remove electrical component box cover (1) (**Figure 20-20, Page 20-23**).
3. Remove the two nuts (9) and washers (10) securing the accelerator pedal limit switch (11). Do not disconnect the wires attached to accelerator pedal limit switch (11) (**Figure 20-20, Page 20-23**).
4. Disconnect the wires from the kill limit switch (12).
5. Remove the kill limit switch (12).

KILL LIMIT SWITCH INSTALLATION

1. Connect the white/black wire to the common (COM) terminal and the blue wire to the normally open (NO) terminal of the kill limit switch (12) and place the switch on the mounting screws located in the electrical component box (**Figure 20-20, Page 20-23**). Place the accelerator limit switch (11) on the mounting screws located in the electrical component box.
2. Secure the switches using two washers (10) and two nuts (9). Tighten to 5 in·lb (0.6 N·m). **See following CAUTION.**

⚠ CAUTION

- **Do not overtighten the retaining nuts. If the nuts are overtightened, limit switches could be damaged.**
3. Press and release the accelerator pedal to make sure that both switches are being activated when the pedal is released.
 4. Install electrical component box cover (1) (**Figure 20-20, Page 20-23**). Be sure to press down firmly all corners. Install screw (20) and tighten to 18 in·lb (2 N·m).
 5. Connect battery and spark plug wire(s). **See Connecting the Battery-Gasoline Vehicles on page 1-5.**

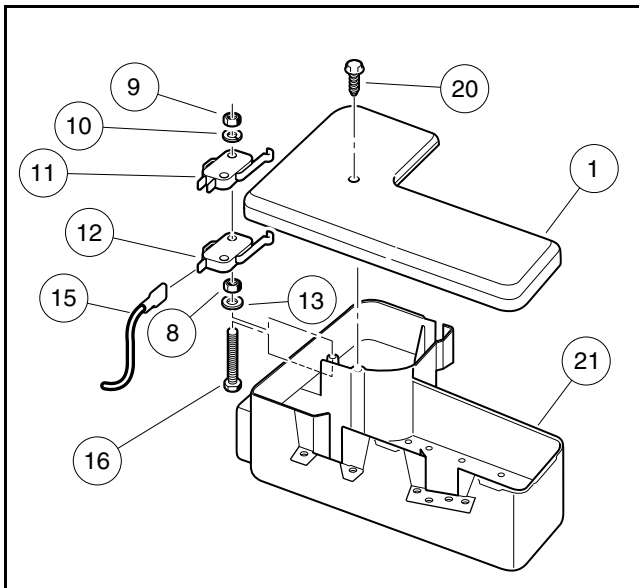

2948

Figure 20-20 Accelerator Starter and Kill Limit Switches

REVERSE WARNING BUZZER

See General Warnings on page 1-1.

TESTING THE REVERSE WARNING BUZZER

See Test Procedure 17 – Reverse Buzzer and Reverse Buzzer Limit Switch on page 18-36.

REVERSE WARNING BUZZER REMOVAL

1. Disconnect battery and spark plug wire(s). See **Disconnecting the Battery-Gasoline Vehicles** on page 1-5.
2. Remove the instrument panel. See **Instrument Panel Removal, Section 4, Page 4-10**.
3. Disconnect the wires from the reverse warning buzzer (2) (**Figure 20-21, Page 20-24**). Do not allow wires to touch.
4. Remove the mounting screws (1) securing the buzzer (2) to the instrument panel.

REVERSE WARNING BUZZER INSTALLATION

1. Install the screws (1) through the buzzer (2) mounting tabs and tighten to 3.5 in·lb (0.40 N·m) (**Figure 20-21, Page 20-24**).
2. Connect the black wire from the key switch to the negative (–) terminal on the buzzer.
3. Connect the orange/white wire from the wire harness to the positive (+) terminal on the buzzer.
4. Install instrument panel. See **Instrument Panel Installation, Section 4, Page 4-10**. Be sure that the key switch terminals cannot touch the frame and that the panel is properly seated and snapped in place.
5. Connect battery and spark plug wire(s). See **Connecting the Battery-Gasoline Vehicles** on page 1-5.

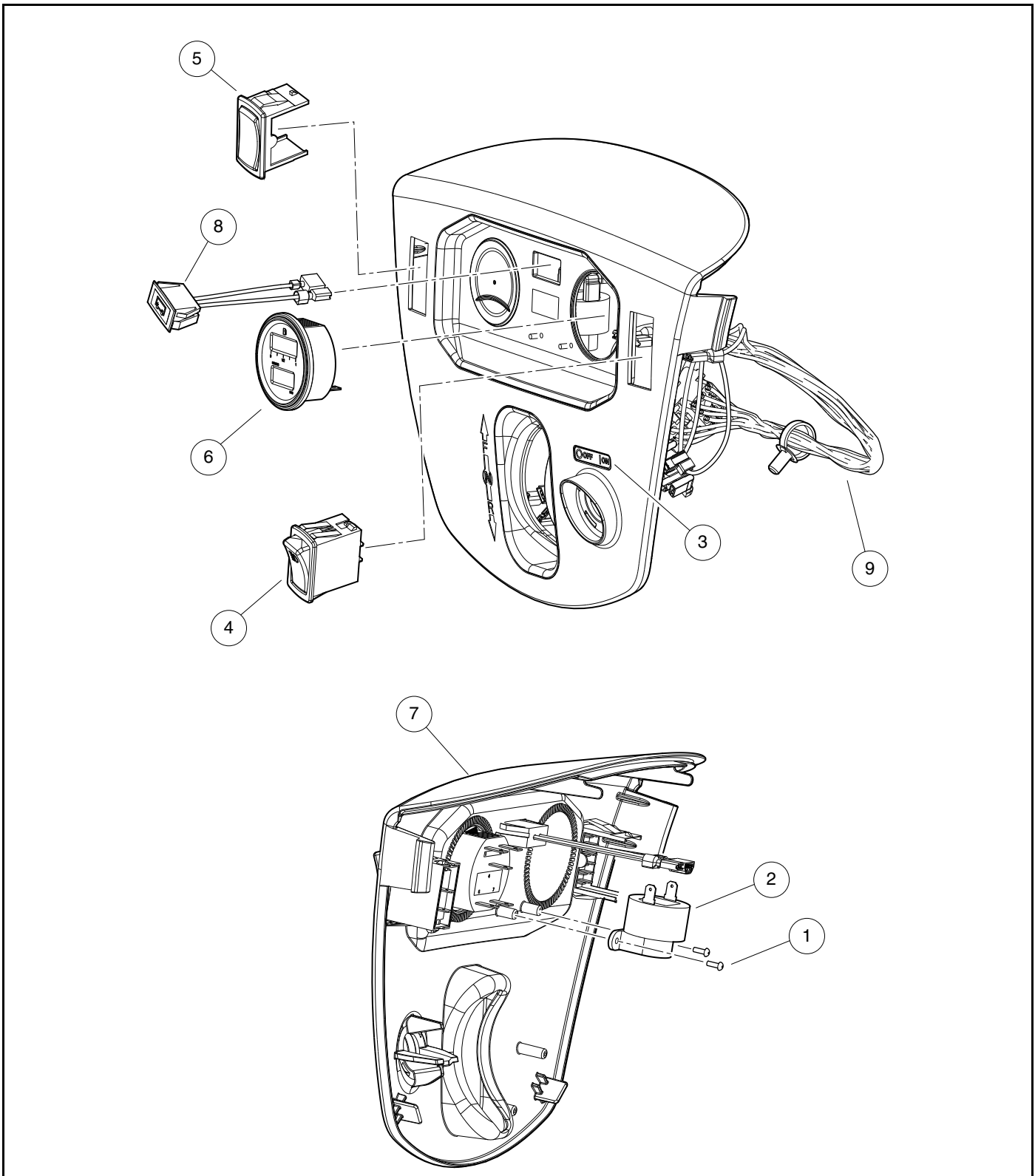

3003

Figure 20-21 Instrument Panel Switches

REVERSE BUZZER LIMIT SWITCH

See General Warnings on page 1-1.

TESTING THE REVERSE BUZZER LIMIT SWITCH

See Test Procedure 17 – Reverse Buzzer and Reverse Buzzer Limit Switch on page 18-36.

REVERSE BUZZER LIMIT SWITCH REMOVAL

1. Disconnect battery and spark plug wire(s). **See Disconnecting the Battery-Gasoline Vehicles on page 1-5.**
2. Cut the wire tie that retains the limit switch leads to the instrument panel harness.
3. Disconnect the wire connector from the reverse buzzer limit switch (3) located on the back of the Forward/Reverse shifter assembly (**Figure 20-22, Page 20-26**).
4. Remove the nuts (4) and washers (5) from the reverse buzzer switch (3) and slide the reverse buzzer switch off of the screws (2).

REVERSE BUZZER LIMIT SWITCH INSTALLATION

1. Install the reverse buzzer switch (3) with two screws (2) (**Figure 20-22, Page 20-26**), that attach the buzzer to the shifter assembly. Install washers (5) and tighten nuts (4) to 5 in·lb (0.6 N·m). **See following CAUTION.**

CAUTION

- **Do not overtighten the retaining nuts. If the nuts are over tightened, limit switches could be damaged.**
2. Place the Forward/Reverse handle in REVERSE and make sure that both switches actuate.
 3. Connect the two wire connector to the reverse buzzer limit switch (3).
 4. Connect battery and spark plug wire(s). **See Connecting the Battery-Gasoline Vehicles on page 1-5.**
 5. Turn the key switch to the ON position. Shift the Forward/Reverse handle to the REVERSE position. The buzzer should sound.

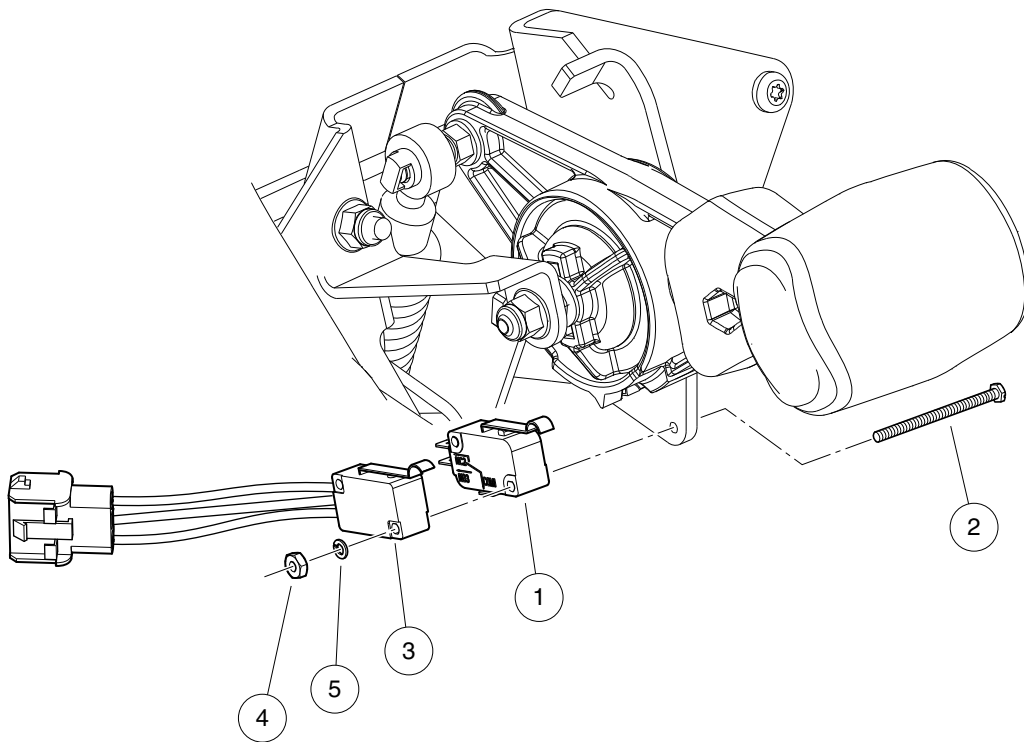

3001

Figure 20-22 Forward/Reverse Assembly Switches

LOW OIL WARNING LIGHT

See General Warnings on page 1-1.

TESTING THE LOW OIL WARNING LIGHT

See Test Procedure 18 – Low Oil Warning Light (LED) on page 18-36.

LOW OIL WARNING LIGHT REMOVAL

1. Disconnect battery and spark plug wire(s). See **Disconnecting the Battery-Gasoline Vehicles on page 1-5**.
2. Remove the instrument panel. See **Instrument Panel Removal, Section 4, Page 4-10**.
3. Disconnect the wires from the low oil warning light (6) (**Figure 20-21, Page 20-24**). Do not allow wires to touch.
4. Press the retaining tabs and remove the low oil warning light from the instrument panel.

LOW OIL WARNING LIGHT INSTALLATION

1. Push a new unit into hole in the instrument panel until plastic tabs engage instrument panel (**Figure 20-21, Page 20-24**).
2. Connect yellow wire to positive (+) terminal and black wire to negative (-) terminal of the low oil warning light.
3. Install the instrument panel. See **Instrument Panel Installation, Section 4, Page 4-10**. Be sure that key switch terminals cannot touch the frame and that panel is properly seated and snapped in place.
4. Connect battery and spark plug wire(s). See **Connecting the Battery-Gasoline Vehicles on page 1-5**.

FUEL GAUGE/HOUR METER

See General Warnings on page 1-1.

TESTING THE FUEL GAUGE/HOUR METER

See Test Procedure 23 – Fuel Gauge on page 18-40. Also see Test Procedure 24 – Hour Meter on page 18-41.

GENERAL INFORMATION

With the key switch in the OFF position, the fuel gauge field is blank; however, the hour meter field is always ON. When the key switch is turned to ON, the fuel gauge field activates. The fuel gauge initially registers full before indicating the actual fuel level.

The hour meter displays the number of hours of use in increments of 0.1 (one tenth) hour, but does not record additional time unless the key switch is in the ON position and the engine is on. When recording, the hourglass icon on the left blinks.

FUEL GAUGE/HOUR METER REMOVAL

1. Disconnect battery and spark plug wire(s). See **Disconnecting the Battery-Gasoline Vehicles on page 1-5**.
2. Remove the instrument panel. See **Instrument Panel Removal, Section 4, Page 4-10**.
3. Disconnect the wires from the fuel gauge/hour meter (6). Do not allow wires to touch. (**Figure 20-21, Page 20-24**).

4. Alternate pulling the lower and upper tabs away from the gauge housing to remove clip. Pull gauge/meter from the instrument panel.

FUEL GAUGE/HOUR METER INSTALLATION

1. Install a new fuel gauge/hour meter (6) into the hole in the instrument panel until the flange seats against the instrument panel (**Figure 20-21, Page 20-24**).
2. Connect the wires to the fuel gauge/hour meter. **See Wiring Diagrams on page 18-8.**
3. Install the instrument panel. **See Instrument Panel Installation, Section 4, Page 4-10.** Be sure that key switch terminals cannot touch the frame and that panel is properly seated and snapped in place.
4. Connect battery and spark plug wire(s). **See Connecting the Battery-Gasoline Vehicles on page 1-5.**

FUEL LEVEL SENDING UNIT

See General Warnings on page 1-1.

The fuel level sending unit is an integral part of the fuel pump module and is not replaceable. Thoroughly test the fuel level sending unit before replacing the fuel pump module.

TESTING THE FUEL LEVEL SENDING UNIT

See Test Procedure 22 – Fuel Level Sending Unit on page 18-39.

OIL LEVEL SENSOR

See General Warnings on page 1-1.

TESTING THE OIL LEVEL SENSOR

See Test Procedure 19 – Oil Level Sensor on page 18-37.

OIL LEVEL SENSOR REMOVAL

See Oil Level Sensor Removal on page 22-12.

OIL LEVEL SENSOR INSTALLATION

See Oil Level Sensor Installation on page 22-12.

VOLTAGE LIMITER

See General Warnings on page 1-1.

TESTING THE VOLTAGE LIMITER

See Test Procedure 27 – Voltage Limiter on page 18-43.

VOLTAGE LIMITER REMOVAL

NOTE: Battery will charge reducing the voltage going to accessories.

1. Turn the key switch OFF and remove the key. Place the Forward/Reverse handle in the NEUTRAL position. Chock the wheels.
2. Disconnect battery and spark plug wire(s). **See Disconnecting the Battery-Gasoline Vehicles on page 1-5.**
3. Remove the cowl. **See Cowl Removal, Section 4, Page 4-5.**
4. The voltage limiter is located on the driver side cowl frame.
5. Disconnect wires from the voltage limiter (1). Do not allow wires to touch (**Figure 20-23, Page 20-29**).
6. Remove the mounting hardware (2) from the voltage limiter and remove from vehicle.

VOLTAGE LIMITER INSTALLATION

1. Mount the voltage limiter to the driver side frame using the mounting hardware and tighten to 25 in·lb (2.8 N·m) (**Figure 20-23, Page 20-29**).
2. Connect the black wire from harness to the black wire from limiter.
3. Connect the green wire from the harness to the green wire from the limiter.
4. Install the cowl. **See Cowl Installation, Section 4, Page 4-5.**
5. Connect battery and spark plug wire(s). **See Connecting the Battery-Gasoline Vehicles on page 1-5.**

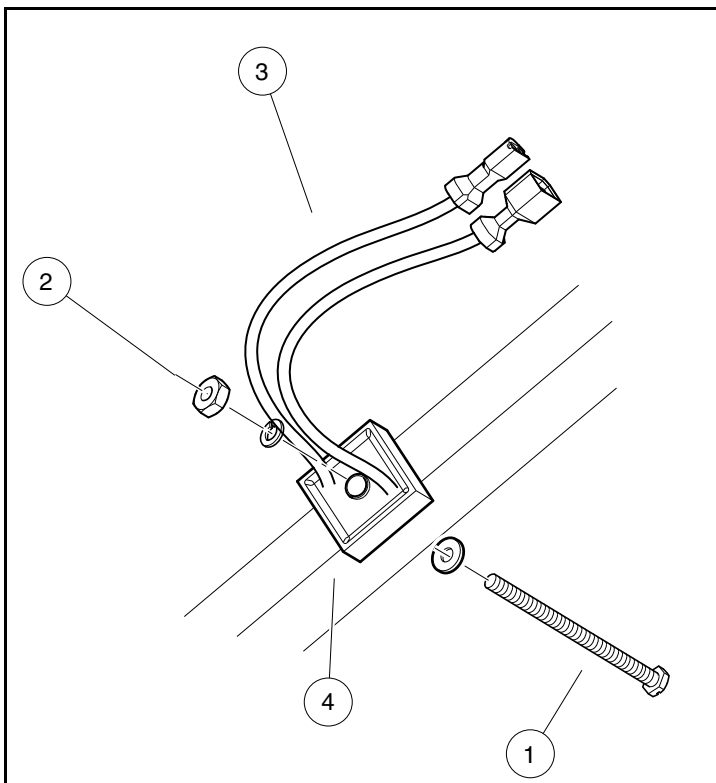

3002

Figure 20-23 Voltage Limiter

HEADLIGHT SWITCH

See General Warnings on page 1-1.

TESTING THE LIGHT SWITCH

See Test Procedure 25 – Light Switch on page 18-42.

HEADLIGHT SWITCH REMOVAL

1. Remove the instrument panel. **See Instrument Panel Removal, Section 4, Page 4-10.**
2. Disconnect the wires from the light switch (4 and 9) **(Figure 20-21, Page 20-24).**
3. Collapse the tabs and un-snap the light switch(4) from instrument panel.

HEADLIGHT SWITCH INSTALLATION

1. Connect the wires to the light switch (4 and 9) **(Figure 20-21, Page 20-24).**
2. Reinsert light switch (4) to instrument panel.
3. Install the instrument panel. **See Instrument Panel Installation on page 4-10.** Be sure that key switch terminals cannot touch the frame and the instrument panel is properly seated and snapped in place.
4. Connect battery and spark plug wire(s). **See Connecting the Battery-Gasoline Vehicles on page 1-5.**

HEADLIGHTS

See General Warnings on page 1-1.

TESTING THE HEADLIGHT SOCKET

See Test Procedure 26 – Voltage at Headlight Socket on page 18-42.

HEADLIGHT BEZEL REMOVAL

1. Disconnect the batteries and discharge the controller. **Disconnecting the Batteries – Electric Vehicles on page 1-4**
2. Remove the cowl. **See Cowl Removal, Section 4, Page 4-5.**
3. Remove the front fenders. **See Front Bumper and Side Fender Removal, Section 4, Page 4-9.**
4. Loosen and remove the M6 self-tapping bolts (3) that attach the bezel (1) to the vehicle frame. **(Figure 20-24, Page 20-32).**

HEADLIGHT BEZEL INSTALLATION

1. Install bezel (1) to vehicle frame.
2. Install the three M6 self-tapping bolts (3) that attach the bezel onto frame. Tighten to 44 in·lb (5 N·m).
3. Install the front fenders. **See Front Bumper and Side Fender Installation, Section 4, Page 4-9.**
4. Install the cowl. **See Cowl Installation, Section 4, Page 4-5.**
5. Connect the batteries. **See Connecting the Batteries – Electric Vehicles, Section 1, Page 1-4.**

HEADLIGHT BULB REMOVAL (HALOGEN)

1. Disconnect the batteries. **See Disconnecting the Batteries – Electric Vehicles, Section 1, Page 1-4.**
2. Remove cowl. **See Cowl Removal, Section 4, Page 4-5.**
3. Remove front fenders. **See Front Bumper and Side Fender Removal, Section 4, Page 4-9.**
4. Rotate the bulb (4) (but do not touch) in a 90-degree angle and pull out of lens assembly (5). **(Figure 20-24, Page 20-32).**

HEADLIGHT BULB INSTALLATION (HALOGEN)

1. Install bulb (4) (but do not touch) into socket, install into lens assembly (5). **(Figure 20-24, Page 20-32).**
2. Connect the batteries. **See Connecting the Batteries – Electric Vehicles on page 1-4.**
3. Install front fenders. **See Front Bumper and Side Fender Installation, Section 4, Page 4-9.**
4. Install cowl. **See Cowl Installation, Section 4, Page 4-5.**

HEADLIGHT BULB REMOVAL (LED)

1. Disconnect the batteries.
2. Remove cowl. **See Cowl Removal, Section 4, Page 4-5.**
3. Remove front fenders. **See Front Bumper and Side Fender Removal, Section 4, Page 4-9.**
4. Remove the three screws (2) and pull bulb assembly (6) out of bezel (1). **(Figure 20-24, Page 20-32)**

HEADLIGHT BULB INSTALLATION (LED)

1. Install bulb assembly (6) into bezel (1) and secure with screws (2). **(Figure 20-24, Page 20-32)**
2. Connect the batteries. **See Connecting the Batteries – Electric Vehicles on page 1-4.**
3. Install front fenders. **See Front Bumper and Side Fender Installation, Section 4, Page 4-9.**
4. Install cowl. **See Cowl Installation, Section 4, Page 4-5.**

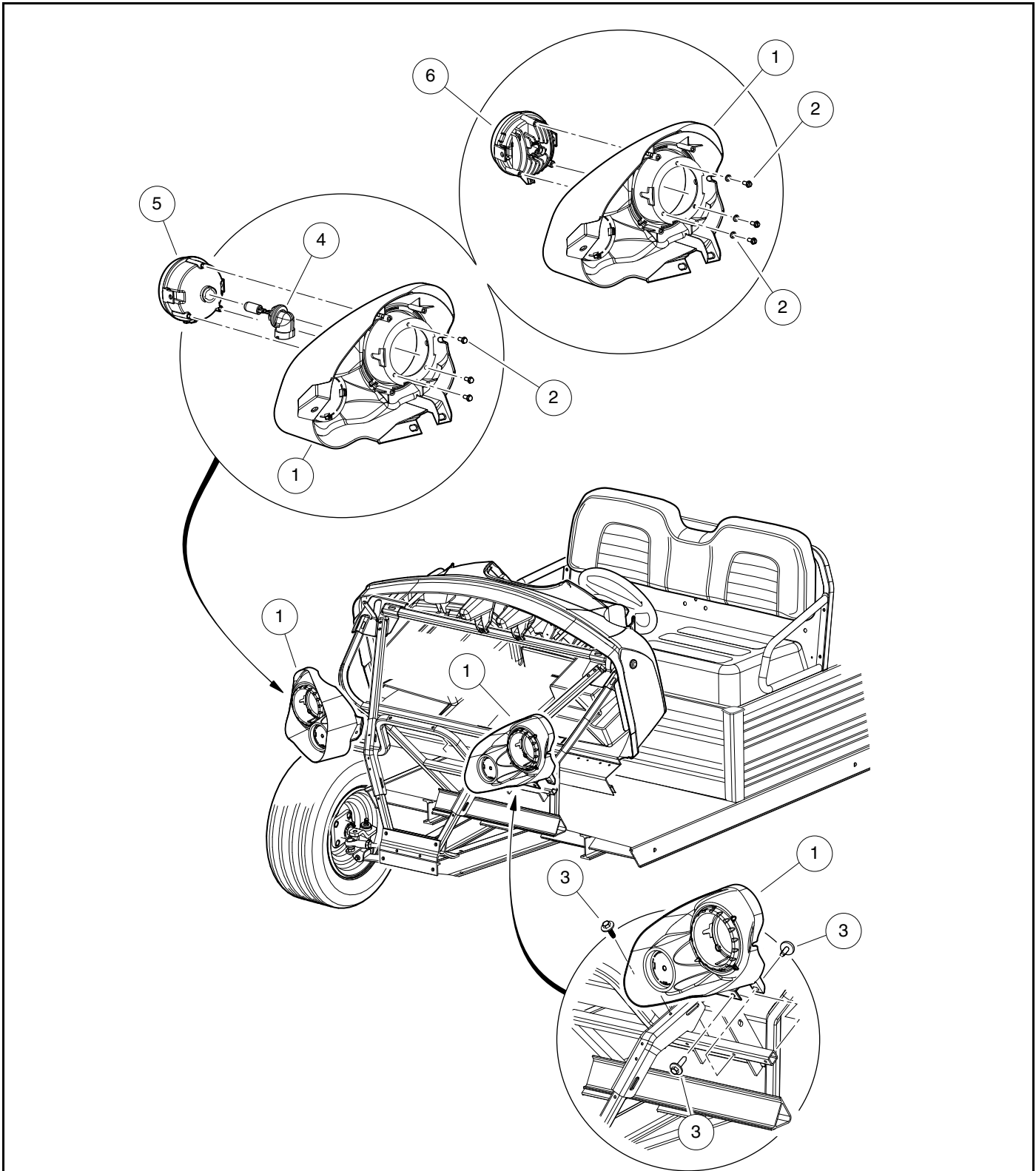

2993

Figure 20-24 Headlight Assembly

BATTERY

See General Warnings on page 1-1.

▲ DANGER

- Due to the danger of an exploding battery, wear a full face shield and rubber gloves when working on or near batteries.
- **Battery – Explosive gases! Do not smoke. Keep sparks and flames away from the vehicle and service area. Ventilate when charging or operating vehicle in an enclosed area. Wear a full face shield and rubber gloves when working on or near batteries.**
- Tools, wires, and metal objects can cause sparks when shorted across a battery.
- Follow all instructions carefully when working with batteries.
- Charge battery in a well-ventilated area only.
- **Battery – Poison! Contains acid! Causes severe burns. Avoid contact with skin, eyes, or clothing. Antidotes:**
 - External: Flush with water. Call a physician immediately.
 - Internal: Drink large quantities of milk or water followed with milk of magnesia or vegetable oil. Call a physician immediately.
 - Eyes: Flush with water for 15 minutes. Call a physician immediately.

▲ WARNING

- Do not jump start a dead battery using another battery and jumper cables.

GENERAL INFORMATION

See preceding **DANGER** and **WARNING** statements.

Gasoline vehicles are equipped with 12-volt top-post battery. When changing a 12-volt battery in any gasoline-powered vehicle, the same size battery with adequate amperage ratings should be used as a replacement.

A group 26, top-post battery, with a 525 cold cranking amp rating and a reserve capacity of at least 85 minutes is recommended. The group 26 classification indicates battery size: 8 inches W x 6-3/4 inches D x 7 inches H (20.3 cm W x 17.2 cm D x 17.8 cm H). It is important to use the proper size to ensure that the battery clamp will fit correctly.

TESTING THE BATTERY

See Test Procedure 1 – Battery on page 18-17.

See Test Procedure 20 – Battery Test (Under Load) on page 18-37.

PREVENTIVE MAINTENANCE

1. To keep the battery in good operating condition, remove any corrosion immediately. Post connections should be clean and tight. Any frayed or worn wires should be replaced. After all cables have been connected and properly

tightened to 41 in·lb (4.3 N·m), coat terminals with Battery Terminal Protector Spray (CC P/N 1014305) to prevent future corrosion. **See preceding WARNINGS and following CAUTION.**

⚠ CAUTION

- **If battery wire terminals are damaged or corroded, replace or clean them as necessary. Failure to do so may cause them to overheat during operation and could result in a fire, property damage, or personal injury.**
2. The battery should be kept clean and dry to prevent self-discharge. Any dirt, grime or acid spillage should be removed. Wash the battery with a bristle brush using water and bicarbonate of soda (1 cup (237 mL) baking soda per 1 gallon (3.8 L) of water). Rinse with water. Do not allow solution to enter battery through the vent cap holes. **See Self-Discharge on page 20-34.**
 3. Check battery periodically to see that it is in a full state of charge. **See Charging the Battery on page 20-35.**
 4. Keep battery hold-down clamp tight. **See Vibration Damage on page 20-34.**

SELF-DISCHARGE

Dirt and battery acid can provide a path for a small current draw that slowly discharges the battery. To prevent self-discharge, the battery should always be kept clean.

Hot weather also has an effect on a battery's self-discharge rate. The higher the temperature, the quicker a battery will discharge. In hotter climates, therefore, the battery should be checked more often. When storing the battery, keep in a cool place. **See Battery Storage on page 20-36.**

VIBRATION DAMAGE

The battery hold-down clamp should always be tight enough to keep the battery from bouncing. Battery life may be severely shortened if the clamp is too loose. Excessive vibration shortens the life of the battery. It may also cause acid to leak out of the vent caps and corrosion to build up on surrounding metal parts. The acid that is lost reduces the capacity of the battery and cannot be replaced.

BATTERY REMOVAL

See General Warnings on page 1-1. Also see DANGER at beginning of Battery topic.

1. Turn the key switch OFF and remove the key. Place the Forward/Reverse handle in the NEUTRAL position. Chock the wheels.
2. Disconnect battery and spark plug wire(s). See **Disconnecting the Battery-Gasoline Vehicles on page 1-5**.
3. Remove the battery hold-down clamp from the battery.
4. Lift the battery from the vehicle. See following **WARNING**.

⚠ WARNING

- Keep the battery in an upright position to prevent electrolyte leakage. Tipping the battery beyond a 45° angle in any direction can allow a small amount of electrolyte to leak out of the vent hole. Do not exceed this 45° angle when lifting, carrying or installing battery. The battery acid could cause severe personal injury when accidentally coming in contact with the skin or eyes, and could damage clothing.

CHARGING THE BATTERY

See General Warnings on page 1-1. Also see DANGER at beginning of Battery topic.

1. Charge the battery using an automotive type 12-volt battery charger. Follow all warnings and procedures supplied by the battery charger manufacturer.
2. Attach the positive (+) charger cable to the positive (+) battery post.
3. Attach the negative (–) charger cable to the negative (–) battery post.
4. The battery may be charged with a slow charge (3 to 10 amps) or a fast charge (20 to 30 amps). Charge until the battery voltage is greater than 12.4 volts. See following **WARNING**.

⚠ WARNING

- If the battery case feels hot (approximately 125 °F (52 °C) or more), emits gases, or fluid boils from vents, stop charging immediately. Failure to stop charging battery when any of these conditions are present could result in an explosion, personal injury and/or damage to the battery.
- Do not disconnect the charger DC leads from the battery when the charger is on. The resulting arcing between the DC leads and battery post could cause an explosion.
- If the charger must be stopped, disconnect the AC supply cord from the wall outlet before disconnecting the DC leads from the battery. Allow the battery to cool to room temperature and resume charging battery at a lower amp rate.

BATTERY INSTALLATION

See General Warnings on page 1-1. Also see DANGER at beginning of Battery topic.

1. Place the battery into the vehicle with the battery posts facing the engine.
2. Secure the battery to the vehicle with the clamp and install bolt, washer and locknut and tighten to 41 in·lb (4.3 N·m). A loose battery clamp may allow the battery to become damaged from vibration or jarring.
3. Connect battery and spark plug wire(s). See **Connecting the Battery-Gasoline Vehicles on page 1-5**.

BATTERY STORAGE

See General Warnings on page 1-1. Also see **DANGER** at beginning of Battery topic.

1. Keep the battery clean and free of corrosion. **See Preventive Maintenance on page 20-33.**
2. The battery cables should be disconnected from the battery so the battery can be connected to the charger. The battery can be left in the vehicle. Disconnect the negative (-) cable first.
3. Fully charge the battery prior to storage.
4. Store in a cool, dry area. The colder the area in which the battery is stored, the less the battery will self-discharge. A battery stored at 0 °F (-17.8 °C) will discharge very little over a four-month period. A battery stored at 80 °F (27 °C) will have to be recharged every few weeks.
5. Check the state of charge periodically. A battery that is discharged and left in a cold environment can freeze and crack. If the voltage drops below 12.4 volts, the battery should be recharged. **See following WARNING.**

⚠ WARNING

- If the battery is frozen or the container is bulged, discard battery. A frozen battery can explode.
6. The frequency of recharging required depends on the temperature of the storage area, but it is recommended that the battery be monitored for state of charge every month. Also, if the storage area is unheated in a cold climate and recharging is required, it is recommended that the area be heated to at least 60 °F (16 °C) prior to charging. The battery will not charge effectively in cold temperatures for the same reasons that it does not discharge as rapidly in cold temperatures.

CHARGING A DEAD BATTERY

See General Warnings on page 1-1. Also see **DANGER** at beginning of Battery topic.

The vehicle is equipped with a starter/generator. The generator is not designed to charge a dead battery. If the vehicle battery has become discharged, it must be charged using a properly rated automotive type charger. **See following WARNING.**

⚠ WARNING

- Do not jump-start a dead battery using another battery and jumper cables.

GROUND CABLES

NOTE: Verify that all cables (fuel tank, engine, battery, starter/generator and voltage regulator) are connected securely.

TESTING THE GROUND CABLES

See Test Procedure 3 – Ground Cables on page 18-21.

⚠ DANGER

- See General Warnings on page 1-1.

⚠ WARNING

- See General Warnings on page 1-1.

GENERAL INFORMATION

⚠ WARNING

- To prevent damage to the ECU, never mix the black and gray connectors that attach to it. The black connector is tethered to the ECU mounting plate to help prevent accidentally installing it in the gray port.

This section covers only the components that make the key-start gasoline vehicle different from the pedal-start gasoline vehicle. Use this information in addition to the **Electrical Components: Pedal-Start Gas Vehicle** section. Most components are shared between the two systems except for the following items unique to the key-start vehicle:

- **Key Switch:** Only way to start and shut off the engine.
- **Accelerator Pedal:** Is not linked to the accelerator pedal limit switch and kill limit switch in the electrical component box because these switches are omitted for key-start applications.
- **Charging Diode:** Is connected to the solenoid in the electrical component box.
- **Forward/Reverse Shifter:** Is not linked to the neutral lockout limit switch on the transaxle because this switch is omitted for key-start applications.

KEY SWITCH

See General Warnings on page 1-1.

TESTING THE KEY SWITCH

See Test Procedure 2 – Key Switch (ON Position) on page 19-7.

See Test Procedure 3 – Key Switch (START Position) on page 19-7.

See Test Procedure 6 – Key Switch (Engine Kill Circuit) on page 18-26.

KEY SWITCH REMOVAL

1. Disconnect the batteries and spark plug.
2. Remove instrument panel. **See Instrument Panel Removal on page 4-10.**

NOTE: Take care to prevent key switch terminals and wires from touching the metal frame around the dash.

3. Disconnect the wires from the key switch. Do not allow wires to touch.

4. From the back of the instrument panel, push down on the retaining tabs surrounding the key switch (3) and remove the key switch cap (6). Using a 1-inch socket, hold the key switch (3) and remove the switch retaining nut (5) from the outside of the instrument panel (**Figure 21-1, Page 21-2**).

KEY SWITCH INSTALLATION

1. Position the key switch (3) and key switch washer (1) in the instrument panel, then install and tighten the key switch nut (5) to 35 to 45 in·lb (4 to 5 N·m). Install key switch cap (6) into instrument panel, align the bent washer tab with the slot in the plastic. (**Figure 21-1, Page 21-2**).
2. Refer to the wiring diagram to connect the wires to the key switch terminals. **See Wiring Diagrams, Section 19, Page 19-2.**
3. Install instrument panel. **See Instrument Panel Installation on page 4-10.**
4. Connect the battery and spark plug.

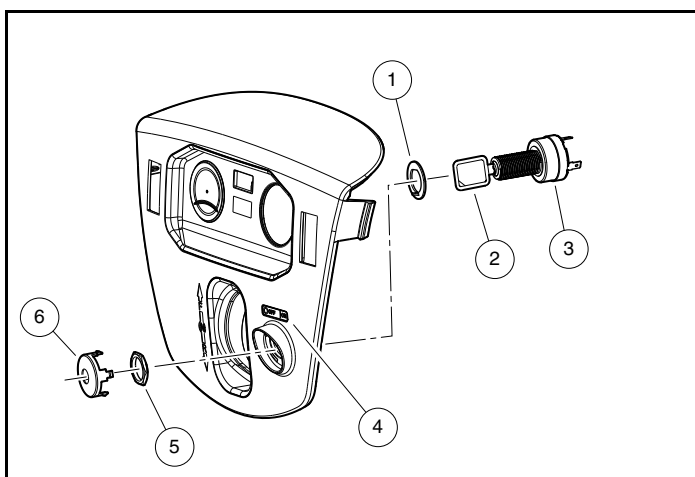

2931

Figure 21-1 Key Switch

MAINTENANCE/OPERATE SWITCH

TESTING THE MAINTENANCE/OPERATE SWITCH

See Test Procedure 5 – Maintenance/Operate Switch – Key-Start Vehicles on page 19-9.

MAINTENANCE/ OPERATE SWITCH REMOVAL

1. Disconnect the battery and spark plug wire(s).
2. Using a 5/8 inch (16 mm) wrench, remove maintenance/operation boot/hex nut.
3. Remove maintenance/operation switch from bracket.
4. Disconnect the two spade terminals and remove switch.

MAINTENANCE/OPERATE SWITCH INSTALLATION

1. Connect the two spade terminals (**Figure 19-7, Page 19-9**).
2. Make sure groove in switch is aligned with tang on bracket and install switch. Tighten maintenance/operation switch boot/hex nut (6) to 16 in·lb (1.8 N·m).
3. Connect the battery.

SOLENOID

See General Warnings on page 1-1.

TESTING THE SOLENOID

See Test Procedure 8 – Solenoid on page 18-27.

SOLENOID REMOVAL

1. Disconnect battery and spark plug wire(s). **See Disconnecting the Battery-Gasoline Vehicles on page 1-5.**
2. Remove electrical component box cover (**Figure 20-20, Page 20-23**).
3. Disconnect all the wires from the solenoid.
4. Remove the two screws securing the solenoid in place. Remove the solenoid.

SOLENOID INSTALLATION

1. Install the solenoid in the electrical component box. Use two screws to secure the solenoid to the box and tighten to 14 in·lb (1.6 N·m).
2. Connect all wires as indicated. **See Wiring Diagrams on page 19-2.**
 - 2.1. Connect the 4-gauge white wire from the starter/generator, the 18-gauge white wire from the fuel gauge/hour meter, the 18-gauge red wire from the voltage regulator, and the 10-gauge white wire from the charging diode to the large post on the solenoid.
 - 2.2. Connect the 4-gauge red wire from the positive (+) battery terminal, the 10-gauge red wire and 16-gauge orange wire from the fuse blocks, and the 10-gauge red wire from the charging diode to the other large post on the solenoid.

- 2.3. Connect the 18-gauge orange wire from accelerator pedal limit switch to small post on the solenoid.
- 2.4. Connect the 18-gauge blue wire from the key switch to the other small post on the solenoid.
3. Tighten the hex nuts on the large solenoid posts to 60 in·lb (6.8 N·m). Tighten the nuts on the small solenoid posts to 22 in·lb (2.5 N·m).
4. Install the electrical box cover.
5. Connect battery and spark plug wire(s). **See Connecting the Battery-Gasoline Vehicles on page 1-5.**

CHARGING DIODE

See General Warnings on page 1-1.

TESTING THE CHARGING DIODE

See Test Procedure 6 – Charging Diode (Generator Circuit) – Key-Start Vehicles Only on page 19-10.

CHARGING DIODE REMOVAL

1. Turn the key switch OFF and remove the key. Place the Forward/Reverse handle in the NEUTRAL position. Chock the wheels.
2. Disconnect battery and spark plug wire(s). **See Disconnecting the Battery-Gasoline Vehicles on page 1-5.**
3. Remove the screw (1) and electrical component box cover (2) (**Figure 21-2, Page 21-5**).
4. Remove the nuts (3) from the two large solenoid posts and disconnect the charging diode wires (4 and 5) from the solenoid.
- 4.1. Observe color orientation of the wires with the terminal locations on the solenoid. The 10-gauge red wire (4) from the charging diode (6) should be attached to the same terminal as the red wire (7) from the fuse block and the red wire (8) from the battery. The 10-gauge white wire (5) should be attached to the other large solenoid post, along with the red wire (9) from the voltage regulator and the white wire (10) from the starter/generator.
5. Remove the nut (11), the charging diode (6), and thermal transfer pad (12) from the chassis. Discard transfer pad (12).

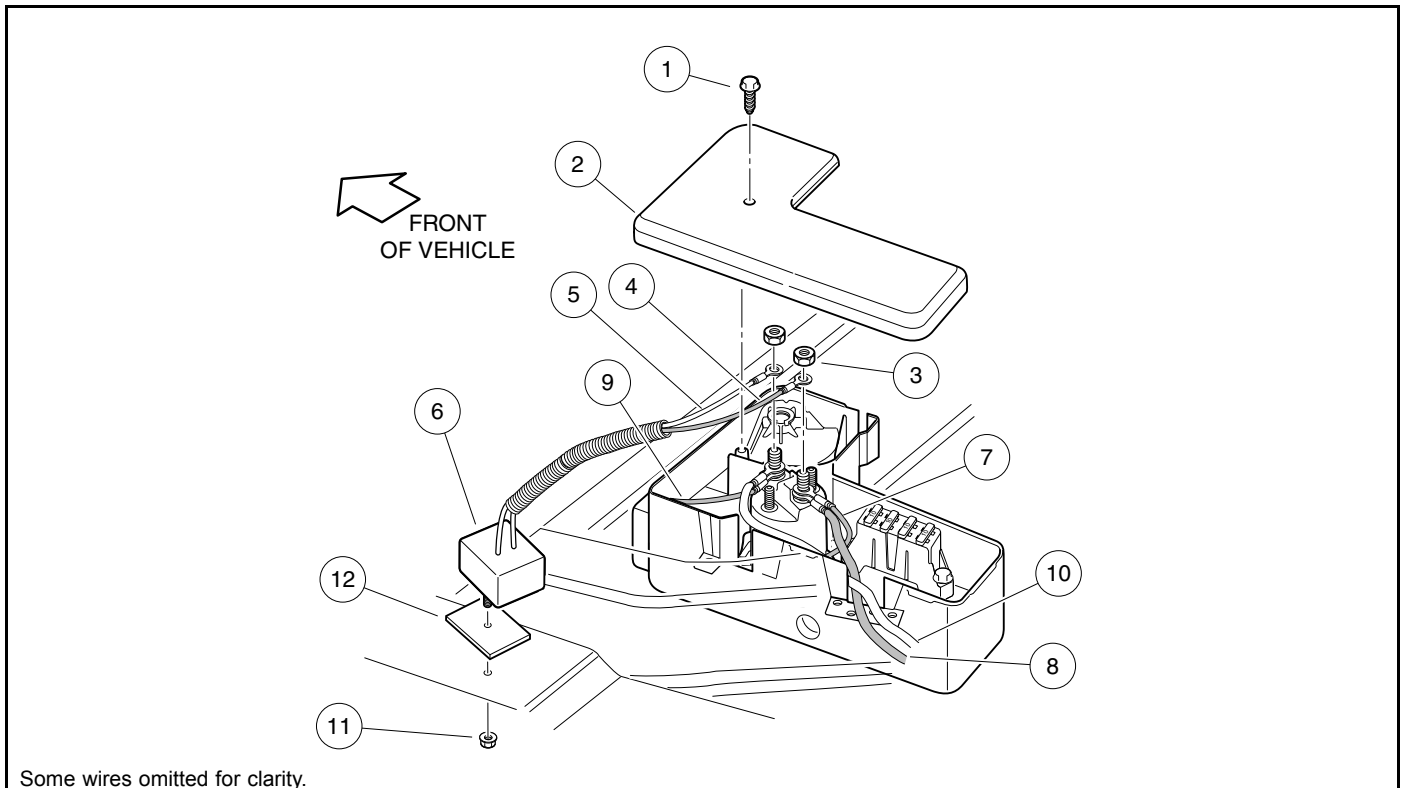

2978

Figure 21-2 Charging Diode

CHARGING DIODE INSTALLATION

1. Thoroughly clean and dry the area of the chassis where the new charging diode (6) is to be attached.
2. Peel the protective film from both sides of the new thermal pad (12) (Figure 21-2, Page 21-5). See following CAUTION.

CAUTION

- Be sure to remove and discard the protective film from both sides of the thermal pad before installing it. If not removed, the film will reduce the thermal heat transfer and therefore reduce the power handling capability of the diode, causing it to overheat and damage the electrical system.
3. Mount the charging diode (6) using the new thermal transfer pad (12) and mounting nut (11). Tighten nut (11) to 25 in·lb (2.8 N·m) (Figure 21-2, Page 21-5).
 4. Route and connect the red (4) and white (5) diode wires to the solenoid posts in the electrical component box. See following WARNING.

⚠ WARNING

- Incorrect wiring could result in severe injury or death.
 - Charging diode and solenoid connections must have correct polarity.
 - Keep all persons clear of engine belts when making final connections.
- 4.1. Connect the 10-gauge red wire (4) from the charging diode to the solenoid post with the fuse block and battery red wires (7 and 8). Tighten locknut (3) to 55 in·lb (6.2 N·m) (Figure 21-2, Page 21-5).

- 4.2. Connect the 10-gauge white wire (5) to the other large solenoid post, along with the red wire (9) from the voltage regulator and white wire (10) from the starter/generator. Tighten nut (3) to 55 in·lb (6.2 N·m).
5. Replace the electrical component box cover (2) and screw (1) and tighten the screw to 18 in·lb (2.0 N·m).
6. Connect battery and spark plug wire(s). **See Connecting the Battery-Gasoline Vehicles on page 1-5.**

⚠ DANGER

- See General Warnings on page 1-1.

⚠ WARNING

- See General Warnings on page 1-1.

GENERAL INFORMATION

See General Warnings on page 1-1.

This vehicle is powered by a Subaru EX40, high-compression, chain driven, overhead cam engine. The engine offers a heavy-duty construction featuring cast iron cylinder liner for longer life, dual ball bearing crankshaft support, low oil level sensor and heavy-duty air cleaner system, to name a few characteristics. **See following NOTE.**

NOTE: *Engine rotation is counterclockwise as viewed from the clutch side of the engine.*

This section contains information for removing and replacing the engine. For complete instruction on engine disassembly, repair, rebuilding, and reassembly, see your authorized dealer.

Test cylinder compression using a standard compression tester. Low compression would normally indicate a problem in the cylinder assembly such as defective rings, gaskets, etc. Compression should be:

At a normal cranking speed of 1050 to 1100 RPM, the compression should typically be approximately 167 psig (1151 kPa). This value could vary slightly depending on wear of components affecting compression.

See the Subaru EX40 Engine Repair and Rebuild Manual for complete teardown, rebuild and repair information.

BEFORE SERVICING

Carefully read the applicable information and instructions before beginning engine service. Diagrams, DANGER, WARNING, CAUTION and NOTE statements and detailed descriptions have been included wherever necessary. Anyone attempting engine service should have knowledge and experience in small engine service and repair.

ENGINE ROTATION

When turning the crankshaft by hand, always turn it counterclockwise as viewed from the clutch side of the engine.

TORQUE SPECIFICATIONS

ITEM	SIZE	TORQUE	
Flywheel retaining nut	M18	80 ft·lb (110 N·m)	
Crankcase cover to block bolts	M8	250 in·lb (28.3 N·m)	
Cylinder head bolts	M10	1st Step New head and bolts: 159 in·lb (18 N·m)	2nd Step New head and bolts: 336 in·lb (38 N·m)
		Used head and bolts: 159 in·lb (18 N·m)	Used head and bolts: 265 in·lb (30 N·m)
	M8	159 in·lb (18 N·m)	2 nd step not needed
Connecting rod bolts	M8	221 in·lb (25 N·m)	
Spark plug	13/16 in. (21 mm) plug socket	New: 120 in·lb (13.5 N·m)	
		Re-tightening: 216 in·lb (24.5 N·m)	
Exhaust flange nuts	M8	177 in·lb (20 N·m)	
Ignition coil	M6	71 in·lb (8 N·m)	
Oil sensor	M6	80 in·lb (9 N·m)	
Oil drain plug	M14	18 ft·lb (24.4 N·m)	
Fan housing screws	M6	90 in·lb (10 N·m)	
Fan cover screws	M6	25 in·lb (2.8 N·m)	
Bolts marked with "4" (when used with nuts)	M8	130 in·lb (15 N·m)	
	M6	50 in·lb (5.9 N·m)	
	M5	30 in·lb (3.4 N·m)	

ADJUSTMENTS AND SETTINGS

ITEM	VALUES
Spark plug gap	0.024 to 0.028 in. (0.6 to 0.7 mm)
Valve clearance – Intake & Exhaust (cold)	0.0047 to 0.0059 in. (0.12 to 0.15 mm)
Ignition coil air gap	0.012 to 0.020 in. (0.3 to 0.5 mm)
Compression pressure:	167 psig (1151 kPa) Allowable Lower Pressure: 120 psig (827 kPa)

ENGINE OIL – GASOLINE VEHICLE

Even though the low oil warning light on the dash should illuminate if oil level becomes low, engine oil level should be checked monthly. Vehicle should be on a level surface when checking oil. Do not overfill with oil.

Engine Oil Level Check

1. Remove the oil level dipstick from the oil filler tube, and wipe oil off dipstick (**Figure 22-1**). See following **CAUTION**.

CAUTION

- Do not remove dipstick while engine is running.

2. Check oil by fully inserting the dipstick into the oil filler tube and immediately removing it.
3. If the oil level is at or below the low level mark on the dipstick gauge, add oil until the level is between low and full levels (safe level).
4. Insert the dipstick into the oil filler tube. **See following NOTE.**

NOTE: Properly recycle or dispose of used oil in accordance with local, state, and federal regulations.

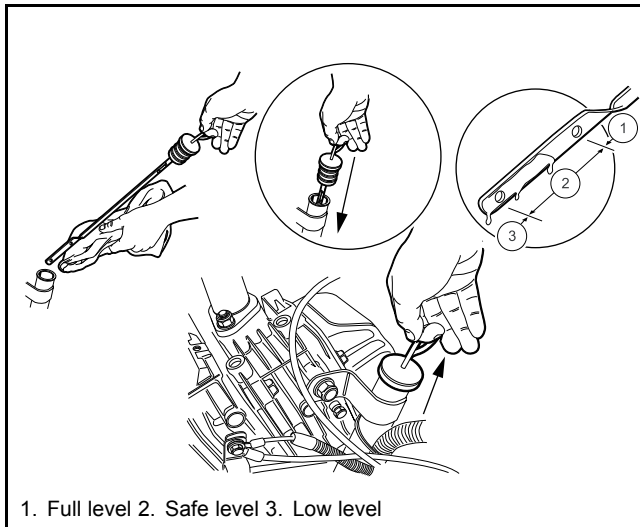

2662

Figure 22-1 Engine Oil Level Check

Engine Oil Change

Engine oil should be changed after the first 100 hours of operation. After that, it should be changed every 200 hours of operation or annually, whichever comes first.

1. Turn the key switch to the OFF position, then remove the key. Place the Forward/Reverse handle in the NEUTRAL position. Chock the front wheels.
2. Access the engine compartment and place the Maintenance/Operate switch in the MAINTENANCE position.
3. Disconnect battery and spark plug wire. **See Disconnecting the Battery-Gasoline Vehicles on page 1-5.**
4. Position a pan designed for oil changes under the drain plug (1) (**Figure 22-2**).

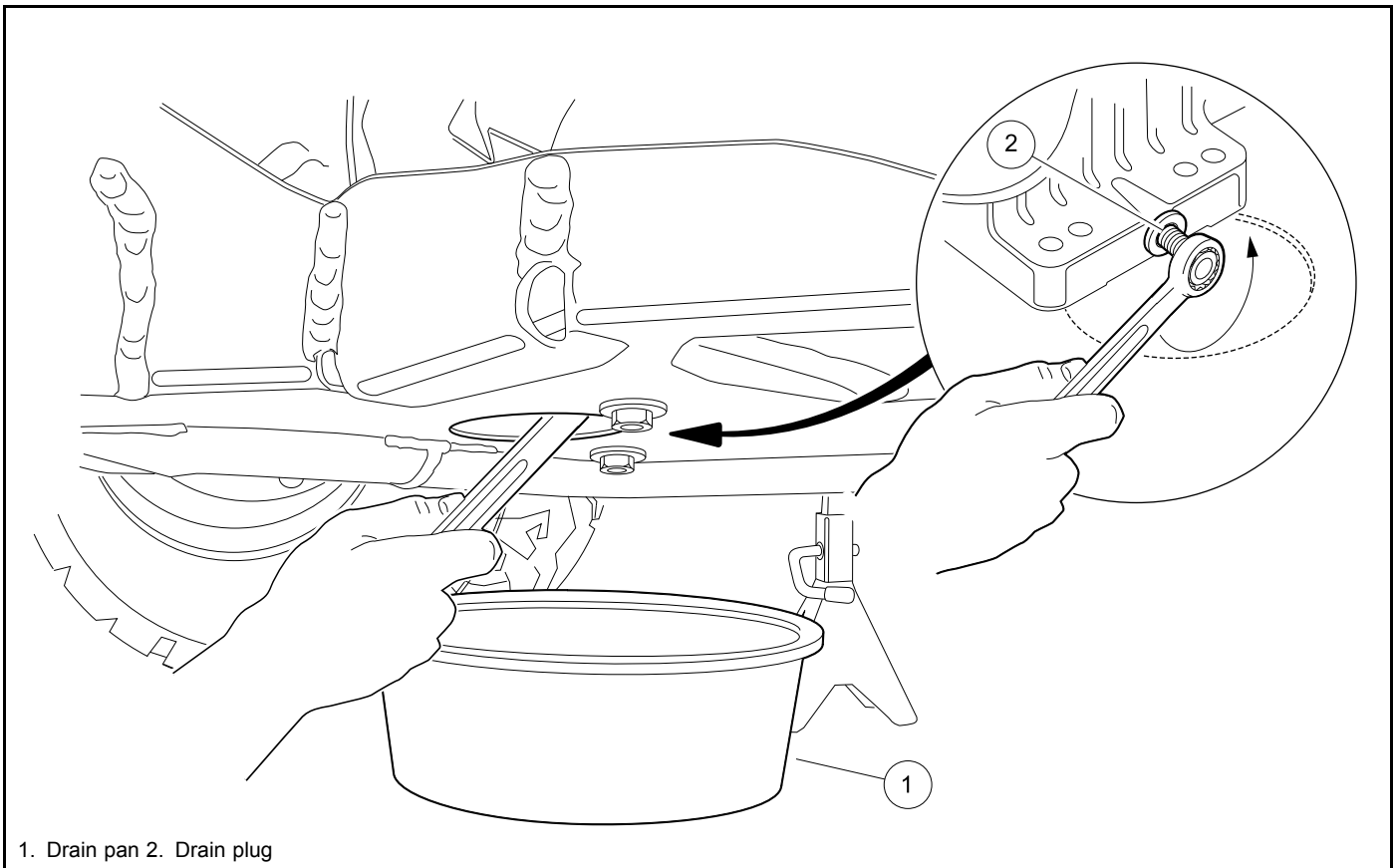

2667

Figure 22-2 Engine Oil Drain Plug and Pan

5. Use a 14 mm socket or wrench to remove the drain plug, turning it counterclockwise, and allow the engine oil to drain into the pan. **See following WARNING.**

▲ WARNING

- **Do not attempt to change engine oil when the engine is hot or even warm. Engine oil can cause skin burns.**
 - **Wear safety glasses or approved eye protection when servicing the vehicle. Wear rubber gloves when handling oil drain plug and oil drain pan.**
6. Clean the oil drain plug threads with solvent to remove oil and oil residue. Make sure that the compression washer remains on the drain plug.
 7. Use a 14 mm socket or wrench and replace the oil drain plug, turning it clockwise, and tighten to 18 ft·lb (24.4 N·m).
 8. Remove the dipstick and add engine oil into the dipstick port. Use a funnel or pour spout to direct the oil into the dipstick port. The engine requires 40.5 fl-oz (1.2 L) of oil per change. 10W-30 or 5W-30 grade SE or higher is recommended. Refer to oil viscosity guidelines for selection of oil grade (**Figure 22-3**). Replace the dipstick.

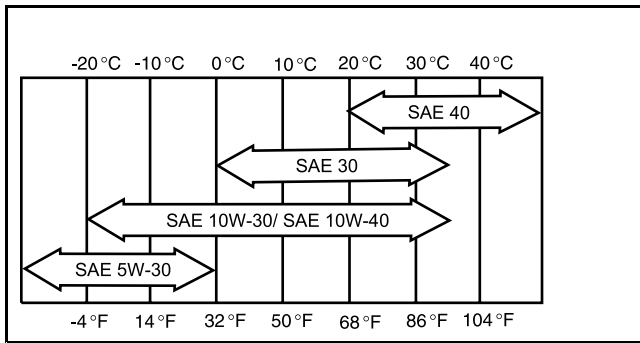

213

Figure 22-3 Oil Viscosity Chart

9. Connect battery and spark plug wire. **See Connecting the Battery-Gasoline Vehicles on page 1-5.**
10. With the Forward/Reverse handle in the NEUTRAL position and the Maintenance/Operate switch in the OPERATE position, start and run the engine for a few minutes. Observe the drain plug from under the vehicle and watch for oil leaks. If leaks appear, begin with step 1 and repeat the appropriate steps as needed to correct the problem.
11. Remove the dip stick and check the engine oil as a final step. Replace the dip stick.

SPARK PLUG

Spark plugs are selected to suit specific engine design and vehicle operating conditions. The spark plug (CC P/N 47539956001) is designed to give maximum life and efficient combustion of fuel. The spark gap should be set from 0.024 to 0.028 in. (0.6 to 0.7 mm).

Spark Plug Removal

⚠ CAUTION

- Before removal and disassembly, clean the engine.

Remove all dirt from plug base in the cylinder head before removing plug. Use a 13/16 in. (21 mm), deep well socket with ratchet or spark plug wrench to loosen the plug.

Spark Plug Cleaning, Inspection and Repair

Examine the plug (**Figure 22-4, Page 22-6**). The deposits on the plug base and electrode are an indication of the correct heat range and efficiency as well as a guide to the general condition of the engine, fuel and air mixture and ignition system. If all of the above conditions are proper, the spark plug should be a light brown color. There should be no bridging between the electrode and base. The electrode should not be eroded. Black color, excessive carbon, and/or a wet plug indicates that the fuel is too rich. White, burned or melted electrodes indicate the fuel is too lean or pre-igniting. Oily deposits on the plug electrode are an indication of worn rings, valve guides, cylinder wall, etc. Also examine the spark plug wire. Remove rubber boot and inspect internal spring for damage. Inspect spark plug wire for damage and be sure spring coil is securely attached to spark plug. **See following WARNING.**

⚠ WARNING

- Remove spark plug wire to avoid accidental start up of the engine when servicing vehicle. To avoid ignition of fuel and serious personal injury or death, never try to start the engine with plug removed from engine.

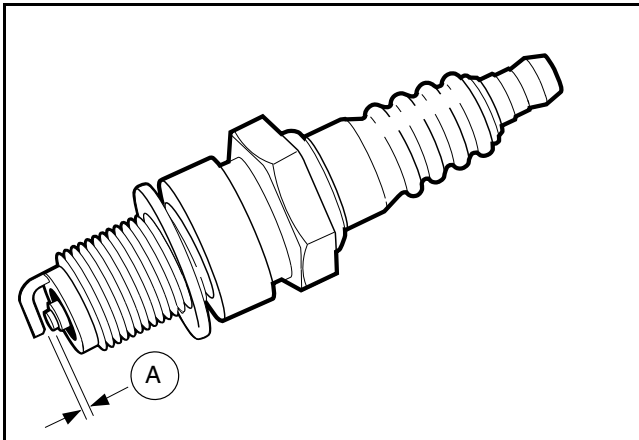

524

Figure 22-4 Spark Plug

Testing the Spark Plug

Check the sparking ability of a cleaned and properly gapped plug on a sparking comparator if possible. Spark should be blue and strong and able to jump a 5/16-in. (8 mm) gap.

Setting the Spark Gap

1. Pass a contact point file between the electrodes to produce flat, parallel surfaces to facilitate accurate gauging.
2. Use a wire type gauge. Bend the outside or ground electrode so only a slight drag on the gauge is felt when passing it between the electrode. Never make an adjustment by bending the center electrode. Set gap (A) from 0.024 to 0.028 in. (0.6 to 0.7 mm) (**Figure 22-4, Page 22-6**).

Spark Plug Installation

NOTE: Before installing the plug, check the condition of the threads in the cylinder head. Soften deposits in cylinder head threads with penetrating oil and clean the threads with a tap if necessary.

Use a high temperature, anti-seize lubricant on the threads of the spark plug to reduce friction when installing a new plug, and reduce "gauling" and thread seizing for future replacements.

Install the spark plug by threading it in until finger tight, then tighten the spark plug to the following torque:

- **New:** 120 in·lb (13.5 N·m).
- **Re-tightening:** 216 in·lb (24.5 N·m).

BREATHER

The function of the breather is to create a vacuum in the crankcase which prevents oil from being forced out of the engine through the piston rings, oil seals or gaskets. The breather has a reed valve which limits the direction of air flow caused by the piston moving up and down. Air can flow out of the crankcase, but the one-way reed valve blocks return flow and therefore maintains a vacuum in the crankcase.

Oil laden air in the crankcase passes through the reed valve and expands into the rocker chamber. In the rocker chamber most oil separates from the air and drains back to the crankcase. The air passes through a tube and vents to the intake manifold.

VALVE CLEARANCE CHECK AND ADJUSTMENT

NOTE: Check and adjust clearance when the engine is cold.

1. If equipped, remove air deflector from top of engine.
2. Remove rocker cover.
3. Turn the crankshaft until the piston is at top dead center of the compression stroke (**Figure 22-5, Page 22-7**).
4. Using a feeler gauge (1), measure the clearance between the adjuster screw (3) and the top of the valve stem (**Figure 22-6, Page 22-7**).
5. If necessary, loosen the lock nut (2) and turn the adjuster (3) up or down to adjust the clearance to 0.0047 in. (0.12 mm) for both intake and exhaust. Once clearance is correct, tighten the lock nut (2) to 52 in·lb (6 N·m).
6. After adjusting valve clearances, rotate the crankshaft several full revolutions and verify that the intake and exhaust valve clearance are still correct.

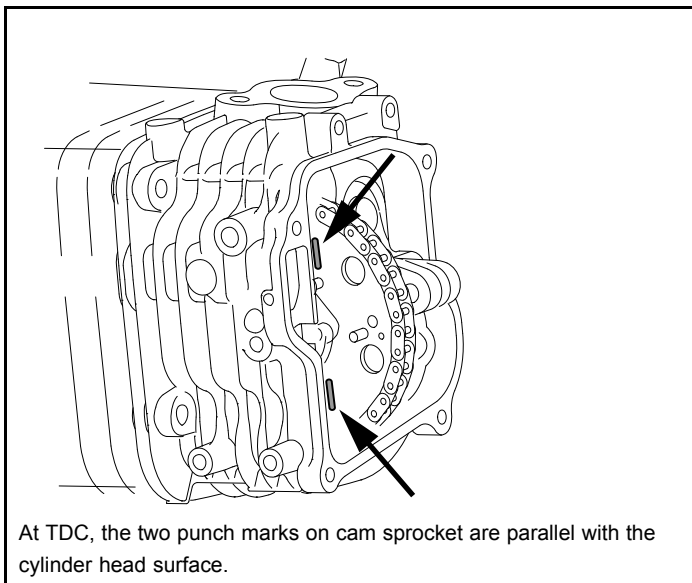

3034

Figure 22-5 Top Dead Center (TDC) – EX40 Engine

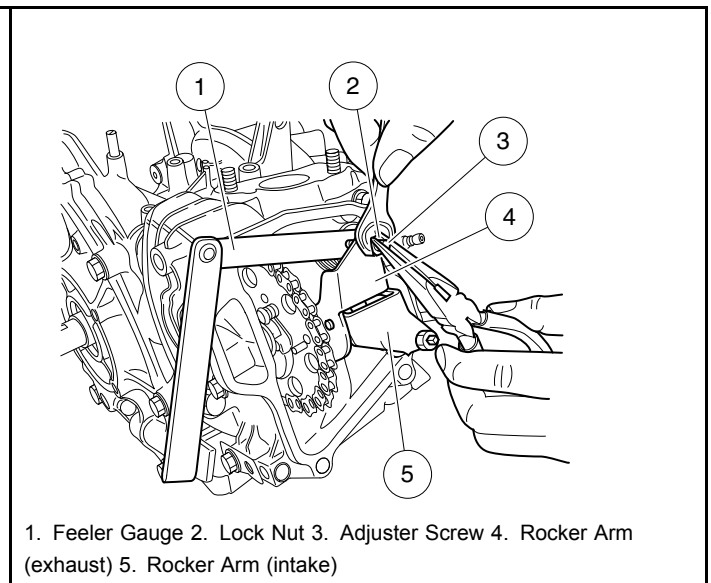

3035

Figure 22-6 Setting Valve Clearance – EX40 Engine

ENGINE REMOVAL

See General Warnings on page 1-1.

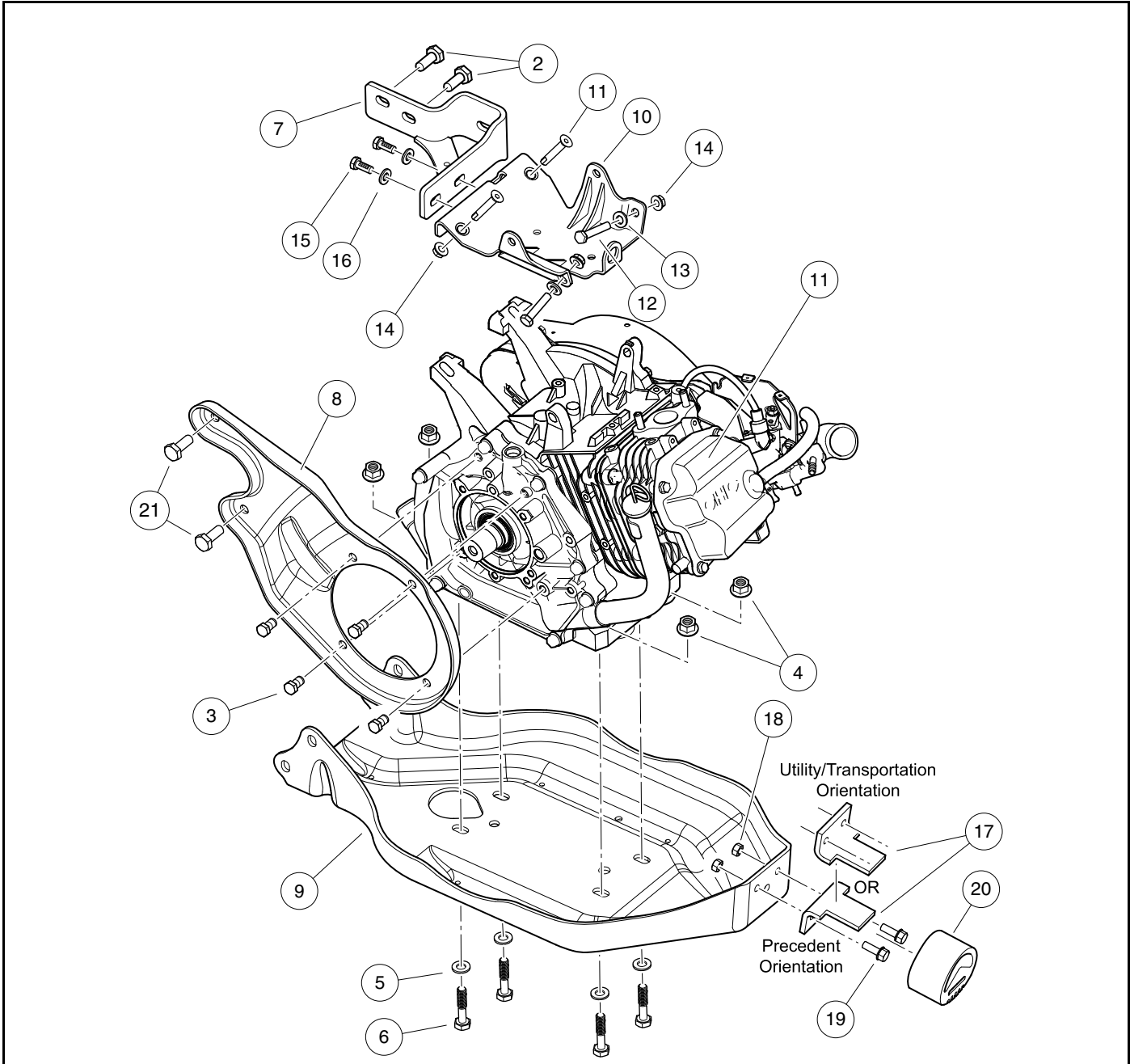

3036a

Figure 22-7 EX40 Engine and Mounting Brackets

CAUTION

- Before removal and disassembly, clean the engine.

1. Disconnect battery and spark plug wire(s). See **Disconnecting the Battery-Gasoline Vehicles** on page 1-5.

2. For some vehicles, the engine (1) can be removed by lifting it up and out of the chassis. For other vehicles, it is easier to remove the entire powertrain assembly first. If removing powertrain, **see Transaxle Removal on page 26-9**.
3. If equipped, remove air deflector from top of engine.
4. Disconnect governor cable and P-clamp, air intake hose, fuel line, wire harness connectors, ground cable, and accelerator cable P-clamp. **See Fuel System: Gasoline Vehicles, Section 23, Page 23-1**.
5. Remove starter/generator and belt. **See Starter/Generator Removal, Section 20, Page 20-1**.
6. Remove drive clutch. **See Drive Clutch Removal, Section 25, Page 25-5**.
7. Remove muffler. **See Muffler Removal, Section 24, Page 24-1**.
8. Remove engine mounting hardware (2, 3, 4, 5, and 6) from muffler bracket (7), clutch plate (8), and engine pan (9) (**Figure 22-7, Page 22-8**).
9. Lift engine (1) from engine pan (9). **See following NOTE**.

NOTE: The engine weighs approximately 54 lb (24.5 kg).

10. Remove crankcase oil drain plug and drain all oil from crankcase. Dispose of engine oil properly.
11. If replacing engine (1), remove starter/generator mounting weldment (10) and retain for installation on new engine. **See following NOTE**.

NOTE: If replacing engine and throttle body, the ECU must also be replaced. Throttle bodies and ECU's are matched pairs.

ENGINE INSTALLATION

See General Warnings on page 1-1.

1. If replacing engine (1), install starter/generator mounting weldment (10) on engine with screws (11), bolts (12), washers (13), and locknuts (14) (**Figure 22-7, Page 22-8**). Tighten locknuts (14) only finger-tight at this time.
2. Install oil drain plug and tighten to 18 ft·lb (24.4 N·m).
3. Place engine (1) onto engine pan (9) and secure with mounting hardware (4, 5, and 6). Leave flange nuts (4) loose at this time.
4. Install clutch plate (8) with bolts (3 and 21). Leave bolts loose at this time.
5. Install bolts (2) through muffler bracket (7) into transaxle but do not tighten.
6. Tighten hardware in the following order:
 - 6.1. Tighten bolts (3) to 27 ft·lb (36 N·m).
 - 6.2. Tighten bolts (21) to 50 ft·lb (68 N·m).
 - 6.3. Tighten bolts (2) to 50 ft·lb (68 N·m).
 - 6.4. Tighten flange nuts (4) to 33 ft·lb (40.6 N·m).
 - 6.5. Tighten locknuts (14) and bolts (15) to 17 ft·lb (23 N·m).
7. Install drive clutch. **See Drive Clutch Installation, Section 25, Page 25-11**.
8. Install muffler. **See Muffler Installation, Section 24, Page 24-1**.
9. Install starter/generator and belt. **See Starter/Generator Installation, Section 20, Page 20-12**.
10. If necessary, install powertrain. **See Transaxle Installation, Section 26, Page 26-13**.
11. Connect air intake hose, fuel line, wire harness connectors, ground cable and governor cable. **See Fuel System: Gasoline Vehicles, Section 23, Page 23-1**.
12. If equipped, install air deflector on top of engine.
13. Secure accelerator cable and governor cable P-clamps to engine. Tighten P-clamp bolts to 36 in·lb (4.0 N·m).

14. Check all hardware for proper torque/tightness.
15. Fill engine to proper level with correct type of oil. **See Engine Oil – Gasoline Vehicle, Section 22, Page 22-2.**

⚠ CAUTION

- **Do not overfill with oil.**

16. Connect battery and spark plug wire(s). **See Connecting the Battery-Gasoline Vehicles on page 1-5.**
17. Adjust the engine RPM setting. **See Engine RPM Adjustment on page 23-13.**
18. Test-drive vehicle to ensure all systems are functional and correctly adjusted.

FLYWHEEL

See General Warnings on page 1-1.

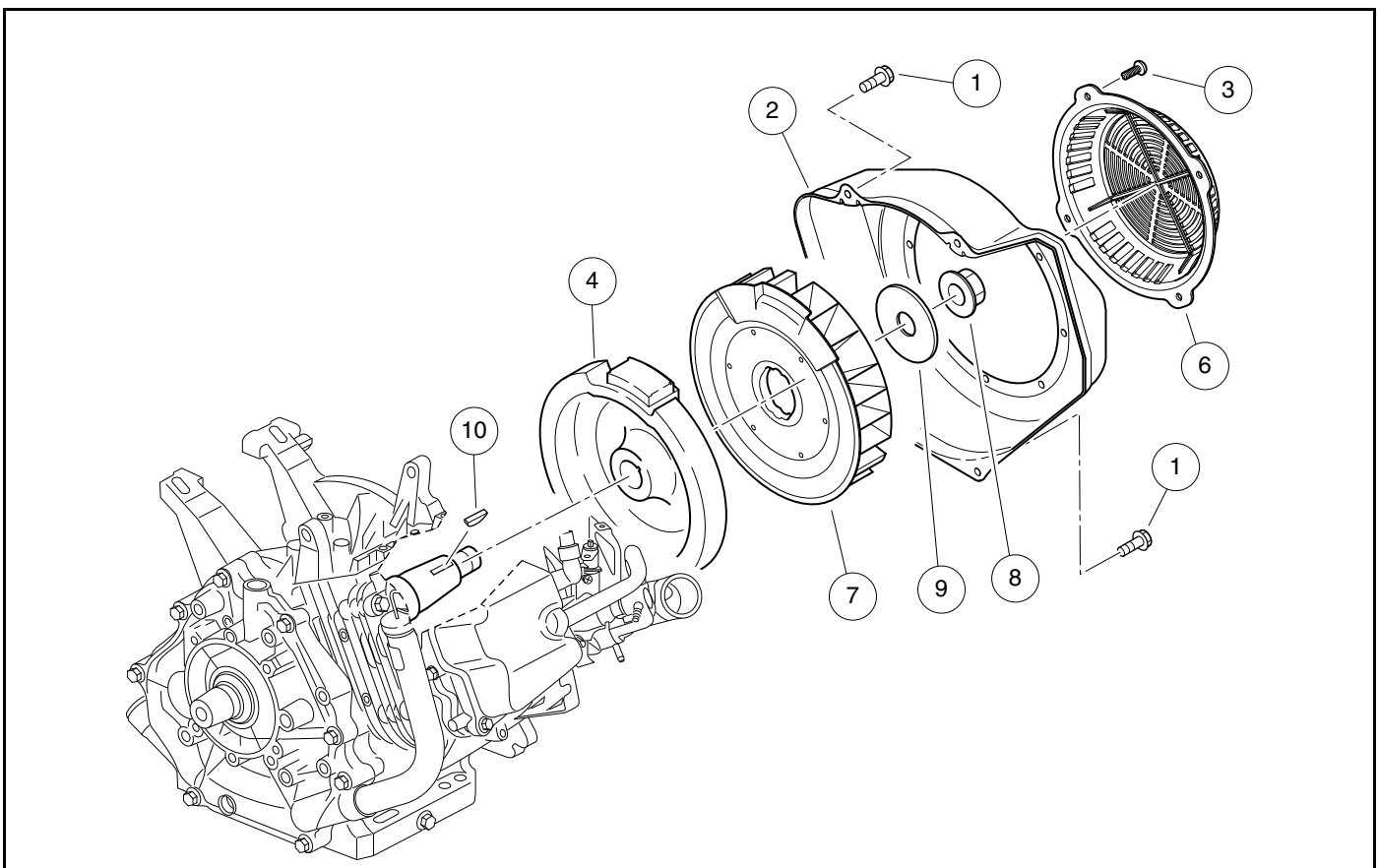

3037

Figure 22-8 Flywheel, Fan and Fan Housing – EX40

FLYWHEEL REMOVAL

1. Remove screws (1) and fan housing (2) (**Figure 22-8, Page 22-10**).

2. Hold flywheel (4) only, not fan (7), with strap wrench (5) and use a 24 mm socket to remove flywheel nut (8) and flat washer (9) by turning it counterclockwise (**Figure 22-9, Page 22-11**). **See following CAUTION.**

⚠ CAUTION

- The flywheel nut has right-hand threads. Turn it clockwise to tighten, or counterclockwise to loosen.
 - Do not damage the fan blades with the strap wrench. Do not place screwdriver or pry bar in the fan blades.
3. Temporarily install flywheel nut (8) onto end of crankshaft to protect threads and to prevent flywheel (4) from falling off while being pulled.
 4. Detach flywheel (4) from crankshaft with a large, two-jaw puller.
 5. Remove flywheel nut (8) and flywheel (4) from crankshaft.
 6. Remove woodruff key (10) from groove in crankshaft.

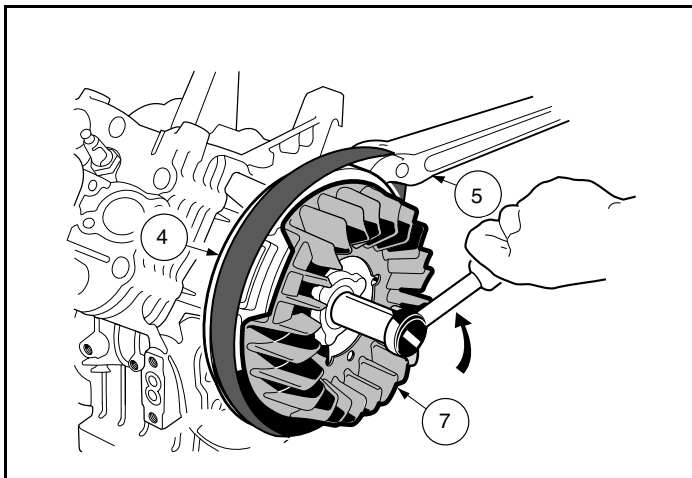

532

Figure 22-9 Flywheel Nut Removal

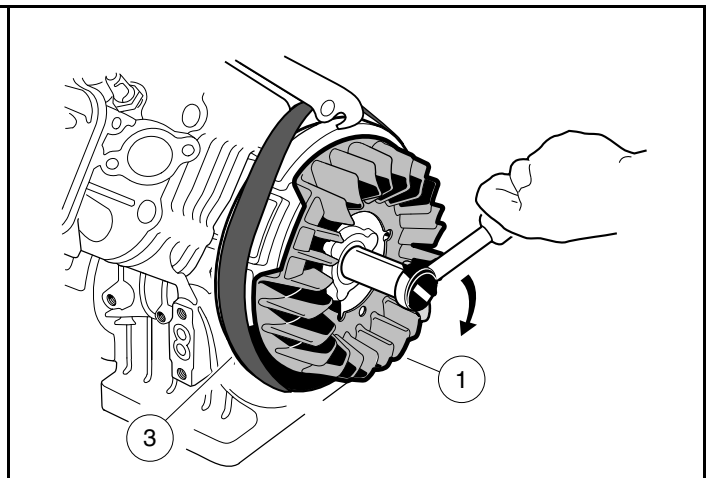

533

Figure 22-10 Fan and Flywheel Installation

FLYWHEEL INSTALLATION

1. Wipe off any oil on tapered portions of crankshaft and flywheel (4) (**Figure 22-8, Page 22-10**).
2. Insert woodruff key (10) into keyway of crankshaft. Then align groove in flywheel (4) to woodruff key (10) and push flywheel onto crankshaft until it seats. Install and fan (7), flat washer (9), and nut (8) finger-tight.
3. Use a strap wrench (3) to keep flywheel and fan assembly (1) from turning while tightening flywheel nut to 80 ft·lb (110 N·m) (**Figure 22-10, Page 22-11**). **See following CAUTION.**

⚠ CAUTION

- The flywheel nut has right-hand threads. Turn it clockwise to tighten, or counterclockwise to loosen.
 - Be careful not to damage the fan blades. Use a strap wrench to hold flywheel. Do not place screwdriver or pry bar between fan blades.
4. Install fan housing (2) and tighten screws (1) to 90 in·lb (10 N·m) (**Figure 22-8, Page 22-10**).

OIL LEVEL SENSOR

TESTING THE OIL LEVEL SENSOR

See Oil Level Sensor on page 18-37.

OIL LEVEL SENSOR REMOVAL

1. Drain oil from engine. **See Engine Oil – Gasoline Vehicle, Section 22, Page 22-2.**
2. Remove flywheel. **See Flywheel Removal on page 22-10.**
3. Remove bolt (1) securing oil sensor wire clamp (2) to engine.
4. Disconnect oil level sensor wire (3) from wire harness (**Figure 22-11, Page 22-12**).
5. Remove two bolts (4) securing oil sensor (5) in engine.
6. Pull oil level sensor (5) out of engine.

OIL LEVEL SENSOR INSTALLATION

1. Lubricate oil level sensor o-ring with oil and carefully insert sensor (5) into engine until fully seated.
2. Secure sensor (5) to engine with two bolts (4) and tighten to 80 in·lb (9 N·m) (**Figure 22-11, Page 22-12**).
3. Connect oil level sensor wire (3) to wire harness.
4. Secure oil sensor wire (3) with clamp (2) and bolt (1). Tighten bolt to 80 in·lb (9 N·m).
5. Install flywheel and fan shroud. **See Ignition Coil Removal on page 22-13.**
6. Fill engine to proper level with correct type of oil. **See Engine Oil – Gasoline Vehicle, Section 22, Page 22-2.**

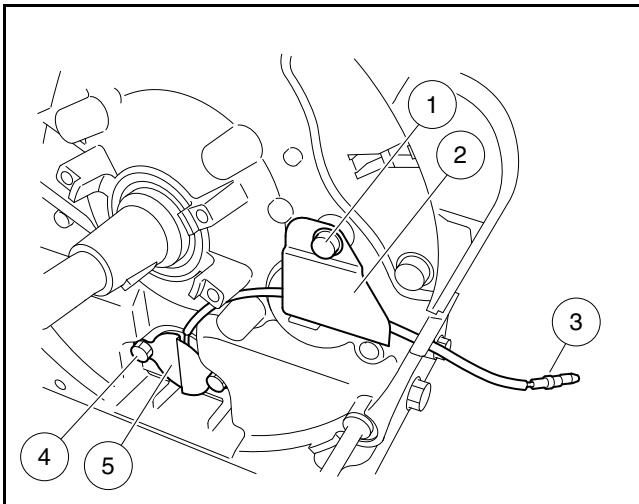

3038

Figure 22-11 Oil Level Sensor – EX40

IGNITION COIL

See General Warnings on page 1-1.

TESTING THE IGNITION COIL

See Test Procedure 15 – Ignition Spark on page 18-34 and Test Procedure 16 – Ignition Coil on page 18-35.

IGNITION COIL REMOVAL

1. Remove screws (1) and fan housing (2) (**Figure 22-8, Page 22-10**).
2. Disconnect ignition coil primary lead wire (12) from spade terminal (13) on ignition coil (11) (**Figure 22-12, Page 22-13**).
3. Remove two bolts (10) and pull ignition coil (11) from engine.

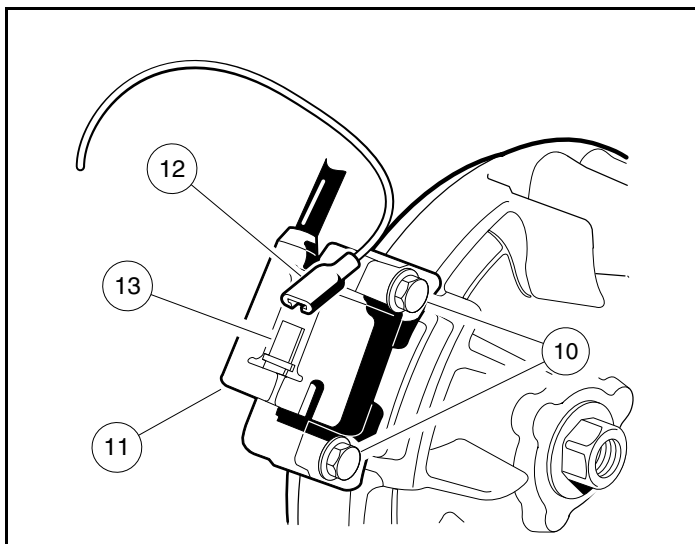

510

Figure 22-12 Ignition Coil

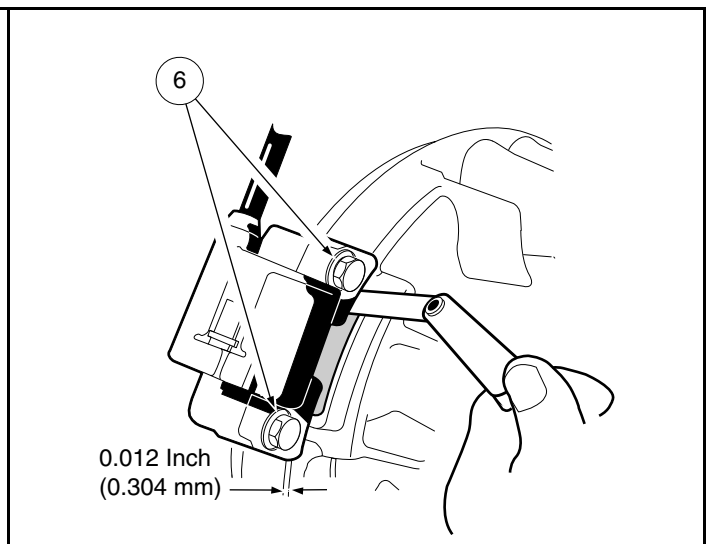

512

Figure 22-13 Adjust Ignition Coil Air Gap

IGNITION COIL INSTALLATION

1. Position ignition coil (11) onto engine and tighten two mounting bolts (10) finger-tight at this time (**Figure 22-12, Page 22-13**).
2. Rotate flywheel until its magnet is positioned directly under ignition coil (11). Use a bronze feeler gauge to set air gap between ignition coil and flywheel magnet from 0.012 to 0.020 in. (0.3 to 0.5 mm) (**Figure 22-13, Page 22-13**).
3. Tighten ignition coil bolts (6) to 71 in·lb (8 N·m).
4. Connect ignition coil primary lead wire (12) to terminal (13) on coil (**Figure 22-12, Page 22-13**).

SNUBBER

See General Warnings on page 1-1.

NOTE: The snubber is installed on the gasoline vehicle only.

SNUBBER REMOVAL

1. Support the powertrain with a floor jack under the engine pan (1) so that the snubber (2) is raised slightly and does not rest on the vehicle frame (**Figure 22-14, Page 22-14**).
2. Remove the two bolts (3) and two lock nuts (4) securing the snubber bracket (5) to the engine pan (1).
3. Slide snubber (2) and bracket (5) assembly toward battery to remove it from vehicle.
4. Slide snubber (2) off bracket (5).

SNUBBER INSTALLATION

1. Slide snubber (2) onto bracket (5) (**Figure 22-14, Page 22-14**).
2. Install bracket and snubber assembly onto engine pan (1).
3. Tighten lock nuts (4) from 20 to 25 ft·lb (27.1 to 33.9 N·m).

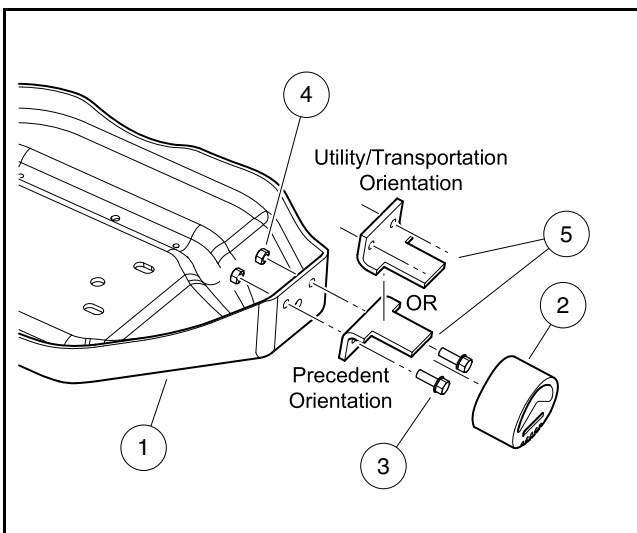

3039

Figure 22-14 Snubber

⚠ DANGER

- See General Warnings on page 1-1.

⚠ WARNING

- See General Warnings on page 1-1.
- Fuel may be under pressure. Use extreme caution when disconnecting fuel line to prevent the spray of fuel onto hot engine. See Relieving Fuel Pressure on page 23-2.
- To prevent damage to the ECU, never mix the black and gray connectors that attach to it. The black connector is tethered to the ECU mounting plate to help prevent accidentally installing it in the gray port.

GENERAL INFORMATION

The engine is equipped with a throttle body/fuel injector assembly that is controlled by an ECU and requires no adjustment. The ECU monitors engine conditions through inputs from a Manifold Absolute Pressure (MAP) sensor, engine block temperature sensor and ignition timing.

EFI SYSTEM FEATURES/SPECIFICATIONS

NOTE: This manual covers ECU software version F6i33051.

- The ECU and throttle body/fuel injector assembly are matched pairs and are not available separately
- Fuel pump and low oil warning light operates for a few seconds when key switch is turned to the ON position; it stops if no engine RPM is detected by the ECU
- The ECU blinks fault codes through the Low Oil Warning Lamp
- In-tank fuel pump
- Return-less system
- High fuel pressure system (36 to 38 psig (250 to 260 kPa))
- Controls fuel pump, fuel injector, and oil lamp
- Automatic altitude compensation
- Flow: 16 L per hour minimum @ 12-volts/36 psig (250 kPa)
- Current draw: 2-amps maximum
- Throttle Body Bore: 31 mm diameter
- Open-loop system (i.e. oxygen sensor not used)
- Separate EFI wire harness
- Fail-safe function

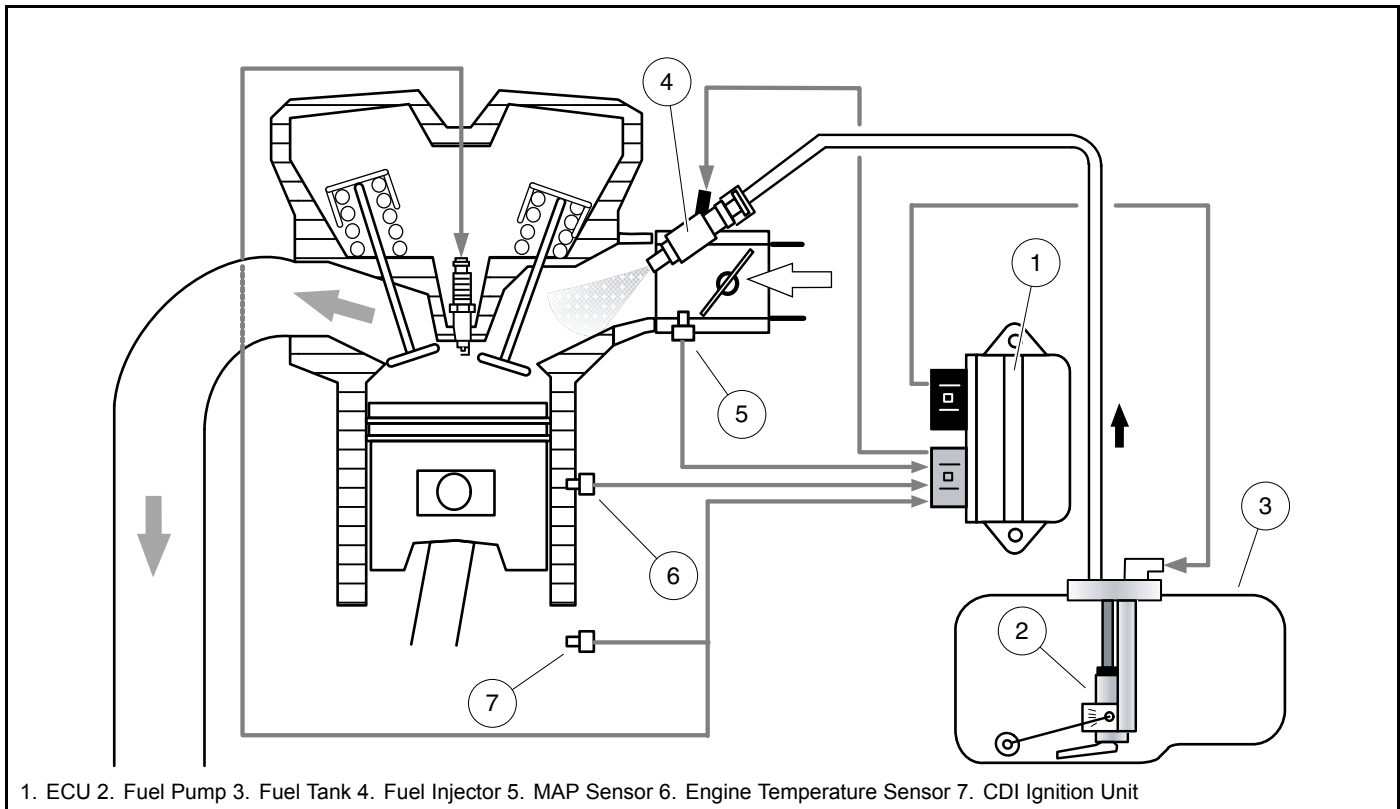

3040

Figure 23-1 EFI System Components

RELIEVING FUEL PRESSURE

In the event that servicing the EFI fuel system necessitates removal of the fuel delivery hose, extreme caution must be exercised. The fuel system is under high pressure even with the engine not running. Disconnecting any part of the fuel delivery system, without first depressurizing the system, will result in a sudden release of pressurized gasoline at the connection. To prevent possible serious injury or death, fuel pressure must be relieved before disconnecting or removing the pump, hose and throttle body.

Either of these suggested procedures **MUST** be followed before attempting ANY service work on the EFI fuel system. Following these will relieve any pressure in the fuel hose prior to opening the fuel system.

TO RELIEVE FUEL PRESSURE

- Shut off engine, disconnect battery,
See Disconnecting the Battery-Gasoline Vehicles on page 1-5.

Wait 15 minutes or more to allow pressure to dissipate.

– or –

- Unplug fuel pump module at fuel tank and crank engine for 5 seconds to start reducing fuel pressure. Pause and repeat an additional 5 seconds to allow pressure to dissipate.

NOTE: To absorb any residual fuel that may be present in the fuel hose, place a rag or towel around the hose at the end being disconnected.

THROTTLE BODY

See General Warnings on page 1-1.

Before suspecting the throttle body as the cause of poor engine performance, make sure the fuel and ignition systems are in proper operating condition. Check the following items:

- Spark plug and gap condition. **See Spark Plug on page 22-5.**
- Air filter element. **See Air Filter on page 23-15.**
- Air intake system (for restriction of air flow). **See Air Intake System on page 23-14.**
- Exhaust system (for restrictions). **See Exhaust System: Gasoline Vehicles on page 24-1.**
- Fuel pump. **See Fuel Pump Module on page 23-18.**
- Fuel line. **See Fuel Line on page 23-16.**
- Fuel pickup screen or filter. **See Fuel Filter on page 23-23.**

THROTTLE BODY REMOVAL

See General Warnings on page 1-1.

1. Turn the key switch to the OFF position and remove the key, place the Forward/Reverse handle in the NEUTRAL position, and chock the wheels.
2. Disconnect battery. **See Disconnecting the Battery-Gasoline Vehicles on page 1-5.**
3. If equipped, remove air deflector from top of engine.
4. If necessary, remove fuel tank to increase access to the throttle body (1). **See Fuel Tank Removal, Section 23, Page 23-21.**
5. Clean the throttle body (1) and surrounding area (**Figure 23-2, Page 23-4**).
6. Disconnect breather hose (2) from air intake adapter (3).
7. Disconnect governor cable from bracket (4).
8. Disconnect fuel injector and MAP sensor.
9. Remove spring clamps securing fuel line (6) and vent hose (5) to throttle body (1) and disconnect vent hose (5).
10. Disconnect fuel line (6) and drain into an appropriate container. **See following WARNING.** Temporarily plug fuel line to prevent fuel leakage.

⚠ WARNING

- **Fuel may be under pressure. Use extreme caution when disconnecting fuel line to prevent the spray of fuel onto hot engine. See Relieving Fuel Pressure on page 23-2.**
 - **Carefully drain any fuel into an approved container. Add drained fuel back into fuel tank or dispose of properly.**
11. Loosen air intake hose clamp and disconnect air intake hose.
 12. Remove two flange nuts (7) and slide air intake adapter (3), bracket (4), gaskets (8), insulator (9), and throttle body (1) off threaded studs.

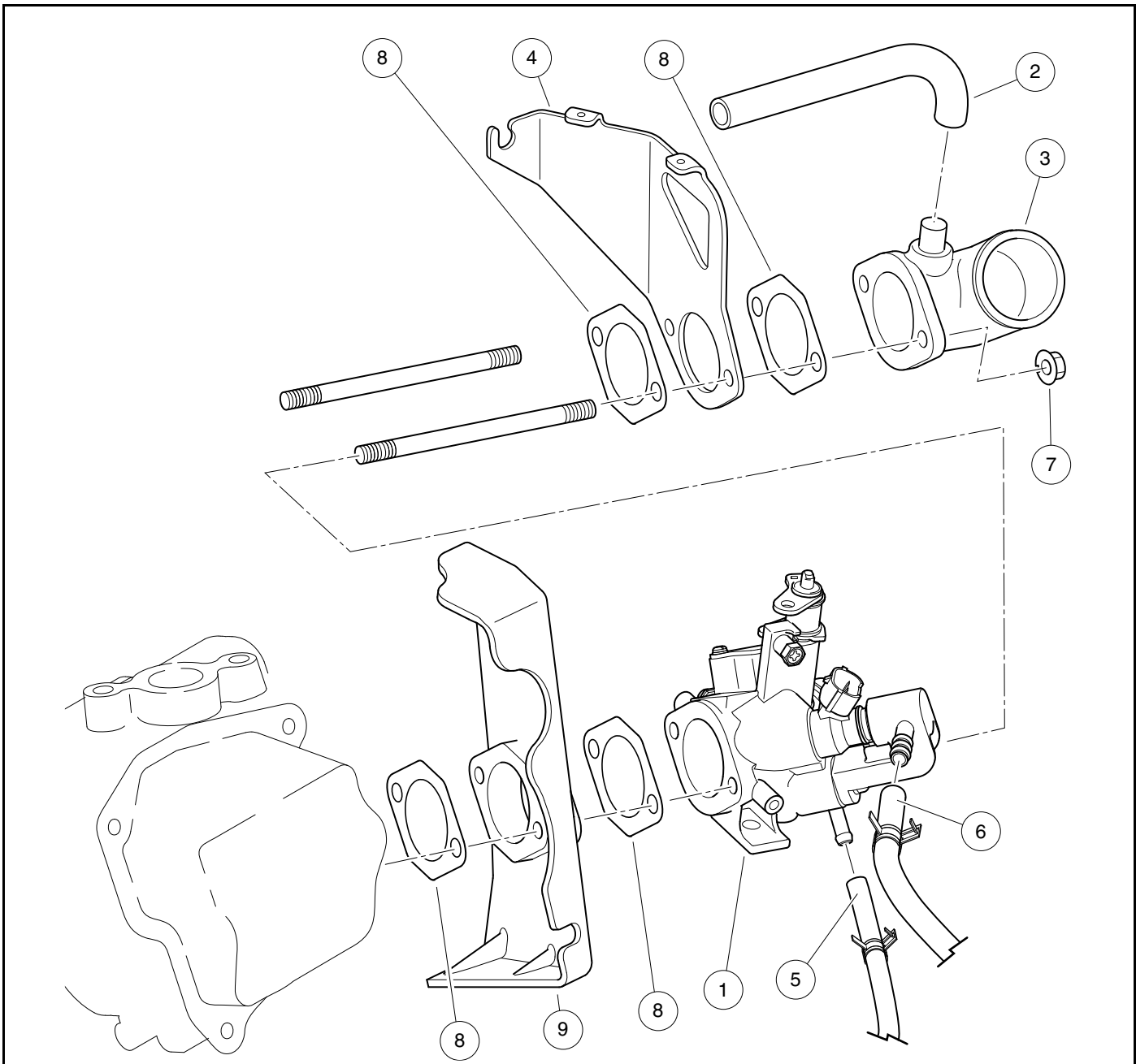

3041

Figure 23-2 Throttle Body – Exploded View

THROTTLE BODY INSTALLATION

See General Warnings on page 1-1.

1. Install throttle body (1) and its related components onto threaded studs in order as shown (**Figure 23-2, Page 23-4**).
2. Install two flange nuts (7) and tighten to 53 to 71 in·lb (6 to 8 N·m).
3. Connect fuel line (6) and vent hose (5). Secure with spring clamps.
4. Connect fuel injector and MAP sensor.

5. Connect governor cable to bracket (4).
6. Connect breather hose (2) to air intake adapter (3).
7. Connect air intake hose and secure with hose clamp.
8. If removed, install fuel tank. **See Fuel Tank Installation, Section 23, Page 23-22.**
9. If equipped, install air deflector on top of engine.
10. Clean spilled and remove any drained gasoline from the area.
11. Connect battery. **See Connecting the Battery-Gasoline Vehicles on page 1-5.**
12. Place the Forward/Reverse handle in the NEUTRAL position, chock the wheels, and the neutral lockout switch in the MAINTENANCE position (**Figure 26-1, Page 26-1**).
13. Turn the key switch to the ON position and check for fuel leaks. Repeat as necessary to build fuel pressure. Any leaks found must be fixed.

DANGER

- **Repair all fuel leaks before returning the vehicle to service.**

14. If no leaks are found, place the neutral lockout switch in the OPERATE position (**Figure 26-1, Page 26-1**).
15. Test drive vehicle to ensure proper operation.

ENGINE CONTROL LINKAGES

See General Warnings on page 1-1.

▲ DANGER

- To ensure the vehicle does not run over you while you disconnect or adjust the accelerator push rod, do the following:
 - Turn key switch OFF and remove key, place Forward/Reverse handle in the NEUTRAL position, and chock the wheels prior to servicing the vehicle.
 - Disconnect battery cables, negative (-) cable first.
 - Disconnect the spark plug wire from the spark plug.
 - See Disconnecting the Battery-Gasoline Vehicles on page 1-5.

GENERAL INFORMATION

For proper vehicle operation, it is important the accelerator pedal, governor linkage, and throttle adjustments are done correctly and in the proper sequence. **See following CAUTION.**

▲ CAUTION

- Improper adjustment can result in poor vehicle performance and/or damage to the engine components.

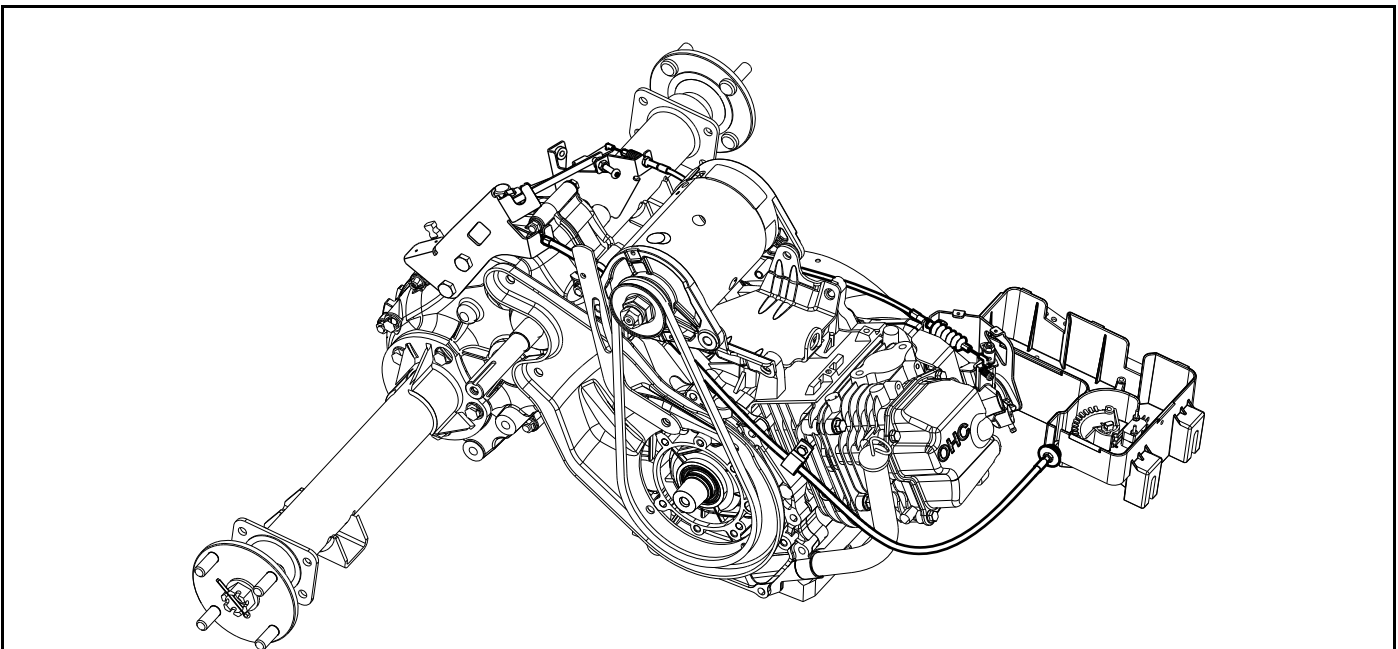

3042

Figure 23-3 Engine Control Linkages – EFI vehicles

GROUND SPEED

NOTE: If possible, the manufacturer recommends measuring ground speed when setting engine RPM.

This vehicle should reach the forward ground speed specified in **Section 2 – Vehicle Specifications**. See **How to Measure Ground Speed** on page 23-13.

ACCELERATOR ROD

Accelerator Rod Removal

1. Raise the front of the vehicle. Place chocks at the rear wheels and lift the front of the vehicle with a chain hoist or floor jack. Place jack stands under the round frame cross tube to support the vehicle. **See preceding DANGER. See also WARNING “Lift only one end of the vehicle...” in General Warnings on page 1-1.**
2. Remove the accelerator rod by disconnecting the ball joint (1) from the ball stud (2) on the accelerator pedal (Figure 23-4, Page 23-7) and from the bell crank at the electrical box (Figure 23-5, Page 23-7).

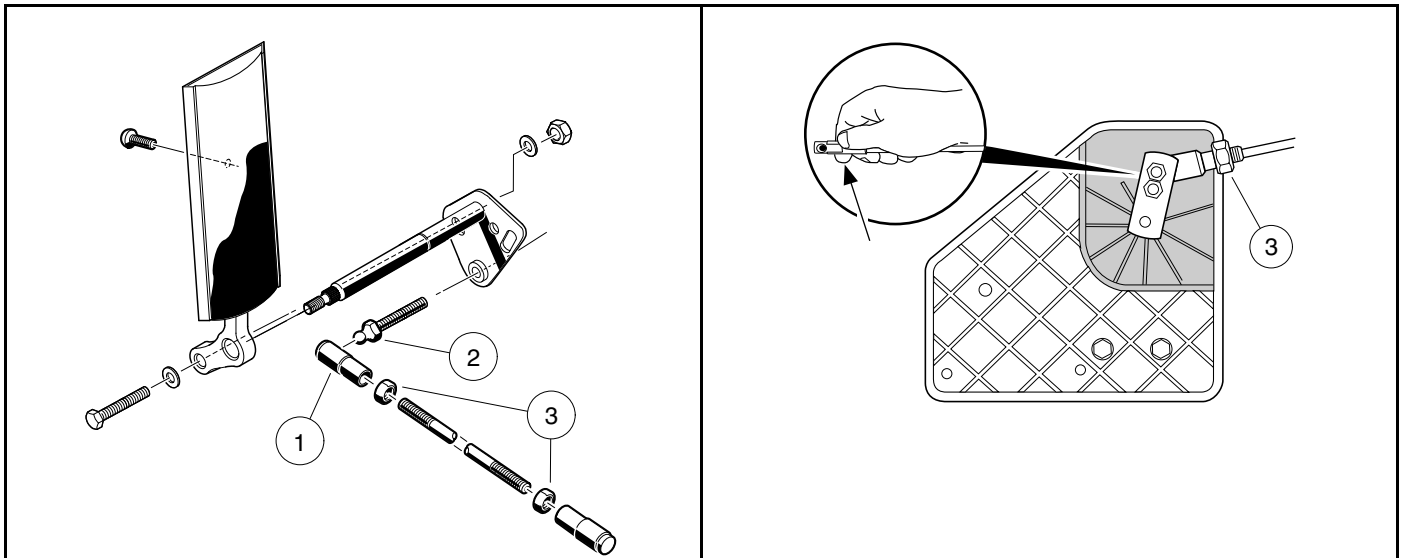

539

Figure 23-4 Accelerator Rod

1345

Figure 23-5 Accelerator Rod – Pull Spring Release to Attach (Bottom View)

Accelerator Rod Installation and Adjustment

1. Before installing the accelerator rod, adjust accelerator pedal position. **See Pedal Group Adjustment – Gasoline Vehicles in the Accelerator and Brake Pedal Group Section.**
2. Install the ball joint (1) on the ball stud (2) at the accelerator pedal (Figure 23-4, Page 23-7).
3. Access the engine compartment.
4. Remove the electrical component box screw and cover (Figure 23-6, Page 23-8).
5. Adjust length of accelerator rod. With the ball joint jam nuts (3) loose (Figure 23-4, Page 23-7), adjust the length of the rod to obtain an accelerator cable cam position of 7° as shown (Figure 23-6, Page 23-8). **See following CAUTION.**

CAUTION

- Be sure that approximately an equal number of threads are exposed at each end of the accelerator rod.
6. Install the accelerator rod on the bell crank ball joint on the electrical component box (Figure 23-5, Page 23-7). **See following CAUTION.**

⚠ CAUTION

- Inspect the limit switches inside the electrical component box. If a limit switch lever is bent, replace the switch.

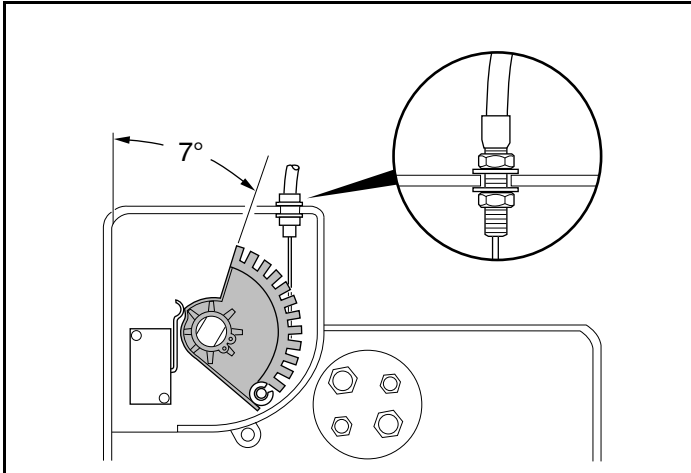

3113

Figure 23-6 Accelerator Cable Cam Position – 7° (Top View)

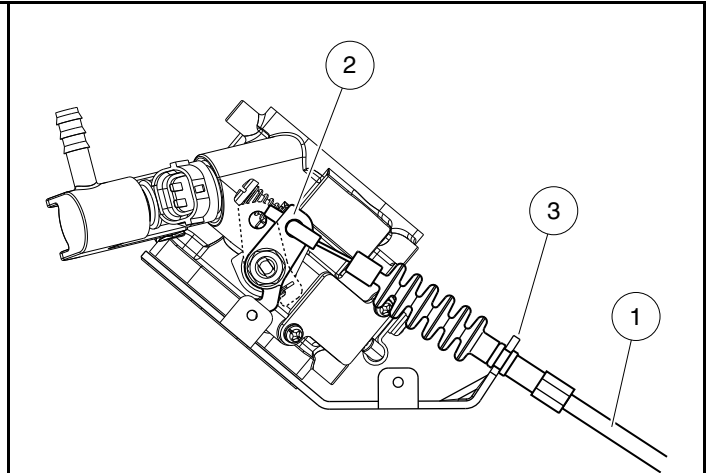

3043

Figure 23-7 Governor Cable At Throttle Body

- Before tightening the jam nuts (3), set the park brake to the first latch and pawl position and check for proper activation of switches.
- While pressing the accelerator pedal, the following events should occur in exactly the order shown:

NOTE: Always perform a visual check to ensure the starter motor begins rotating the engine prior to the throttle body lever moving.

EVENT	APPROXIMATE PEDAL TRAVEL
Park brake release	0° to 4°
Solenoid activation and engine start	4° to 15°
Throttle body actuation	15° and greater

- While holding the accelerator ball joint with pliers, tighten the jam nuts against the ball joints, accelerator ball joint first, at each end of the accelerator rod.
- Check rod adjustment for proper switch activation.
- After the pedal group and accelerator rod are properly adjusted, adjust the engine RPM setting. **See Engine RPM Adjustment on page 23-13.**
- Install the electrical component box cover and tighten retaining screw to 18 in·lb (2.0 N·m).
- Connect battery and spark plug wire(s). **See Connecting the Battery-Gasoline Vehicles on page 1-5.**

GOVERNOR CABLE

Governor Cable Removal

1. Turn the key switch to the OFF position and remove the key, place the Forward/Reverse handle in the NEUTRAL position, and chock the wheels.
2. Disconnect battery and spark plug wire(s). **See Disconnecting the Battery-Gasoline Vehicles on page 1-5.**
3. At engine:
 - 3.1. If equipped, remove air deflector from top of engine.
 - 3.2. Disconnect "Z" fitting of governor cable (1) from throttle lever (2) (**Figure 23-7, Page 23-8**).
 - 3.3. Unsnap governor cable (1) from throttle body bracket (3).
4. At transaxle:
 - 4.1. Disconnect "Z" fitting of governor cable (1) from governor arm (4) (**Figure 23-8, Page 23-10**).
 - 4.2. Loosen jam nuts at governor bracket (5) and remove cable (1) from vehicle.

Governor Cable Installation and Adjustment

1. At engine:
 - 1.1. Snap governor cable (1) into throttle body bracket (3) (**Figure 23-7, Page 23-8**).
 - 1.2. Connect "Z" fitting of governor cable (1) to throttle lever (2).
 - 1.3. If equipped, install air deflector on top of engine.
2. At transaxle:
 - 2.1. Slide bellows off threaded end of cable housing, separate jam nuts and place threaded end into governor bracket (5) (**Figure 23-8, Page 23-10**).
 - 2.2. Finger-tighten jam nuts.
 - 2.3. Push bellows back onto threaded end of cable housing.
 - 2.4. Connect "Z" fitting of governor cable (1) to governor arm (4).
3. Rotate governor arm (4) counterclockwise until it stops and hold in this position (**Figure 23-9, Page 23-10**).
4. Adjust jam nuts until throttle lever (2) is at "wide open throttle" (WOT) (**Figure 23-7, Page 23-8**). Then, tighten the jam nuts to 36 in·lb (4.0 N·m).
5. Release governor arm (4) and loosen jam nut (6) on throttle stop screw (7) (**Figure 23-9, Page 23-10**).
6. Adjust gap between governor arm (4) and throttle stop screw (7) to 0.055 in. (± 0.039) (1.4 mm (± 1)) as shown.
7. Tighten stop screw jam nut (6) to 36 in·lb (4.0 N·m).
8. Check engine RPM adjustment. **See Engine RPM Adjustment on page 23-13.**

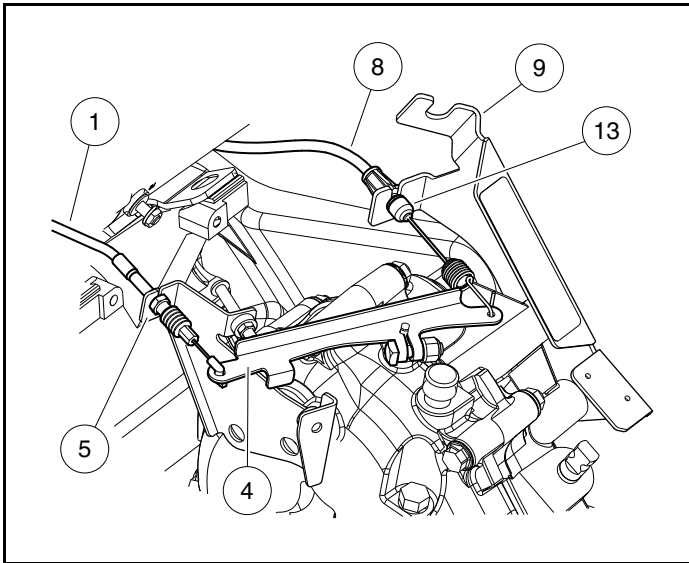

3110

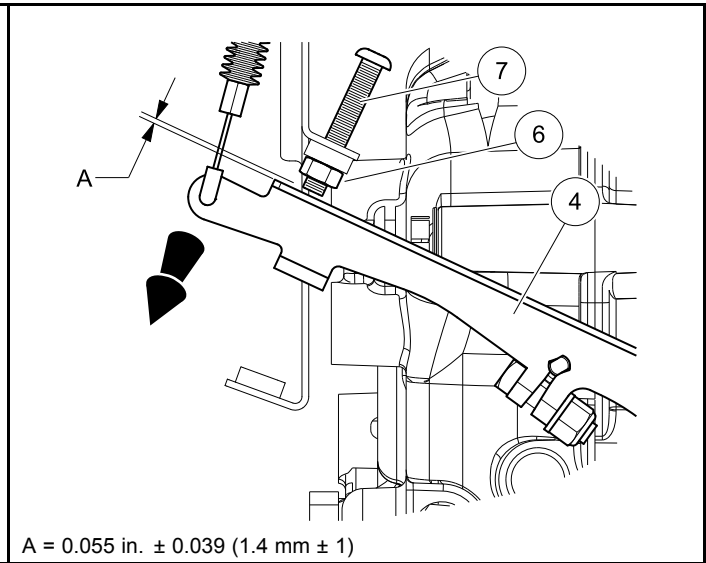
Figure 23-8 Governor and Accelerator Cables At Governor ArmA = 0.055 in. \pm 0.039 (1.4 mm \pm 1)

3111

Figure 23-9 Throttle Stop Screw Gap

ACCELERATOR CABLE

Accelerator Cable Removal

1. Turn the key switch to the OFF position and remove the key, place the Forward/Reverse handle in the NEUTRAL position, and chock the wheels.
2. Disconnect battery and spark plug wire(s). **See Disconnecting the Battery-Gasoline Vehicles on page 1-5.**
3. At transaxle:
 - 3.1. Unhook spring fitting of accelerator cable (8) from governor arm (4) (**Figure 23-8, Page 23-10**).
 - 3.2. Unsnap accelerator cable (8) from FNR/accelerator cable bracket (9).
4. At electrical component box:
 - 4.1. Remove electrical component box cover and loosen jam nuts (10) on side of electrical component box (**Figure 23-10, Page 23-11**).
 - 4.2. Disconnect barrel fitting (11) of accelerator cable (8) from cam (12) in electrical component box and remove accelerator cable (8) from vehicle.

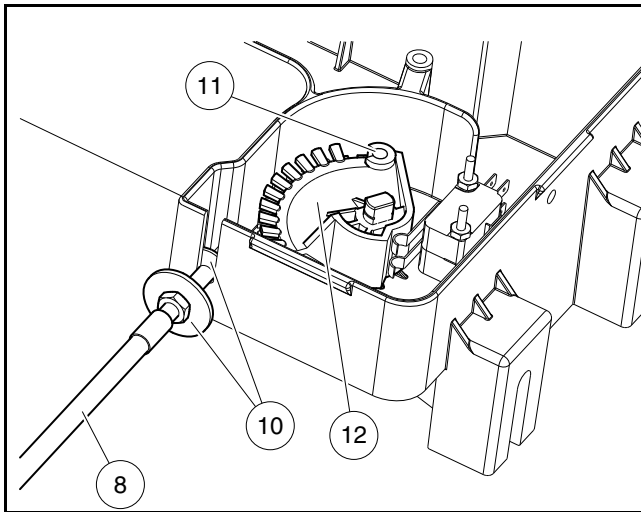

3046

Figure 23-10 Accelerator Cable At Electrical Component Box

Accelerator Cable Installation

1. At transaxle:
 - 1.1. Hook spring fitting of accelerator cable (8) to governor arm (4) (**Figure 23-8, Page 23-10**).
 - 1.2. Snap accelerator cable (8) into FNR/accelerator cable bracket (9).
 - 1.3. Push dust shield (13) onto end of cable housing.
2. At electrical component box:
 - 2.1. Insert barrel fitting (11) of accelerator cable (8) into cam (12) in electrical component box (**Figure 23-10, Page 23-11**).
 - 2.2. Separate jam nuts (10) on cable and place threaded end into slot of electrical component box. Tighten jam nuts (10) finger-tight.
 - 2.3. Before tightening the cable jam nuts (10), make sure the engine RPM adjustment is correct. **See Engine RPM Adjustment on page 23-13.**
 - 2.4. Install electrical component box cover and tighten screw to 18 in·lb (2.0 N·m).
3. Connect battery and spark plug wire(s). **See Connecting the Battery-Gasoline Vehicles on page 1-5.**

CLOSED THROTTLE OR IDLE ADJUSTMENT – PEDAL-START VEHICLES

When the accelerator pedal is released, the engine will stop. Therefore, it is not possible to measure or set idling speed under normal vehicle operating conditions. Set throttle valve as follows:

1. Loosen the throttle body idle screw so that it is not touching the throttle lever (**Figure 23-11, Page 23-12**).
2. Slowly tighten the idle screw until it lightly touches the throttle lever, then tighten it an additional 1 whole turn (360 degrees).

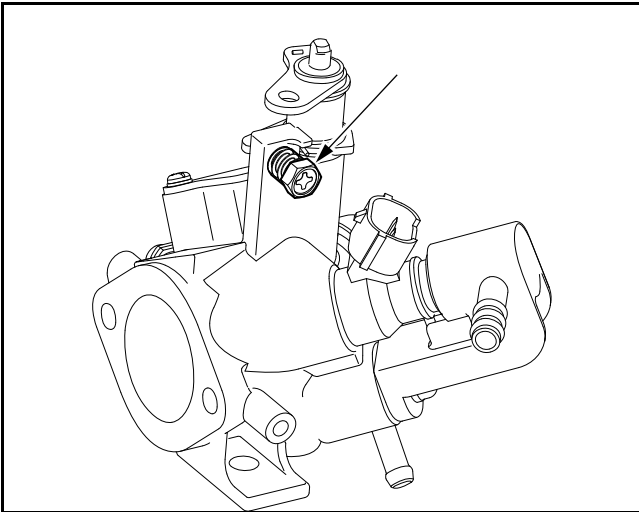

3047

Figure 23-11 Idle Screw

CLOSED THROTTLE OR IDLE ADJUSTMENT – KEY-START VEHICLES

Adjust the idle screw until idle RPM is 1200 (± 25) (**Figure 23-11, Page 23-12**).

HOW TO MEASURE GROUND SPEED

Best Method

An easy way to check ground speed is by using a GPS device or smartphone application (app). If these are not available, use the alternate method below.

Alternate Method (Calculated)

Ground speed is easily determined by a known distance travelled, divided by the amount of time it took to travel that known distance ($Rate = Distance/Time$).

1. Establish a known distance to travel (example: 100 ft. (30.5 m) in a safe location using cones or other type of marker.
2. Drive vehicle and bring to maximum speed before reaching the first cone.
3. Using a stopwatch, record the amount of time it takes to travel from the first cone to the second cone at maximum speed.
4. With distance and time determined, calculate ground speed:
 - 4.1. **Rate in seconds:** Divide distance (100 ft (30.5 m)) by time (5 seconds) = 20 ft/sec (6.1 m/sec).
 - 4.2. **Convert seconds to hour:** Multiply 20 ft/sec (6.1 m/sec) by 3600 (the number of seconds in an hour) = 72000 ft/hour (21960 m/hour)
 - 4.3. **Convert to MPH:** Divide 72000 ft/hour by 5280 (number of ft in 1 mile) = 13.64 miles/hour
Convert to KPH: Move the decimal point over three places; 21960 m/hour = 21.96 km/hour

ENGINE RPM ADJUSTMENT

DANGER

- **Do not operate gasoline vehicle in an enclosed area without proper ventilation. The engine produces carbon monoxide, which is an odorless, deadly poison.**

1. If governor is adjusted, proceed to step 2; otherwise, adjust governor. **See Governor Cable Installation and Adjustment on page 23-9.**
2. Connect battery and spark plug wire(s). **See Connecting the Battery-Gasoline Vehicles on page 1-5.**
3. Measure vehicle ground speed. **See How to Measure Ground Speed on page 23-13.**
4. Compare measured ground speed with forward ground speed specified in **Section 2 – Vehicle Specifications.**
5. If adjustment is necessary, use the following procedures:
 - 5.1. To **reduce** RPM, loosen the accelerator cable jam nut on the outside of the electrical component box and tighten the jam nut on the inside of the box until specified ground speed is reached (**Figure 23-10, Page 23-11**). **See Section 2 – Vehicle Specifications.**
 - 5.2. To **increase** RPM, loosen the jam nut inside the electrical component box and tighten the jam nut outside the box until specified ground speed is reached.
 - 5.3. Be sure both jam nuts are locked against the electrical component box and check ground speed again. If ground speed needs to be adjusted, repeat previous step. **See following NOTE.**

NOTE: *If more adjustment is required than the cable housing will allow, make sure the spring fitting on the other end of the accelerator cable is properly installed. Excessive drive belt and clutch wear can also prevent proper ground speed adjustment. Check them for excessive wear. **Section 25 — Clutches: Gasoline Vehicles***

AIR INTAKE SYSTEM

See General Warnings on page 1-1.

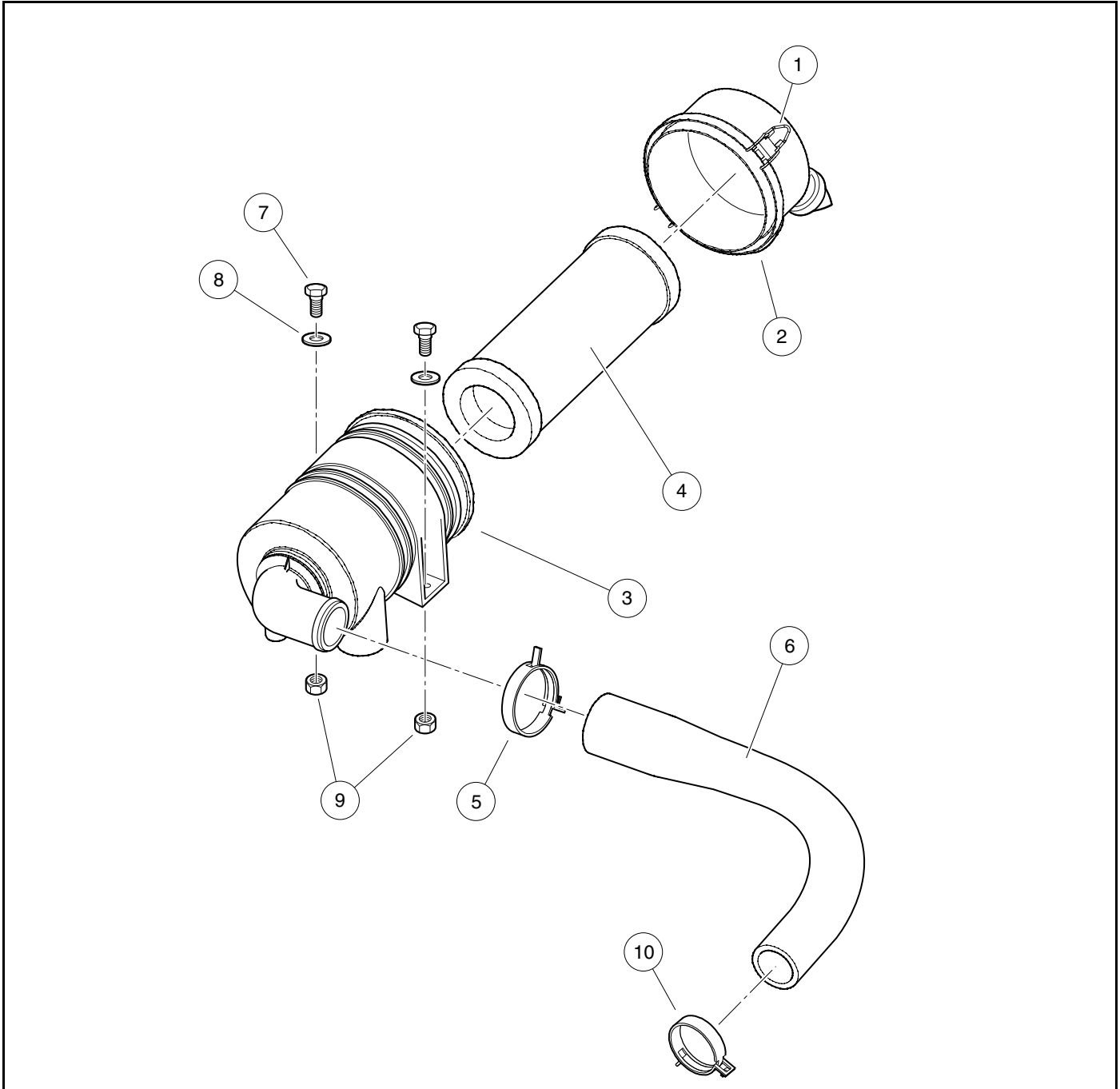

3048

Figure 23-12 Air Intake System – CA 500/550/700/TRANSPORTER/Cafe Express

AIR FILTER

The air filter should be inspected periodically and replaced when necessary. Filter changes should not exceed the recommended interval. **See Periodic Service Schedules, Section 10, Page 10-4.** More frequent service may be required in extremely dirty operating environments. In the event of a loss of power, sluggish acceleration, or a roughly running engine, service the air filter immediately.

Air Filter Replacement

1. Release both wire latches (1) (**Figure 23-12, Page 23-14**).
2. Pull cap (2) away from air cleaner (3).
3. Remove air filter (4). **See following NOTE.**

NOTE: *The filter is specifically designed for this engine. It fits into the canister only one way. Use only direct replacement part.*

4. Using a clean cloth, wipe away any dust or dirt from inside the air cleaner (3).
5. Push the new filter (4) onto the nozzle inside the air cleaner (3).
6. Position and place cap (2) onto air cleaner (3) so the "TOP" mark is at the 12 o'clock position.
7. Fasten wire latches (1). Make sure latches are securely engage. **See following CAUTION.**

⚠ CAUTION

- Engine damage will occur if the air cleaner cap is not properly secured.
- If air cleaner is extremely dirty, remove air cleaner from vehicle and clean thoroughly.
- Use only Club Car replacement air filters. The use of other air filters could result in engine damage and void the warranty.

AIR CLEANER REMOVAL

1. Turn key switch to the OFF position and remove key, place Forward/Reverse handle in the NEUTRAL position, and chock the wheels.
2. Disconnect battery and spark plug wire(s). **See Disconnecting the Battery-Gasoline Vehicles on page 1-5.**
3. Remove clamp (5) and disconnect air intake hose (6) from air cleaner (3) (**Figure 23-12, Page 23-14**).
4. Remove hardware (7, 8, and 9) securing air cleaner (3) to vehicle.

AIR CLEANER INSTALLATION

1. Place air cleaner (3) into vehicle and secure with hardware (7, 8, and 9) (**Figure 23-12, Page 23-14**). Tighten locknuts (9) to 85 in·lb (9.5 N·m).
2. Connect air intake hose (6) to air cleaner (3) and secure with clamp (5).
3. Connect battery and spark plug wire(s). **See Connecting the Battery-Gasoline Vehicles on page 1-5.**

FUEL LINE

See General Warnings on page 1-1.

NOTE: This EFI gasoline vehicle is equipped with SAEJ30R9 fuel hose rated for high-pressure systems. Always replace the fuel line on this vehicle with approved Club Car replacement part. Do not attempt to repair, patch or splice the fuel line.

The fuel line must be properly routed from the fuel tank to the throttle body. A small, spring steel band clamp is used on the fuel line connection at the throttle body and must be tight. A plastic, dual-locking connector is used at the fuel tank. **See following WARNING.**

⚠ WARNING

- **Make sure fuel line is the correct length and properly routed. Failure to heed this warning could result in damage to fuel line and fire.**
- **Fuel may be under pressure. Use extreme caution when disconnecting fuel line to prevent the spray of fuel onto hot engine. See Relieving Fuel Pressure on page 23-2.**

FUEL LINE REMOVAL

1. Turn the key switch to the OFF position and remove the key, place the Forward/Reverse handle in the NEUTRAL position, and chock the wheels.
2. Disconnect battery. **See Disconnecting the Battery-Gasoline Vehicles on page 1-5.**
3. Clean the top of the fuel tank and fuel pump module.
4. At engine:
 - 4.1. Remove spring clamp securing fuel line to throttle body.
 - 4.2. Disconnect fuel line and drain into an appropriate container. **See following WARNING.**

⚠ WARNING

- **Fuel may be under pressure. Use extreme caution when disconnecting fuel line to prevent the spray of fuel onto hot engine. See Relieving Fuel Pressure on page 23-2.**
 - **Carefully drain any fuel into an approved container. Add drained fuel back into fuel tank or dispose of properly.**
5. At fuel tank:
 - 5.1. Disengage clip as shown (**Figure 23-13, Page 23-17**).
 - 5.2. Push in tab to unlock connector and pull fuel line from nipple on fuel pump module and remove line from vehicle.

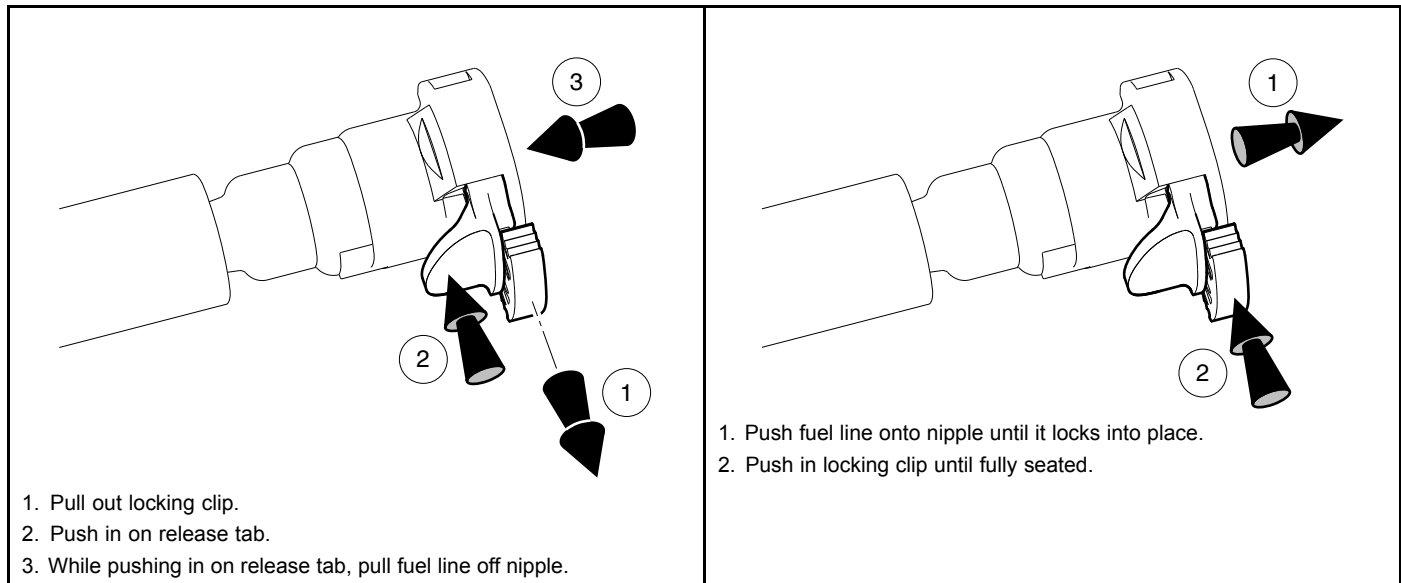

3050

Figure 23-13 Fuel Line Connector – To Disconnect

3051

Figure 23-14 Fuel Line Connector – To Connect

FUEL LINE INSTALLATION

1. At fuel tank:
 - 1.1. Clean the nipple on top of fuel pump module.
 - 1.2. Push fuel line fully onto nipple until it locks in place (**Figure 23-14, Page 23-17**).
 - 1.3. Engage locking clip by pushing in until fully seated and completely prevents the line from being pulled off nipple.
2. At engine:
 - 2.1. Connect fuel line to throttle body and secure with spring clamp. **See following DANGER.**

⚠ DANGER

- Ensure line is connected properly to avoid a leak that can cause a fire.

3. Clean spilled and remove any drained gasoline from the area.
4. Connect battery. **See Connecting the Battery-Gasoline Vehicles on page 1-5.**
5. Place the Forward/Reverse handle in the NEUTRAL position, chock the wheels, and the neutral lockout switch in the MAINTENANCE position (**Figure 26-1, Page 26-1**).
6. Turn the key switch to the ON position and check for fuel leaks. Repeat as necessary to build fuel pressure. Any leaks found must be fixed.

⚠ DANGER

- Repair all fuel leaks before returning the vehicle to service.

7. If no leaks are found, place the neutral lockout switch in the OPERATE position (**Figure 26-1, Page 26-1**).

FUEL PUMP MODULE

See General Warnings on page 1-1.

GENERAL INFORMATION

NOTE: The fuel pump and fuel level sending unit themselves are not replaceable. If necessary, the fuel pump module must be replaced as an assembly.

The fuel pump module can be disassembled to replace the fuel filter.

The EFI gasoline vehicle is equipped with an electric fuel pump. The fuel pump is protected by a filter and pickup screen.

FUEL PUMP MODULE REMOVAL

1. Turn the key switch to the OFF position and remove the key, place the Forward/Reverse handle in the NEUTRAL position, and chock the wheels.
2. Disconnect battery. **See Disconnecting the Battery-Gasoline Vehicles on page 1-5.**
3. Clean the top of the fuel tank and fuel pump module (1) (**Figure 23-15, Page 23-20**).
4. With a marker pen, make a mark across the top of the module (1) and onto the tank to note orientation before removal.
5. Disconnect wire harness plug (2).
6. Disconnect the fuel line (3) and drain into an appropriate container. **See Fuel Line Removal on page 23-16. See following WARNING.**

⚠ WARNING

- Fuel may be under pressure. Use extreme caution when disconnecting fuel line to prevent the spray of fuel onto hot engine. **See Relieving Fuel Pressure on page 23-2.**
 - Carefully drain any fuel remaining in the hose or pump module into an approved container. Add drained fuel back into fuel tank or dispose of properly.
7. Loosen fuel tank retaining strap (4) to allow tank to move and provide access to all of the fuel pump module hardware (5).
 8. Remove hardware (5) securing hold down ring (6) and ground wire (7) to fuel tank.
 9. Lift fuel pump module (1) out of fuel tank and drain into an appropriate container. Discard fuel module o-ring (8). **See preceding WARNING and following NOTE.**

NOTE: If equipped with a fuel level sending unit, carefully maneuver module so as to avoid damaging the float arm mechanism.

FUEL PUMP MODULE INSTALLATION

1. Clean the groove on top of fuel tank.
2. Place new fuel module o-ring (8) into groove on top of fuel tank (**Figure 23-15, Page 23-20**).
3. Lower fuel pump module (1) into fuel tank noting correct orientation marked before removal. **See following NOTE and CAUTION.**

NOTE: If equipped with a fuel level sending unit, carefully maneuver module so as to avoid damaging the float arm mechanism.

⚠ CAUTION

- Ensure o-ring stays seated in place during fuel pump module installation.
4. Install hold down ring (6) and ground wire (7) with hardware (5) and tighten in a crisscross pattern to 66 in·lb (7.5 N·m). **See following WARNING.**

⚠ WARNING

- Always install ground wires during reassembly.
5. Tighten fuel tank retaining strap screw (9) to 26.5 in·lb (3 N·m).
 6. Connect fuel line (3) to fuel pump module (1). **See Fuel Line Installation on page 23-17. See following DANGER.**

⚠ DANGER

- Ensure line is connected properly to avoid a leak that can cause a fire.
7. Connect wire harness plug (2) to fuel pump module (1).
 8. Clean spilled and remove any drained gasoline from the area.
 9. Connect battery. **See Connecting the Battery-Gasoline Vehicles on page 1-5.**
 10. Place the Forward/Reverse handle in the NEUTRAL position, chock the wheels, and the neutral lockout switch in the MAINTENANCE position (**Figure 26-1, Page 26-1**).
 11. Turn key switch to the ON position and check for fuel leaks. Repeat as necessary to build fuel pressure. Any leaks found must be fixed.

⚠ DANGER

- Repair all fuel leaks before returning the vehicle to service.
12. If no leaks are found, place the neutral lockout switch in the OPERATE position (**Figure 26-1, Page 26-1**).

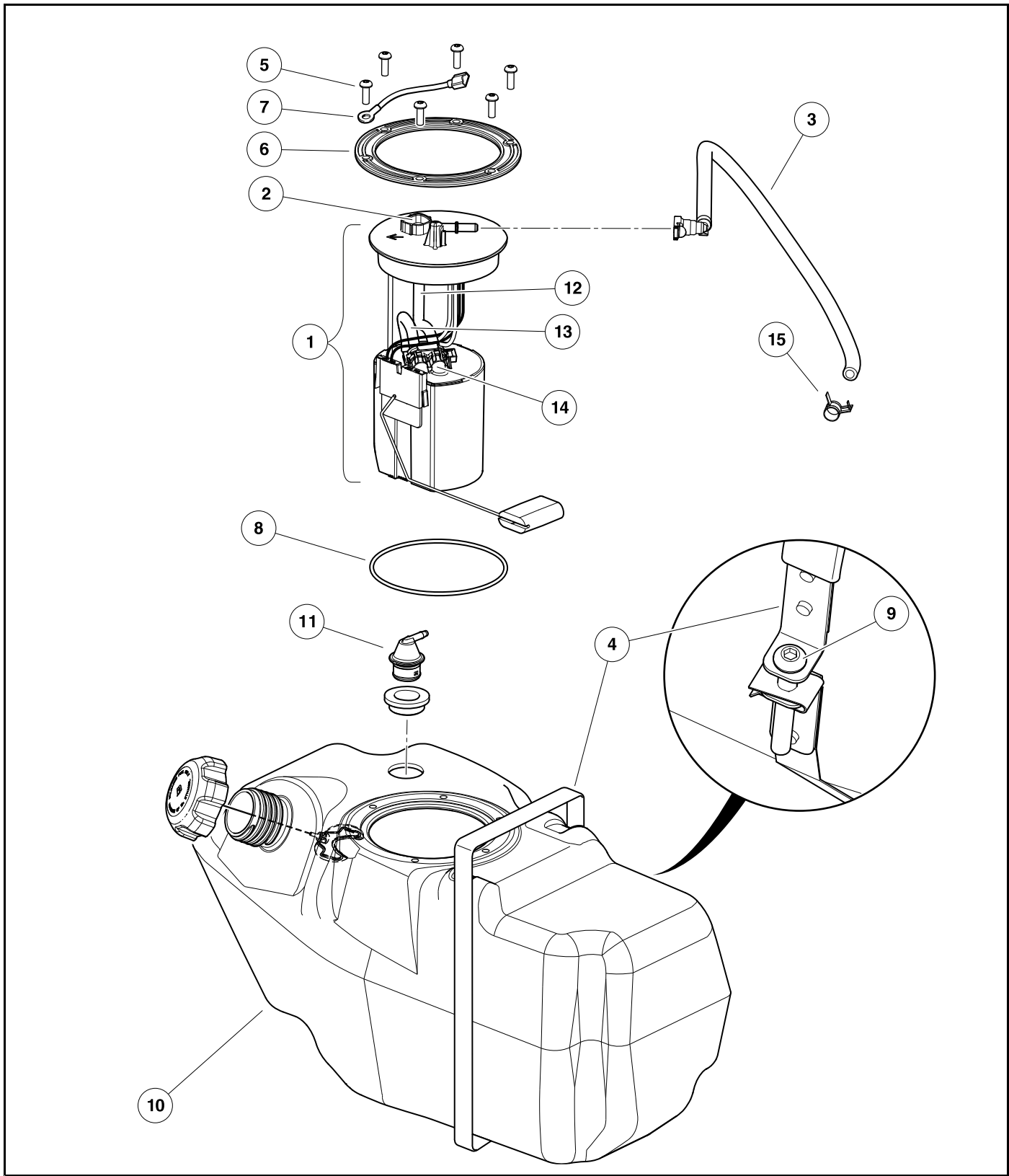

3052

Figure 23-15 Fuel System (Side-Fill) – Exploded View

FUEL TANK

See General Warnings on page 1-1.

GENERAL INFORMATION

The vehicle is equipped with a high impact, plastic fuel tank.

⚠ WARNING

- If the fuel tank is damaged, replace it. Do not attempt to repair it. See the following tank removal and disposal procedure.

⚠ CAUTION

- Add only unleaded fuel to the tank. Do not put oil in the fuel tank.

NOTE: This gasoline vehicle complies with the California Air Resources Board (CARB) and EPA evaporative emissions regulations when equipped with SAEJ30R9 1/4 in (6.3 mm) fuel vent hose (CC P/N 102865101) and 3/16 in (4.78 mm) fuel vent hose (CC P/N 1015137). To remain in compliance with California and EPA regulations, replace any fuel vent hose on this vehicle with Club Car P/N's 102865101, 1015137, or equivalent.

FUEL TANK REMOVAL

1. Place the Forward/Reverse handle in the NEUTRAL position, chock the wheels, and the neutral lockout switch in the MAINTENANCE position.
2. Turn key switch to OFF position and remove key.
3. Disconnect battery. **See Disconnecting the Battery-Gasoline Vehicles on page 1-5.**
4. Clean the top of the fuel tank (10) and fuel pump module (1) (**Figure 23-15, Page 23-20**).
5. Remove gas cap and siphon all fuel from tank into an approved container. **See following DANGER and WARNING.**

⚠ DANGER

- Gasoline – Flammable! Explosive! Do not smoke. Keep sparks and flames away from the vehicle and service area. Service only in a well-ventilated area.

⚠ WARNING

- Do not attempt to siphon fuel using a hose that does not have a built-in suction device.
 - Do not attempt to siphon fuel using your mouth.
6. Disconnect wire harness plug (2) from fuel pump module (1).
 7. Disconnect vent hose from fuel tank vent (11).
 8. Disconnect the fuel line (3) from the fuel pump module (1) and drain into an appropriate container. **See Fuel Line Removal on page 23-16. See following WARNING.**

⚠ WARNING

- Fuel may be under pressure. Use extreme caution when disconnecting fuel line to prevent the spray of fuel onto hot engine. See **Relieving Fuel Pressure** on page 23-2.
 - Carefully drain any fuel remaining in the hose or pump module into an approved container. Add drained fuel back into fuel tank or dispose of properly.
9. Disconnect fuel pump module ground wire (7).
 10. Loosen screw (9) securing fuel tank retaining strap (4) and remove fuel tank (10).

FUEL TANK DISPOSAL

1. Remove gas cap and fuel pump module from tank. See **Fuel Pump Module Removal** on page 23-18. The cap may be discarded or kept as a spare.
2. In a well-ventilated area, flush the fuel tank with water to remove any remaining fuel.
3. In a well-ventilated area, set the tank upside down so that the water can drain out of it. To make sure that the tank dries completely, allow the tank to sit for 24 hours. See following **CAUTION**.

⚠ CAUTION

- Dispose of wastewater and fuel tank in accordance with local, state, and federal laws and ordinances.

FUEL TANK STORAGE

1. Remove gas cap and fuel pump module from tank. See **Fuel Pump Module Removal** on page 23-18.
2. In a well-ventilated area, flush the fuel tank with water to remove any remaining fuel.
3. In a well-ventilated area, set the tank upside down so that the water can drain out of it. To make sure that the tank dries completely, allow the tank to sit for 24 hours.
4. Completely drain gas from fuel pump module and allow to module to dry.
5. After module is completely dry, install in fuel tank. See **Fuel Pump Module Installation** on page 23-18.
6. Store the tank upside down, with the cap installed, in a well-ventilated area.

FUEL TANK INSTALLATION

NOTE: This gasoline vehicle complies with the California Air Resources Board (CARB) and EPA evaporative emissions regulations when equipped with SAEJ30R9 1/4 in (6.3 mm) fuel vent hose (CC P/N 102865101) and 3/16 in (4.78 mm) fuel vent hose (CC P/N 1015137). To remain in compliance with California and EPA regulations, replace any fuel vent hose on this vehicle with Club Car P/N's 102865101, 1015137, or equivalent.

1. Place fuel tank (10) in vehicle.
2. Secure tank with retaining strap (4).
 - 2.1. Position the strap (4) in the indentation of the tank (10) (**Figure 23-15, Page 23-20**).
 - 2.2. Install the screw (9) into retaining strap (4) and tighten to 26.5 in·lb (3 N·m).
3. Connect fuel pump module ground wire (7) to main wire harness. See following **WARNING**.

⚠ WARNING

- Always install ground wires during reassembly.

4. Connect fuel line (3) to fuel pump module (1). **See Fuel Line Installation on page 23-17. See following DANGER.**

DANGER

- **Ensure line is connected properly to avoid a leak that can cause a fire.**

5. Connect wire harness plug (2) to fuel pump module (1).
6. Clean spilled and remove any drained gasoline from the area.
7. Connect battery. **See Connecting the Battery-Gasoline Vehicles on page 1-5.**
8. Add fuel to tank.
9. Place the Forward/Reverse handle in the NEUTRAL position, chock the wheels, and the neutral lockout switch in the MAINTENANCE position (**Figure 26-1, Page 26-1**).
10. Turn key switch to the ON position and check for fuel leaks. Repeat as necessary to build fuel pressure. Any leaks found must be fixed.

DANGER

- **Repair all fuel leaks before returning the vehicle to service.**

11. If no leaks are found, place the neutral lockout switch in the OPERATE position (**Figure 26-1, Page 26-1**).

FUEL FILTER

See General Warnings on page 1-1.

GENERAL INFORMATION

The fuel filter is located in the fuel tank. It is part of the fuel pump module assembly and should last the life of the vehicle; however, it is replaceable if the need should arise. In addition, the module assembly features a fuel pickup screen to catch larger particles before entering the fuel filter.

FUEL FILTER REMOVAL

1. Turn the key switch to the OFF position and remove the key, place the Forward/Reverse handle in the NEUTRAL position, and chock the wheels.
2. Disconnect battery. **See Disconnecting the Battery-Gasoline Vehicles on page 1-5.**
3. Remove fuel pump module (1). **See Fuel Pump Module Removal on page 23-18.**
4. Disconnect flex hoses (12 and 13) from filter (14) (**Figure 23-15, Page 23-20**).
 - 4.1. Pull hose retainer clip straight up and out of filter (14). Do not discard clip.
 - 4.2. Pull flex hoses (12 and 13) straight out of filter inlet and outlet.
5. Remove filter (14) from module (1) and dispose of properly.

FUEL FILTER INSTALLATION

⚠ CAUTION

- Fuel filter flex hoses are keyed to aid proper installation into fuel pump module.

NOTE: The fuel filter is keyed to the fuel pump module to prevent incorrect assembly.

The inlet and outlet flex hoses are keyed to the fuel filter ports to prevent incorrect assembly.

1. Orient fuel filter (14) and insert into fuel pump module (1) until fully seated (**Figure 23-15, Page 23-20**).
2. Connect flex hoses (12 and 13) to the fuel filter (14).
 - 2.1. Orient flex hoses (12 and 13) with matching port in filter (14) and push each hose end straight into filter until fully seated.
 - 2.2. Push hose retainer clip straight into filter (14) until fully seated.
3. Install fuel pump module (1). **See Fuel Pump Module Installation on page 23-18.**
4. Connect battery and spark plug wire(s). **See Connecting the Battery-Gasoline Vehicles on page 1-5.**
5. Place the Forward/Reverse handle in the NEUTRAL position, chock the wheels, and the neutral lockout switch in the MAINTENANCE position (**Figure 26-1, Page 26-1**).
6. Start the engine and check for fuel leaks. **See following DANGER.**

⚠ DANGER

- Repair all fuel leaks before operating the vehicle.
7. If no leaks are found, place the neutral lockout switch in the OPERATE position (**Figure 26-1, Page 26-1**).

FUELING INSTRUCTIONS – GASOLINE VEHICLE

See General Warnings on page 1-1.

⚠ DANGER

- Turn the key switch to the OFF position before fueling.
- Do not pour fuel into the fuel tank when the engine is hot or while it is running.
- Be sure the fuel tank ground wire on the tank is properly connected before fueling the vehicle.
- To avoid electric arc caused by static electricity, the fuel storage/pumping device must be grounded. If the pump is not grounded, the vehicle must be grounded to the pump before and during the fueling operation.
- If the vehicle has an all-weather enclosure installed, be sure the fuel tank is properly vented as shown in **Figure 23-16**.
- To avoid the possibility of fire, clean up any spilled fuel before operating the vehicle.

CAUTION

- Use unleaded gasoline only.
- Whenever possible, avoid using oxygenated and blended fuels.
- Do not use any fuel with an alcohol content that exceeds 10% by volume (such as E15 and E85). Ethanol is an alcohol that readily absorbs moisture, causing corrosion of fuel system components. It also damages neoprene and other plastic and rubber components. Use of these fuels in this vehicle will void the warranty.
- Do not repeatedly attempt to start a vehicle when the fuel pump is dry (no gas in tank). Doing so can damage the fuel pump.

NOTE: Whenever possible, avoid using oxygenated fuels and fuels that are blended with alcohol. Vehicles to be stored for extended periods should be prepared for storage as instructed. See **Preparing the Gasoline Vehicle for Extended Storage** on page 3-4.

1. Remove the fuel cap located on the passenger-side panel and fill the fuel tank with fresh unleaded gasoline only. See preceding **CAUTION** and **NOTE**.
2. Replace fuel cap on tank. Ensure cap is tightened securely (tighten until it clicks).

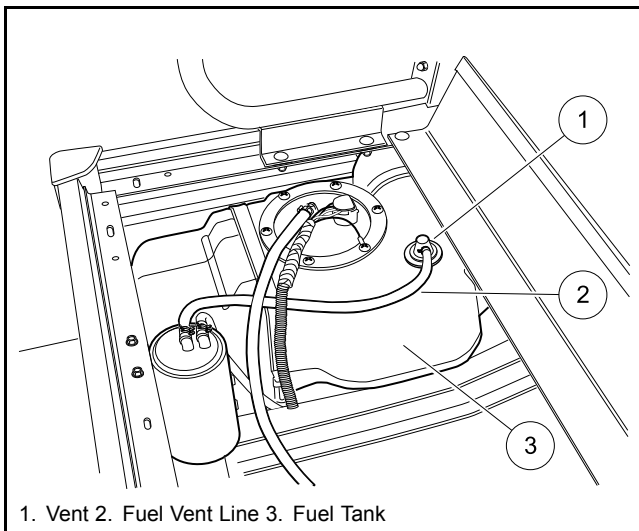

1. Vent 2. Fuel Vent Line 3. Fuel Tank

2832

Figure 23-16 Fuel Tank

Pagination Page

⚠ DANGER

- See General Warnings on page 1-1.

⚠ WARNING

- See General Warnings on page 1-1.

MUFFLER

MUFFLER REMOVAL

1. Disconnect battery and spark plug wire(s). **See Disconnecting the Battery-Gasoline Vehicles on page 1-5.**
2. If equipped, remove air deflector from top of engine.
3. Remove the locknut (1) securing the muffler (2) to its mounting bracket (**Figure 24-1, Page 24-2**).
4. Remove the hex nuts (3) and lock washers (4) at the cylinder head and remove muffler (2) from vehicle.

MUFFLER INSTALLATION

NOTE: Any time the muffler is removed from the vehicle, install a new exhaust gasket (5) (CC P/N 47539957001).

Two different exhaust gaskets have been used; one with a raised port opening, that has since been replaced by the other; a flat, metal-reinforced, graphite gasket. Follow instructions below for proper orientation of the exhaust gasket with raised port opening.

1. If muffler bracket (6) was loosened or removed, tighten bolts (9) to 17 ft·lb (23 N·m) and then bolts (7) to 50 ft·lb (68 N·m) (**Figure 24-1, Page 24-2**).
2. Replace exhaust gasket (5) on the cylinder head exhaust port studs with a new gasket. For exhaust gasket with raised port opening, orient gasket (5) with raised section of gasket up against the flange of the muffler.
3. Place muffler (2) into position and loosely secure it to mounting bracket with locknut (1) and to cylinder head with lock washers (4) and hex nuts (3).
4. Tighten hardware in the following order:
 - 4.1. At the cylinder head, tighten passenger-side hex nut (3) to 15 ft·lb (20 N·m).
 - 4.2. At the cylinder head, tighten driver-side hex nut (3) to 15 ft·lb (20 N·m).
 - 4.3. At the mounting bracket, tighten locknut (1) to 34 ft·lb (46 N·m).
5. If equipped, install air deflector on top of engine.
6. Connect battery and spark plug wire(s). **See Connecting the Battery-Gasoline Vehicles on page 1-5.**
7. Place the shifter handle in NEUTRAL, the neutral lockout switch in MAINTENANCE, and chock the wheels.
8. Start the engine and check for exhaust leaks and proper engine operation. **See following DANGER.**

⚠ DANGER

- Do not operate gasoline vehicle in an enclosed area without proper ventilation. The engine produces carbon monoxide, which is an odorless, deadly poison.

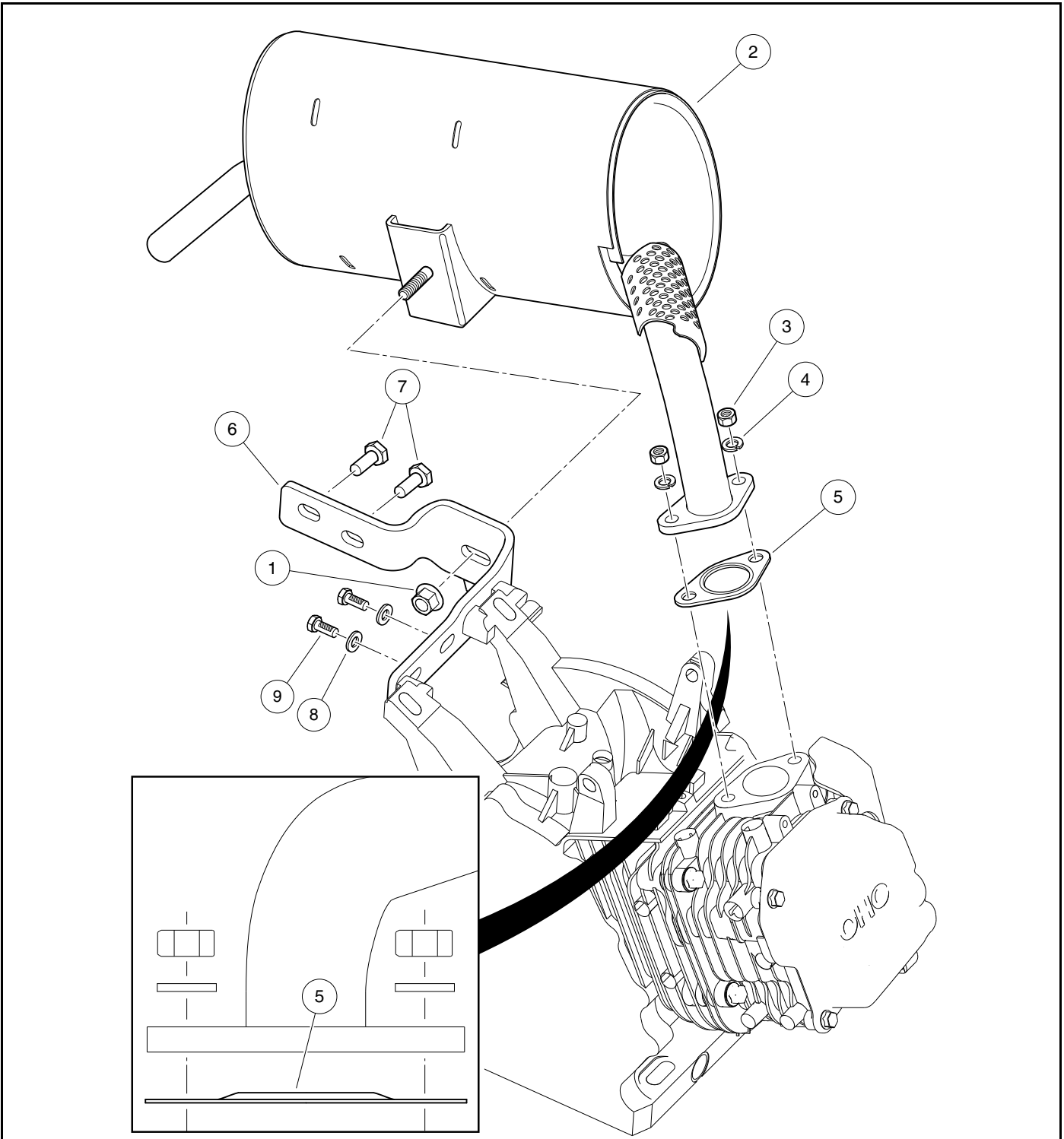

3112a

Figure 24-1 Exhaust System

⚠ DANGER

- See General Warnings on page 1-1.

⚠ WARNING

- See General Warnings on page 1-1.

GENERAL INFORMATION

The torque converter consists of a drive clutch, a driven clutch, and a drive belt. The drive clutch, which is mounted to the engine, is in the open position when the engine is at idle. At this point, the belt is riding at a low position (smaller diameter) on the drive clutch. The driven clutch is mounted on the transaxle. It is in the closed position, and the drive belt is riding at a high position (large diameter) on it when the engine is at idle.

At the point of clutch engagement, the speed ratio of the drive clutch to the driven clutch provides excellent starting and low-speed torque.

As engine speed increases, centrifugal force on internal weights close the drive clutch, pushing the belt up to a higher position on the clutch (increasing the diameter of the belt loop). As the diameter of the belt loop increases at the drive clutch, the driven clutch is forced open as the diameter of its belt loop decreases.

On steep grades, or when the vehicle is heavily loaded, higher torques are achieved through the use of a torque-sensing ramp device on the driven clutch. This device overcomes the force of the centrifugal weights to close the driven clutch and open the drive clutch, thus increasing axle torque with little or no change in engine RPM.

The engine and torque converter rotate counter-clockwise as viewed from the clutch side of the engine.

To provide optimum performance for the engine and powertrain, the vehicle uses a pair of tuned clutches.

To properly assemble and disassemble the torque converter, the following tools should be used:

- Clutch Tools (**Figure 25-1, Page 25-2**).
- Scribe or small pick (not included with clutch tools).

TROUBLESHOOTING

See General Warnings on page 1-1.

Maintaining proper adjustment of the engine and governor, as well as the torque converter, is essential to the troubleshooting process. If these adjustments are within specifications and, when climbing a steep hill, the engine begins to lose RPM before the drive belt reaches the top of the driven clutch, there is a torque converter problem.

If the torque converter is not operating properly, perform the following steps:

1. Check the governor and throttle settings. **See Engine Control Linkages on page 23-6.**
2. Inspect the driven clutch for dirt and dust buildup on its component parts. Clean the driven clutch with water to remove any dust or dirt, then drive the vehicle and check for proper operation.

3. If cleaning the driven clutch does not solve the problem, disassemble and thoroughly clean all parts of the drive clutch. Be sure to clean the plastic drive buttons (7) (Figure 25-3, Page 25-4).

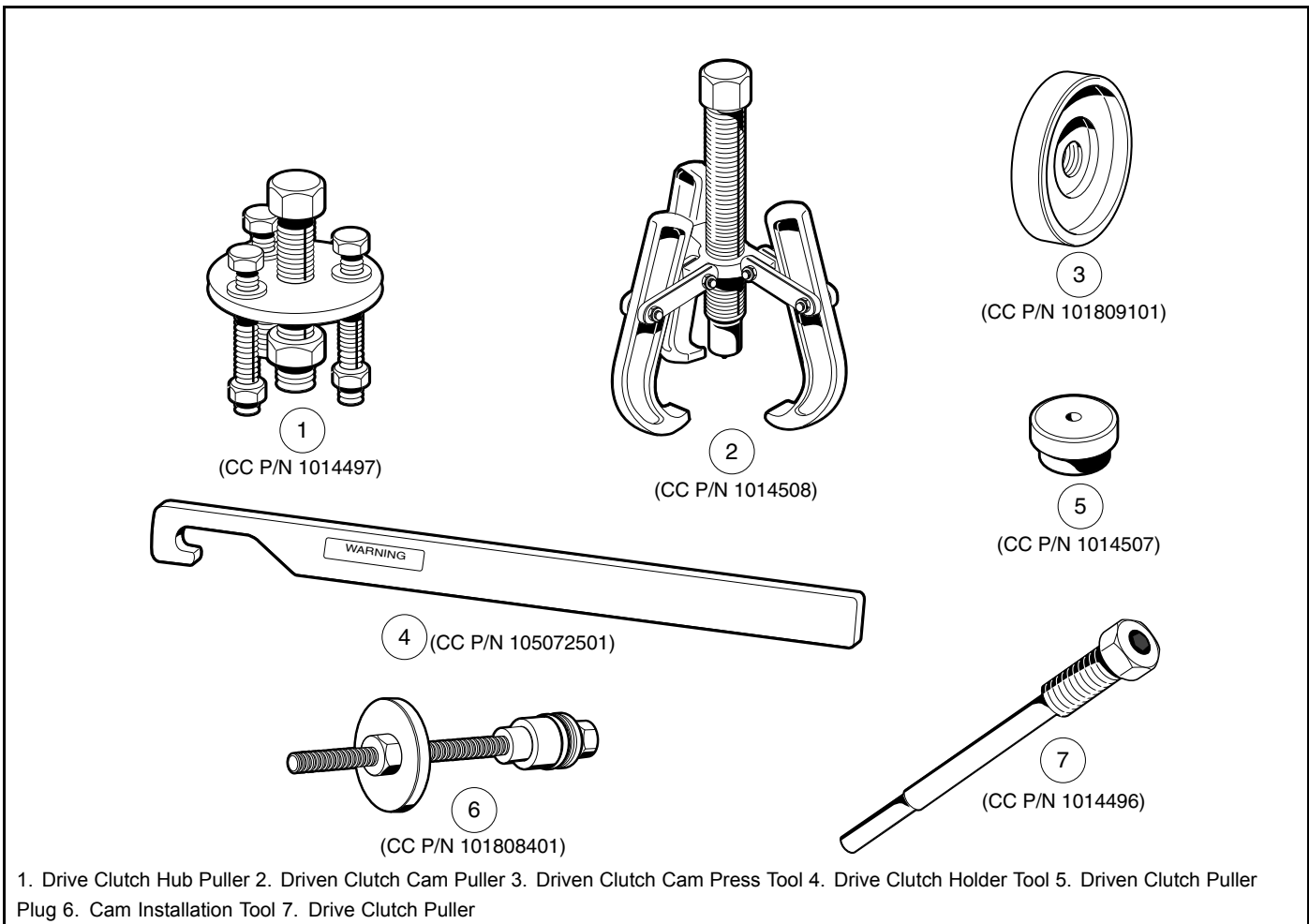

2963

Figure 25-1 Clutch Tools

DRIVE BELT

See General Warnings on page 1-1.

The drive belt should be inspected semiannually for wear and (or) glazing. If it is excessively worn, frayed, or glazed, replace the belt.

As the drive belt wears, the engine RPM will increase to compensate for the change in torque converter ratio. This will keep the vehicle's maximum ground speed correct. **Section 2 — Vehicle Specifications**

DRIVE BELT REMOVAL

1. Disconnect battery and spark plug wire(s). See **Disconnecting the Battery-Gasoline Vehicles on page 1-5**.
2. Grasp the belt midway between the drive (2) and driven (1) clutches. Lift upward on the belt to force the sheaves of the driven clutch (1) apart, then roll the belt off the driven clutch by rotating the clutch counterclockwise (**Figure 25-2, Page 25-3**). See following **CAUTION**.

⚠ CAUTION

- Make sure fingers are not underneath the belt when rolling the belt off the driven clutch.

3. Remove the belt from the drive clutch (2).

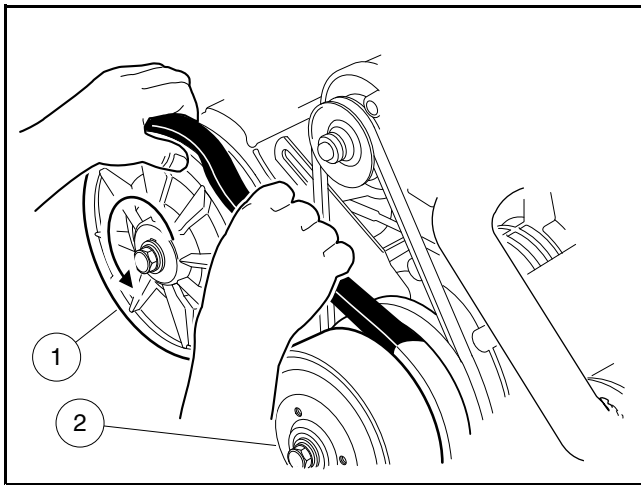

594

Figure 25-2 Drive Belt Removal

DRIVE BELT INSTALLATION

1. Position the new belt on the drive clutch (2), then start the belt over the top of the driven clutch (1).
2. With the belt started onto the driven clutch (1), rotate the driven clutch counterclockwise and roll the belt over the outer, moveable sheave.
3. Connect battery and spark plug wire(s). See **Connecting the Battery-Gasoline Vehicles on page 1-5**.

DRIVE CLUTCH

See General Warnings on page 1-1.

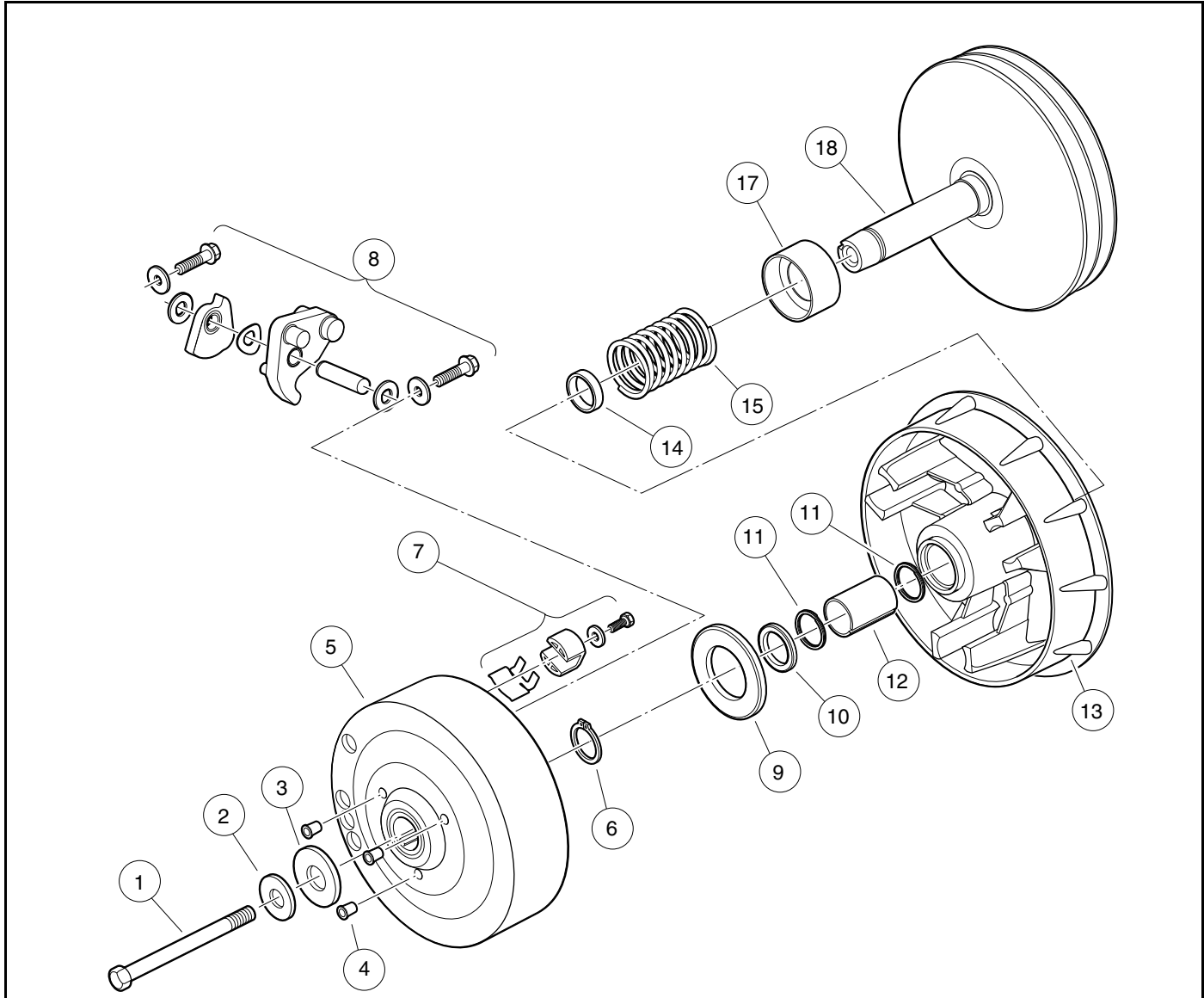

1. Screw, 3/8-24 x 5.75, Patch	10. Retainer
2. Washer, Hard, M10	11. Ring, Spiral Backup
3. Washer, 3/8, Type A, Flat	12. Bushing, Split, Drive Clutch
4. Cap Plug	13. Sheave, Moveable, Drive
5. Drive Hub Assy, Drive Clutch	14. Spacer, Fixed Face Shaft
6. Ring, 0.810 in. (20.5 mm) Internal Retaining	15. Spring, Drive Clutch
7. Drive Clutch Button	16. No Item to Show

8. Drive Clutch Weight	17. Spacer, Idler, Drive
9. Thrust Washer	18. Sheave, Fixed, Drive

2960

Figure 25-3 Drive Clutch – Exploded View

CAUTION

- Be very careful when handling the clutches. A clutch that has been dropped will not be properly balanced. If either clutch is dropped, assume that it is damaged and replace it.

DRIVE CLUTCH REMOVAL

1. Remove the drive belt as instructed. See Drive Belt Removal on page 25-3.
2. Loosen starter/generator mounting and adjusting hardware and remove starter belt. See WARNING “Moving parts! Do not...” in General Warnings on page 1-1.

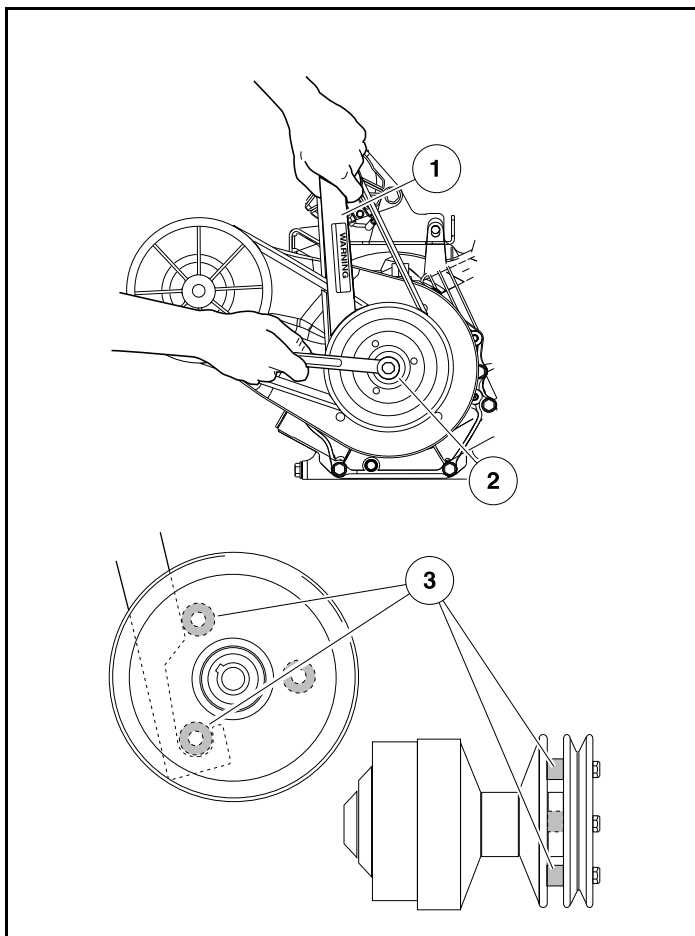

2962

Figure 25-4 Loosen Retaining Bolt

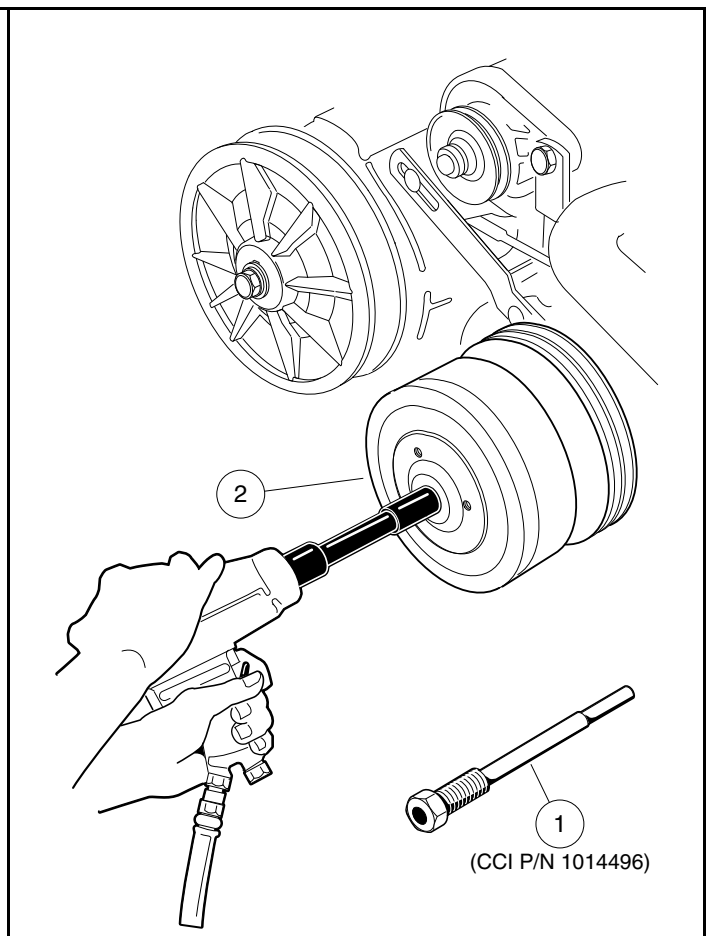

596

Figure 25-5 Drive Clutch Removal

3. Place chocks at the front wheels and lift the rear of the vehicle with a chain hoist or floor jack. Place jack stands under the chassis to support the vehicle. The weight of the powertrain will allow the centerline of the drive clutch to drop below the frame I-beam for access to the bolt securing the drive clutch. See following WARNING.

⚠ WARNING

- Lift only one end of the vehicle at a time. Use a suitable lifting device (chain hoist or hydraulic floor jack) with 1000 lb. (454 kg) minimum lifting capacity. Do not use lifting device to hold vehicle in raised position. Use approved jack stands of proper weight capacity to support the vehicle and chock the wheels that remain on the floor. When not performing a test or service procedure that requires movement of the wheels, lock the brakes.
4. Remove the drive clutch retaining bolt (1) and mounting washers (2 and 3) (Figure 25-3, Page 25-4). See also Figure 25-4, Page 25-5. See following NOTE.

NOTE: The drive clutch mounting bolt has right-hand threads.

The crankshaft has right-hand threads at the clutch mounting hole.

- 4.1. Use the drive clutch holder tool (1) while tightening or loosening the drive clutch retaining bolt (2) (Figure 25-4, Page 25-5).
- 4.2. Hook clutch holder on boss (3) of pulley located behind drive clutch and push against the adjacent boss with holder.
5. Lubricate the threaded portion of the clutch puller tool (1) with a light oil and thread the clutch puller tool into the clutch retaining bolt hole (Figure 25-5, Page 25-5).
6. Use a 1/2-in. drive air wrench to tighten the clutch puller tool. The drive clutch (2) will pull free of the crankshaft.
7. Support the drive clutch assembly in your hand and back the clutch puller tool out of the crankshaft.

⚠ CAUTION

- Do not hit or tap the clutch with a hammer. Do not pry the clutch. These actions will damage the clutch.

DRIVE CLUTCH CLEANING AND INSPECTION

1. Use a dry, lint-free cloth to clean clutch parts.

⚠ CAUTION

- Do not lubricate the drive clutch. Lubricants attract dirt and dust, which interfere with proper clutch operation.
 - Use only a dry cloth to lightly wipe the shaft of the fixed sheave (18) (Figure 25-3, Page 25-4). Do not use a brush or steel wool. These will damage the surface of the shaft.
 - Do not use solvents. Solvents will damage the lubricating characteristics of the bushings.
2. Inspect the belt contact surfaces of the clutch sheaves for wear. If any area of a sheave contact surface has wear of 0.060 in. (1.52 mm) or more, the clutch should be replaced.

DRIVE CLUTCH DISASSEMBLY

⚠ CAUTION

- The drive clutch is balanced as an assembly. Before disassembly, make match marks on the drive clutch hub and on the moveable sheave so they can be reassembled in the same positions (Figure 25-6, Page 25-7).

1. Make match marks on the drive clutch hub and on the moveable face (Figure 25-6, Page 25-7).
2. Remove the drive clutch hub (5) (Figure 25-3, Page 25-4):
 - 2.1. Remove the three plugs (4) from the clutch puller attachment holes.
 - 2.2. Thread the center bolt of the Drive Clutch Hub Puller (1) (CC P/N 1014497) into clutch until the stop nut touches the clutch, then back the bolt out one-half turn (Figure 25-7, Page 25-7).
 - 2.3. Thread the three small bolts of the puller into corresponding holes in the clutch. Tighten bolts evenly, making sure the face of the puller plate is parallel to the face of the clutch (Figure 25-7, Page 25-7).
 - 2.4. Unscrew the puller center bolt out of the clutch to pull drive clutch hub off.

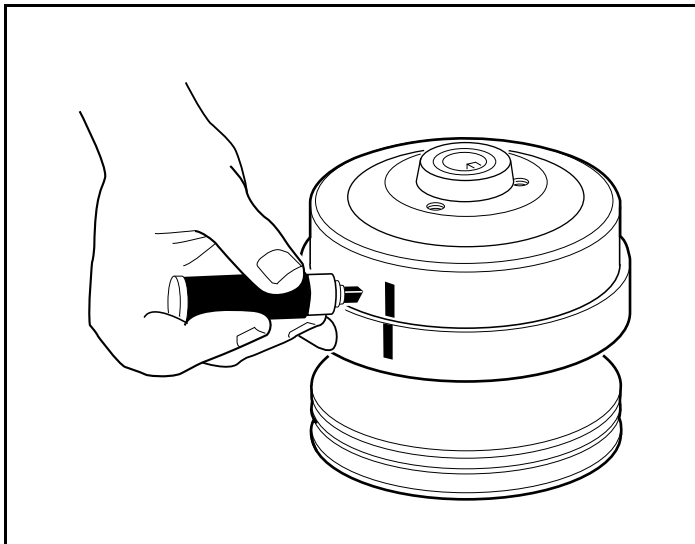

598

Figure 25-6 Mark Drive Clutch Hub

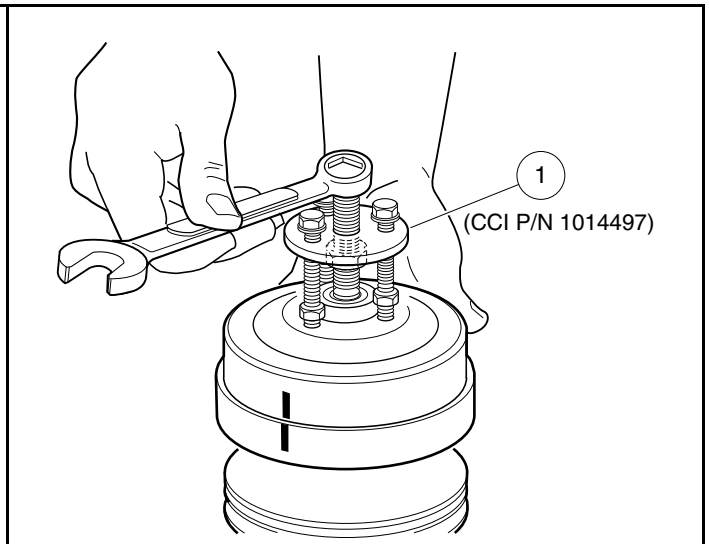

599

Figure 25-7 Remove Drive Clutch Hub

3. Remove the thrust washer (9) from the moveable sheave (13) (Figure 25-3, Page 25-4).
4. Remove the drive buttons (3) by removing the screws (1), flat washers (2), and drive button take-up springs (4) as shown (Figure 25-8, Page 25-8).

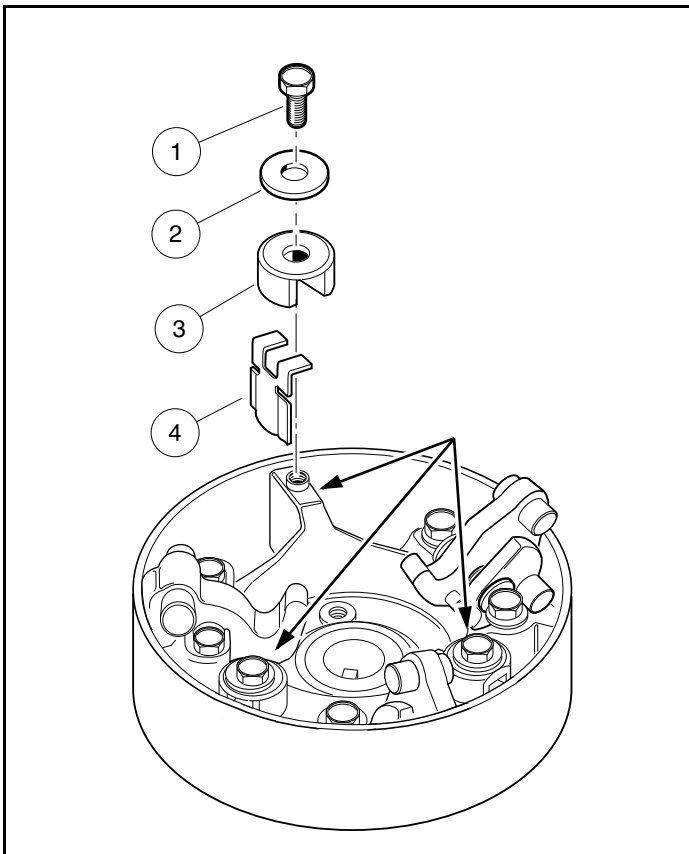

3053

Figure 25-8 Drive Button Mounting

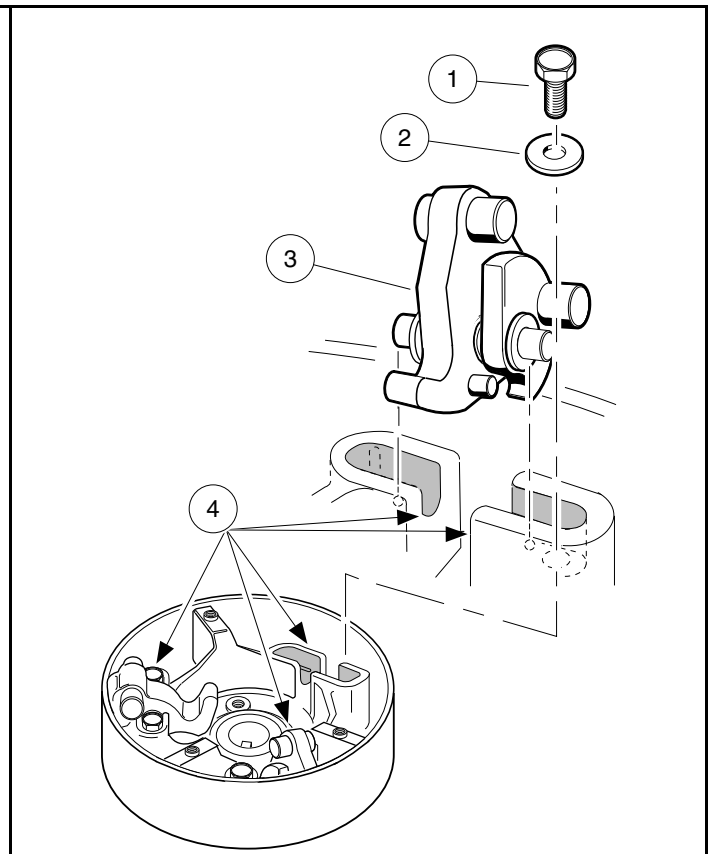

601

Figure 25-9 Weight Position

5. Remove the clutch weights:
 - 5.1. Remove the screws (1) and flat washers (2) attaching the weights (3) as shown (Figure 25-9, Page 25-8).
 - 5.2. Pull the weight assemblies (3), with pins, from slots (4) in the clutch. **See following NOTE.**
- NOTE:** Before removing, note the orientation of the wave washer (1) and secondary weight (2) on the primary weight (3) (Figure 25-10, Page 25-9).
- 5.3. Remove the plastic washers, weights (2 and 3) and wave washer (1) from the pin (4). Retain all parts.

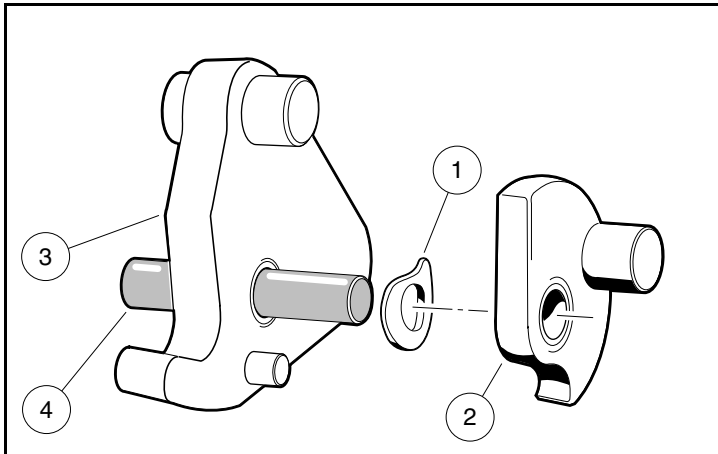

602

Figure 25-10 Primary and Secondary Weights, Wave Washer and Pin

- Remove the retaining ring (6) from the shaft of the fixed sheave (18) and slide the moveable sheave (13) off the shaft (**Figure 25-3, Page 25-4**). See following **NOTE**.

NOTE: If the moveable sheave is removed from the hub of the fixed sheave, the spiral back-up rings (11) must be replaced with new rings (**Figure 25-3, Page 25-4**).

- Remove the spacer (14) and spring (15) (**Figure 25-3, Page 25-4**).
- Use a scribe or small pick to remove the spiral backup rings (11) from each end of the bore in the fixed sheave (**Figure 25-3, Page 25-4**). See also **Figure 25-11, Page 25-9**. Discard the rings.

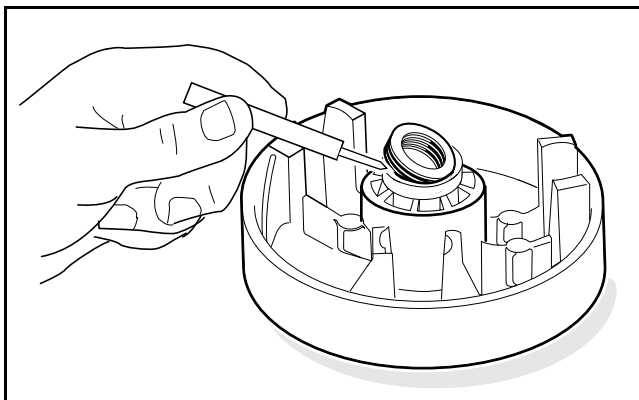

605

Figure 25-11 Spiral Back-up Rings

INSPECTION OF DRIVE CLUTCH PARTS

- Inspect the idler spacer (17) for smoothness (**Figure 25-3, Page 25-4**).
- Inspect the bore of the moveable sheave (13) for scarring or wear. The moveable sheave must be replaced if the bore is worn to a diameter of 0.883 in. (22.4 mm) or larger (**Figure 25-3, Page 25-4**).
- Inspect the steel shaft on the fixed sheave (18). There should be no measurable wear anywhere on the shaft. Replace the shaft if it is worn, scratched, or damaged.
- Inspect the thrust washer (9) for wear. If it is worn more than 0.030 in. (0.76 mm), turn it over or replace it with a new one.

5. Inspect the primary weights (8) and the hub casting for wear. If the primary weights show signs they are touching the casting, the tips of the weights have worn beyond specification and they must be replaced.
6. Inspect the pins on the primary weights (8). There should be no measurable wear. Replace them if they are worn, scratched, or damaged.
7. Inspect the drive belt pulley sheaves for excessive wear or damage. If the sheaves are excessively worn or damaged, replace the entire fixed sheave.

DRIVE CLUTCH ASSEMBLY

1. Install the spring (15) into the cup of the idler spacer (17).
2. Install the spacer (14) onto the shaft of the fixed sheave.
3. Install a new spiral backup ring (11) in each end of the bore of the moveable sheave (13).
4. Install the moveable sheave (13) onto the shaft of the fixed sheave (18).

⚠ CAUTION

- To avoid damaging the spiral back-up rings, be very careful when installing the moveable sheave.

- 4.1. Rotate the moveable sheave clockwise while installing it onto the shaft.
- 4.2. Install the retaining ring (6) (**Figure 25-3, Page 25-4**).
5. Install the primary weights (3) on the mounting pins (4) (**Figure 25-10, Page 25-9**).
6. Install a wave washer (1) on each mounting pin (4). Make sure that the concave side of the washer faces the side of the primary weight (3) with the small guide pin protruding from it (**Figure 25-10, Page 25-9**).
7. Install the secondary weights (2) onto the mounting pins (4) with the weight pins on the secondary weights pointing away from the primary weights (3). The wave washers should be between the primary and secondary weights (**Figure 25-10, Page 25-9**).
8. Install white plastic flat washers on each end of the mounting pin and push them against the outside surfaces of the weights. Center the weights and washers on the mounting pin (**Figure 25-12, Page 25-10**).
9. Install the weight assemblies into the slots (4) in the hub casting (**Figure 25-9, Page 25-8**). Make sure the mounting pin protrudes an equal amount on each side of the weights when the assemblies are in position (**Figure 25-12, Page 25-10**).

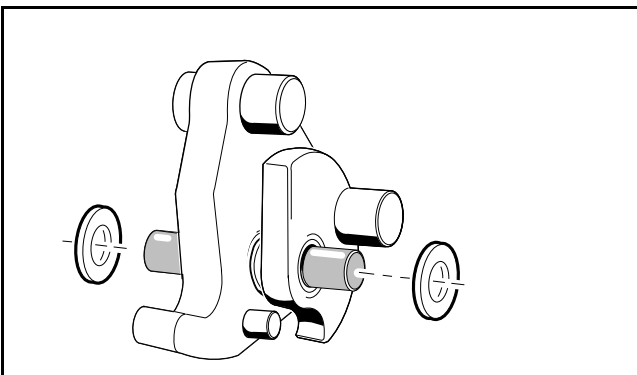

606

Figure 25-12 Install White Washers

10. Install the 1/4-20 bolts (1) and washers (2) and tighten them to 10 ft-lb (13 N·m) (**Figure 25-9, Page 25-8**).
See following NOTE.

NOTE: Make sure there is at least a (minimum) gap of 0.020 in. (0.51 mm) between each end of the mounting pin and the mounting bolt.

11. Install three drive button take-up springs.
- 11.1. Install each spring on right-hand side of the three button mounting posts (when looking into the interior of the clutch drive hub, and with the rib at a twelve o'clock position) as shown (**Figure 25-13, Page 25-11**).
12. Compress each take-up spring and install the drive button over the rib and take-up spring (**Figure 25-8, Page 25-8**).
13. Install a drive button retaining bolt (1) with flat washer (2) through each button (3) and into the rib. Tighten the bolts to 34 in·lb (3.8 N·m) (**Figure 25-8, Page 25-8**).
14. Install the thrust washer (9) onto the moveable sheave (13) (**Figure 25-3, Page 25-4**).
15. Install the hub assembly (5) on the moveable sheave (13) and align the match marks made before disassembling the clutch. Press the hub assembly on by hand.
16. Replace the three plastic plugs (4) into the holes (**Figure 25-3, Page 25-4**).

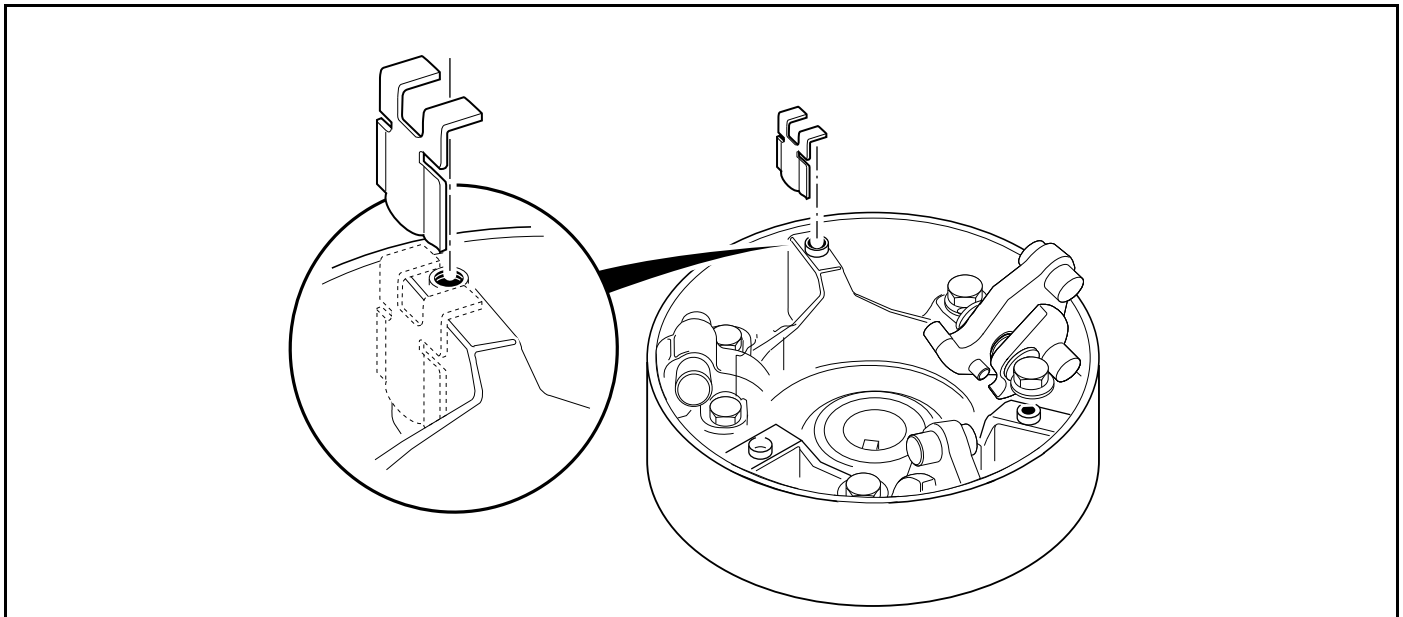

3054

Figure 25-13 Correct Orientation of Drive Button Take-up Springs

DRIVE CLUTCH INSTALLATION

1. Place the drive clutch assembly on the crankshaft taper. Position the mounting washers (2 and 3) on the bolt (1) and start the bolt into the crankshaft (**Figure 25-3, Page 25-4**). **See following NOTE.**

NOTE: The drive clutch retaining bolt has right-hand threads. The manufacturer recommends replacing the drive clutch retaining bolt (CC PN 103976101) when installing the drive clutch. If a new bolt is not available, clean the threads of the original bolt and apply Loctite® 242 to the threaded end prior to installation.

2. Tighten the drive clutch retaining bolt (1) to 35 ft·lb (47.5 N·m) (**Figure 25-3, Page 25-4**).
3. Install the starter/generator belt and adjust belt tension as instructed. **See Belt Tension Adjustment for EFI Engines, Section 20, Page 20-13.**
4. Install the drive belt as instructed. **See Drive Belt Installation on page 25-3.**
5. Connect battery and spark plug wire(s). **See Connecting the Battery-Gasoline Vehicles on page 1-5.**
6. Drive the vehicle and check for proper operation.

DRIVEN CLUTCH

See General Warnings on page 1-1.

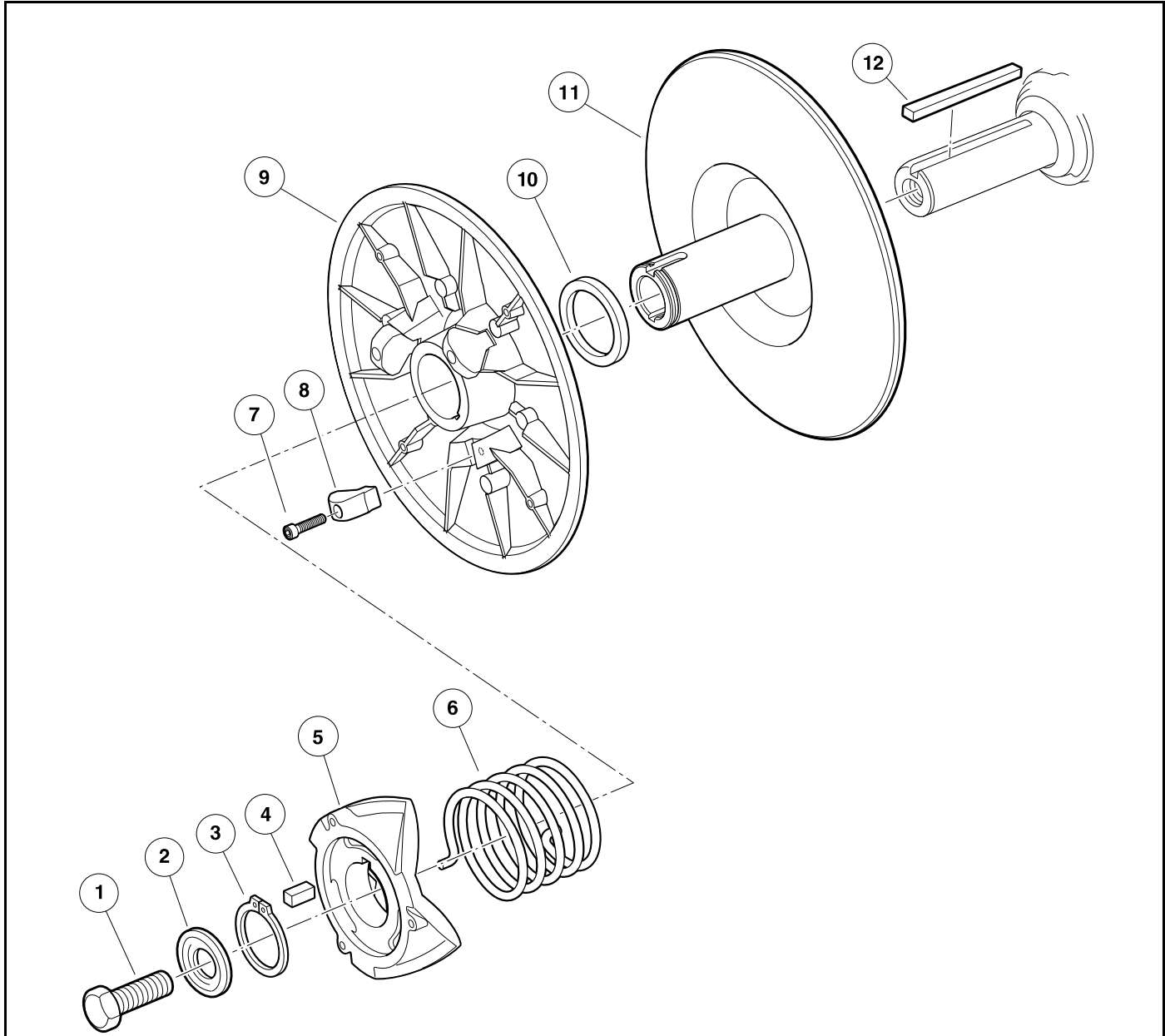

1. Screw, 5/16-18 X 3/4 Hex-Head with Patch

2. Washer, Driven Clutch

3. Ring, Retaining

4. Key, Driven Clutch

7. Screw, #8-32 X 3/4, Socket-Head Cap

8. Button, Drive

9. Sheave, Movable, Driven

10. Washer, Acetal, Driven Clutch

5. Cam, Driven Clutch	11. Sheave, Fixed, Driven
6. Spring, Driven Clutch, 55 Degree	12. Key, 3/16 in. (4.7 mm) Square X 1.50 in. (38 mm) Long

2961

Figure 25-14 Driven Clutch – Exploded View

DRIVEN CLUTCH REMOVAL

1. Remove the drive belt as instructed. **See Drive Belt Removal on page 25-3.**
2. Remove the bolt (1) and mounting washer (2) from the transaxle input shaft (**Figure 25-14, Page 25-12**).
3. Grasp the driven clutch assembly and slide it off the shaft.
4. Leave the key (12) in the keyway.

DRIVEN CLUTCH DISASSEMBLY

⚠ CAUTION

- **The driven clutch is balanced as an assembly. Before disassembly, make match marks on the driven clutch fixed sheave and moveable sheave so they can be reassembled in the same positions.**
1. Make match marks on the driven clutch fixed sheave and on the moveable sheave to maintain balance upon reassembly.
 2. Using external snap ring pliers, remove the retaining ring (4) (**Figure 25-15, Page 25-14**). **See following WARNING.**

⚠ WARNING

- **Do not place fingers under the cam when removing the cam. The moveable face may spin when the cam buttons release from the cam ramps, resulting in severe personal injury.**
3. Insert a puller plug (2) (CC P/N 1014507) (**Figure 25-16, Page 25-14**) into the shaft bore and use a driven clutch cam puller (1) (CC P/N 1014508) to remove the cam (3) from the fixed sheave.
 4. Remove the spring (6) (**Figure 25-14, Page 25-12**).
 5. Retain the key (4).
 6. Slide the moveable sheave (9) off the fixed sheave (11).

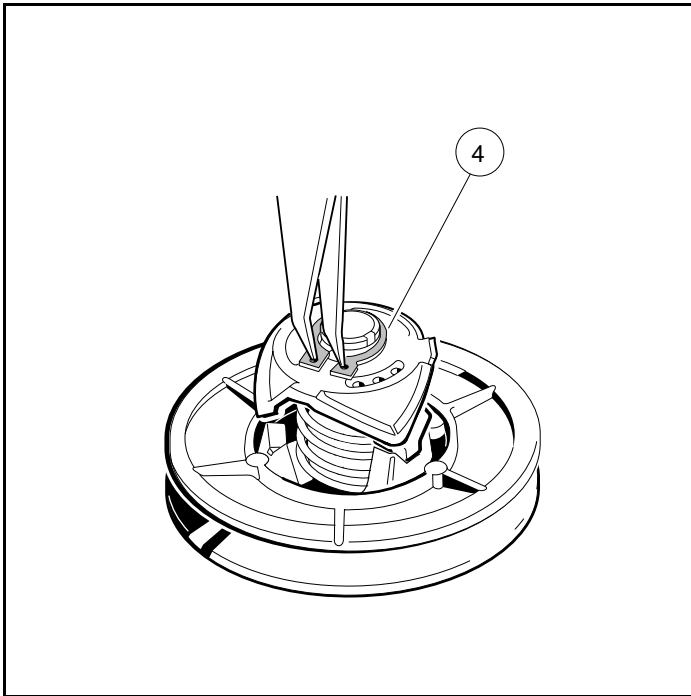

608

Figure 25-15 Remove Retaining Ring

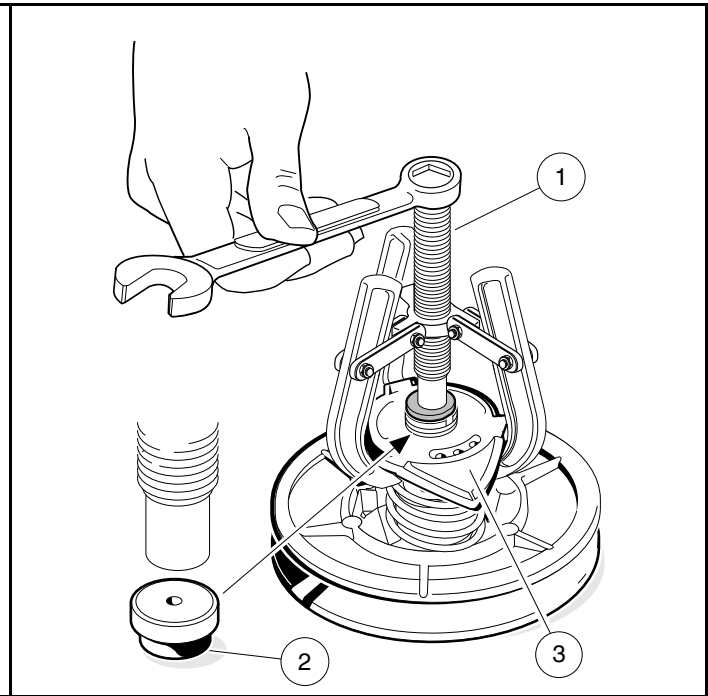

609

Figure 25-16 Driven Clutch Disassembly

DRIVEN CLUTCH INSPECTION

1. Inspect the cam (5) for excessive wear (**Figure 25-14, Page 25-12**). Replace it if necessary.
2. Inspect the drive buttons (8) for excessive wear. Replace if necessary. To remove the drive buttons (8), remove the socket-head cap screws (7) and then the buttons.
3. Inspect the smooth surface on the fixed and moveable sheaves. Sheaves must be replaced if surfaces are worn more than 0.060 in. (1.5 mm).
4. Inspect the bronze bearing in the moveable sheave. If the bearing bore diameter is more than 1.384 in. (35.15 mm), the entire moveable sheave must be replaced.
5. Inspect the shaft of the fixed sheave. There should be no noticeable wear. Replace the fixed sheave if it is worn, scratched or damaged.

DRIVEN CLUTCH ASSEMBLY

1. Place the three drive buttons (8) in position. Apply one drop of Loctite® 222 to each of the socket-head cap screws (7) and then install and tighten them to 8 in·lb (0.9 N·m) (**Figure 25-14, Page 25-12**).
 2. Slide the acetal washer (10) and moveable sheave (9) onto the fixed sheave (11).
 3. Place the end of the spring (6) into the hole in the moveable sheave (9).
 4. Install the key (4) into the keyway of the fixed sheave (11) shaft.
 5. Holding the cam (5) in position for assembly on the shaft, install the other end of the spring (6) into the center spring hole of the cam. Rotate the cam until the keyway is aligned with the key (4) on the fixed sheave, and then start the cam onto the shaft approximately 1/4 to 3/8 in. (6.3 to 9.5 mm).
- 5.1. **Press Assembly Process:**
- 5.1.1. Place the clutch assembly in a press and position the cam press tool (CC P/N 101809101) on the cam (2) as shown (**Figure 25-17, Page 25-15**).

- 5.1.2. Hold the fixed sheave (3) and rotate the moveable sheave (1) one-third turn counterclockwise, then press the cam (2) onto the fixed sheave (**Figure 25-17, Page 25-15**). The match marks made before disassembly should now align.
- 5.1.3. Install the retaining ring (4) (**Figure 25-15, Page 25-14**). **See following NOTE.**

NOTE: The retaining ring (4) can be reused if the O.D. does not exceed 1.607 in. (40.82 mm); otherwise, it must be replaced with a new ring (CC P/N 1014080).

- 5.1.4. While holding onto the cam, tap the end of the fixed sheave lightly with a plastic mallet until the cam seats against the retaining ring (4). **See following CAUTION.**

⚠ CAUTION

- Do not use a metal hammer to tap the fixed sheave. A metal hammer will damage the shaft.

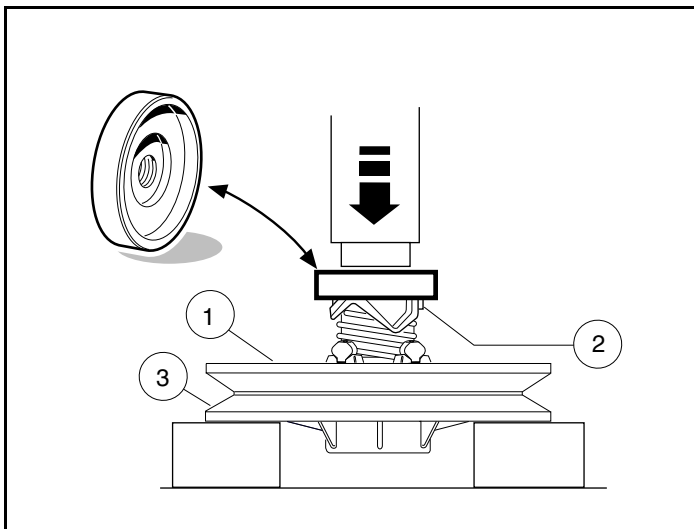

611

Figure 25-17 Cam Press Tool

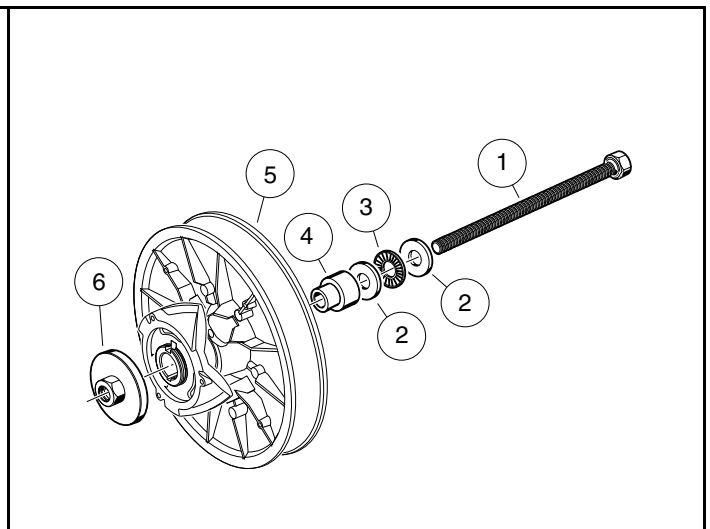

612

Figure 25-18 Cam Installation Tool

5.2. Field Assembly Process:

NOTE: This process is for field assembly requirements where hydraulic and pneumatic press equipment is not available. Use the cam installation tool (CC P/N 101808401) for this process.

- 5.2.1. With the clutch loosely assembled, set the edge of the clutch body (5) on a clean, flat surface (**Figure 25-18, Page 25-15**).
- 5.2.2. Assemble the threaded bolt (1) through the washer (2), the thrust bearing assembly (3), the second washer (2), and the hub guide (4).

NOTE: It is very important that the bolt, washers, and thrust bearing assembly be assembled in the order described and shown.

- 5.2.3. Slide the bolt (1) through the clutch body (5) until the threaded bolt, washers, bearing, and hub guide are against the fixed sheave (**Figure 25-18, Page 25-15**).
- 5.2.4. Hold the clutch assembly and cam installation tool together and place the fixed sheave down on spaced blocks (**Figure 25-17, Page 25-15**).
- 5.2.5. Place the cam press hub (6) onto the cam installation bolt and thread it down onto the cam hub, centering the press hub onto the cam hub.

- 5.2.6. Hold the fixed sheave of the clutch (5) and rotate the moveable sheave of the clutch one-third turn counterclockwise (**Figure 25-18, Page 25-15**). The match marks made before disassembly should now align.
- 5.2.7. Use two wrenches and hold the bolt head (1) while tightening the cam press hub (6) to press the cam onto the keyed shaft. Advance the press hub (6) until it is firm against the shaft end.
- 5.2.8. Remove the cam press hub (6) and installation tool.
- 5.2.9. Install the retaining ring (4) (**Figure 25-15, Page 25-14**).

NOTE: The retaining ring (4) can be reused if the O.D. does not exceed 1.607 in. (40.82 mm); otherwise, it must be replaced with a new ring (CC P/N 1014080).

DRIVEN CLUTCH INSTALLATION

1. To install the driven clutch, reverse the removal procedure. Make sure that the washer (2) is mounted with the flat portion of the washer against the driven clutch (**Figure 25-14, Page 25-12**). Secure with a new bolt (1).
See following NOTE.

NOTE: The bolt (1) must be replaced with a new bolt (CC P/N 102242101) containing a locking patch that will prevent the bolt from loosening.

2. Tighten the bolt (1) to 18 ft·lb (24.4 N·m).
3. Connect battery and spark plug wire(s). **See Connecting the Battery-Gasoline Vehicles on page 1-5.**

⚠ DANGER

- See General Warnings on page 1-1.

⚠ WARNING

- See General Warnings on page 1-1.

GENERAL INFORMATION

The vehicles addressed in this manual are equipped with heavy-duty transaxles. The transaxle utilizes internal gearing to change vehicle direction. Because the transaxle is used to reverse vehicle direction, the engine, drive clutch, belt, and driven clutch rotate in the same direction; therefore, the engine and clutches are not subjected to reversing loads. This reduces maintenance requirements on the engine and clutches. With the transaxle, power is transferred from the engine through the drive clutch, the drive belt, the driven clutch, and then through the transaxle to the wheels.

SHIFTER LEVER

A shifter lever, connected to a shifter arm, is used to change the gears to one of three shift positions: FORWARD (F), NEUTRAL (N), or REVERSE (R). Bring the vehicle to a complete stop before changing FORWARD or REVERSE direction.

NEUTRAL LOCKOUT

For the convenience of the trained technician, there is a neutral lockout switch located on the seat support panel under the seat (**Figure 26-1, Page 26-1**). The neutral lockout switch has two positions, MAINTENANCE and OPERATE, which are clearly marked.

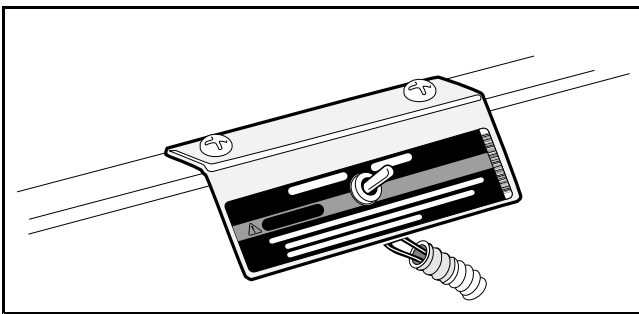

81

Figure 26-1 MAINTENANCE/OPERATE Switch**Pedal-Start Vehicles**

During normal vehicle operation, the neutral lockout switch in the OPERATE position prevents the engine from running when the Forward/Reverse handle is in the NEUTRAL position. If a vehicle is started in FORWARD or REVERSE and then shifted to NEUTRAL, the engine will stop running.

When the switch is in the MAINTENANCE position, it will allow the technician to run the engine in the NEUTRAL position to perform certain maintenance and/or repair functions. With the switch in this position, the vehicle will not operate if the Forward/Reverse handle is placed in either the FORWARD or REVERSE position. **See following WARNING and NOTE.**

⚠ WARNING

- With the switch in the **MAINTENANCE** position and the engine running, the vehicle may move suddenly if the Forward/Reverse handle is shifted or accidentally bumped. To prevent this, chock the front and rear wheels and firmly set the park brake before servicing or leaving the vehicle.

NOTE: Be sure to return the switch to the **OPERATE** position after servicing the vehicle, or it will not run with the Forward/Reverse handle in either the **FORWARD** or **REVERSE** position.

Key-Start Vehicles

During normal vehicle operation, the neutral lockout switch in the **OPERATE** position allows the engine to start only when the Forward/Reverse handle is in the **NEUTRAL** position. In addition, it allows the engine to run and increase RPM's with the Forward/Reverse handle in any position.

With the switch in the **MAINTENANCE** position, it allows the technician to start, run, and increase the engine RPM's only in the **NEUTRAL** position to perform certain maintenance and/or repair functions. With the switch in this position, the engine will shut off if the Forward/Reverse handle is placed in either the **FORWARD** or **REVERSE** position. **See preceding WARNING and NOTE.**

GOVERNOR SYSTEM

The governor system regulates vehicle ground speed. It is mounted inside the transaxle and is driven by transaxle gears. If any of the governor linkages are removed in order to service other components, readjustment of the governor linkage is required. **See Governor Cable Installation and Adjustment on page 23-9.**

TRANSAXLE SERVICE

The transaxle is extremely durable and should require very little service under normal operating conditions. The only service required is to maintain proper lubricant level. **See Lubrication on page 26-2.** Under normal operating conditions, adjustment to the system should not be required.

LUBRICATION

There are two oil port plugs located on the right (driven clutch) side of the transaxle (**Figure 26-2, Page 26-3**). When the vehicle is on a level surface, use the upper plug as a lubricant level indicator. Lubricant level should be even with the bottom of level indicator hole. Use the lower plug for draining. **See following NOTE.**

NOTE: Observe the following for transaxles equipped with a limited-slip differential:

- Uses a magnetic drain plug.
- Unlike most limited-slip differentials, this unit **does not** use a friction modifier added to the gear oil.

Oil Change – Transaxle

1. When draining transaxle oil, remove both plugs to allow the oil to drain faster.
2. Clean and reinstall the drain plug and gasket before filling the transaxle with new lubricant. Tighten drain plug to 17 ft·lb (23 N·m).

3. Use a funnel when filling the transaxle through the lubricant level indicator hole. Fill with 67.6 fl-oz (2 L) 80-90 WT. API class GL or 80-90 WT. AGMA class 5 EP gear lubricant (or until lubricant begins to run out of the level indicator hole).
4. Install upper plug and gasket and tighten to 17 ft-lb (23 N·m).

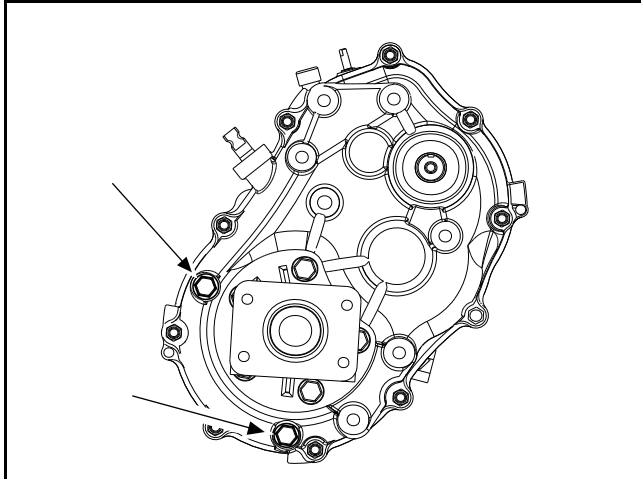

3055

Figure 26-2 Lubricant Level Plug and Drain Plug

TOOLS REQUIRED FOR THIS SECTION

Hydraulic floor jack (or chain hoist)	Torque wrench, 3/8-in. drive	1/2-in. combination wrench
Jack stands (2) (one ton capacity)	3/8-in. socket, 3/8-in. drive	9/16-in. combination wrench
Standard slip joint pliers	7/16-in. socket, 3/8-in. drive	Small flat blade screwdriver
External snap ring pliers (.0047- in. tip)	1/2-in. socket, 3/8-in. drive	Medium flat blade screwdrivers (2)
90° Internal snap ring pliers (0.090-in. tip)	9/16-in. socket, 3/8-in. drive	No. 2 phillips-head screwdriver
16-in. rolling head prybar	5/8-in. socket, 3/8-in. drive	1/4-in. nut driver
Plastic or rubber mallet	Axle seal tool (CC P/N 1014162)	5/16-in. nut driver
Ratchet wrench, 3/8-in. drive	7/16-in. combination wrench	

REAR HUBS

REAR HUB REMOVAL

1. Turn the key switch to the OFF position and remove the key, and place the Forward/Reverse handle in the NEUTRAL position.
2. Disconnect battery and spark plug wire(s). **See Disconnecting the Battery-Gasoline Vehicles on page 1-5.**
3. Place chocks at the front wheels and loosen lug nuts on both rear wheels.
4. Remove the rubber dust cap (1).
5. Remove and discard the cotter pin (2) (**Figure 26-3, Page 26-4**).
6. Remove nut locking cap (3) and loosen the hub nut (4) on the axle shaft.
7. Lift and support the rear of vehicle.
8. Remove the lug nuts and wheel.
9. Slide brake drum off hub.
10. Remove hub nut (4) and large flat washer (5) and pull hub (6) off axle shaft. **See following NOTE.**

NOTE: If the hub (6) does not slide easily off the axle shaft, use a two or four-jaw wheel puller to remove the hub.

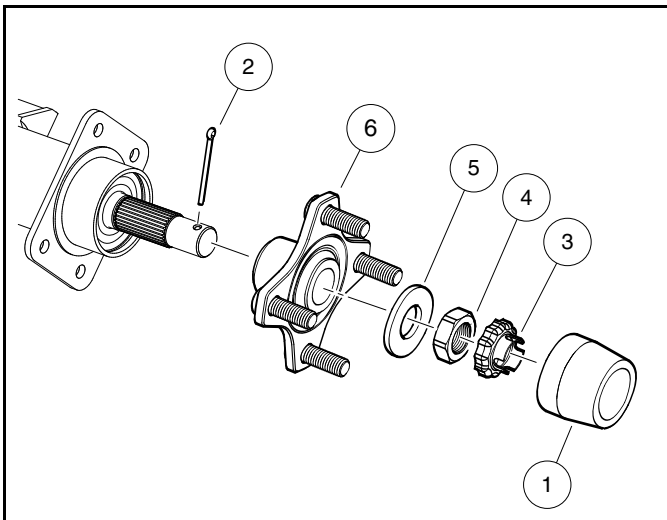

3056

Figure 26-3 Rear Hub Exploded View

REAR HUB INSTALLATION

1. Inspect brake shoes for wear and replace if necessary. **See Wheel Brake Assemblies section.**

NOTE: If brake shoes are replaced on one side, replace the opposite side also.

2. Clean the splines and threaded portion of the axle shaft.
3. Apply anti-seize compound to both the axle shaft splines and hub (6) splines. **See following CAUTION.**

CAUTION

- Do not allow anti-seize compound to contact the brake drum or shoes.
4. Slide hub (6) onto axle shaft (**Figure 26-3, Page 26-4**).
 5. Install the large flat washer (5) onto the threaded portion of the axle.
 6. Install hub nut (4) and advance the nut to the large flat washer.
 7. Install brake drum onto hub.
 8. Install the tire and wheel and finger-tighten the lug nuts.
 9. Lower the rear of the vehicle.
 10. Tighten the hub nut (4) to 147 ft·lb (200 N·m) initially. If possible, position the locking cap (3) on hub nut (4) and install new cotter pin (2). If necessary, tighten hub nut (4) further (177 ft·lb (240 N·m) max.) until the locking cap (3) and new cotter pin (2) can be installed.
 11. Deform cotter pin (2) as shown (**Figure 26-4, Page 26-5**). Either way is acceptable. No part of the cotter pin (2) should protrude beyond the perimeter of the locking cap (3).
 12. Install rubber dust cap (1).
 13. Tighten lug nuts to 65 ft·lb (88 N·m) using a crisscross pattern.
 14. Connect battery and spark plug wire(s). **See Connecting the Battery-Gasoline Vehicles on page 1-5.**

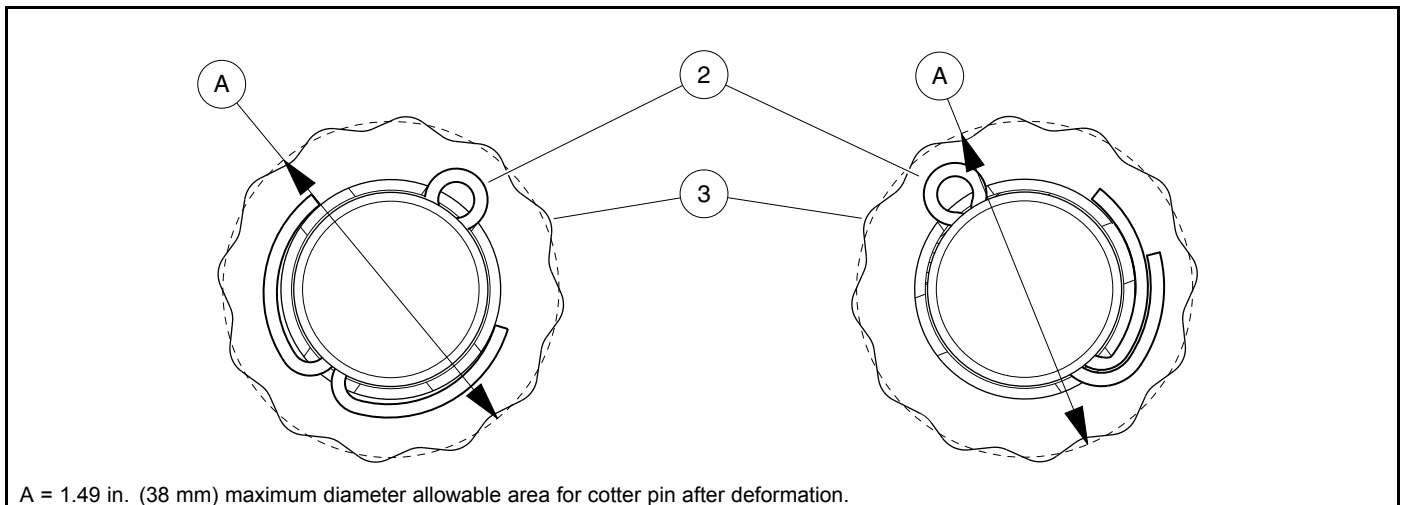

3057

Figure 26-4 Cotter Pin Deformation

AXLE TUBES, AXLE SHAFTS AND WHEEL BEARINGS

Removal of the transaxle is not required for servicing or replacing axle shafts, axle bearings, or axle shaft oil seals. If the transaxle is to be removed from the vehicle, do not remove the wheels, axle shafts, or axle tubes first. Instructions for removing the transaxle from the vehicle begin on page 26-9.

NOTE: The axle shaft oil seals (7) are located in the transaxle gearcase (4), not the axle tubes (2) (Figure 26-5, Page 26-6). The axle tubes must be removed in order to replace these oil seals.

AXLE TUBE AND AXLE SHAFT REMOVAL

See General Warnings, Section 1, Page 1-1.

The transaxle has two axle shafts. If only a tube or shaft is to be serviced, it can be done one side at a time without removing the transaxle.

1. Clean debris from drain plug and area around it at the bottom of the transaxle. Drain oil. Install plug after draining.
2. If removing entire transaxle from vehicle, remove the transaxle and clean it in preparation for disassembly. **See Transaxle Removal on page 26-9. See following NOTE.**

NOTE: After cleaning, move transaxle to a clean location before disassembly.

3. If removing only one axle tube or shaft from vehicle, clean that tube and hub in preparation for disassembly.
4. Remove hub. **See Rear Hub Removal on page 26-4.**
5. Remove the five flange-head bolts (1) securing axle tube (2) to transaxle (Figure 26-5, Page 26-6).
6. Avoiding damage caused by dragging splines across lip of oil seal (7) in transaxle gearcase, carefully pull axle tube (2) and shaft (3) from transaxle.

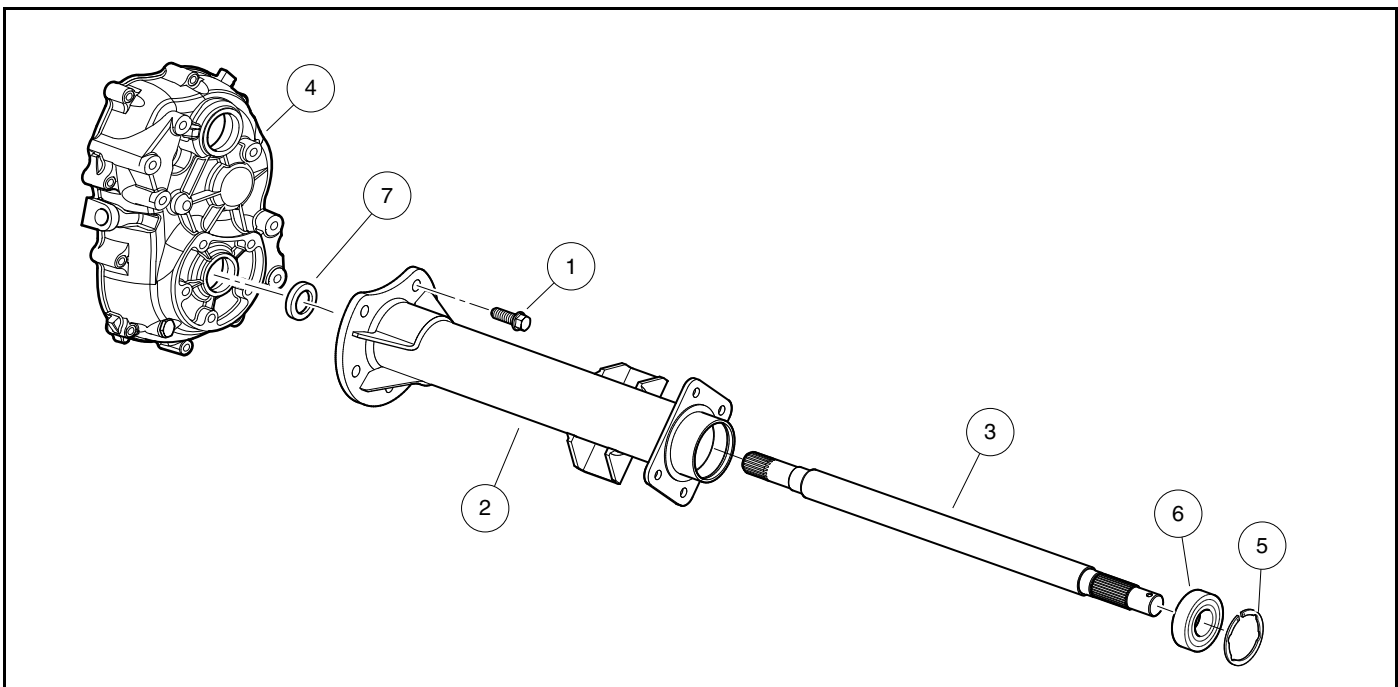

3058

Figure 26-5 Axle Tube, Shaft, Bearing and Oil Seal

AXLE TUBE AND AXLE SHAFT INSTALLATION

1. Clean mating surfaces of axle tube (2) flange and transaxle gearcase (4). Also clean the threads of the five axle tube mounting holes in the gearcase. **See following CAUTION.**

CAUTION

- **If necessary, clean each mounting hole with a thread tap (M10 x 1.25 pitch) before installing flange bolts.**
2. Clean and lubricate the oil seal (7) in the transaxle gearcase (4) with oil (**Figure 26-5, Page 26-6**).
 3. Clean inner end of axle shaft (3). Avoiding damage caused by dragging splines across lip of oil seal (7) in transaxle gearcase (4), carefully install axle shaft (3) and tube (2). **See following NOTE.**

NOTE: *It may be necessary to rotate each shaft (3) slightly to engage the splines in the differential.*

4. Secure axle tube (2) to gearcase (4) with flange bolts (1). Use a crisscross pattern to tighten flange bolts to 28 ft·lb (38 N·m).
5. Install hub. **See Rear Hub Installation on page 26-4.**
6. If entire transaxle was removed from vehicle, install transaxle. **See Transaxle Installation on page 26-13.**
7. Refill transaxle with appropriate type and volume of oil. **See Oil Change – Transaxle on page 26-2.**

REAR WHEEL BEARING REMOVAL

1. Remove hub. **See Rear Hub Removal on page 26-4.**
2. Remove axle tube (2) from transaxle. **See Axle Tube and Axle Shaft Removal on page 26-6.**
3. Remove the snap ring (5) that is in front of the bearing (6) and discard (**Figure 26-5, Page 26-6**).
4. Drive axle shaft (3) and bearing (6) from outer end of axle tube (2) as an assembly.
5. Use a puller to remove bearing (6) from axle shaft (3). **See following CAUTION.**

CAUTION

- **To prevent damaging the threads on end of axle shaft (3), install hub nut to cover initial threads prior to using puller.**

REAR WHEEL BEARING INSTALLATION

1. Press new bearing (6) onto axle shaft (3) until fully seated.
2. Clean inside axle tube (2) where new bearing (6) will sit and lightly lubricate the bore (**Figure 26-5, Page 26-6**).
3. Using an appropriate sized bearing driver that fits the outer race, drive in bearing/shaft assembly (3 and 6) until fully seated in tube (2).
4. Install new snap ring (5).
5. Install axle tube (2). **See Axle Tube and Axle Shaft Installation on page 26-7.**
6. Install hub. **See Rear Hub Installation on page 26-4.**

AXLE SHAFT OIL SEAL REMOVAL

The rear axle tubes (2) must be unbolted from the transaxle to replace oil seals (7) (**Figure 26-5, Page 26-6**).

1. Clean debris from drain plug and area around it at the bottom of the transaxle. Drain oil. Install plug after draining.

2. Remove axle tube (2) from gearcase (4) (**Figure 26-5, Page 26-6**). See **Axle Tube and Axle Shaft Removal on page 26-6**.
3. Pull oil seal (7) from gearcase (4).

AXLE SHAFT OIL SEAL INSTALLATION

1. Clean bore in gearcase (4) where new oil seal (7) will sit (**Figure 26-5, Page 26-6**).
2. Using an appropriate sized seal driver, drive in new oil seal (7) until 0.0393 in. (1 mm) below surface, not fully seated.
3. Clean end of axle shaft (3) and carefully install axle tube (2) to avoid damaging new oil seal (7) with splines of axle shaft. See **Axle Tube and Axle Shaft Installation on page 26-7**.
4. Refill transaxle with appropriate type and volume of oil. See **Oil Change – Transaxle on page 26-2**.

TRANSAXLE REMOVAL

See General Warnings on page 1-1.

1. Turn the key switch to the OFF position and remove the key, and place the Forward/Reverse handle in the NEUTRAL position.
2. Disconnect battery and spark plug wire(s). **See Disconnecting the Battery-Gasoline Vehicles on page 1-5.**
3. Place chocks at the front wheels and loosen lug nuts on both rear wheels.
4. Disconnect air intake hose, vent hose, and fuel line from throttle body and accelerator cable from electrical component box. **See Fuel System: Gasoline Vehicles, Section 23, Page 23-1.**
5. Disconnect gray 18-pin connector from ECU.
6. Disconnect braided ground cable from engine (**Figure 18-8, Page 18-21**).
7. **Pedal-Start Vehicles Only:** Disconnect 3-wire plug from limit switch on transaxle.
8. Disconnect three wires of main wire harness from starter/generator (**Figure 20-14, Page 20-13**).
9. Loosen jam nuts (1) securing shifter cable (2) to FNR/accelerator cable mounting bracket. Then, remove bowtie clip (3) to disconnect shifter cable end (4) from transaxle shift lever (5) and set shifter cable (2) aside (**Figure 26-14, Page 26-14**).
10. Remove bolts (1) securing governor cable bracket (2) and FNR/accelerator cable bracket (3) to transaxle (**Figure 26-6, Page 26-9**). Do not disconnect cables (4 and 5).
11. Unhook governor cable (4) and accelerator cable (5) from the governor arm (7).

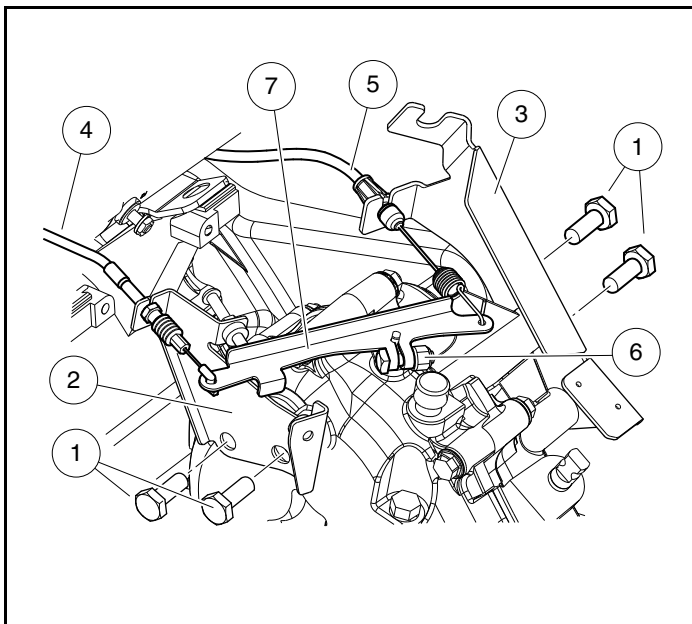

3059

Figure 26-6 Governor Arm, Cable and Brackets

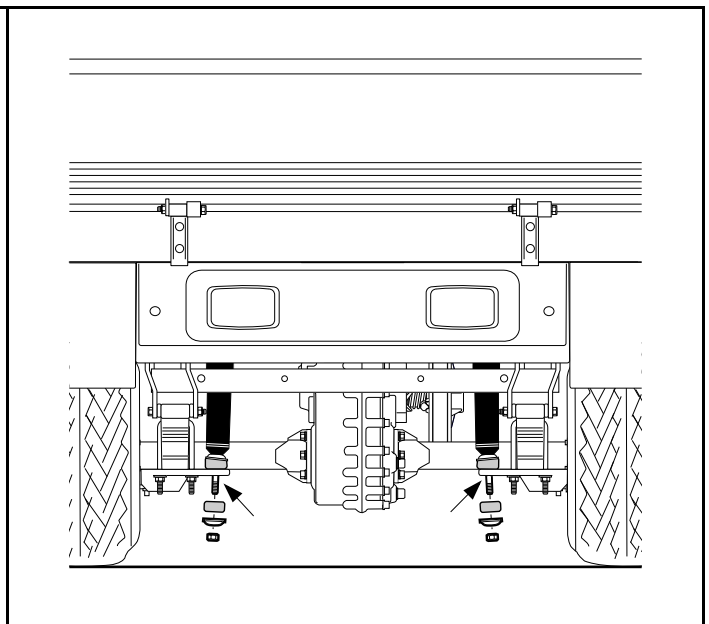

3060

Figure 26-7 Disconnect Shock Absorbers

12. Disconnect brake cables from brake assemblies. **See Wheel Brake Assemblies section.**
13. Remove lower shock mounting hardware from both rear shocks (**Figure 26-7, Page 26-9**).

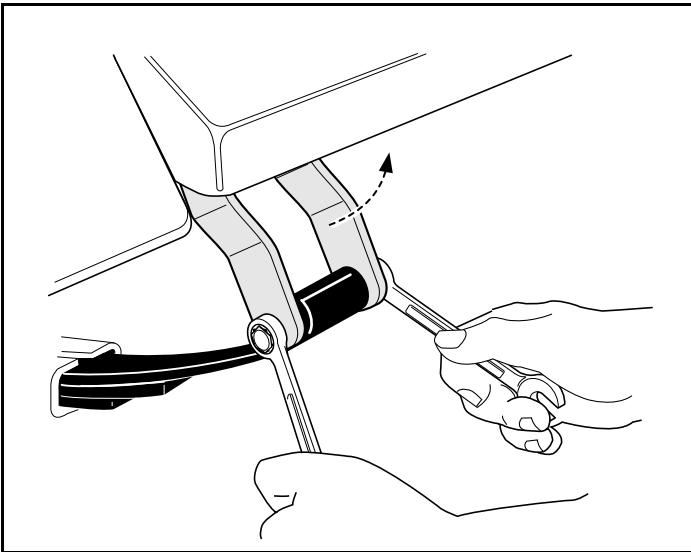

838

Figure 26-8 Disconnect Rear Shackles

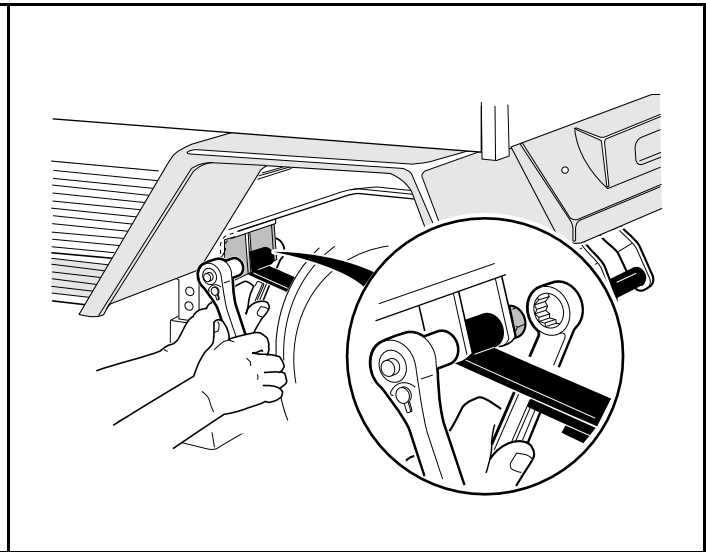

839

Figure 26-9 Disconnect Front of Leaf Spring

14. Position floor jack under rear crossmember of chassis or trailer hitch mount (if equipped) (**Figure 26-10, Page 26-10**). See **WARNING** "Lift only one end of the vehicle..." in **General Warnings** on page 1-1.
15. Raise vehicle just enough to relieve weight on leaf springs, then remove bolts securing leaf springs to shackles (**Figure 26-8, Page 26-10**).
16. Remove bolts securing front of leaf springs (**Figure 26-9, Page 26-10**).

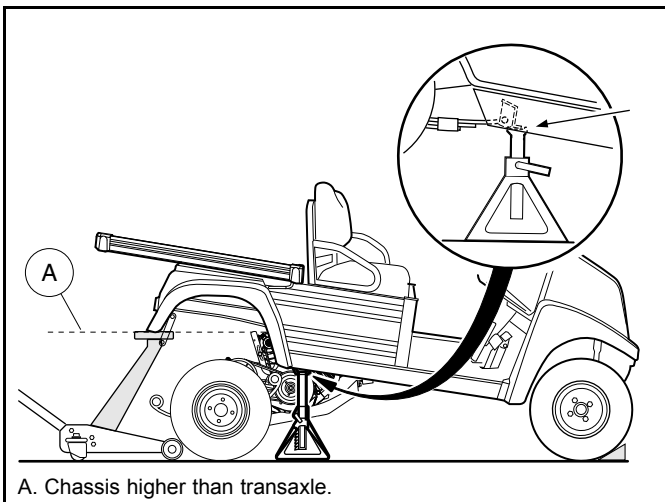

3061

Figure 26-10 Raise Vehicle and Support On Jack Stands

17. Continue raising vehicle until chassis is higher than the top of the transaxle (i.e. enough to allow powertrain to be rolled out from under vehicle) (**Figure 26-10, Page 26-10**). Position jack stands, adjusted to support the vehicle at this height, under the frame crossmember between the leaf spring mounts and side stringers, just forward of each rear wheel. Lower the floor jack to allow the jack stands to support the vehicle.
18. Remove floor jack from beneath vehicle.
19. Grasp ends of leaf springs at rear of vehicle and carefully pull the powertrain until snubber at front of engine pan is free of the chassis. Gently lower front of powertrain to the floor (**Figure 26-11, Page 26-11**). The powertrain should be completely disconnected from vehicle and resting on floor.

20. Roll powertrain out from under vehicle.
21. Place blocks under the engine pan so they will completely support the engine and keep it **level to the floor** (**Figure 26-11, Page 26-11**). See following **NOTE**.

NOTE: Place the blocks so they will support the engine when the transaxle is detached and moved away from the powertrain.

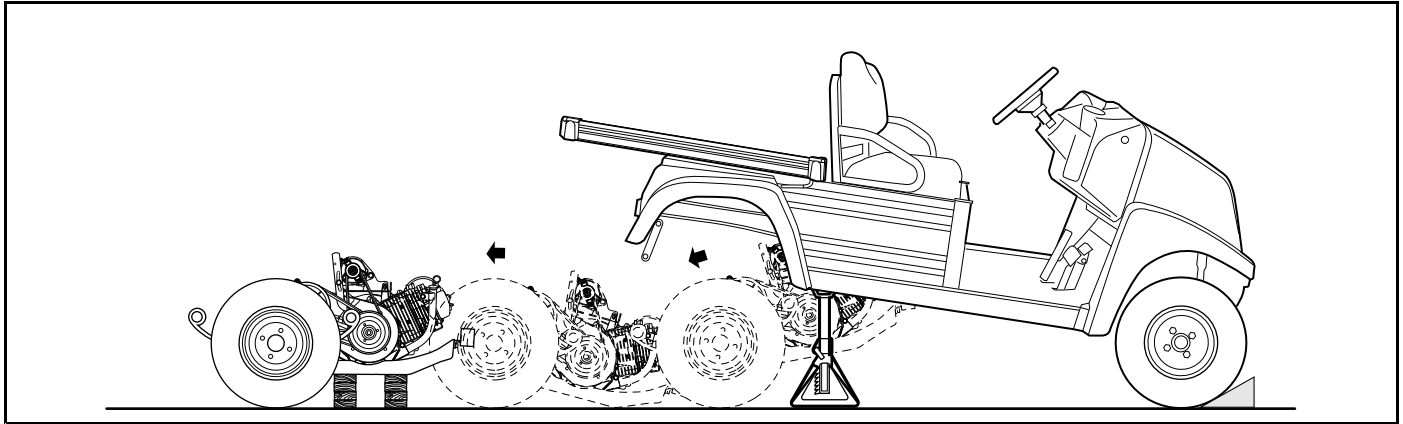

3062

Figure 26-11 Remove Powertrain and Place Wood Blocks Under Engine Pan

22. Remove oil drain plug and drain all oil from transaxle. Dispose of gear oil properly.
23. Remove driven clutch. See **Driven Clutch Removal, Section 25, Page 25-13**.
24. Remove eight bolts (1) total that secure transaxle to powertrain (**Figure 26-12, Page 26-12**) at the following locations:
 - Four bolts (1) at engine pan (2).
 - Two bolts (1) at clutch plate (3).
 - Two bolts (1) at muffler bracket.
25. Roll transaxle from engine pan (2). See following **NOTE**.

NOTE: The transaxle weighs approximately 58 lb (26.2 kg).

26. If replacing transaxle, remove leaf springs, wheels, hubs and brake assemblies and retain for installation on new transaxle. See **Rear Suspension section**. See **Wheel Brake Assemblies section**.

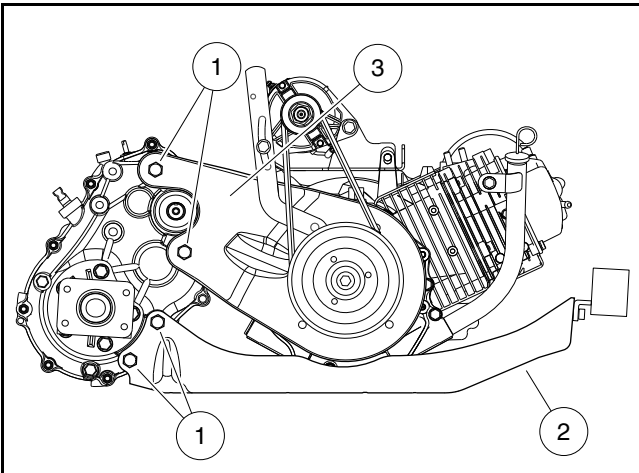

3063

Figure 26-12 Transaxle Mounting Bolts

TRANSAXLE INSTALLATION

See General Warnings on page 1-1.

1. Installation is reverse of removal procedure. When attaching transaxle to powertrain, initially install the eight bolts (1) finger-tight (**Figure 26-12, Page 26-12**). Then, tighten fasteners in the following order:
 - 1.1. Tighten the two bolts (1) at clutch plate (3) to 50 ft·lb (68 N·m).
 - 1.2. Tighten the four bolts (1) at engine pan (2) to 50 ft·lb (68 N·m).
 - 1.3. Tighten the two bolts (1) at muffler bracket to 50 ft·lb (68 N·m).
 - 1.4. Tighten the governor cable bracket (2) and FNR/accelerator cable bracket (2) bolts to 50 ft·lb (68 N·m) (**Figure 26-6, Page 26-9**).
 - 1.5. Tighten leaf spring hardware to 19 ft·lb (26 N·m) at chassis and shackle. **See Rear Suspension section.**
 - 1.6. Tighten lower nuts of shock absorbers until cushions expand to be the same diameter as the mounting washers.
 - 1.7. Tighten transaxle drain plug to 17 ft·lb (23.5 N·m).
2. Fill transaxle with appropriate type and volume of oil. **See Oil Change – Transaxle on page 26-2.**
3. Ensure that all wires and cables are secured properly with wire ties. **See following WARNING.**

▲ WARNING

- **If wires and cables are removed or replaced make sure they are properly routed and secured to vehicle frame. Failure to properly route and secure wires and cables could result in vehicle malfunction, property damage or personal injury.**
4. Connect battery and spark plug wire(s). **See Connecting the Battery-Gasoline Vehicles on page 1-5.**
 5. Check governor adjustment and correct if necessary. **See Governor Cable Installation and Adjustment, Section 23, Page 23-9.**
 6. Check engine RPM setting. Adjust if necessary. **See Engine RPM Adjustment, Section 23, Page 23-13.**

SHIFTER CABLE

See General Warnings on page 1-1.

If the Forward/Reverse shifter cable is damaged in any way, it must be replaced.

SHIFTER CABLE REMOVAL

NOTE: Before removing cable, note cable routing and positions of wire ties or other devices securing the cable to the vehicle. When installed, cable must be routed and secured as it was originally.

1. Turn the key switch to the OFF position and remove the key. Place the Forward/Reverse handle in the NEUTRAL position and chock the wheels.
2. Disconnect battery and spark plug wire(s). **See Disconnecting the Battery-Gasoline Vehicles on page 1-5.**
3. Push the cable end socket (1) off the stud (3) on the Forward/Reverse shifter handle (**Figure 26-13, Page 26-14**).
4. Press in tangs (4) anchoring shifter cable (2) to chassis and push out of mounting hole.
5. Loosen jam nuts (1) securing shifter cable (2) to FNR/accelerator cable bracket (3) (**Figure 26-14, Page 26-14**). Then, remove bowtie clip (3) to disconnect shifter cable end (4) from transaxle shift lever (5).

6. Cut wire ties securing shifter cable to chassis.
7. Make note of cable routing, then remove shifter cable from vehicle.

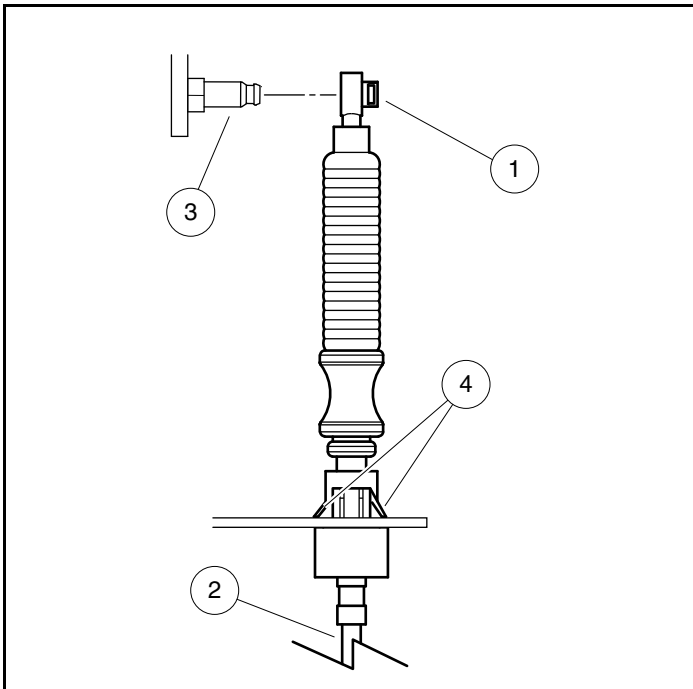

3064

Figure 26-13 Shifter Cable at FNR Handle

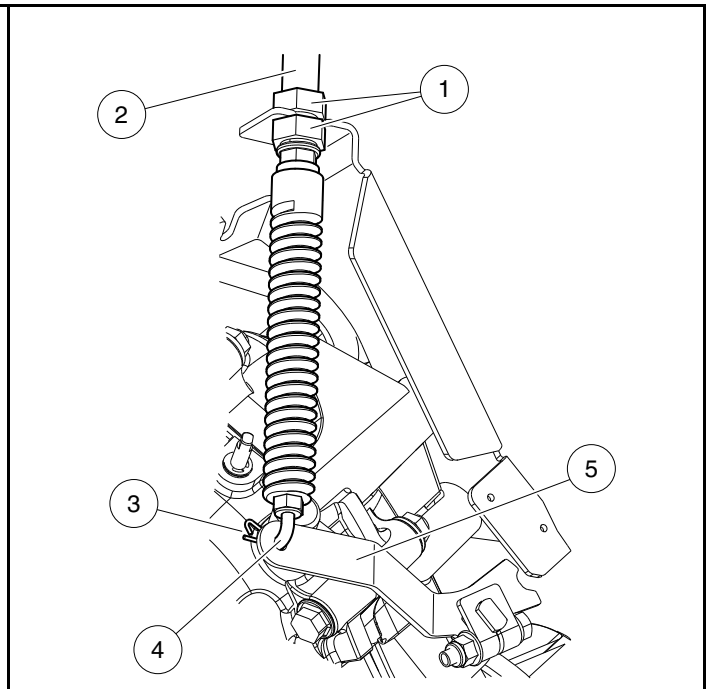

3065

Figure 26-14 Shifter Cable at Transaxle

SHIFTER CABLE INSTALLATION

1. Install shifter cable (2), routing it exactly as it was originally, from instrument panel to transaxle.
2. Place rear of cable (2) in FNR/accelerator cable bracket with a jam nut (1) on each side of bracket (**Figure 26-14, Page 26-14**). Tighten jam nuts (1) to 22 ft·lb (29.8 N·m).
3. Hook shifter cable end (4) into transaxle shift lever (5) and secure with bowtie clip (3).
4. Feed front of cable (2) through its mounting hole and push the plastic anchor into hole until tangs (4) snap into place (**Figure 26-13, Page 26-14**).
5. Snap cable end socket (1) onto stud (3) of Forward/Reverse shifter handle.
6. Secure shifter cable along chassis with wire ties.
7. Connect battery and spark plug wire(s). **See Connecting the Battery-Gasoline Vehicles on page 1-5.**

SHIFTER CABLE ADJUSTMENT

Cable is properly adjusted when both the Forward/Reverse handle at instrument panel and shift lever on transaxle are in the NEUTRAL position at the same time.

To adjust, the jam nuts (6) at the FNR/accelerator cable bracket must be loosened and moved forward or backward as required (**Figure 26-14, Page 26-14**). Tighten jam nuts (6) to 22 ft·lb (29.8 N·m).

A

- AC power and circuit
 - testing (QuiQ charger) 15-12
- accelerator
 - cable
 - installation 23-11
 - removal 23-11
 - pedal (electric)
 - height adjustment..... 5-18
 - installation 5-10
 - removal 5-7
 - pedal (gas)
 - height adjustment..... 5-13
 - installation 5-6
 - removal 5-5
 - pedal limit switch
 - testing 18-26
 - rod
 - installation and adjustment 23-7
 - removal 23-7
- accessories
 - switched power connection 12-1
- air cleaner
 - installation 23-15
 - removal 23-15
- air filter..... 23-15
 - replacement 23-15
- air intake system 23-14
- algorithm
 - battery charger algorithms 15-2
 - change the algorithm 15-3
 - how to identify 15-2
- armature
 - see starter/generator 20-1
- armature, motor
 - see motor, armature 16-7
- axle shaft, rear
 - installation 26-7
 - removal 26-6

B

- batteries..... 14-1
 - care..... 14-6
 - deep discharge 14-14
 - electrolyte
 - adding water (mineral content)..... 14-6
 - level 14-10
 - excessive early discharging 14-14
 - fleet rotation 14-13
 - replacement 14-5
 - see also battery charger 14-1
 - self-discharge 14-10
 - storage 14-13
 - testing 14-3
 - basics 14-2
 - voltage test..... 12-15

- voltage test (under load)..... 12-17
 - vibration damage..... 14-11
- battery
 - installation 20-35
 - storage 20-36
 - testing 18-17
 - testing under load..... 18-17, 18-37
 - voltage test 18-17
- bearing, axle
 - see transaxle, type g, axle bearing 17-4
- bearing, motor
 - see motor, bearing..... 16-9
- bed, tilt
 - see tilt bed 4-13
- belt, drive
 - see drive belt 25-3
- body, front
 - repair..... 4-2
- body, rear
 - repair..... 4-2
- brake, park
 - see park brake 5-4
- brakes
 - adjustment..... 6-6
 - cable
 - installation 6-15
 - removal 6-15
 - cleaning assembly..... 6-3
 - cluster
 - installation 6-13
 - removal 6-13
 - pedal
 - height adjustment (electric)..... 5-16
 - height adjustment (gas) 5-10
 - installation 5-1
 - removal 5-1
 - shoe
 - installation 6-5
 - removal 6-1
- braking, motor
 - see regenerative braking 12-2
- braking, regenerative
 - see regenerative braking 12-2
- bumper
 - installation 4-9
 - removal 4-9

C

- carburetor
 - closed throttle or idle adjustment 23-12
- CAUTION
 - definition of 1-1
- CDT
 - amp hours 11-9
 - anti-tamper speed 11-8
 - audible charging indicator 11-9
 - battery type..... 11-8

INDEX

- code A 11-9
 - code B 11-9
 - code C 11-9
 - connection tests 11-28
 - control mode 11-8
 - deterrent demo speed 11-8
 - diagnostics 11-1
 - diagnostics menu 11-17
 - fault history folder 11-17
 - favorites 11-24
 - general info 11-2
 - handheld programmer 11-2
 - handset cord 11-28
 - handset cord adaptor 11-29
 - HHP settings 11-25
 - introductory display 11-3
 - M1/M2 Fast Accel 11-6
 - M1/M2 Pedal Up 11-6
 - M1/M2 Speed 11-6
 - M1/M2 Speed Cal 11-7
 - monitor menu 11-10
 - parameters menu 11-5
 - plot & log 11-26
 - plug into vehicle 11-2
 - ports 11-29
 - present errors folder 11-17
 - programming menu 11-24
 - quick reference guide – IQ Plus with Quiq 11-4
 - S/N ASCII letter 1 11-9
 - S/N ASCII letter 2 11-9
 - system info menu 11-5
 - troubleshooting 11-27
 - vehicle date of manufacture 11-10
 - vehicle decal 11-10
 - vehicle s/n 11-10
 - walkaway deterrent 11-8
 - CDT General Info 15-1
 - charge indicator light
 - installation 13-11
 - removal 13-11
 - testing 12-42
 - charging diode
 - installation 21-5
 - removal 21-4
 - testing 19-10
 - circuit breaker
 - installation 13-4
 - removal 13-4
 - circuit breaker testing 12-20
 - cleaning
 - brake assembly 6-3
 - vehicle body 4-1
 - clutch (torque converter) troubleshooting 25-1
 - clutch, drive
 - see drive clutch 25-4
 - clutch, driven
 - see driven clutch 25-12
 - column, steering
 - see steering column 7-3
 - commutator
 - see starter/generator 20-1
 - connector, 18-pin
 - see test procedures 18-22, 19-6
 - connector, 24-pin
 - see test procedures 12-33
 - connector, 4-pin
 - see test procedures 12-43, 18-44
 - Controller Diagnostic Tool (CDT)
 - diagnostics 11-1
 - cowl
 - installation
 - gas 4-5
 - removal
 - gas 4-5
- ## D
- DANGER
 - definition of 1-1
 - dash panel
 - removal 4-11
 - DC circuit
 - testing 15-12
 - diagram, wiring
 - key-start gasoline vehicle 19-2
 - pedal-start gasoline vehicle 18-8
 - differential
 - see transaxle 26-9
 - diode, solenoid
 - testing 12-25
 - diode, wire harness
 - testing 12-22
 - drive belt
 - inspection 25-3
 - installation 25-3
 - removal 25-3
 - drive clutch
 - assembly 25-10
 - cleaning and inspection 25-6, 25-9
 - disassembly 25-7
 - installation 25-11
 - removal 25-5
 - drive motor
 - see motor 16-1
 - drive unit
 - see transaxle 26-9
 - driven clutch
 - assembly 25-14
 - disassembly 25-13
 - inspection 25-14
 - installation 25-16
 - removal 25-13
- ## E
- ECU

- connector, 18-pin
 see test procedures..... 18-22, 19-6
 installation 20-17
 removal 20-17
 testing 18-22, 19-6
- electric bed lift
 installation 4-19
 removal 4-19
- electric motor
 see motor 16-1
- electrical system 12-1
 engine ignition circuit
 see also ignition coil and ignition testing 18-35
 gasoline vehicle 18-14
 testing circuits 12-14
- engine 22-1
 adjustments and settings 22-2
 breather 22-6
 installation 22-9
 removal 22-8
 rotation 22-1
 RPM adjustment 23-7, 23-13
 spark plug 22-5
 torque specifications 22-2
 valve clearance check and adjustment 22-7
- engine temperature sensor
 testing 18-22, 19-6
- F**
- fender, tailskirt, rear
 removal 4-17
- floor mat
 installation 4-22
 removal 4-22
- flywheel
 installation 22-11
 removal 22-10
- forward/reverse
 cable
 adjustment 26-14
 installation 26-14
 removal 26-13
 handle (lever) 26-1
 switch
 testing 12-24
- Forward/Reverse switch
 installation 13-3
 removal 13-3
- fuel
 relieving pressure 23-2
- fuel filter
 installation 23-24
 removal 23-23
- fuel gauge/hour meter 20-27
 fuel gauge circuit
 testing 18-40
 fuel level sending unit 20-28
- fuel level sending unit testing 18-39
- hour meter circuit
 testing 18-41
 installation 20-28
 removal 20-27
- fuel gauge/hour meter (gasoline vehicles)
 operation 20-27
- fuel injector
 testing 18-22, 19-6
- fuel level sending unit 20-28
- fuel level sending unit testing 18-39
- fuel line 23-16
 installation 23-17
 removal 23-16
- fuel pump module 23-18
 installation 23-18
 removal 23-18
- fuel pump testing 18-38
- fuel tank 23-21
 disposal 23-22
 installation 23-22
 removal 23-21
 storage 23-22
- fuse
 installation 20-21
 removal 20-21
- fuses
 testing 12-19, 18-19
- G**
- generator
 charging diode 19-10
- governor
 governor system 26-2
- governor cable
 installation and adjustment 23-9
 removal 23-9
- grille
 installation 4-7
 removal 4-6
- ground cable
 testing 18-21
- Guardian
 connector, 4-pin
 see test procedures 12-43, 18-44
- H**
- headlight switch
 installation 20-30
 removal 20-30
- headlights
 see also lighting circuit 18-42
 testing 18-42
- high pedal detect 12-2
- hubs

INDEX

hub, rear
 installation 26-4
 removal 26-4

I

ignition
 testing spark 18-34
ignition coil
 installation 22-13
 removal 22-13
 testing 18-35
inspection
 drive clutch 25-6
 drive clutch parts 25-9
 driven clutch 25-14
 front wheel free play 7-21
 motor
 armature ground test 16-7
 armature inspection 16-7
 bearing 16-9
 brush 16-8
 brush spring 16-8
 field windings 16-8
 speed sensor magnet 16-9
 shock absorber 9-1
 spark plug 22-5
 starter/generator
 armature 20-6
 bearing 20-5–20-6
 brush spring 20-2
 brushes 20-2
 commutator 20-7
 field coils 20-9
 transaxle, type g 17-8
instrument panel
 installation 4-10
 removal 4-10

K

key switch
 engine kill circuit
 testing 18-26
 installation 13-1, 20-18, 21-2
 removal 13-1, 20-18, 21-1
 starter circuit testing (pedal-start) 18-25
 starting circuit testing (key-start) 19-7
 testing 12-23
 testing (key-start) 19-7
kill circuit, engine
 testing 18-33
kill limit switch
 installation 20-22
 removal 20-22
kill limit switch, engine
 testing 18-33

L

leaf spring
 see suspension, front and suspension, rear 9-2
light switch
 testing 18-42
low oil warning light
 installation 20-27
 removal 20-27
 testing 18-36
lubrication
 front suspension 7-15
 transaxle, type g 17-1

M

magnet, motor speed sensor
 see motor, speed sensor magnet 16-9
maintenance/operate switch
 testing 18-28, 19-9
MAP sensor
 testing 18-22, 19-6
motor 12-2
 armature
 ground test 16-7
 inspection 16-7
 assembly 16-11
 bearing
 inspection 16-9
 braking
 pedal down motor braking 12-2
 pedal up motor braking 12-2
 brush
 inspection 16-8
 brush spring
 inspection 16-8
 disassembly 16-4
 features 12-1
 field winding inspection 16-8
 general information 16-1
 identification 16-1
 installation 16-13
 motor braking 12-2
 protection circuit 12-2
 reconditioning 16-11
 removal 16-2
 service specifications 16-11
 speed sensor
 testing 12-29
 speed sensor magnet
 inspection 16-9
 testing 12-32
 see test procedures, motor 16-1
 walk away braking 12-2
 motor braking
 see regenerative braking 12-2
 motor controller output regulator (MCOR)
 testing 12-23, 12-27

motor controller output regulator 3 (MCOR)
 installation 13-6
 removal 13-6
 muffler
 installation 24-1
 removal 24-1
 see also exhaust system..... 24-1

N

neutral lockout..... 26-1
 limit switch
 installation 20-19
 removal 20-19
 testing 18-29

O

oil level sensor
 installation 22-12
 removal 22-12
 testing 18-37
 oil seal
 installation 26-8
 removal 26-7

P

park brake
 adjustment (electric) 5-17
 adjustment (gas) 5-12
 installation 5-4
 removal 5-4
 pedal group adjustment
 electric 5-16
 gasoline 5-10
 powertrain
 removal 26-9

R

rack and pinion
 assembly 7-10
 disassembly 7-8
 installation 7-13
 removal 7-7
 rear suspension
 see suspension, rear 9-1
 rear wheel bearing
 see wheel bearing 26-7
 regenerative braking 12-2
 reverse buzzer
 installation 13-7, 20-23
 limit switch
 installation 20-25
 removal 20-25

testing 18-36
 removal 13-7, 20-23
 testing 12-42, 18-36
 RPM adjustment 23-7, 23-13
 Run/Tow switch 12-2
 installation 13-4
 removal 13-4
 testing 12-18

S

safety 1-1
 schematic diagram
 key-start gasoline vehicle 19-2
 pedal-start gasoline vehicle 18-8
 service tools
 torque converter kit 25-1
 transaxle 26-3
 shock absorber
 see suspension, front and suspension, rear 9-1
 shock absorber, front
 installation 7-20
 removal 7-20
 single point watering system (SPWS) 14-11
 solenoid
 installation 13-8, 20-20, 21-3
 removal 13-8, 20-20, 21-3
 testing 12-26, 18-27, 19-8
 solenoid activating coil
 testing 12-25
 spark plug 22-5
 cleaning, inspection and repair 22-5
 gap adjustment 22-6
 installation 22-6
 removal 22-5
 testing 22-6
 specifications, vehicle 2-1
 speed controller
 connector, 24-pin
 see test procedures 12-33
 installation 13-9
 removal 13-9
 speed controller cover
 installation 13-7
 removal 13-7
 starter/generator
 armature
 ground test 20-8
 inspection 20-6
 servicing 20-4
 assembly 20-3, 20-9
 bearing
 cleaning 20-5–20-6
 inspection 20-5–20-6
 removal 20-6
 belt tension adjustment 20-13
 brush spring
 inspection 20-2

INDEX

replacement	20-2
brushes	20-1
inspection	20-2
replacement	20-2
commutator	20-4
armature replacement	20-7
cleaning	20-7
inspection	20-7
disassembly	20-1, 20-4
field coil	
inspection	20-9
removal	20-6
installation	20-12
removal	20-1
rework	20-9
testing	18-30
steering	
adjustment	7-6
rack and pinion	
assembly	7-10
disassembly	7-8
installation	7-13
removal	7-7
steering column	
assembly	7-4
disassembly	7-4
installation	7-5
removal	7-4
steering wheel	
installation	7-2
removal	7-1
suspension, front	
camber adjustment	7-15
components	7-17
delta a-plate, installation	7-20
delta a-plate, removal	7-20
kingpin and steering spindle, installation	7-20
kingpin and steering spindle, removal	7-17
leaf spring, installation	7-17
leaf spring, removal	7-17
shock absorber, installation	7-20
shock absorber, removal	7-20
wheel bearings and hub, inspection	7-21
wheel bearings and hub, installation	7-22
wheel bearings and hub, removal	7-21
lubrication	7-15
toe-in adjustment	7-16
wheel alignment	7-15
suspension, rear	
leaf spring	
installation	9-3
removal	9-2
shock absorber	
inspection and removal	9-1
installation	9-1

T

test procedures, CDT connection	11-28
test procedures, charger	
AC power and continuity test of AC circuit	15-12
DC circuit continuity test	15-12
test procedures, electric vehicle	
15-amp fuse	12-19
24-pin connector	12-33
4-pin connector	12-43
batteries/voltage check	12-15
battery pack voltage (under load)	12-17
charge indicator light	12-42
charger interlock	12-26
circuit breaker	12-20
Forward/Reverse rocker switch	12-24
key switch & MCOR limit switch circuit	12-23
MCOR	12-27
motor, A1 and A2 voltage	12-32
reverse buzzer	12-42
Run/Tow switch	12-18
solenoid	12-26
solenoid activating coil	12-25
solenoid diode	12-25
speed sensor, motor	12-29
walk away braking relay	12-42
wire harness diodes	12-22
test procedures, index of	
key-start gasoline vehicle	19-6
pedal-start gasoline vehicle	18-15
test procedures, key-start gasoline vehicle	
18-pin connector	19-6
charging diode	19-10
ECU	19-6
EFI	19-6
engine temperature sensor	19-6
fuel injector	19-6
key switch	
ON position (key-start)	19-7
START position (key-start)	19-7
maintenance/operate switch	19-9
MAP sensor	19-6
solenoid	19-8
test procedures, motor	
1 internal short circuits	16-1
2 armature circuit open	16-1
3 field circuit open	16-2
armature ground test	16-7
test procedures, pedal-start gasoline vehicle	
18-pin connector	18-22
4-pin connector	18-44
accelerator pedal limit switch	18-26
battery	18-17
battery load test	18-37
ECU	18-22
EFI	18-22
engine temperature sensor	18-22
fuel gauge	18-40
fuel injector	18-22

- fuel level sending unit 18-39
- fuel pump 18-38
- fuses 18-19
- ground cables 18-21
- headlight socket
voltage at 18-42
- hour meter 18-41
- ignition coil 18-35
- ignition spark 18-34
- key switch
starter circuit (pedal-start) 18-25
- key switch (engine kill circuit) 18-26
- kill limit switch 18-33
- light switch 18-42
- low oil warning light 18-36
- maintenance/operate switch 18-28
- MAP sensor 18-22
- neutral lockout limit switch 18-29
- oil level sensor 18-37
- reverse buzzer 18-36
- reverse buzzer limit switch 18-36
- solenoid 18-27
- starter/generator 18-30
- voltage limiter 18-43
- voltage regulator 18-32
- testing
armature ground test (starter/generator) 20-8
- spark plug 22-6
- throttle body 23-1, 23-3
installation 23-4
removal 23-3
- tie rod and drag link
installation 7-14
removal 7-14
- tilt bed
installation 4-13
removal 4-13
- tire
installation 8-3
pressure 8-1
removal 8-2
repair 8-2
- tools
see service tools 26-3
- torque converter
troubleshooting 25-1
- transaxle
installation 26-13
lubrication 26-2
removal 26-9
service 26-2
- transaxle, type g
assembly 17-10
axle bearing 17-4
axle shaft
installation 17-4
removal 17-1
disassembly 17-8
inspection 17-8
- installation 17-12
- lubrication 17-1
- oil seal
installation 17-4
removal 17-1
removal 17-5
- troubleshooting 12-8
CDT handheld programmer 11-27
torque converter 25-1
troubleshooting guide 1 12-9
troubleshooting guide 2 12-12
- troubleshooting guide
gasoline vehicle 18-2
- ## V
- Visage
connector, 4-pin
see test procedures 12-43, 18-44
- voltage limiter
testing 18-43
- voltage regulator
installation 20-16
removal 20-15
testing 18-32
- ## W
- walk away braking 12-2
- walk away braking relay
testing 12-42
- WARNING
definition of 1-1
- water level
see batteries, electrolyte level 14-10
- wheel
installation 8-1
removal 8-1
see also tire 8-3
- wheel bearing
installation 26-7
removal 26-7
- wiring diagram – key-start gasoline vehicle 19-2
- wiring diagram – pedal-start gasoline vehicle 18-8
- wiring diagrams 12-4



Club Car, LLC
P.O. Box 204658
Augusta, GA 30917-4658
USA

Web www.clubcar.com
Phone 1.706.863.3000
1.800.ClubCar
Int'l +1 706.863.3000
Fax 1.706.863.5808