

The word "Pioneer" is written in a large, bold, black, cursive-style font. To its right, the number "1200" is written in a smaller, bold, black, sans-serif font. The text is set against a background of light gray, abstract, flowing shapes that resemble a stylized map or a dynamic graphic element.

Pioneer
1200

The Club Car logo consists of a stylized, black, curved shape resembling a crescent moon or a wing, positioned to the left of the text.

Club CarTM
Performance Utility Vehicles

2001 MAINTENANCE & SERVICE MANUAL
Manual No. 102190012 Edition Code 1000A00000

FOREWORD

Club Car vehicles are designed and built to provide the ultimate in performance efficiency; however, proper maintenance and repair are essential for achieving maximum service life and continued safe and reliable operation.

This manual provides detailed information for the maintenance and repair of the Pioneer 1200 vehicle, and should be thoroughly reviewed prior to servicing the vehicle. The procedures provided herein must be properly implemented, and the DANGER, WARNING, and CAUTION statements must be heeded.

This manual was written for the trained technician who already possesses knowledge and skills in electrical and mechanical repair. *If the technician does not have such knowledge and skills, attempted service or repairs to the vehicle may render the vehicle unsafe.* For this reason, Club Car advises that all repairs and/or service be performed by an authorized Club Car distributor/dealer representative or by a Club Car factory-trained technician.

It is the policy of Club Car, Inc. to assist its distributors and dealers in continually updating their service knowledge and facilities so they can provide prompt and efficient service for vehicle owners. Regional technical representatives, vehicle service seminars, periodic service bulletins, maintenance and service manuals, and other service publications also represent Club Car's continuing commitment to customer support.

This manual covers all aspects of typical vehicle service; unique situations, however, do sometimes occur when servicing a vehicle. If it appears that a service question is not answered in this manual, you may write to us at: Club Car, Inc.; P.O. Box 204658; Augusta, Georgia 30917; Attention: Technical Services, or contact a Club Car Technical Service Representative at (706) 863-3000, ext. 3580.

©2000 Club Car, Inc.

Club Car is a registered trademark of Club Car, Inc.

This manual effective October 2, 2000

WARNING

- **Read Section 1 – Safety before attempting any service on this vehicle.**
- **Before servicing vehicle, read complete section(s) and any referenced information that may be relevant to the service or repair to be performed.**

NOTE: This manual represents the most current information at the time of publication. Club Car, Inc. is continually working to further improve our vehicles and other products. These improvements may affect servicing procedures. Any modification and/or significant change in specifications or procedures will be forwarded to all Club Car dealers and will, when applicable, appear in future editions of this manual.

Damage to a vehicle or component thereof not resulting from a defect or that occurs due to unreasonable or unintended use, overloading, abuse, or neglect (including failure to provide reasonable or necessary maintenance as instructed in the vehicle owner's manual), accident or alteration, including increasing vehicle speed beyond factory specifications or modifications that affect the stability of the vehicle or the operation thereof, will void the warranty.

Club Car, Inc. reserves the right to change specifications and designs at any time without notice and without incurring any obligation or liability whatsoever.

There are no warranties expressed or implied in this manual. See the limited warranty found in the vehicle owner's manual or write to Club Car, Inc., P.O. BOX 204658, Augusta, Georgia 30917-4658 USA, Attention: Warranty Department.

CONTENTS

SECTION 1 – SAFETY

General Warning	1-1
-----------------------	-----

SECTION 2 – VEHICLE SPECIFICATIONS

General Information	2-1
Specifications	2-1

SECTION 3 – GENERAL INFORMATION

Serial Number Identification	3-1
Storage – Gasoline Vehicle	3-1
Preparing the Vehicle for Extended Storage	3-1
Returning the Stored Vehicle to Service	3-2

SECTION 4 – BODY AND TRIM

Cleaning the Vehicle	4-1
Front Body Repair	4-2
Light Scratches, Abrasions and Haze	4-2
Deeper Scratches	4-2
Gouges, Punctures, Tears, Large Scratches, and Abrasions	4-2
Brush Guard	4-2
Brush Guard Removal	4-2
Brush Guard Installation	4-2
Front Body Components	4-3
Dashboard Removal	4-3
Dashboard Installation	4-3
Front Body Removal	4-3
Front Fender Removal	4-5
Front Fender Installation	4-5
Front Body Installation	4-5
Seat	4-5
Seat Removal	4-5
Seat Installation	4-6

Seat Support	4-6
Seat Support Removal	4-6
Seat Support Installation	4-6
Armrest Removal	4-7
Armrest Installation	4-8
Tilt Bed	4-8
Tilt Bed Removal	4-8
Tilt Bed Installation	4-8
Bed Stop Bumper Adjustment	4-8
Rear Fender	4-10
Rear Fender Removal	4-10
Rear Fender Installation	4-10
Tailskirt	4-10
Tailskirt Removal	4-10
Tailskirt Installation	4-10
Receiver Hitch	4-10
Receiver Hitch Removal	4-10
Receiver Hitch Installation	4-12
Floor Mat	4-12
Floor Mat Removal	4-12
Floor Mat Installation	4-12

SECTION 5 – ACCELERATOR AND BRAKE PEDAL ASSEMBLIES

Brake Pedal Adjustment	5-1
Accelerator Pedal Adjustment	5-3
Brake Pedal	5-7
Brake Pedal Removal	5-7
Brake Pedal Installation	5-8
Accelerator Pedal	5-8
Accelerator Pedal Removal	5-8
Accelerator Pedal Installation	5-9

SECTION 6 – HYDRAULIC AND PARK BRAKE SYSTEMS

General Information	6-1
Brake System Inspection	6-2
Brake System Troubleshooting	6-4
Brake Drum Removal	6-7
Front Wheel Brake Drum Removal	6-7
Rear Wheel Brake Drum Removal	6-8
Brake Shoe Removal	6-9

Brake Cluster Assembly Inspection and Cleaning	6-10
Brake Shoe Installation	6-12
Brake Drum Installation	6-14
Front Wheel Brake Drum Installation	6-14
Rear Wheel Brake Drum Installation	6-16
Brake Cluster Replacement	6-17
Front Brake Cluster Removal	6-17
Front Brake Cluster Installation	6-17
Rear Brake Cluster Removal	6-18
Rear Brake Cluster Installation	6-19
Wheel Cylinder Replacement	6-19
Wheel Cylinder Removal	6-20
Wheel Cylinder Installation	6-21
Brake Shoe Adjuster Replacement	6-21
Brake Shoe Adjuster Removal	6-21
Brake Shoe Adjuster Installation	6-22
Hydraulic Line and Hose Replacement	6-24
Front Brake Line Removal	6-24
Front Brake Line Installation	6-24
Front Brake Cluster Hose Removal	6-24
Front Cluster Hose Installation	6-25
Rear Brake Line Removal	6-25
Rear Brake Line Installation	6-25
Rear Brake Cluster Hose Removal	6-26
Rear Cluster Hose Installation	6-26
Master Cylinder and Bell Crank Replacement	6-26
Bell Crank Removal	6-26
Bell Crank Installation	6-28
Master Cylinder Removal	6-28
Master Cylinder Installation	6-28
Bleeding the Hydraulic Brake System	6-29
Purging the Hydraulic System	6-30
Filling the Hydraulic System	6-31
Park Brake System	6-31
Park Brake Cable Removal	6-31
Park Brake Cable Installation	6-33
Park Brake Handle Removal	6-33
Park Brake Handle Installation	6-34
Park Brake Adjustment	6-34

SECTION 7 – STEERING AND FRONT SUSPENSION

General Information	7-1
Steering Wheel	7-1
Steering Wheel Removal	7-1
Steering Wheel Installation	7-3
Steering Column	7-4
Steering Column Removal	7-4
Steering Column Disassembly	7-4
Steering Column Assembly	7-5
Steering Column Installation	7-6
Rack and Pinion	7-6
Rack and Pinion Removal	7-6
Rack and Pinion Disassembly	7-8
Rack and Pinion Assembly	7-10
Rack and Pinion Installation	7-13
Front Suspension	7-13
Lubrication	7-13
Wheel Alignment	7-14
Front Suspension Components	7-16
Kingpin and Steering Spindle Removal	7-16
Kingpin and Steering Spindle Installation	7-17
A-Arm Removal	7-17
A-Arm Installation	7-18
Shock Absorber Removal and Inspection	7-18
Shock Absorber Installation	7-19
Front Wheel Bearings and Hubs	7-20
Front Wheel Free Play Inspection	7-20
Front Wheel Bearings and Hub Removal	7-20
Front Wheel Bearings and Hub Installation	7-20

SECTION 8 – WHEELS AND TIRES

General Information	8-1
Wheels	8-2
Wheel Removal	8-2
Wheel Installation	8-2
Tires	8-3
Tire Removal	8-3
Tire Repair	8-3
Tire Installation	8-3

SECTION 9 – REAR SUSPENSION

General Information	9-1
Shock Absorbers	9-1
Shock Absorber Removal and Inspection	9-1
Shock Absorber Installation	9-3
Multi-Leaf Springs	9-3
Multi-Leaf Spring Removal	9-3
Multi-Leaf Spring Installation	9-4
Snubber	9-5
Snubber Removal	9-5
Snubber Installation	9-5

SECTION 10 – PERIODIC MAINTENANCE

General Information	10-2
Daily Pre-Operation Safety Checklist	10-2
Periodic Service Schedule	10-3
Periodic Lubrication Schedule	10-4
Master Cylinder	10-6
Brake Fluid	10-6
Engine Oil	10-6
Oil Viscosity	10-7
Fueling Instructions	10-7
Battery	10-8

SECTION 11 – TROUBLESHOOTING AND ELECTRICAL SYSTEM

General Information	11-2
Troubleshooting Guide	11-2
Wiring Diagram	11-6
Electrical System	11-8
Electrical Circuits	11-9
Starter Circuit	11-9
Generator Circuit	11-9
Engine Ignition Circuit	11-10
Engine Kill Circuit	11-10
Reverse Buzzer Circuit	11-11
Low Oil Warning Circuit	11-12
Lockout Cam Circuit	11-12
Fuel Gauge and Sending Unit Circuit	11-13
Hour Gauge Circuit	11-14
Lighting Circuit	11-14

Circuit Testing	11-14
Testing the Starter Circuit and Generator Circuit	11-15
Testing the Engine Ignition Circuit	11-16
Testing the Engine Kill Circuit	11-16
Testing the Reverse Buzzer Circuit	11-17
Testing the Low Oil Warning Circuit	11-18
Testing the Lockout Cam Circuit	11-19
Testing the Fuel Gauge and Sending Unit Circuit	11-19
Testing the Lighting Circuit	11-20
Test Procedures	11-20
Index of Test Procedures	11-20

SECTION 12 – ELECTRICAL COMPONENTS

Starter/Generator	12-2
Voltage Regulator	12-13
Diode	12-14
Key Switch	12-15
Solenoid	12-17
Fuse	12-18
Lockout Cam Limit Switch	12-18
Lockout Cam	12-19
Reverse Warning Buzzer	12-20
Reverse Buzzer Limit Switch	12-21
Oil Warning Light	12-22
Fuel/Hour Gauge	12-23
Fuel Level Sending Unit	12-24
RPM Limiter	12-24
Ignition Coil	12-25
Oil Level Sensor	12-28
Headlights	12-29
Headlight Diode	12-30
Light Switch	12-30
Battery	12-31
Ground Straps	12-36

SECTION 13 – FE350 ENGINE

General Information	13-2
Special Engine Service Tools Available from Club Car	13-2
Before Servicing	13-2
Mechanical Systems	13-2
Electrical System	13-4
Lubrication System	13-5
Hydraulic Lifters	13-6
Spark Plug	13-6
Engine Mounting Plate	13-8
Cylinder Head	13-8
General Information	13-8
Cylinder Shroud Removal	13-8
Rocker Arm and Push Rod Removal	13-10
Cylinder Head Removal	13-10
Valve Removal	13-11
Breather Valve (Reed Valve)	13-12
Cylinder Head Cleaning and Inspection	13-12
Valve Guides	13-13
Valve Seats	13-13
Valves	13-16
Rocker Arm and Rocker Shaft inspection	13-18
Push Rod Inspection	13-19
Cylinder Head Installation	13-19
Valve Clearance Check and Adjustment	13-20
Breather Valve (Reed Valve)	13-20
Installation of Remaining Engine Components	13-21
Crankcase	13-23
Engine Removal	13-23
Crankcase Cover Removal	13-24
Oil Level Sensor	13-24
Camshaft and Hydraulic Lifters	13-25
Piston and Connecting Rod	13-27
Cylinder Block	13-30
Ignition Coil and Flywheel	13-31
Oil Pump	13-32
Oil Pressure Relief Valve	13-34

Crankshaft and Counterbalance	13-35
Counterbalance Weight	13-38
Oil Screen	13-40
Ball Bearing	13-41
Oil Seals	13-42
Crankshaft Axial Play Adjustment	13-44
Crankcase Cover Installation	13-47
Engine Assembly	13-48
Service Specifications	13-50
Specifications for Resizing Cylinder Bore	13-51
Torque Specifications	13-51
Adjustments and Settings	13-52

SECTION 14 – FUEL SYSTEM

General Information	14-1
How the Carburetor Works	14-2
Main System	14-2
Slow Speed System	14-2
Choke and Fresh Air System	14-4
Float System	14-4
Carburetor	14-4
Main Jet Elevation/Size Chart	14-5
Changing the Main Jet	14-5
Engine Control Linkage	14-8
General Information	14-8
Accelerator Rod	14-9
Governor Cable	14-10
Accelerator Cable	14-11
Closed Throttle or Idle Adjustment	14-13
Engine RPM Adjustment	14-13
Choke and Air Intake System	14-14
General Information	14-14
Choke Cable Removal	14-14
Choke Cable Installation	14-14
Air Box Removal	14-15
Air Box Installation	14-15
Intake Duct Removal	14-15
Intake Duct Installation	14-16
Intake Duct Repair	14-18
Air Filter	14-18

Fuel Filters	14-19
General Information	14-19
Fuel Filter Removal	14-19
Fuel Filter Installation	14-19
Fuel Pump	14-21
General Information	14-21
Fuel Pump Removal	14-21
Fuel Pump Disassembly	14-21
Fuel Pump Cleaning and Inspection	14-22
Fuel Pump Assembly	14-22
Fuel Pump Installation	14-23
Fuel Tank	14-23
General Information	14-24
Preparation for Extended Storage	14-24
Fuel Tank Removal	14-24
Fuel Tank Disposal	14-25
Fuel Tank Storage	14-25
Fuel Tank Installation	14-25
Fuel Lines	14-27
Fuel Shut-Off Valve	14-28

SECTION 15 – EXHAUST SYSTEM

General Information	15-1
Muffler	15-2
Muffler Removal	15-2
Muffler Installation	15-2

SECTION 16 – UNITIZED TRANSAXLE WITH DIFFERENTIAL LOCK

General Information	16-1
Lubrication	16-3
Axle Shaft	16-3
Axle Shaft and Oil Seal Removal	16-4
Axle Bearing	16-5
Axle Shaft Installation	16-7
Unitized Transaxle Removal	16-7
Unitized Transaxle Disassembly	16-15

Component Disassembly	16-19
Differential Gear Lock Housing Disassembly	16-19
Governor Gear Disassembly	16-21
Differential Gear Case Disassembly	16-22
Shifter Fork Disassembly	16-23
Synchronizer Gear Disassembly	16-23
Intermediate Gear Disassembly	16-24
Idler Shaft Disassembly	16-24
Unitized Transaxle Component Inspection	16-26
Component Assembly	16-26
Idler Shaft Assembly	16-26
Intermediate Gear Assembly	16-26
Synchronizer Gear Assembly	16-26
Shifter Fork Assembly	16-29
Differential Gear Case Assembly	16-29
Governor Gear Assembly	16-31
Differential Gear Lock Housing Assembly	16-31
Unitized Transaxle Assembly	16-32
Unitized Transaxle Installation	16-39
Forward/Reverse (F&R) Shifter Cable	16-47
F&R Shifter Cable Removal	16-47
F&R Shifter Cable Installation	16-47
F&R Shifter Cable Adjustment	16-48
Differential Lock System	16-49
Differential Lock System Inspection	16-49
Differential Lock Cable Removal	16-49
Differential Lock Cable Installation	16-51

SECTION 17 – TORQUE CONVERTER

General Information	17-1
Troubleshooting	17-3
Drive Belt	17-3
Drive Belt Removal	17-3
Drive Belt Installation	17-4
Drive Clutch	17-4
Drive Clutch Removal	17-4
Drive Clutch Cleaning and Inspection	17-5
Drive Clutch Disassembly	17-7
Inspection of Drive Clutch Parts	17-9
Drive Clutch Assembly	17-9
Drive Clutch Installation	17-13

Driven Clutch 17-13
 Driven Clutch Removal 17-13
 Driven Clutch Disassembly 17-13
 Driven Clutch Inspection 17-14
 Driven Clutch Assembly 17-14
 Driven Clutch Installation 17-15

SECTION 1 – SAFETY

To ensure the safety of those servicing Club Car vehicles, and to protect the vehicles from possible damage resulting from improper service or maintenance, the procedures in this manual must be followed. It is important to note that throughout this manual there are statements labeled **DANGER**, **WARNING**, or **CAUTION**. These special statements relate to specific safety issues, and must be read, understood, and heeded before proceeding with procedures. There are statements labeled **NOTE**, which provide other essential service or maintenance information.

⚠ DANGER

- A **DANGER** indicates an immediate hazard that will result in severe personal injury or death.

⚠ WARNING

- A **WARNING** indicates an immediate hazard that could result in severe personal injury or death.

⚠ CAUTION

- A **CAUTION** indicates hazards or unsafe practices that could result in product or property damage or minor personal injury.

GENERAL WARNING

The following safety procedures must be followed whenever the vehicle is being operated, repaired, or serviced. Service technicians should become familiar with these general statements, which can be found throughout this manual. Also, other specific warnings appear throughout this manual and on the vehicle.

⚠ DANGER

- **Battery – Explosive gases! Do not smoke. Keep sparks and flames away from the vehicle and service area. Ventilate when charging or using in an enclosed space. Wear a full face shield and rubber gloves when working on or near batteries.**
- **Battery – Poison! Contains acid! Causes severe burns. Avoid contact with skin, eyes, or clothing. Antidotes:**
 - **External: Flush with water. Call a physician immediately.**
 - **Internal: Drink large quantities of water. Follow with milk of magnesia or vegetable oil. Call a physician immediately.**
 - **Eyes: Flush with water for 15 minutes. Call a physician immediately.**
- **Gasoline – Flammable! Explosive! Do not smoke. Keep sparks and flames away from vehicle and service area. Service only in a well-ventilated area.**
- **Do not operate gasoline vehicle in an enclosed area without proper ventilation. The engine produces carbon monoxide, which is an odorless, deadly poison.**
- **A Club Car vehicle will not provide protection from lightning, flying objects, or other storm related hazards. If caught in a storm while driving a Club Car vehicle, exit the vehicle and seek shelter in accordance with applicable safety guidelines for your location.**

⚠ WARNING

- Only trained technicians should repair or service the vehicle. Anyone doing even simple repairs or service should have knowledge and experience in electrical and mechanical repair.
- Follow the procedures exactly as stated in this manual, and heed all DANGER, WARNING, and CAUTION statements in this manual as well as those affixed to the vehicle.
- Improper use of the vehicle or failure to properly maintain it, could result in decreased vehicle performance or severe personal injury.
- Any modification or change to the vehicle that affects the stability or handling of the vehicle, or increases maximum vehicle speed beyond factory specifications, could result in severe personal injury or death.
- Check the vehicle owner's manual for proper location of all vehicle warning decals and make sure they are in place and are easy to read.
- Wear safety glasses or approved eye protection when servicing the vehicle.
- Do not wear loose clothing. Remove jewelry such as rings, watches, chains, etc. before servicing vehicle.
- Moving parts! Do not attempt to service the vehicle while it is running.
- Hot! Do not attempt to service hot engine or exhaust systems. Failure to heed this warning could result in severe burns.
- Use insulated tools when working near batteries or electrical connections. Use extreme caution to avoid shorting of components or wiring.
- Turn the key switch to OFF and remove key. Chock the wheels, place the Forward/Reverse handle in NEUTRAL, and disconnect battery prior to servicing the vehicle.
- To avoid unintentionally starting the vehicle:
 - Disconnect battery cables, negative cable (–) first (Figure 1-1, Page 1-2).
 - Disconnect the spark plug wire from the spark plug.
- Frame ground – Do not allow tools or other metal objects to contact frame when disconnecting battery cables or other electric wiring. Never allow a positive wire to touch the vehicle frame, engine, or any other metal component.
- Lift only one end of the vehicle at a time. Before lifting, set the park brake when lifting the front of the vehicle, unload the cargo bed and chock the wheels that remain on the floor. Use a suitable lifting device (chain hoist or hydraulic floor jack) with 1000 lb. (454 kg) minimum lifting capacity. Do not use lifting device to hold vehicle in raised position. Use approved jack stands of proper weight capacity to support the vehicle.

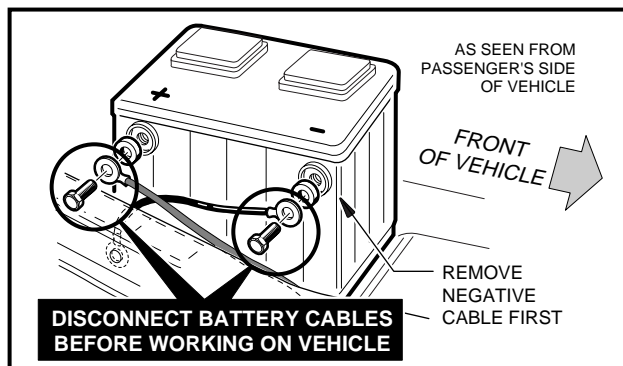

Figure 1-1 Battery

SECTION 2 – VEHICLE SPECIFICATIONS

GENERAL INFORMATION

Club Car, Inc. reserves the right to change specifications and design of the vehicle at any time without notice and without obligation to make these changes on units previously sold.

SPECIFICATIONS	
POWER SOURCE	
Engine: 4 cycle, OHV, 351 cc, 11 hp rated, single cylinder, air cooled, with pressure lubrication system	•
Fuel System: Side draft carburetor with float bowl, fixed jets, fuel filters, and impulse fuel pump	•
Governor: Automatic ground speed sensing, internally geared in unitized transaxle	•
Ignition: Transistor electronic ignition with electronic RPM limiter	•
Transaxle: Fully synchronized forward and reverse with neutral (15:1 forward, 20.6:1 reverse) with differential lock feature	•
Torque Converter: Automatic, variable speed, dry type	•
Electrical System: 12 volt, 500 cca at 0 °F (-17.8 °C), 650 at 32 °F (0 °C), 105-minute reserve capacity and 35-amp charging capacity	•
STEERING/SUSPENSION/BRAKES	
Steering: Self-adjusting rack and pinion	•
Suspension: Front: Independent A-arms with coil-over shocks Rear: Semi-independent rear suspension with multi-leaf springs and dual hydraulic shocks	•
Brakes: Hydraulic brake system – self-adjusting drum brakes on each wheel with separate hand-operated park brake	•
BODY/CHASSIS	
Frame/Chassis: Twin I-Beam welded aluminum	•
Side and Rear Body: All aluminum with a powder-coated steel box bed	•
Front Body: ABS/DR acrylic molded-in color	•
Tires: 23 x 10.50 - 12 tubeless, 4 ply rated load range, front and rear	•
DIMENSIONS/WEIGHT	
Overall Length (box bed configuration)	123.4 in. (313.4 cm)
Overall Width	54 in. (137 cm)
Overall Height (at steering wheel)	51 in. (130 cm)
Wheelbase	80 in. (203 cm)
Ground Clearance: (under differential): (under foot platform):	6.6 in. (17 cm) 11.4 in. (29 cm)
Front Wheel Tread	43 in. (109 cm)
Rear Wheel Tread	43.5 in. (111 cm)
Weight: (dry): (with all-terrain tread): (With turf tread):	1101 lb. (499.9 kg) 1047 lb. (475.4 kg)
Forward Speed:	17-19 mph (27-31 km/h)
Curb Clearance Circle (diameter)	24 ft. 1 in. (734 cm)
Turning Radius (per SAE J 695)	139.6 in. (355 cm)
Intersecting Aisle Clearance	112.2 in. (285 cm)
Floorboard Height	17 in. (43 cm)
Load Bed Height	31.1 in. (79 cm)
Vehicle Specifications continued on next page...	

SPECIFICATIONS	
DIMENSIONS/WEIGHT (Continued)	
Seat Height	35 in. (89 cm)
Load Bed Size (box bed inside dimensions)	48.0 x 49.8 x 10.9 in. (121.9 x 126.4 x 27.6 cm)
Load Bed Size (flat bed dimensions)	46.9 x 48.3 in. (119 x 123 cm)
Vehicle Rated Capacity (level surface only)	1200 lb. (544 kg)
Bed Load Capacity (level surface only)	800 lb. (363 kg)
Standard Seating Capacity	2
LIQUID CAPACITIES	
Engine Crankcase without filter	32 oz. (.95 liters)
Engine Crankcase with filter	38 oz. (1.12 liters)
Unitized Transaxle	31 oz. (.92 liters)
Fuel Tank	7 gal. (26.5 liters)
Master Cylinder	8 oz. (240 ml)
TIRE PRESSURE	
All Terrain Tread	Front: 7-11 psi (48-76 kPa) Rear: 14-18 psi (97-124 kPa)
Turf Tread	Front: 12-16 psi (83-110 kPa) Rear: 16-20 psi (110-138 kPa)
Traks Max II Tread	Front: 14-16 psi (97-110 kPa) Rear: 18-20 psi (124-138 kPa)

SECTION 3 – GENERAL INFORMATION

Refer to the owner's manual provided with the vehicle for information on the following topics:

- Pre-Operation Checklist
- Controls and Indicators
- Driving Instructions
- Transporting on a Trailer
- Subsequent Owner Registration
- Warranties

SERIAL NUMBER IDENTIFICATION

The serial number of each Club Car vehicle is printed on a bar code decal mounted on the frame directly above the accelerator pedal (Example: AD0012-583947) (**Figure 3-1, Page 3-1**). There is also a second serial number decal mounted on the front body frame behind the dash panel. The dashboard must be removed to view this decal. **See following NOTE.**

NOTE: Always have the vehicle serial number at hand when ordering parts or making inquiries.

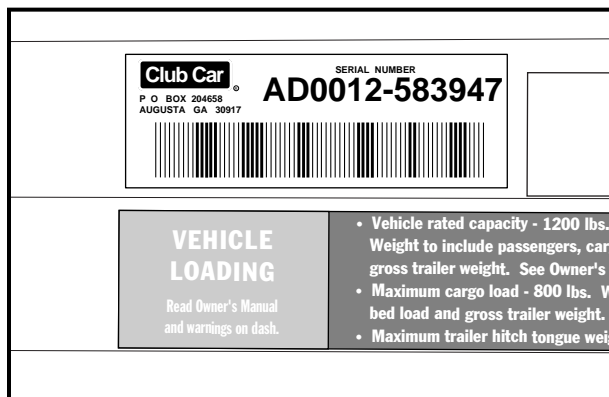

Figure 3-1 Serial Number Decal

STORAGE – GASOLINE VEHICLE

See General Warning, Section 1, Page 1-1.

PREPARING THE VEHICLE FOR EXTENDED STORAGE

1. Unload the vehicle completely, so that only minimum vehicle weight will be placed on the tires.
2. Store vehicle in a cool place. This will minimize self-discharge of the battery. If the battery appears to be weak, have it charged using an automotive-type 12-volt battery charger rated at 10 amps or less. **See following DANGER, WARNING, and CAUTION.**

⚠ DANGER

- *Never attempt to drain gasoline when the engine is hot or while it is running.*
- *Be sure to clean up any spilled gasoline before operating the vehicle.*
- *Store gasoline in an approved gasoline container only. Store in a well-ventilated area away from sparks, open flames, heaters, or heat sources.*
- *Keep gasoline out of the reach of children.*
- *Do not siphon gasoline from the vehicle.*

⚠ WARNING

- Turn the key switch OFF, remove the key, and leave the Forward/Reverse handle in the NEUTRAL position during storage. This is to prevent unintentionally starting the vehicle or a fire hazard.
- Turn fuel shut-off valve to closed (OFF) position (Figure 3-2, Page 3-3).
- Do not attempt to charge a battery if it is frozen or if the case is bulged. Discard the battery. Frozen batteries can explode.

⚠ CAUTION

- *Batteries in a low state of charge will freeze at low temperatures.*
3. Drain carburetor and seal the fuel tank.
 - 3.1. Place the Forward/Reverse handle in the NEUTRAL position. Turn the fuel shut-off valve to the closed (OFF) position and run the engine until fuel remaining in the carburetor and fuel lines is used up and the engine stalls (**Figure 3-2, Page 3-3**).
 - 3.2. Loosen (do not remove) the carburetor drain screw and drain fuel remaining in bowl into a small container, then pour the fuel from the container into vehicle fuel tank. Tighten the carburetor drain screw.
 - 3.3. Fill fuel tank to about 1 inch (2.5 cm) from top of fuel tank and, following manufacturer's directions, add a commercially available fuel stabilizer (such as Sta-Bil®).
 - 3.4. Disconnect fuel vent line from fuel tank vent nipple.
 - 3.5. Plug the fuel tank vent nipple so that it is air tight. We recommend using a slip-on vinyl cap.
 4. Disconnect the battery cables, negative cable (–) first.
 5. To protect the engine, remove spark plug and pour 1/2 ounce of SAE 10 weight oil into the engine through the spark plug hole. Rotate engine crankshaft by hand several times and then re-install the spark plug.
 6. Inflate tires to rated capacities. **See Specifications, Section 2, Page 2-2.**
 7. Grease front suspension and do all other semiannual periodic lubrication. **See Periodic Lubrication Schedule, Section 10, Page 10-4.**
 8. Thoroughly clean front body, rear body, seats, cargo bed, engine compartment, and underside of vehicle.
 9. Do not engage the park brake. Chock the wheels to prevent the vehicle from rolling.

RETURNING THE STORED VEHICLE TO SERVICE

1. Connect the battery cables, positive cable (+) first.
2. Restore fuel system to operation.

- 2.1. Remove plug from the fuel tank vent nipple and open the fuel shut-off valve (**Figure 3-3, Page 3-3**). Make sure the valve is fully open. A partially closed fuel shut-off valve combined with the use of the choke, can result in a fouled spark plug and engine failure (**Figure 3-4, Page 3-3**).
- 2.2. Place the Forward/Reverse handle in the NEUTRAL position. Crank the engine until fuel is pumped into the carburetor and fuel lines and the engine starts. Turn the engine off. **See following NOTE.**
3. Readjust tire pressure. **See Specifications, Section 2, Page 2-2.**

NOTE: Due to the oil added to the engine in preparation for storage, engine may smoke excessively for a short while when running for the first time after storage.

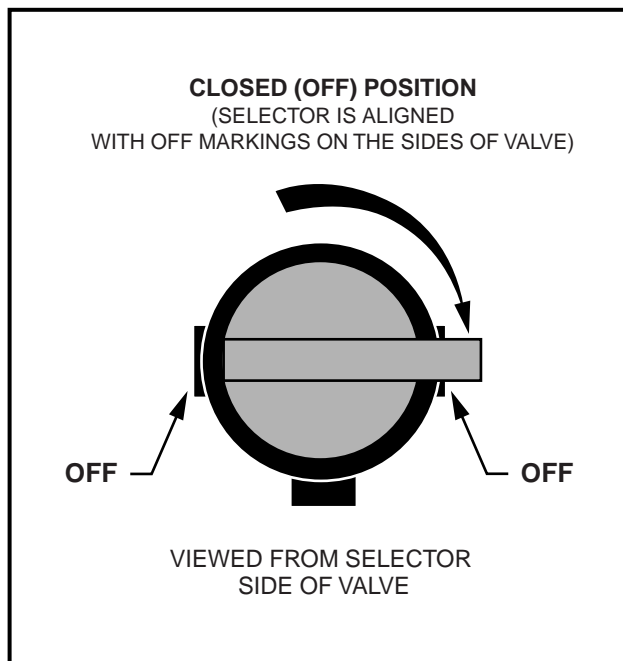

Figure 3-2 Closed Fuel Shut-off Valve

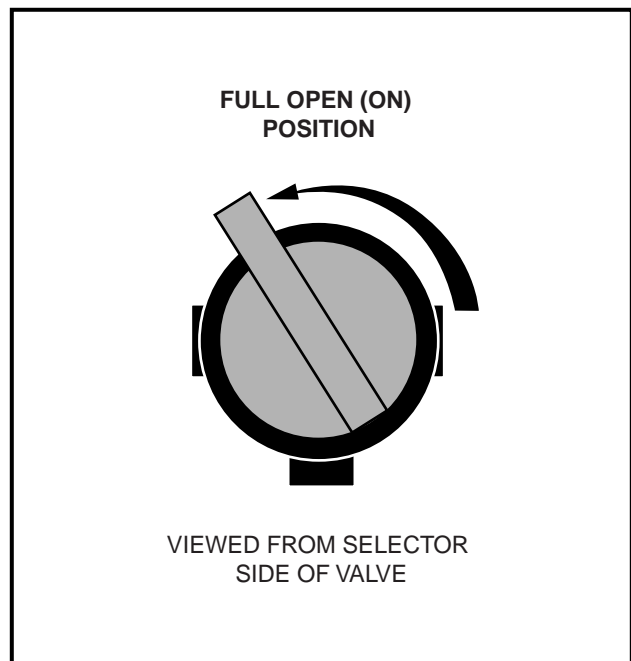

Figure 3-3 Open Fuel Shut-off Valve

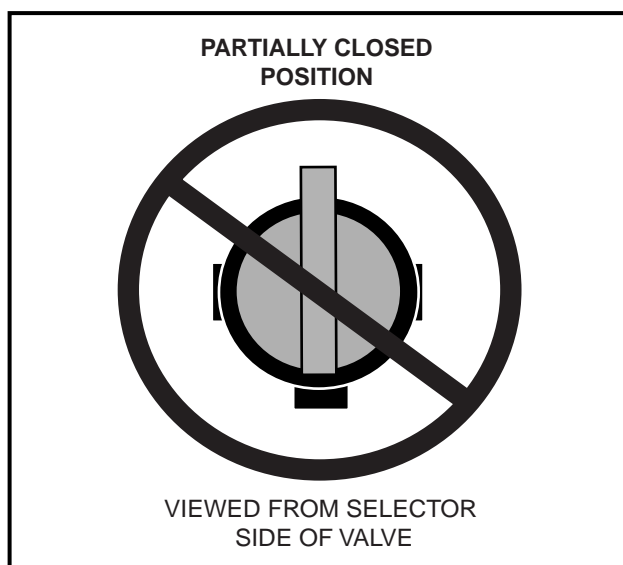

Figure 3-4 Incorrect Fuel Shut-off Valve

SECTION 4 – BODY AND TRIM

⚠ WARNING

- Only trained technicians should repair or service this vehicle. Anyone doing even simple repairs or service should have knowledge and experience in body and paint repair.
- Follow all procedures exactly as stated in this manual, and heed all **DANGER**, **WARNING**, and **CAUTION** statements in this manual as well as those affixed to the vehicle.
- Wear safety glasses or approved eye protection while servicing the vehicle. Wear a full face shield and rubber gloves when working with batteries.
- Wear a respirator approved for dust and paint mist when cutting, sanding, painting, or repairing body panels.
- Turn key switch **OFF**, place Forward/Reverse handle in the **NEUTRAL** position, and remove key before servicing the vehicle.
- Do not wear loose clothing. Remove jewelry such as rings, watches, chains, etc. before servicing vehicle.
- Use insulated tools when working near batteries or electrical connections. Use extreme caution to avoid shorting of components or wiring.
- **Moving parts!** Do not attempt to service vehicle with the engine running.
- **Hot!** Do not attempt to service hot engine or exhaust system. Failure to heed this warning can result in severe burns.
- To avoid unintentionally starting the vehicle:
 - Disconnect the battery cables, negative cable (–) first.
 - Disconnect the spark plug wire from the spark plug.

⚠ CAUTION

- Do not use detergents or cleaning solvents that contain ammonia, aromatic solvents or alkali materials on body panels or seats.
- Do not allow battery acid to drip on body panels. Battery acid will cause permanent damage. Wash spilled battery acid from body panels immediately.

CLEANING THE VEHICLE

Read WARNING and CAUTION on page 4-1.

Each vehicle is equipped with an ABS/DR acrylic front body, an all-aluminum rear body, and a powder-coated steel cargo bed. Use a commercially available automotive cleaning solution with a sponge or soft cloth for normal cleaning. A garden hose at normal residential water pressure is adequate. To remove oxidation or discoloration from aluminum, use a commercially available aluminum cleaner paste and fine grade (No. 00) steel wool.

Club Car does not recommend any type of pressure washing or steam cleaning. Such a process will expose electrical components to moisture. Moisture entering electrical components can result in water damage and subsequent component failure.

Battery acid, fertilizers, tars, asphalt, creosote, paint, or chewing gum should be removed immediately to prevent possible stains.

The front body is made of an ABS/DR acrylic material similar to the material used to manufacture hot tubs and shower/tub units. Cleaning and repair techniques for the front body are the same as those used on conventional acrylic sheet. Repair kits, cleaning and polishing products may be purchased at any hardware store where ABS/DR acrylic (hot tubs and shower/tub units) are sold.

The seats of the vehicle will last longer with proper cleaning. Use a solution of 10% liquid soap and warm water applied with a soft cloth. For imbedded dirt, a soft bristle brush may be used. For heavy soiling, difficult stains, or scratches, blemishes, or other body damage, see Seat on page 4-5. **See following NOTE.**

NOTE: Dispose of waste water properly.

FRONT BODY REPAIR

Read **WARNING** and **CAUTION** on page 4-1.

LIGHT SCRATCHES, ABRASIONS AND HAZE

The original gloss can be restored by hand buffing with “Novus Plastic Polish”, “Mirror Glaze Professional Formula Number 17” or similar polishing compounds. A buffing wheel with a small amount of tallow applied to the pad may also be used. Remember to use a very light touch, as ABS/DR acrylic polishes easily. Johnson’s “J-Wax” or “Kit” may be applied as a final treatment.

DEEPER SCRATCHES

Ajax cleanser applied dry and hand-rubbed will rapidly smooth moderate scratches. Use a soft polishing compound to restore gloss.

Scratches (up to 10 mils) can be removed by light sanding. Start with wet silicone carbide abrasive paper (320 grit or finer). Use progressively finer grits (i.e. 400, 600, 800) to reduce sanding marks. Use Ajax cleanser (or equivalent) for final smoothing. A Micro Mesh acrylic polishing kit with abrasive papers from 1800 to 8000 grit will provide the best final finish. Restore gloss with soft polishing compound.

GOUGES, PUNCTURES, TEARS, LARGE SCRATCHES, AND ABRASIONS

Touch-up is not recommended. Replace the entire body part or have it repaired by a professional paint and body repair shop with experience repairing ABS/DR acrylic bodies.

BRUSH GUARD

Read **WARNING** and **CAUTION** on page 4-1.

BRUSH GUARD REMOVAL

1. Remove the four truss head screws (14) and nuts (15) that secure the brush guard to the vehicle frame (**Figure 4-1, Page 4-4**).

BRUSH GUARD INSTALLATION

1. Installation is the reverse of removal. Tighten the four nuts (15) to 15 ft-lb (20.3 N·m) (**Figure 4-1, Page 4-4**).

FRONT BODY COMPONENTS

Read **WARNING** and **CAUTION** on page 4-1.

DASHBOARD REMOVAL

1. Remove the dash panel. **See Dash Panel Removal on page 4-3.**
2. Remove five caps (1) from top of dashboard (2) (**Figure 4-1, Page 4-4**).
3. Using a T-30 Torx head socket, remove screws (3) and washers (4) from top of dashboard (2).
4. Using a 5/16 nut driver, remove five screws (5) from underside of dashboard and pull dashboard away from front body (6).
5. Remove the steering wheel. **See Steering Wheel Removal on page 7-1.**
6. Remove dashboard from vehicle.

Dash Panel Removal

1. Remove dash panel. **See step 2 of Key Switch Removal, Section 12, Page 12-15.**
2. Disconnect wiring to electrical components.

Dash Panel Installation

1. Reconnect wiring to electrical components.
2. Reinstall the dash panel in reverse order of removal.

DASHBOARD INSTALLATION

1. Replace dashboard (2) and tighten screws (5) to 11 in-lb (1.2 N·m) (**Figure 4-1, Page 4-4**).
2. Secure dashboard to front body with five screws (3) and washers (4). Tighten screws to 45 in-lb (5.1 N·m).
3. Install five caps (1).
4. Install dash panel.
5. Install steering wheel. **See Steering Wheel Installation, Section 7, Page 7-3.**

FRONT BODY REMOVAL

1. Remove five caps (1) from top of front body (6) (**Figure 4-1, Page 4-4**).
2. Using a T-30 Torx head socket, remove screws (3) and washers (4) from top of front body (6).
3. Using a phillips head screwdriver, remove the six Tuflok fasteners (7) from sides and two from front of front body.
4. Disconnect light wiring harness from headlight assemblies.
5. Pull front body forward to clear dashboard and lift off vehicle (**Figure 4-1, Page 4-4**).

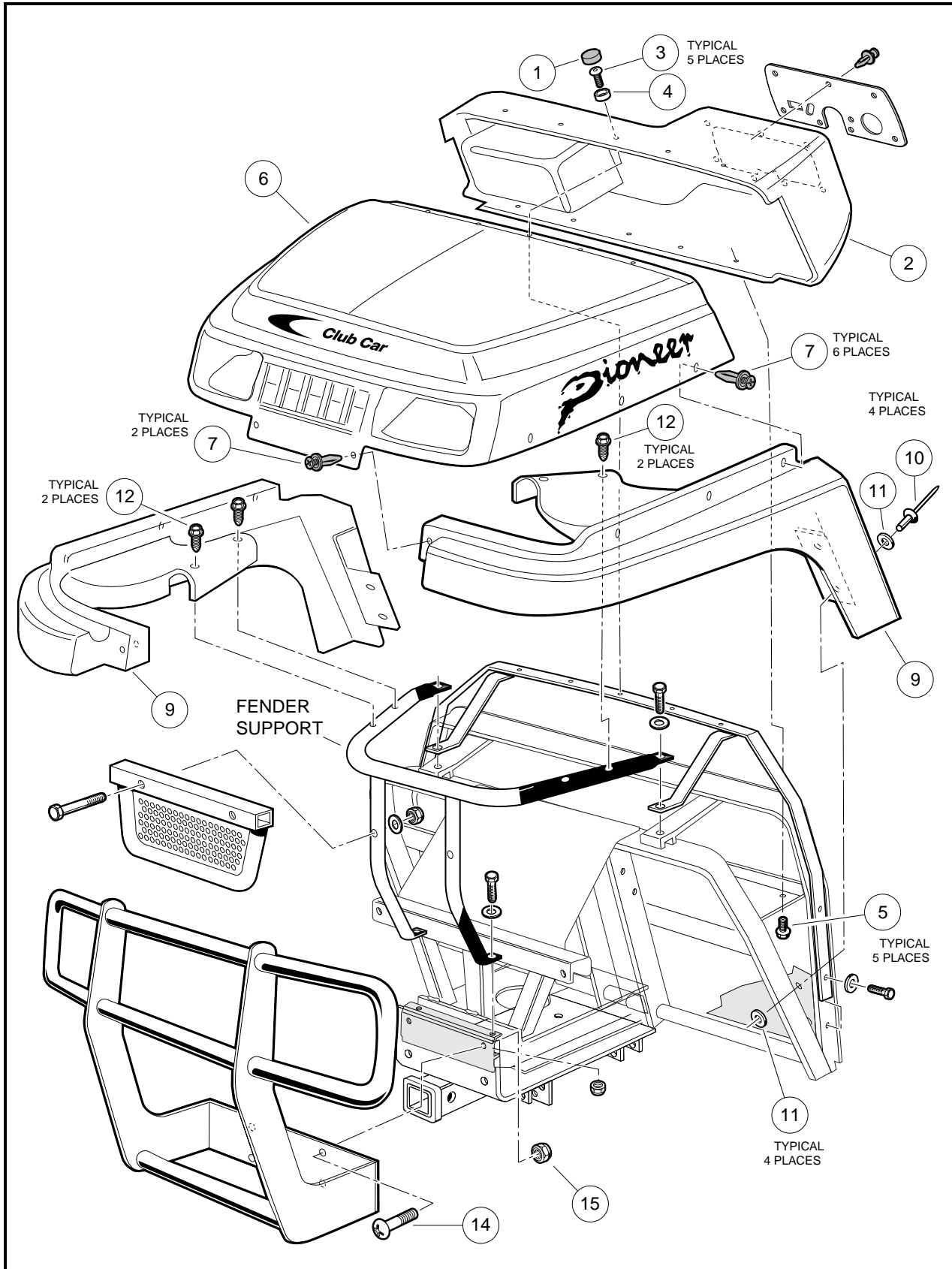

Figure 4-1 Front Body Assembly

FRONT FENDER REMOVAL

1. Remove front body (6) as instructed in **Front Body Removal on page 4-3 (Figure 4-1, Page 4-4)**.
2. Pull back floor mat to access rivets securing front fender (9). Drill out two rivets (10) and remove four washers (11) at bottom of front fender.
3. Remove two screws (12) securing fender to fender support and remove front fender from vehicle.

FRONT FENDER INSTALLATION

1. Reverse removal procedure to install front fender. Tighten screws securing fender to fender support to 50 in-lb (5.7 N·m).

FRONT BODY INSTALLATION

1. Place front body (6) onto vehicle and connect the light wiring harness to the headlight assemblies (**Figure 4-1, Page 4-4**).
2. Secure front body to dashboard with five screws (3) and washers (4). Tighten screws to 45 in-lb (5.1 N·m).
3. Install five caps (1).
4. Secure front body to fenders with eight Tuflok fasteners (7). To install the Tuflok fasteners, insert into hole and push the head in.

SEAT

Read **WARNING** and **CAUTION** on page 4-1.

To preserve seat appearance clean regularly with mild soap or detergent applied with a sponge or soft cloth. Use a soft bristle brush to clean areas that are especially soiled. Use the following guidelines:

Light Soiling – A solution of 10% liquid dish soap and warm water applied with a soft, damp cloth is recommended. A soft bristle brush may be used if necessary. Wipe off any residue with a water dampened cloth.

For Difficult Stains – Dampen a soft, white cloth with a solution of 10% household bleach (sodium hypochlorite) and 90% water. Rub gently to remove stain, then rinse with a water dampened cloth to remove bleach concentration.

For More Difficult Stains – Perform previous procedure using full-strength bleach, or allow bleach to puddle on affected area for approximately 30 minutes. Rinse with a water dampened cloth to remove any remaining bleach concentration.

⚠ CAUTION

- *To prevent damage to the vehicle when removing difficult stains or heavy soiling, remove the seat from the vehicle first.*

SEAT REMOVAL

1. Pull seat forward and lift up to remove from seat support (1).

Seat Adjustment

1. Remove seat from vehicle.
2. Disassemble bucket seat (2) from seat panel (3) by removing four bolts (4) and lock washers (5) (**Figure 4-2, Page 4-7**).
3. Adjust seat to suit. Align holes in seat panel with holes in bucket seat and secure with four bolts and lock washers. Tighten bolts to 96 in-lb (10.8 N·m).

SEAT INSTALLATION

1. Align seat hinge plates with holes in seat support, lower seat and press down to lock in place. **See following WARNING.**

⚠ WARNING

- Make sure seat hinges and latch are securely engaged before operating vehicle.

SEAT SUPPORT

Read **WARNING** and **CAUTION** on page 4-1.

SEAT SUPPORT REMOVAL

1. Completely remove both seats from the vehicle.
2. Remove park brake cable from park brake lever. **See Equalizer Cable Removal, Section 6, Page 6-31.**
3. Disconnect cable from differential lock control. **See step 3.5 of Unitized Transaxle Removal, Section 16, Page 16-9.**
4. Remove the four bolts (8), eight washers (9) and four lock nuts (10) from the seat support (**Figure 4-2, Page 4-7**).
5. Remove the two armrests (11 and 12) from the seat support (**Figure 4-2, Page 4-7**).
6. Lift seat support from vehicle.

SEAT SUPPORT INSTALLATION

1. Install the seat support and armrests. Tighten bolts (8) to 13 ft-lb (17.6 N·m) (**Figure 4-2, Page 4-7**).
2. Reconnect differential lock cable end to the differential lock handle. **See step 33 of Unitized Transaxle Installation, Section 16, Page 16-44.**
3. Reinstall park brake cable. **See Equalizer Cable Installation, Section 6, Page 6-33.**

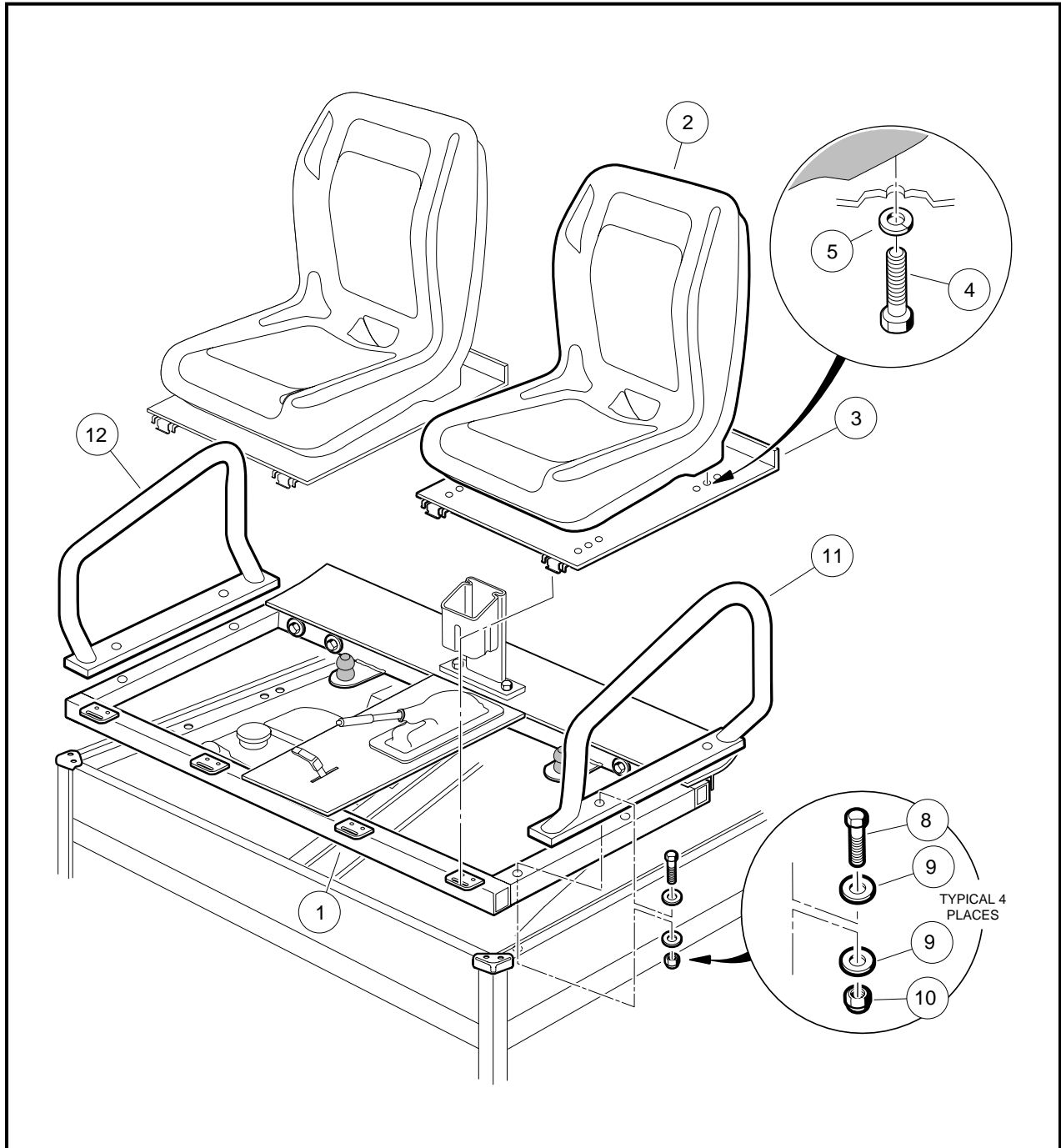

Figure 4-2 Seat Support

ARMREST REMOVAL

1. Perform steps 1, 4 and 5 of Seat Support Removal on page 4-6. **See also following WARNING.**

▲ WARNING

- Both armrests must be installed before operating the vehicle, unless the vehicle is fitted with a structural cab.

ARMREST INSTALLATION

1. Install the armrests and tighten bolts (8) to 13 ft-lb (17.6 N-m) **(Figure 4-2, Page 4-7)**.

TILT BED

Read **WARNING** and **CAUTION** on page 4-1.

NOTE: Tilt bed removal and installation will be easier with a helper.

TILT BED REMOVAL

1. Raise bed and ensure that the prop rod (1) is secured in the prop rod track (2). Hold bed securely in an upright position. Remove cotter pin (3) and flat washer (4) from top end of prop rod where prop rod attaches to bed. Remove prop rod (1) from bed and place prop rod between prop rod track (2) and rear body panel. Lower bed onto vehicle frame **(Figure 4-3, Page 4-9)**.
2. Remove two locknuts (8) from left and right tilt bed hinge assemblies (15) **(Figure 4-3, Page 4-9)**.
3. Apply slight upward pressure (by hand) on the rear of the bed to relieve pressure on the hinges and remove the hinge bolts (9) from the hinge assemblies.
4. Raise rear edge of bed approximately 6 inches (15.2 cm) and pull bed assembly toward rear of vehicle approximately 3 inches (7.6 cm) to release bed latch assembly (10) from latch plate (11) **(Figure 4-3, Page 4-9)**.
5. Lift bed from vehicle.

TILT BED INSTALLATION

1. Hold bed at a slight angle (front of bed lower than rear of bed) to vehicle and place front edge of bed onto vehicle frame. Bed latches (10) should be engaged with latch plates (11) **(Figure 4-3, Page 4-9)**.
2. Lower edge of bed onto vehicle and align hinge brackets (15) with bed hinge (14) **(Figure 4-3, Page 4-9)**.
3. Start the bolts (9) into left and right hinge assemblies (14 and 15). It may be necessary to use an alignment tool to align holes in hinge bracket with steel bushing in hinge assembly **(Figure 4-3, Page 4-9)**.
4. Use a small hammer to lightly tap bolts through hinge assembly.
5. Install a nylon locknut (8) on each bolt (9) and tighten to 15 ft-lb (21 N-m) **(Figure 4-3, Page 4-9)**.
6. Lift bed and place the prop rod (1) in bed mounting hole. Install a 3/8 inch flat washer (4) and a **new** cotter pin (3) on prop rod **(Figure 4-3, Page 4-9)**.
7. Proceed to Bed Stop Bumper Adjustment.

BED STOP BUMPER ADJUSTMENT

1. Adjust the front two bumpers (16) by loosening the locknut (17) and positioning the bumper in the slot so that when the tilt bed is lowered, the bumper is centered on the bed frame weldment **(Figure 4-3, Page 4-9)**.
2. Tighten the locknut (17) to secure bumper to 20 in-lb (2.3 N-m).
3. Adjust the two rear bumpers (18) by tightening or loosening the nut (19) until a 3/16 inch gap between the bottom of the bumper head and the frame weldment is achieved. These bumpers are not to be tightened completely down; they are designed to "float".

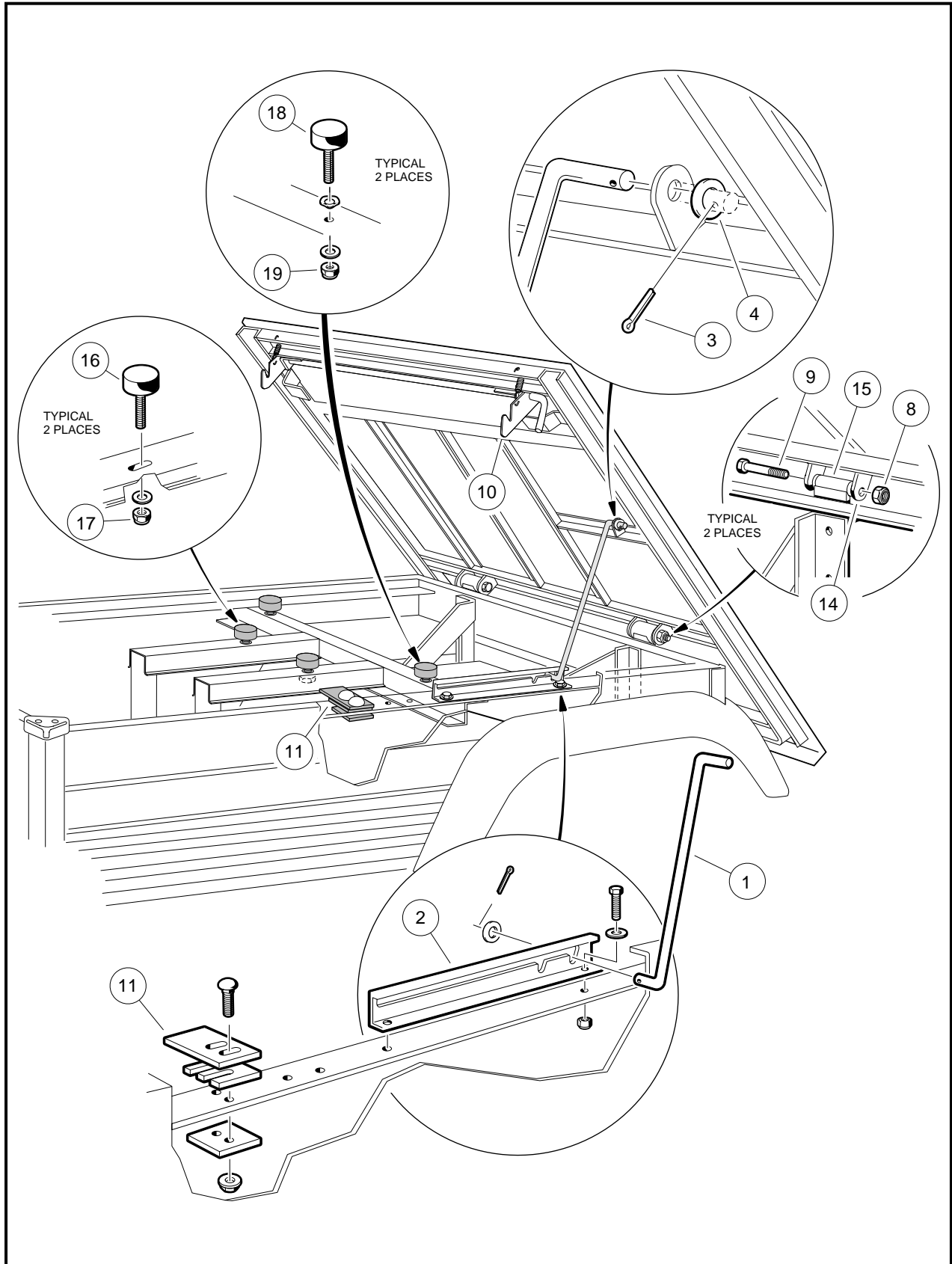

Figure 4-3 Tilt Bed

REAR FENDER

Read **WARNING** and **CAUTION** on page 4-1.

REAR FENDER REMOVAL

1. Remove two nylon locknuts (5) and flat washers (4) from front of fender. Remove two bolts (3) from front of fender (1) (**Figure 4-4, Page 4-11**).
2. Remove two nylon locknuts (7) and flat washers (8) from top of fender (1). Remove two bolts (9) and flat washer (8) from underneath fender.
3. Remove the two nylon locknuts (27), washers (26) and bolts (25).
4. Remove fender (1) and fender guard (28) from the vehicle.

REAR FENDER INSTALLATION

1. Reverse removal procedure to install rear fender. Tighten bolts securing the fender and fender guard to the vehicle to 35 in-lb (4.0 N·m).

NOTE: The rear fender with the warning decal should be installed on the passenger side of the vehicle. The decal should be plainly visible when the cargo bed is raised.

TAILSKIRT

Read **WARNING** and **CAUTION** on page 4-1.

TAILSKIRT REMOVAL

1. Remove two thread-forming screws (12) from tailskirt (13) and lift tailskirt from vehicle frame (**Figure 4-4, Page 4-11**).

TAILSKIRT INSTALLATION

1. Insert upper edge of tailskirt (13) under, and in front of, back edge of rear body (**Figure 4-4, Page 4-11**).
2. Align holes in tailskirt (13) with holes in vehicle frame. Position tailskirt flush against frame (**Figure 4-4, Page 4-11**).
3. Install two thread-forming screws (12) in tailskirt and tighten to 55 in-lb (6.2 N·m) (**Figure 4-4, Page 4-11**).

RECEIVER HITCH

Read **WARNING** and **CAUTION** on page 4-1.

RECEIVER HITCH REMOVAL

1. Remove the tailskirt. **See Tailskirt Removal on page 4-10.**
2. Where the hitch (14) is mounted to frame, remove two nuts (15), lock washers (16) washers (17) and bolt (18).
3. Where the hitch (14) is mounted to hitch brace (20), remove the nut (24), lock washer (23), washer (22) and bolt (21).
4. Remove hitch (14) from vehicle.

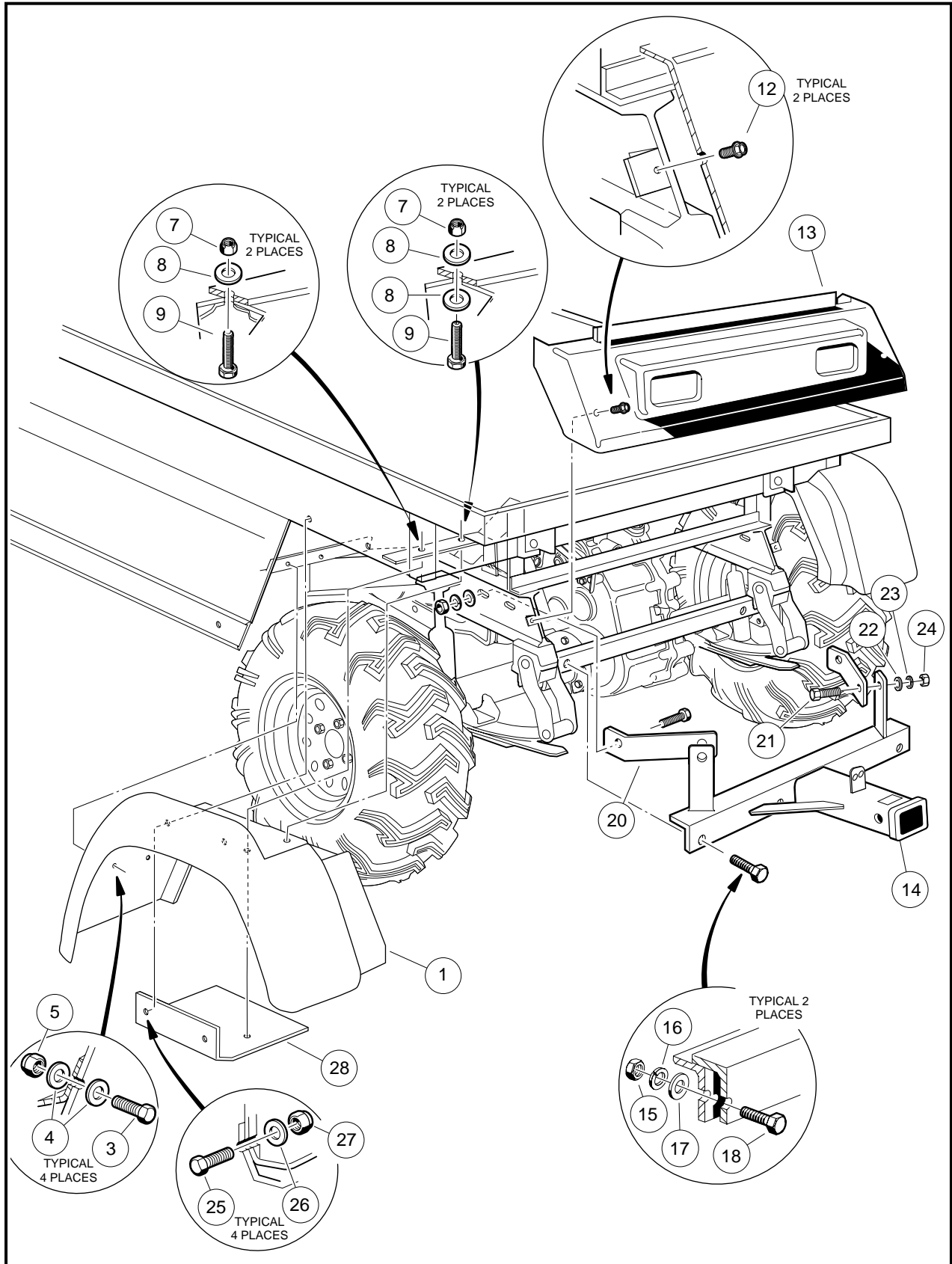

Figure 4-4 Rear Fender, Tailskirt, and Receiver Hitch

RECEIVER HITCH INSTALLATION

1. Reverse removal procedures to install hitch (14). Tighten hardware to 15 ft-lb (20.3 N·m) (**Figure 4-4, Page 4-11**).

FLOOR MAT

Read **WARNING** and **CAUTION** on page 4-1.

FLOOR MAT REMOVAL

1. Remove the brake and accelerator pedals. **See Section 5 – Accelerator and Brake Pedal Assemblies.**
2. Remove the top edge of the floor mat from the overlapping flange under the dash.
3. Lift the mat from the vehicle.

FLOOR MAT INSTALLATION

1. Install the floor mat in the reverse order of removal.
2. Install the brake and accelerator pedals. **See Section 5 – Accelerator and Brake Pedal Assemblies.**

SECTION 5 – ACCELERATOR AND BRAKE PEDAL ASSEMBLIES

▲ WARNING

- Only trained technicians should repair or service the vehicle. Anyone doing even simple repairs or service should have knowledge and experience in electrical and mechanical repair.
- Follow the procedures exactly as stated in this manual, and heed all DANGER, WARNING, and CAUTION statements in this manual as well as those affixed to the vehicle.
- Improper use of the vehicle or failure to properly maintain the vehicle, could result in decreased vehicle performance or severe personal injury.
- Any modification or change to the vehicle that affects the stability or handling, or increases maximum vehicle speed beyond factory specifications, could result in severe personal injury or death.
- Wear safety glasses or approved eye protection when servicing the vehicle. Wear a full face shield and rubber gloves when working with batteries.
- Do not wear loose clothing. Remove jewelry such as rings, watches, chains, etc. before servicing vehicle.
- Moving parts! Do not attempt to service the vehicle while it is running.
- Hot! Do not attempt to service hot engine or exhaust systems. Failure to heed this warning could result in severe burns.
- Use insulated tools when working near batteries or electrical connections. Use extreme caution to avoid shorting of components or wiring.
- Turn the key switch to OFF, remove the key, chock the wheels, place the Forward/Reverse handle in NEUTRAL and disconnect battery prior to servicing the vehicle.
- To avoid unintentionally starting the vehicle:
 - Disconnect battery cables, negative cable (–) first. See Figure 1-1, Section 1, Page 1-2.
 - Disconnect the spark plug wire from the spark plug.
- Frame ground – Do not allow tools or other metal objects to contact frame when disconnecting battery cables or other electric wiring. Never allow a positive wire to touch the vehicle frame, engine, or any other metal component.
- Lift only one end of the vehicle at a time. Before lifting, set the park brake when lifting the front of the vehicle, unload the cargo bed and chock the wheels that remain on the floor. Use a suitable lifting device (chain hoist or hydraulic floor jack) with 1000 lb. (454 kg) minimum lifting capacity. Do not use lifting device to hold vehicle in raised position. Use approved jack stands of proper weight capacity to support the vehicle.

BRAKE PEDAL ADJUSTMENT

Read **WARNING** on page 5-1.

1. Chock wheels and release the park brake.
2. Remove the rod retaining bolt (8) and remove the clevis (16) from the bell crank assembly (11) (**Figure 5-1, Page 5-2**).
3. Loosen the brake stop jam nut (31) (**Figure 5-2, Page 5-3**).

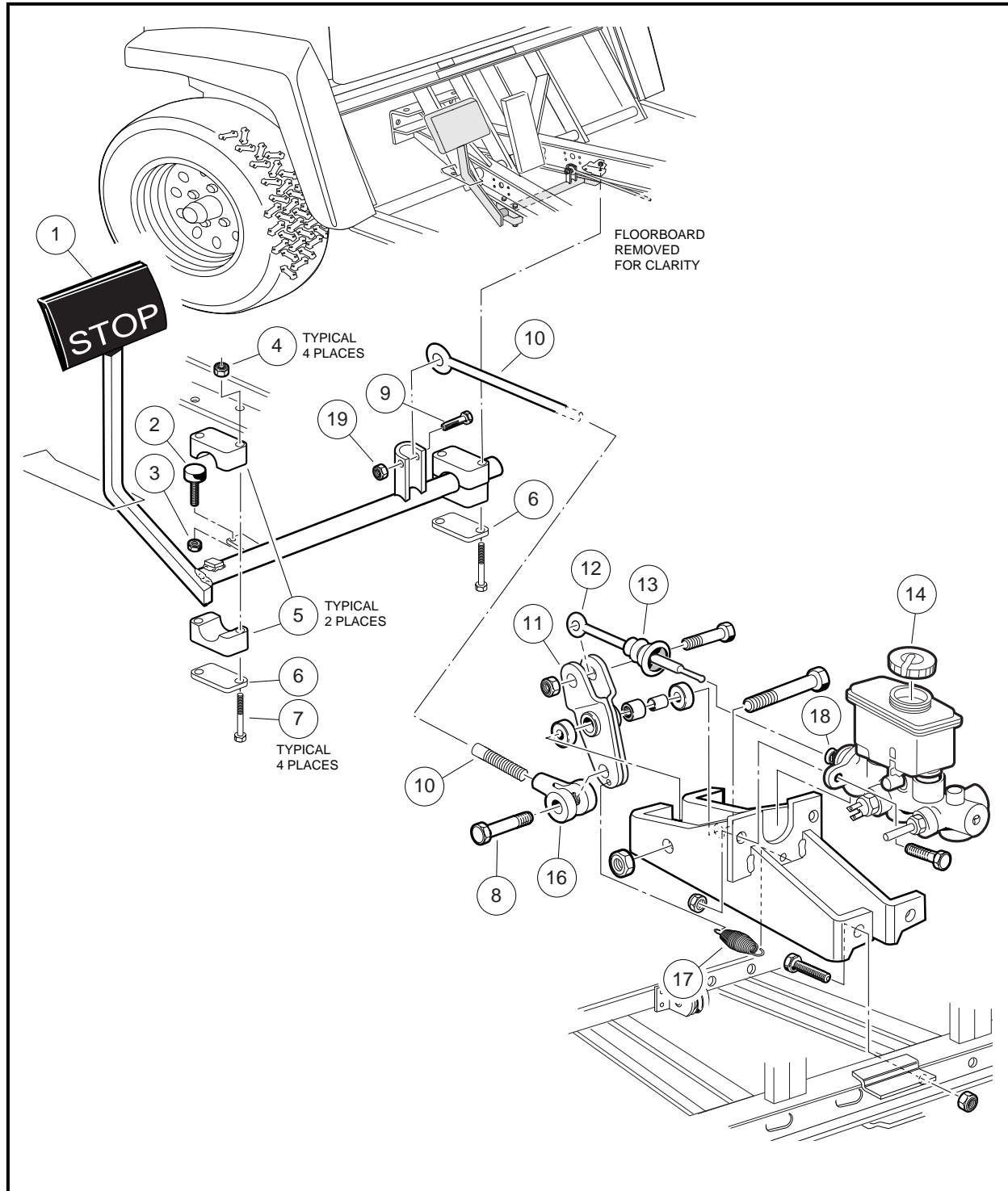

Figure 5-1 Brake Pedal Assembly

4. Pull the brake pedal toward the rear of the vehicle until the brake stop bumper will not allow the pedal to travel any further (**Figure 5-3, Page 5-3**).
5. While holding the brake pedal in this position, measure the distance from the back of the brake pedal to the floorboard (**Figure 5-3, Page 5-3**). If the measured distance is between 6-3/8 inches (16.2 cm) and 6-7/8 inches (17.5 cm), proceed to step 9.

6. Adjust the brake stop bumper (22) up or down (**Figure 5-2, Page 5-3**). Adjusting the bumper upward decreases the distance between the pedal and the floorboard. Adjusting the bumper downward increases the distance between the pedal and the floorboard. Proper brake pedal height is 6-5/8 inches \pm 1/4 inch (16.8 cm \pm 6 mm) (**Figure 5-3, Page 5-3**).

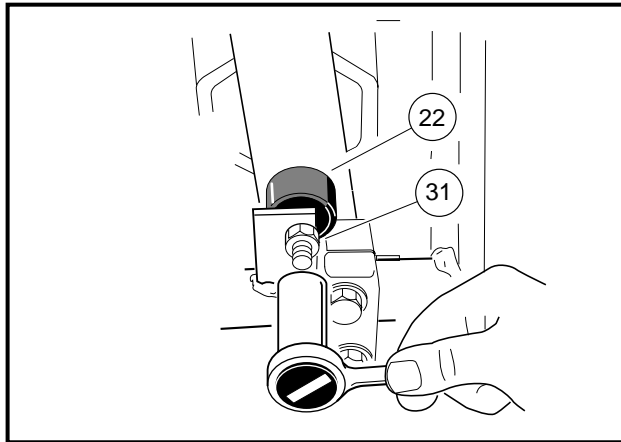

Figure 5-2 Adjust Brake Pedal Height

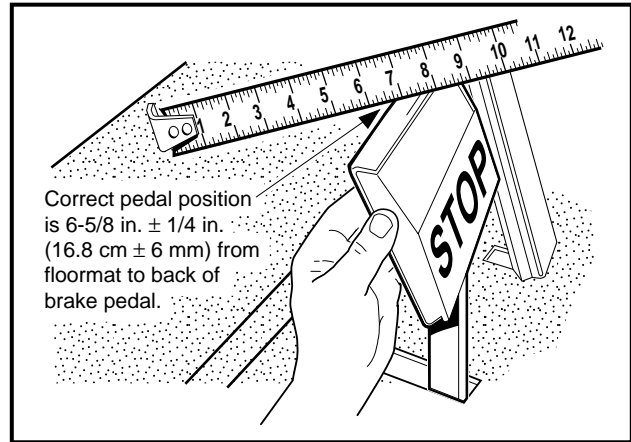

Figure 5-3 Measure Brake Pedal Height

7. Tighten the jam nut (31) to 8 ft-lb (9.5 N·m) (**Figure 5-2, Page 5-3**).
8. Adjust the clevis (16) by rotating it clockwise or counterclockwise so that the rod retaining bolt (8) can easily be placed through the clevis (16) and the bottom hole in the bell crank assembly (11) (**Figure 5-1, Page 5-2**).

NOTE: The spring (17) should not be under tension while the brake pedal is at rest (**Figure 5-1, Page 5-2**).

9. Install the rod retaining bolt (8) through the clevis (16) and the bell crank (11). Tighten the bolt to 14 ft-lb (19 N·m) (**Figure 5-1, Page 5-2**).
10. While observing the push rod, press the brake pedal. There should be at least 1/8 inch of free play (at the push rod) before the push rod begins to depress the master cylinder piston (**Figure 5-4, Page 5-4**). An accurate measurement is not necessary, but it must be a minimum of 1/8 inch so that the push rod does not contact the master cylinder piston when the pedal is at rest.

NOTE: Brake pedal free play is the distance the push rod (12) travels before the master cylinder piston (18) is depressed (**Figure 5-1, Page 5-2**). See also **Figure 5-4, Page 5-4**.

11. Perform all of the brake system inspections in Section 6 to ensure that both the hydraulic brake system and the park brake system are adjusted correctly and are operating correctly before placing the vehicle into service. See **Brake System Inspection, Section 6, Page 6-2**.

ACCELERATOR PEDAL ADJUSTMENT

Read WARNING on page 5-1.

1. Measure the distance from the top of the accelerator pedal to the floorboard. If the distance is within the range of 5-3/4 inches \pm 1/4 inch (14.6 cm \pm 6mm) (**Figure 5-5, Page 5-4**), adjusting the accelerator pedal is not necessary. Proceed to Step 5.
2. Loosen the nut and bolt securing the accelerator pedal to the pivot plate (**Figure 5-6, Page 5-4**).
3. If using an accelerator pedal adjustment tool to make adjustment:
 - 3.1. Clamp the accelerator pedal adjustment tool (CCI 101871001) to the accelerator pedal, with the end marked **accelerator pedal height** closest to the floorboard.

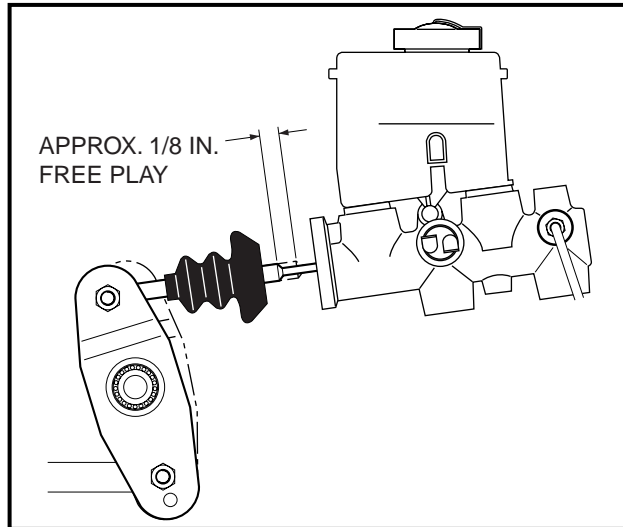

Figure 5-4 Push Rod Free Play

- 3.2. Depress the accelerator pedal until the end of the tool rests against the floorboard. Using a rubber strap, hold pedal in position against the floorboard and tighten nut to 26 ft-lb (35.3 N·m) (**Figure 5-7, Page 5-5**).
4. If using a tape measure to make adjustment:
 - 4.1. Place the end of the tape measure against the floormat and adjust the pedal so the distance from the floormat to the back of the accelerator pedal is 5-3/4 inches \pm 1/4 inch (14.6 cm \pm 6mm) (**Figure 5-7, Page 5-5**).

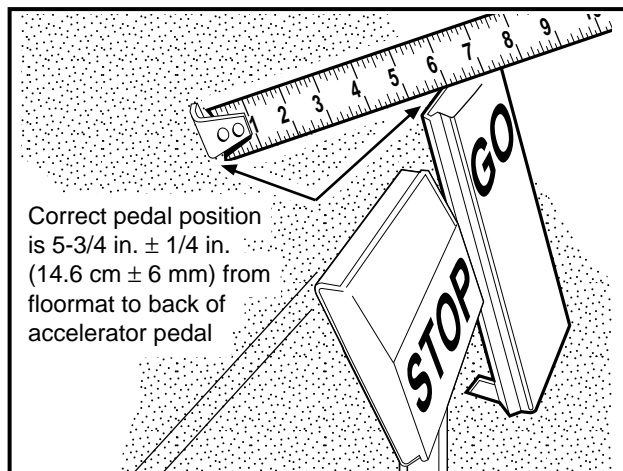

Figure 5-5 Accelerator Pedal Height

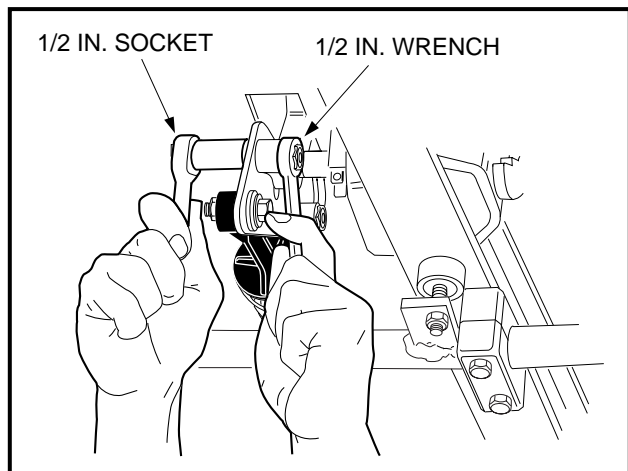

Figure 5-6 Accelerator Pedal Adjustment

5. Adjust the accelerator rod.

⚠ DANGER

- **Before servicing, turn the key switch to OFF and place the Forward/Reverse handle in the NEUTRAL position.**
- **To prevent accidentally starting the vehicle, disconnect the battery as instructed in WARNING on page 5-1. This will prevent the possibility of the vehicle running over you when you are adjusting the accelerator rod.**

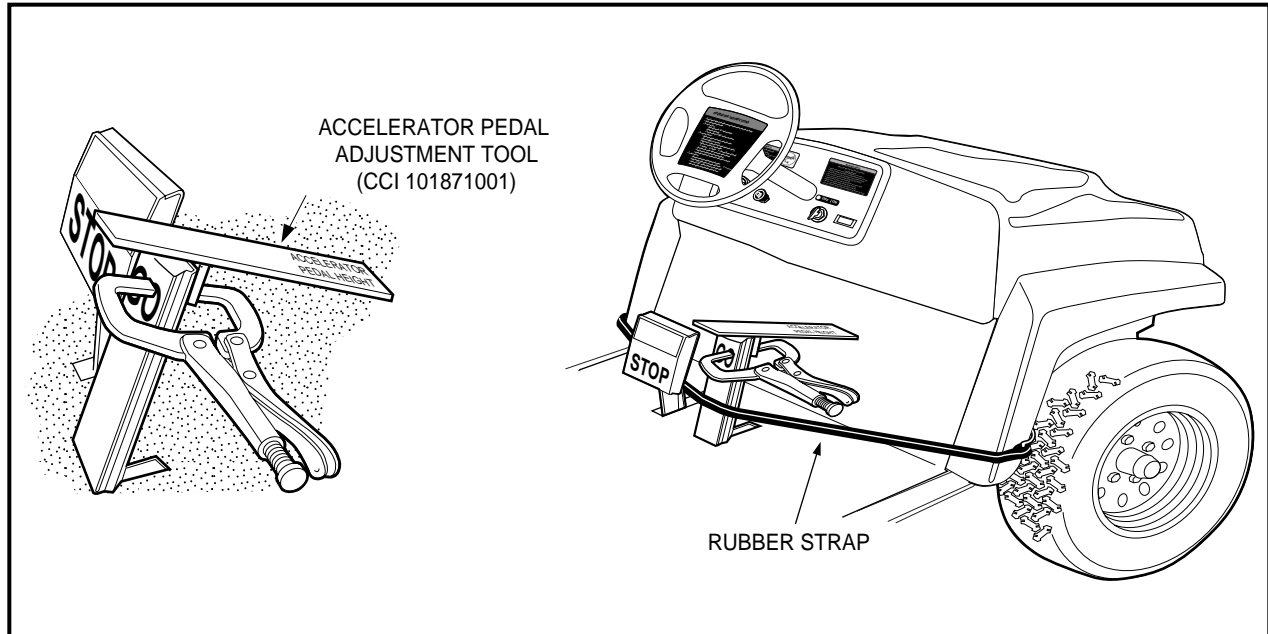

Figure 5-7 Accelerator Pedal Height Adjustment

- 5.1. Remove the electrical box screw and cover. **See preceding DANGER.**
- 5.2. Loosen the jam nuts (18) and disconnect the accelerator rod (17) at the accelerator pedal (**Figure 5-9, Page 5-6**). Adjust the length of the rod so the indicated cam edge is parallel with the edge of the electrical component box as shown (**Figure 5-8, Page 5-5**). **See following CAUTION.**

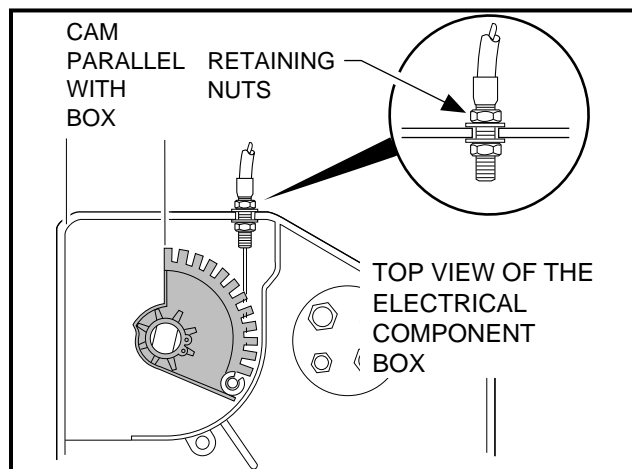
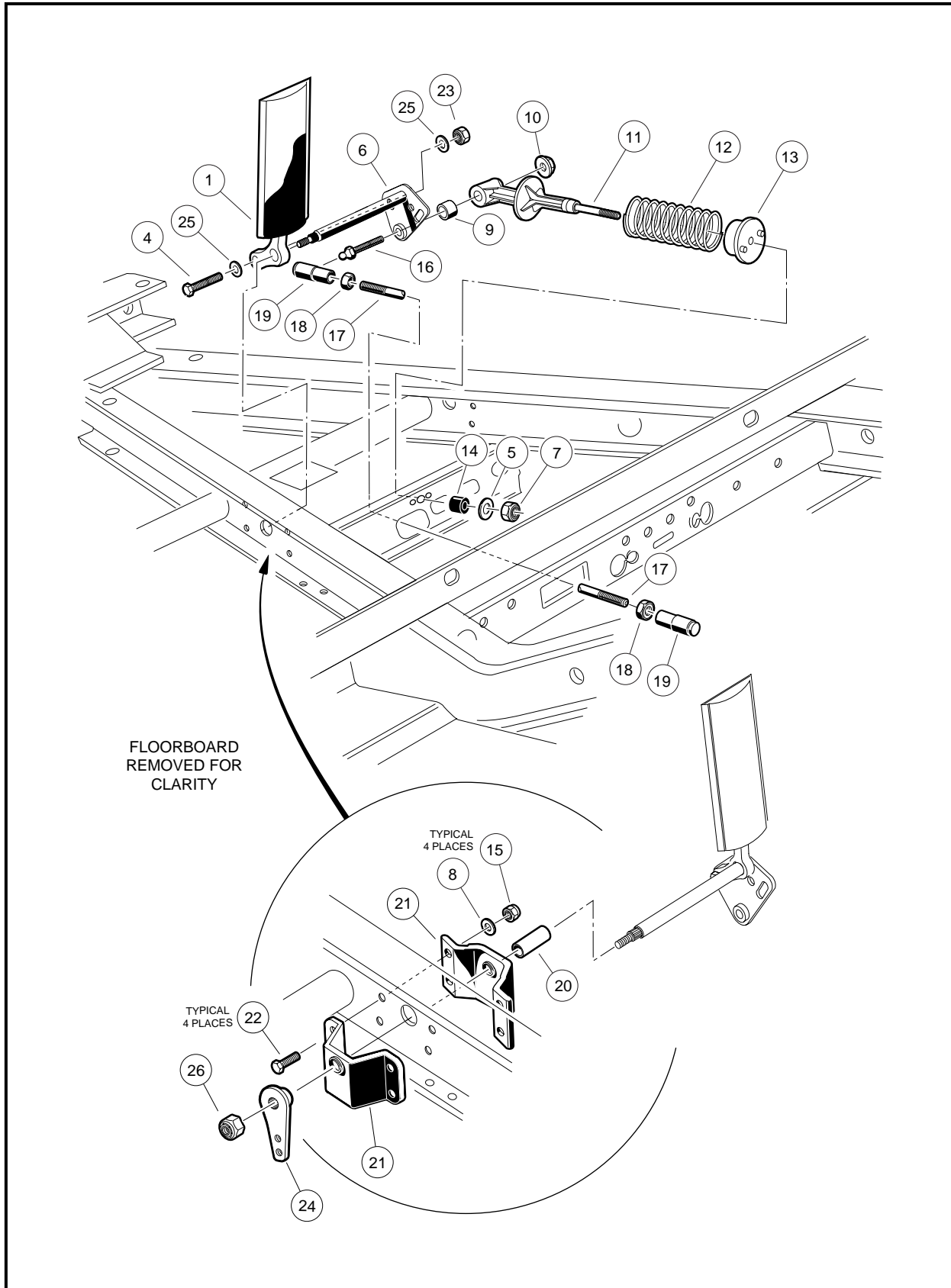

Figure 5-8 Accelerator Cable

⚠ CAUTION

- After accelerator rod adjustment, make sure that approximately the same number of threads are exposed at each end of the accelerator rod.
- When loosening jam nuts on the accelerator rod with one end disconnected, hold the disconnected accelerator rod with locking pliers.
- When tightening jam nuts on the accelerator rod, hold the disconnected ball joint with locking pliers.



Accelerator Pedal Adjustment, Continued:

- 5.3. Reconnect the accelerator rod at the accelerator pedal.
- 5.4. Before tightening jam nuts on accelerator rod, depress accelerator pedal and make sure the carburetor throttle actuates when the pedal is depressed approximately 8° to 12°.

NOTE: *After* the accelerator pedal and rod are adjusted, the final governed engine RPM should be set to 3800 (±30) RPM. **See Engine RPM Adjustment, Section 14, Page 14-13.**

- 5.5. Hold the ball joint at each end of the accelerator rod with pliers and tighten the accelerator rod jam nut against it.
- 5.6. Ensure that the events occur as described in step 5.4 above.
- 5.7. Install the electrical box cover and screw.

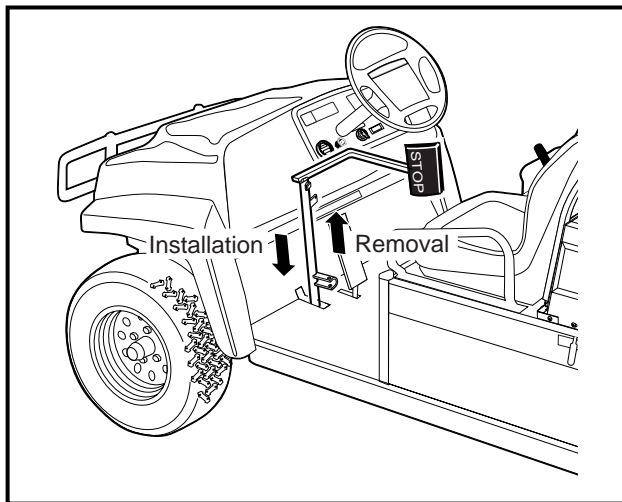

Figure 5-10 Brake Pedal Weldment Through Floor

BRAKE PEDAL

Read **WARNING** on page 5-1.

BRAKE PEDAL REMOVAL

1. Make sure key switch is OFF and the Forward/Reverse handle is in NEUTRAL, then disconnect battery and spark plug as instructed in **WARNING** on page 5-1.
2. Place chocks under rear wheels and lift front end of vehicle with a chain hoist or floor jack. Place jack stands under the front cross tube of the vehicle frame and lower the vehicle onto the jack stands. **See following WARNING.**

▲ WARNING

- Lift only one end of the vehicle at a time. Before lifting, unload cargo bed, lock the brakes and chock the wheels that remain on the floor. Use a suitable lifting device (chain hoist or hydraulic floor jack) with 1000 lb. (454 kg) minimum lifting capacity. Do not use lifting device to hold vehicle in raised position. Use approved jack stands of proper weight capacity to support the vehicle.
3. Remove the brake pedal assembly.

- 3.1. Remove the bolt (9) and nut (19) from the brake pedal weldment (**Figure 5-1, Page 5-2**).
- 3.2. Remove nuts (4), retaining plates (6), bolts (7), and mounting blocks (5). If the mounting blocks (5) show signs of excessive wear, or are damaged, they must be replaced with new ones before installing pedal assembly (**Figure 5-1, Page 5-2**).
- 3.3. Remove the nut (3) and brake stop (2) (**Figure 5-1, Page 5-2**).
- 3.4. Lift pedal assembly (1) through the floorboard (**Figure 5-1, Page 5-2 and Figure 5-10, Page 5-7**).

BRAKE PEDAL INSTALLATION

1. From the top side of the floorboard, insert the brake pedal weldment assembly (1) (**Figure 5-1, Page 5-2**) through the opening in the floor as shown (**Figure 5-10, Page 5-7**) and install the pedal stop (2) and nut (3) (**Figure 5-1, Page 5-2**) on the weldment.
2. Attach the equalizer rod (10) to the brake pedal weldment assembly (1) as shown (**Figure 5-1, Page 5-2**). Tighten to 17 in-lb (23 N·m).
3. Position and attach brake pedal assembly and mounting blocks (5) to vehicle frame as shown. Tighten to 50 in-lb (6.5 N·m) (**Figure 5-1, Page 5-2**).
4. Pull the brake pedal toward the rear of the vehicle until the brake stop bumper will not allow the pedal to travel any further (**Figure 5-3, Page 5-3**).
5. To adjust the brake pedal, perform steps 4 through 11 of Brake Pedal Adjustment on page 5-1.

ACCELERATOR PEDAL

Read **WARNING** on page 5-1.

ACCELERATOR PEDAL REMOVAL

1. Make sure the key switch is OFF and the Forward/Reverse handle is in NEUTRAL, then disconnect the battery and spark plug as instructed in the **WARNING** on page 5-1.
2. Place chocks under the rear wheels and lift the front end of the vehicle with a chain hoist or floor jack. Place jack stands under front cross tube of the vehicle frame and lower the vehicle onto the jack stands.
3. Remove the nut (23), two washers (25), and bolt (4) securing the accelerator pedal (1) to the pivot rod (6) (**Figure 5-9, Page 5-6**).
4. Disconnect the accelerator rod assembly (17, 18 and 19) (**Figure 5-9, Page 5-6**) at the front and rear ball studs and remove it from the vehicle.
5. Remove the nut (10) and ball stud (16) from the accelerator pivot rod assembly (6) (**Figure 5-9, Page 5-6**).
6. Slide the spring retainer (11) off of the accelerator pivot rod (**Figure 5-9, Page 5-6**).
7. Remove lock nut (26) from the accelerator pivot shaft (**Figure 5-9, Page 5-6**).
8. Depress brake pedal slightly and then slide the spacer (24) toward end of accelerator pivot rod. Rotate the spacer (26) and remove from the pivot rod (6) (**Figure 5-9, Page 5-6**).
9. Remove pivot rod (6) from accelerator pivot rod supports (21).
10. Inspect the accelerator pivot rod supports (21) for wear or damage and replace as necessary. If the pivot rod supports do not require replacement, loosen (but do not remove) the four bolts (22) and lock nuts (15) to make installation of the pivot rod easier (**Figure 5-9, Page 5-6**).
11. Remove nylon spacer (20) (**Figure 5-9, Page 5-6**).

12. Remove the accelerator pedal (1) from the vehicle (**Figure 5-9, Page 5-6**).
13. Inspect all parts for wear and damage and replace as necessary.

ACCELERATOR PEDAL INSTALLATION

1. If the accelerator pivot rod supports were replaced, position the supports (21) on the vehicle frame and install the four bolts (22), flat washers (8) and lock nuts (15). Finger tighten nuts at this time (**Figure 5-9, Page 5-6**).
2. Insert lower end of accelerator pedal (1) through floorboard and install accelerator pivot rod (6) through uppermost hole in pedal. Insert bolt (4) through lower hole in pedal and through pivot rod (6). Install two washers (25), and nut (23) onto bolt. Finger tighten nut (**Figure 5-9, Page 5-6**).
3. Install plastic spacer (20) on pivot rod (**Figure 5-9, Page 5-6**).
4. Insert the pivot rod through the pivot rod supports (21) on the vehicle frame (**Figure 5-9, Page 5-6**).
5. Tighten four bolts (22) (**Figure 5-9, Page 5-6**) attaching pivot rod supports to frame to 75 in-lb (8.5 N·m).
6. Install the ball stud (16) through the pivot rod (6). Install the spring retainer onto the boss of the pivot rod plate. Secure these parts with nut (10) (**Figure 5-9, Page 5-6**). Tighten nut to 50 in-lb (5.5 N·m).
7. Install spacer (24) and nylon lock nut (26) (**Figure 5-9, Page 5-6**) on the pivot rod. Tighten the nut to 18 ft-lb (24.5 N·m).
8. Install the accelerator rod assembly (17, 18 and 19) (**Figure 5-9, Page 5-6**).
9. Adjust the accelerator pedal and accelerator rod. **See Accelerator Pedal Adjustment on page 5-3.**

SECTION 6 – HYDRAULIC AND PARK BRAKE SYSTEMS

▲ WARNING

- Only trained technicians should repair or service the vehicle. Anyone doing even simple repairs or service should have knowledge and experience in electrical and mechanical repair.
- Follow all procedures exactly as stated in this manual, and heed all DANGER, WARNING, and CAUTION statements in this manual as well as those affixed to the vehicle.
- Wear safety glasses or approved eye protection while servicing vehicle. Wear a full face shield and rubber gloves when working with batteries.
- Some brake shoes contain asbestos fiber, and asbestos dust is created when these brake mechanisms are handled. Wear approved eye and respiratory protection when disassembling and cleaning brake mechanisms. Inhalation of asbestos could result in severe personal injury or death. Do not use compressed air or aerosol sprays to clean the brake mechanism. Clean brake mechanisms using the negative pressure enclosure/HEPA vacuum system or low pressure/wet cleaning method per OSHA/29 CFR -1910.1001.
- Turn key switch OFF, place Forward/Reverse handle in the NEUTRAL position and remove key prior to servicing.
- Do not wear loose clothing. Remove jewelry such as rings, watches, chains, etc. before servicing vehicle.
- Moving parts! Do not attempt to service the vehicle while it is running.
- Use insulated tools when working near batteries or electrical connections. Use extreme caution to avoid shorting of components or wiring.
- To avoid unintentionally starting the vehicle:
 - Disconnect battery cables, negative cable (–) first.
 - Disconnect the spark plug wire from the spark plug.
- Frame ground – Do not allow tools or other metal objects to contact frame when disconnecting battery cables or other electric wiring. Never allow a positive wire to touch the vehicle frame, engine or any other metal component.
- Lift only one end of the vehicle at a time. Before lifting, set the park brake when lifting the front of the vehicle, unload the cargo bed and chock the wheels that remain on the floor. Use a suitable lifting device (chain hoist or hydraulic floor jack) with 1000 lb. (454 kg) minimum lifting capacity. Do not use lifting device to hold vehicle in raised position. Use approved jack stands of proper weight capacity to support the vehicle.

GENERAL INFORMATION

The Pioneer 1200 vehicle is equipped with two types of shoe drum braking systems: a hydraulic, four-wheel braking system for normal stopping, and a hand-activated mechanical rear-wheel park brake system for retaining the vehicle when it is stationary.

The hydraulic brake system consists of a hydraulic brake cluster on each wheel and a master cylinder. Each cluster utilizes a hydraulic cylinder and two brake shoes. The wheel cylinders' dual-piston design ensures an even distribution of force on each pair of brake shoes. Each brake cluster utilizes a leading-trailing design.

The rear-wheel, mechanical park brake system of the Pioneer 1200 vehicle utilizes a hand-activated park brake handle between the driver and passenger seats, a brake cable equalizer and two park brake cables. The brake clusters used on the rear wheels are identical to those used on the two front wheels with the addition of a lever and strut.

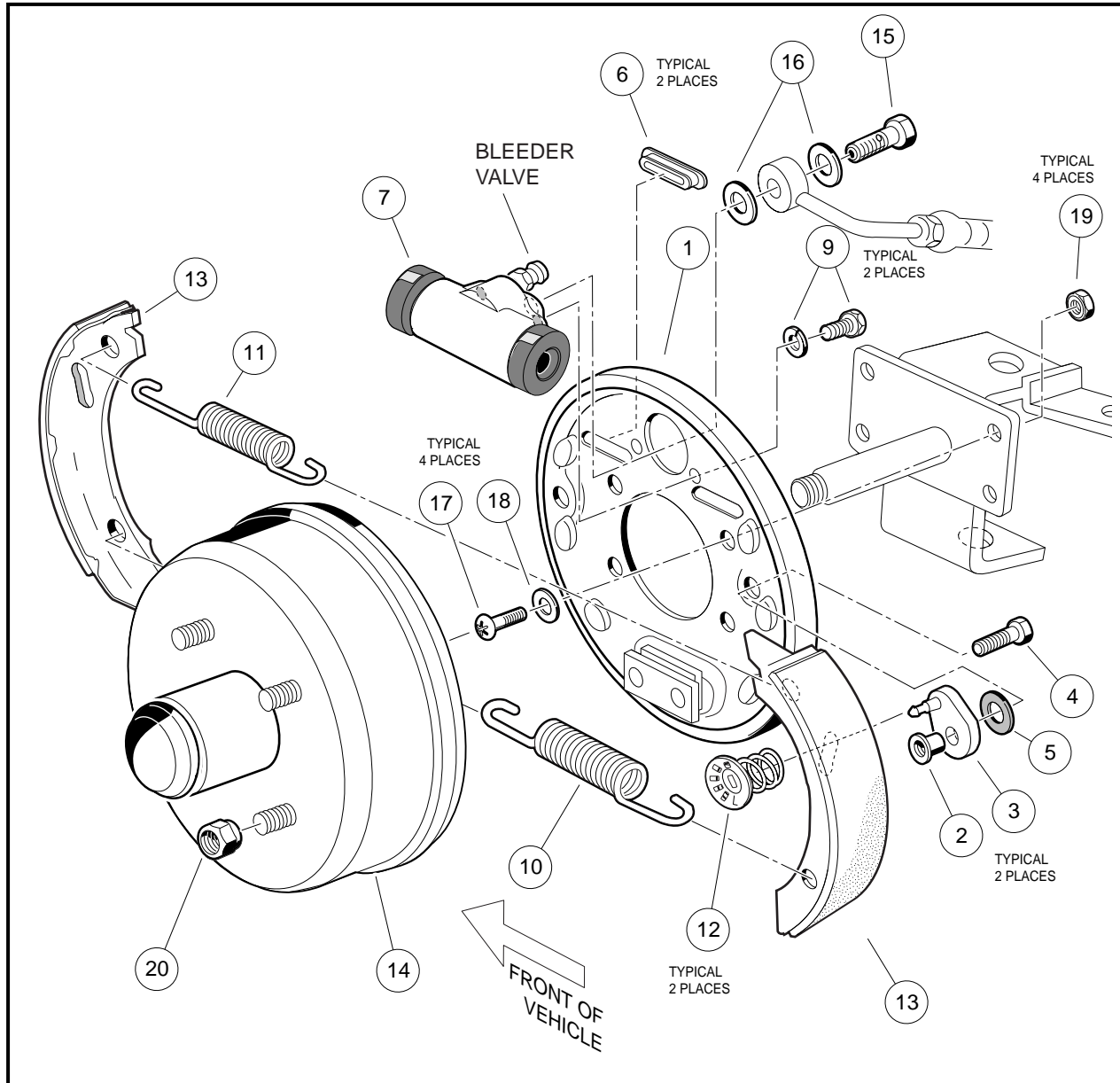

Figure 6-1 Front Hydraulic Brake Cluster Assembly

BRAKE SYSTEM INSPECTION

Read **WARNING** on page 6-1.

The hydraulic brake system and park brake system should be inspected immediately after any service to either of the brake systems.

Brake Pedal Inspection

- When driving the vehicle and pressing the brake pedal, the vehicle should come to a smooth, straight stop.
- Apply and release the brake pedal several times. If noise or binding occurs, the brake pedal or hydraulic brake system may be in need of service. Pedal movement should be smooth, and when the pedal is released, it should return quickly and quietly.

- Move the brake pedal from side to side to check for worn parts. Excessive side movement indicates worn pedal mounting parts. If worn parts are found, replace the worn parts, then adjust the brake pedal. **See Brake Pedal Adjustment, Section 5, Page 5-1.**
- Apply heavy pressure to the pedal and check for sponginess and excessive pedal travel. The pedal should be firm, and the back of the brake pedal should be a minimum of 2 inches from the floor. If the brake pedal feels “spongy”, perform the brake bleeding procedure. **See Bleeding the Hydraulic Brake System on page 6-29.**
- Hold the brake pedal depressed with medium foot pressure (25 to 35 lb.) for 15 seconds. The pedal should not continue dropping when pressed with a steady amount of pressure. If the pedal goes to the floor, inspect the hydraulic system for leaks and repair any worn or damaged components. After repair, bleed the hydraulic brake system. **See Bleeding the Hydraulic Brake System on page 6-29.**

Master Cylinder Inspection

- Inspect the exterior of the master cylinder. The presence of brake fluid on the exterior of the master cylinder indicates a brake fluid leak. Replace any leaking components and bleed the hydraulic brake system. **See Bleeding the Hydraulic Brake System on page 6-29.**
- Check the brake fluid level. **See Brake Fluid, Section 10, Page 10-6.**
- Remove the reservoir cap and inspect the brake fluid. The brake fluid should be clean with no residue in the bottom of the reservoir or any other evidence of contamination. If brake fluid is contaminated, purge the brake fluid and refill the hydraulic system. **See Purging the Hydraulic System on page 6-30. Also See Filling the Hydraulic System on page 6-31.**
- Check the vent holes in the reservoir cap. The vent holes should be clean and open. If the vent holes are not clean and open, clean or replace the cap.
- Check the diaphragm inside the reservoir cap. The diaphragm should not have holes or other damage. If the diaphragm is damaged, replace it before placing the vehicle in service.

Brake Line and Hose Inspection

- Inspect the brake lines. The brake lines should not be kinked, dented or damaged in any way. There should be no leakage from the brake lines or fittings. If a leak is discovered, replace the brake line. **See Hydraulic Line and Hose Replacement on page 6-24.**
- Inspect the brake hoses at the front wheels. When turning the steering wheel all the way from left to right and back again, the hoses should not come in contact with any component, especially the wheels or tires.
- Inspect the brake hoses. Hoses must be flexible and free from leaks, cuts, cracks or bulges. If the hoses do not pass inspection, replace as necessary. **See Hydraulic Line and Hose Replacement on page 6-24.**
- Check the back side of each brake cluster backing plate. The backing plates should be free from brake fluid and grease. If a brake hose or wheel cylinder shows signs of leaking, determine the cause of the leak and replace the brake hose or wheel cylinder. **See Wheel Cylinder Replacement on page 6-19. Also See Hydraulic Line and Hose Replacement on page 6-24.**

Park Brake Inspection

- Apply moderate pressure to the park brake handle. Tension should increase as the handle is pulled. When latched, the park brake should lock the wheels and hold the vehicle stationary (on incline of 20% or less). If the park brake does not function as described, adjust the park brake. **See Park Brake Adjustment on page 6-34.**
- Check the park brake cables, equalizer and linkage. The cables should not be corroded, frayed or damaged and should move freely within the cable sheathing. The cables should not come in contact with either of the rear wheels or tires.

Brake Drum and Shoe Inspection

- Remove and inspect each brake drum. The drum should not be cracked or warped, or have excessive scores or heat checks.
- Inspect the brake shoes. Shoes should not be distorted, cracked or have broken welds.
- Check the condition of the brake shoe linings. The brake shoe lining should not be glazed or soiled with grease or brake fluid. There should be a minimum of 1/32 inch (0.8 mm) of usable lining remaining at the thinnest point.

Brake Cluster Inspection

- Check each wheel cylinder (7) by pulling back the edge of each dust boot (**Figure 6-1, Page 6-2**) or (**Figure 6-18, Page 6-20**). There should be no accumulation of brake fluid in the boot. Brake fluid in the boot indicates a leaking wheel cylinder. If there is fluid in the boot, replace the wheel cylinder. **See Wheel Cylinder Replacement on page 6-19.**
- Inspect the shoe hold-down parts and springs. Shoe hold-down pins, springs and cups must be properly installed and not damaged.
- Inspect the automatic brake adjuster parts. If the adjusters (3) are frozen (requiring more than 65 in-lb (7.4 N-m) to turn freely), worn or loose, replace the adjuster assemblies in pairs (**Figure 6-1, Page 6-2**).

BRAKE SYSTEM TROUBLESHOOTING

With normal scheduled maintenance and replacement of worn parts, the hydraulic and park brake systems should provide trouble-free operation. In the event that a problem does occur, the following troubleshooting guide will be helpful in identifying operating difficulties. The guide includes the symptom, probable cause(s) and suggested checks. The procedures used in making these checks can be found in the referenced sections of this Maintenance and Service Manual.

SYMPTOM	POSSIBLE CAUSE(S)	CORRECTIVE ACTION
Low pedal – Pedal may go to the floor	Excessive clearance between the drums and shoe linings	Front - Perform Step 19 of Front Wheel Brake Drum Installation on page 6-14. Rear - Perform Step 3 of Rear Wheel Brake Drum Installation on page 6-16.
	Automatic adjusters are not working	Make several forward and reverse brake stops; if the pedal does not come up, replace the automatic adjusters. See Brake Shoe Adjuster Replacement on page 6-21.
	Bent or distorted brake shoes	Replace the brake shoes. See Brake Shoe Removal on page 6-9.
	Leak in the hydraulic system	Check the master cylinder, brake lines and hoses for leaks. Replace all damaged parts.
	Air in the hydraulic system	See Bleeding the Hydraulic Brake System on page 6-29.
	Weak (bulging) brake hose	Replace the worn hose. See Hydraulic Line and Hose Replacement on page 6-24.
	Improperly adjusted master cylinder push rod	See Brake Pedal Adjustment on page 5-1.
Troubleshooting Guide continued on next page...		

SYMPTOM	POSSIBLE CAUSE(S)	CORRECTIVE ACTION
Springy or spongy brake pedal – Brake pedal has soft, springy or spongy feel when depressed	Bent or distorted brake shoes	Replace the brake shoes. See Brake Shoe Removal on page 6-9.
	Cracked or thin drums	Replace brake drums. See Brake Drum Removal on page 6-7.
	Poor quality brake fluid (low boiling point)	Purge hydraulic fluid and fill with approved DOT 5 (silicone) brake fluid. See Purging the Hydraulic System on page 6-30.
	Weak (bulging) brake hoses that expand under pressure	Check the master cylinder, brake lines and hoses for leaks or bulges. Replace all damaged parts.
	Air in the hydraulic system	See Bleeding the Hydraulic Brake System on page 6-29.
Hard pedal – Excessive pedal pressure is required to stop the vehicle	Brake fade	Replace the brake shoes. See Brake Shoe Removal on page 6-9.
	Grease or brake fluid on the brake shoe linings	Replace hub or axle seal and replace the brake shoes. See Brake Shoe Removal on page 6-9.
	Glazed brake shoe linings	Replace the brake shoes. See Brake Shoe Removal on page 6-9.
	Damaged or distorted brake shoes	Replace the brake shoes. See Brake Shoe Removal on page 6-9.
	Scored or barrel-shaped brake shoe drums	Replace the brake drums. See Brake Drum Removal on page 6-7.
	Clogged master cylinder lines or hoses	Replace brake lines or hoses as required. See Hydraulic Line and Hose Replacement on page 6-24.
	Frozen master cylinder piston	Replace master cylinder. See Master Cylinder Removal on page 6-28.
Over-aggressive braking	Incorrect or distorted brake shoes	Replace the brake shoes. See Brake Shoe Removal on page 6-9.
	Grease or brake fluid on the brake shoe linings	Replace hub, axle seal or wheel brake cylinder and replace brake shoes. See Brake Shoe Removal on page 6-9.
	Loose or distorted brake backing plate	Tighten or replace the backing plate and/or hardware.
	Scored or warped brake drums	Replace the brake drums. See Brake Drum Removal on page 6-7.
	Corroded master cylinder bore	Replace master cylinder. See Master Cylinder Removal on page 6-28.
	Binding brake pedal linkage	Lubricate and adjust. See Section 5 of this Maintenance and Service Manual.
Vehicle pulls to one side	Incorrect or distorted brake shoes	Replace the brake shoes. See Brake Shoe Removal on page 6-9.
	Grease or brake fluid on the brake shoe linings	Replace hub, axle seal or wheel cylinder and replace the brake shoes. See Brake Shoe Removal on page 6-9.
	Loose or distorted brake cluster backing plate	Tighten or replace the backing plate and/or hardware.
	Scored or warped brake drums	Replace the brake drums. See Brake Drum Removal on page 6-7.
Troubleshooting Guide continued on next page...		

SYMPTOM	POSSIBLE CAUSE(S)	CORRECTIVE ACTION
Vehicle pulls to one side, Continued	Water on the brake shoe linings	Apply the brakes several times to dry the brake shoe linings.
	Sticking wheel cylinder piston	Replace the wheel cylinder. See Wheel Cylinder Replacement on page 6-19.
	Faulty suspension parts	See Section Section 7 – Steering and Front Suspension or Section 9 – Rear Suspension.
Pulsating brake pedal	Warped brake drums	Replace the brake drums. See Brake Drum Removal on page 6-7.
	Bent axle	Replace the axle. See Section 16 – Unitized Transaxle with Differential Lock.
	Worn or damaged front wheel bearings	Replace bearings. See Section 7 – Steering and Front Suspension.
Noise and chatter – Squealing, clicking or scraping sound upon brake application	Bent, damaged or incorrect brake shoes	Replace the brake shoes. See Brake Shoe Removal on page 6-9.
	Worn out brake shoes	Replace the brake shoes. See Brake Shoe Removal on page 6-9.
	Foreign material embedded in brake shoe linings	Replace the brake shoes. See Brake Shoe Removal on page 6-9.
	Broken brake shoe return springs or hold down springs	Replace damaged parts.
	Rough, grooved or dry brake shoe ledges or backing plate bosses	Lubricate the bosses of the brake cluster backing plate, and/or replace the brake shoes. See Brake Cluster Assembly Inspection and Cleaning on page 6-10 and/or Brake Shoe Removal on page 6-9.
	Brake drums are cracked or scored	Replace the brake drums. See Brake Drum Removal on page 6-7.
Decreasing brake pedal travel	Weak or broken brake shoe return springs	Replace return springs.
	Sticking wheel cylinder piston	Replace the wheel cylinder. See Wheel Cylinder Replacement on page 6-19.
	Overly adjusted brake adjusters	Adjust brake adjusters. See Brake Shoe Adjuster Replacement on page 6-21.
	Improperly adjusted park brake	Adjust park brake. See Park Brake Adjustment on page 6-34.
All brakes drag	Binding brake pedal	Lubricate and adjust. See Section 5 of this Maintenance and Service Manual.
	Soft or swollen rubber parts caused by incorrect or contaminated brake fluid	Replace master cylinder. See Master Cylinder Removal on page 6-28.
Rear brakes drag	Binding park brake cables	Adjust or replace cables and adjust.
	Improper brake adjustment	Adjust shoes and repair the brake shoe adjusters if necessary. See Brake Cluster Assembly Inspection and Cleaning on page 6-10.
One brake drags	Weak or broken brake shoe return springs	Replace the return springs.
	Sticking wheel cylinder pistons	Replace the wheel cylinder. See Wheel Cylinder Replacement on page 6-19.
	Loose or worn front wheel bearings	Adjust or replace front wheel bearings. See Section 7 – Steering and Front Suspension.
Troubleshooting Guide continued on next page...		

SYMPTOM	POSSIBLE CAUSE(S)	CORRECTIVE ACTION
One brake drags, Continued	Improper brake shoe adjustment	Adjust shoes and repair the brake shoe adjusters if necessary. See Brake Cluster Assembly Inspection and Cleaning on page 6-10.
	Swollen wheel cylinder cups	Replace the wheel cylinder and purge the hydraulic system. See Wheel Cylinder Replacement on page 6-19. See Purging the Hydraulic System on page 6-30.
	Bent or distorted brake shoes	Replace the brake shoes. See Brake Shoe Removal on page 6-9.
	Damaged brake line or hydraulic line	Replace brake lines or tubes as required. See Hydraulic Line and Hose Replacement on page 6-24.

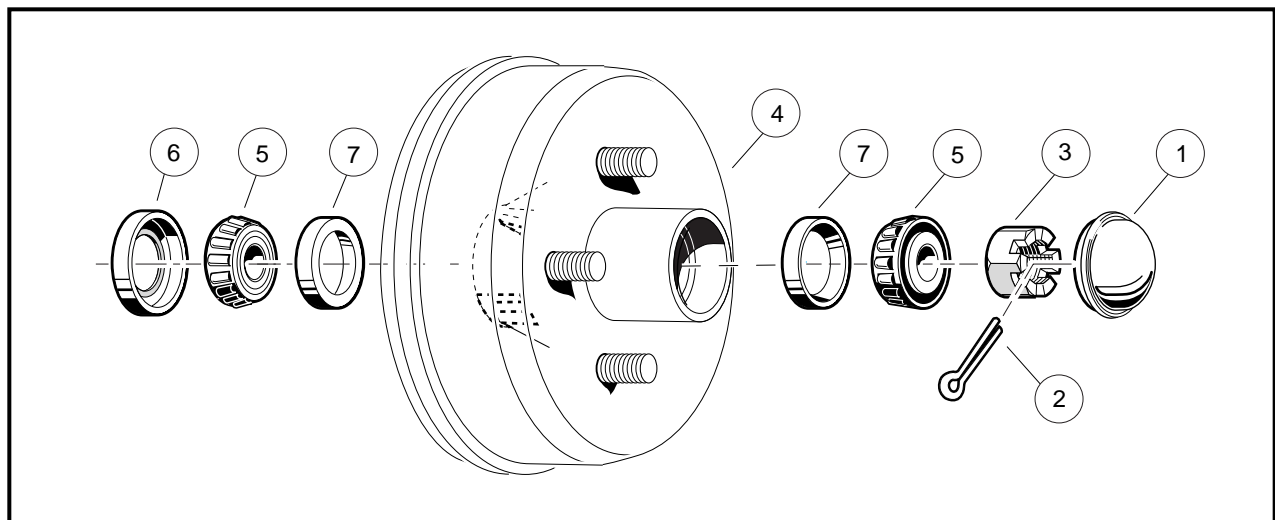

Figure 6-2 Front Spindle and Brake Drum Assembly

BRAKE DRUM REMOVAL

Read **WARNING** on page 6-1.

FRONT WHEEL BRAKE DRUM REMOVAL

▲ WARNING

- If at any point in this procedure the hydraulic system is opened, the brakes must be bled after the correct reinstallation of the brake components. Failure to bleed the brakes could result in decreased braking performance due to air being trapped in the hydraulic system. Use only DOT 5 brake fluid. **See Bleeding the Hydraulic Brake System on page 6-29.**
1. To remove the front brake drums, place chocks at the rear wheels, release the park brake, loosen the front wheel lug nuts and lift the front of the vehicle with a chain hoist or floor jack. Place jack stands under the front frame tubes to support the vehicle and lower the floor jack or chain hoist so that the vehicle is resting on the jack stands.
 2. Remove the lug nuts and remove the front wheel.

Front Wheel Brake Drum Removal, Continued:

3. Remove the dust cover (1) (**Figure 6-2, Page 6-7**).
4. Remove the cotter pin (2) (**Figure 6-2, Page 6-7**).
5. Remove the castle nut (3), wheel bearing (5) and drum (4) (**Figure 6-2, Page 6-7**).
6. If the brake drum was easily removed, proceed to step 8. **See following NOTE.**

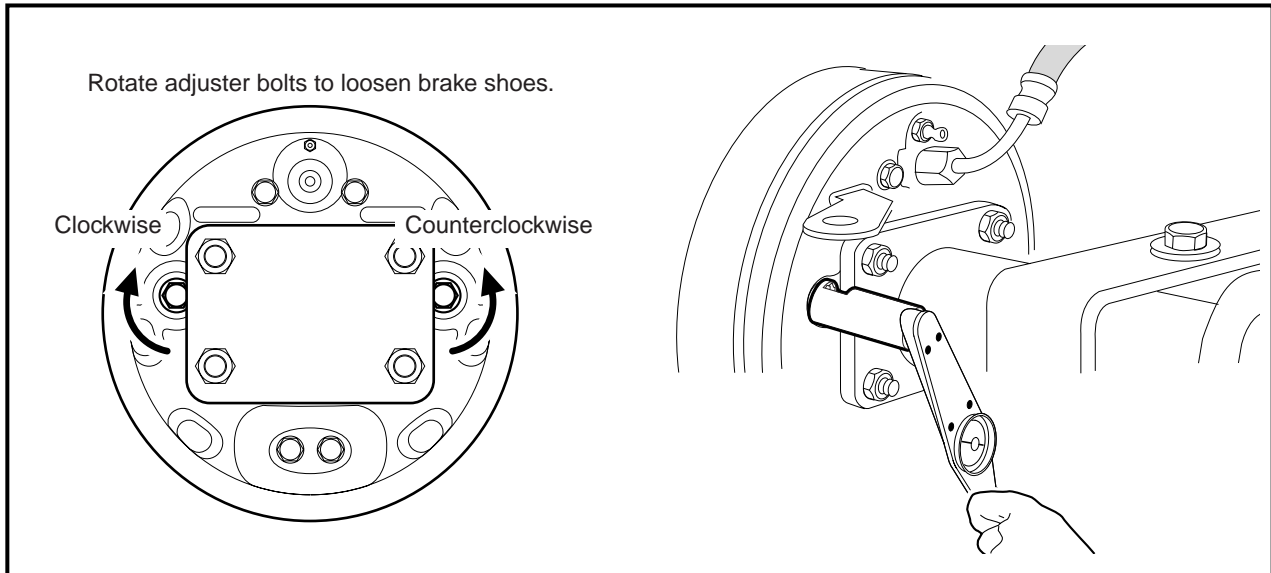
**Figure 6-3 Loosen Brake Shoe Adjuster**

NOTE: If the brake drum cannot be easily removed, loosen the brake cluster adjusters to increase the clearance between the brake shoe linings and the brake drum (**Figure 6-3, Page 6-8**).

7. Removing tight brake drums:
 - 7.1. On the back of each brake cluster assembly, locate the heads of the two brake shoe adjusters.
 - 7.2. Using a torque wrench and hydraulic brake adjuster (CCI 102169401), gently rotate the adjuster bolt in order to increase the clearance between the brake shoe lining and the brake shoe drum (**Figure 6-3, Page 6-8**).
8. Repeat steps 1 through 7 for the opposite front wheel if necessary.

REAR WHEEL BRAKE DRUM REMOVAL

1. To remove the rear brake drums, place chocks at the front wheels, release the park brake, loosen the rear wheel lug nuts and lift the rear of the vehicle with a chain hoist or floor jack. Place jack stands under the axle tubes to support the vehicle and lower the floor jack or chain hoist so that the vehicle is resting on the jack stands.
2. Remove the lug nuts and remove the rear wheel.
3. Remove the brake drum. If the brake drum was easily removed, proceed to step 5. **See following NOTE.**

NOTE: If the brake drum cannot be easily removed, loosen the brake cluster adjusters to increase the clearance between the brake shoe linings and the brake drum (**Figure 6-3, Page 6-8**).

4. Removing tight brake drums:
 - 4.1. On the back of each brake cluster assembly, locate the heads of the two brake shoe adjusters.

- 4.2. Using a torque wrench and hydraulic brake adjuster (CCI 102169401), gently rotate the adjuster bolt in order to increase the clearance between the brake shoe lining and the brake shoe drum (**Figure 6-3, Page 6-8**).
5. Repeat steps 1 through 4 for the opposite rear wheel if necessary.

BRAKE SHOE REMOVAL

Read **WARNING** on page 6-1.

▲ WARNING

- If at any point in this procedure the hydraulic system is opened, the brakes must be bled after the correct reinstallation of the brake components. Failure to bleed the brakes could result in decreased braking performance due to air being trapped in the hydraulic system. Use only DOT 5 brake fluid. See **Bleeding the Hydraulic Brake System** on page 6-29.
1. Brake drum removal is necessary prior to removing the brake shoes. **See Brake Drum Removal on page 6-7.**
 2. Remove the rear axle to remove **rear** brake shoes. To remove the **front** brake shoes, proceed to step 3.
 - 2.1. Using 90° internal snap ring pliers (.090 tip) (CCI 1012560), remove internal retaining ring from axle tube (**Figure 6-4, Page 6-9**).
 - 2.2. Carefully pull the axle shaft straight out of the axle tube.
 - 2.3. Repeat steps 2.1 and 2.2 for the opposite rear wheel if necessary.

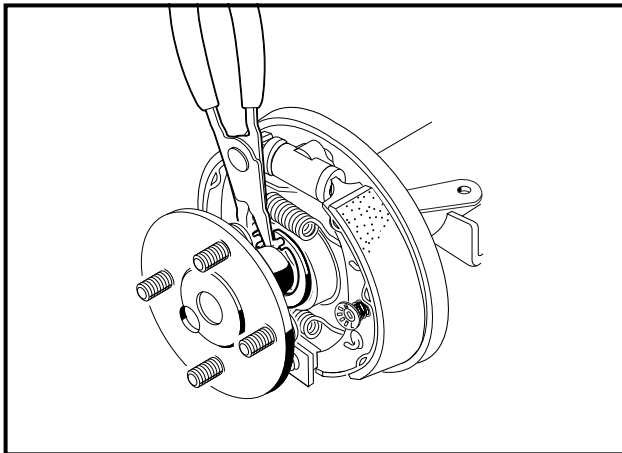

Figure 6-4 Remove Axle Retaining Ring

3. Using pliers or a brake tool, rotate the cup and spring assembly 90° and remove the cup and spring from each brake shoe (**Figure 6-5, Page 6-10**).

NOTE: The brake shoes are under spring pressure and can release suddenly when cup and spring assemblies are removed.

4. Grasp both brake shoes and pull them, with the springs, out of brake cluster assembly (**Figure 6-6, Page 6-10**).

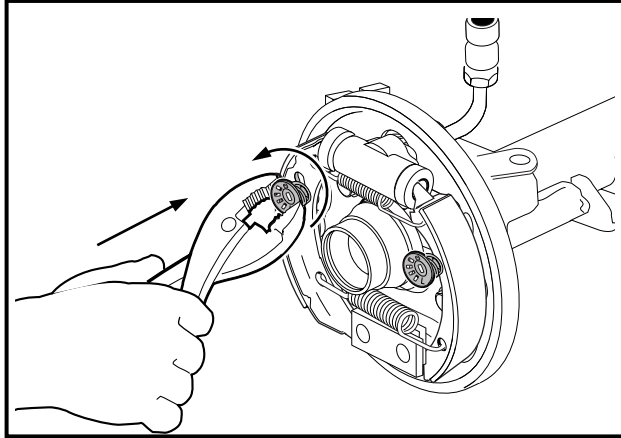

Figure 6-5 Rotate Cup and Spring Assembly

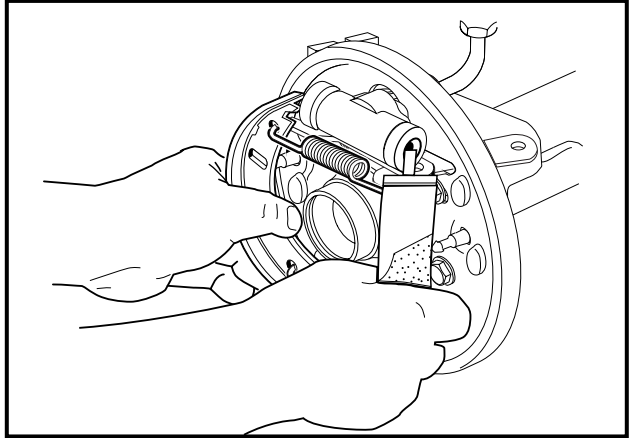

Figure 6-6 Remove Brake Shoes

BRAKE CLUSTER ASSEMBLY INSPECTION AND CLEANING

Read **WARNING** on page 6-1.

⚠ WARNING

- If at any point in this procedure the hydraulic system is opened, the brakes must be bled after the correct reinstallation of the brake components. Failure to bleed the brakes could result in decreased braking performance due to air being trapped in the hydraulic system. Use only DOT 5 brake fluid. See **Bleeding the Hydraulic Brake System** on page 6-29.

NOTE: Factory installed brake shoes on the Pioneer 1200 have non-asbestos linings. When replacing brake shoes, Club Car recommends non-asbestos replacement parts.

1. Remove the brake drum and brake shoes. **See Brake Drum Removal on page 6-7 and Brake Shoe Removal on page 6-9.**
2. Clean the brake cluster backing plate and all of the brake cluster components.
3. Check the brake shoe adjusters in each brake cluster assembly for proper operation.
 - 3.1. With the brake drum removed, gently rotate the adjusters with a torque wrench and hydraulic brake adjuster (CCI 102169401). If the adjusters require more than 65 in-lb (7.3 N·m) of force to rotate, they must be replaced.
4. Check the wheel cylinder for signs of leakage. If there are signs of leakage, replace the wheel cylinder. **See Wheel Cylinder Replacement on page 6-19.**
5. Check all springs for loss of tension and damage. Replace weak springs and any damaged or badly worn parts.
6. For the rear brake clusters, ensure that the park brake lever and strut assembly (14) can be easily moved by hand (**Figure 6-18, Page 6-20**). If the assembly can be easily moved by hand, proceed to step 7. If the assembly cannot be easily removed by hand, cleaning and lubrication will be necessary.
 - 6.1. Remove the park brake cable pin (2) and clevis (3) from the lever and strut (**Figure 6-15, Page 6-18**).
 - 6.2. Remove the lever and strut (14) from the brake cluster assembly (**Figure 6-18, Page 6-20**).

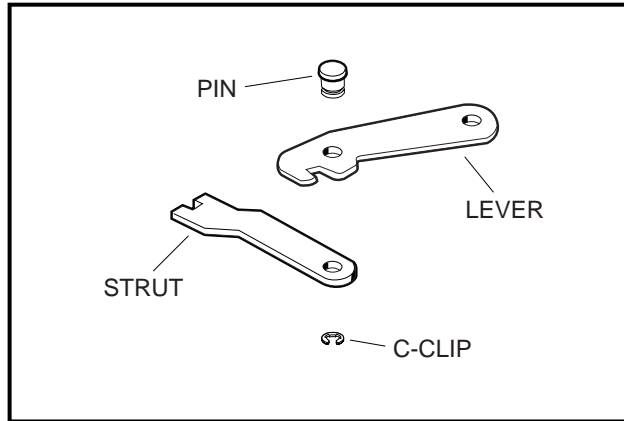

Figure 6-7 Park Brake Lever and Strut

- 6.3. Disassemble the lever and strut by removing the c-clip and pin (**Figure 6-7, Page 6-11**).
- 6.4. Using a wire brush, remove corrosion and contaminants from the contact areas of the strut and lever.
- 6.5. Using NLGI Number 2 white lithium grease, lightly lubricate the pin and contact surfaces and reassemble the lever and strut. **See following WARNING.**

⚠ WARNING

- **Make sure the C-clip is properly seated in the groove of the pin. An improperly installed C-clip could result in a non-functioning park brake.**
- **Apply grease carefully when performing the following steps. Do not allow any grease to get on the friction surfaces of the brake shoe pads. Failure to heed this warning could cause diminished brake performance, possibly resulting in property damage or severe personal injury.**

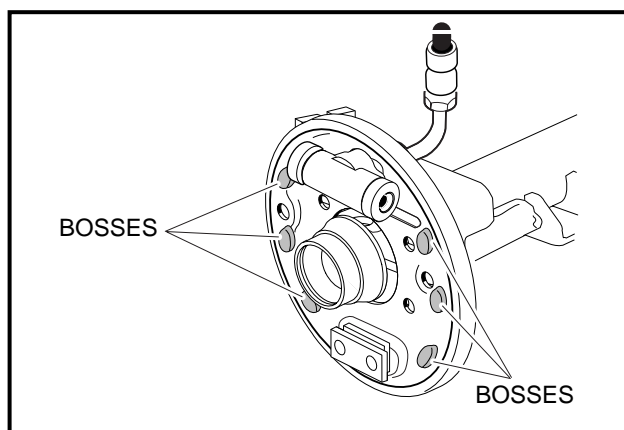

Figure 6-8 Lubricate Raised Bosses

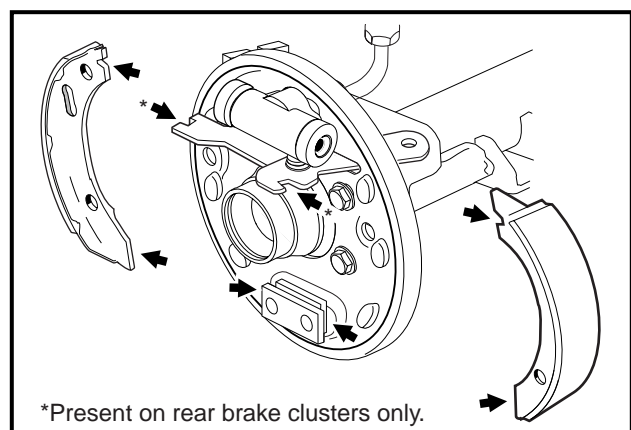

Figure 6-9 Lubricate Brake Cluster

7. Use a small brush to carefully apply a liberal amount of white lithium NLGI Number 2 grease (Dow Corning BR2-Plus or equivalent) on each of the six raised bosses on the brake cluster backing plate (**Figure 6-8, Page 6-11**). **See preceding WARNING.**

8. Use a small brush to carefully apply a liberal amount of white lithium NLGI Number 2 grease (Dow Corning BR2-Plus or equivalent) to each end of both brake shoes and into the slots in the brake shoe mounting block as shown. For rear brake clusters, apply grease to the notches in the mechanical park brake mechanism as shown (**Figure 6-9, Page 6-11**). See preceding **WARNING**.
9. Repeat steps 1 through 8 for the remaining brake cluster assemblies if necessary.

BRAKE SHOE INSTALLATION

Read **WARNING** on page 6-1.

⚠ WARNING

- If at any point in this procedure the hydraulic system is opened, the brakes must be bled after the correct reinstallation of the brake components. Failure to bleed the brakes could result in decreased braking performance due to air being trapped in the hydraulic system. Use only DOT 5 brake fluid. See **Bleeding the Hydraulic Brake System** on page 6-29.

NOTE: Unlike some other brake systems, the Pioneer 1200 vehicle uses a pair of identical brake shoes in each brake cluster. While a brake shoe may be installed on either the left-hand or right-hand side of the brake cluster assembly, the shoe must be positioned so that the adjuster pin is inserted into the slot of the brake shoe as illustrated (**Figure 6-1, Page 6-2** or **Figure 6-18, Page 6-20**).

1. Install the front brake shoe onto the brake cluster backing plate.
2. Install the cup and spring assembly (12) onto the pin of the adjuster (3)(**Figure 6-1, Page 6-2**). Compress the cup with a pair of pliers or a brake tool and rotate 90°, securing the brake shoe to the brake cluster backing plate (**Figure 6-5, Page 6-10**).

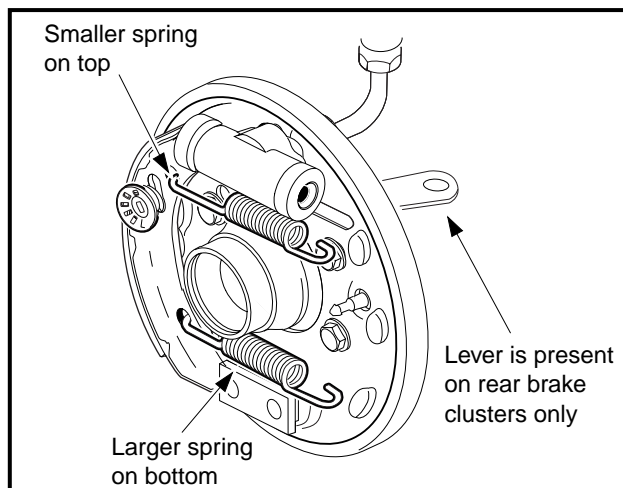

Figure 6-10 Brake Shoe Springs

3. Attach the springs onto the shoe already installed (**Figure 6-10, Page 6-12**), then hold the rear shoe next to the front shoe, correctly oriented, and attach the springs (10 and 11) to the shoe as illustrated (**Figure 6-1, Page 6-2** or **Figure 6-18, Page 6-20**).

4. While maintaining spring attachment on both shoes, position the bottom tip of the rear shoe into the brake shoe mounting block and the top tip of the shoe into the slot in the wheel cylinder piston. Push the shoe into place. Hold shoe in position and install the cup and spring (**Figure 6-11, Page 6-13**). For rear brake shoes only, align the notches in the brake shoes (13) (**Figure 6-18, Page 6-20**) with the notches in the park brake lever assembly (14) as illustrated. Gently press the lever (14) at the back of the brake cluster to ensure that it is seated correctly between the brake shoes.

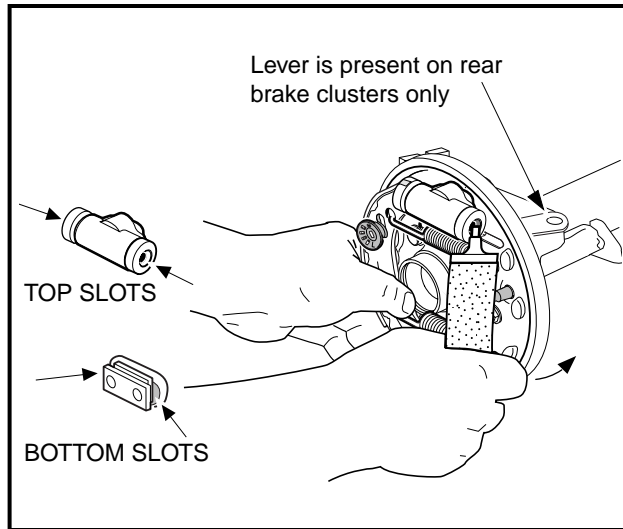

Figure 6-11 Shoe Installation

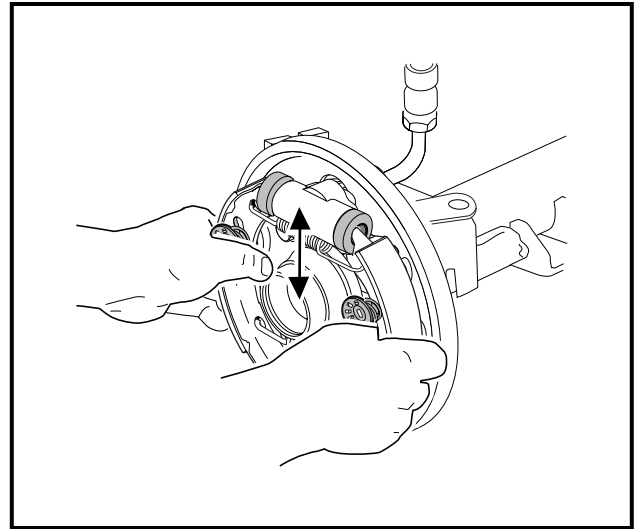

Figure 6-12 Slide Shoes

5. After the shoes are installed, move them together up and down to make sure that they will easily slide approximately 1/4 to 3/8 inch (6.3 to 9.5 mm) without binding (**Figure 6-12, Page 6-13**).
6. Repeat steps 1 through 5 for the remaining wheels if necessary.
7. Proceed to **Brake Drum Installation on page 6-14**.
8. Install rear axle if required.

NOTE: Clean any residual oil from the exposed end of the axle shaft and from the oil seal area prior to installing the axle shaft.

- 8.1. Clean the axle shaft and splines and then insert the shaft, splined end first, through the seal and into the axle tube. Be careful not to damage the seal. Advance the shaft through the inner bearing and rotate it to align the shaft splines with the splined bore of the differential side gear. Continue advancing the shaft until the bearing seats against the axle tube shoulder.
- 8.2. Install retaining ring in the axle tube (**Figure 6-4, Page 6-9**).
- 8.3. Place a 1/4 to 3/8 inch (6-10 mm) diameter rod against the retaining ring and tap lightly at four to five locations to ensure it is properly seated. **See following WARNING.**

⚠ WARNING

- Be sure retaining ring is properly seated in its groove. If ring is not properly installed, the axle assembly will separate from the transaxle and damage the axle assembly and other components. Loss of vehicle control could result in severe personal injury or death.

BRAKE DRUM INSTALLATION

Read **WARNING** on page 6-1.

⚠ WARNING

- If at any point in this procedure the hydraulic system is opened, the brakes must be bled after the correct reinstallation of the brake components. Failure to bleed the brakes could result in decreased braking performance due to air being trapped in the hydraulic system. Use only DOT 5 brake fluid. See **Bleeding the Hydraulic Brake System** on page 6-29.
- Worn or damaged brake drums cannot be machined. Replace as necessary.

FRONT WHEEL BRAKE DRUM INSTALLATION

NOTE: Prior to installing the brake drum, inspect the brake lines, hoses, drums and brake cluster assemblies. See **Brake System Inspection** on page 6-2.

Clean any residual grease from the friction area of the brake drum prior to installing it.

1. Inspect the wheel bearings for damage or wear. Replace bearings and cups if necessary.
2. Clean the wheel bearings (5), making sure that there is no dirt or debris trapped in the rollers (**Figure 6-2, Page 6-7**).

NOTE: Do not use compressed air to dry wheel bearings after cleaning.

3. Inspect the bearing cups (7) for wear or damage. If they are worn or pitted, remove the cups by inserting a drift punch from the opposite end of the hub and tapping lightly around them (**Figure 6-2, Page 6-7**).
4. If bearing cups (7) were removed, press new cups in squarely against the shoulder in the hub (**Figure 6-2, Page 6-7**).

NOTE: Always install new cups (7) when new bearings (5) are installed (**Figure 6-2, Page 6-7**).

5. Inspect the surface of the spindle shaft where the seal (6) seats. It should be clean and smooth (**Figure 6-2, Page 6-7**).
6. Pack the wheel bearings (5) and lubricate the bearing cups (7) with Chassis Lube (EP NLGI Grade 2). Make sure the grease is forced between the rollers (**Figure 6-2, Page 6-7**).
7. Install a new seal (6) and wheel bearing (5) into rear of hub (**Figure 6-2, Page 6-7**).
8. Lubricate spindle shaft with grease.
9. Carefully apply grease around seal (6) inner lip before installation. Do not allow grease to touch the brake shoe linings or the brake shoe surface of the drum/hub.
10. Place the drum/hub (14) onto the spindle and brake cluster (**Figure 6-1, Page 6-2**). See following **NOTE**.

NOTE: If drum installation is difficult:

The brake shoes may need to be adjusted vertically in the mounting slots.

Rotation of the brake shoe adjusters may be necessary to create additional clearance between the brake shoes and the brake drum (**Figure 6-3, Page 6-8**). Use a hydraulic brake adjuster (CCI 102169401) to gently rotate the adjusters.

11. Fill cavity with grease.

12. Install the outside bearing (5) on the spindle (**Figure 6-2, Page 6-7**).
13. Install the castle nut (3) onto the spindle finger-tight (**Figure 6-2, Page 6-7**).
14. Rotate while gently pressing the brake drum to ensure that the drum is properly seated.
15. Tighten the castle nut (3) to 30 ft-lb (13.6 N·m), in order to fully seat the bearing and cup.
16. Loosen the castle nut 1/2 turn and immediately retighten the nut to 14 in-lb (1.6 N·m).
17. Install a **new** cotter pin (2), bending the pin to secure the castle nut (**Figure 6-2, Page 6-7**). **See following WARNING, CAUTION and NOTE.**

▲ WARNING

- **Make sure to install and bend the cotter pin. Failure to bend the cotter pin could result in the separation of the wheel from the spindle. Loss of vehicle control could result, causing severe personal injury.**

▲ CAUTION

- *Use a new cotter pin when installing the drum/hub assembly.*

NOTE: If the cotter pin does not line up with the hole in the spindle when the castle nut is properly tightened, rotate the castle nut back until the next available notch allows the cotter pin to be installed.

18. Install the dust cover (1) (**Figure 6-2, Page 6-7**).
19. With the brake drum properly seated and secured, gently adjust the clearance between the brake shoes and brake drum by turning each of the two adjusters on the brake cluster as shown (**Figure 6-13, Page 6-16**). Use a hydraulic brake adjuster (CCI 102169401) and torque wrench. **See following CAUTION.**

▲ CAUTION

- *Do not apply more than 65 in-lb (7.3 N·m) of torque to any of the adjuster bolts. Over-tightening the adjuster bolts could result in damage to the brake cluster components or the separation of the bolt (4) from the adjuster (3) (**Figure 6-1, Page 6-2 or Figure 6-18, Page 6-20**).*

20. Install the wheel and finger-tighten the lug nuts.
21. Repeat steps 1 through 20 for the opposite front wheel as required.
22. Lower the vehicle and finish tightening the lug nuts (using a crisscross pattern) to 55 ft-lb (74.6 N·m).
23. Perform all of the brake system inspections to ensure that both the hydraulic brake system and the park brake system are adjusted correctly and are operating correctly before placing the vehicle into service. **See Brake System Inspection on page 6-2.**
24. Check the front wheel free play. **See Front Wheel Free Play Inspection, Section 7, Page 7-20.**

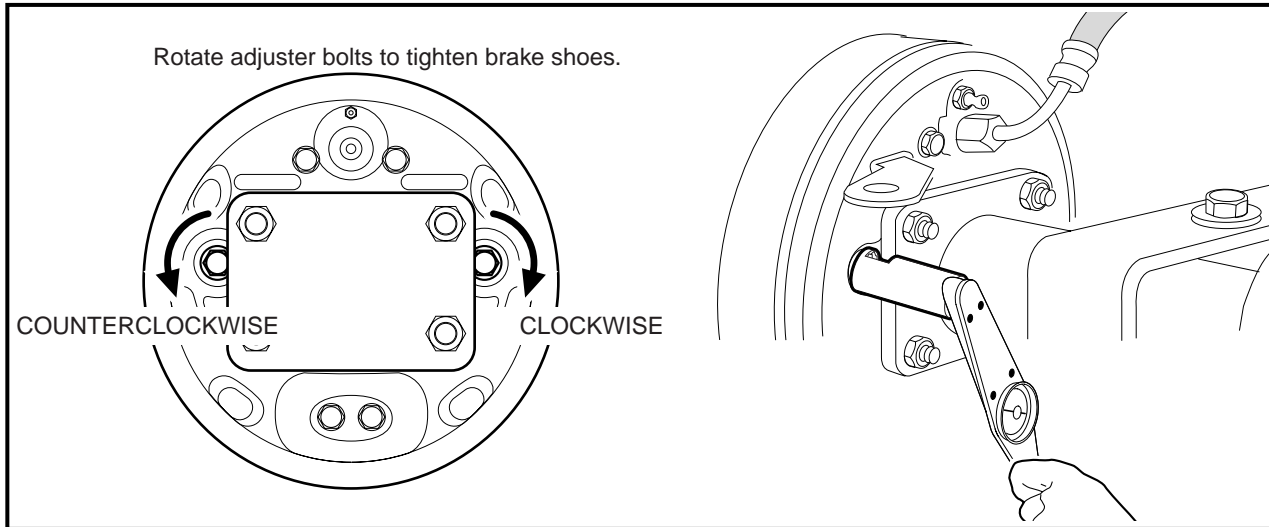

Figure 6-13 Tighten Brake Shoe Adjusters

REAR WHEEL BRAKE DRUM INSTALLATION

NOTE: Prior to installing the brake drum, inspect the brake lines, hoses, drums and brake cluster assemblies. **See Brake System Inspection on page 6-2.**

1. Place the drum (15) onto the axle and brake cluster (**Figure 6-18, Page 6-20**).

NOTE: If drum installation is difficult;

The brake shoes may need to be adjusted vertically in the mounting slots.

Rotation of the brake shoe adjusters may be necessary to create additional clearance between the brake shoes and the brake drum (**Figure 6-3, Page 6-8**). Use a hydraulic brake adjuster (CCI 102169401) and torque wrench to gently rotate the adjusters.

2. Rotate and gently press the brake drum to ensure that the drum is properly seated.
3. With the brake drum properly seated, gently adjust the clearance between the brake shoes and brake drum by turning each of the two adjusters on the brake cluster as shown (**Figure 6-13, Page 6-16**). Use a hydraulic brake adjuster (CCI 102169401) and torque wrench. **See following CAUTION.**

⚠ CAUTION

- Do not apply more than 65 in-lb (7.3 N-m) of torque to any of the adjuster bolts. Over-tightening the adjuster bolts could result in damage to the brake cluster components or the separation of the bolt (4) from the adjuster (3) (**Figure 6-1, Page 6-2 or Figure 6-18, Page 6-20**).
4. Install the wheel and finger-tighten the lug nuts.
 5. Repeat steps 1 through 4 for the opposite rear wheel as required.
 6. Lower the vehicle and finish tightening the lug nuts (using a crisscross pattern) to 55 ft-lb (74.6 N-m).
 7. Perform all of the brake system inspections to ensure that both the hydraulic brake system and the park brake system are adjusted and operating correctly before placing the vehicle into service. **See Brake System Inspection on page 6-2.**

BRAKE CLUSTER REPLACEMENT

Read **WARNING** on page 6-1.

▲ WARNING

- To perform this procedure, the hydraulic system must be opened. As a result, the brakes must be bled after the correct reinstallation of the brake components. Failure to bleed the brakes could result in decreased braking performance due to air being trapped in the hydraulic system. Use only DOT 5 brake fluid. See **Bleeding the Hydraulic Brake System** on page 6-29.
- Worn or damaged brake drums **MUST NOT** be machined. Replace as necessary.

FRONT BRAKE CLUSTER REMOVAL

1. Perform the procedure for brake drum removal. See **Brake Drum Removal** on page 6-7.
2. Remove the banjo bolt (15) and copper washers (16) from the brake cluster assembly. To avoid spilling brake fluid, lift the hose above the brake cluster assembly (**Figure 6-1, Page 6-2**).
3. To ensure that no dirt or debris enters the hydraulic braking system, place the hose fitting in a plastic bag and secure to the vehicle frame as shown (**Figure 6-14, Page 6-17**).

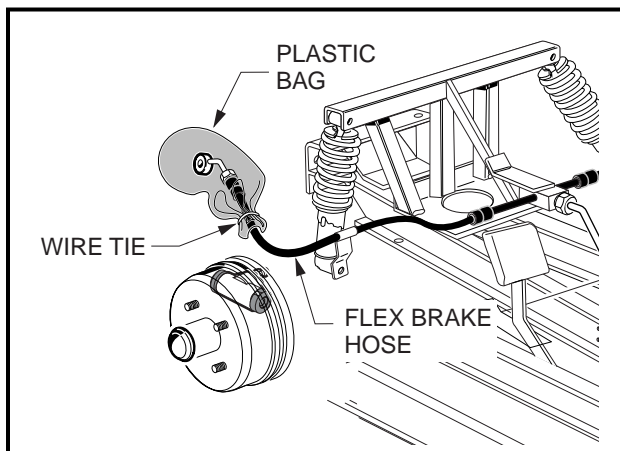

Figure 6-14 Front Brake Hose With Plastic Bag

4. Remove the four Torx head bolts (17), washers (18) and lock nuts (19) that secure the brake cluster to the spindle assembly (**Figure 6-1, Page 6-2**).

FRONT BRAKE CLUSTER INSTALLATION

1. Use only **new** hardware for this step. Install the brake cluster mounting plate to the spindle assembly with four Torx head bolts (17), washers (18) and lock nuts (19). Tighten all four bolts to 76 in-lb (8.6 N-m) (**Figure 6-1, Page 6-2**).
2. Connect the brake hose to the brake cluster assembly with two **new** copper washers (16) and the banjo bolt (15). Tighten the banjo bolt to 13 ft-lb (17.6 N-m) (**Figure 6-1, Page 6-2**).
3. Perform the procedure for front brake drum/hub installation. See **Front Wheel Brake Drum Installation** on page 6-14.
4. Bleed the front wheel brakes as instructed. See **Bleeding the Hydraulic Brake System** on page 6-29.

5. Perform all of the brake system inspections to ensure that both the hydraulic brake system and the park brake system are adjusted and operating correctly before placing the vehicle into service. **See Brake System Inspection on page 6-2.**

REAR BRAKE CLUSTER REMOVAL

1. Perform the procedure for brake drum removal. **See Rear Wheel Brake Drum Removal on page 6-8.**
2. Remove the rear axle to remove rear brake cluster.
 - 2.1. Using 90° internal snap ring pliers (.090 tip) (CCI 1012560), remove internal retaining ring from axle tube (**Figure 6-4, Page 6-9**).
 - 2.2. Carefully pull the axle shaft straight out of the axle tube.
 - 2.3. Repeat steps 2.1 through 2.2 for the opposite rear wheel if necessary.
3. Remove park brake cable clip (1), hair spring cotter pin (2) and clevis pin (3) (**Figure 6-15, Page 6-18**).
4. Remove the cable from the cable support bracket (**Figure 6-15, Page 6-18**) Using a 3/8 inch **flare nut wrench**, remove the brake hose from the rear brake cluster. To avoid spilling brake fluid, lift the hose above the brake cluster assembly (**Figure 6-16, Page 6-18**).
5. To ensure that no debris enters the hydraulic system, place the hose fitting in a plastic bag and secure to the vehicle frame as shown (**Figure 6-17, Page 6-18**).

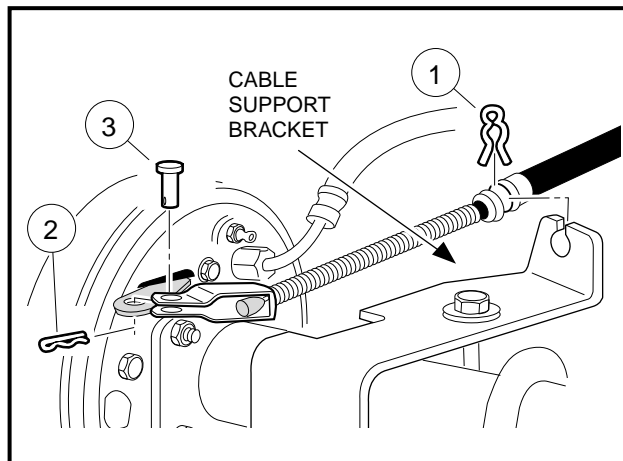

Figure 6-15 Park Brake Cable

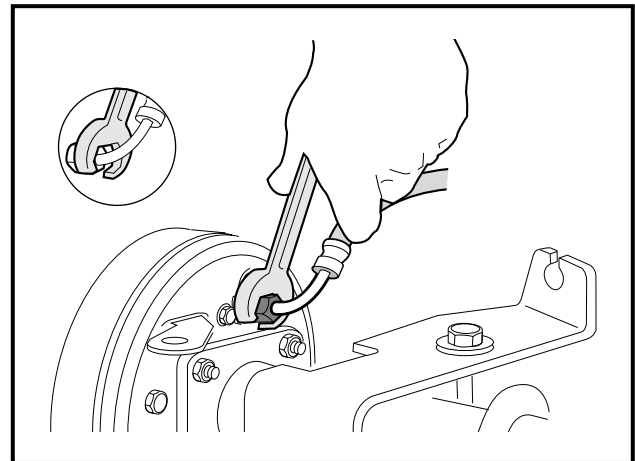

Figure 6-16 Rear Brake Hose

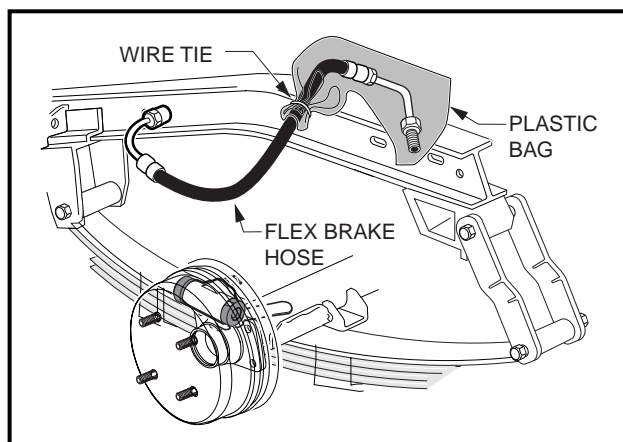

Figure 6-17 Rear Brake Hose With Plastic Bag

6. Remove the four Torx head bolts (16), washers (17) and lock nuts (18) that secure the brake cluster to the axle tube assembly (**Figure 6-18, Page 6-20**).

REAR BRAKE CLUSTER INSTALLATION

1. Use only **new** hardware for this step. Install the brake cluster mounting plate to the axle tube assembly with four Torx head bolts (16), washers (17) and lock nuts (18). Tighten all four bolts to 76 in-lb (8.6 N·m) (**Figure 6-18, Page 6-20**).
2. Connect the brake hose to the brake cluster assembly with a 3/8 inch **flare nut wrench**. Tighten the flare nut fitting to 11 ft-lb (14.9 N·m) (**Figure 6-18, Page 6-20**).
3. Install the park brake cable into the cable support bracket (**Figure 6-15, Page 6-18**).
4. Install the park brake cable clip (1), clevis pin (3) and hair spring cotter pin (2) (**Figure 6-15, Page 6-18**).
5. Install rear axle if required.

NOTE: Clean any residual oil from the exposed end of the axle shaft and from the oil seal area prior to installing the axle shaft.

- 5.1. Clean the axle shaft and splines and then insert the shaft, splined end first, through the seal and into the axle tube. Be careful not to damage the seal. Advance the shaft through the inner bearing and rotate it to align the shaft splines with the splined bore of the differential side gear. Continue advancing the shaft until the bearing seats against the axle tube shoulder.
- 5.2. Install retaining ring in the axle tube (**Figure 6-4, Page 6-9**).
- 5.3. Place a 1/4 to 3/8 inch (6-10 mm) diameter rod against the retaining ring and tap lightly at four to five locations to ensure it is properly seated. **See following WARNING.**

▲ WARNING

- **Be sure retaining ring is properly seated in its groove. If ring is not properly installed, the axle assembly will separate from the transaxle and damage the axle assembly and other components. Loss of vehicle control could result in severe personal injury or death.**
6. Perform the procedure for rear brake drum installation. **See Rear Wheel Brake Drum Installation on page 6-16.**
 7. Bleed the rear brakes as instructed. **See Bleeding the Hydraulic Brake System on page 6-29.**
 8. Perform all of the brake system inspections to ensure that both the hydraulic brake system and the park brake system are adjusted and operating correctly before placing the vehicle into service. **See Brake System Inspection on page 6-2.**

WHEEL CYLINDER REPLACEMENT

Read **WARNING** on page 6-1.

▲ WARNING

- **To perform this procedure, the hydraulic system must be opened. As a result, the brakes must be bled after the correct reinstallation of the brake components. Failure to bleed the brakes could result in decreased braking performance due to air being trapped in the hydraulic system. Use only DOT 5 brake fluid. See Bleeding the Hydraulic Brake System on page 6-29.**

WHEEL CYLINDER REMOVAL

1. Remove brake drum. **See Brake Drum Removal on page 6-7.**
2. Remove brake shoes. **See Brake Shoe Removal on page 6-9.**
3. Remove the brake line or hose from the wheel cylinder (7) (**Figure 6-18, Page 6-20**). **See Hydraulic Line and Hose Replacement on page 6-24.**
4. Remove two bolts and lock washers (9) that secure the wheel cylinder to the brake cluster mounting plate (**Figure 6-1, Page 6-2 or Figure 6-18, Page 6-20**).

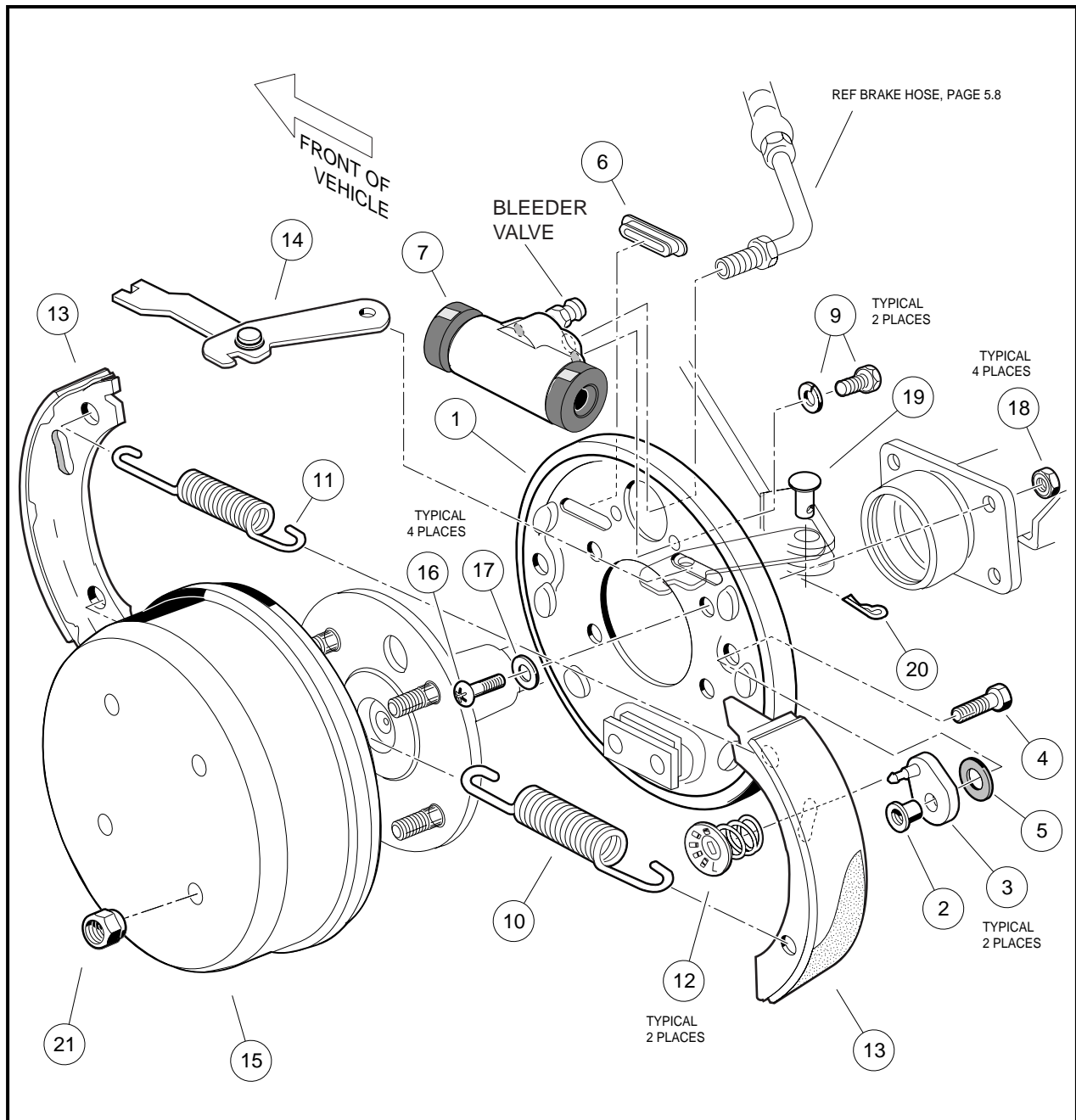

Figure 6-18 Rear Hydraulic Brake Cluster Assembly

WHEEL CYLINDER INSTALLATION

1. Install wheel cylinder with two **new** bolts and lock washers (9) (**Figure 6-18, Page 6-20**). Tighten the two bolts to 120 in-lb (13 N·m).
2. Install the brake line or hose. **See Hydraulic Line and Hose Replacement on page 6-24.**
3. Install brake shoes. **See Brake Shoe Installation on page 6-12.**
4. Bleed brakes as instructed. **See Bleeding the Hydraulic Brake System on page 6-29.**
5. Perform all of the brake system inspections to ensure that both the hydraulic brake system and the park brake system are adjusted and operating correctly before placing the vehicle into service. **See Brake System Inspection on page 6-2.**

BRAKE SHOE ADJUSTER REPLACEMENT

Read **WARNING** on page 6-1.

▲ WARNING

- If at any point in this procedure the hydraulic system is opened, the brakes must be bled after the correct reinstallation of the brake components. Failure to bleed the brakes could result in decreased braking performance due to air being trapped in the hydraulic system. Use only DOT 5 brake fluid. **See Bleeding the Hydraulic Brake System on page 6-29.**

BRAKE SHOE ADJUSTER REMOVAL

1. Remove brake drums. **See Brake Drum Removal on page 6-7.**
2. Remove the rear axle to remove **rear** brake shoes. To remove the **front** brake shoes, proceed to step 3.
 - 2.1. Using 90° internal snap ring pliers (.090 tip) (CCI 1012560), remove internal retaining ring from axle tube (**Figure 6-19, Page 6-21**).

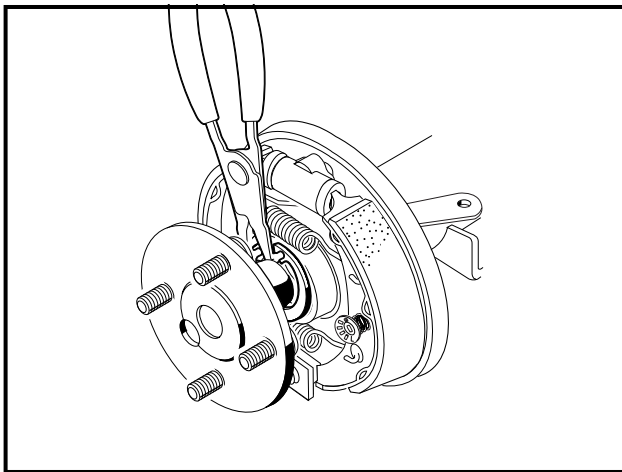

Figure 6-19 Remove Axle Retaining Ring

- 2.2. Carefully pull the axle shaft straight out of the axle tube.
- 2.3. Repeat steps 2.1 and 2.2 for the opposite rear wheel if necessary.

3. Remove brake shoes. **See Brake Shoe Removal on page 6-9.**
4. Remove brake cluster assembly. **See Front Brake Cluster Removal on page 6-17.**
5. Grip adjuster arm (3) with a pair of locking pliers and remove the bolt (4) on the back side of the backing plate with a wrench or socket (**Figure 6-1, Page 6-2 or Figure 6-18, Page 6-20**).
6. Remove and discard all adjuster components (3, 4, and 5) (**Figure 6-1, Page 6-2 or Figure 6-18, Page 6-20**).
7. Clean the backing plate surfaces that contact the adjuster.
8. Repeat steps 1 through 7 for the remaining adjuster. **The adjusters must be replaced as pairs.**

BRAKE SHOE ADJUSTER INSTALLATION

1. Apply a light coat of grease to the belleville washer (5) and install the washer onto the adjuster arm (3) as shown (**Figure 6-1, Page 6-2 or Figure 6-18, Page 6-20**).
2. Carefully apply Loctite® 222 to the bolt (4) (**Figure 6-1, Page 6-2 or Figure 6-18, Page 6-20**).
3. Insert the nose of the tube nut (2) into the backing plate (1). Tighten the bolt to 115 in-lb (13 N·m) (**Figure 6-1, Page 6-2 or Figure 6-18, Page 6-20**).
4. Install brake cluster assembly. **See Brake Cluster Replacement on page 6-17.**
5. Install brake shoes. **See Brake Shoe Installation on page 6-12.**
6. Install rear axle if required.

NOTE: Clean any residual oil from the exposed end of the axle shaft and from the oil seal area prior to installing the axle shaft.

- 6.1. Clean the axle shaft and splines and then insert the shaft, splined end first, through the seal and into the axle tube. Be careful not to damage the seal. Advance the shaft through the inner bearing and rotate it to align the shaft splines with the splined bore of the differential side gear. Continue advancing the shaft until the bearing seats against the axle tube shoulder.
- 6.2. Install retaining ring in the axle tube (**Figure 6-4, Page 6-9**).
- 6.3. Place a 1/4 to 3/8 inch (6-10 mm) diameter rod against the retaining ring and tap lightly at four to five locations to ensure it is properly seated. **See following WARNING.**

⚠ WARNING

- **Be sure retaining ring is properly seated in its groove. If ring is not properly installed, the axle assembly will separate from the transaxle and damage the axle assembly and other components. Loss of vehicle control could result in severe personal injury or death.**
7. Perform all of the brake system inspections to ensure that both the hydraulic brake system and the park brake system are adjusted and operating correctly before placing the vehicle into service. **See Brake System Inspection on page 6-2.**

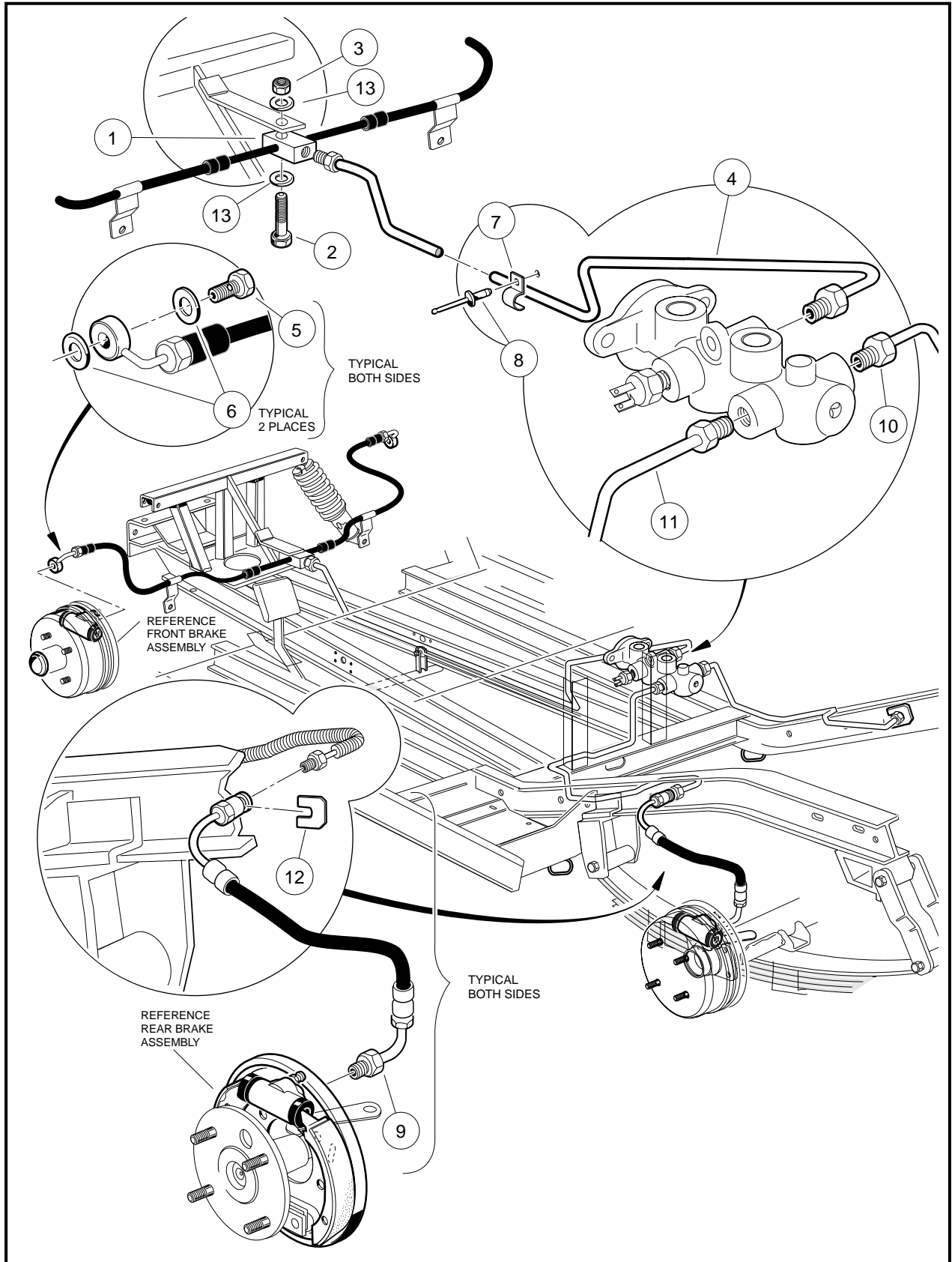

Figure 6-20 Four-Wheel Hydraulic Brake System

HYDRAULIC LINE AND HOSE REPLACEMENT

Read **WARNING** on page 6-1.

⚠ WARNING

- To perform any of these procedures, the hydraulic system must be opened. As a result, the brakes must be bled after the correct reinstallation of the brake components. Failure to bleed the brakes could result in decreased braking performance due to air being trapped in the hydraulic system. Use only DOT 5 brake fluid. See **Bleeding the Hydraulic Brake System** on page 6-29.
- Prior to servicing hydraulic brakes, thoroughly clean the vehicle, paying particular attention to areas immediately surrounding hydraulic connections, to prevent dirt or debris from entering system.

FRONT BRAKE LINE REMOVAL

The following procedure is for the removal of the front brake line (4) (**Figure 6-20, Page 6-23**).

1. Place chocks at the rear wheels, release the park brake and lift the front of the vehicle with a chain hoist or floor jack. Place jack stands under the front frame tube to support the vehicle and lower the floor jack or chain hoist so that the vehicle is resting on the jack stands.
2. Drill the rivet (8) securing the brake line (4) to the vehicle frame (**Figure 6-20, Page 6-23**).
3. Place a pan below the vehicle to collect the brake fluid when the hydraulic system is opened in the following step.
4. Using a **flare nut wrench**, remove the flare nut of the front brake line (4) from the master cylinder (**Figure 6-20, Page 6-23**).
5. Using a **flare nut wrench**, remove brake line (4) from the Y-adaptor block (1) (**Figure 6-20, Page 6-23**).

FRONT BRAKE LINE INSTALLATION

1. Connect the flare nut of the brake line (4) to the master cylinder and tighten finger-tight (**Figure 6-20, Page 6-23**).
2. Connect the flare nut of the brake line (4) to the Y-adaptor block (1) and tighten finger-tight (**Figure 6-20, Page 6-23**).
3. Secure the brake line to the vehicle frame with the P-clamp (7) and a new rivet (8) (**Figure 6-20, Page 6-23**).
4. Fill the reservoir of the master cylinder and bleed the hydraulic system. See **Filling the Hydraulic System** on page 6-31.
5. Perform all of the brake system inspections to ensure that both the hydraulic brake system and the park brake system are in correct adjustment and are operating correctly before placing the vehicle into service. See **Brake System Inspection** on page 6-2.

FRONT BRAKE CLUSTER HOSE REMOVAL

If either of the two front brake hoses or the Y-adaptor (1) are found to be damaged, the entire assembly must be replaced (**Figure 6-20, Page 6-23**).

1. Place chocks at the rear wheels, release the park brake and lift the front of the vehicle with a chain hoist or floor jack. Place jack stands under the front frame tube to support the vehicle and lower the floor jack or chain hoist so that the vehicle is resting on the jack stands.

2. Place a pan below the vehicle to collect the brake fluid when the hydraulic system is opened in the following step.
3. Remove the banjo bolt (15) and copper washers (16) from each of the front brake cluster assemblies (**Figure 6-1, Page 6-2**).
4. Remove the bolt, lock nut, steering weldment stop and front hose bracket from where the bottom of the shock connects to each of the front A-arms.
5. Using a **flare nut wrench**, remove the brake line (4) from the Y-adapter block (1) (**Figure 6-20, Page 6-23**).
6. Remove the bolt (2), two washers (13) and lock nut (3) that secure the Y-adapter (1) to the shock tower (**Figure 6-20, Page 6-23**).
7. Remove the Y-adapter and front hose assembly (1) from the vehicle (**Figure 6-20, Page 6-23**).

FRONT CLUSTER HOSE INSTALLATION

1. Installation is the reverse of removal.
2. Tighten the nut (3) to 76 in-lb (8.6 N·m) (**Figure 6-20, Page 6-23**).
3. Connect the brake hose assembly to each brake cluster assembly with **new** copper washers (16). Tighten the banjo bolts (15) to 13 ft-lb (17.6 N·m) (**Figure 6-1, Page 6-2**).
4. Tighten the lower shock absorber mounting hardware to 20 ft-lb (27 N·m).
5. Connect the flare fitting to the Y-adapter (1) with a **flare nut wrench** and tighten to 11 ft-lb (14.9 N·m) (**Figure 6-20, Page 6-23**).
6. Fill the reservoir of the master cylinder and bleed the hydraulic system. **See Filling the Hydraulic System on page 6-31.**
7. Perform all of the brake system inspections to ensure that both the hydraulic brake system and the park brake system are adjusted and operating correctly before placing the vehicle into service. **See Brake System Inspection on page 6-2.**

REAR BRAKE LINE REMOVAL

1. Place chocks at the rear wheels, release the park brake and lift the rear of the vehicle with a chain hoist or floor jack. Place jack stands under the rear axle tubes to support the vehicle and lower the floor jack or chain hoist so that the vehicle is resting on the jack stands.
2. Place a pan below the vehicle to collect the brake fluid when the hydraulic system is opened in the following step.
3. Using a **flare nut wrench**, remove brake line (10 or 11) from master cylinder (**Figure 6-20, Page 6-23**).
4. Using a **flare nut wrench**, remove the brake line (10 or 11) from the rear brake hose at the I-beam of the vehicle frame (**Figure 6-20, Page 6-23**).

REAR BRAKE LINE INSTALLATION

1. Installation is the reverse of removal.
2. Using a **flare nut wrench**, tighten the flare nut fittings to the master cylinder to 11 ft-lb (14.9 N·m).
3. Using a **flare nut wrench**, install the brake line (10 or 11) to the rear brake hose at the I-beam of the vehicle frame (**Figure 6-20, Page 6-23**). Tighten to 11 ft-lb (14.9 N·m).
4. Fill the reservoir of the master cylinder and bleed the hydraulic system. **See Filling the Hydraulic System on page 6-31.**

5. Perform all of the brake system inspections to ensure that both the hydraulic brake system and the park brake system are adjusted and operating correctly before placing the vehicle into service. **See Brake System Inspection on page 6-2.**

REAR BRAKE CLUSTER HOSE REMOVAL

1. Place chocks at the rear wheels, release the park brake and lift the rear of the vehicle with a chain hoist or floor jack. Place jack stands under the rear axle tubes to support the vehicle and lower the floor jack or chain hoist so that the vehicle is resting on the jack stands.
2. Place a pan below the vehicle to collect the brake fluid when the hydraulic system is opened in the following step.
3. Using a **flare nut wrench**, remove the brake hose from the rear brake cluster assembly (**Figure 6-16, Page 6-18**).
4. Using a **flare nut wrench**, remove the brake line (10 or 11) from the rear brake hose at the I-beam of the vehicle frame (**Figure 6-20, Page 6-23**).
5. Remove the horseshoe clip (12) that secures the rear brake hose (9) to the I-beam of the vehicle frame (**Figure 6-20, Page 6-23**).
6. Remove the brake hose (9) from the vehicle (**Figure 6-20, Page 6-23**).

REAR CLUSTER HOSE INSTALLATION

1. Install brake hose through the D-shaped hole in I-beam.
2. Install horseshoe clip.
3. Using a **flare nut wrench**, tighten the flare nut fitting to the rear brake cluster to 11 ft-lb (14.9 N·m).
4. Using a **flare nut wrench**, install the brake line (10 or 11) to the rear brake hose at the I-beam of the vehicle frame (**Figure 6-20, Page 6-23**). Tighten to 11 ft-lb (14.9 N·m).
5. Fill the reservoir of the master cylinder and bleed the hydraulic system. **See Filling the Hydraulic System on page 6-31.**
6. Perform all of the brake system inspections to ensure that both the hydraulic brake system and the park brake system are adjusted and operating correctly before placing the vehicle into service. **See Brake System Inspection on page 6-2.**

MASTER CYLINDER AND BELL CRANK REPLACEMENT

Read **WARNING** on page 6-1.

BELL CRANK REMOVAL

1. Chock the wheels and release the park brake.
2. Remove the rod retaining bolt (6) and remove the clevis (16) from the bell crank assembly (13) (**Figure 6-21, Page 6-27**).
3. Remove the spring (18) from the bell crank (13) and master cylinder mounting bracket (19) (**Figure 6-21, Page 6-27**).
4. Remove the bolt (20) and lock nut (21) from the bell crank (13) (**Figure 6-21, Page 6-27**).
5. Remove the bolt (9) and nylon lock nut (11) from the master cylinder mounting bracket (19) (**Figure 6-21, Page 6-27**).

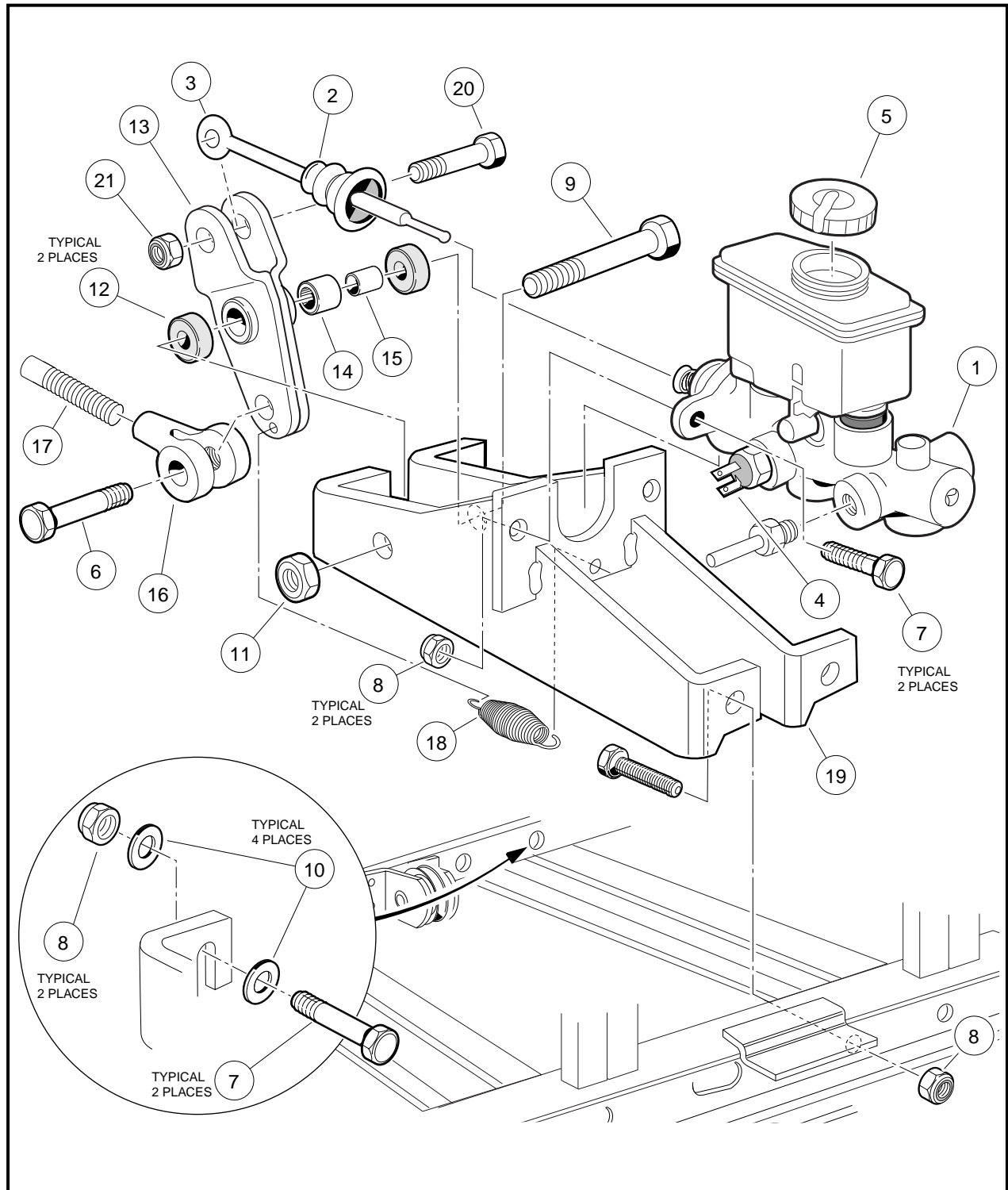

Figure 6-21 Master Cylinder

- Inspect the needle bearing (14) and the inner race (15) for damage or wear and replace if necessary (Figure 6-21, Page 6-27).

NOTE: The needle bearing (14) is press fitted to the bell crank. If replacement is necessary, the bearing must be pressed out and replaced (Figure 6-21, Page 6-27).

BELL CRANK INSTALLATION

1. Install the bolt (9), spacers (12) and inner bearing race (15). Tighten nut (11) to 25 ft-lb (40 N·m) (**Figure 6-21, Page 6-27**).
2. Install push rod (3) into bell crank clevis.
3. Install the bolt (20) and locknut (21) and tighten to 14 ft-lb (19 N·m) (**Figure 6-21, Page 6-27**).
4. Install spring (18) as shown (**Figure 6-21, Page 6-27**).
5. Adjust the brake pedal as instructed in Section 5. **See Brake Pedal Adjustment, Section 5, Page 5-1.**
6. Perform all of the brake system inspections to ensure that both the hydraulic brake system and the park brake system are adjusted and operating correctly before placing the vehicle into service. **See Brake System Inspection on page 6-2.**

MASTER CYLINDER REMOVAL

WARNING

- **To perform this procedure, the hydraulic system must be opened. As a result, the brakes must be bled after the correct reinstallation of the brake components. Failure to bleed the brakes could result in decreased braking performance due to air being trapped in the hydraulic system. Use only DOT 5 brake fluid. See Bleeding the Hydraulic Brake System on page 6-29.**

1. Chock the wheels and release the park brake.
2. Place a pan below the vehicle to collect the brake fluid when the hydraulic system is opened in the following step.
3. Remove the two wires from the master cylinder pressure switch (4) (**Figure 6-21, Page 6-27**).
4. Using a **flare nut wrench**, remove the three brake lines from the master cylinder.
5. Cover the flare nut fittings of the three brake lines with plastic bags and wire ties to keep any dirt or debris from entering the hydraulic system.
6. Remove the two bolts (7) and nylon lock nuts (8) that secure the master cylinder (1) to the master cylinder mounting bracket (19) (**Figure 6-21, Page 6-27**).
7. Remove the master cylinder from the master cylinder mounting bracket.

MASTER CYLINDER INSTALLATION

1. Installation is the reverse of removal.
2. Insert push rod (3) and seat boot (2).
3. Install bolts (7) and nuts (8) and tighten to 14 ft-lb (19 N·m) (**Figure 6-21, Page 6-27**).
4. Tighten the three flare nut fittings at the master cylinder to 11 ft-lb (14.9 N·m).
5. Adjust the brake pedal as instructed in Section 5. **See Brake Pedal Adjustment, Section 5, Page 5-1.**
6. Fill the reservoir of the master cylinder and bleed the entire hydraulic system. **See Filling the Hydraulic System on page 6-31.**
7. Perform all of the brake system inspections to ensure that both the hydraulic brake system and the park brake system are in correct adjustment and are operating correctly before placing the vehicle into service. **See Brake System Inspection on page 6-2.**

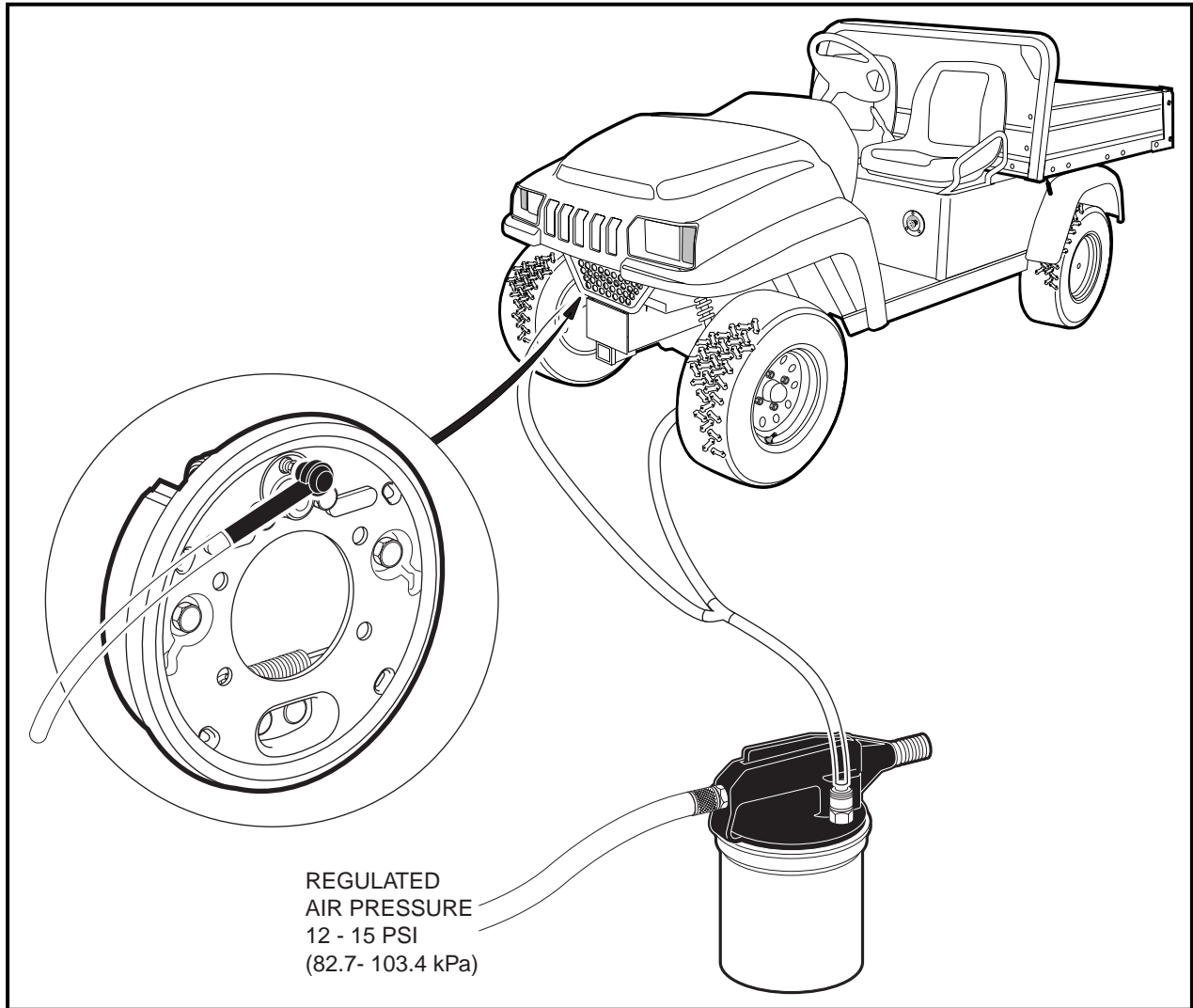

Figure 6-22 Front and Rear Brake Bleeding

BLEEDING THE HYDRAULIC BRAKE SYSTEM

Read **WARNING** on page 6-1.

To properly function, the hydraulic system must be free of air. Air in the hydraulic system will result in a “spongy” brake pedal. Air enters the hydraulic system whenever the system is opened as a result of service or a leak occurs. Air may also enter the system if the brakes are applied when there is very little hydraulic fluid in the brake fluid reservoir.

The master cylinder controls two separate hydraulic sub-systems. The front two wheels are connected to the smaller, front portion of the brake fluid reservoir, and the rear wheels are connected to the rear, larger portion of the brake fluid reservoir. Depending on where the hydraulic system was opened, bleeding of only the front or rear hydraulic brake sub-system may be required. In some situations, bleeding of both the front and rear brake sub-systems will be required. To bleed both the front and rear hydraulic brake sub-systems, use the following procedure to first bleed the two front brakes and repeat the procedure to bleed the two rear brakes.

1. Check the brake pedal and master cylinder push rod for proper adjustment before proceeding. **See Brake Pedal Adjustment, Section 5, Page 5-1.**

2. Turn the key switch to the OFF position, place the Forward/Reverse handle in the NEUTRAL position, chock the front wheels and release the park brake.
3. Remove the cap from the master cylinder reservoir and fill the reservoir with DOT 5 brake fluid.
4. Remove each wheel and gently adjust the clearance between the brake shoes and brake drum by turning each of the two adjusters on the brake cluster as shown (**Figure 6-13, Page 6-16**). Use a hydraulic brake adjuster (CCI 102169401) and torque wrench. **See following CAUTION.**

▲ CAUTION

- Do not apply more than 65 in-lb (7.3 N-m) of torque to any of the adjuster bolts. Over-tightening the adjuster bolts could result in damage to the brake cluster components or the separation of the bolt (4) from the adjuster (3) (**Figure 6-1, Page 6-2 or Figure 6-18, Page 6-20**).
5. Place, but **do not tighten**, the cap onto the master cylinder reservoir.
 6. **Front Brakes Only:** Connect the two hose fittings to a vacuum type brake bleeder to the brake bleeder valves on each of the front brake clusters (**Figure 6-22, Page 6-29**). Proceed to step 8.
 7. **Rear Brakes Only:** Connect the two hose fittings to a vacuum type brake bleeder to the brake bleeder valves on each of the rear brake clusters (**Figure 6-22, Page 6-29**). Proceed to step 8.
 8. Connect an air hose to the vacuum brake bleeder. The air pressure **must** be regulated at 12 to 15 psi (82.7 to 103.4 kPa).
 9. Press the handle on the brake bleeder to start the vacuum.
 10. With the vacuum running, open both of the brake bleeder valves 1/4 turn. **See Figure 6-1, Page 6-2 or Figure 6-18, Page 6-20.**
 11. Monitor the fluid as it flows through the tubes of the vacuum bleeder tool. Continue to run the vacuum until there are almost no air bubbles in the lines. **See following NOTE.**

NOTE: Do not allow the brake fluid in the master cylinder reservoir (**Figure 6-23, Page 6-31**) to drop below the "MIN" level mark at any time during the brake bleeding procedure. Add brake fluid as necessary while performing step 11.

12. With the vacuum still running, tighten the two brake bleeder valves. **See Figure 6-1, Page 6-2 or Figure 6-18, Page 6-20.**
13. Allow the handle on the brake bleeder tool to open, turning the vacuum system off.
14. Fill the master cylinder reservoir to the "MAX" level with DOT 5 brake fluid (**Figure 6-23, Page 6-31**).
15. Repeat procedure for both front and rear brakes.
16. Tighten the cap on the master cylinder reservoir.
17. Properly dispose of the brake fluid in the vacuum type brake bleeder tool.
18. Perform all of the brake system inspections to ensure that both the hydraulic brake system and the park brake system are adjusted and operating correctly before placing the vehicle into service. **See Brake System Inspection on page 6-2.**

PURGING THE HYDRAULIC SYSTEM

In some cases it may be necessary to completely drain the front, rear or entire hydraulic brake system of brake fluid. To completely purge the hydraulic system, perform the following procedure.

1. Perform steps 6 through 10 of the brake bleeding procedure on the two front wheels. **See Bleeding the Hydraulic Brake System on page 6-29.**
2. Allow 1 quart (0.95 liters) of the brake fluid to be pulled into the vacuum type brake bleeder tool.

3. With the vacuum still running, tighten the two brake bleeder valves.
4. Allow the handle on the brake bleeder tool to open, turning the vacuum system off.
5. Repeat steps 1 through 4 for the two rear wheels.

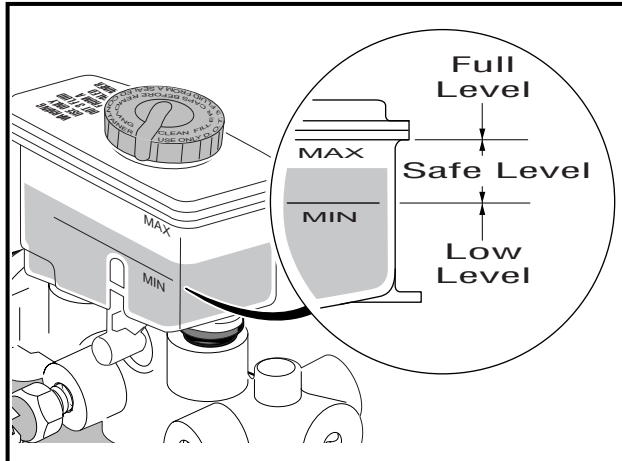

Figure 6-23 Master Cylinder Reservoir

FILLING THE HYDRAULIC SYSTEM

After making any necessary repairs, bleed the brakes, adding DOT-5 brake fluid until the system is full and virtually no air bubbles are present in the brake bleeder vacuum tubes. **See Bleeding the Hydraulic Brake System on page 6-29.**

PARK BRAKE SYSTEM

Read **WARNING** on page 6-1.

PARK BRAKE CABLE REMOVAL

Equalizer Cable Removal

1. Chock the wheels and release the park brake.
2. Remove the two screws (3) that secure the boot (2) to the seat support (**Figure 6-24, Page 6-32**).
3. Slide the boot (2) off of the park brake handle (1) (**Figure 6-24, Page 6-32**).
4. Remove the boot shield (28) from the park brake handle.
5. Remove the equalizer spring (24) from the equalizer cable (9) (**Figure 6-24, Page 6-32**).
6. Remove the equalizer jam nut (11) and conical nut (23).
7. Remove the end of the park brake cable from handle (1) by pushing the equalizer cable in an upward direction and pulling the cable end toward the passenger side of the vehicle.
8. Remove the equalizer cable from the vehicle.

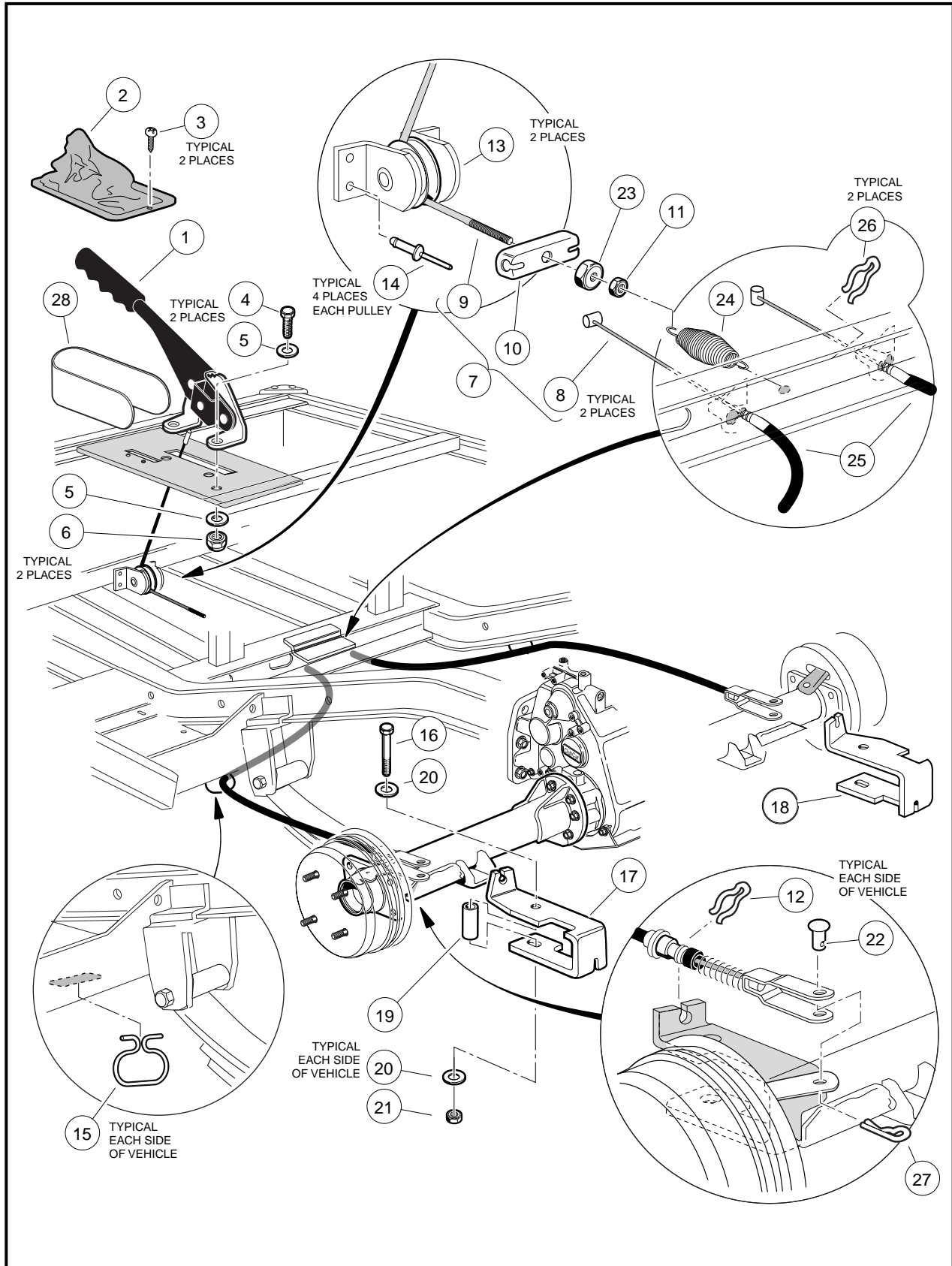

Figure 6-24 Park Brake Assembly

Wheel Brake Cable Removal

1. Chock the wheels and release the park brake.
2. Loosen the equalizer jam nut (11) and the conical nut (23) to provide slack in the wheel brake cables (**Figure 6-24, Page 6-32**).
3. Pull the wheel brake cable to the side and remove the cable end from the keyhole opening in the park brake equalizer (**Figure 6-25, Page 6-33 and Figure 6-26, Page 6-33**).
4. Remove the cable clip (26) from the wheel brake cable (25) (**Figure 6-24, Page 6-32**).
5. Remove the park brake cable clip (12), hair spring cotter pin (27) and clevis pin (22).
6. Remove the cable from the cable support bracket (17 or 18).
7. Slide the cable through the hanger (15) and remove the cable from the vehicle.
8. If necessary, remove the other wheel brake cable in the same manner.

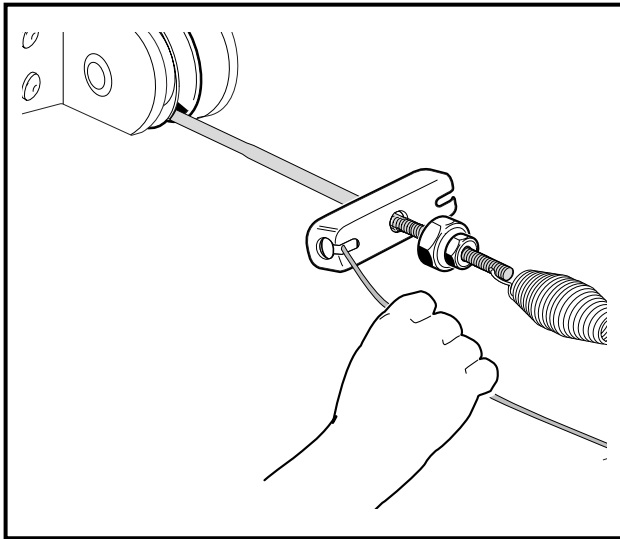

Figure 6-25 Wheel Brake Cable Removal

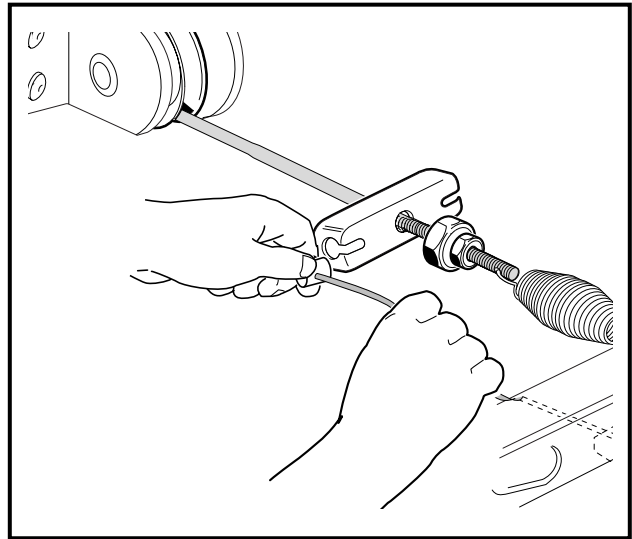

Figure 6-26 Wheel Brake Cable Removal

PARK BRAKE CABLE INSTALLATION

Equalizer Cable Installation

1. Installation is the reverse of removal.
2. Adjust the park brake. **See Park Brake Adjustment on page 6-34.**

Wheel Brake Cable Installation

1. Installation is the reverse of removal.
2. Adjust the park brake. **See Park Brake Adjustment on page 6-34.**

PARK BRAKE HANDLE REMOVAL

1. Remove the park brake equalizer cable. **See Equalizer Cable Removal on page 6-31.**
2. Remove the two bolts (4), four washers (5) and two lock nuts (6) from the park brake handle (**Figure 6-24, Page 6-32**).
3. Remove the park brake handle (1) from the seat support.

PARK BRAKE HANDLE INSTALLATION

1. Install the two bolts (4), four washers (5) and two lock nuts (6) to secure the park brake handle to the seat support (**Figure 6-24, Page 6-32**). Tighten the nuts (6) to 23 ft-lb (31.4 N·m).
2. Install the park brake cable. **See Equalizer Cable Removal on page 6-31.**
3. Adjust the park brake. **See Park Brake Adjustment on page 6-34.**
4. Install the boot shield (28), and boot (2). Tighten the two screws (3), to secure the park brake boot (**Figure 6-24, Page 6-32**).
5. Perform all of the brake system inspections to ensure that both the hydraulic brake system and the park brake system are adjusted and operating correctly before placing the vehicle into service. **See Brake System Inspection on page 6-2.**

PARK BRAKE ADJUSTMENT

1. Ensure that the brake pedal is adjusted correctly. **See Brake Pedal Adjustment, Section 5, Page 5-1.**
2. Chock the wheels, release the park brake and place the F&R handle in the NEUTRAL position.
3. Loosen the equalizer cable.
 - 3.1. Loosen the equalizer jam nut (11) and the conical nut (23) to provide slack in the wheel brake cables (**Figure 6-24, Page 6-32**).
4. Gently adjust the clearance between the brake shoes and brake drum by turning each of the two adjusters on both rear brake clusters as shown (**Figure 6-13, Page 6-16**). Use a hydraulic brake adjuster (CCI 102169401) and torque wrench. **See following CAUTION.**

⚠ CAUTION

- *Do not apply more than 65 in-lb (7.3 N·m) of torque to any of the adjuster bolts. Over-tightening of the adjuster bolts could result in damage to the brake cluster components or the separation of the bolt (4) from the adjuster (3) (**Figure 6-1, Page 6-2 or Figure 6-18, Page 6-20**).*
5. With the park brake released (down), tighten the conical nut (23) until significant resistance is observed in the equalizer cable in order to fully lock the brakes (**Figure 6-24, Page 6-32**).
 6. With the vehicle on flat ground and the Forward/Reverse handle in the NEUTRAL position, push the vehicle by hand. If the wheels move when the vehicle is pushed, continue tightening the conical nut until the vehicle can no longer be pushed.
 7. Loosen the conical nut two full revolutions.
 8. Using the double-wrench method, tighten the equalizer jam nut (11) against the conical nut (23) to 55 in-lb (6.3 N·m) (**Figure 6-24, Page 6-32**).
 9. The park brake should now be adjusted so that the vehicle will not roll when pushed with the park brake latched in the fourth notch (four clicks from the bottom of its travel).
 10. Perform all of the brake system inspections to ensure that both the hydraulic brake system and the park brake system are adjusted and operating correctly before placing the vehicle into service. **See Brake System Inspection on page 6-2.**

SECTION 7 – STEERING AND FRONT SUSPENSION

▲ WARNING

- Only trained technicians should repair or service this vehicle. Anyone doing even simple repairs or service should have knowledge and experience in electrical and mechanical repair.
- Follow all procedures exactly as stated in this manual, and heed all DANGER, WARNING, and CAUTION statements in this manual as well as those affixed to the vehicle.
- Wear safety glasses or approved eye protection while servicing vehicle. Wear a full face shield and rubber gloves when working with batteries.
- Turn key switch OFF, place Forward/Reverse handle in the NEUTRAL position and remove key prior to servicing.
- Moving parts! Do not wear loose clothing. Remove jewelry such as rings, watches, chains, etc. before servicing vehicle.
- Use insulated tools when working near batteries or electrical connections. Use extreme caution to avoid shorting of components or wiring.
- To avoid unintentionally starting the vehicle:
 - Disconnect battery cables, negative cable (–) first.
 - Disconnect the spark plug wire from the spark plug.
- Frame ground – Do not allow tools or other metal objects to contact frame when disconnecting battery cables or electrical wiring. Never allow a positive wire to touch the vehicle frame, engine or any other metal component.
- Lift only one end of the vehicle at a time. Before lifting, set the park brake when lifting the front of the vehicle, unload the cargo bed and chock the wheels that remain on the floor. Use a suitable lifting device (chain hoist or hydraulic floor jack) with 1000 lb. (454 kg) minimum lifting capacity. Do not use lifting device to hold vehicle in raised position. Use approved jack stands of proper weight capacity to support the vehicle.

GENERAL INFORMATION

Steering is controlled through a rack and pinion steering assembly that is connected by a steering column to a steering wheel. No manual adjustment to the rack and pinion gear assembly is required. A spring loaded self-adjusting mechanism is incorporated into the assembly.

STEERING WHEEL

Read WARNING on page 7-1.

STEERING WHEEL REMOVAL

1. Disconnect battery and spark plug as instructed. See WARNING on page 7-1.
2. Remove the two mounting screws (24) and plate (19) (Figure 7-1, Page 7-2).

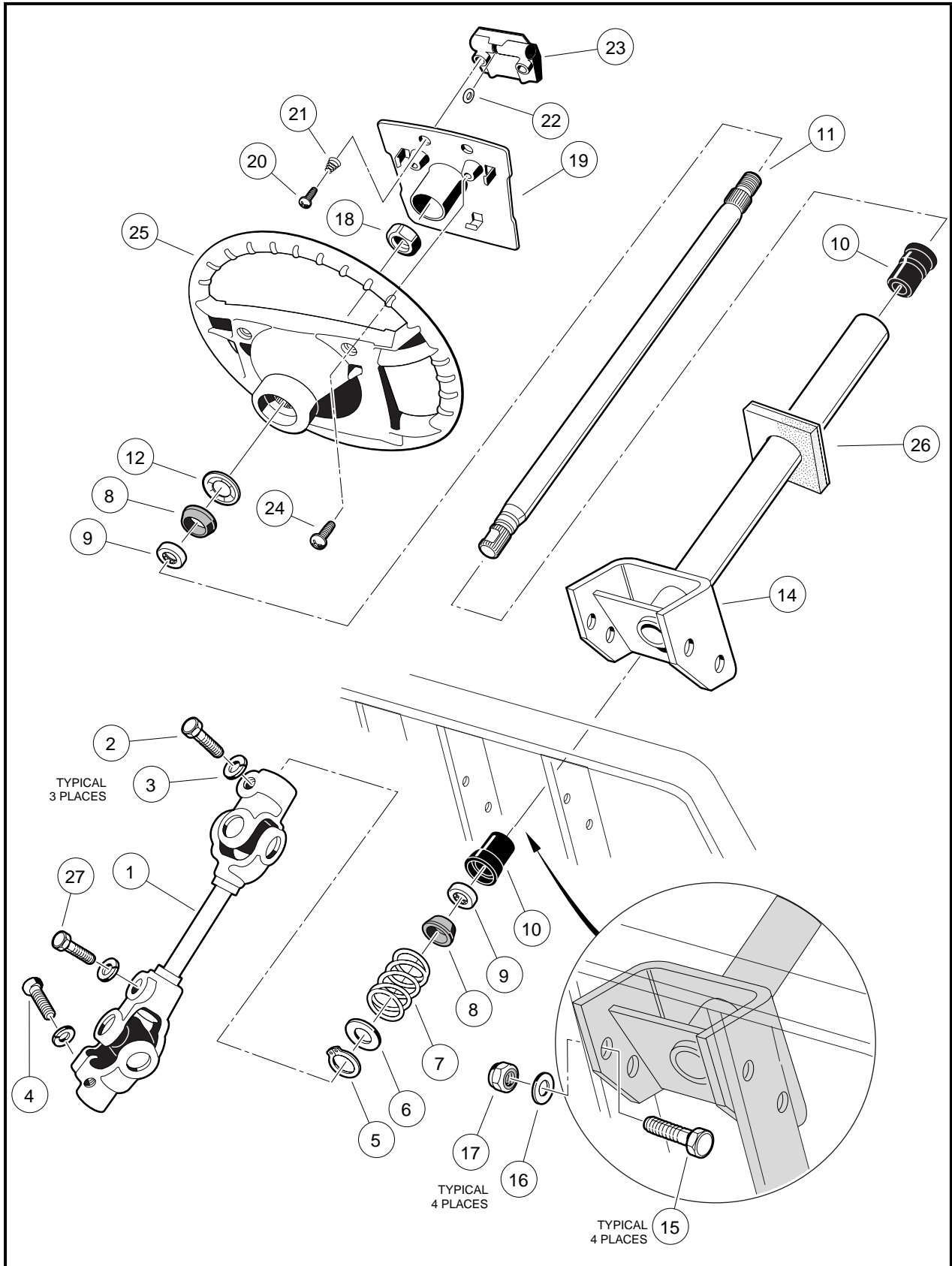

Figure 7-1 Steering Column

3. Match mark the steering wheel (25) and steering column shaft (11) so when the steering wheel is removed it can be placed back in exactly the same position on steering column shaft (**Figure 7-1, Page 7-2**).
4. Loosen the steering wheel nut (18) and back it off approximately 1/4 inch (6 mm). Do not remove the nut (**Figure 7-1, Page 7-2**).
5. Use the steering wheel puller (CCI 102061201) to remove steering wheel.
 - 5.1. Place the puller anvil (4) through the top opening of the steering wheel (**Figure 7-2, Page 7-3**).
 - 5.2. Insert the anvil feet through the two slots in the base plate (marked "B") (5) as shown (**Figure 7-2, Page 7-3**).
 - 5.3. Rotate the anvil screw (6) clockwise until the base plate contacts the bottom of the steering wheel where it attaches to the steering column (**Figure 7-3, Page 7-3**).
 - 5.4. Using a 1/2 inch drive air impact wrench, tighten the anvil screw (6) until the steering wheel breaks free from the steering shaft.
 - 5.5. Remove the steering wheel puller.
 - 5.6. Remove the steering wheel nut (18) and the steering wheel from the steering column (14) (**Figure 7-1, Page 7-2**).

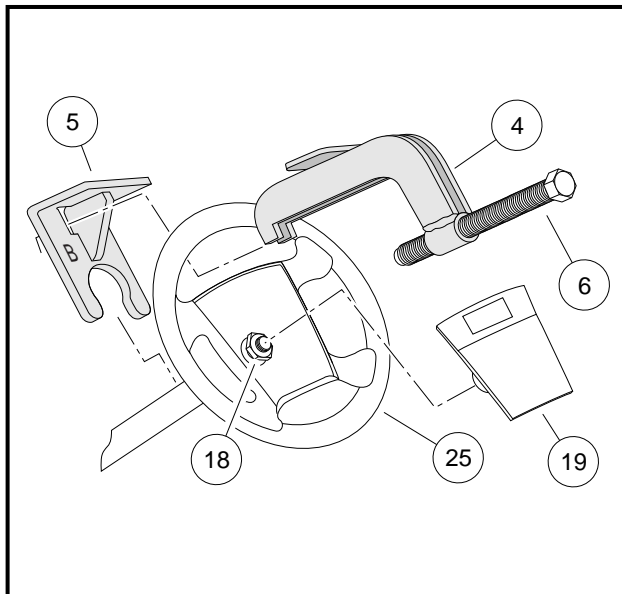

Figure 7-2 Steering Wheel Puller

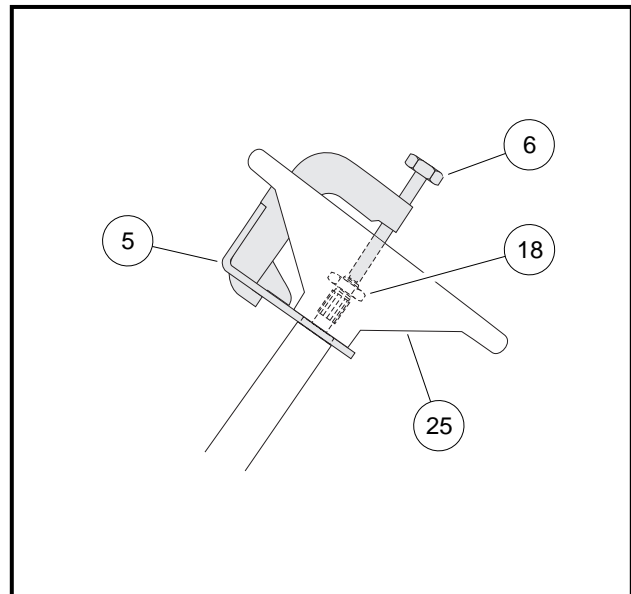

Figure 7-3 Steering Wheel Puller

STEERING WHEEL INSTALLATION

NOTE: To minimize corrosion and to make future removal of the steering wheel easier, apply a small amount of oil or anti-seize compound to steering shaft splines and taper before installing the steering wheel.

1. Install the steering wheel (25) on the splines of the steering shaft (11). Be sure to align the match marks placed on the wheel and steering column shaft in step 3 above (**Figure 7-1, Page 7-2**).
2. Install the steering wheel nut (18) and tighten to 13 ft-lb (17.6 N·m) (**Figure 7-1, Page 7-2**).
3. Install the steering wheel plate (19) and plate mounting screws (24) (**Figure 7-1, Page 7-2**). Tighten screws to 16 in-lb (1.8 N·m).

STEERING COLUMN

Read **WARNING** on page 7-1.

STEERING COLUMN REMOVAL

1. Disconnect the battery and spark plug as instructed in the **WARNING** on page 7-1.
2. Remove the steering wheel. **See Steering Wheel Removal on page 7-1.**
3. Remove dashboard. **See Dashboard Removal, Section 4, Page 4-3.**
4. Disconnect the wires from the electrical components mounted on the dash panel.
5. Remove the front body. **See Front Body Removal, Section 4, Page 4-3.**
6. Remove the upper bolt (2) and lock washer (3) from the universal joint (1) (**Figure 7-4, Page 7-4**).
7. Remove the nuts (17), bolts (15), and washers (16) from the steering column mount (14) (**Figure 7-1, Page 7-2**).
8. Disconnect the U-joint (1) from the steering column shaft and remove the steering column from the vehicle (**Figure 7-4, Page 7-4**).

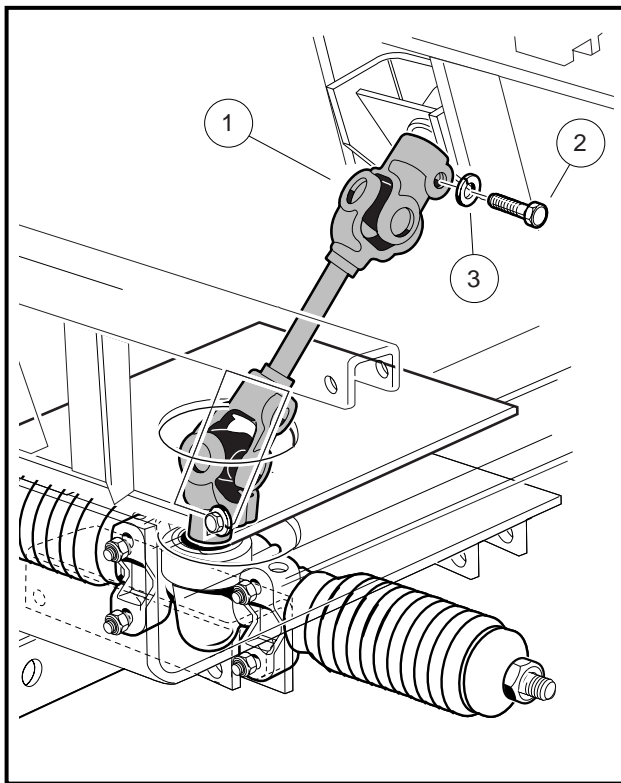

Figure 7-4 Steering U-Bolt

STEERING COLUMN DISASSEMBLY

1. While supporting steering column (14) on a workbench, remove snap ring (5) from shaft (**Figure 7-1, Page 7-2**).

NOTE: Do not allow the steering shaft to slide out of the steering tube when removing the snap ring.

2. Remove the washer (6), spring (7), and wedge (8) (**Figure 7-1, Page 7-2**).

- Turn the steering column over and slide the shaft out of the tube to expose the retaining ring (12). Use pliers to twist the retaining ring (12) until it breaks off, then remove the wedge (8) (**Figure 7-1, Page 7-2**).
- Remove the shaft (11) from the bottom of the tube (14) (**Figure 7-1, Page 7-2**).
- Use steering shaft (11) to push bearing seat (10) out from the opposite end of the steering tube (14) (**Figure 7-1, Page 7-2**).
- Insert a flat blade screwdriver between the bottom of the outer race of the bearing (9) and the bottom lip of the bearing seat (10) and remove the bearing (9) (**Figure 7-1, Page 7-2**).

NOTE: Use new retaining rings and bearings for reassembly.

STEERING COLUMN ASSEMBLY

- Insert bearing seat (10) into both ends of steering tube (14). Place a block of wood on bearing seat and tap lightly on block until bearing seat (10) is fully seated in steering tube (14) (**Figure 7-5, Page 7-5** and **Figure 7-6, Page 7-5**).

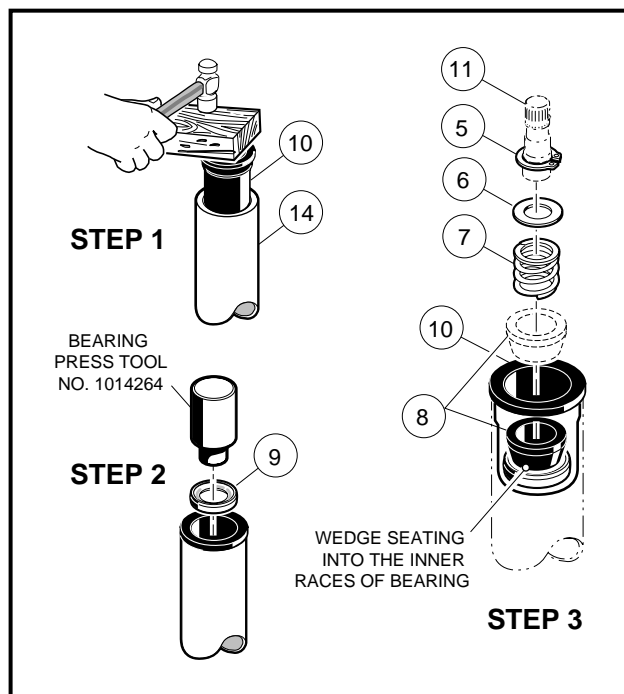

Figure 7-5 Steering Shaft – Bottom End

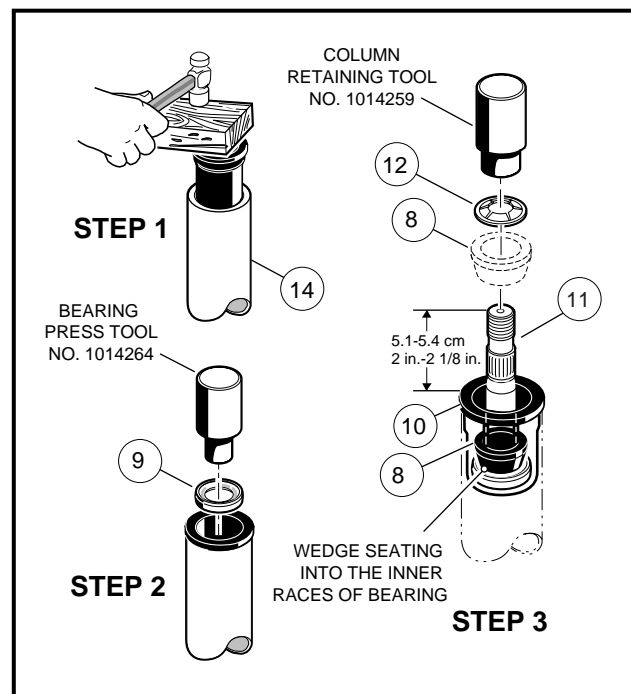

Figure 7-6 Steering Shaft – Top End

- Press the bearing (9) all the way into the bearing seat (10) using a steering column bearing press tool (CCI 1014264) or a metal tube approximately six inches (15.2 cm) long with a maximum outer diameter of 1-3/16 inches (3.3 cm) and a minimum inside diameter of 7/8 inch (2.2 cm). Be sure the bearing is installed in the bearing seat as shown (**Figure 7-5, Page 7-5**) so the wedge (8) will ride against the inner race of the bearing.
- Install the wedge (8), spring (7), washer (6) and snap ring (5) onto the bottom end of the steering shaft (11) (**Figure 7-5, Page 7-5**).

Steering Column Assembly, Continued:

4. Insert the shaft (11) from the bottom of the steering tube (14) (**Figure 7-1, Page 7-2**).
5. Turn the assembly over and place the shaft (11) on a bench. Install the wedge (8) and retaining ring (12) onto the top of the shaft. Be sure the prongs on the retaining ring face up and away from the wedge. Use a steering column retaining ring tool (CCI 1014259) to seat the retaining ring to the proper depth. Support end of tube while pressing. If you do not have the recommended tool, use the same tube as was used in Step 2 to press the retaining ring onto the top of the shaft. The retaining ring should be pressed onto the shaft until 2 to 2-1/8 inches (5.1-5.4 cm) of the shaft extends from the top of the bearing seat in the steering tube (**Figure 7-6, Page 7-5**).

STEERING COLUMN INSTALLATION

1. Install boot (26) (if previously removed) (**Figure 7-1, Page 7-2**).
2. For ease of assembly and to prevent corrosion, apply a light coat of anti-seize or lubricating compound to both splined ends of the steering shaft.
3. Position the steering column assembly in the vehicle while inserting the steering column shaft into the upper universal joint (1). The flat portion of the steering shaft spline (11) must be aligned with the bolt hole in the universal joint (1) before sliding the spline into the universal joint (**Figure 7-1, Page 7-2**).
4. Install the bolt (2) and lock washer (3) on the upper universal joint and finger tighten (**Figure 7-4, Page 7-4**).
5. While holding the steering column in place, attach it to the frame using bolts (15), washers (16) and lock nuts (17) (**Figure 7-1, Page 7-2**). Tighten the four bolts, in a crisscross pattern to 23 ft-lb (31.2 N·m).
6. Tighten the bolt (2) on the upper universal joint to 15 ft-lb (20 N·m) (**Figure 7-1, Page 7-2**).
7. Check all universal joint bolts for proper torque of 15 ft-lb (20 N·m).
8. Install the front body. **See Front Body Installation, Section 4, Page 4-5.**
9. Install dashboard. **See Dashboard Installation, Section 4, Page 4-3.**
10. Install dash panel. **See Dash Panel Installation, Section 4, Page 4-3.**
11. Install the steering wheel. **See Steering Wheel Installation on page 7-3.**
12. Inspect the brake hoses at the front wheels. When turning the steering wheel all the way from left to right and back again, the hoses should not come in contact with any component, especially the wheels or tires.

RACK AND PINION

Read **WARNING** on page 7-1.

RACK AND PINION REMOVAL

1. Place chocks at the rear wheels, loosen the front wheel lug nuts and lift the front of the vehicle with a chain hoist or floor jack. Place jack stands under the front frame tube to support the vehicle and lower the floor jack or chain hoist so that the vehicle is resting on the jack stands.
2. Remove the lug nuts from the front wheels.
3. Remove the cotter pins (18) and ball joint retaining nuts (24) (**Figure 7-20, Page 7-11**).

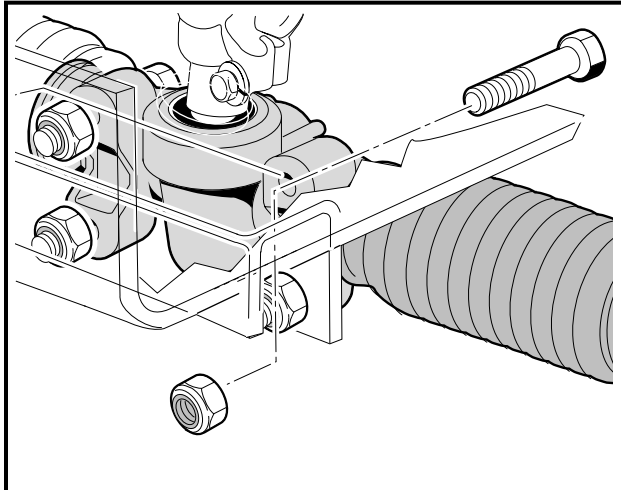

Figure 7-7 Rack and Pinion Bolts

4. Remove the ball joints (23) from the spindle assemblies (**Figure 7-20, Page 7-11**).
5. Remove the four bolts (20), washers (21) and nuts (22) from the steering rack assembly mounting bracket (**Figure 7-7, Page 7-7 and Figure 7-20, Page 7-11**).
6. Remove the bolt (27) and lock washer (**Figure 7-1, Page 7-2**) from the universal joint, then remove the rack assembly and universal joint from the vehicle (**Figure 7-8, Page 7-7**).

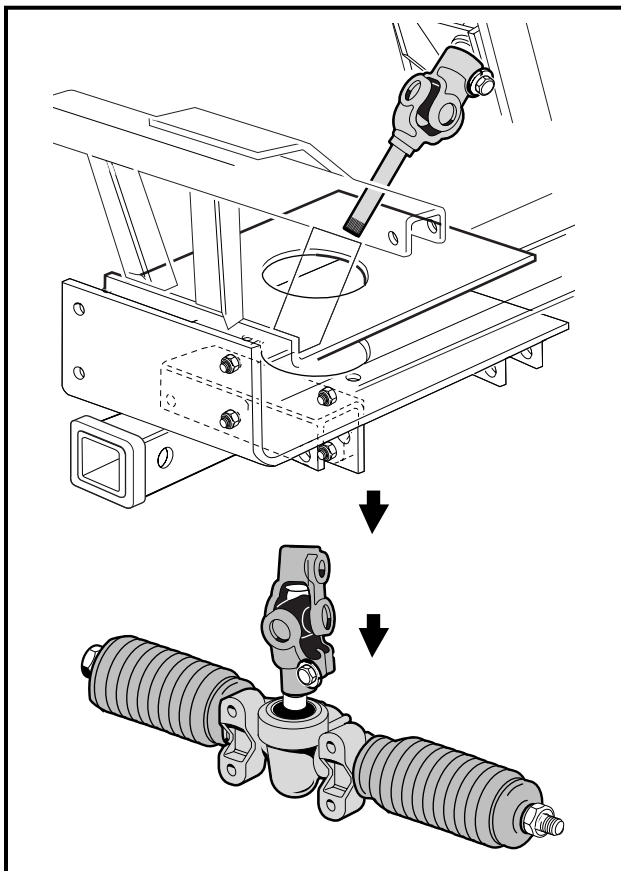

Figure 7-8 Remove Rack and Pinion

RACK AND PINION DISASSEMBLY

1. Using the double-wrench method, remove the two ball joints and inspect them for excessive wear (**Figure 7-9, Page 7-8**).
2. With one wrench on the flat surface of the drag link, and another wrench on the ball joint jam nut, remove the drag link (28) (**Figure 7-10, Page 7-8**). Repeat this step for the other drag link.
3. Remove both bellows clamps (metal clamps or plastic wire ties) (**Figure 7-11, Page 7-8**).

NOTE: If the dust seal bellows are secured with a metal clamp, use a pair of pliers to remove the clamp. Do not attempt to reuse the clamp when the rack and pinion is reassembled. Use a plastic wire tie to secure the dust seal bellows.

4. Remove the two hex nuts (12) and slide off both of the dust seal bellows (10) (**Figure 7-20, Page 7-11**).

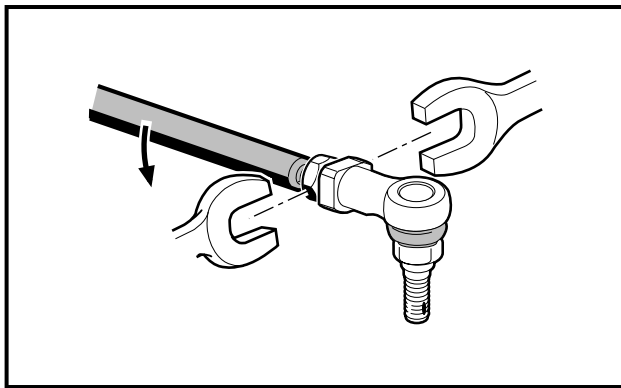

Figure 7-9 Ball Joint

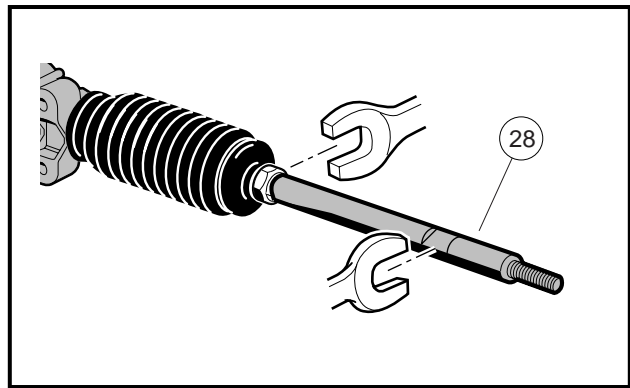

Figure 7-10 Drag Link

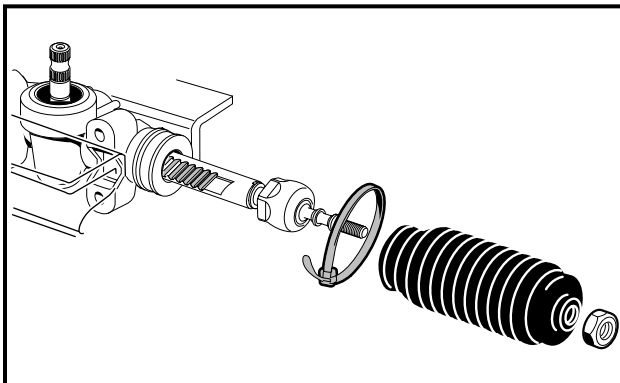

Figure 7-11 Dust Bellows Clamp

5. Remove the rack screw nut (8), rack guide screw (7), rack guide pressure spring (6) and the rack guide (5) (**Figure 7-20, Page 7-11**).
6. Remove the universal joint assembly from the pinion (3) by fully removing the bolt and then sliding off the universal joint (**Figure 7-20, Page 7-11**).
7. Remove the dust seal (**Figure 7-14, Page 7-9**).
8. Using snap ring pliers, remove the snap ring (**Figure 7-15, Page 7-9**).

9. Install the universal joint onto the pinion and place a fork or a large open end wrench under the universal joint (**Figure 7-16, Page 7-10**). Gently pry the pinion from the housing (**Figure 7-17, Page 7-10**).

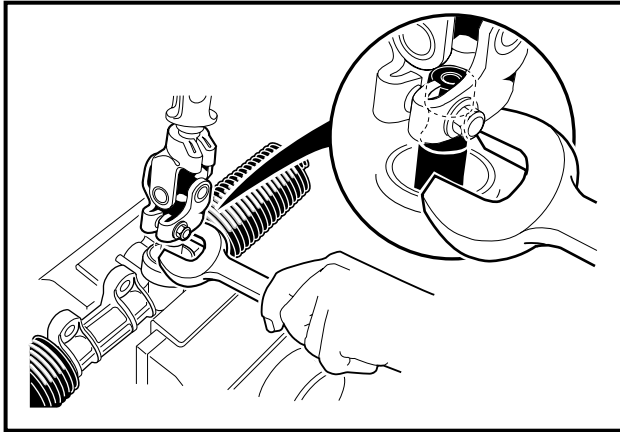

Figure 7-12 Remove Pinion from Housing

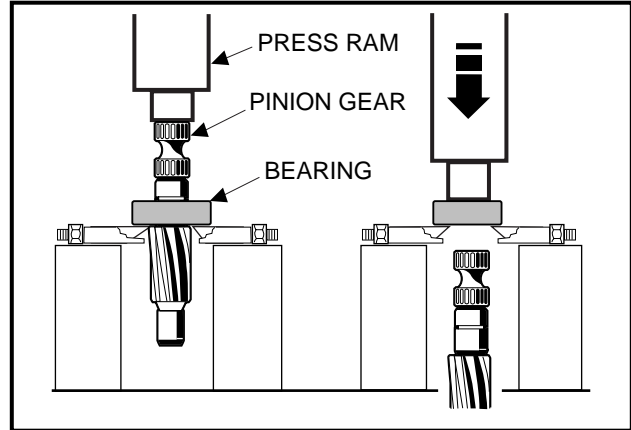

Figure 7-13 Remove Bearing from Pinion

10. Remove the U-joint from the pinion (3) (**Figure 7-20, Page 7-11**).
11. If the ball bearing (15) has been damaged, remove the c-type stop ring (16) (**Figure 7-15, Page 7-9**) and press the bearing off (**Figure 7-13, Page 7-9**).
12. Inspect the bushing (17) and needle bearing (14) for excessive wear. If wear is excessive, replace the steering box assembly (CCI 102010101) (**Figure 7-20, Page 7-11**).
13. Inspect the ball joints (9) for wear (**Figure 7-20, Page 7-11**). If one or both of the ball joints (9) are excessively worn, remove the worn ball joint from the rack.
- 13.1. Secure the rack in a vise (**Figure 7-18, Page 7-10**). Use wood blocks between the rack and the jaws of the vise to protect the rack from damage.
- 13.2. Tap the flange out of the notch in the rack (**Figure 7-19, Page 7-10**).
- 13.3. Using a wrench, remove the ball joint (9) from the rack (2) (**Figure 7-20, Page 7-11**).
14. Remove the rack (2) from housing (1) (**Figure 7-20, Page 7-11**).

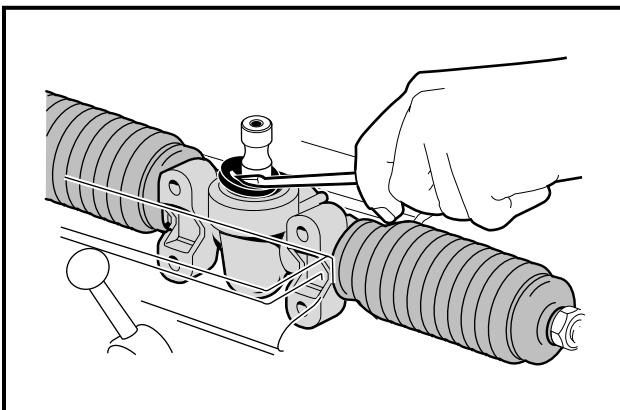

Figure 7-14 Remove Dust Seal

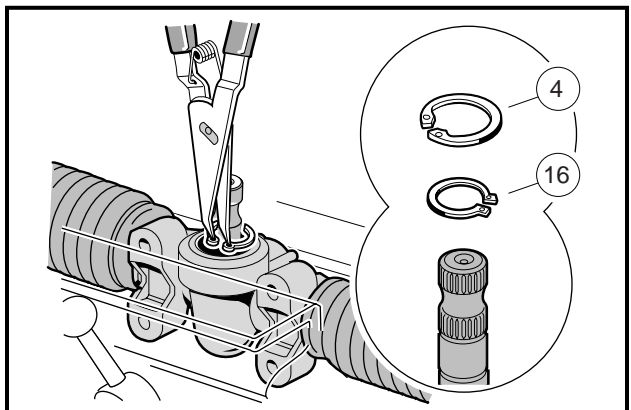

Figure 7-15 Pinion Snap Rings

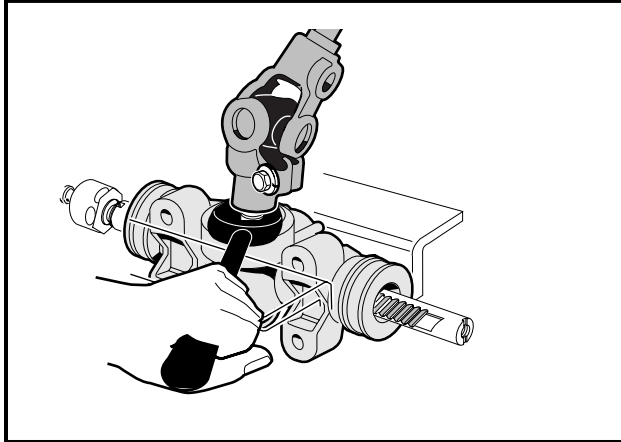

Figure 7-16 Remove Pinion

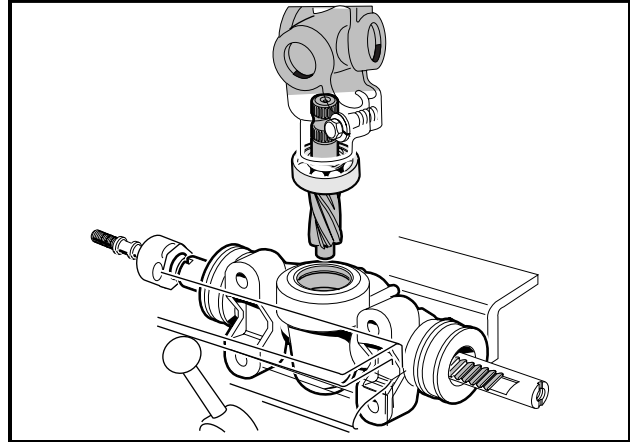

Figure 7-17 Remove Pinion Gear Assembly

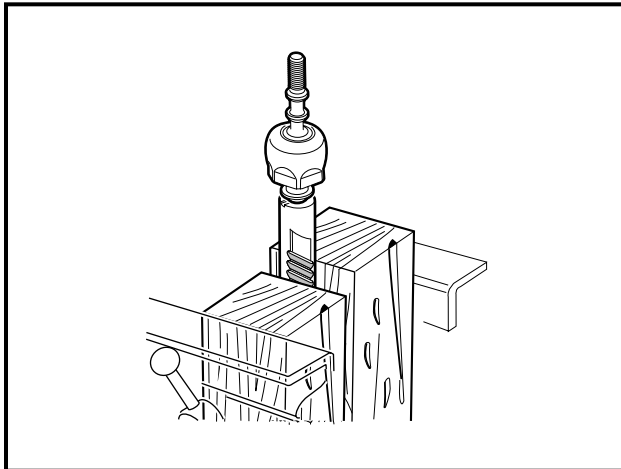

Figure 7-18 Remove Rack

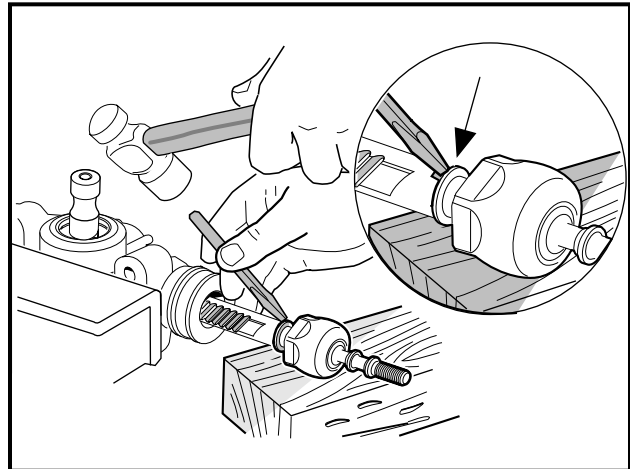

Figure 7-19 Remove Ball Joint

RACK AND PINION ASSEMBLY

1. Apply a liberal amount of EP grease to the teeth of the rack (2), then slide the rack through the bushing (17) and housing (1) (**Figure 7-20, Page 7-11**).

⚠ CAUTION

- In step 2, do not press against the outer race of the bearing.
2. If the pinion bearing (15) was removed, grease a new bearing before installation. Press new bearing onto pinion shaft, exerting all pressure on the inner race. Then install the c-type stop ring (16) (**Figure 7-20, Page 7-11**).
 3. Install pinion (3) and bearing (15) assembly into the housing (1) (**Figure 7-20, Page 7-11**). Make sure the rack gear teeth will mesh with the gear teeth on the pinion. The rack may need to be rotated slightly while lightly tapping on the pinion-bearing assembly with a rubber mallet. **See following CAUTION.**

⚠ CAUTION

- Do not force the pinion-bearing assembly into the housing. The Gear teeth or the small bearing could be damaged.

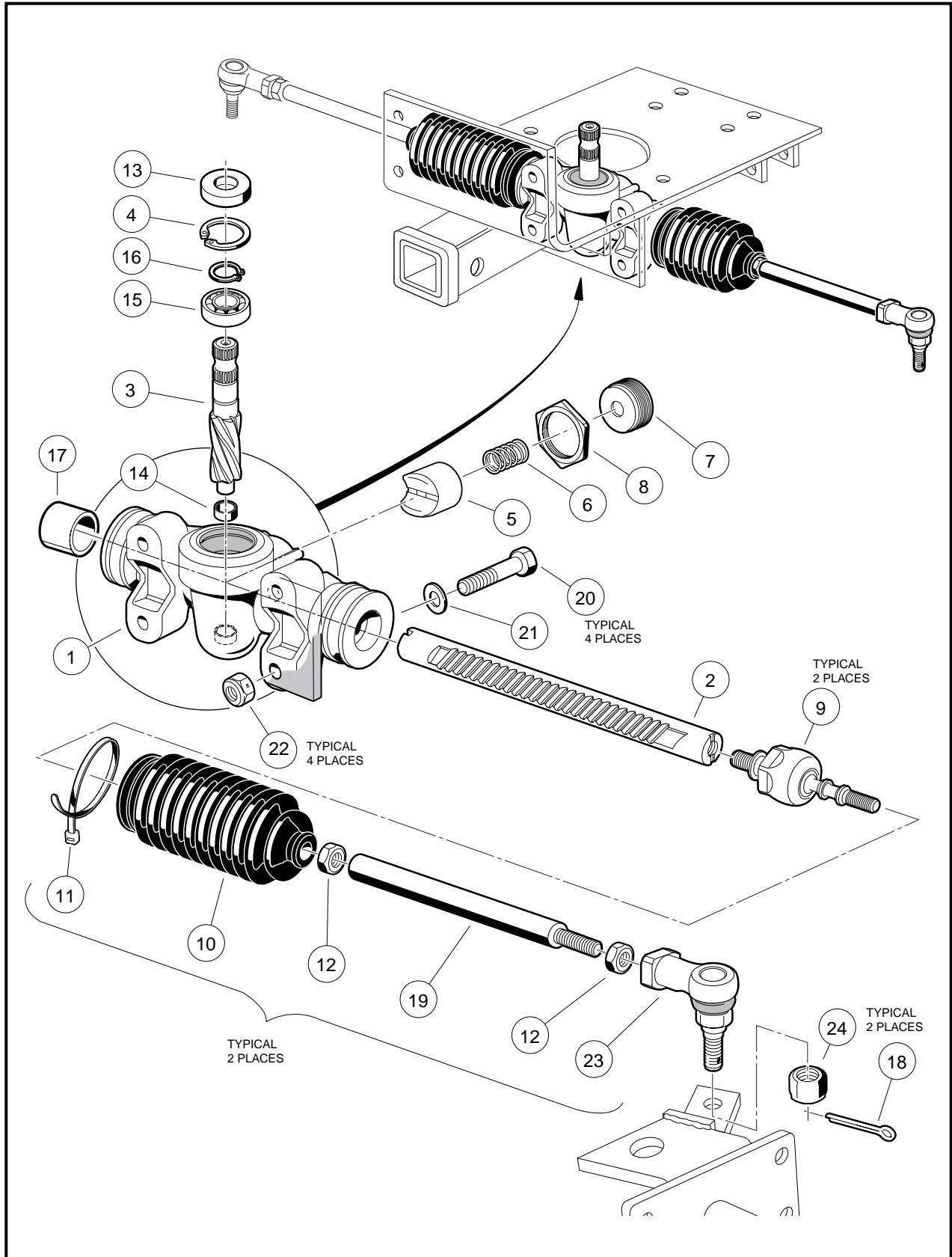

Figure 7-20 Steering Gear

4. Install the snap ring (4) (**Figure 7-20, Page 7-11**).
5. Using a socket to apply pressure evenly, press in a **new** dust seal (**Figure 7-21, Page 7-12**).
6. Apply a small amount of grease to the rack guide (5) where it comes into contact with the rack (2) (**Figure 7-20, Page 7-11**).
7. Place a few drops of Loctite® 222 to the threads of the screw (7) (**Figure 7-20, Page 7-11**).
8. Install the ball joints onto the rack by securing the rack in a vise using wood blocks between the rack and the jaws of the vise to protect the rack from damage. Tighten the ball joints to 60 ft-lb (81 N·m).
9. Install the rack guide (5), pressure spring (6) and screw (7) (**Figure 7-20, Page 7-11**). The screw should be threaded in until it bottoms out and then backed out 1/4 turn (**Figure 7-22, Page 7-12**).

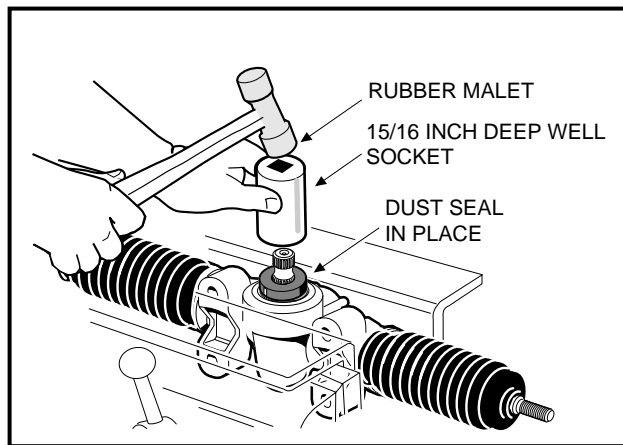

Figure 7-21 Press In Dust Seal

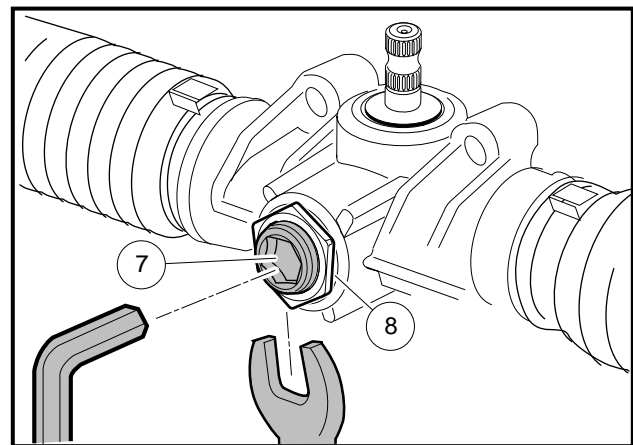

Figure 7-22 Rack and Pinion Adjustment

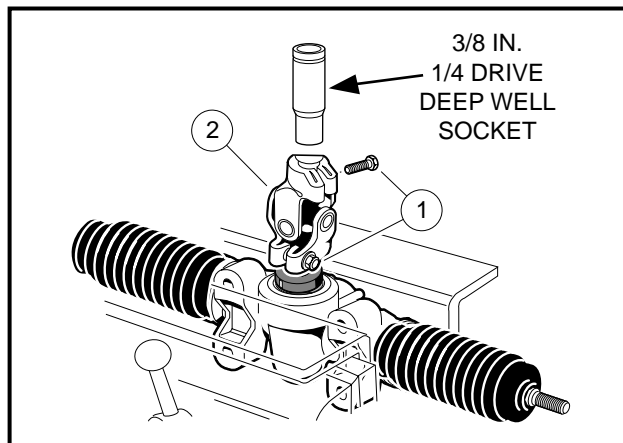

Figure 7-23 Rack and Pinion Resistance

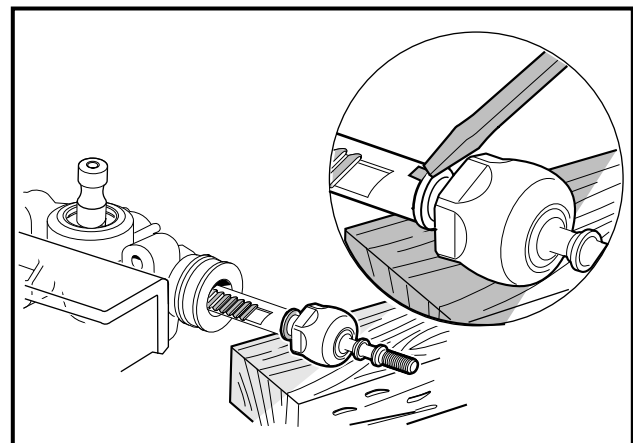

Figure 7-24 Install Ball Joint

10. Insert a 3/8 inch deep well socket into the steering column end of the universal joint (2) and tighten the bolts (1) to 15 ft-lb (20.3 N·m) (**Figure 7-23, Page 7-12**).
11. Use a torque wrench connected to the 3/8 inch deep well socket to measure the resistance of the rack and pinion. Rotational resistance should measure 7 to 15 in-lb (.8 to 1.7 N·m).
12. If measured resistance is not 7 to 15 in-lb (.8 to 1.7 N·m), adjust the screw (7) until correct setting is achieved. Tighten the nut (8) to 28 ft-lb (38 N·m) (**Figure 7-22, Page 7-12**). **See following NOTE.**

NOTE: When tightening the nut (8) make sure the screw (7) does not change adjustment (**Figure 7-22, Page 7-12**).

13. Install the ball joints (9) to each end of the rack (2). Tighten to 20 ft-lb (27 N·m) (**Figure 7-20, Page 7-11**).
14. Tap a flange into the notch on the rack (**Figure 7-24, Page 7-12**).
15. Install the two dust seal bellows (10) (**Figure 7-20, Page 7-11**).
16. Install new bellows clamps (wire ties) (11) (**Figure 7-20, Page 7-11**).
17. For ease of assembly and to prevent corrosion, apply a light coat of anti-seize and lubricating compound to the ball joint threads.
18. Install the two nuts (12) and drag links (19). Tighten drag link (19) against nut (12) to 20 ft-lb (27 N·m) (**Figure 7-10, Page 7-8 and Figure 7-20, Page 7-11**).
19. Apply a light coat of anti-seize and lubricating compound to the drag link threads.
20. Install the two nuts (12) and ball joints (23) to the drag links (19). Tighten to 20 ft-lb (27 N·m) (**Figure 7-20, Page 7-11**).
21. Apply a light coat of anti-seize compound to the universal joint and install it on the pinion. Tighten the bolt to 15 ft-lb (20 N·m).

RACK AND PINION INSTALLATION

1. For ease of assembly and to prevent corrosion, apply a light coat of anti-seize and lubricating compound to the end of the steering column U-joint.
2. Align the flat portion of the compound joint shaft spline with the bolt hole in the universal joint and then slide the shaft into the universal joint. Install the bolt and lock washer and tighten to 15 ft-lb (20.3 N·m).
3. Position the steering gear box assembly on the vehicle frame and attach the steering U-joint to the gear box assembly. Install the bolts (20), washers (21) and nuts (22). Using a crisscross pattern, tighten the four nuts to 20 ft-lb (27.12 N·m) (**Figure 7-20, Page 7-11**).
4. Install the bolt and lockwasher on the upper universal joint and tighten it to 15 ft-lb (20 N·m).
5. Check all universal joint bolts for proper torque of 15 ft-lb (20 N·m).
6. Adjust the toe-in. **See Toe-in Adjustment on page 7-14.**
7. Inspect the brake hoses at the front wheels. When turning the steering wheel all the way from left to right and back again, the hoses should not come in contact with any component, especially the wheels or tires.

FRONT SUSPENSION

Read **WARNING** on page 7-1.

LUBRICATION

Two grease fittings are provided (one for each kingpin). Lubricate these fittings semi-annually with the proper lubricant. **See Periodic Lubrication Schedule, Section 10, Page 10-4.**

CAUTION

- To ensure proper lubrication of the front suspension, raise front of vehicle to lubricate. **See WARNING on page 7-1.**

WHEEL ALIGNMENT

Wheel alignment is limited to adjusting the toe-in of the front wheels. **See Toe-in Adjustment on page 7-14.**
See also following NOTE.

NOTE: Prior to making any front suspension adjustments, inspect components for wear or damage and repair or replace as necessary.

Toe-in Adjustment

1. On a level surface, roll the vehicle forward, then stop. Make sure the front wheels are pointed straight ahead. Do not turn the steering wheel again during this procedure.
2. On each front tire, mark (as closely as possible) the center of the tread face that is oriented toward the rear of the vehicle. The marks should be at the same height as the center of each hub.
3. Measure the distance between the marks on the rear-facing surfaces of the tires, and then roll the vehicle forward one and one-half wheel revolutions until the marks appear on the forward-facing surfaces of the tires at the same height as the center of the hub.

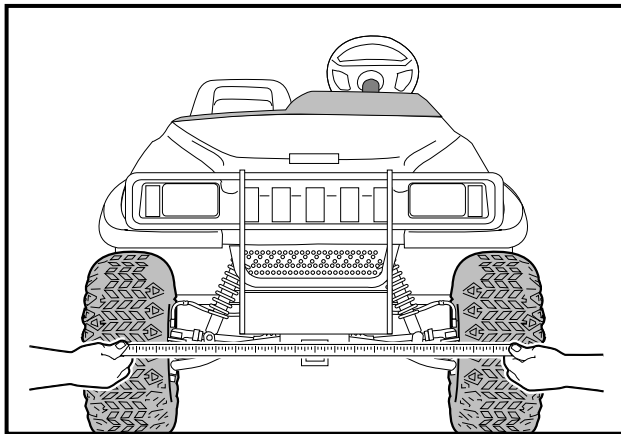

Figure 7-25 Measure Toe-in

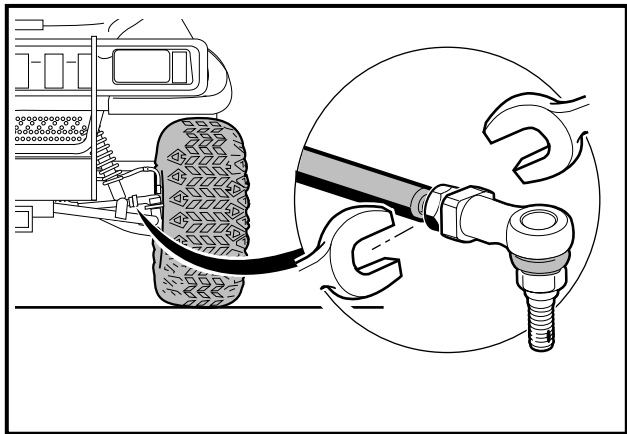

Figure 7-26 Adjust Toe-in

4. Measure the distance between the marks on the forward-facing surfaces of the tires (**Figure 7-25, Page 7-14**).

NOTE: The front measurement must be less than the rear measurement.

5. Subtract the measurement on the front of the tires from the measurement on the rear of the tires. The difference is the toe-in. Proper toe-in is 11/16 inch \pm 3/8 of an inch (18 mm \pm 10 mm).

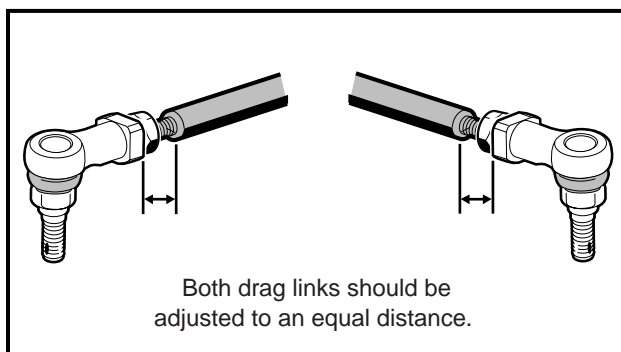

Figure 7-27 Adjust Toe-in

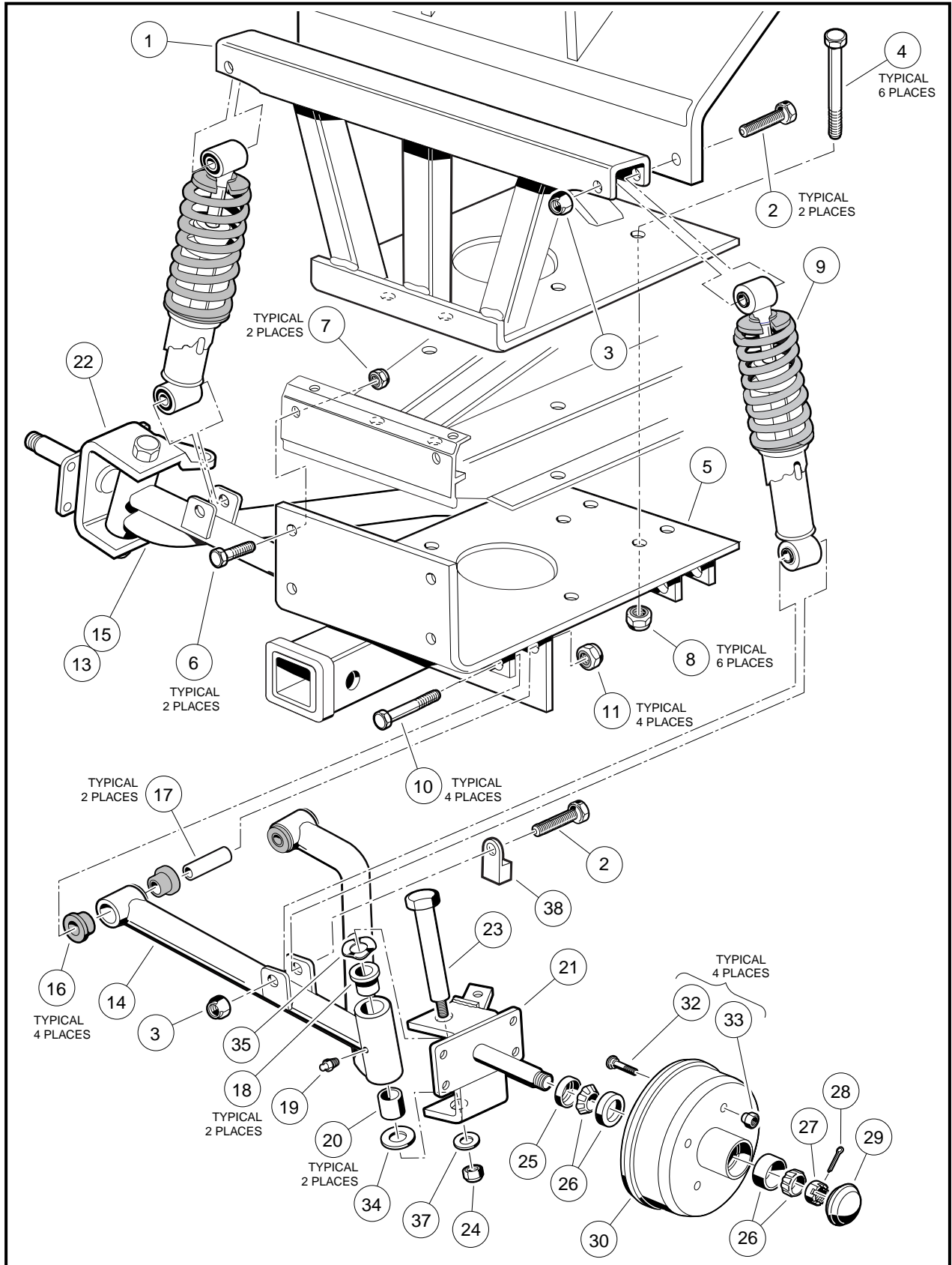

Figure 7-28 Pioneer 1200 Vehicle Front Suspension

Toe-in Adjustment, Continued:

6. If adjustment is necessary:
 - 6.1. Remove the two cotter pins (18) (**Figure 7-20, Page 7-11**).
 - 6.2. Remove the lock nuts (24) (**Figure 7-20, Page 7-11**).
 - 6.3. Rotate both of the ball joints an equal amount. To increase the toe-in, rotate both of the ball joints counterclockwise. To decrease the toe-in, rotate both of the ball joints clockwise. Maintain an equal distance from the ball joint to the end of the threads on each drag link (**Figure 7-27, Page 7-14**).
 - 6.4. Tighten the lock nuts (24) to 18 ft-lb (24.4 N·m) (**Figure 7-20, Page 7-11**).
7. Check the toe-in. If toe-in is not adjusted properly, repeat step 6.
8. Tighten nuts (12) to 20 ft-lb (27 N·m) and recheck toe-in (**Figure 7-20, Page 7-11**). If an adjustment is necessary, continue repeating step 6 until the toe-in adjustment is correct.
9. Install **new** cotter pins (18) (**Figure 7-20, Page 7-11**).
10. After toe-in adjustment is made and with wheels in the straight ahead position, the steering wheel should be at the center of its travel. If the steering wheel is not at the center of travel, remove the steering wheel and install it in the correct orientation. **See Steering Wheel on page 7-1.**
11. Inspect the brake hoses at the front wheels. When turning the steering wheel all the way from left to right and back again, the hoses should not come in contact with any component, especially the wheels or tires.

FRONT SUSPENSION COMPONENTS

Read **WARNING** on page 7-1.

KINGPIN AND STEERING SPINDLE REMOVAL

1. Remove the front brake drum. **See Rear Wheel Brake Drum Removal, Section 6, Page 6-8.**
2. Remove cotter pin (18) and nut (24), then remove the ball joint from the spindle assembly (**Figure 7-20, Page 7-11**).
3. Remove the four Torx head bolts, washers and lock nuts securing the brake cluster to the spindle assembly.
4. Rest the brake cluster on the A-arm as shown (**Figure 7-29, Page 7-16**). Ensure that there is no strain on the brake hose. **See following WARNING.**

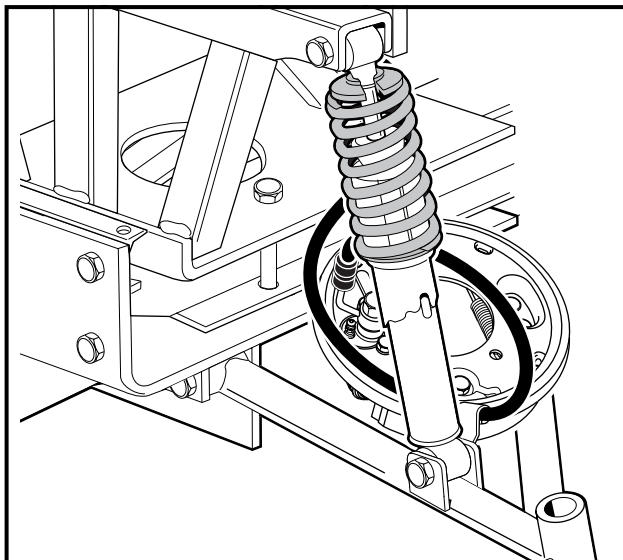

Figure 7-29 Rest Brake Cluster on A-arm

▲ WARNING

- **Strain on the brake hose or the brake hose fittings can result in damage to the hose or fittings, causing a leak in the hydraulic system, diminished brake performance, or brake failure.**
5. Remove the nut (24) and washer (37) from kingpin (23) and remove the kingpin (**Figure 7-28, Page 7-15**).
 6. Remove the thrust washer (34) (**Figure 7-28, Page 7-15**).
 7. Remove the wave washer (35) and inspect it. If the washer is broken or has a wave bottom to wave crest height dimension of less than .040 inch (0.10 cm), it must be replaced (**Figure 7-28, Page 7-15**).
 8. Slide the spindle (21) off of the A-arm (14) (**Figure 7-28, Page 7-15**).
 9. Repeat the procedure for the other front wheel if necessary.

KINGPIN AND STEERING SPINDLE INSTALLATION

1. Inspect all parts and replace them as necessary.
2. Inspect the kingpin (23) and spindle (21). If either are worn or damaged, it must be replaced (**Figure 7-28, Page 7-15**).
3. Inspect the bushings (18 and 20) (**Figure 7-28, Page 7-15**). If the bushings are worn or damaged, remove them and press in new ones. **See following NOTE.**

NOTE: If the bushings are replaced, ream new bushings to .750-.752 of an inch (19.05-19.10 mm) in diameter. The reamer should be long enough to ream both bushings from one direction.

4. Install the spindle (21) onto the A-arm (14) (**Figure 7-28, Page 7-15**).
5. Install the thrust washer (34), wave washer (35) and kingpin (23) (**Figure 7-28, Page 7-15**).
6. Install the washer (37) and a **new** lock nut (24). Tighten to 18 ft-lb (24.4 N·m) (**Figure 7-28, Page 7-15**).
7. Insert the ball joint (23) into the spindle assembly (**Figure 7-20, Page 7-11**).
8. Install the lock nut (24) and tighten to 18 ft-lb (24.4 N·m) (**Figure 7-20, Page 7-11**).
9. Install a **new** cotter pin (18) and bend it to secure it to the ball joint (**Figure 7-20, Page 7-11**).
10. Using a grease gun, apply grease to the grease fitting (19) in the A-arm (14) (**Figure 7-28, Page 7-15**). **See Lubrication on page 7-13.**
11. Install the brake cluster. **See Front Brake Cluster Installation, Section 6, Page 6-17.**
12. Repeat the procedure for the other front wheel if necessary.
13. Check toe-in adjustment and make adjustments if necessary. **See Toe-in Adjustment on page 7-14.**
14. Inspect the brake hoses at the front wheels. When turning the steering wheel all the way from left to right and back again, the hoses should not come in contact with any component, especially the wheels or tires.

A-ARM REMOVAL

1. Remove the front brake cluster. **See Front Brake Cluster Removal, Section 6, Page 6-17.**
2. Remove cotter pin (18) and nut (24), then remove the ball joint from the spindle assembly (**Figure 7-20, Page 7-11**).
3. Remove the nut (24) and washer (37) from the kingpin (23) and remove the kingpin (**Figure 7-28, Page 7-15**).
4. Remove the thrust washer (34) (**Figure 7-28, Page 7-15**).
5. Remove the wave washer (35) and inspect it. If the washer is broken or has a wave bottom to wave crest height dimension of less than .040 inch (0.10 cm), it must be replaced (**Figure 7-28, Page 7-15**).

6. Slide the spindle (21) off of the A-arm (14) **(Figure 7-28, Page 7-15)**.
7. Remove the lower shock absorber mounting bolt (2) and nut (3) from the A-arm **(Figure 7-28, Page 7-15)**.
8. Remove the two bolts (10) and two nuts (11) securing the A-arm to the front suspension mounting plate **(Figure 7-28, Page 7-15)**.
9. Remove the A-arm from the suspension mounting plate.
10. Repeat the procedure for the other front wheel if necessary.

A-ARM INSTALLATION

1. Prior to installation, inspect the bushings (16) and sleeves (17) in the A-arm and replace them if necessary **(Figure 7-28, Page 7-15)**.
2. Inspect the bushings (18 and 20) **(Figure 7-28, Page 7-15)**. If the bushings are worn or damaged, remove them and press in new ones. **See following NOTE.**

NOTE: If the bushings are replaced, ream new bushings to .750-.752 (3/4 inch) (19.05/19.10 mm) in diameter. The reamer should be long enough to ream both bushings from one direction.

3. Install the A-arm in the reverse order of removal. Tighten the A-arm nuts (11) to 20 ft-lb (27 N·m) **(Figure 7-28, Page 7-15)**.
4. Install the spindle (21) onto the A-arm (14) **(Figure 7-28, Page 7-15)**.
5. Install the thrust washer (34), wave washer (35) and kingpin (23) **(Figure 7-28, Page 7-15)**.
6. Install the washer (37) and a **new** lock nut (24). Tighten to 18 ft-lb (24.4 N·m) **(Figure 7-28, Page 7-15)**.
7. Insert the ball joint (23) into the spindle assembly **(Figure 7-20, Page 7-11)**.
8. Install the lock nut (24) to secure the ball joint to the spindle and tighten to 18 ft-lb (24.4 N·m) **(Figure 7-20, Page 7-11)**.
9. Install a **new** cotter pin (18) and bend it to secure it to the ball joint **(Figure 7-20, Page 7-11)**.
10. Using a grease gun, apply grease to the grease fitting (19) in the A-arm (14) **(Figure 7-28, Page 7-15)**. **See Lubrication on page 7-13.**
11. Install the brake cluster. **See Front Brake Cluster Installation, Section 6, Page 6-17.**
12. Repeat the procedure for the other front wheel if necessary.
13. Check toe-in adjustment and make adjustments if necessary. **See Toe-in Adjustment on page 7-14.**
14. Inspect the brake hoses at the front wheels. When turning the steering wheel all the way from left to right and back again, the hoses should not come in contact with any component, especially the wheels or tires.

SHOCK ABSORBER REMOVAL AND INSPECTION

1. Place chocks at the rear wheels, set the park brake, and lift the front of the vehicle with a chain hoist or floor jack. Place jack stands under the front frame tubes to support the vehicle and lower the floor jack or chain hoist so that the vehicle is resting on the jack stands.
2. Inspect the shock absorbers for damage or fluid leakage on the shock absorber body. Leaking or damaged shock absorbers should be replaced.
3. Remove the bolt (2) and nut (9) attaching the shock absorber to the A-arm **(Figure 7-30, Page 7-19)**.
4. Remove the steering stop weldment (38) and brake hose support bracket from the A-arm **(Figure 7-30, Page 7-19)**.

5. Remove the nut (3) and bolt (2) attaching the shock absorber to the shock and gear support (**Figure 7-28, Page 7-15**).
6. Remove the shock absorber.

SHOCK ABSORBER INSTALLATION

1. Install the shock absorber by reversing the removal procedure.
2. Tighten the nuts to 20 ft-lb (27 N·m).
3. Inspect the brake hoses at the front wheels. When turning the steering wheel all the way from left to right and back again, the hoses should not come in contact with any component, especially the wheels or tires.

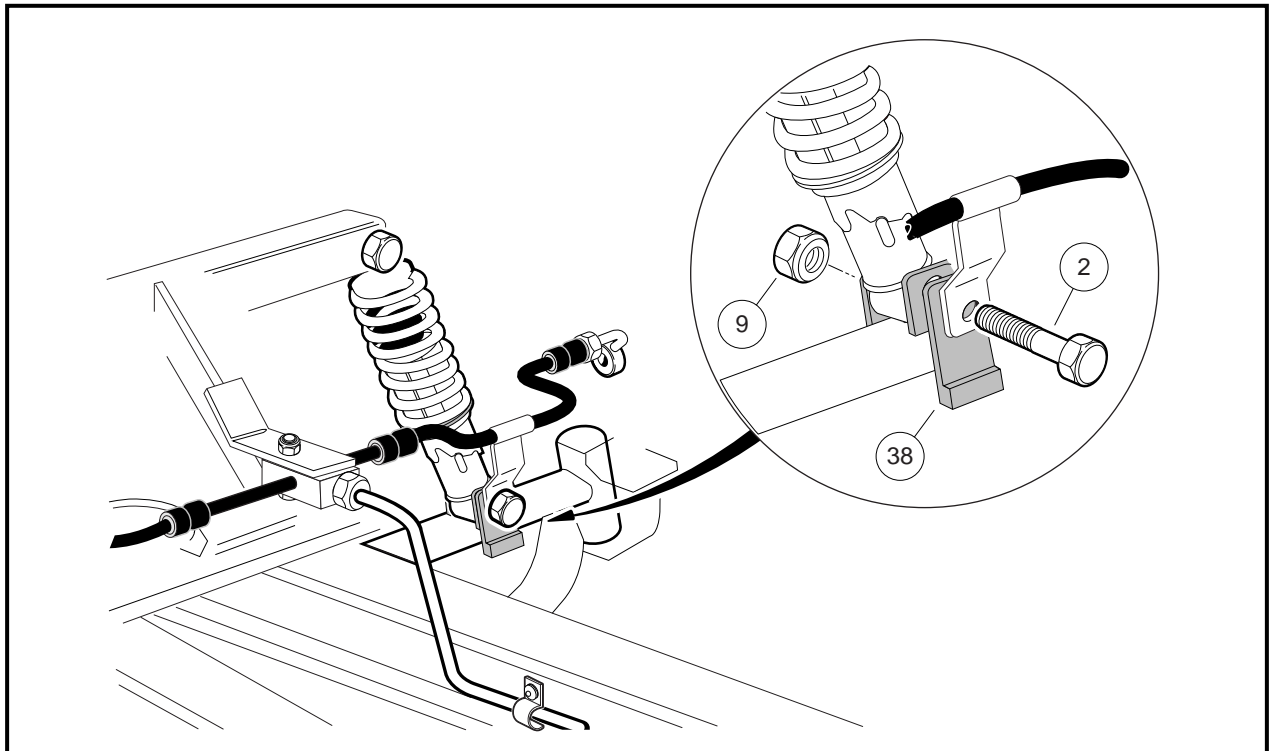

Figure 7-30 Shock Absorber Removal

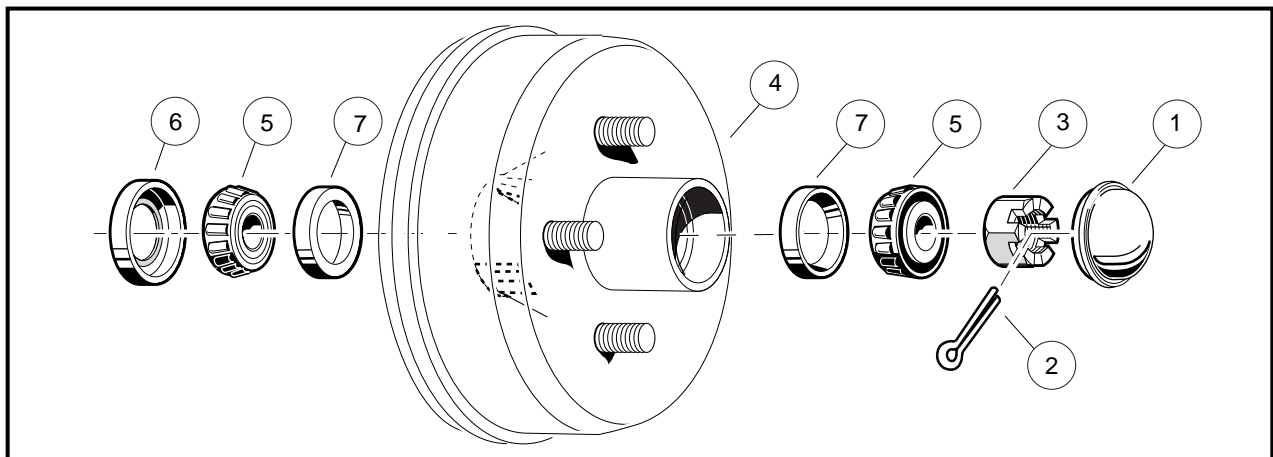

Figure 7-31 Front Wheel Bearings and Hub

FRONT WHEEL BEARINGS AND HUBS

Read **WARNING** on page 7-1.

FRONT WHEEL FREE PLAY INSPECTION

1. Raise the front of the vehicle.
2. Using your hands, attempt to rock the wheel and hub assembly back and forth on the spindle. If there is any observable movement of the wheel and hub on the spindle, remove dust cap (1) and cotter pin (2) and then tighten the spindle nut (3) until the bearing (5) fully seats in the bearing cup (7).
3. Loosen spindle nut one cotter pin position. If the hub does not turn freely, loosen spindle nut one more cotter pin position.
4. Install a new cotter pin (2). If movement continues, replace the wheel bearings (5) as required (**Figure 7-31, Page 7-19**).

FRONT WHEEL BEARINGS AND HUB REMOVAL

See **Front Wheel Brake Drum Removal, Section 6, Page 6-7**.

FRONT WHEEL BEARINGS AND HUB INSTALLATION

See **Front Wheel Brake Drum Installation, Section 6, Page 6-14**.

SECTION 8 – WHEELS AND TIRES

▲ WARNING

- Only trained technicians should repair or service this vehicle. Anyone doing even simple repairs or service should have knowledge and experience in electrical and mechanical repair.
- Follow all procedures exactly as stated in this manual, and heed all DANGER, WARNING, and CAUTION statements in this manual as well as those affixed to the vehicle.
- Wear safety glasses or approved eye protection while servicing vehicle. Wear a full face shield and rubber gloves when working with batteries.
- Turn key switch OFF, place Forward/Reverse handle in the NEUTRAL position, and remove key before servicing the vehicle.
- Moving parts! Do not attempt to service the vehicle while the engine is running.
- Use insulated tools when working near batteries or electrical connections. Use extreme caution to avoid shorting of components or wiring.
- To avoid unintentionally starting the vehicle:
 - Disconnect battery cables, negative cable (–) first.
 - Disconnect the spark plug wire from the spark plug.
- Frame ground – Do not allow tools or other metal objects to contact frame when disconnecting battery cables or other electrical wiring. Never allow a positive wire to touch the vehicle frame, engine, or any other metal component.
- Lift only one end of the vehicle at a time. Before lifting, set the park brake when lifting the front of the vehicle, unload the cargo bed, and chock the wheels that remain on the floor. Use a suitable lifting device (chain hoist or hydraulic floor jack) with 1000 lb. (454 kg) minimum lifting capacity. Do not use lifting device to hold vehicle in raised position. Use approved jack stands of proper weight capacity to support the vehicle.

GENERAL INFORMATION

Maximum tire life and good vehicle handling qualities are directly related to proper wheel and tire care.

- Keep tires properly inflated as follows:

All Terrain Tread	Front: 7-11 psi (48-76 kPa) Rear: 14-18 psi (97-124 kPa)
Turf Tread	Front: 12-16 psi (83-110 kPa) Rear: 16-20 psi (110-138 kPa)
Traks Max II Tread	Front: 14-16 psi (97-110 kPa) Rear: 18-20 psi (124-138 kPa)

- Keep lug nuts properly tightened.
- Keep the front end properly aligned and adjusted.

WHEELS

Read **WARNING** on page 8-1.

WHEEL REMOVAL

1. Slightly loosen the lug nuts on the wheel to be removed.
2. Raise the end of the vehicle from which the wheel is to be removed. Make sure the wheels are off the ground. **See WARNING on page 8-1.**
3. Remove the lug nuts and remove the wheel.

WHEEL INSTALLATION

1. Install wheel(s) and tighten the lug nuts (using a crisscross pattern) until they are snug. **See following NOTE.**

NOTE: Traks Max II tires are directional. For optimum performance on muddy terrain, install all four tires as shown (**Figure 8-1, Page 8-2**).

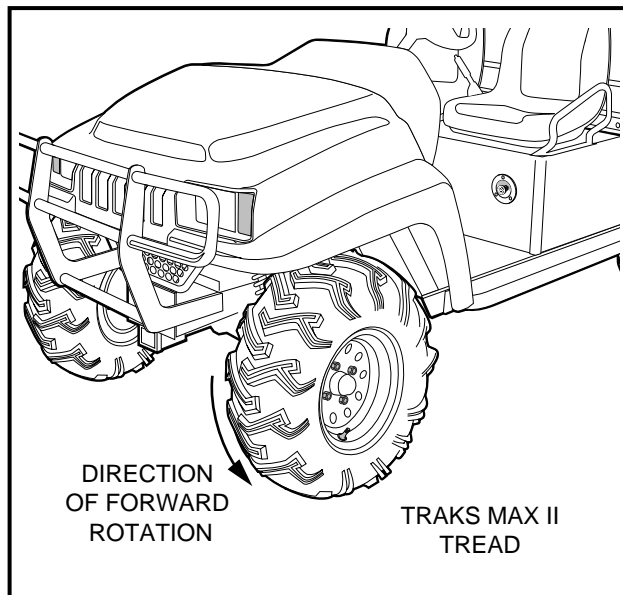

Figure 8-1 Tire Rotation

2. Lower the vehicle and finish tightening the lug nuts (using a crisscross pattern) to 55 ft-lb (74.6 N-m).
3. Inspect the brake hoses at the front wheels. When turning the steering wheel all the way from left to right and back again, the hoses should not come in contact with any component, especially the wheels or tires.
4. Check the park brake cables. The cables should not come in contact with either of the rear wheels or tires.

TIRES

Read **WARNING** on page 8-1.

TIRE REMOVAL

NOTE: Tire must be removed or installed from the valve stem side of the rim.

1. Remove the tire and wheel assembly from the vehicle. **See Wheel Removal on page 8-2.**
2. Remove the valve cap and valve core and allow air to escape from the tire.
3. Use a tire machine to remove the tire from the rim.

TIRE REPAIR

1. Determine the location and cause of the air leak.
 - 1.1. Remove the wheel as instructed. **See Wheel Removal on page 8-2.** Inflate the tire to the recommended tire pressure.
 - 1.2. Immerse the tire in water and then mark the point where bubbles are formed by escaping air.
 - 1.3. Determine the cause of the air leak and repair as required. **See following NOTE.**

NOTE: An air leak could be due to a punctured tire, faulty valve core, improperly seated valve stem, or improperly seated tire bead.

Small holes in the tire can be plugged using a standard automotive tubeless tire repair kit available at auto supply stores.

TIRE INSTALLATION

1. Use a tire machine to install the new tire on the rim.
2. Adjust air pressure in the tire to the recommended pressure and immerse the wheel and tire assembly in water to make sure there are no leaks.
3. Install the wheel. **See Wheel Installation on page 8-2.**

SECTION 9 – REAR SUSPENSION

▲ WARNING

- Only trained technicians should repair or service this vehicle. Anyone doing even simple repairs or service should have knowledge and experience in electrical and mechanical repair.
- Follow all procedures exactly as stated in this manual, and heed all DANGER, WARNING, and CAUTION statements in this manual as well as those affixed to the vehicle.
- Wear safety glasses or approved eye protection while servicing vehicle. Wear a full face shield and rubber gloves when working with batteries.
- Turn key switch OFF, place Forward/Reverse handle in the NEUTRAL position, and remove key prior to servicing.
- Do not wear loose clothing. Remove jewelry such as rings, watches, chains, etc. before servicing vehicle.
- Use insulated tools when working near batteries or electrical connections. Use extreme caution to avoid shorting of components or wiring.
- Moving parts! Do not attempt to service the vehicle while the engine is running.
- Hot! Do not attempt to service hot engine, or exhaust system. Failure to heed this warning could result in severe burns.
- To avoid unintentionally starting the vehicle:
 - Disconnect battery cables, negative cable (-) first.
 - Disconnect the spark plug wire from the spark plug.
- Frame ground – Do not allow tools or other metal objects to contact frame when disconnecting battery cables or other electrical wiring. Never allow a positive wire to touch the vehicle frame, engine, mounting plate, or any other metal component.
- Lift only one end of the vehicle at a time. Before lifting, set the park brake when lifting the front of the vehicle, unload the cargo bed and chock the wheels that remain on the floor. Use a suitable lifting device (chain hoist or hydraulic floor jack) with 1000 lb. (454 kg) minimum lifting capacity. Do not use lifting device to hold vehicle in raised position. Use approved jack stands of proper weight capacity to support the vehicle.

GENERAL INFORMATION

The rear suspension and powertrain of the Pioneer 1200 vehicle move independently from the vehicle frame. The suspension includes two multi-leaf springs controlled by two hydraulic shock absorbers mounted between the spring mounting plate and the frame. The engine is mounted on an engine mounting plate that moves with the suspension. At the front of the mounting plate, a snubber controls mounting plate motion.

SHOCK ABSORBERS

Read WARNING on page 9-1.

SHOCK ABSORBER REMOVAL AND INSPECTION

1. Check shock absorbers (1) for damage or fluid leakage around the lower housing of the shock absorber body. Replace damaged or leaking shock absorbers (**Figure 9-1, Page 9-2**).

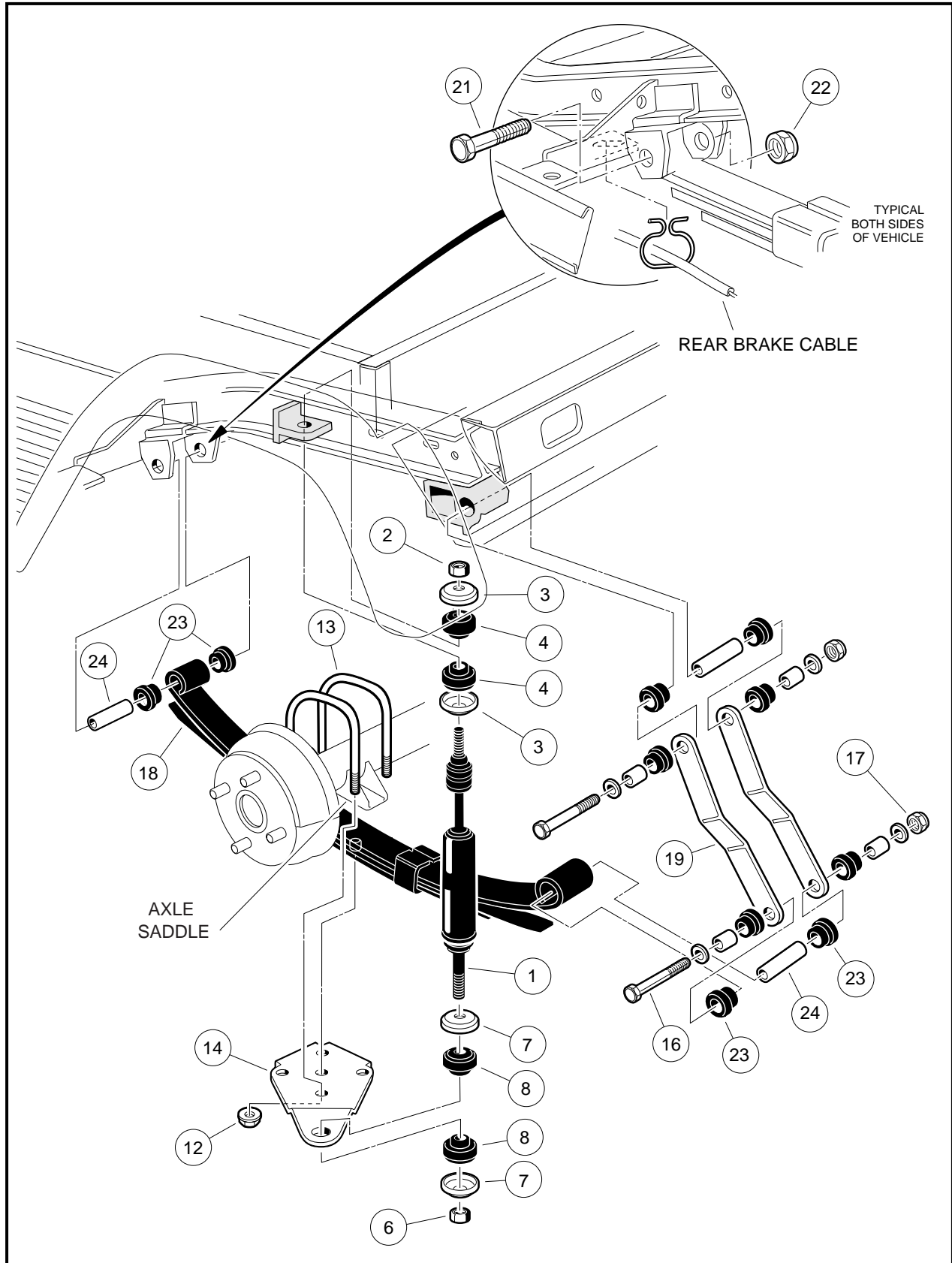

Figure 9-1 Rear Suspension

Shock Absorber Removal and Inspection, Continued:

2. To remove a shock absorber (1), remove the nut (2), cup washer (3) and rubber bushing (4) from the upper shock absorber stem (**Figure 9-1, Page 9-2**).
3. Remove lower mounting hardware (6, 7 and 8) on shock absorber lower mount (**Figure 9-1, Page 9-2**). **See also Figure 9-2, Page 9-3.**
4. Compress the shock absorber to remove it.

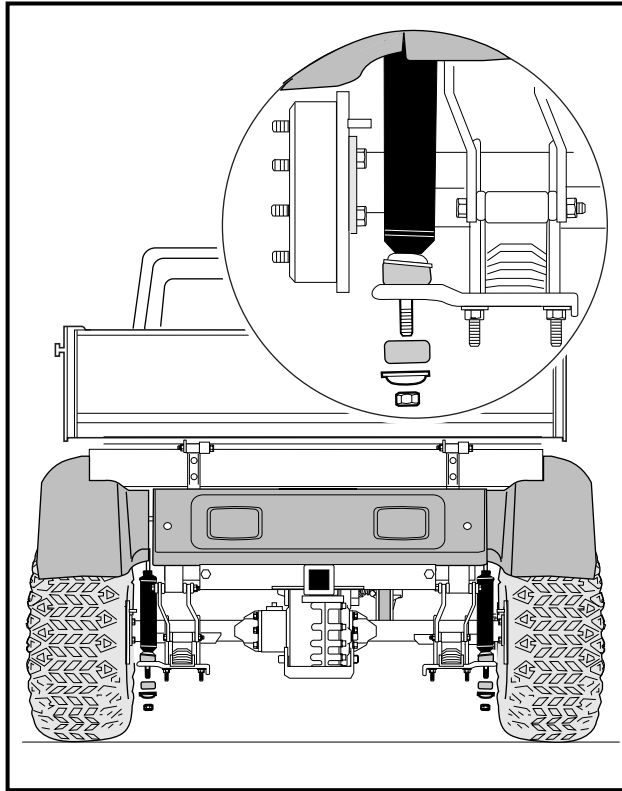

Figure 9-2 Remove Shock Absorbers

SHOCK ABSORBER INSTALLATION

NOTE: When installing shock absorbers, make sure front shocks have identical part numbers and rear shocks have identical part numbers.

1. To install, reverse the removal procedure.
2. On the upper shock absorber mount, tighten nut (2) until rubber bushing (4) expands to the same diameter as the cup washer (8).
3. On the lower shock absorber mount, install mounting hardware. Tighten the nut (6) until the rubber bushing (8) expands to the same diameter as the cup washer (7) (**Figure 9-1, Page 9-2**).

MULTI-LEAF SPRINGS

Read **WARNING** on page 9-1.

MULTI-LEAF SPRING REMOVAL

1. Remove shock absorbers. **See Shock Absorber Removal and Inspection on page 9-1.**
2. Loosen the lug nuts on wheel(s) to be removed.

- Place chocks in front of the front wheels and lift rear of vehicle with a chain hoist or floor jack. If using floor jack, place jack under transaxle as shown (**Figure 9-3, Page 9-4**).
- Position jack stands under the two side stringers as shown (**Figure 9-4, Page 9-4**). Lower the floor jack to let the jack stands support the vehicle. See **WARNING** on page 9-1.

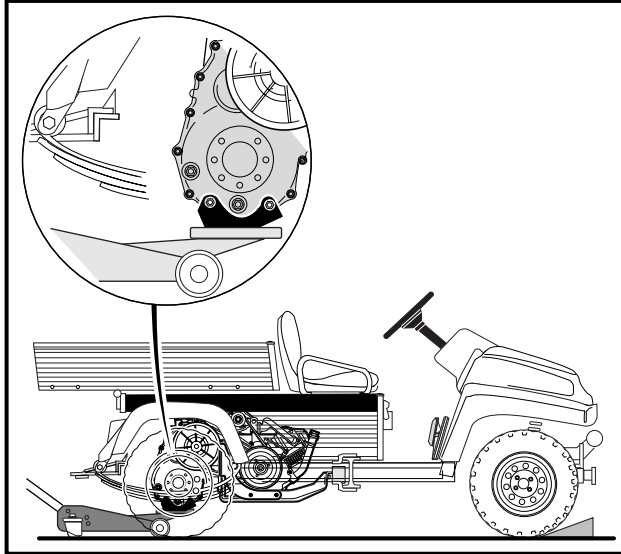

Figure 9-3 Correct Positioning of Floor Jack

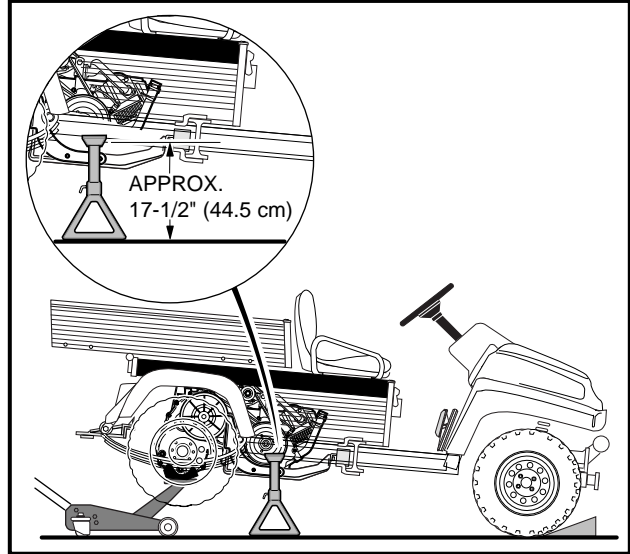

Figure 9-4 Correct Positioning of Jack Stands

- Remove tire and wheel assembly on the side from which the spring is to be removed. Thread one lug nut onto a stud on the rear hub. This will keep the brake drum on the hub.
- The jack stands should be supporting the vehicle and the floor jack should be supporting the rear suspension. Lower the floor jack until the leaf springs are unloaded but the floor jack is still supporting the axle.
- Remove the locknuts (12) attaching the U-bolts (13) to the shock mount bracket (14) (**Figure 9-1, Page 9-2**).
- Remove bolt (16) and locknut (17) attaching the leaf spring (18) to the rear shackles (19) (**Figure 9-1, Page 9-2**).
- Allow rear of leaf spring (18) to rest on the ground and remove the bolt (21) and locknut (22) attaching the front of the spring to the vehicle frame (**Figure 9-1, Page 9-2**). Remove spring from vehicle.
- Inspect the rubber bushings (23) and steel sleeves (24) in the spring eyes and replace them if they are worn or damaged (**Figure 9-1, Page 9-2**).

MULTI-LEAF SPRING INSTALLATION

NOTE: When installing leaf springs, make sure that both springs have identical part numbers.

- Install rubber bushings (23) and steel sleeves (24) into leaf spring eyes if bushings were removed (**Figure 9-1, Page 9-2**).
- Place front of leaf spring (18) into front spring mounts and insert the grade eight bolt (21) through mount and leaf spring eye. Install locknut (22) and tighten to 15 ft-lb (20.3 N·m) (**Figure 9-1, Page 9-2**).

⚠ CAUTION

- Use only grade eight bolts for the front mounts of the leaf springs.

- Align the other end of leaf spring with the holes in the spring shackles (19). Insert bolt (16) through leaf spring eye and shackles. Install locknut (17) and tighten to 15 ft-lb (20.3 N-m). Lower transaxle onto leaf spring (18) (**Figure 9-1, Page 9-2**).

⚠ CAUTION

- When placing transaxle on spring, be sure to position locating bolt on the spring in the locating hole in the transaxle saddle.
- Install shock mount bracket (14) onto locating bolt at bottom center of leaf spring (**Figure 9-1, Page 9-2**). See preceding **CAUTION**.
 - Install U-bolts (13) and locknuts (12). Tighten locknuts in a crisscross pattern to 35 ft-lb (47.5 N-m) (**Figure 9-1, Page 9-2**).
 - Install shock absorber. See **Shock Absorber Installation on page 9-3**.

SNUBBER

Read **WARNING** on page 9-1.

SNUBBER REMOVAL

- Support the powertrain with a floor jack under the engine mounting plate so that the snubber is raised slightly and does not rest on the vehicle frame.
- Working from above, remove the two bolts (2) and two locknuts (1) securing the snubber bracket to the engine mounting plate (**Figure 9-5, Page 9-5**).
- Slide snubber and bracket assembly toward battery to remove it from vehicle. See following **CAUTION**.

⚠ CAUTION

- With snubber removed, the powertrain must be supported. Loss of support could result in damage to the vehicle or personal injury.

SNUBBER INSTALLATION

- Install in the reverse order of removal.
- Tighten snubber bracket mounting nuts (1) to 13 ft-lb (17.6 N-m) (**Figure 9-5, Page 9-5**).

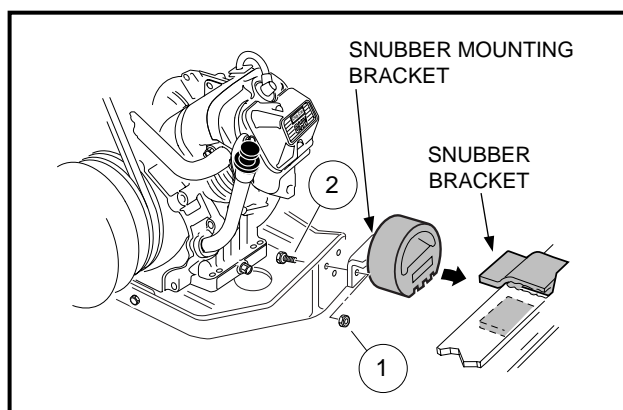

Figure 9-5 Snubber Brackets

SECTION 10 – PERIODIC MAINTENANCE

▲ DANGER

- **Battery – Explosive gases! Do not smoke. Keep sparks and flames away from the vehicle and service area. Ventilate when charging or using in an enclosed space. Wear a full face shield and rubber gloves when working on or near batteries.**
- **Battery – Poison! Contains acid! Causes severe burns. Avoid contact with skin, eyes, or clothing. Antidotes:**
 - **External: Flush with water. Call a physician immediately.**
 - **Internal: Drink large quantities of water. Follow with milk of magnesia or vegetable oil. Call a physician immediately.**
 - **Eyes: Flush with water for 15 minutes. Call a physician immediately.**
- **Gasoline – Flammable! Explosive! Do not smoke. Keep sparks and flames away from vehicle and service area. Service only in a well-ventilated area.**
- **Do not operate vehicle in an enclosed area without proper ventilation. The engine produces carbon monoxide, which is an odorless, deadly poison.**

▲ WARNING

- **Only trained technicians should repair or service the vehicle. Anyone doing even simple repairs or service should have knowledge and experience in electrical and mechanical repair.**
- **Follow the procedures exactly as stated in this manual, and heed all DANGER, WARNING, and CAUTION statements in this manual as well as those affixed to the vehicle.**
- **Improper use of the vehicle or failure to properly maintain it could result in decreased vehicle performance or severe personal injury.**
- **Any modification or change to the vehicle that affects the stability or handling of the vehicle, or increases maximum vehicle speed beyond factory specifications, could result in severe personal injury or death.**
- **Check the owner's manual for proper location of all vehicle warning decals and make sure they are in place and are easy to read.**
- **Wear safety glasses or approved eye protection when servicing the vehicle.**
- **Do not wear loose clothing. Remove jewelry such as rings, watches, chains, etc. before servicing vehicle.**
- **Moving parts! Do not attempt to service the vehicle while it is running.**
- **Hot! Do not attempt to service hot engine or exhaust system. Failure to heed this warning could result in severe burns.**
- **Use insulated tools when working near batteries or electrical connections. Use extreme caution to avoid shorting of components or wiring.**
- **Frame ground – Do not allow tools or other metal objects to contact frame when disconnecting battery cables or other electric wiring. Never allow a positive wire to touch the frame, engine, or any other metal component.**
- **Turn the key switch to OFF, remove the key, chock the wheels and place the Forward/Reverse handle in NEUTRAL prior to servicing the vehicle.**
- **To avoid unintentionally starting the vehicle:**
 - **Disconnect battery cables, negative cable (–) first (Figure 10-1, Page 10-2).**
 - **Disconnect the spark plug wire from the spark plug.**
 - **Turn fuel shut-off valve to closed (OFF) (Figure 10-5, Page 10-7).**

- Do not work on vehicle powertrain or under the cargo bed when it is loaded.
- The prop rod on the vehicle should be securely engaged prior to servicing. Remove all cargo before raising the bed. Do not disengage prop rod until all persons are clear of cargo bed area. Do not drop cargo bed; lower gently and keep entire body clear. Failure to follow these instructions could result in severe injury.
- A hydraulic bed lift system is under pressure. Wear a face shield and use extreme caution when servicing it.
- Lift only one end of the vehicle at a time. Before lifting, set the park brake when lifting the front of the vehicle, unload the cargo bed, and chock the wheels that remain on the floor. Use a suitable lifting device (chain hoist or hydraulic floor jack) with 1000 lb. (454 kg) minimum lifting capacity. Do not use lifting device to hold vehicle in raised position. Use approved jack stands of proper weight capacity to support the vehicle.

GENERAL INFORMATION

Read DANGER and WARNING on pages 10-1 and 10-2.

To ensure trouble-free vehicle performance, it is very important to follow an established preventive maintenance program (regularly scheduled service). See **Periodic Service Schedule on page 10-3**. Regular and consistent vehicle maintenance can prevent vehicle down-time and expensive repairs that result from neglect. Any vehicle not functioning correctly should be removed from use until it is properly repaired. This will prevent further damage to the vehicle and avoid the possibility of injury due to unsafe conditions.

Contact your local Pioneer dealer to perform all repairs and semiannual and annual periodic service.

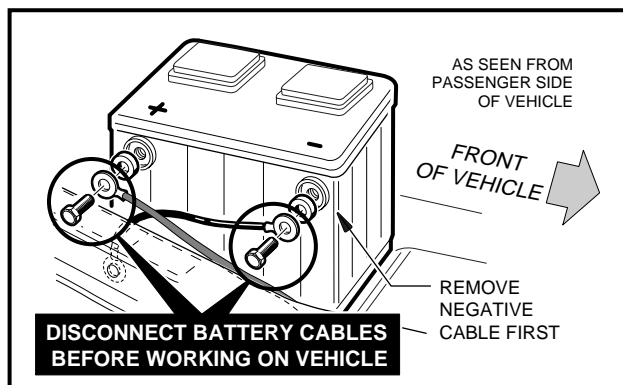

Figure 10-1 Battery Cable Removal

DAILY PRE-OPERATION SAFETY CHECKLIST

Read DANGER and WARNING on pages 10-1 and 10-2.

Inspect and drive the vehicle, using the Pre-Operation Checklist and Performance Inspection in the Pioneer Owner's Manual as a guide to check the following items.

- Vehicle warning decals
- Brake system
- Park brake
- Reverse warning buzzer
- Steering and linkages
- Proper acceleration and maximum speed

- Differential lock cable

In addition, check the items listed below:

- Tires: Visually inspect for wear, damage and proper inflation.
- Exhaust system: Check for leaks.
- Forward/Reverse shifter: Check for proper operation. **See Controls and Indicators in the Pioneer 1200 Owner’s Manual.**
- Fuel system: Check fuel tank, lines, cap, pump, fuel filters, and carburetor for fuel leakage.

PERIODIC SERVICE SCHEDULE

Read **DANGER** and **WARNING** on pages 10-1 and 10-2.

WARNING

- **Service, repairs, and adjustments must be made per instructions in this maintenance and service manual.**

NOTE: If the vehicle is constantly subjected to heavy use or severe operating conditions, the preventive maintenance procedures should be performed more often than recommended in the periodic service and lubrication schedules.

Both the Periodic Service Schedule and the Periodic Lubrication Schedule must be followed to keep the vehicle in optimum operating condition.

PERIODIC SERVICE SCHEDULE		
REGULAR INTERVAL	SERVICE	
Monthly service by owner or trained technician	Engine	Check engine oil level; change as required. See Periodic Lubrication Schedule on page 10-4.
		Check engine cooling air intake; visually inspect unshrouded area around engine exhaust for grass and debris, and clean as necessary.
	Tires	Check air pressure and adjust as necessary See Section 8 – Wheels and Tires.
	General vehicle	Wash engine compartment and underside of vehicle. Do not wash engine when hot.
Semiannual service by trained technician only (every 50 hours of operation)	Battery	Clean terminals and wash dirt from casing; check electrolyte level. See Battery, Section 12, Page 12-31.
	Front wheel alignment and toe-in	Check and adjust as required. See Section 7 – Steering and Front Suspension.
	Electrical wiring and connections	Check for tightness and damage.
Periodic Service Schedule continued on next page...		

PERIODIC SERVICE SCHEDULE		
REGULAR INTERVAL	SERVICE	
Semiannual service by trained technician only (every 50 hours of operation), continued	Brake system	Inspect master cylinder, wheel cylinders, and brake lines and hoses for damage or leakage.
		Check park brake cables for damage. Replace as required.
		Check brake shoes and drums; replace as required. See Section 6 – Hydraulic and Park Brake Systems.
Annual service by trained technician only (every 100 hours of operation)	Engine	Check for leaks around gaskets, fill plugs, etc.
		Inspect, clean and gap spark plug; replace if necessary.
	Engine air intake system	Check air filter element; clean or replace if necessary.
		Check clamps for tightness; check hose for cracks.
General vehicle	Check for loose hardware and tighten as required.	
Two year service by trained technician only (every 200 hours of operation).	Fuel filters	Replace

WARNING

- If any problems are found during scheduled inspection or service, do not operate the vehicle until repairs are made. Failure to make necessary repairs could result in fire, property damage, severe personal injury, or death.

PERIODIC LUBRICATION SCHEDULE

Read DANGER and WARNING on pages 10-1 and 10-2.

See Section 2 – Vehicle Specifications for liquid capacities.

PERIODIC LUBRICATION SCHEDULE			
REGULAR INTERVAL	SERVICE	PLACE*	RECOMMENDED LUBRICANT
Semiannually by owner or trained technician (every 50 hours of operation)	Brake pedal shaft bearings	1	Dry Moly Lube (CCI 1012151)
Periodic Lubrication Schedule continued on next page...			

PERIODIC LUBRICATION SCHEDULE			
REGULAR INTERVAL	SERVICE	PLACE*	RECOMMENDED LUBRICANT
Semiannually by owner or trained technician (every 50 hours of operation), continued	Accelerator push rod pivots, mounts, and shifter cable pivots	2	Dry Moly Lube (CCI 1012151)
	Front suspension (2 fittings)	3	Chassis Lube (EP NLGI Grade 2)
	Check/add brake fluid	4	Use ONLY DOT-5 (silicone) Brake Fluid
Annually by trained technician only (every 100 hours of operation)	Check/fill unitized transaxle to plug level	5	31 oz. (.92 liters) 80-90 Wt. API class GL-3 or 80-90 Wt. AGMA class 5 EP gear lubricant
	Inspect front wheel bearings (repack as necessary)	6	Chassis Lube (EP NLGI Grade 2)
First change 100 hours – additional change every 200 hours of operation or annually, whichever comes first	Change engine oil and oil filter	7	32 oz. (.95 liter) without filter; 38 oz. (1.12 liters) with filter See Oil Viscosity on page 10-7.

*(Figure 10-2, Page 10-5).

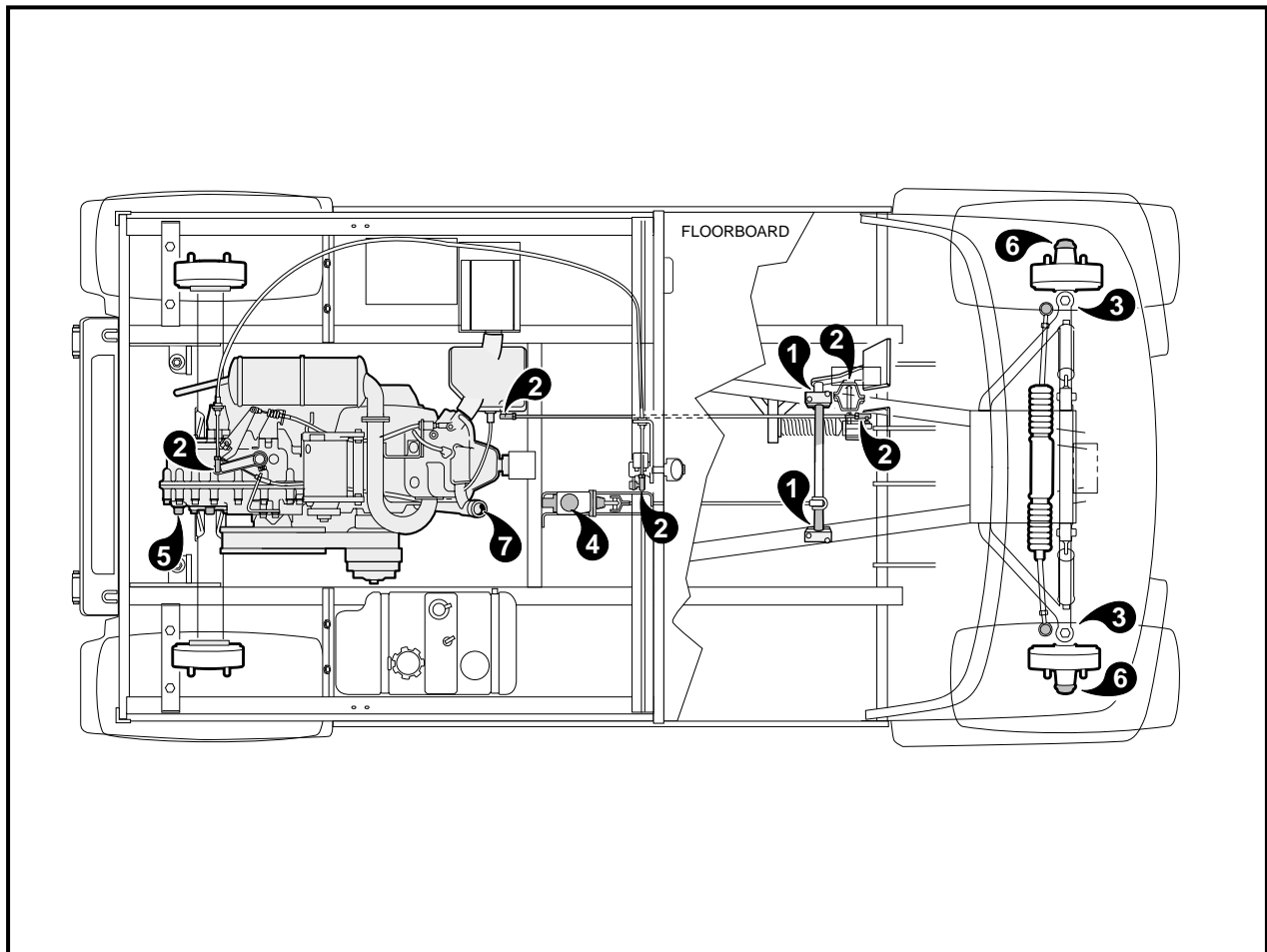

Figure 10-2 Lubrication Points

MASTER CYLINDER

Read **DANGER** and **WARNING** on pages 10-1 and 10-2.

The master cylinder is located under the passenger seat toward the center of the vehicle (**Figure 10-3, Page 10-6**). Raise or remove the seat to check the brake fluid level.

When checking the brake fluid, also inspect the following:

- The presence of brake fluid on the exterior surface of the master cylinder indicates a leak.
- The vent holes in the reservoir cover should be clean and open.
- The reservoir diaphragm should not have holes or other damage.

BRAKE FLUID

Brake fluid level should be within 1/4 inch (6 mm) from top of reservoir (**Figure 10-3, Page 10-6**). Also, brake fluid should be clean with no residue in bottom of reservoir or other evidence of contamination. **See following CAUTION.**

⚠ CAUTION

- Use only DOT-5 (silicone) Brake Fluid. Use of any other type brake fluid is not recommended.

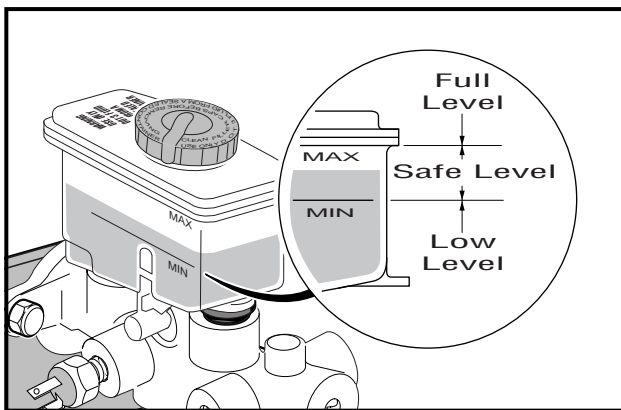

Figure 10-3 Master Cylinder

ENGINE OIL

Read **DANGER** and **WARNING** on pages 10-1 and 10-2.

Even though the oil warning light on the dash should illuminate if the engine oil level is low, the engine oil level should be checked monthly. The vehicle should be on a level surface when checking oil. Do not overfill with oil.

⚠ CAUTION

- Do not remove dipstick while engine is running.

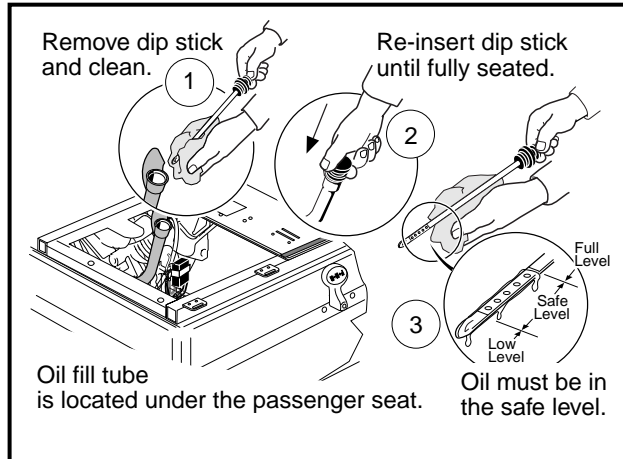

Figure 10-4 Checking Engine Oil

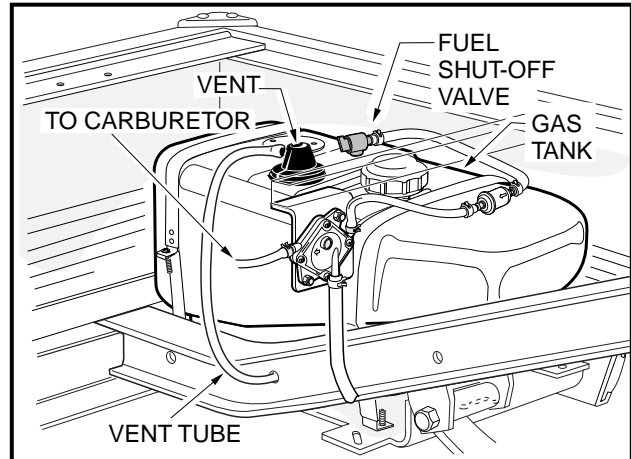

Figure 10-5 Gasoline Tank

OIL VISCOSITY

Choose the viscosity according to the temperature as indicated by the oil viscosity chart (Figure 10-6, Page 10-7). See following NOTE.

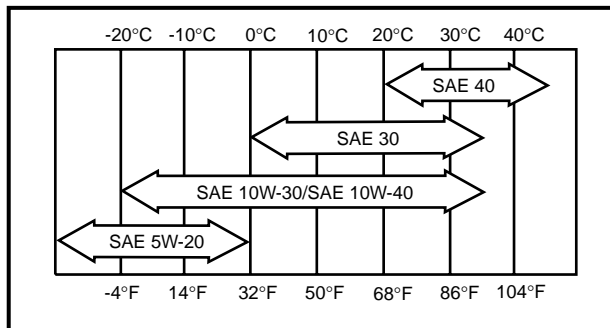

Figure 10-6 Oil Viscosity Chart

NOTE: Using multi-grade oils (5W-20, 10W-30, and 10W-40) will increase oil consumption. Check oil level more frequently when using multi-grade oils.

FUELING INSTRUCTIONS

Read **DANGER** and **WARNING** on pages 10-1 and 10-2.

▲ DANGER

- Turn key switch to the OFF position before fueling.
- Never pour gasoline into the fuel tank when the engine is hot or while it is running.
- To avoid electric arc caused by static electricity, the fuel storage/pumping device must be grounded. If the pump is not grounded, the vehicle must be grounded to the pump before and during the fueling operation.
- If the vehicle has an all-weather enclosure installed, the gas tank must be properly vented as shown (Figure 10-5, Page 10-7).
- To avoid the possibility of fire, clean up any spilled gasoline before operating the vehicle.

1. Remove the passenger seat.

Fueling Instructions, Continued:

2. Remove fuel cap and fill the fuel tank with fresh, unleaded gasoline only (**Figure 10-5, Page 10-7**). See following **CAUTION** and **NOTE**.

⚠ CAUTION

- *To allow for expansion, do not fill higher than one inch (2.54 cm) from the top of the fuel tank. Avoid spilling fuel.*

NOTE: Whenever possible, avoid using oxygenated fuels and fuels that are blended with alcohol. Vehicles to be stored for extended periods should be prepared for storage as instructed in Section 3 of this manual. **See Storage – Gasoline Vehicle, Section 3, Page 3-1.**

3. Replace fuel cap on tank. Make sure cap is tightened securely.
4. Replace passenger seat. **See following WARNING.**

⚠ WARNING

- **Make sure seat hinges and latch are securely engaged before operating vehicle.**

BATTERY

For periodic battery maintenance, see **Battery, Section 12, Page 12-31.**

SECTION 11 – TROUBLESHOOTING AND ELECTRICAL SYSTEM

⚠ DANGER

- **Battery – Explosive gases! Do not smoke. Keep sparks and flames away from the vehicle and service area. Ventilate when charging or using in an enclosed space. Wear a full face shield and rubber gloves when working on or near batteries.**
- **Battery – Poison! Contains acid! Causes severe burns. Avoid contact with skin, eyes or clothing. Antidotes:**
 - **External: Flush with water. Call a physician immediately.**
 - **Internal: Drink large quantities of water. Follow with milk of magnesia or vegetable oil. Call a physician immediately.**
 - **Eyes: Flush with water for 15 minutes. Call a physician immediately.**
- **Gasoline – Flammable! Explosive! Do not smoke. Keep sparks and flames away from vehicle and service area. Service only in a well-ventilated area.**
- **Do not operate vehicle in an enclosed area without proper ventilation. The engine produces carbon monoxide, which is an odorless, deadly poison.**

⚠ WARNING

- Only trained technicians should repair or service the vehicle. Anyone doing even simple repairs or service should have knowledge and experience in electrical and mechanical repair.
- Follow the procedures exactly as stated in this manual, and heed all DANGER, WARNING, and CAUTION statements in this manual as well as those affixed to the vehicle.
- Wear safety glasses or approved eye protection while servicing vehicle.
- Turn key switch OFF, place Forward/Reverse handle in the NEUTRAL position, and remove key before servicing the vehicle.
- Moving parts! Do not attempt to service the vehicle while it is running.
- Use insulated tools when working near batteries or electrical connections. Use extreme caution to avoid shorting of components or wiring.
- To avoid unintentionally starting the vehicle:
 - Disconnect battery cables, negative cable (–) first.
 - Disconnect the spark plug wire from the spark plug.
- Frame ground – Do not allow tools or other metal objects to contact frame when disconnecting battery cables or other electric wiring. Never allow a positive wire to touch the vehicle frame, engine, or any other metal component.
- Lift only one end of the vehicle at a time. Before lifting, set the park brake when lifting the front of the vehicle, unload the cargo bed, and chock the wheels that remain on the floor. Use a suitable lifting device (chain hoist or hydraulic floor jack) with 1000 lb. (454 kg) minimum lifting capacity. Do not use lifting device to hold vehicle in raised position. Use approved jack stands of proper weight capacity to support the vehicle.

GENERAL INFORMATION

This section contains the information required to correctly troubleshoot the vehicle. A troubleshooting guide is provided for general troubleshooting. For issues pertaining solely to the electrical system, proceed to Circuit Testing on page 11-14.

In addition to troubleshooting, this section contains general information on the electrical system and the electrical circuits of the system.

TROUBLESHOOTING GUIDE

The following troubleshooting guide will be helpful in identifying operating difficulties should they occur. The guide includes the symptom, probable cause(s) and suggested checks. The procedures used in making these checks can be found in the referenced sections of this maintenance and service manual.

SYMPTOM	POSSIBLE CAUSES	REFER TO
Engine does not start easily.	Spark plug is partially fouled or in poor condition	Section 13 – FE350 Engine
	Spark plug wire is damaged or loose	Section 13 – FE350 Engine
	Loose wire connection at ignition coil or RPM limiter	Section 11 – Troubleshooting and Electrical System Test Procedures 14, 15, and 16
	Intermittent ignition coil failure	Section 11 – Troubleshooting and Electrical System Test Procedures 14, 15, and 16
	Low cylinder compression	Section 13 – FE350 Engine
	Water or dirt in the fuel system and/or carburetor; dirty or clogged fuel filter	Section 14 – Fuel System
	Carburetor improperly adjusted	Section 14 – Fuel System
	Starter/generator belt is slipping	Section 12 – Electrical Components Belt Tension Adjustment on page 12-12
Engine starts but does not run smoothly.	Spark plug is fouled or in poor condition	Section 13 – FE350 Engine
	Spark plug wire is damaged or loose	Section 13 – FE350 Engine
	Intermittent ignition coil failure	Section 11 – Troubleshooting and Electrical System Test Procedures 14, 15, and 16
	Water or dirt in the fuel system and/or carburetor; dirty or clogged fuel filter	Section 14 – Fuel System
	Fuel pump malfunction; fuel pressure to carburetor too low	Section 14 – Fuel System
Engine turns but fails to start.	Fuel tank is empty	Section 14 – Fuel System
	Fuel line or filters clogged	Section 14 – Fuel System
	Fouled spark plug	Section 13 – FE350 Engine
	Spark plug wire damaged or loose	Section 13 – FE350 Engine
Troubleshooting Guide continued on next page...		

SYMPTOM	POSSIBLE CAUSES	REFER TO
Engine turns but fails to start, continued.	Loose wire connection at ignition coil or RPM limiter	Section 11 – Troubleshooting and Electrical System Test Procedures 14, 15, and 16
	Ignition coil or RPM limiter failed	Section 11 – Troubleshooting and Electrical System Test Procedures 14, 15, and 16
	Engine flooded with fuel as result of excess choking	Pioneer 1200 Owner's Manual, Controls and Indicators. See Choke.
	Kill circuit grounded	Section 11 – Troubleshooting and Electrical System Test Procedures 14, 15, and 16
	Fuel pump malfunction or failure	Section 14 – Fuel System
Engine overheats.	Fan screen is partially blocked or plugged	Section 13 – FE350 Engine
	Governor is improperly adjusted	Section 14 – Fuel System
	Carburetor is too lean; check main jet size	Section 14 – Fuel System
Engine pre-ignites.	Excessive carbon deposits on piston head or in combustion chamber	Section 13 – FE350 Engine
	Spark plug heat range is incorrect	Section 13 – FE350 Engine
	Unsuitable or contaminated fuel	Section 14 – Fuel System
Loss of engine power.	Exhaust valve is restricted with carbon deposit	Section 13 – FE350 Engine
	Muffler or exhaust pipe restricted with carbon or other substance	Section 15 – Exhaust System
	Ignition coil failed	Section 11 – Troubleshooting and Electrical System Test Procedures 14, 15, and 16
	Air filter is dirty or clogged	Section 14 – Fuel System
	Governor is improperly adjusted	Section 14 – Fuel System
	Throttle linkage out of adjustment	Section 14 – Fuel System
	Low cylinder compression	Section 13 – FE350 Engine
	Spark plug failed	Section 13 – FE350 Engine
	Restricted fuel flow	Section 14 – Fuel System
	Torque converter is not backshifting properly	Section 17 – Torque Converter
Spark plug fouls repeatedly.	Incorrect plug	Section 13 – FE350 Engine
	Spark plug wire is damaged	Section 13 – FE350 Engine
	Unsuitable fuel, or incorrect (rich) fuel mixture	Section 14 – Fuel System
	Ignition coil failed	Section 11 – Troubleshooting and Electrical System Test Procedures 14, 15, and 16
Troubleshooting Guide continued on next page...		

SYMPTOM	POSSIBLE CAUSES	REFER TO
Spark plug fouls repeatedly, continued	Rings are heavily worn, low cylinder pressure	Section 13 – FE350 Engine
Carburetor floods.	Inlet valve or seat is leaking, dirty, worn, or damaged	Section 14 – Fuel System
	Float is damaged and filled with gasoline	Section 14 – Fuel System
	Float needle valve not functioning properly	Section 14 – Fuel System
	Carburetor vent is clogged	Section 14 – Fuel System
Starter fails to operate.	Lockout cam is in the wrong position	Section 11 – Troubleshooting and Electrical System Lockout Cam Circuit on page 11-12
	Fuse is blown	Section 11 – Troubleshooting and Electrical System Test Procedure 2
	Battery is dead	Section 11 – Troubleshooting and Electrical System Test Procedure 1
	Starter control circuit is not operating	Section 11 – Troubleshooting and Electrical System Starter Circuit on page 11-15
	Starter/generator failed	Section 11 – Troubleshooting and Electrical System Test Procedure 8
	Starter solenoid failed	Section 11 – Troubleshooting and Electrical System Test Procedure 6
	Key switch failed	Section 11 – Troubleshooting and Electrical System Test Procedure 4
	Lockout cam limit switch failed	Section 11 – Troubleshooting and Electrical System Test Procedure 7
	Loose or broken wire in starter/generator circuit	Section 12 – Electrical Components Starter/Generator on page 12-2
	Cylinder and/or crankcase flooded with fuel	Section 14 – Fuel System
Starter/Generator does not charge battery.	Diode failed (open condition)	Section 11 – Troubleshooting and Electrical System Test Procedure 10
	Loose or broken wire in the starter/generator circuit	Section 11 – Troubleshooting and Electrical System Test Procedure 11
	Generator field coil is shorted	Section 11 – Troubleshooting and Electrical System Test Procedure 11
	Brushes are worn or commutator is dirty	Section 12 – Electrical Components Starter/Generator on page 12-2
Troubleshooting Guide continued on next page...		

SYMPTOM	POSSIBLE CAUSES	REFER TO
Starter/Generator does not charge battery, continued.	Starter/generator belt is loose or slipping	Section 12 – Electrical Components Belt Tension Adjustment on page 12-12
	Voltage regulator failed	Section 11 – Troubleshooting and Electrical System Test Procedure 12
	Battery failed	Section 11 – Troubleshooting and Electrical System Test Procedure 1
Transmission does not engage or disengage smoothly.	Transmission shifter linkage is binding or is out of adjustment	Section 16 – Unitized Transaxle with Differential Lock
	Idle RPM setting is set too high	Section 14 – Fuel System
	Insufficient (low) level of lubricant or wrong type of lubricant in transmission	Section 16 – Unitized Transaxle with Differential Lock
	Internal gears are damaged or worn	Section 16 – Unitized Transaxle with Differential Lock
	Synchronizer rings are worn, damaged or jammed	Section 16 – Unitized Transaxle with Differential Lock
Excessive vehicle vibration.	Engine mounting nuts or bolts are loose	Section 13 – FE350 Engine
	Snubber on frame is worn or damaged	Section 13 – FE350 Engine
	Misaligned muffler mounting clamp	Section 15 – Exhaust System
	Damaged drive belt or starter belt	Section 17 – Torque Converter
	Damaged drive clutch	Section 17 – Torque Converter
	Damaged driven clutch	Section 17 – Torque Converter
	Damaged starter/generator pulley	Section 12 – Electrical Components Starter/Generator on page 12-2
	RPM setting is incorrect	Section 14 – Fuel System Engine RPM Adjustment on page 14-13
Torque converter does not shift smoothly.	Drive belt is worn, cracked, glazed, or frayed	Section 17 – Torque Converter
	Drive clutch malfunction	Section 17 – Torque Converter
	Driven clutch malfunction	Section 17 – Torque Converter
	Governor is sticking	Section 16 – Unitized Transaxle with Differential Lock
Engine won't stop running.	Kill circuit wire is disconnected from the ignition coil	Section 11 – Troubleshooting and Electrical System Test Procedure 13
	Key switch failure	Section 11 – Troubleshooting and Electrical System Test Procedures 4 and 17
	Carburetor is too lean; check main and pilot jet sizes	Section 14 – Fuel System
	Carburetor throttle stop screw out of adjustment	Section 14 – Fuel System

WIRING DIAGRAM

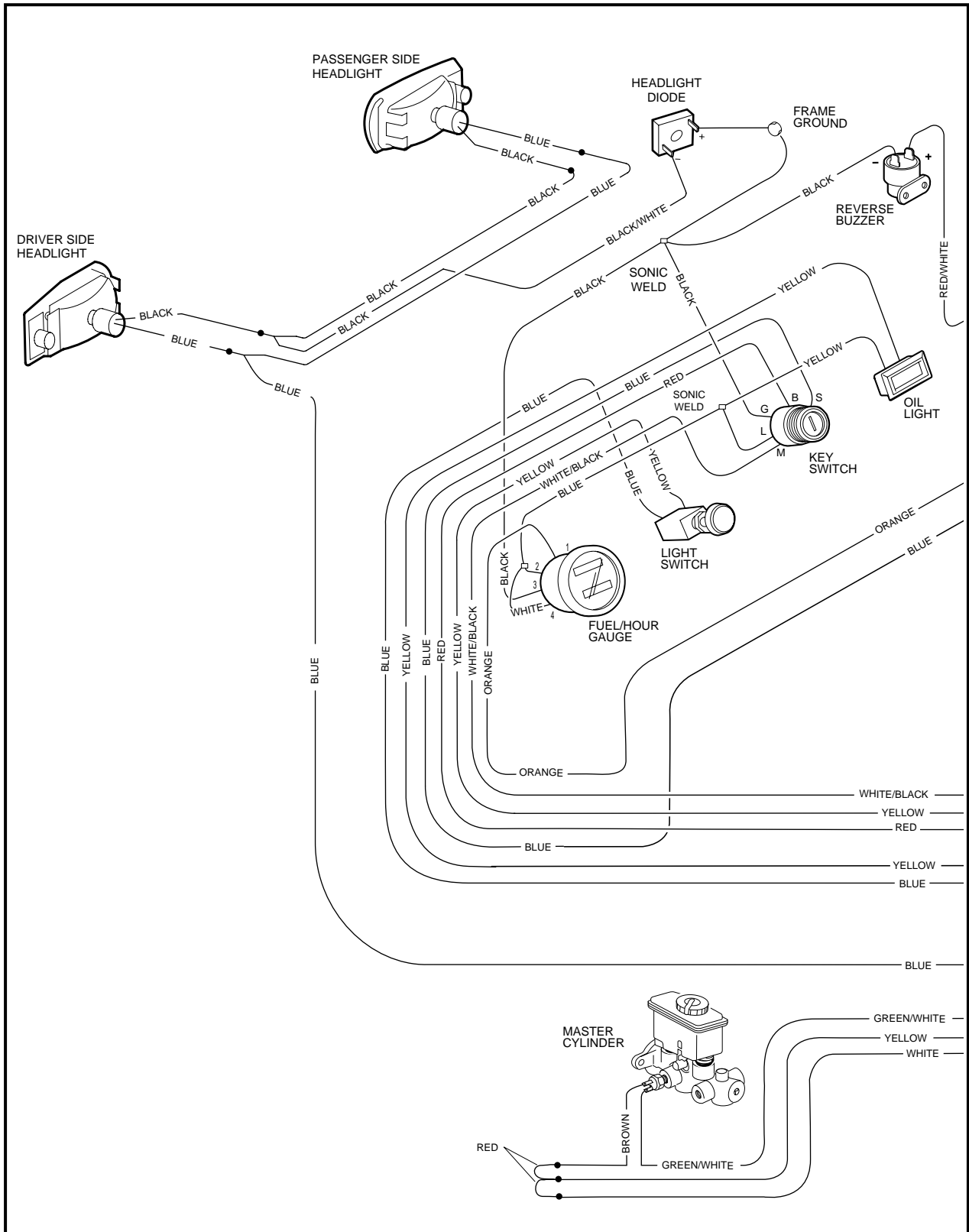
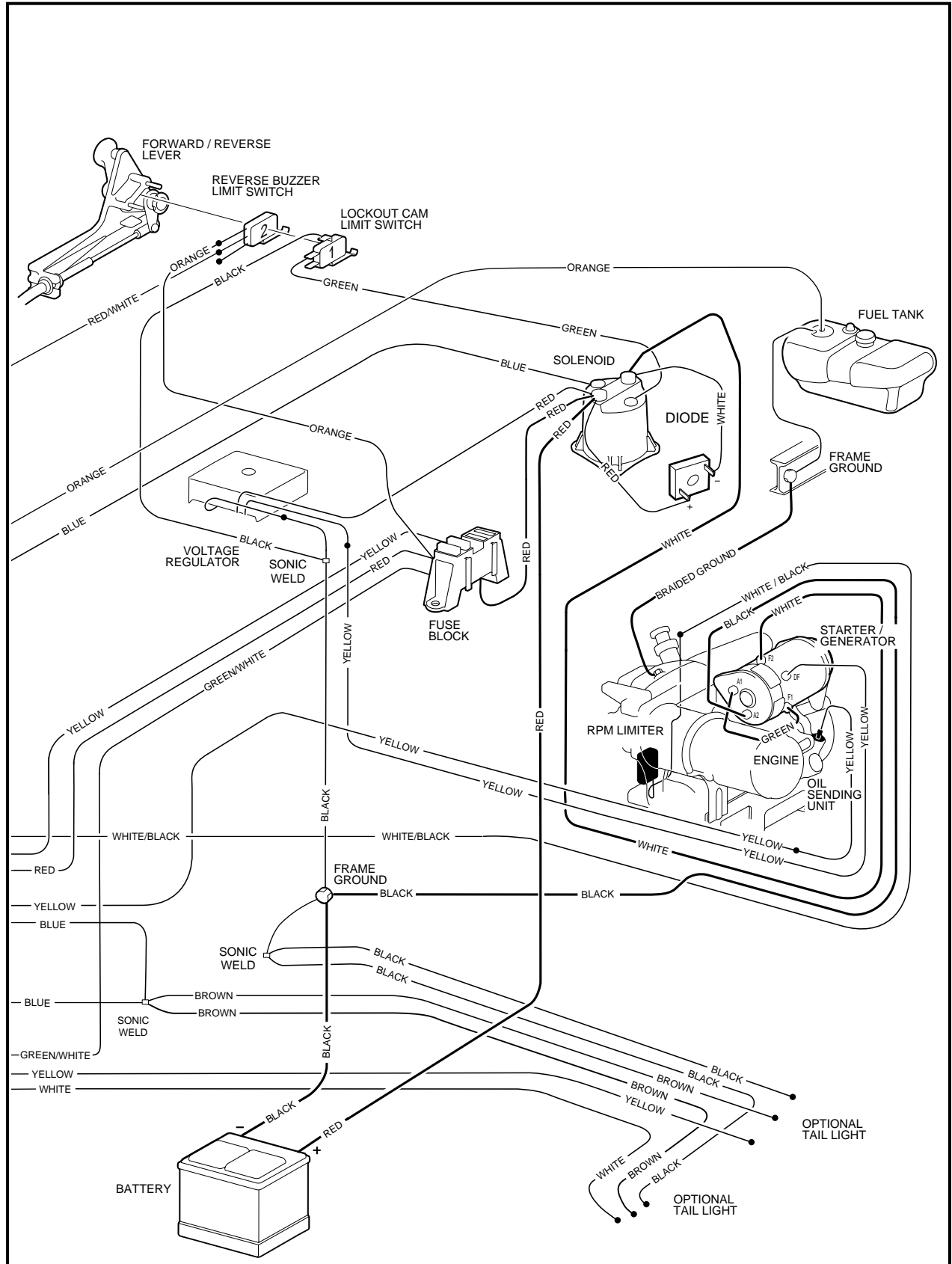

Figure 11-1 Wiring Diagram for Pioneer 1200 (Front)



Wiring Diagram for Pioneer 1200 (Rear)

ELECTRICAL SYSTEM

The electrical system on the gasoline vehicle is 12 volts DC with negative ground to frame, and consists of ten circuits that are easily identified:

- Starter Circuit
- Generator Circuit
- Engine Ignition Circuit
- Engine Kill Circuit
- Reverse Buzzer Circuit
- Low Oil Warning Circuit
- Lockout Cam Circuit
- Fuel Gauge and Sending Unit Circuit
- Hour Gauge Circuit
- Lighting Circuit

Recognizing and understanding the function of each of these circuits will help to quickly isolate the source of an electrical problem. Use the troubleshooting flow charts in the Circuit Testing section to find the proper test procedure to correct the electrical problem. **See Circuit Testing on page 11-14.**

For a complete wiring diagram, see page 11-6.

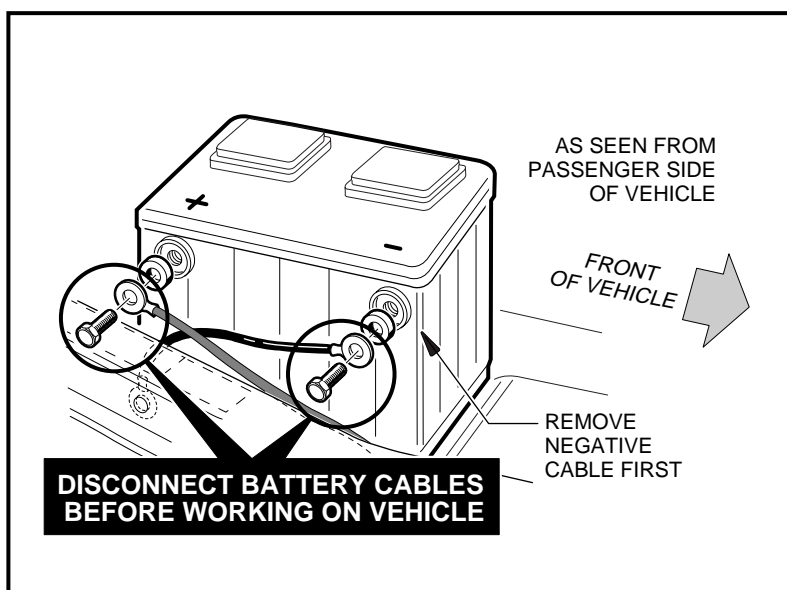

Figure 11-2 Battery Disconnect

ELECTRICAL CIRCUITS

STARTER CIRCUIT

The starter circuit consists of a 12-volt battery, fuse, key switch, lockout cam limit switch, solenoid, starter/generator, and connecting wires (**Figure 11-3, Page 11-9**). The battery is the source of power for the system. The fuse provides protection to the solenoid activating circuit. **See following NOTE.**

NOTE: The starter circuit is completely independent of the ignition circuit. The battery does not supply power for ignition. The battery supplies power to the starter/generator which in turn starts the engine components rotating. Once the engine is running, the ignition circuit supplies power to the spark plug. **See Engine Ignition Circuit on page 11-10.**

The starter circuit is activated when the key switch is turned to the START position. Electrical current is then supplied to the solenoid coil, completing the circuit between the positive post of the battery and the F2 post of the starter/generator. The starter/generator then turns and cranks the engine through belt-driven pulleys.

NOTE: Engine rotation (clockwise) is as viewed from the clutch side of the engine.

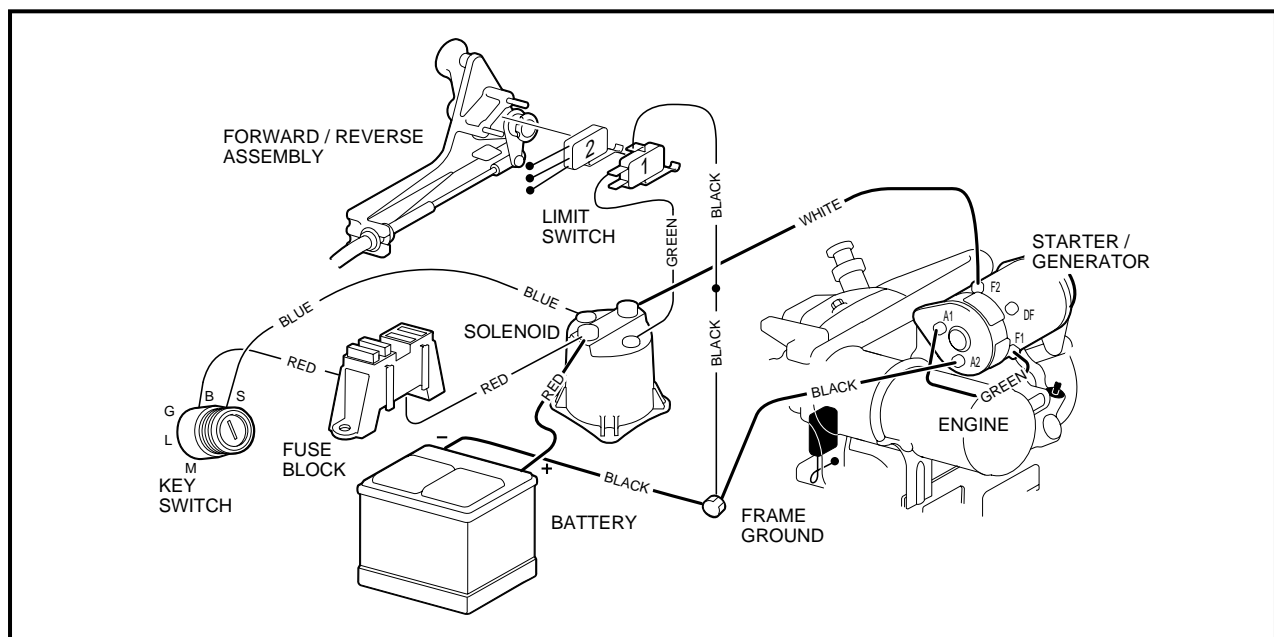

Figure 11-3 Starter Circuit – Pioneer 1200 Vehicle

GENERATOR CIRCUIT

The generator circuit consists of the starter/generator, voltage regulator, diode, solenoid, battery, and connecting wires (**Figure 11-4, Page 11-10**).

When battery power is first supplied to the starter/generator, the starter/generator turns the engine at low RPM (approx. 700). Once the engine starts running, it then drives the starter/generator. At any engine RPM over 1215 (3000 starter/generator RPM), the starter/generator functions as a generator, supplying charging current, through the diode, to the battery. To prevent battery overcharging, the voltage regulator senses battery voltage, and by opening and closing an electronic switch, controls the amount of charge going to the battery.

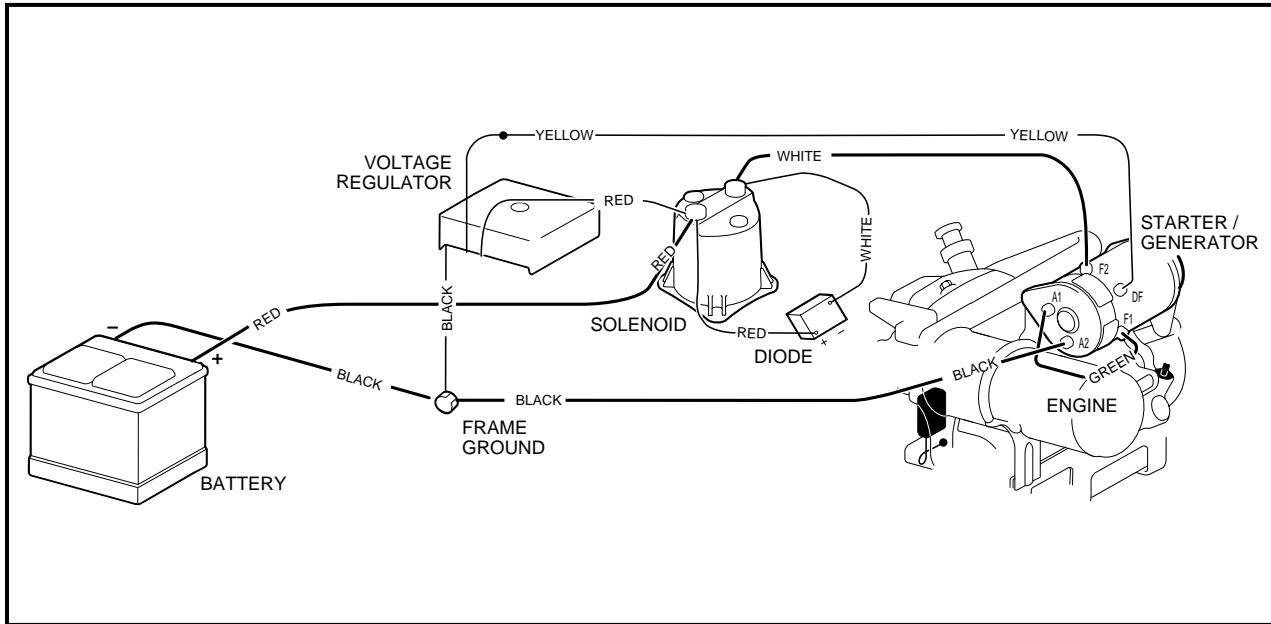

Figure 11-4 Generator Circuit

ENGINE IGNITION CIRCUIT

The engine ignition circuit is independent of all other circuits except the kill circuit. It consists of the ignition coil with internal igniter, spark plug, RPM limiter, and connecting wires (**Figure 11-5, Page 11-10**).

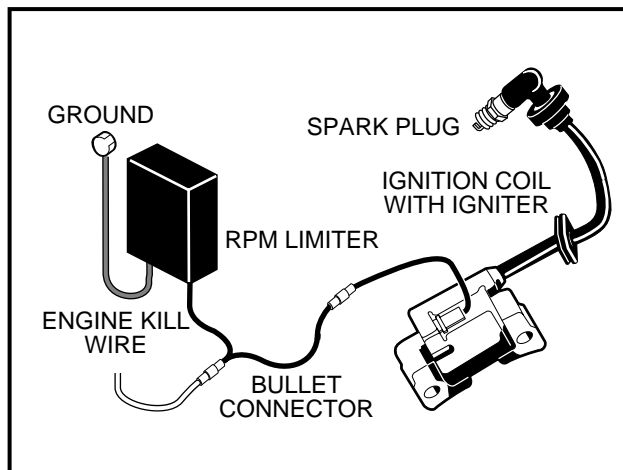

Figure 11-5 Ignition Circuit

ENGINE KILL CIRCUIT

The ignition coil supplies electrical power for the spark plug; therefore, the proper way to stop the engine is to run this electrical power to ground, bypassing the spark plug (**Figure 11-6, Page 11-11**).

The engine kill circuit consists of the key switch and connecting wires. The engine can be stopped by turning the key switch to the OFF position. **See Lockout Cam Circuit on page 11-12.**

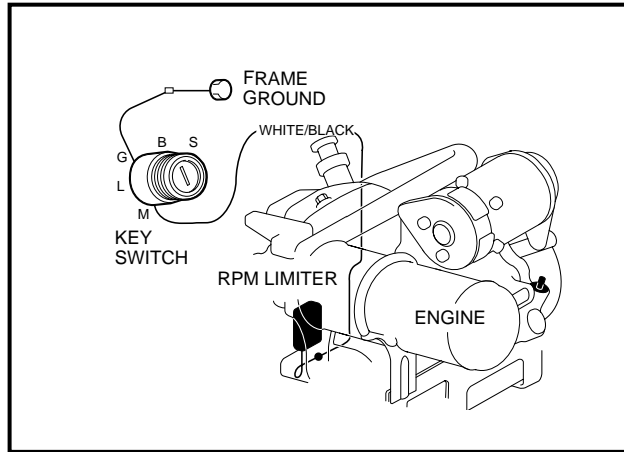

Figure 11-6 Engine Kill Circuit

REVERSE BUZZER CIRCUIT

The reverse buzzer is a safety warning device that sounds when the Forward/Reverse handle is in REVERSE. It functions to remind the operator not to leave the vehicle in reverse and to warn anyone in the area that the vehicle is in reverse.

The reverse buzzer circuit consists of a reverse buzzer, reverse buzzer limit switch, fuse, fuse block, and connecting wires (**Figure 11-7, Page 11-11**).

The battery supplies power through the fuse block and is controlled by the reverse buzzer limit switch which is activated by a cam located on the back of the Forward/Reverse shifter. When the Forward/Reverse handle is placed in REVERSE, a cam depresses the reverse limit switch, closing the circuit. The reverse buzzer sounds.

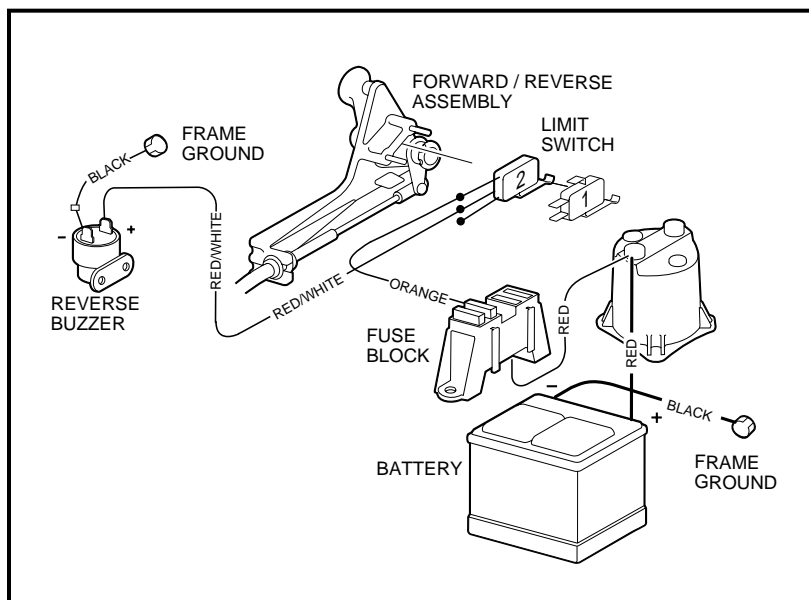

Figure 11-7 Reverse Buzzer Circuit for Pioneer 1200

LOW OIL WARNING CIRCUIT

The low oil warning circuit consists of an oil level sensor in the engine, a dash-mounted low oil warning light, key switch, and connecting wires (**Figure 11-8, Page 11-12**).

The light receives power through the key switch when the key switch is turned to the ON position. When the oil level in the crankcase is low, the oil level sensor closes the circuit to ground and illuminates the low oil warning light.

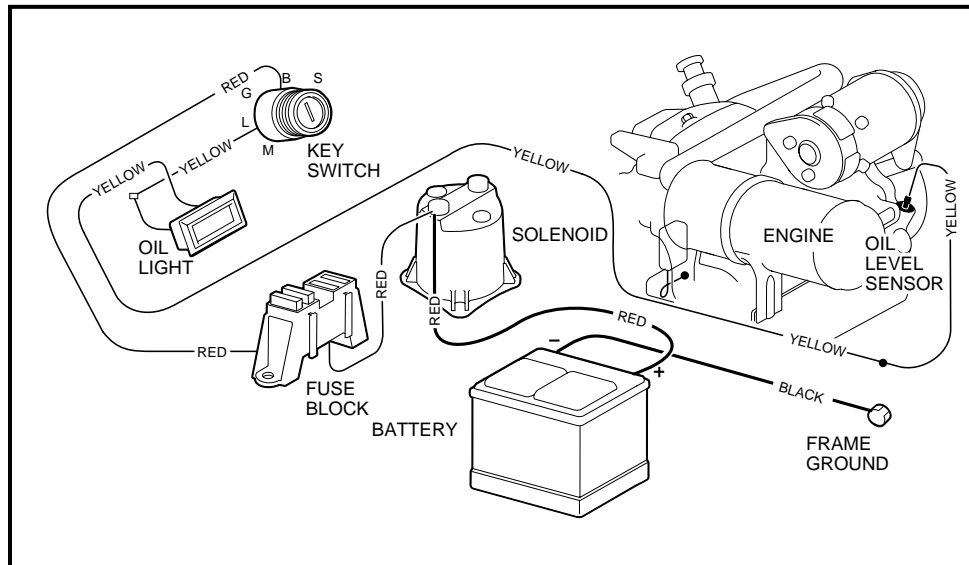

Figure 11-8 Low Oil Warning Circuit

LOCKOUT CAM CIRCUIT

The Pioneer 1200 is equipped with a lockout cam that allows the engine to be started only when the Forward/Reverse handle is in the NEUTRAL position. The lockout cam (yellow) is located on the back of the Forward/Reverse handle, inside the engine compartment.

NOTE: Be sure the cam is in the correct position. The cam should activate the limit switch only when the Forward/Reverse handle is in the NEUTRAL position (**Figure 11-9, Page 11-12**).

The lockout cam circuit consists of the connecting wires, and a limit switch that is located on the Forward/Reverse shifter assembly and is activated by the lockout cam (**Figure 11-10, Page 11-13**).

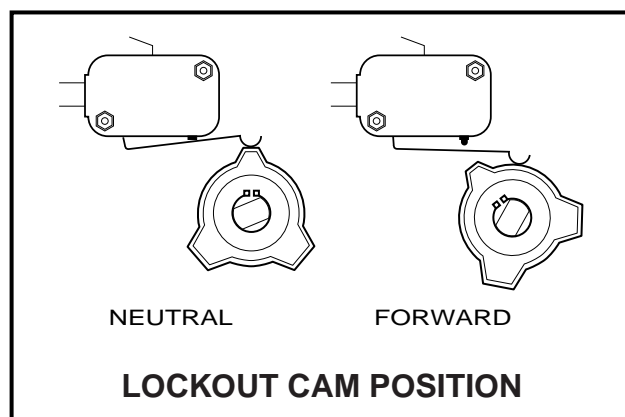

Figure 11-9 Correct Position for Lockout Cam

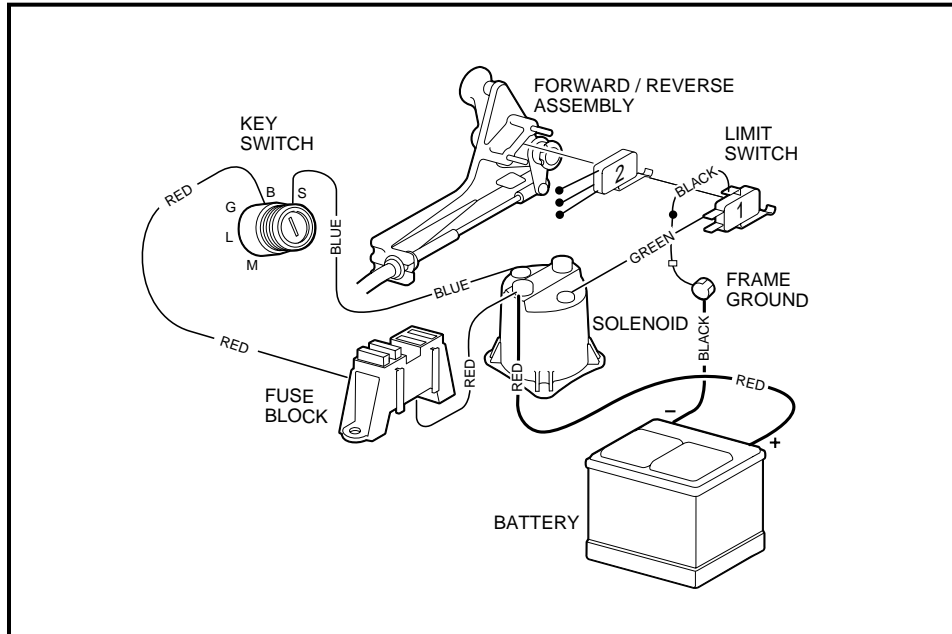

Figure 11-10 Lockout Cam Circuit

FUEL GAUGE AND SENDING UNIT CIRCUIT

The fuel gauge and sending unit circuit consists of the fuel/hour gauge, fuel level sending unit, key switch and connecting wires. The fuel gauge/sending unit picks up power from the key switch when the key switch is turned to the ON position. The power goes through the gauge to the sending unit at the fuel tank. The sending unit tells the gauge how much fuel is in the tank (**Figure 11-11, Page 11-13**).

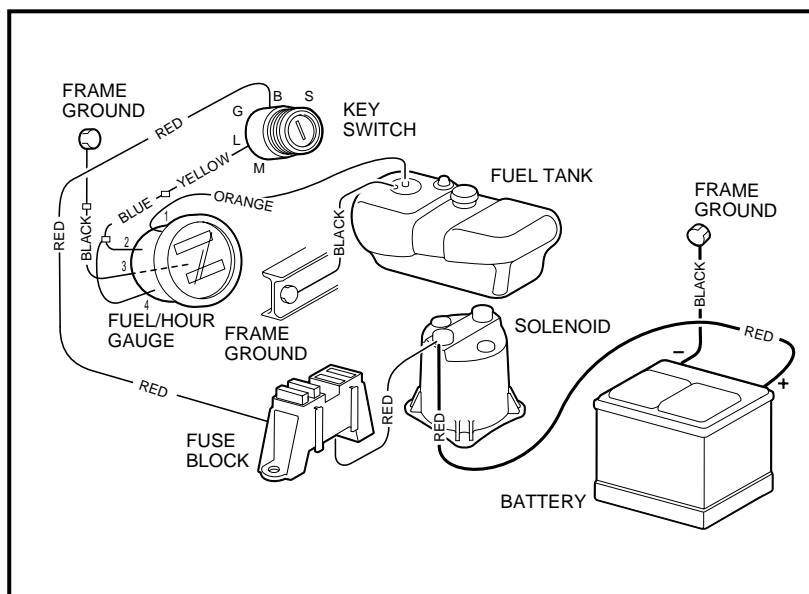

Figure 11-11 Fuel Gauge and Sending Unit Circuit

HOUR GAUGE CIRCUIT

The hour gauge circuit consists of the fuel/hour gauge, key switch, solenoid, and connecting wires (**Figure 11-12, Page 11-14**).

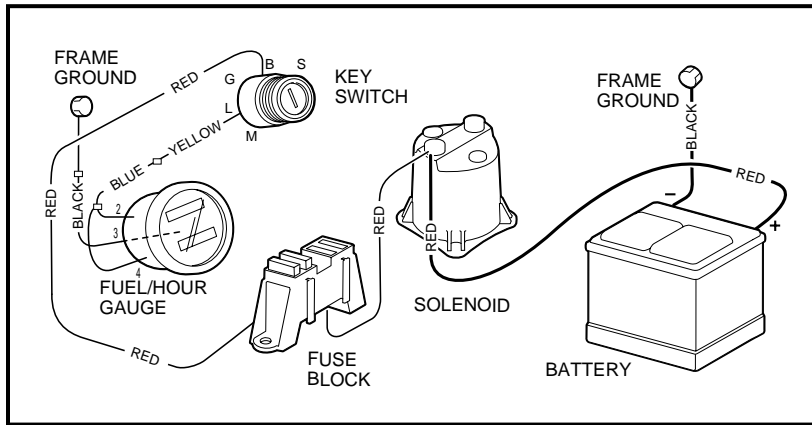

Figure 11-12 Hour Gauge Circuit

LIGHTING CIRCUIT

The headlights receive power through the fuse block when the light switch is pulled to the ON position (**Figure 11-13, Page 11-14**).

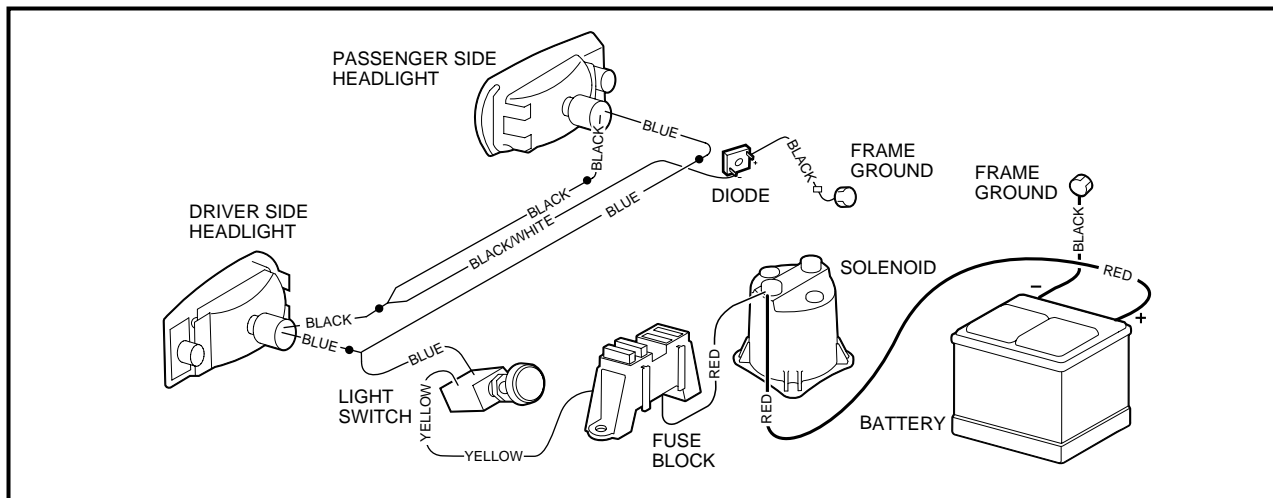

Figure 11-13 Pioneer 1200 Lighting Circuit

CIRCUIT TESTING

Read DANGER and WARNING on page 11-1.

Before testing the electrical circuits to determine the source of an electrical problem, test the vehicle battery to determine whether or not it is the source of the problem. A hydrometer, multimeter, and 160 ampere load tester will be required. **See Test Procedure 1 – Battery on page 11-21.**

TESTING THE STARTER CIRCUIT AND GENERATOR CIRCUIT

Read **DANGER** and **WARNING** on page 11-1.

Use the following charts (**Figure 11-14, Page 11-15** and **Figure 11-15, Page 11-15**) to begin troubleshooting problems with the starter and generator circuits.

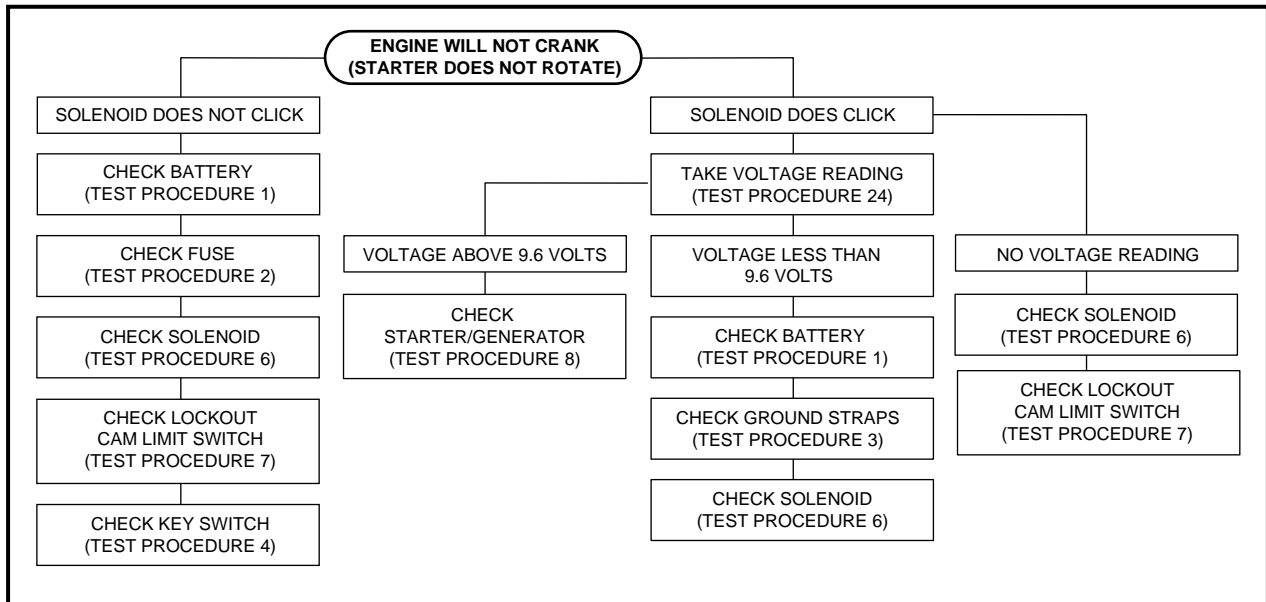

Figure 11-14 Testing the Starter Circuit

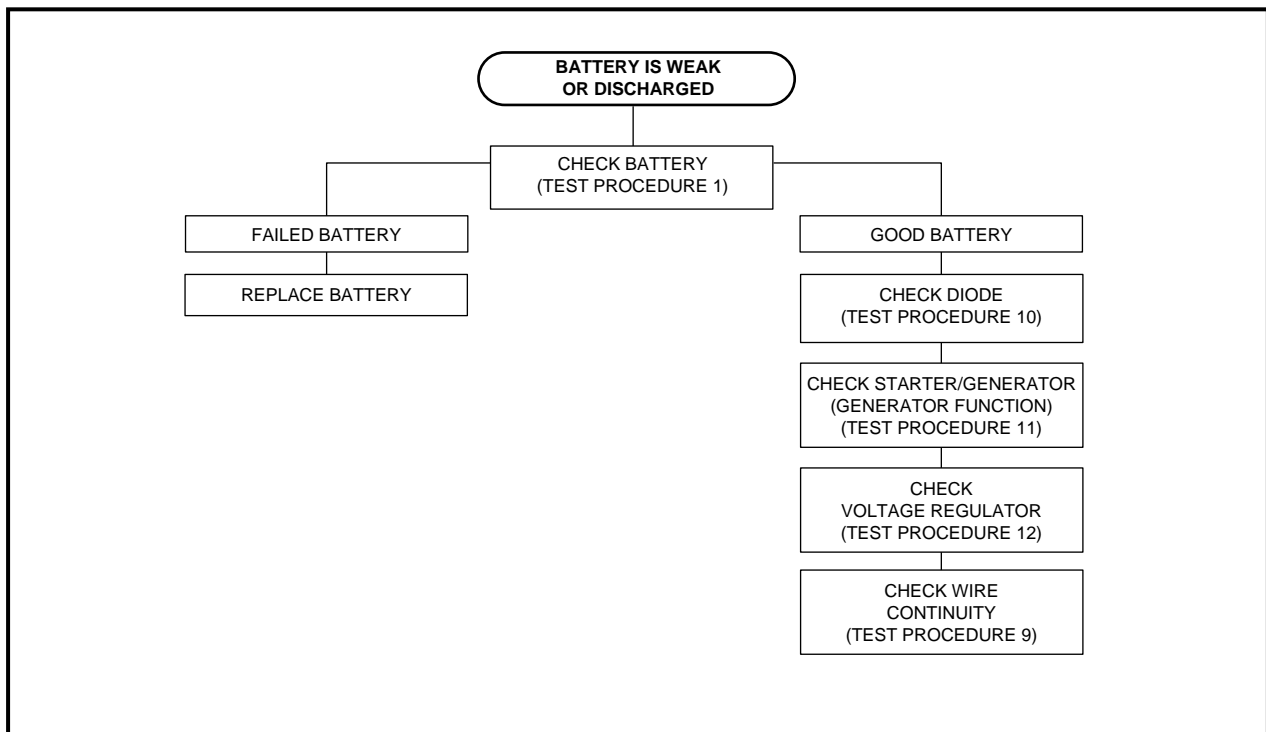

Figure 11-15 Testing the Generator Circuit

TESTING THE ENGINE IGNITION CIRCUIT

Read **DANGER** and **WARNING** on page 11-1.

Use the chart (Figure 11-16) to begin troubleshooting problems with the engine ignition circuit.

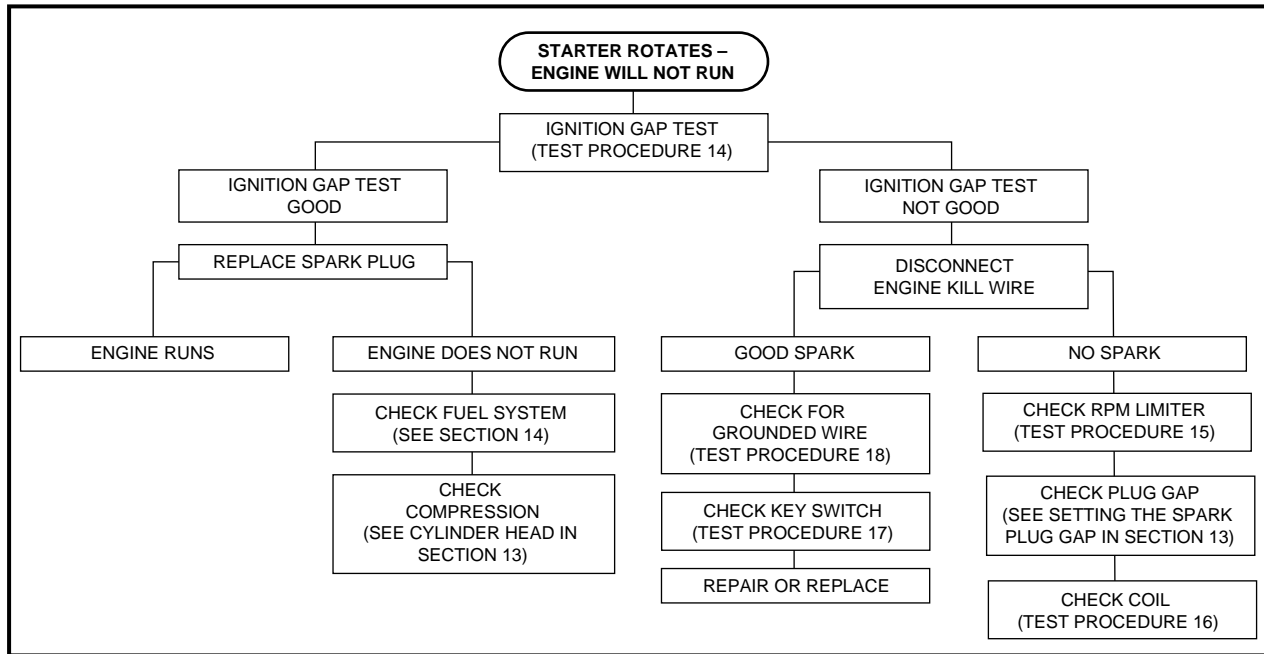

Figure 11-16 Testing the Engine Ignition Circuit

TESTING THE ENGINE KILL CIRCUIT

Read **DANGER** and **WARNING** on page 11-1.

Use the chart (Figure 11-17) to begin troubleshooting problems with the engine kill circuit.

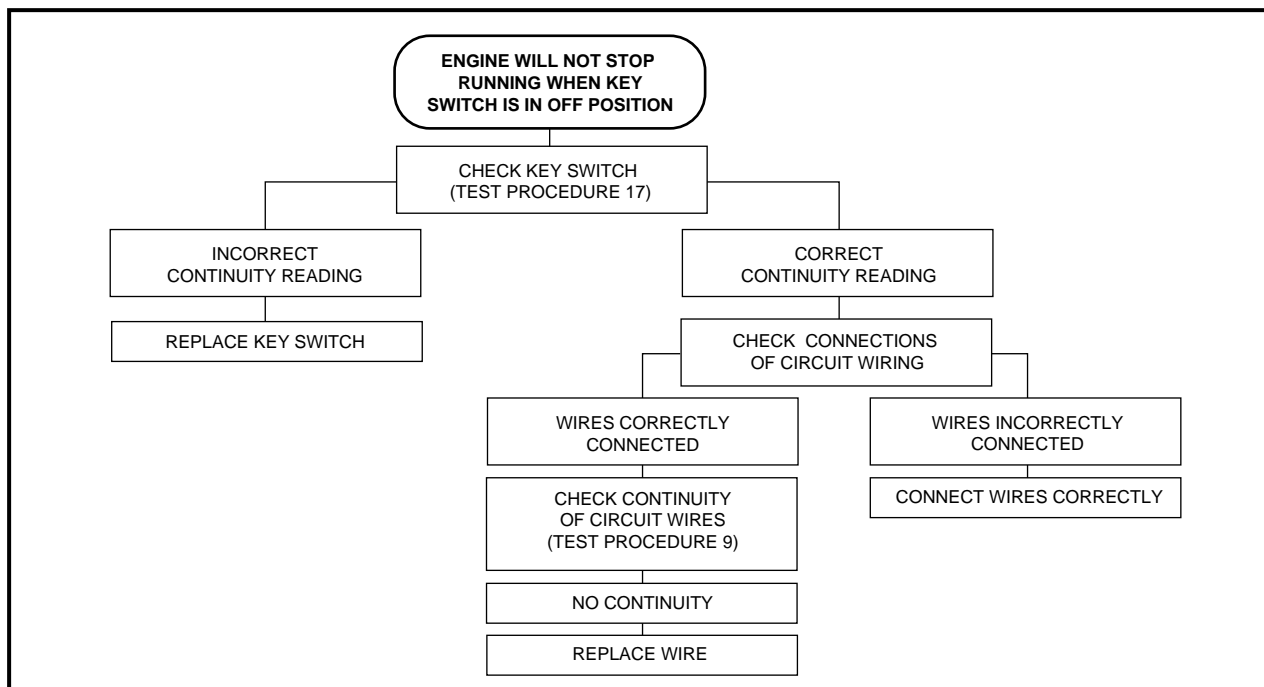

Figure 11-17 Testing the Engine Kill Circuit

TESTING THE REVERSE BUZZER CIRCUIT

Read **DANGER** and **WARNING** on page 11-1.

Use the following chart (**Figure 11-18**) to begin troubleshooting the reverse buzzer circuit.

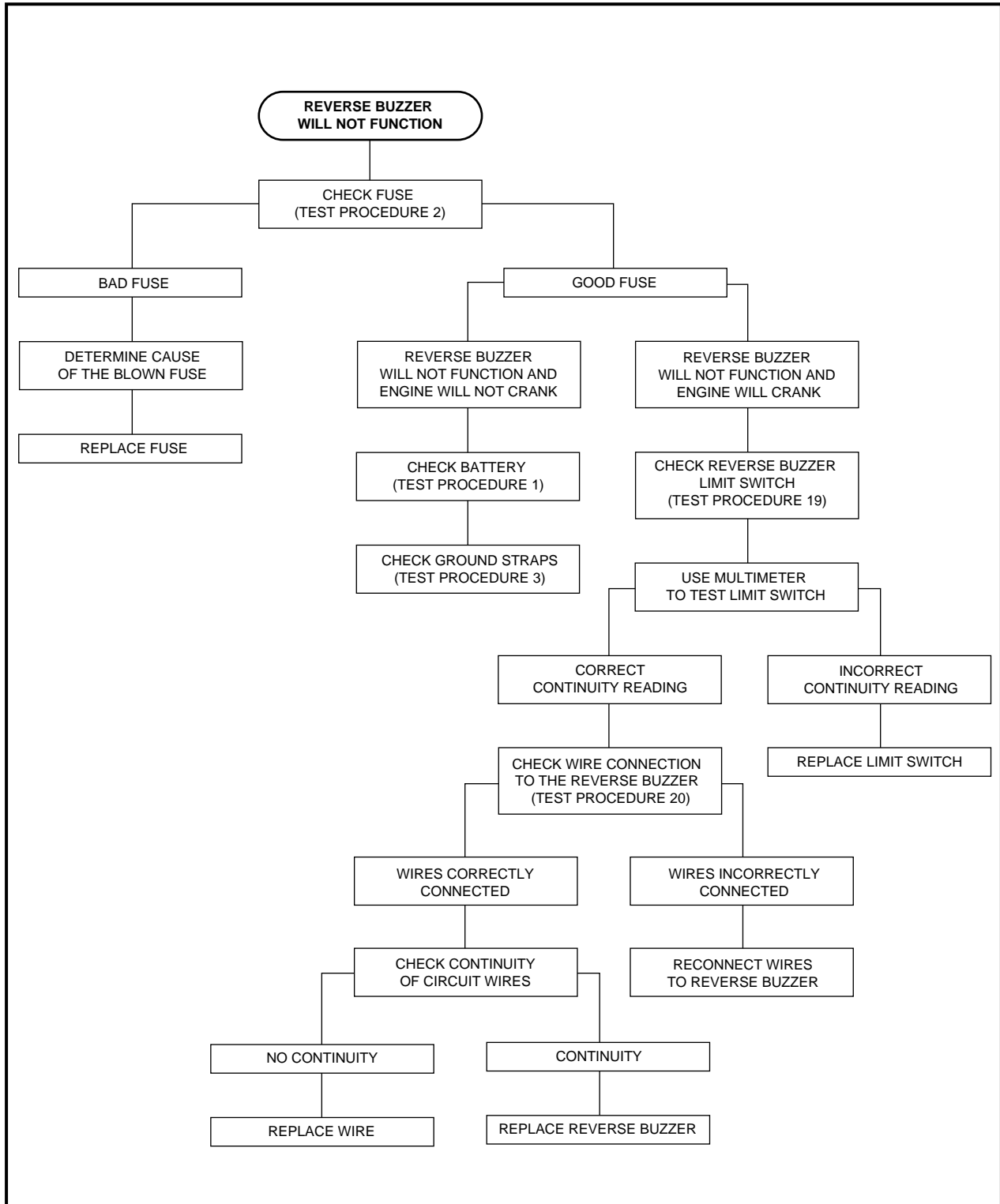

Figure 11-18 Testing the Reverse Buzzer Circuit

TESTING THE LOW OIL WARNING CIRCUIT

Read **DANGER** and **WARNING** on page 11-1.

Use the following chart (**Figure 11-19**) to begin troubleshooting the low oil warning circuit.

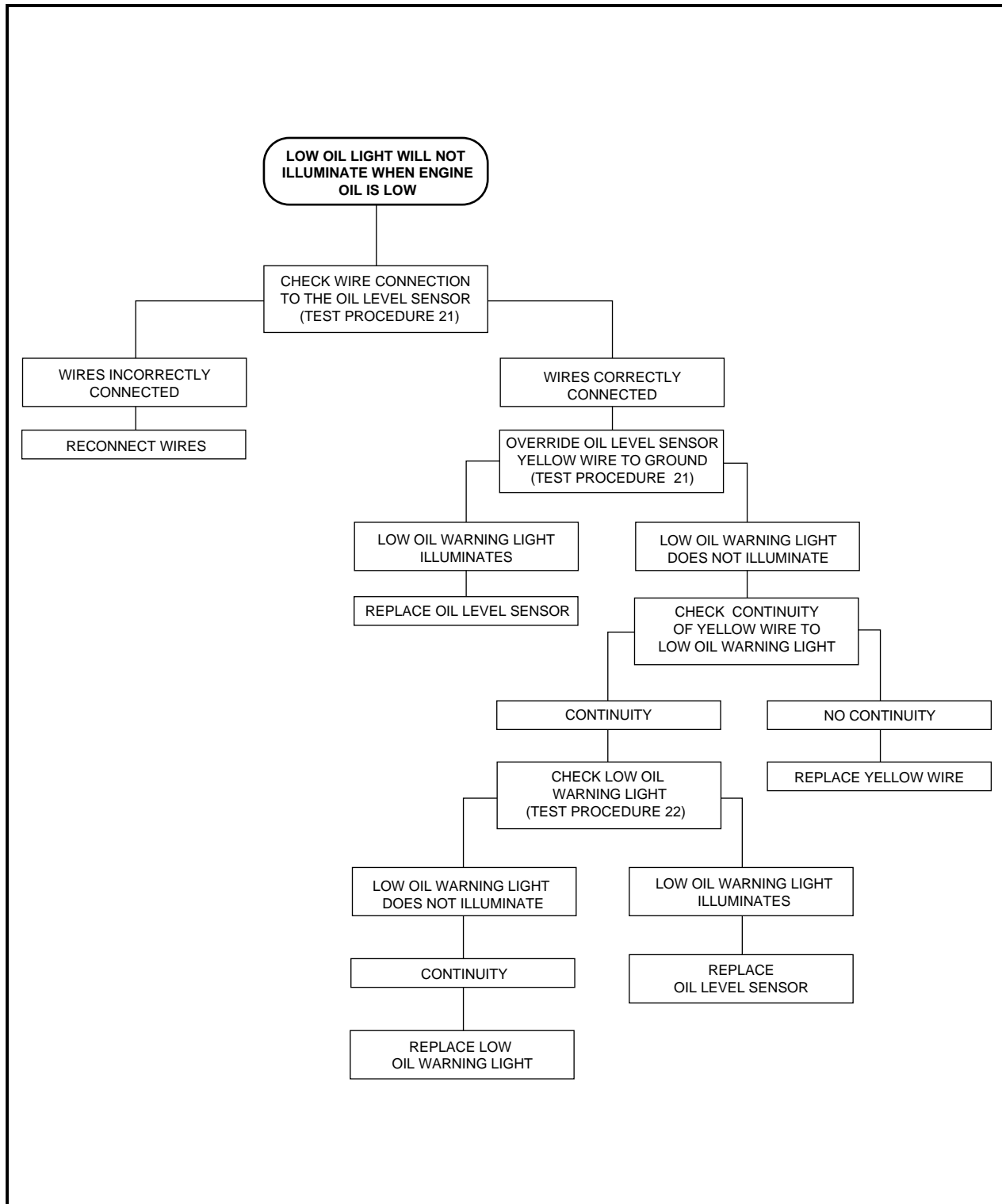

Figure 11-19 Testing the Low Oil Warning Circuit

TESTING THE LOCKOUT CAM CIRCUIT

Read **DANGER** and **WARNING** on page 11-1.

A failure in the lockout cam circuit will prevent the starter from rotating. See **Testing the Starter Circuit and Generator Circuit** on page 11-15.

TESTING THE FUEL GAUGE AND SENDING UNIT CIRCUIT

Read **DANGER** and **WARNING** on page 11-1.

Use the following chart (**Figure 11-20**) to begin troubleshooting the fuel gauge and sending unit circuit.

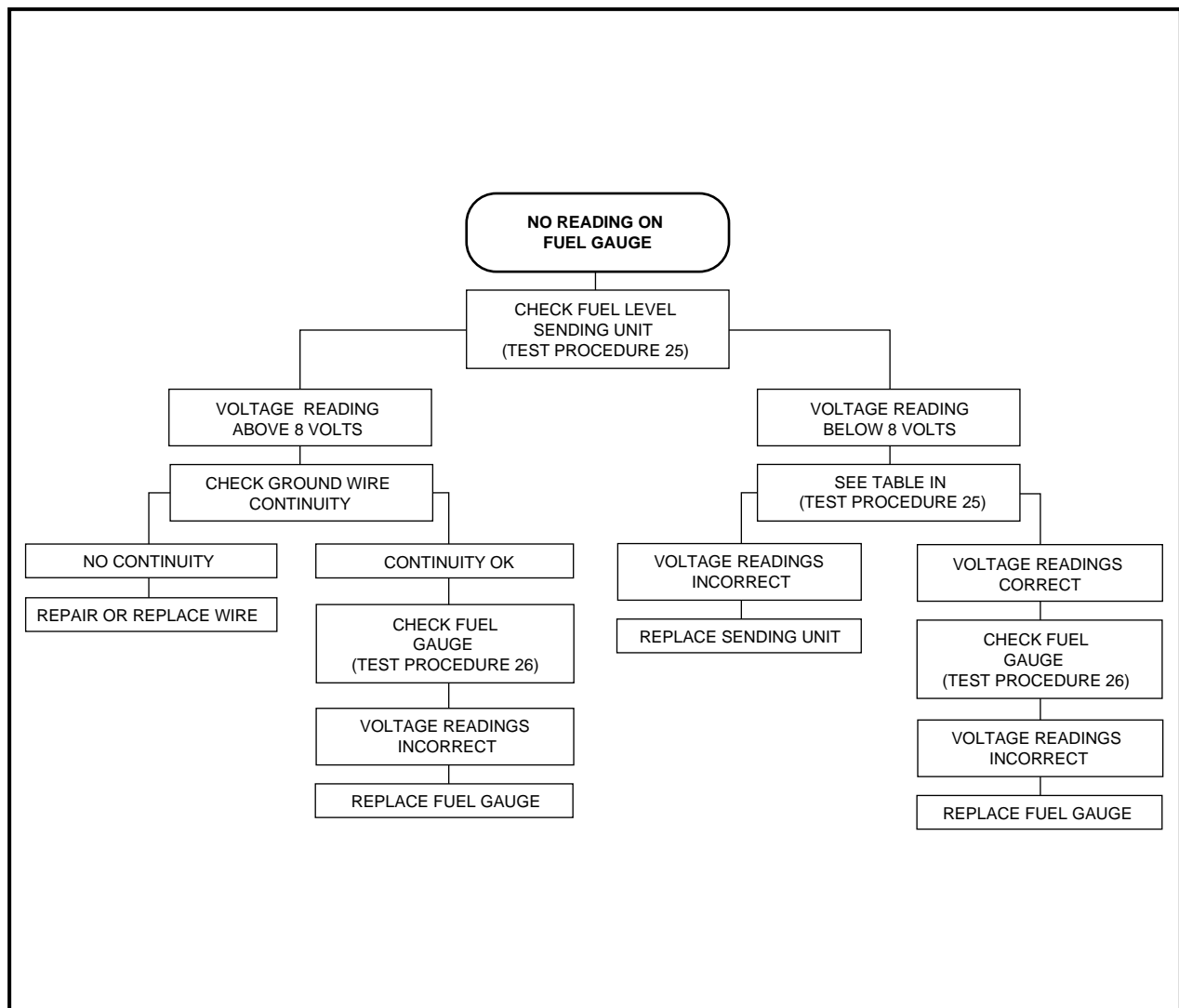

Figure 11-20 Testing the Fuel Gauge and Sending Unit Circuit

TESTING THE LIGHTING CIRCUIT

Read **DANGER** and **WARNING** on page 11-1.

Use the chart below and (Figure 11-21, Page 11-20) to begin troubleshooting the lighting circuit.

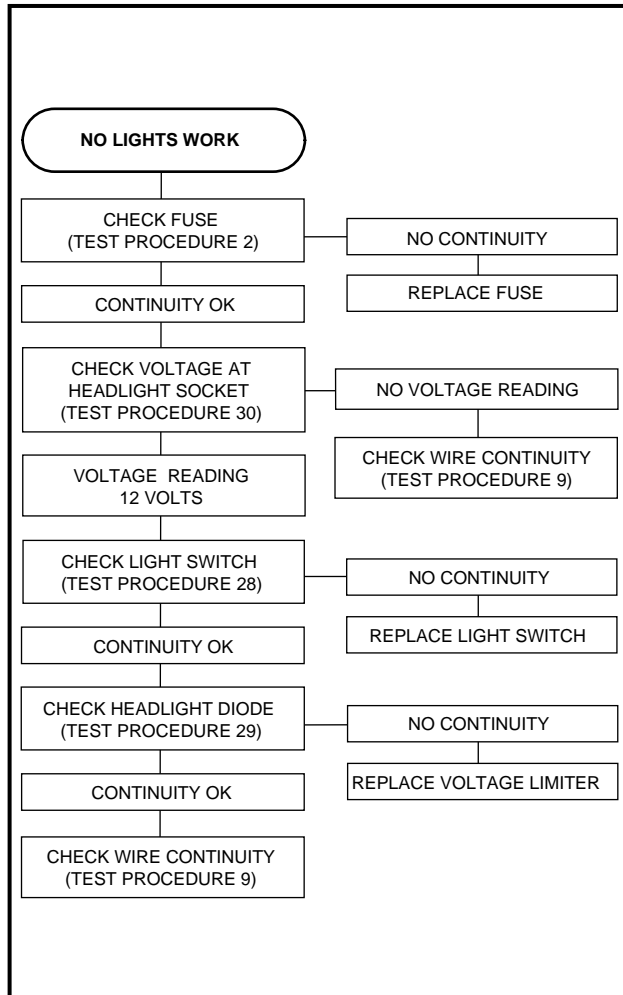

Figure 11-21 Testing the Lighting Circuit

TEST PROCEDURES

INDEX OF TEST PROCEDURES

1. Battery
2. Fuse
3. Ground Straps
4. Key Switch (Starter Circuit)
5. Key Switch (Accessory Terminal)
6. Solenoid
7. Lockout Cam Limit Switch
8. Starter/Generator (Starter Function)

9. Wire Continuity
10. Diode (Generator Circuit)
11. Starter/Generator (Generator Function)
12. Voltage Regulator
13. Disconnected Kill Wire
14. Ignition Spark
15. RPM Limiter
16. Ignition Coil
17. Key Switch (Engine Kill Circuit)
18. Engine Kill Wire
19. Reverse Buzzer Limit Switch
20. Reverse Buzzer
21. Oil Level Sensor
22. Oil Warning Light
23. Lockout Cam
24. Battery Test (Under Load)
25. Fuel Level Sending Unit
26. Fuel Gauge
27. Hour Gauge
28. Light Switch
29. Headlight Diode
30. Voltage at Headlight Socket

TEST PROCEDURE 1 – BATTERY

Read **DANGER** and **WARNING** on page 11-1.

DANGER

- ***Due to the danger of an exploding battery, wear a full face shield and rubber gloves when working around a battery.***
- ***Battery – Explosive gases! Do not smoke. Keep sparks and flames away from the vehicle and service area. Ventilate when charging or using in an enclosed space. Wear a full face shield and rubber gloves when working on or near batteries. For added protection, cover top of the battery when servicing the vehicle.***
- ***Battery – Poison! Contains acid! Causes severe burns! Avoid contact with skin, eyes, or clothing.***
 - ***External: Flush with water. Call a physician immediately.***
 - ***Internal: Drink large quantities of milk or water. Follow with milk of magnesia or vegetable oil. Call a physician immediately.***
 - ***Eyes: Flush with water for 15 minutes. Call a physician immediately.***

Test Procedure 1 – Battery, continued:

1. Place the Forward/Reverse handle in the NEUTRAL position, and chock the wheels.
2. Check for loose or corroded battery terminal connections. Clean, tighten, and replace connections as necessary.

Hydrometer Test

A hydrometer (CCI 1011478) measures the specific gravity. The higher the specific gravity, the higher the state of charge of the battery. A fully charged battery should read between 1.250 and 1.280 at 80 °F (27 °C). Never add acid to the battery to obtain a higher specific gravity (**Figure 11-22, Page 11-22**).

⚠ CAUTION

- Do not allow battery acid from battery caps or hydrometer to drip onto the body. Battery acid will cause permanent damage. Wash off immediately.

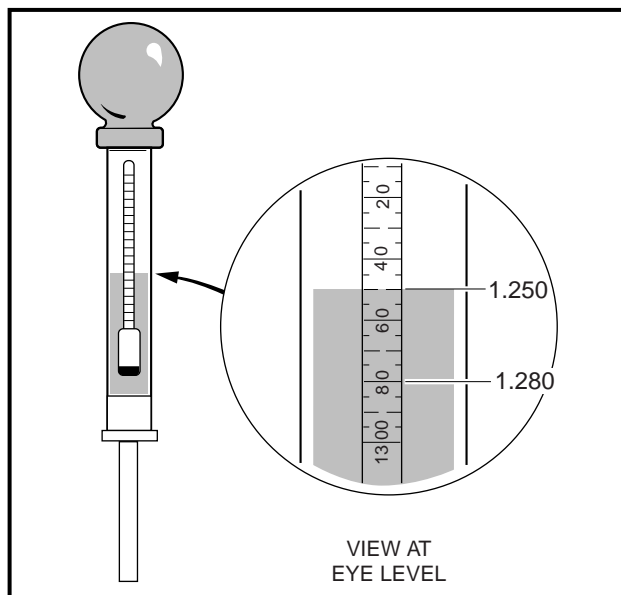

Figure 11-22 Hydrometer Test

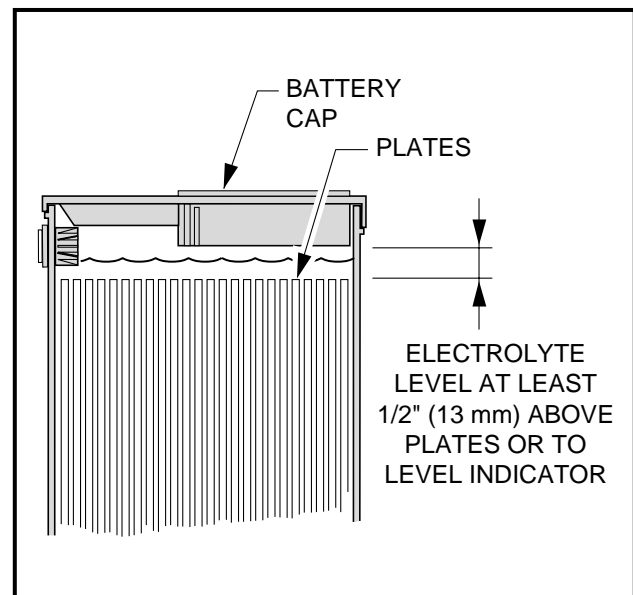

Figure 11-23 Battery Electrolyte Level

Performing the Hydrometer Test

1. Be sure that the battery has sufficient water to cover the plates by approximately 0.5 inch (12.7 mm) and is fully charged prior to beginning the test. If water must be added, recharge the battery before performing the hydrometer test (**Figure 11-23, Page 11-22**).
2. Remove the vent cap.
3. Using a battery thermometer (CCI 1011767), record the electrolyte temperature of a center cell.
4. Squeeze the rubber bulb of the hydrometer and insert into the cell. Slowly release the bulb, drawing electrolyte up into the glass tube of the hydrometer.
5. When the float rises off the bottom, adjust the electrolyte level so that the float rides free of the bottom but does not strike the bottom of the rubber bulb. Remove the hydrometer from the cell and release the pressure from the bulb.

6. Hold the hydrometer vertically, ensuring that the float is not contacting the sides of the glass tube. Hold the hydrometer at eye level and read the scale at the level of electrolyte (**Figure 11-22, Page 11-22**).
7. Record the reading.
8. Return the electrolyte to the cell from which it was taken. Replace vent cap.
9. Repeat steps 2 through 8 on all cells.

Hydrometer Calibration

Most hydrometers are calibrated to read correctly at 80 °F (27 °C). The readings obtained as described above must be corrected for temperature. For each 10 °F (5.6 °C) above 80 °F (27 °C), add 0.004 to the reading. For each 10 °F (5.6 °C) below 80 °F (27 °C), subtract 0.004 from the reading.

Interpreting the Results of the Hydrometer Test

The approximate state of charge can be determined by referring to the following table:

SPECIFIC GRAVITY AT 80 °F (27 °C)	STATE OF CHARGE
1.250 - 1.280	100%
1.220 - 1.240	75%
1.190 - 1.210	50%
1.160 - 1.180	25%

If the difference between the cells is 0.020 or more, the low cell should be suspected. It may require a catch-up charge or it may be a weak cell. When the variations between cells reach 0.050 or more, the battery should be replaced.

Voltage Test

1. Place the red (+) probe of a multimeter set at Volts DC, 20 volt range, on the positive (+) post and place the black (–) probe on the negative (–) post of the battery and take a voltage reading. If it shows less than 12.4 volts, or if the lowest specific gravity reading from the Hydrometer Test is less than 1.225, recharge the battery. If battery voltage is greater than 12.4 volts and specific gravity is greater than 1.225, the problem is not with the battery. If the battery does not reach 12.4 volts, or if the specific gravity of a cell is still less than 1.225 after charging, replace the battery. **See following NOTE.**

NOTE: A fully charged battery that is in good condition should have a specific gravity of at least 1.225 in all cells, and the difference in the specific gravity of any two cells should be less than 50 points. Open circuit voltage should be at least 12.4 volts.

Load Test

1. Using a 160 ampere load tester, connect the load tester to the battery posts.
2. Turn the switch on the load tester to the ON position.

3. Read the battery voltage after the load tester has been turned ON for 15 seconds. Compare the battery's voltage reading with the table below. Make sure you have the correct ambient temperature.

IF TEMPERATURE IS	MINIMUM VOLTAGE REQUIRED IS
70 °F (20 °C and above)	9.6V
60 °F (16 °C)	9.5V
50 °F (10 °C)	9.4V
40 °F (4 °C)	9.3V
30 °F (-1 °C)	9.1V
20 °F (-7 °C)	8.9V
10 °F (-12 °C)	8.7V
0 °F (-18 °C)	8.5V

4. If the battery is found to be good, or if the electrical problem continues after the battery has been replaced with a good one, test the electrical circuits.

TEST PROCEDURE 2 – FUSE

Read **DANGER** and **WARNING** on page 11-1.

The fuse (red 10 amp) is located in the electrical component box.

1. Place the Forward/Reverse handle in the NEUTRAL position, chock the wheels, and disconnect the battery cables, negative cable (–) first.
2. Remove the cover on the electrical component box.
3. Check that wires are connected correctly and are tight. If they are not, rewire or tighten as necessary.
4. Remove fuse to be tested from the fuse block. **See Fuse Removal, Section 12, Page 12-18.** The red 10 amp fuse protects the solenoid for the starter (cranking) circuit. The 20 amp fuse at the yellow wire connection protects the headlights.
5. Connect the probes of a multimeter set to 200 Ω (ohms) to the fuse terminals. The reading should be continuity. If there is no continuity, determine and repair the cause of the fuse failure. Replace the fuse with a properly rated new one.

TEST PROCEDURE 3 – GROUND STRAPS

Read **DANGER** and **WARNING** on page 11-1.

1. Place the Forward/Reverse handle in the NEUTRAL position, chock the wheels and disconnect the battery cables, negative cable (–) first.
2. Check the starter/generator ground strap.

2.1. Set the multimeter to 200 Ω (ohms). Place the red (+) probe on the (A2) terminal of the starter/generator and place the black (-) probe on the vehicle frame (**Figure 11-24, Page 11-25**). The reading should be continuity. If the reading is incorrect, clean and tighten wire connections. If the connections are good and the reading is incorrect, repair or replace the wire.

3. Check the engine ground strap.

3.1. Place the red (+) probe of the multimeter on the ground strap terminal end located on the oil filler bracket on the engine (**Figure 11-25, Page 11-25**). Place the black (-) probe on the vehicle frame. The reading should be continuity. If the reading is incorrect, clean and tighten wire connections. If the connections are good and the reading is incorrect, repair or replace the wire.

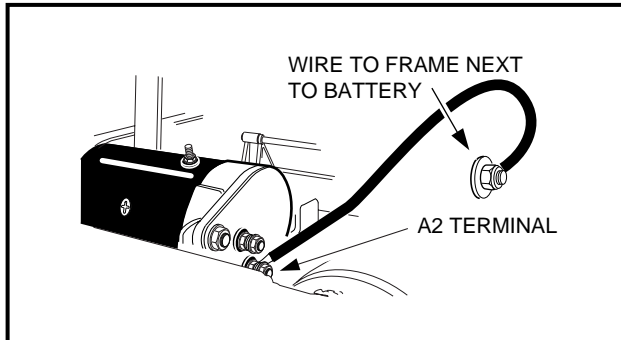

Figure 11-24 Test Starter/Generator Ground Strap

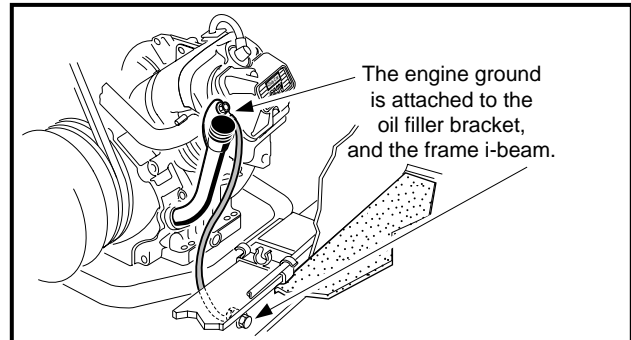

Figure 11-25 Test Engine Ground Strap

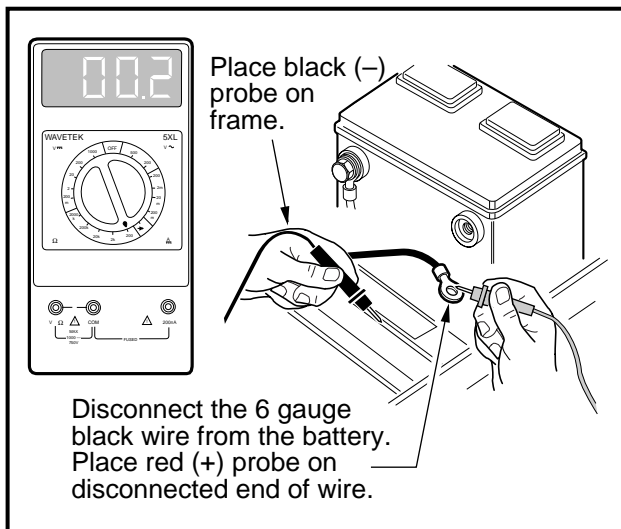

Figure 11-26 Battery Ground Cable Test

4. Check voltage regulator ground connection (at battery frame ground). Make sure it is clean and tight.

5. Check the battery ground cable.

5.1. A 6 gauge black wire connects the negative battery post to the frame. The frame connection should be clean and tight. Visual inspection of the connection on the frame is very difficult. The best check for tightness is to pull on the black wire. If the wire moves at the connection end, disassemble the frame connection and clean the bolt, ring terminal, and nut. Reinstall the frame connection.

5.2. Set the multimeter to 200 Ω (ohms). Place the red (+) probe on the unconnected end of the 6 gauge black wire, and place the black (-) probe on the vehicle frame (**Figure 11-26, Page 11-25**). The reading should be continuity. If the reading is incorrect, check that terminal connections are clean and tight. If the connections are good and the reading is incorrect, repair or replace the wire.

TEST PROCEDURE 4 – KEY SWITCH (STARTER CIRCUIT)

Read **DANGER** and **WARNING** on page 11-1.

1. Place the Forward/Reverse shifter handle in the NEUTRAL position, chock the wheels and disconnect battery, negative cable first.
2. Remove the center dash assembly. **See Key Switch Removal, Section 12, Page 12-15.**
3. Ensure that the connector is connected correctly and is tight. If it is not, repair or replace as necessary.
4. Insert the key and turn the key to ON. Place the red (+) probe of the multimeter on the (B) terminal and the black (–) probe on the (L) terminal of the key switch. The reading should be continuity. If the reading is incorrect, replace the key switch (**Figure 11-27, Page 11-26**). **See Key Switch Removal, Section 12, Page 12-15.**
5. With the key still in the ON position, place the red (+) probe of the multimeter on the (B) terminal and the black (–) probe on the (S) terminal of the key switch. The reading should show no continuity. If the reading is incorrect, replace the key switch. **See Key Switch Removal, Section 12, Page 12-15.** If the reading is correct, leave the probes connected and proceed to the next step.
6. Insert the key and hold the key in the START position. The reading should be continuity. If the reading is incorrect, replace the key switch (**Figure 11-28, Page 11-26**). With the red (+) probe of the multimeter on the (B) terminal and the black (–) probe on the (L) terminal of the key switch, the reading should be continuity. If either reading is incorrect, replace the key switch. **See Key Switch Removal, Section 12, Page 12-15.**

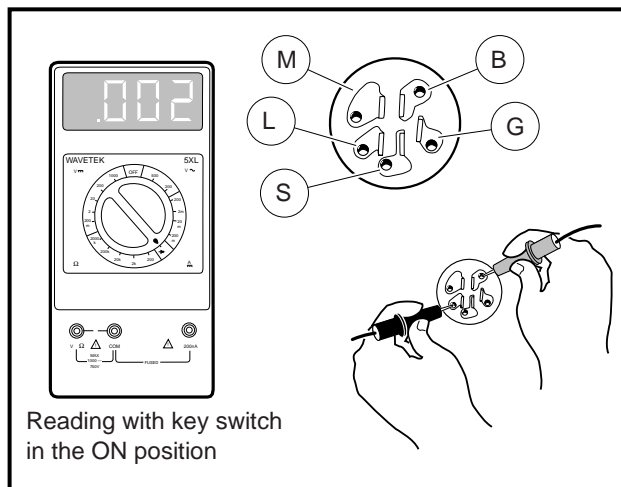

Figure 11-27 Key Switch Test – Accessory Terminal

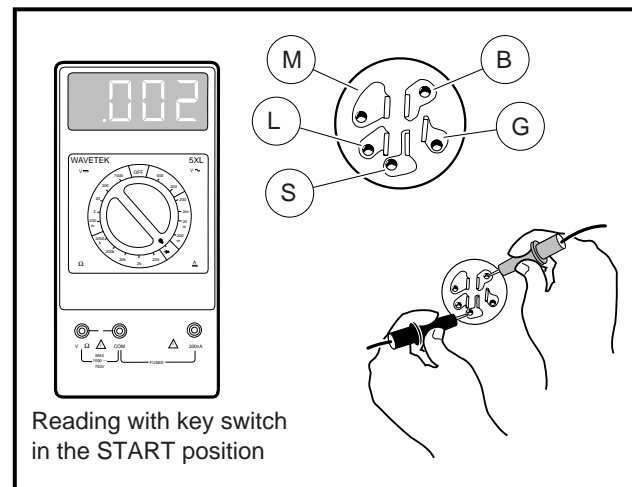

Figure 11-28 Key Switch Test – Starter Circuit

TEST PROCEDURE 5 – KEY SWITCH (ACCESSORY TERMINAL)

Read **DANGER** and **WARNING** on page 11-1.

1. Place the Forward/Reverse handle in the NEUTRAL position, chock the wheels, and disconnect the battery cables, negative cable (–) first.
2. Remove the center dash assembly. **See Key Switch Removal, Section 12, Page 12-15.**
3. Ensure that the connector is connected correctly and is tight. If it is not, repair or replace as necessary.

- Insert the key and turn the switch to the ON position. With the multimeter set to 200 Ω (ohms), place the red (+) probe of the multimeter on the (B) terminal and the black (-) probe on the (L) terminal of the key switch (**Figure 11-27, Page 11-26**). The reading should be continuity. If the reading is incorrect, replace the key switch. **See Key Switch Removal, Section 12, Page 12-15.**

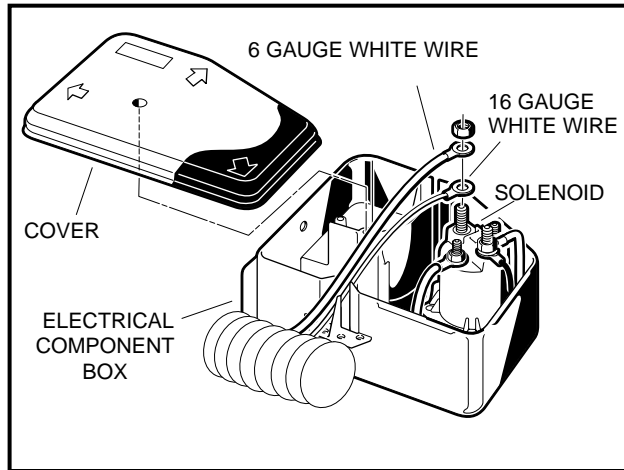

Figure 11-29 Remove Solenoid Wires

TEST PROCEDURE 6 – SOLENOID

Read **DANGER** and **WARNING** on page 11-1.

- Place the Forward/Reverse handle in the NEUTRAL position, chock the wheels and disconnect battery, negative cable first.
- Remove the electrical component box cover.
- Check that the wires are connected correctly and are tight. If they are not, rewire or tighten as necessary.
- Set a multimeter to 200 Ω (ohms). Place the red (+) probe on one of the small posts of the solenoid and place the black (-) probe on the other small post. The reading should be 14 to 16 Ω (ohms). If the reading is not within limits, replace the solenoid.
- Remove the 6 and 12 gauge white wires from the large post of the solenoid. Do not allow the wires to touch the frame or other components of the vehicle (**Figure 11-29, Page 11-27**).
- Set the multimeter to 200 Ω (ohms). Connect the red (+) probe to one of the large posts of the solenoid and connect the black (-) probe to the other large post (**Figure 11-30, Page 11-28**).
- With the key switch in the OFF position, connect the battery, positive cable first.
- Place the Forward/Reverse handle in NEUTRAL. With the key in the OFF position, the reading on the multimeter should be **NO** continuity. Turn the key switch to the START position and listen for the solenoid click. While holding the key in the START position, there should be continuity. After the key is released, it should rotate to the ON position and should be **NO** continuity. If either reading is incorrect, replace the solenoid.
- With the Forward/Reverse handle still in NEUTRAL, set the multimeter to 20 volts DC and place the red (+) probe on the large post that does *not* have wires connected to it. Place the black (-) probe on the vehicle frame. Turn key switch to the START position and listen for the solenoid click. While holding the key in the START position, the meter should read full battery voltage. If the reading is incorrect, replace the solenoid (**Figure 11-31, Page 11-28**).

10. Disconnect the 6 gauge black wire from the negative post of the battery before reconnecting the wires to the solenoid.
11. Reconnect the solenoid. **See Solenoid Installation, Section 12, Page 12-17. See also following WARNING.**

⚠ WARNING

- **Incorrect wiring could result in severe injury or death.**
- **Diode and solenoid connections must have correct polarity.**
- **Keep all persons clear of engine belts when making final connections.**

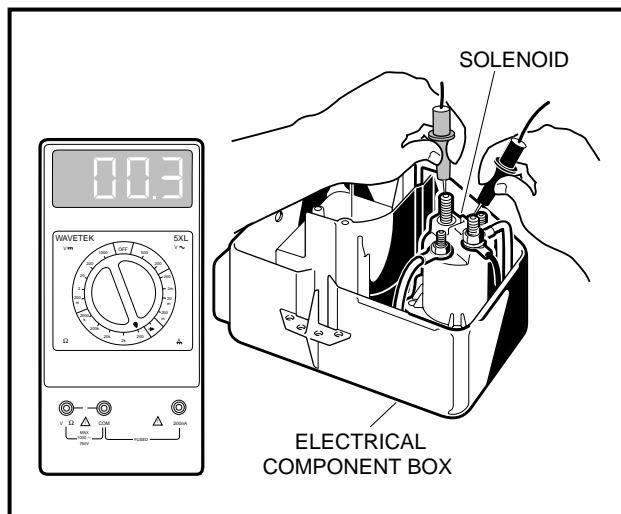

Figure 11-30 Test Solenoid Continuity

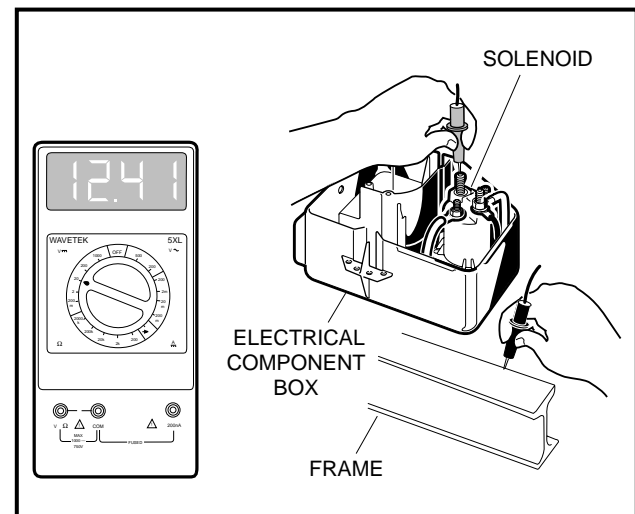

Figure 11-31 Test Solenoid Ground

TEST PROCEDURE 7 – LOCKOUT CAM LIMIT SWITCH

Read **DANGER** and **WARNING** on page 11-1.

This switch is located on the Forward/Reverse switch assembly. A black wire and a green wire are connected to this limit switch.

1. Place the Forward/Reverse handle in the NEUTRAL position, chock the wheels and disconnect the battery cables, negative cable (–) first.
2. Check for proper wiring and tight connections.
3. Set the multimeter to 200 Ω (ohms). Place the red (+) probe of the multimeter on the common (COM) terminal of the limit switch. Place the black (–) probe on the normally open (NO) terminal of the switch. Without the lever depressed, the reading should be **NO** continuity. Depress the lever, and the reading should be continuity. If either reading is incorrect, replace the limit switch (**Figure 11-32, Page 11-29**).
4. Check to be sure the lobes on the cam are depressing the lockout cam limit switch when the Forward/Reverse shifter is in the NEUTRAL position only. The limit switch should make an audible click as it is depressed. If it does not, check for wear on the cam lobe. If the cam lobe will not activate the limit switch, replace the cam.

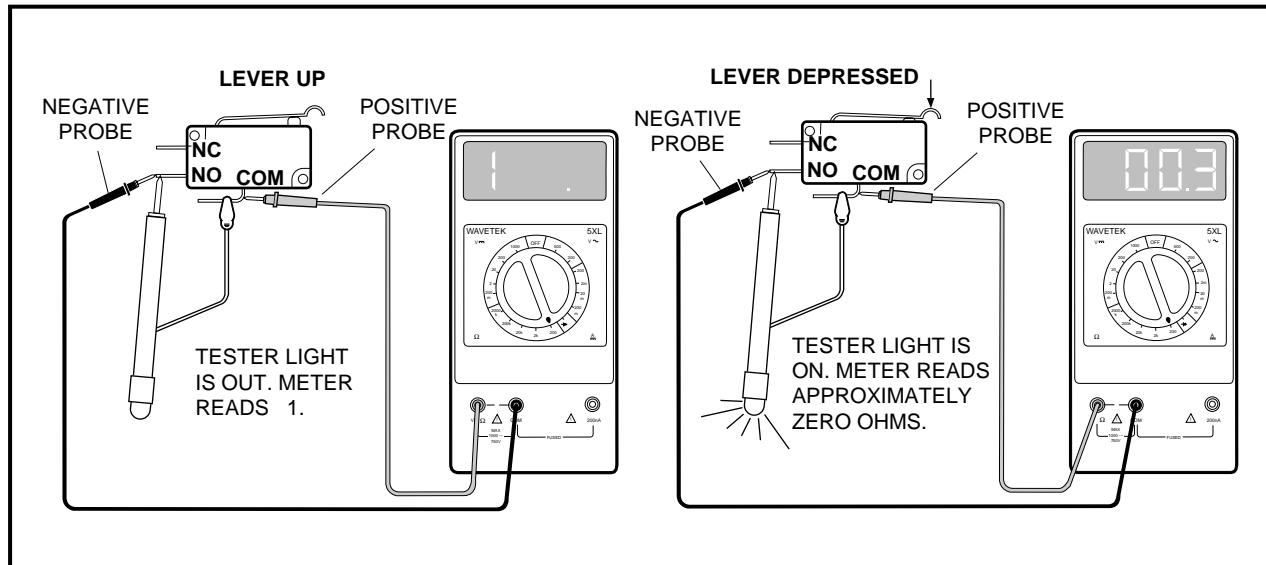

Figure 11-32 Test Lockout Cam Limit Switch

TEST PROCEDURE 8 – STARTER/GENERATOR (STARTER FUNCTION)

Read **DANGER** and **WARNING** on page 11-1.

1. Turn the key switch OFF, place the Forward/Reverse handle in the NEUTRAL position, chock the wheels and disconnect the battery cables, negative cable (–) first.
2. Check that wires are connected correctly and are tight. If they are not, rewire or tighten as necessary.
3. Disconnect the wires from all the terminals on the starter/generator. Then place the black (–) probe of a multimeter, set to Ω (ohms), on the starter/generator housing (scratch through the finish to ensure a good ground). While holding the black probe against the housing, place the red (+) probe (one at a time) on the A1, A2, F1, F2 and DF terminals respectively (**Figure 11-33, Page 11-30**). The readings should be **NO** continuity. If the readings are incorrect, the starter/generator will need to be removed from the vehicle and disassembled by a qualified technician. **See Starter/Generator Removal, Section 12, Page 12-2.**
 - An incorrect reading from the A1 or A2 terminal indicates three possible problems: 1) a grounded A1 or A2 terminal, 2) a grounded wire in the brush area, or 3) a grounded armature/commutator.
 - If the F1 or F2 reading is incorrect, it indicates a possible grounded F1 or F2 terminal or a grounded field coil.
 - If the DF reading is incorrect, it indicates a possible grounded DF terminal or a grounded field coil.
4. Disconnect the ground wire from the A2 terminal and the green wire from the A1 terminal on the starter/generator.
5. Using a multimeter set to 200 Ω (ohms), place the red (+) probe on the A1 terminal and the black (–) probe on the A2 terminal. The reading should be continuity. If the reading is incorrect, a possible open or poor contact in a brush assembly and/or open armature windings may be the cause. The starter/generator will need to be removed from the vehicle and disassembled by a qualified technician. **See Starter/Generator Removal, Section 12, Page 12-2.**

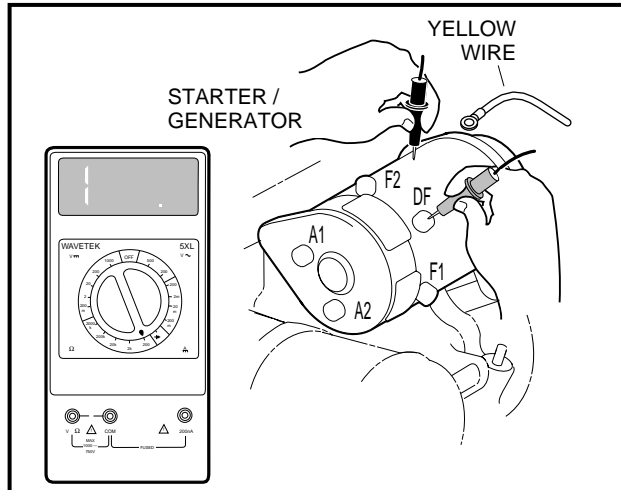

Figure 11-33 Check Starter Terminal Continuity

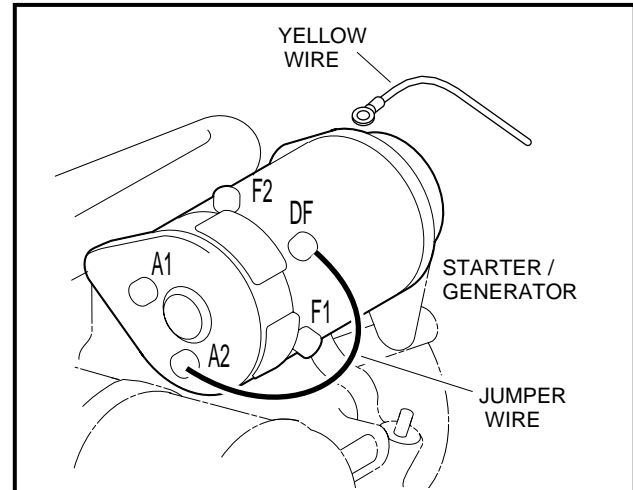

Figure 11-34 Jumper Wire Ground – DF to A2

6. With the wires still disconnected, using a multimeter set on 200 Ω (ohms), place the red (+) probe on the F1 terminal and the black (–) probe on the F2 terminal. The reading should be between approximately 0.1 and 0.3 Ω (ohms). If the reading is incorrect, a possible open field coil or bad connections at terminals may be the cause. The starter/generator will need to be removed from the vehicle and disassembled by a qualified technician. **See Starter/Generator Removal, Section 12, Page 12-2.**
7. With the wires still disconnected, using a multimeter set to 200 Ω (ohms), place the red (+) probe on the DF terminal and the black (–) probe on the F1 terminal. The reading should be between 4.5 and 5.5 Ω (ohms). If the reading is incorrect, a possible grounded DF terminal and/or grounded field coil may be the cause. The starter/generator will need to be removed from the vehicle and disassembled by a qualified technician. **See Starter/Generator Removal, Section 12, Page 12-2.**

TEST PROCEDURE 9 – WIRE CONTINUITY

Read **DANGER** and **WARNING** on page 11-1.

1. Place the Forward/Reverse handle in the NEUTRAL position, chock the wheels and disconnect the battery cables, negative cable (–) first.
2. To test a wire for continuity, disconnect either end from the electrical component it is attached to.
3. Set the multimeter to 200 Ω (ohms) and place the red (+) probe on the terminal at one end of the wire. Place the black (–) probe on the other terminal end of the wire. The reading should be continuity. If the reading is incorrect, repair or replace the wire.

TEST PROCEDURE 10 – DIODE (GENERATOR CIRCUIT)

Read **DANGER** and **WARNING** on page 11-1.

1. Place the Forward/Reverse handle in the NEUTRAL position, chock the wheels, and disconnect the battery cables, negative cable (–) first.
2. Disconnect the two wires from the diode assembly, which is located on the I-beam close to the battery.

- With the multimeter set to the diode test function ($\rightarrow|$), connect the black (-) probe of the multimeter to the (+) terminal of the diode and the red (+) probe on the other terminal of the diode (**Figure 11-35, Page 11-31**). The reading should be approximately 960 mV.

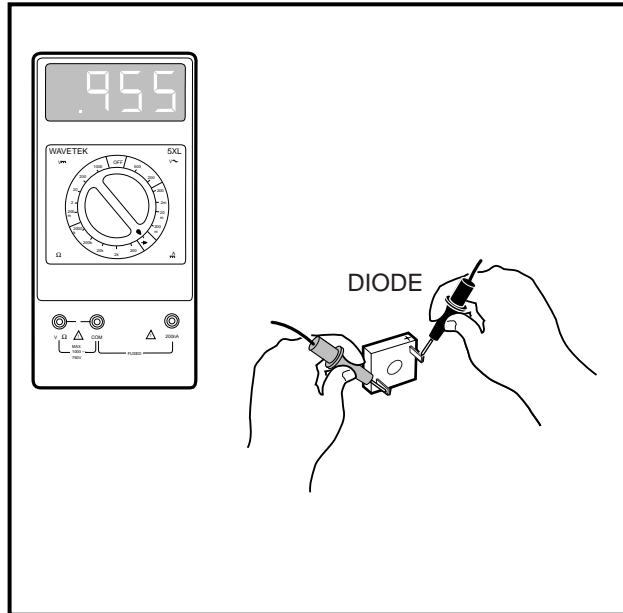

Figure 11-35 Diode Test

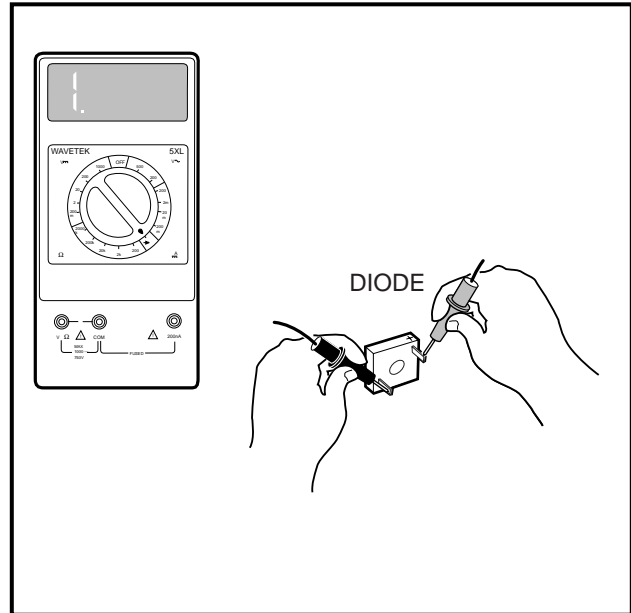

Figure 11-36 Diode Test – Probes Reversed

- Reverse the multimeter probes and note the reading. The multimeter should indicate an overload (no continuity) (**Figure 11-36, Page 11-31**). A diode is designed to conduct current in one direction only. If a diode conducts current (shows continuity) in both directions, the diode has failed and must be replaced. If a diode does not conduct current (does not show continuity) in either direction, the diode has failed and must be replaced. **See Diode Removal, Section 12, Page 12-14.**
- Reconnect the diode. **See Diode Installation, Section 12, Page 12-15. See also following WARNING.**

⚠ WARNING

- Incorrect wiring could result in severe injury or death.
- Diode and solenoid connections must have correct polarity.
- Keep all persons clear of engine belts when making final connections.

TEST PROCEDURE 11 – STARTER/GENERATOR (GENERATOR FUNCTION)

Read DANGER and WARNING on page 11-1.

NOTE: Perform Test Procedure 10 before proceeding with this test procedure.

Keep the battery connected while performing this test procedure.

- Place the Forward/Reverse handle in the NEUTRAL position, and chock the wheels.
- Ensure that the wires are connected correctly and are tight. If they are not, rewire or tighten as necessary.

3. Disconnect the yellow wire from the DF terminal on the starter/generator. Cover the connector on the yellow wire to make sure the yellow wire will not short to ground. Then, using a jumper wire, ground the DF terminal to the A2 terminal (**Figure 11-34, Page 11-30**).
4. Using a multimeter set to 20 volts DC, place the red (+) probe on the positive (+) post of the battery, and place the black (-) probe on the negative (-) post. Start the engine and run it at full governed speed. The reading should show the voltage rising on the meter. If the voltage rises, see Test Procedure 12 – Voltage Regulator on page 11-32. If the voltage does not rise, and the diode was found to be functioning properly in Test Procedure 10, a tear-down inspection of the starter/generator will be necessary. **See Starter/Generator Removal, Section 12, Page 12-2.**
5. Reconnect the yellow wire to the DF terminal on the starter/generator.

TEST PROCEDURE 12 – VOLTAGE REGULATOR

Read DANGER and WARNING on page 11-1.

NOTE: Perform Test Procedures 10 and 11 before proceeding with this test procedure.

Keep the battery connected while performing this test procedure.

1. Place the Forward/Reverse handle in the NEUTRAL position, and chock the wheels.
2. Check that the wires are connected correctly and are tight. If they are not, rewire or tighten as necessary.
3. Check the engine RPM setting to ensure that it is adjusted correctly. **See Engine RPM Adjustment, Section 14, Page 14-13.**
4. With the battery in good condition and fully charged, run the engine for several minutes to bring the voltage regulator to operating temperature.
5. Turn the key switch to the OFF position, killing the engine. Using a multimeter set to 20 volts DC, place the red (+) probe on the large post of the solenoid with the red wire from the voltage regulator attached. Place the black (-) probe on the negative (-) battery post (**Figure 11-37, Page 11-33**). With the Forward/Reverse handle in the NEUTRAL position and the wheels chocked, turn the key switch to the START position to start the engine. Depress the accelerator to run the engine at full governed speed. If the reading is between 14.7 and 15.3 volts, the regulator is good. If the reading is lower than 14.7 volts but rising steadily, check battery condition. **See Hydrometer Test on page 11-22.** If the reading is lower than 14.7 volts and not rising, and the starter/generator is good; or if the reading is over 15.3 volts and continues to rise, replace voltage regulator. **See Voltage Regulator Removal, Section 12, Page 12-13.**

TEST PROCEDURE 13 – DISCONNECTED KILL WIRE

Read DANGER and WARNING on page 11-1.

NOTE: Keep the battery connected while performing this test procedure.

1. Place the Forward/Reverse handle in the NEUTRAL position, and chock the wheels.
2. Disconnect the engine-kill white/black wire at the bullet connector located next to the RPM limiter (**Figure 11-39, Page 11-34**).
3. With the wheels chocked, connect the 6 gauge red wire to the positive post on the battery, then connect the 6 gauge black wire to the negative post.

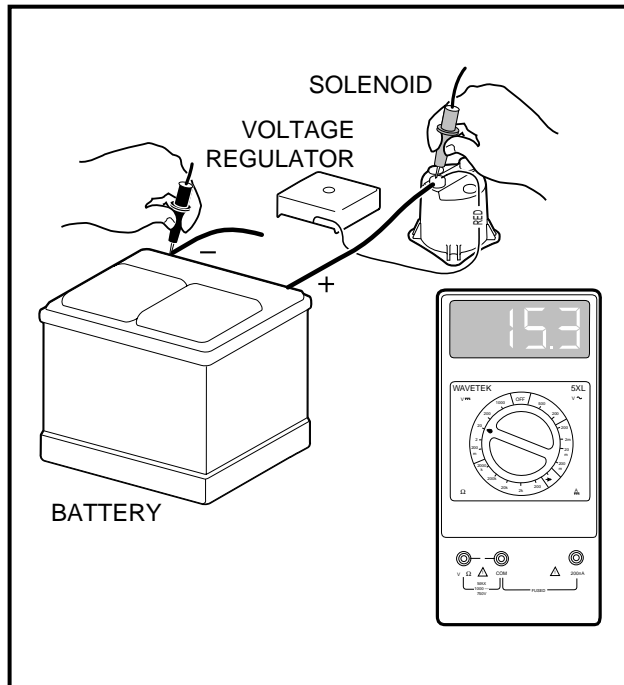

Figure 11-37 Test Voltage Regulator

4. Turn the key switch all the way to the START position and release after the engine is running. The engine should idle.
5. If the engine begins to run, test the engine kill circuit for a shorted wire or other failed components in the engine kill circuit. **See Testing the Engine Kill Circuit on page 11-16. See following WARNING.**

⚠ WARNING

- When the white/black engine kill wire is disconnected, the engine will not stop running after the key switch is turned to the OFF position. It will be necessary to pull and hold the choke handle until the engine stops running.

6. If the engine does not run, proceed to Test Procedure 14 – Ignition Spark on page 11-33.

TEST PROCEDURE 14 – IGNITION SPARK

Read **DANGER** and **WARNING** on page 11-1.

NOTE: Keep the battery connected while performing this test procedure.

1. Place the Forward/Reverse handle in the NEUTRAL position, and chock the wheels.
2. Remove the plug wire from the spark plug. Using an ignition spark gap test tool (Thexton 404[®] or equivalent), check for correct spark (**Figure 11-38, Page 11-34**).

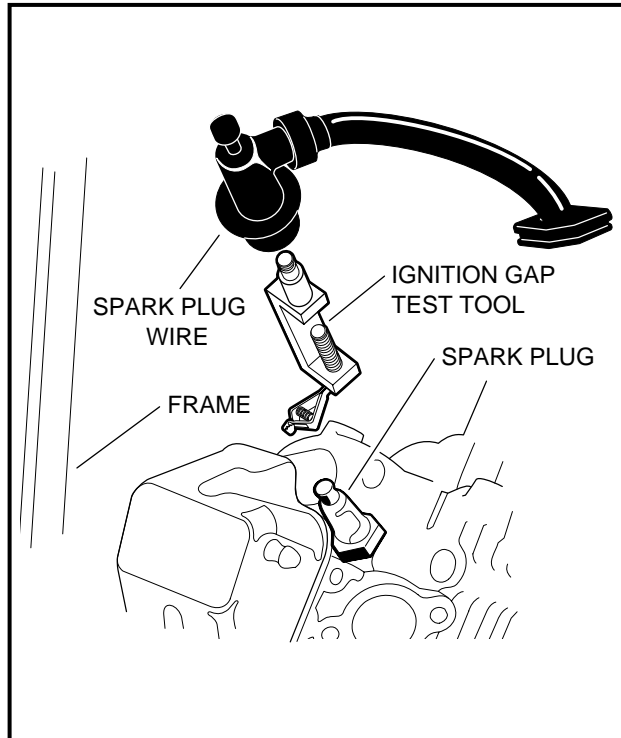

Figure 11-38 Ignition Spark Test

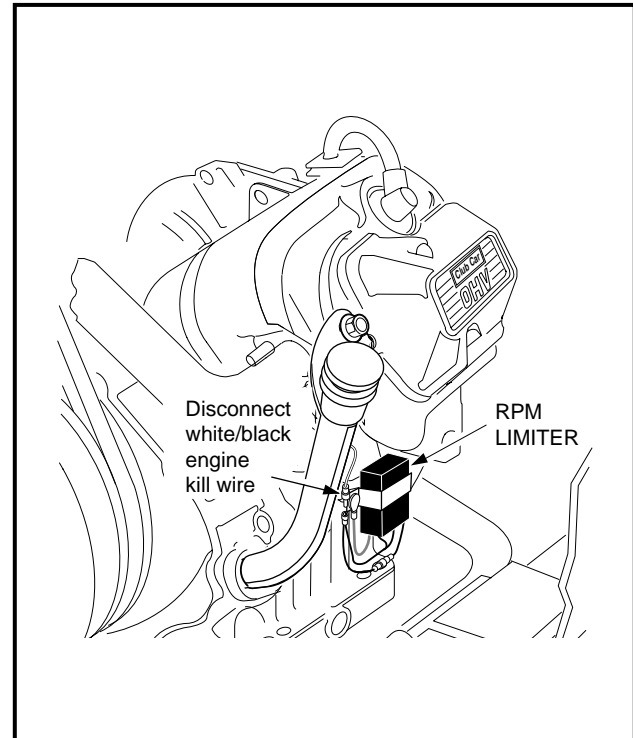

Figure 11-39 Disconnect White/Black Engine Kill Wire

- 2.1. Adjust the tester probes to approximately to 18,000 volts (18 Kv) setting (SE – *Small Engine Setting* on the Thexton 404 tool). Connect the tester to the spark plug wire, and connect the alligator clip to a solid engine ground.
- 2.2. Start the engine. There should be a strong blue spark between the probes of the spark gap tester. If there is no spark, or if the spark is a faint yellow or red color, test components of the ignition circuit.
3. If the spark gap tester tool indicates a strong blue spark, it is possible the spark plug has failed internally. Check the spark plug gap. The gap should be set at 0.027 to 0.031 of an inch (.69 to .79 mm). If the gap is correct, replace the spark plug with a new part and test the engine for proper operation.

TEST PROCEDURE 15 – RPM LIMITER

Read **DANGER** and **WARNING** on page 11-1.

1. Place the Forward/Reverse handle in the NEUTRAL position, chock the wheels and disconnect the battery cables, negative cable (–) first.
2. Disconnect both of the bullet terminals (**Figure 11-40, Page 11-35**).
3. Using a multimeter set to 200 Ω (ohms), place the red (+) probe on the brown ground wire and place the black (–) probe on one of the black wire female bullet connectors. The reading should be no continuity. If the reading is not correct, replace the RPM Limiter.
4. This test will find most bad RPM Limiters. Some of them may bench test okay but fail under a load due to heat while operating. Another method of testing is to replace the RPM Limiter and then run the engine. If the engine runs properly, keep the new RPM Limiter in the circuit.

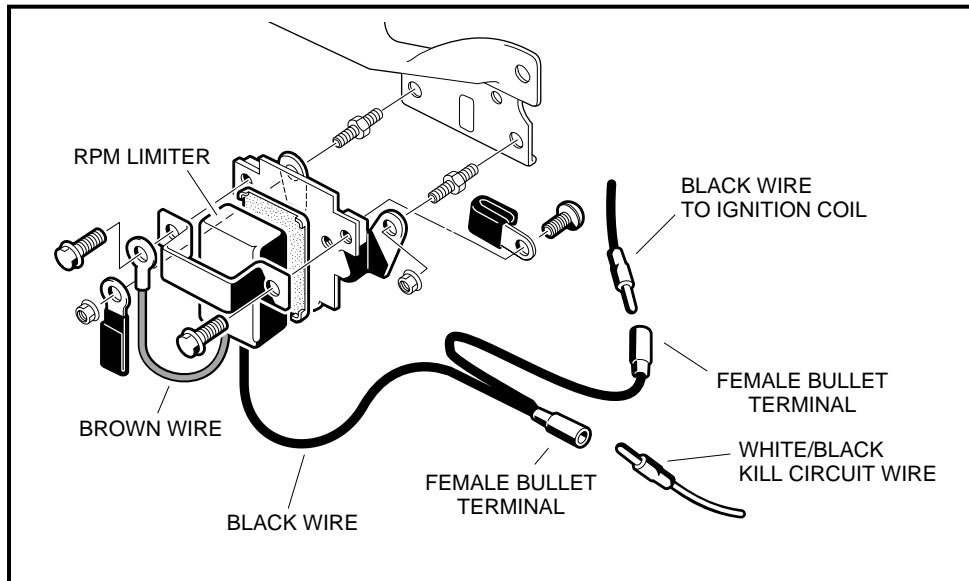

Figure 11-40 RPM Limiter

TEST PROCEDURE 16 – IGNITION COIL

Read **DANGER** and **WARNING** on page 11-1.

1. Place the Forward/Reverse handle in the NEUTRAL position, chock the wheels and disconnect the battery cables, negative cable (–) first.
2. Using a multimeter set to 200 Ω (ohms), measure the primary coil resistance.
 - 2.1. Disconnect both of the bullet terminals at the RPM limiter. Place the black (–) probe of the meter on the male bullet terminal of the wire connecting to the coil under the fan housing, and place the red (+) probe on a clean unpainted surface of the engine or frame (**Figure 11-40, Page 11-35**).
 - 2.2. If the resistance is not between 0.6 - 1.7 Ω (ohms), remove the coil from the engine. **See Ignition Coil Removal, Section 12, Page 12-25**. Retest with a multimeter set to 200 Ω (ohms). Place the black (–) probe of the meter into the terminal on the coil (1), and place the red (+) probe on the core (2) (**Figure 11-41, Page 11-36**). If the resistance is still not between 0.6 - 1.7 Ω (ohms), replace the coil.
3. Using a multimeter set to 20k Ω (ohms), measure the secondary coil resistance.
 - 3.1. Remove the spark plug wire from the spark plug. Place the red (+) probe of the meter into the end of the spark plug wire and place the black (–) probe on a clean, unpainted surface of the engine or frame.
 - 3.2. If the resistance is not between 6.0k - 11.0k Ω (ohms), remove the coil from the engine. **See Ignition Coil Removal, Section 12, Page 12-25**. Retest with a multimeter set to 20k Ω (ohms). Place the black (–) probe of the meter on the core (2), and place the red (+) probe into the end of the spark plug wire (3) (**Figure 11-42, Page 11-36**). If the resistance is not between 6.0k - 11.0k Ω (ohms), replace the coil.
4. These tests will find most of the bad coils. Some coils may bench test okay but fail under a load due to heat while operating. Another method of testing is to replace the coil and then run the engine. If the engine runs properly, keep the new coil in the circuit.

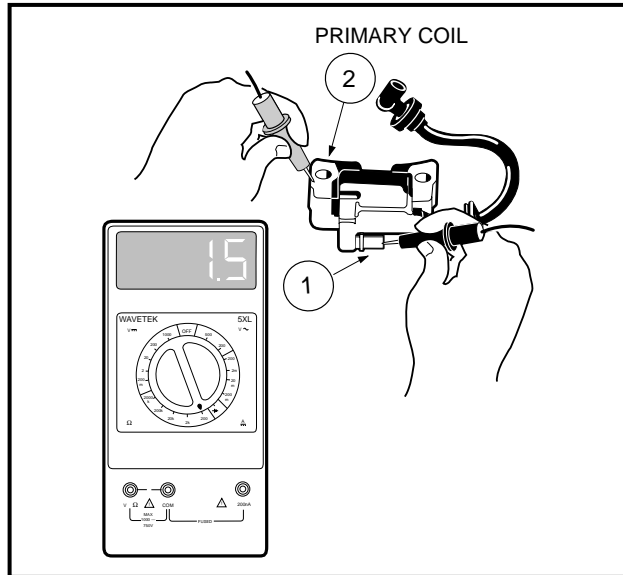

Figure 11-41 Test Ignition Primary Coil

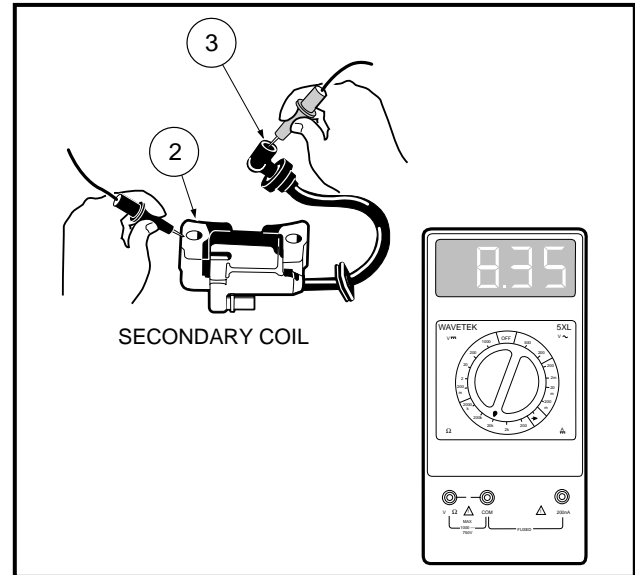

Figure 11-42 Test Ignition Secondary Coil

TEST PROCEDURE 17 – KEY SWITCH (ENGINE KILL CIRCUIT)

Read **DANGER** and **WARNING** on page 11-1.

1. Place the Forward/Reverse handle in the NEUTRAL position, chock the wheels and disconnect the battery cables, negative cable (–) first.
2. Remove the center dash assembly. See **Key Switch Removal, Section 12, Page 12-15**.
3. Remove the connector from the key switch.
4. Place the red (+) probe on the (M) terminal and the black (–) probe on the (G) terminal. With the key switch OFF, the reading should be continuity. With the key switch turned ON, the reading should be **NO** continuity. If either reading is incorrect, replace the key switch (**Figure 11-43, Page 11-36**).
5. Reconnect the key switch to the wire harness. Ensure that the connector is connected correctly and is tight. If it is not, repair or replace as necessary.

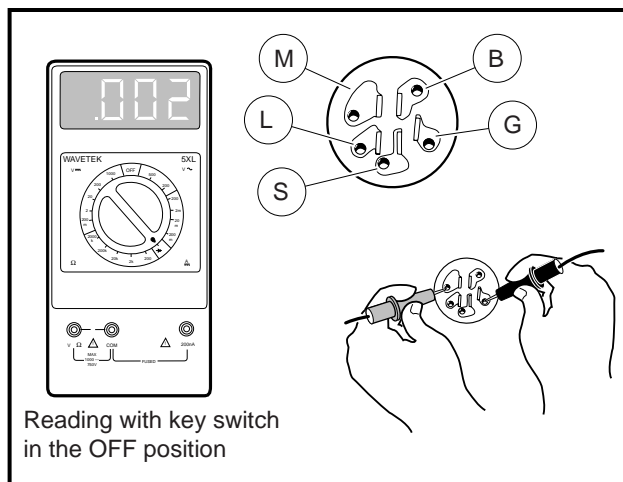

Figure 11-43 Test Key Switch – Engine Kill Circuit

TEST PROCEDURE 18 – ENGINE KILL WIRE

Read **DANGER** and **WARNING** on page 11-1.

1. Place the Forward/Reverse handle in the NEUTRAL position, chock the wheels and disconnect the battery cables, negative cable (–) first.
2. Disconnect white/black wire bullet connector located at the engine RPM limiter (**Figure 11-39, Page 11-34**).
3. Connect red (+) probe of multimeter to the male bullet terminal on the white/black wire and connect the black (–) probe to the vehicle frame.
4. With the Forward/Reverse handle in the NEUTRAL position, turn the key switch to the ON position and note the multimeter reading. Turn the key and hold it in the START position while noting the multimeter reading. There should be **NO** continuity when the key switch is in the ON or START position. If there is continuity, check for worn insulation on the white/black wire that is allowing the wire to ground to the frame.

TEST PROCEDURE 19 – REVERSE BUZZER LIMIT SWITCH

Read **DANGER** and **WARNING** on page 11-1.

NOTE: Keep the battery connected while performing this test procedure.

The reverse buzzer limit switch is located on the Forward/Reverse shifter; red/white and orange wires are connected to it.

1. Place the Forward/Reverse handle in the NEUTRAL position, and chock the wheels.
2. Move the Forward/Reverse handle to REVERSE and listen for an audible click from the limit switch. If there is no click, check the switch for proper alignment and switch arm movement.
3. If the switch is being activated but the buzzer does not function, place the red (+) probe of the multimeter on one terminal and the black (–) probe on the other terminal of the limit switch. Without the lever depressed, the reading should be **NO** continuity. Depress the lever and the reading should be continuity. If either reading is incorrect, replace limit switch (**Figure 11-7, Page 11-11**).

TEST PROCEDURE 20 – REVERSE BUZZER

Read **DANGER** and **WARNING** on page 11-1.

The reverse buzzer is mounted to the center dash assembly under the front body.

1. Place the Forward/Reverse handle in the NEUTRAL position, chock the wheels and disconnect the battery cables, negative cable (–) first.
2. To test the reverse buzzer, remove center dash panel. **See Key Switch Removal, Section 12, Page 12-15.**
3. Check for proper wiring and tight connections. Using a multimeter, individually check for continuity through each wire that connects to the reverse buzzer (**Figure 11-7, Page 11-11**). If the buzzer will not function when properly wired, replace the buzzer.

TEST PROCEDURE 21 – OIL LEVEL SENSOR

Read **DANGER** and **WARNING** on page 11-1.

NOTE: Keep the battery connected while performing this test procedure.

1. Place the Forward/Reverse handle in the NEUTRAL position, turn the key switch to the OFF position, disconnect the spark plug wire, and chock the wheels.
2. Ensure that the low oil warning light and all connecting wires are functioning correctly. **See Test Procedure 22 – Oil Warning Light on page 11-38.**
3. Drain the engine oil into an approved container and properly dispose of used oil.
4. Turn the key switch ON, closing the circuit. The oil light should illuminate. If the low oil warning light does not illuminate, the oil level sensor needs to be replaced. **See Oil Level Sensor Removal, Section 13, Page 13-24.**
5. Fill the engine with new oil and install a new oil filter before returning the vehicle to service. **See Engine Oil, Section 10, Page 10-6.**

TEST PROCEDURE 22 – OIL WARNING LIGHT

Read **DANGER** and **WARNING** on page 11-1.

1. Place the Forward/Reverse handle in the NEUTRAL position, chock the wheels and disconnect the battery cables, negative cable (–) first.
2. Remove the center dash assembly. **See Key Switch Removal, Section 12, Page 12-15.**
3. Ensure that the wires are connected correctly and are tight. If they are not, rewire or tighten as necessary (**Figure 11-8, Page 11-12**).
4. Disconnect the yellow wire (to the oil level sensor) from the terminal on the oil light. Using an alligator clip jumper wire, connect the oil light terminal to the vehicle frame. Connect the red (+) battery cable to the positive (+) battery post, then attach the black (–) cable to the negative (–) battery post.
5. Turn the key switch ON. The oil light should illuminate. If it does not, check continuity of the yellow wire that connects the key switch to the oil light. If there is **NO** continuity in the wire, replace the wire. Then test the key switch. **See Test Procedure 4 – Key Switch (Starter Circuit) on page 11-26.** If the yellow wire and the key switch test okay, then replace the oil light.

TEST PROCEDURE 23 – LOCKOUT CAM

Read **DANGER** and **WARNING** on page 11-1.

1. Check to be sure the lobes on the cam are depressing the lockout cam limit switch when the Forward/Reverse shifter is in the NEUTRAL position only. The limit switch should make an audible click as it is depressed. If it does not, check for wear on the cam lobe. If the cam lobe will not activate the limit switch, replace the cam.

TEST PROCEDURE 24 – BATTERY TEST (UNDER LOAD)**Read DANGER and WARNING on page 11-1.****NOTE:** Keep the battery connected while performing this test procedure.

1. Place the Forward/Reverse handle in the NEUTRAL position, and chock the wheels.
2. Set a multimeter to 20 volts and place the red (+) probe on the F2 (white wire) terminal on the starter/generator. Place the black (–) probe on the negative battery post.
3. Turn the key switch to the START position and hold it in the START position while noting the voltage reading on the multimeter (with the key in the START position the battery is under load).
 - 3.1. If the voltage reading is over 9.6 volts at 70 °F (21 °C) (electrolyte temperature) (**see following NOTE**), check the starter/generator.

NOTE: The voltage reading is taken at 70 °F (21 °C). At lower electrolyte temperatures the voltage reading will be lower.

- 3.2. If the reading is below 9.6 volts at 70 °F (21 °C) (electrolyte temperature), check the battery. **See Test Procedure 1 – Battery on page 11-21.**
- 3.3. If the reading is zero, there may be **NO** continuity across the large posts of the solenoid. **See Test Procedure 6 – Solenoid on page 11-27.**
4. If all of the test results are good and the voltage reading is zero, there may be a broken or damaged 6 gauge white wire from the solenoid to the starter/generator. **See Test Procedure 8 – Starter/Generator (Starter Function) on page 11-29.**

TEST PROCEDURE 25 – FUEL LEVEL SENDING UNIT**Read DANGER and WARNING on page 11-1.**** WARNING**

- **To avoid the possibility of fire or explosion, make sure the fuel tank cap is securely in place while performing this test procedure.**

1. Turn the key switch to the OFF position, put the Forward/Reverse handle in the NEUTRAL position, disconnect the battery cables, negative cable (–) first, and chock the wheels.
2. Disconnect the orange wire from the center post of the fuel level sending unit.
3. With a multimeter set to 2k Ω (ohms), place the red (+) probe of the multimeter on the center post of the sending unit. Place the black (–) probe on the ground connection of the sending unit (**Figure 11-44, Page 11-40**).
4. The following resistance readings (in ohms) should be obtained depending on the position of the float inside the fuel tank. The resistance reading will vary according to the exact position of the float. The chart below may be used as a guideline to determine if the fuel level sending unit is operating correctly. Make sure the float is at the surface of the fuel in the tank.

FLOAT POSITION	RESISTANCE READING	FUEL GAUGE READINGS
Lower Position (Tank Empty)	240 ± 20 Ω (ohms)	Empty
Center Position (Tank Half Full)	120 ± 20 Ω (ohms)	Half Full
Upper Position (Tank Full)	60 ± 20 Ω (ohms)	Full

5. If the readings are within the specifications listed above, the fuel level sending unit is working properly. If the readings are incorrect, the fuel level sending unit has failed and the fuel tank must be replaced. **See Fuel Tank Removal, Section 14, Page 14-24.**
6. If the readings are correct and the fuel gauge does not function correctly, check the continuity of the orange wire from the fuel level sending unit to the fuel/hour gauge. Leave the battery disconnected while checking continuity. Also check the continuity of the yellow wire from the fuel/hour gauge to the key switch, and the black ground wires at the fuel level sending unit and at the fuel/hour gauge. **See Fuel/Hour Gauge Removal, Section 12, Page 12-23.**
7. If the readings are correct according to the position of the float, but give an incorrect reading on the fuel/hour gauge, test the fuel/hour gauge. **See Test Procedure 26 – Fuel Gauge on page 11-40.**

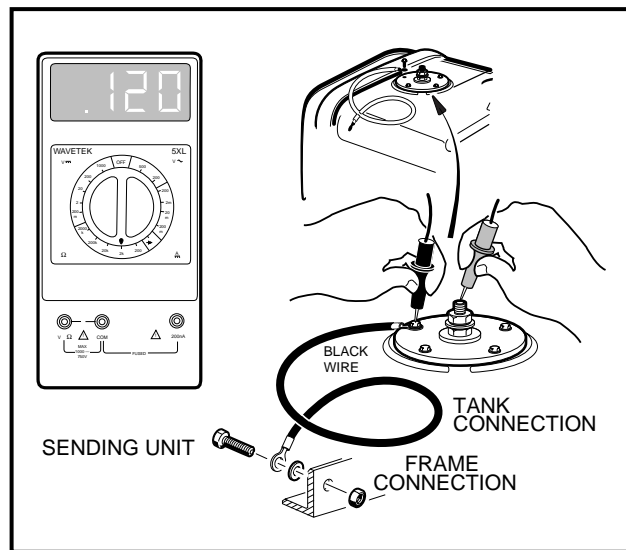

Figure 11-44 Test Fuel Level Sending Unit

TEST PROCEDURE 26 – FUEL GAUGE

Read **DANGER** and **WARNING** on page 11-1.

1. Place the Forward/Reverse handle in NEUTRAL, chock the wheels and disconnect the battery cables, negative cable (–) first.
2. Remove the center dash assembly to gain access to the back of the fuel/hour gauge. **See Key Switch Removal, Section 12, Page 12-15.**
3. Place a sheet of insulating material between the front frame and the electrical connections on the rear of the center dash assembly to prevent contact between the two.
4. Disconnect the orange wire from the fuel/hour gauge.
5. Set a multimeter to 20 volts DC and place the red (+) probe of the multimeter on the positive post of the battery. Place the black (–) probe on the negative post of the battery. Record the voltage reading.
6. Set a multimeter to 20 volts DC and place the red (+) probe of the multimeter on the (2) terminal of the fuel/hour gauge with the blue wire. Place the black (–) probe on the (3) terminal of the fuel/hour gauge with the black wire (**Figure 11-45, Page 11-41**).
7. Reconnect the battery cables, positive terminal first, and tighten to 20 ft-lb (27.1 N·m).
8. Turn the key switch ON. The voltage reading should be the same as the battery voltage reading recorded earlier. If not, check the continuity of the blue and black wires (**Figure 11-45, Page 11-41**).

9. The orange wire should remain disconnected for this step. With the black probe still on the (3) terminal of the fuel/hour gauge, place the red (+) probe of the multimeter on the (1) terminal of the fuel/hour gauge. The voltage reading should be the same as the full battery voltage reading obtained in step 5. If the reading is incorrect, replace fuel/hour gauge (**Figure 11-46, Page 11-41**).

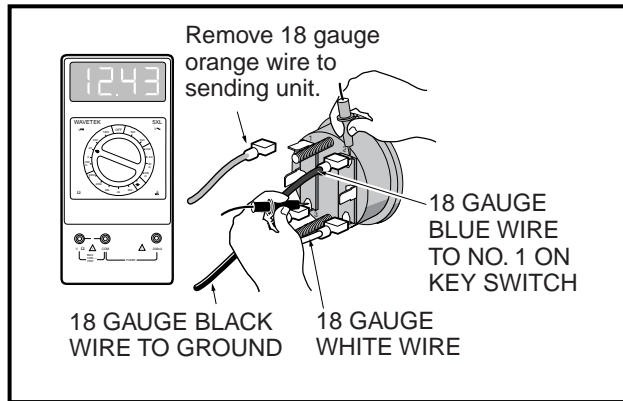

Figure 11-45 Fuel Gauge Test

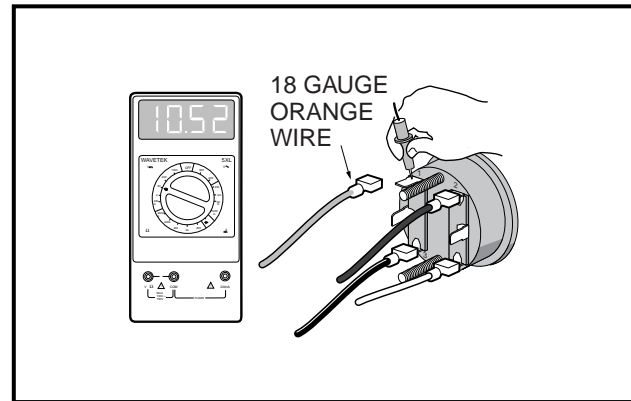

Figure 11-46 Fuel Gauge Voltage Test

TEST PROCEDURE 27 – HOUR GAUGE

Read **DANGER** and **WARNING** on page 11-1.

NOTE: Keep the battery connected while performing this test procedure.

1. Place the Forward/Reverse handle in the NEUTRAL position, and chock the wheels.
2. Turn the key switch to ON and record the current hour gauge reading.
3. Turn the key past the ON position to the START position and hold until the engine is running smoothly. Release the key and it will return to the ON position and the engine should idle.
4. Allow the engine to idle for at least six minutes (the meter records in six-minute increments). **See following DANGER.**

⚠ DANGER

- **Do not operate gasoline vehicle in an enclosed area without proper ventilation. The engine produces carbon monoxide, which is an odorless, deadly poison.**

5. If the reading does not change after six minutes, then replace the fuel/hour gauge.

TEST PROCEDURE 28 – LIGHT SWITCH

Read **DANGER** and **WARNING** on page 11-1.

1. Place the Forward/Reverse handle in NEUTRAL, chock the wheels and disconnect the battery cables, negative cable (–) first.
2. Remove the center dash assembly. **See Key Switch Removal, Section 12, Page 12-15.**
3. Using a multimeter set on 20 volts DC, place alligator clips on the multimeter probes. Connect the red (+) probe to the light switch terminal with the blue wire connected to it (**Figure 11-47, Page 11-42**).

⚠ CAUTION

- Before connecting battery cables, make sure none of the electrical components touch the front body trim or other parts of the vehicle frame. Place a dry towel between the body trim and the center dash to prevent an electrical short.

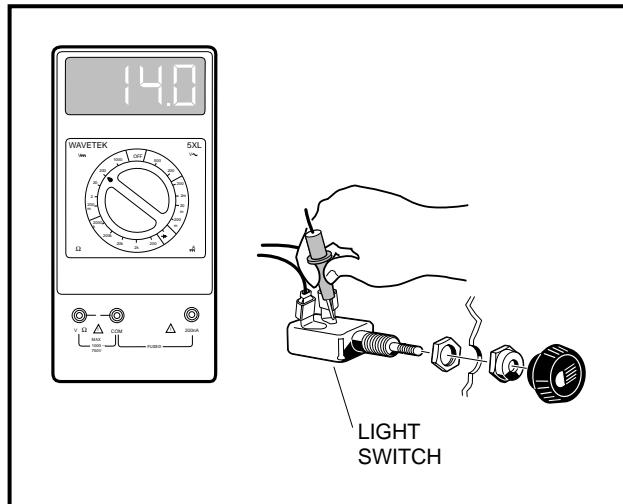

Figure 11-47 Light Switch Test

4. Connect the battery, positive cable first.
5. Connect the black (–) probe of the multimeter to the negative (–) post of the battery.
6. With the light switch in the OFF position, the reading should be zero volts. With the light in the ON position, the reading should be between 11 and 12.5 volts. If there is no voltage reading, check continuity of the 10 gauge red wire from the fuse block to the solenoid. Check continuity of the 14 gauge yellow wire from the light switch to the fuse block. Check the fuse. **See Test Procedure 2 – Fuse on page 11-24.** If the headlight diode is functioning correctly, the wires and fuse show continuity and the readings are still incorrect, replace the switch. **See Light Switch Removal, Section 12, Page 12-31.**

TEST PROCEDURE 29 – HEADLIGHT DIODE

Read **DANGER** and **WARNING** on page 11-1.

1. Place the Forward/Reverse handle in NEUTRAL, chock the wheels and disconnect the battery cables, negative cable (–) first.
2. Remove the center dash assembly. **See Key Switch Removal, Section 12, Page 12-15.**
3. Using a multimeter set on 20 volts DC, connect the red (+) probe to the light switch terminal with the yellow wire (**Figure 11-48, Page 11-43**).
4. Loosen the black wire connector (on the end of the long black wire) at the headlight diode assembly just enough to maintain the connection and yet expose part of the metal terminal in the connector. Place black (–) probe on the connector (**Figure 11-48, Page 11-43**). **See following CAUTION.**

▲ CAUTION

- Before connecting battery cables, make sure no electrical components touch the front body trim or other parts of the vehicle frame. Place a dry towel between the body trim and the center dash to prevent an electrical short circuit.
5. Connect the battery, positive cable first.
 6. Pull the light switch to the ON position. The reading should be 11-12 volts. If there is no voltage reading, check continuity of the 16 gauge black wire from the headlight to the headlight diode. Check continuity of the 16 gauge black wire from headlight diode to the vehicle frame. If the wires show continuity and the readings are still incorrect, replace the headlight diode. **See Headlight Diode Removal, Section 12, Page 12-30.**
 7. With the Forward/Reverse handle in the NEUTRAL position and the wheels chocked, start the engine and depress the accelerator pedal to the floor.
 8. Push the light switch to the OFF position. The reading should be 14.7-15.3 volts.
 9. Pull the light switch to the ON position. The reading should be 11-13 volts. If the reading does not drop from 14.5-15.5 volts to 11-13 volts, replace the headlight diode.

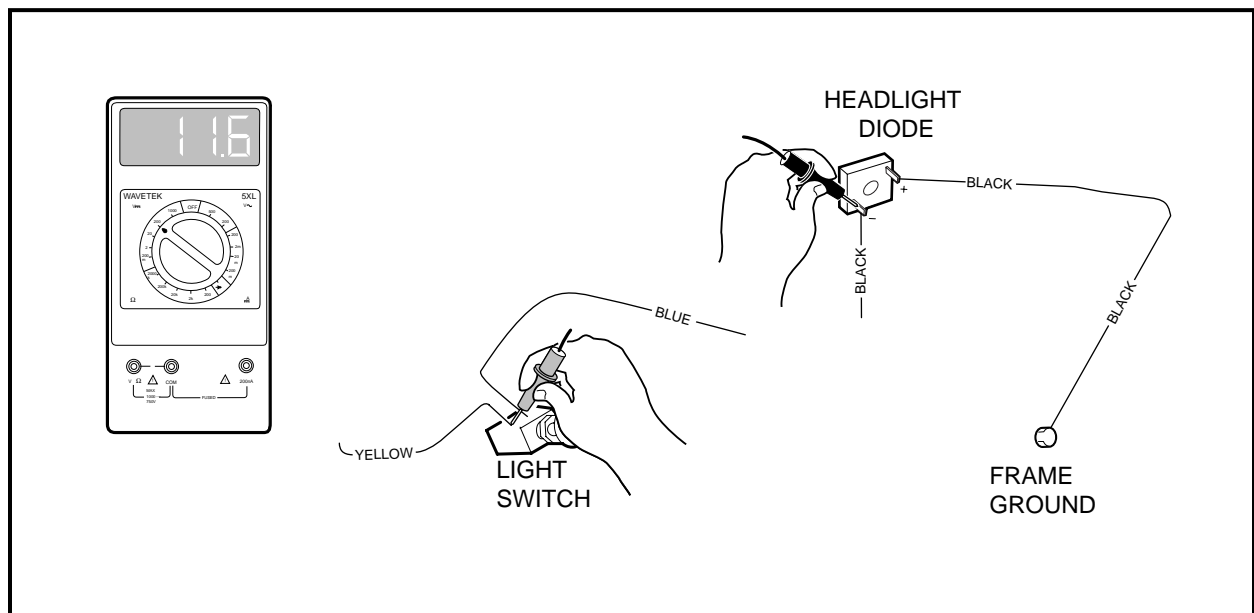

Figure 11-48 Headlight Diode Circuit Test

TEST PROCEDURE 30 – VOLTAGE AT HEADLIGHT SOCKET

Read **DANGER** and **WARNING** on page 11-1.

NOTE: Keep the battery connected while performing this test procedure.

1. Place the Forward/Reverse handle in the NEUTRAL position, and chock the wheels.
2. Inspect wires at the light bulb socket. Make sure wires are securely fastened to the contacts inside socket.

3. Remove the wiring harness from the headlight (**Figure 11-49, Page 11-44**).
4. Using a multimeter set to 20 volts DC, place the black (-) probe of multimeter into the black wire terminal of the wiring harness. Place the red (+) probe into the blue wire terminal.
5. Pull the light switch to the ON position. If the multimeter reads approximately 12 volts, replace the headlight bulb.
6. If there is no voltage reading at the wiring harness, check continuity of the 16 gauge blue wire from the headlight to the light switch. Using a multimeter set to 20 volts DC, attach using an alligator clip, the black (-) probe of multimeter onto the negative battery terminal and place the red (+) probe into the blue wire terminal of the wiring harness. If the multimeter reading is approximately 12 volts, the blue wire has continuity.
7. Check continuity of the 16 gauge black wire from the headlight to the ground terminal. Using a multimeter set to 20 volts DC, place the black (-) probe of multimeter into the black wire terminal of the wiring harness and attach using an alligator clip, the red (+) probe onto the positive battery terminal. If the multimeter reading is approximately 12 volts, the black wire has continuity.

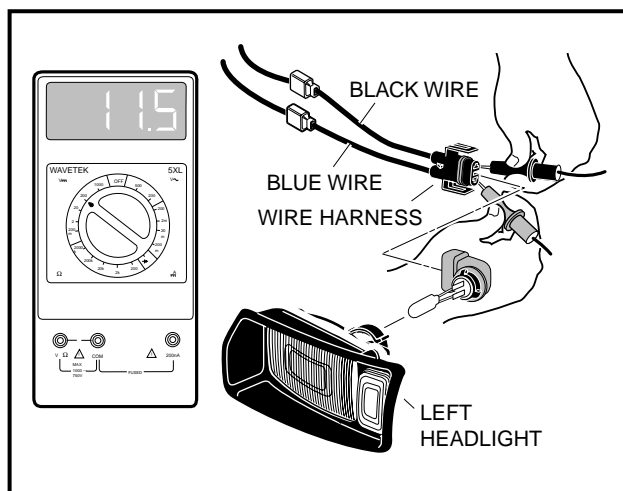

Figure 11-49 Check Voltage to Headlight Socket

SECTION 12 – ELECTRICAL COMPONENTS

⚠ DANGER

- **Battery – Explosive gases! Do not smoke. Keep sparks and flames away from the vehicle and service area. Ventilate when charging or using in an enclosed space. Wear a full face shield and rubber gloves when working on or near batteries.**
- **Battery – Poison! Contains acid! Causes severe burns. Avoid contact with skin, eyes or clothing. Antidotes:**
 - **External: Flush with water. Call a physician immediately.**
 - **Internal: Drink large quantities of water. Follow with milk of magnesia or vegetable oil. Call a physician immediately.**
 - **Eyes: Flush with water for 15 minutes. Call a physician immediately.**
- **Gasoline – Flammable! Explosive! Do not smoke. Keep sparks and flames away from vehicle and service area. Service only in a well-ventilated area.**
- **Do not operate vehicle in an enclosed area without proper ventilation. The engine produces carbon monoxide, which is an odorless, deadly poison.**
- **Use caution when working under bed. Be sure prop rod is secure; otherwise the bed will fall, resulting in severe personal injury or death.**

⚠ WARNING

- **Only trained technicians should repair or service this vehicle. Anyone doing even simple repairs or service should have knowledge and experience in electrical and mechanical repair.**
- **Follow the procedures exactly as stated in this manual, and heed all DANGER, WARNING, and CAUTION statements in this manual as well as those affixed to the vehicle.**
- **Wear safety glasses or approved eye protection while servicing vehicle.**
- **Turn key switch OFF, place Forward/Reverse handle in the NEUTRAL position, and remove key before servicing the vehicle.**
- **Moving parts! Do not attempt to service the vehicle while it is running.**
- **Use insulated tools when working near batteries or electrical connections. Use extreme caution to avoid shorting of components or wiring.**
- **Frame ground – Do not allow tools or other metal objects to contact frame when disconnecting battery cables or any other electric wiring. Never allow a positive wire to touch the vehicle frame, engine, or any other metal component.**
- **Hot! Do not attempt to service hot engine or exhaust. Can cause severe burns. Allow engine and exhaust to cool prior to servicing.**
- **If wires are removed or replaced, make sure wiring is properly routed and secured to vehicle frame. Failure to properly route and secure wiring could result in vehicle malfunction, property damage or personal injury.**

WARNING CONTINUED ON NEXT PAGE...

- To avoid unintentionally starting the vehicle:
 - Disconnect battery cables, negative cable (–) first (Figure 12-1, Page 12-2).
 - Disconnect the spark plug wire from the spark plug.
- Do not disengage prop rod until all persons are clear of cargo bed area. Do not drop tilt bed; lower gently and keep entire body clear. Failure to follow these instructions could result in severe injury.
- Lift only one end of the vehicle at a time. Before lifting, set the park brake when lifting the front of the vehicle, unload the cargo bed and chock the wheels that remain on the floor. Use a suitable lifting device (chain hoist or hydraulic floor jack) with 1000 lb. (454 kg) minimum lifting capacity. Do not use lifting device to hold vehicle in raised position. Use approved jack stands of proper weight capacity to support the vehicle.

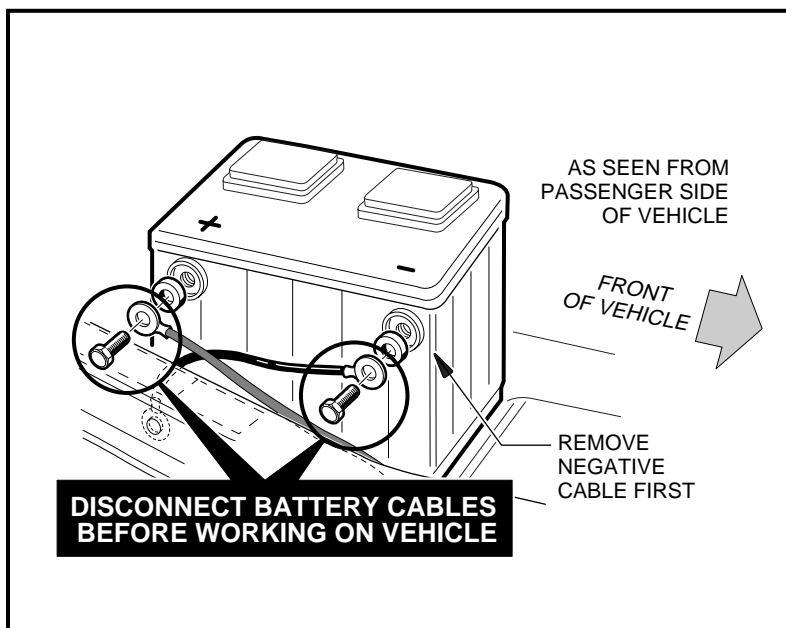

Figure 12-1 Battery Disconnect

STARTER/GENERATOR

Read **DANGER** and **WARNING** on page 12-1.

Testing the Starter/Generator

See Section 11, Test Procedure 8, Page 11-29, and Test Procedure 11, Page 11-31.

Starter/Generator Removal

1. Access the engine compartment. See **DANGER** on page 12-1.
 - 1.1. Tilt the bed and ensure that the prop rod is engaged.
2. Disconnect the battery cables, negative cable (–) first (Figure 12-1, Page 12-2).
3. Disconnect the wires from the starter/generator (1). Mark wires before disconnecting. Loosen the pivot nuts (7) and bolts (5) (Figure 12-2, Page 12-3).

4. Remove the mounting/adjustment nut (12), washer (9) and bolt (11). Lower the starter/generator and slip the belt (4) off the pulley (10).
5. Support the starter/generator so that when the pivot bolts are removed the starter/generator will not fall to the ground. Remove the two pivot nuts (7) and bolts (5) from the mounting bracket.
6. Remove the starter/generator.

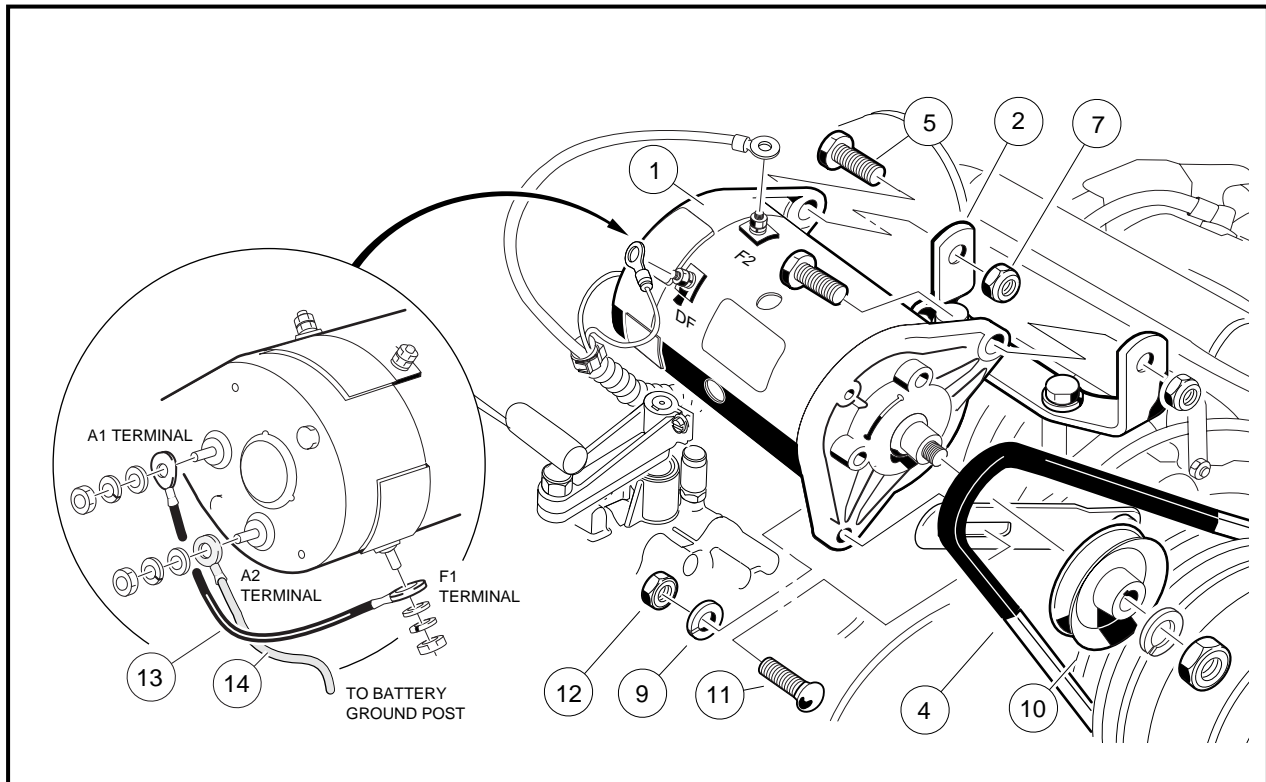

Figure 12-2 Starter/Generator Removal

Disassembly of the Starter/Generator to Service the Brushes

1. Remove the two bolts (20) and pull commutator end cover (23) free of starter/generator housing (24) (Figure 12-3, Page 12-4). See following NOTE.

NOTE: If the brushes are not removed, contact between the brushes and commutator as the commutator end cover is being removed or installed could damage the brushes. Lift the brush springs out of the notches in the brushes and pull the brushes back from the center of the commutator end cover. The springs will rest on the sides of the brushes and help prevent them from sliding towards the center of the cover (Figure 12-7, Page 12-5).

2. Remove brush covers (29 and 30), screws (25) and lockwashers (26), brush springs (28), and brushes (27) (Figure 12-4, Page 12-4). See following NOTE.

NOTE: To clean and inspect the armature/commutator and the bearings, See **Disassembly of the Starter/Generator to Service the Armature/Commutator** on page 12-6.

Brush Inspection and Replacement

1. Visually inspect brushes. Replace brushes that are cracked or severely chipped.
2. Check the wear line on the side of the brush. If the end of the brush is within 1/16 of an inch (1.6 mm) of the wear line, replace all four brushes (Figure 12-5, Page 12-4).

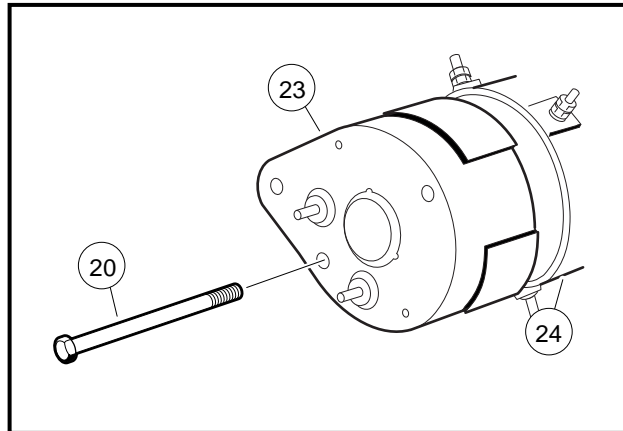

Figure 12-3 Commutator End Cover

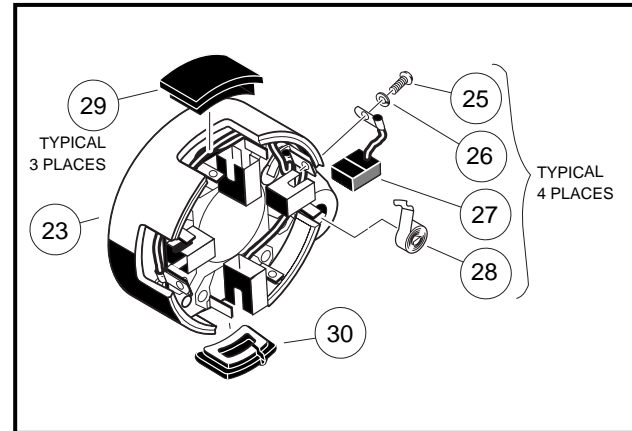

Figure 12-4 Brush Covers and Brushes

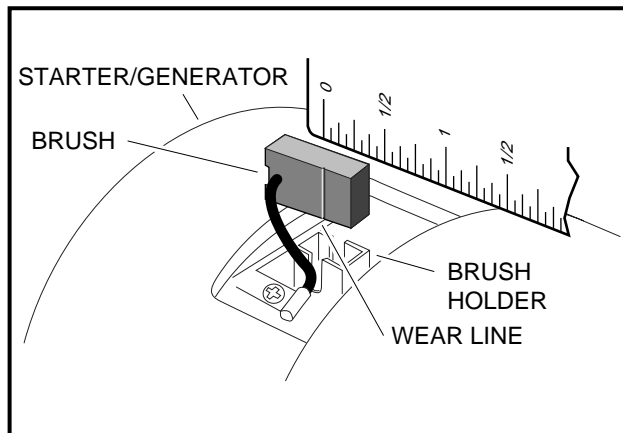

Figure 12-5 Inspect Brushes

Brush Spring Inspection and Replacement

1. Visually inspect springs. Replace all four springs if any spring is discolored from heat (straw or bluish in color).
2. Install the four brushes (27) into their holders and insert the four brush springs (28) (Figure 12-4, Page 12-4). Using a spring scale, test brush spring tension. If any spring has a tension less than 24 ounces, replace all four springs (Figure 12-6, Page 12-5). See following CAUTION.

⚠ CAUTION

- When checking brush spring tension, do not push springs beyond the point they would normally be if there were new brushes installed. Exerting excessive force or pushing brush springs beyond their normal maximum extension point will damage springs.

Starter/Generator Assembly

1. Connect the brush wires to the holders using four lockwashers (26) and four screws (25), making sure the crossover leads are connected also. Tighten the screws to 31 in-lb (3.5 N·m) (Figure 12-4, Page 12-4).

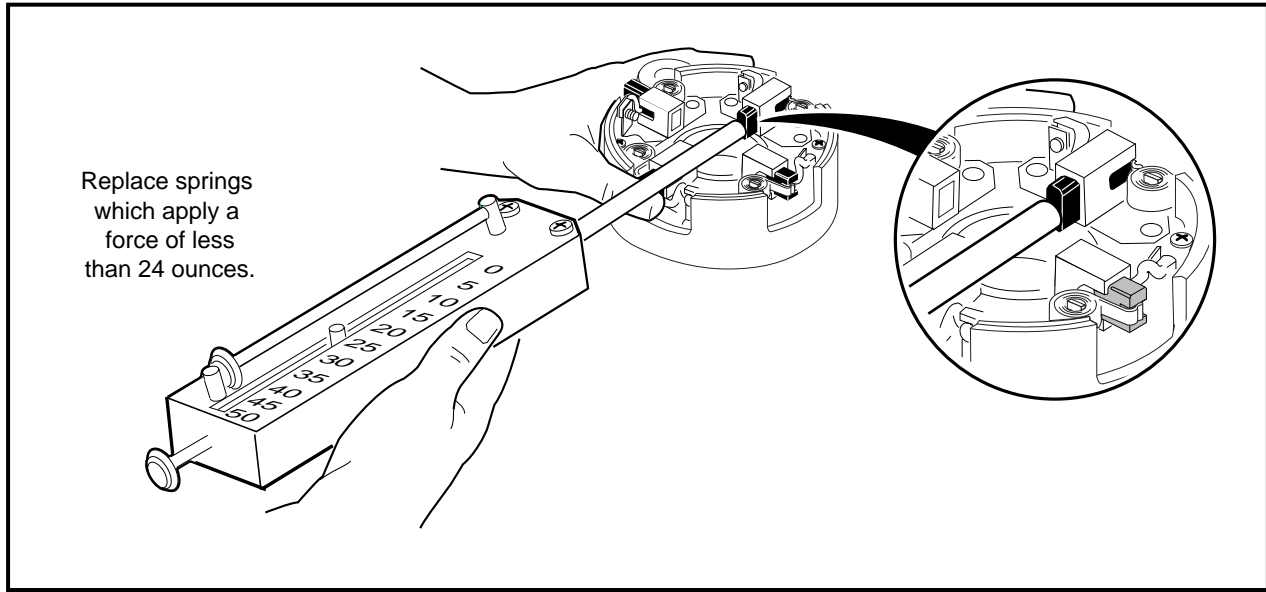

Figure 12-6 Brush Spring Tension Test

2. To prevent contact between the brushes and commutator as the commutator is installed, and possible damage to the brushes, lift the brush springs out of the notches in the brushes and pull the brushes back from the center of the commutator end cover. The springs will rest on the sides of the brushes and help prevent them from sliding towards the center of the cover (**Figure 12-7, Page 12-5**).
3. Install the commutator end cover (23) onto the armature shaft. Align the locating pin with the pin hole in the cover. Install two M6 x 180 mm bolts (20) and tighten to 100 in-lb (11.3 N-m) (**Figure 12-3, Page 12-4**).
4. Push the brushes down into the holders. Position springs into the notches in the brushes. Install the brush cover (30) that has the drain hole in it next to the A2 terminal. Install the remaining three brush covers (29) in the openings in the commutator end cover (23) (**Figure 12-4, Page 12-4**).

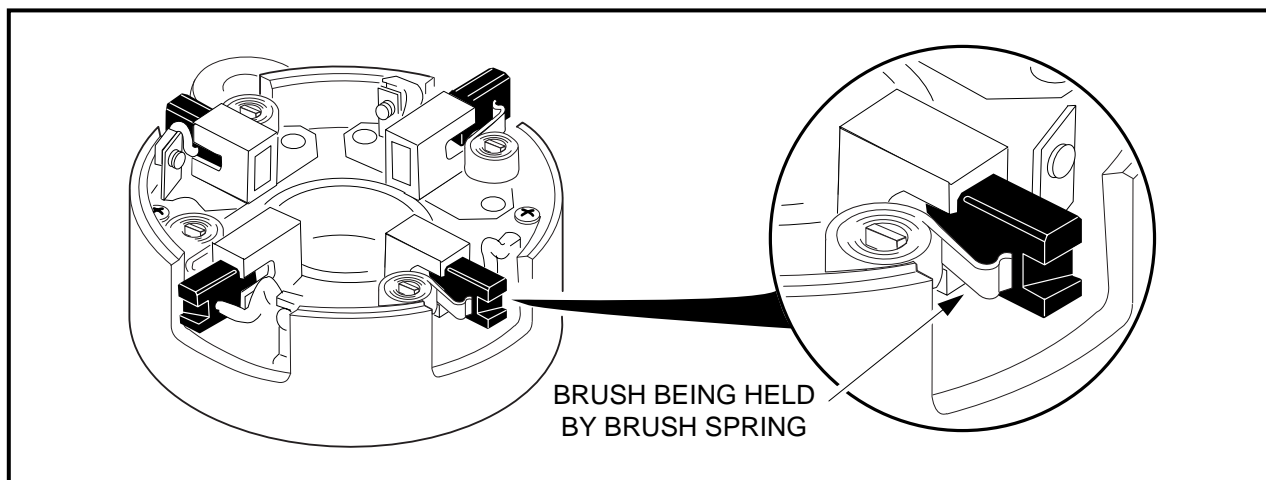

Figure 12-7 Pull Brushes Away From Center of the Commutator End Cover

Disassembly of the Starter/Generator to Service the Armature/Commutator

1. If the brushes are not removed, contact between the brushes and commutator as the commutator end cover is being removed or installed could damage the brushes.
 - 1.1. Lift the brush springs out of the notches in the brushes and pull the brushes back from the center of the commutator end cover. The springs will rest on the sides of the brushes and help prevent them from sliding towards the center of the cover (**Figure 12-7, Page 12-5**).
2. Remove the two bolts (20), and pull commutator end cover (23) free of the starter/generator housing (24) (**Figure 12-3, Page 12-4**).
3. To separate armature (33) from output end cover (36), remove nut (41), lockwasher (40), pulley (39), shaft key (34), spacer (37), and bearing retainer screws (43) (**Figure 12-8, Page 12-6**).

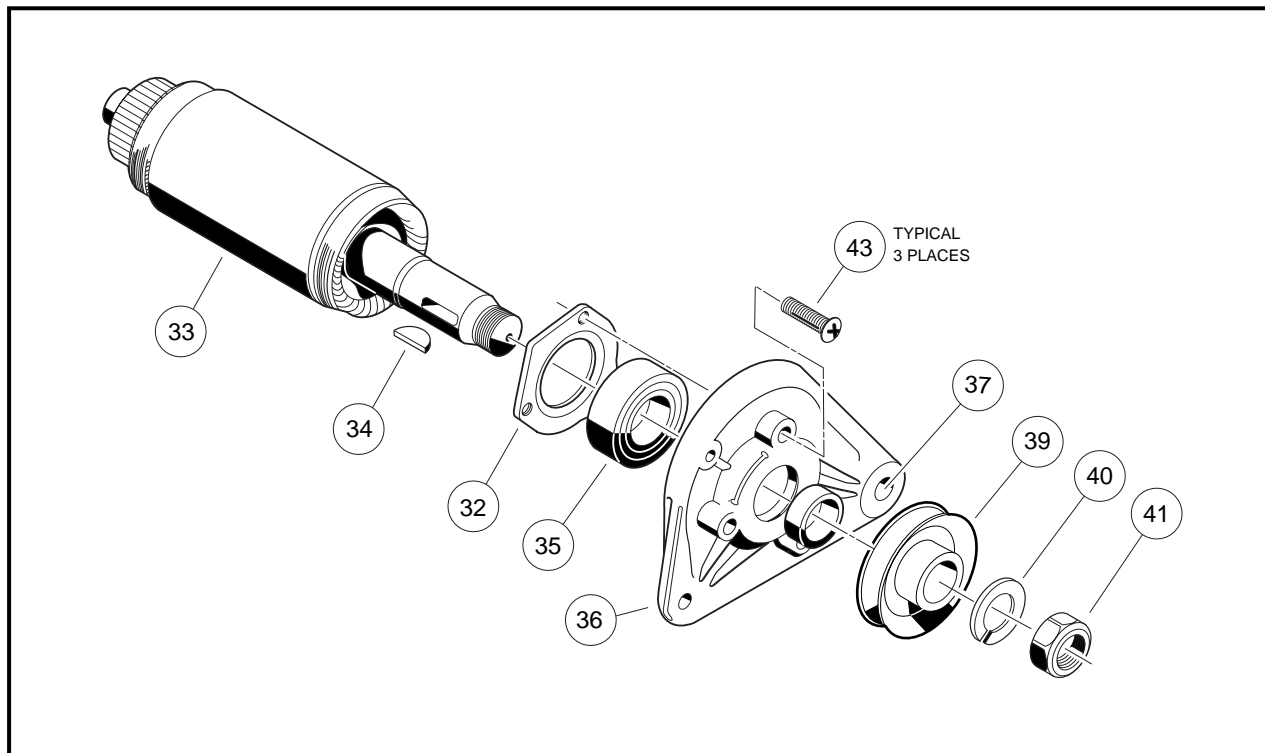

Figure 12-8 Armature and Output End Cover Assembly

Bearing Cleaning and Inspection

1. Using a clean cloth, wipe the carbon dust from the two bearings. Inspect bearings by spinning them by hand and checking for both axial (A) and radial (B) play (**Figure 12-9, Page 12-7**).
2. Replace the bearing if it is noisy, does not spin smoothly, or has excessive play. Check the bearings and replace if rusted, worn, cracked, or if there is an abnormal color change in the metal of the bearing. Bearings should be replaced if there is extensive wear or pitting on the balls or on the rolling surfaces. Do not remove the bearings unless they are to be replaced.

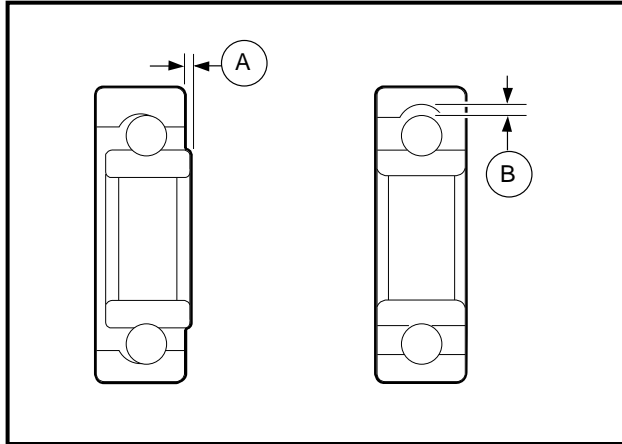

Figure 12-9 Bearing Play Inspection

Bearing Removal

1. Place the wedge attachment tool (CCI 1012812) between the bearing and the armature. Make sure the wedge attachment tool is supporting the inner race of the bearing. If a press is not available, secure a bearing puller (CCI 1012811) to the wedge attachment tool and pull the bearing off of the end of the armature shaft. Support the armature so that it will not drop when the bearing is removed (**Figure 12-10, Page 12-7**).
2. Discard the bearings.
3. Slide the bearing retainer (32) off of the output end of the shaft (**Figure 12-8, Page 12-6**).

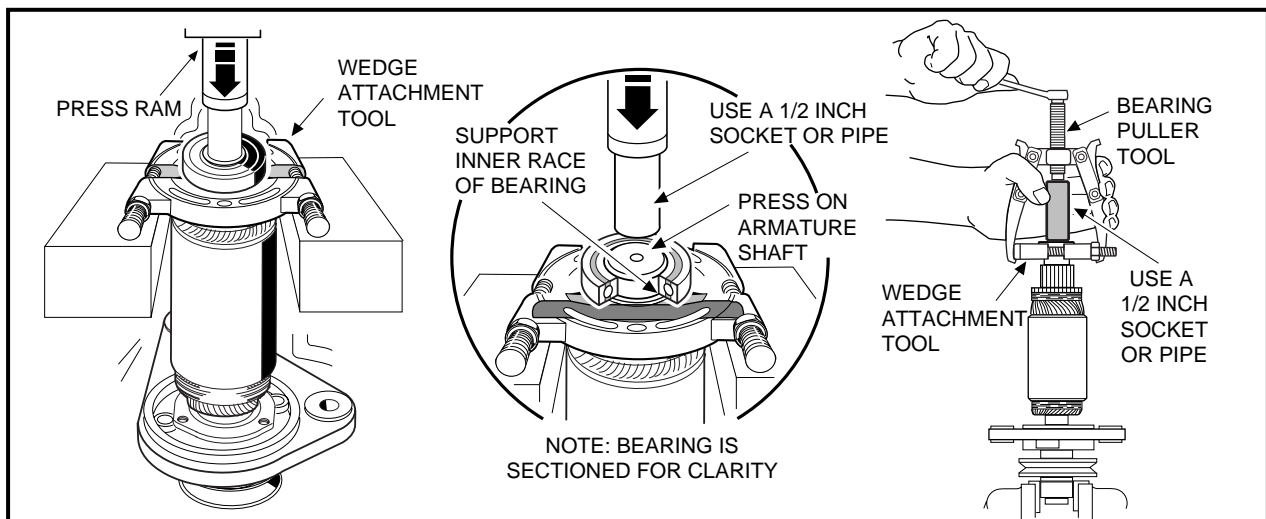

Figure 12-10 Bearing Removal

Field Coil Removal

1. Remove the retaining nut from each field coil terminal and slide the insulator out of the slots in the housing. Remove the four pole piece screws from the housing. Remove the four pole pieces from inside the housing. Remove the field coils from the inside of the housing (**Figure 12-11, Page 12-8**).
See following NOTE.

Field Coil Removal, Continued:

NOTE: Do not remove the insulators or the field coils unless an electrical test indicates that it is necessary (Figure 12-11, Page 12-8). See Test Procedure 8, Section 11, Page 11-29.

Visual Inspection of Armature

Obvious defects can be seen by examining the armature. If an armature has frayed or charred insulation, broken wires or thrown solder, it is obvious without testing that it should be replaced. Faults seen during the visual inspection can aid in diagnosing the original cause of the failure. Items to look for are listed below.

- Burned, charred, or cracked insulation
- Improperly cured varnish
- Thrown solder
- Flared armature windings
- Worn, burned, or glazed commutator
- Loose or raised commutator bars
- Bruised or damaged armature core laminations
- Worn armature bearing or shaft
- Dirty or oily commutator

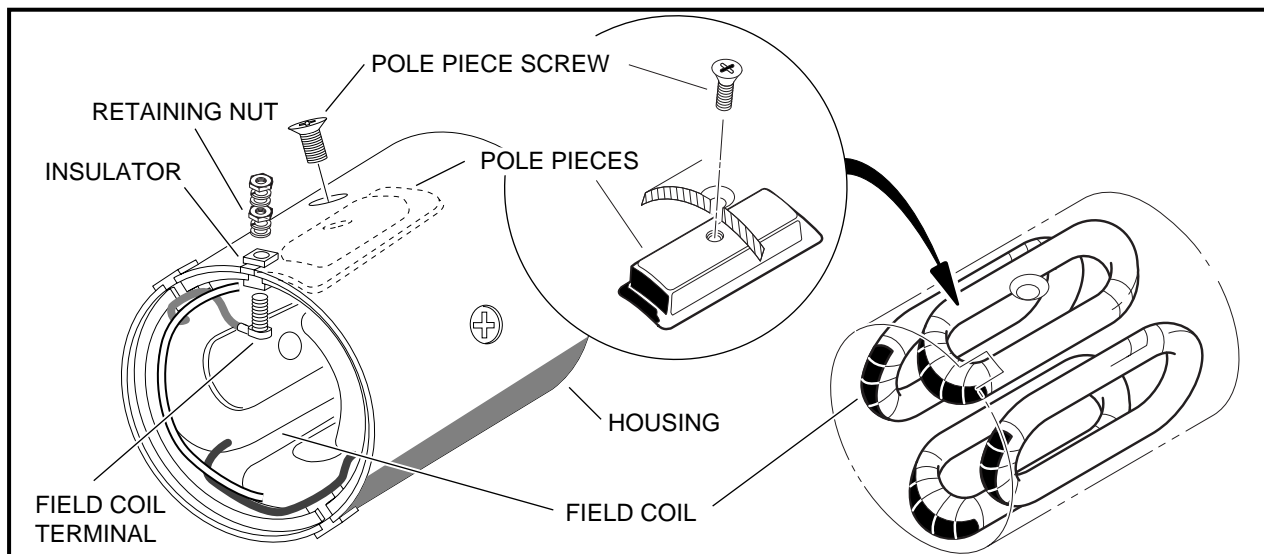

Figure 12-11 Field Coil Assembly

Commutator Cleaning and Inspection

1. Clean the carbon dust, dirt and oil from the commutator. Visually inspect the commutator for worn, burned or glazed areas. Check for loose or raised commutator bars. Slight roughness of the commutator can be polished away with 400 grit (or finer) sandpaper. **See following CAUTION.**

⚠ CAUTION

- Never use emery cloth on the commutator. Particles of emery are conductive and may short-circuit the commutator bars. Never use oil or lubricants on the commutator or brushes.
2. Using a micrometer, measure the outside diameter at two points along the commutator. If the commutator outside diameter is less than 1.535 inches (39 mm), replace the armature and bearings (**Figure 12-12, Page 12-9**).

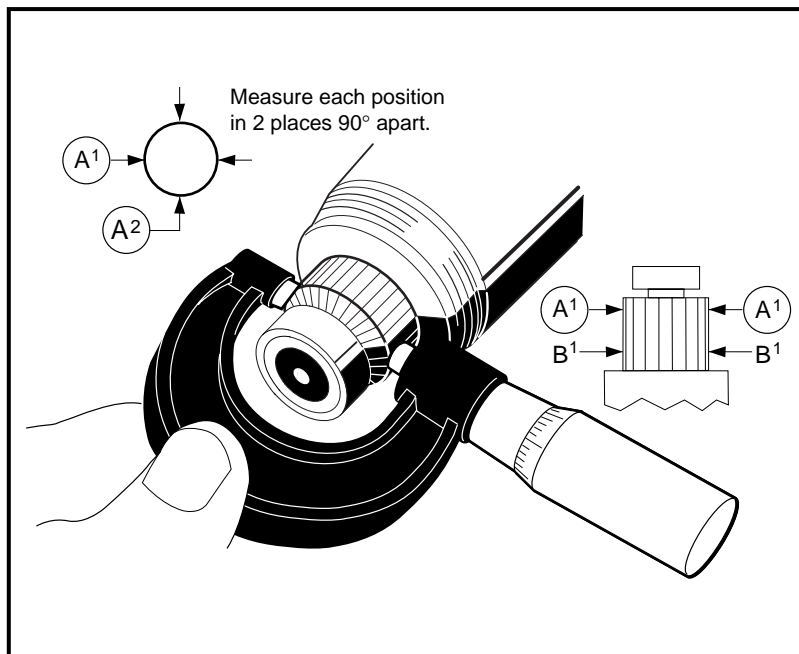

Figure 12-12 Inspect Commutator

Armature Ground Test

⚠ CAUTION

- Do not submerge armature in solvent.

NOTE: Before testing, wipe the armature with a clean cloth and remove carbon dust and metal particles from between commutator bars.

1. Using a multimeter set on 200 Ω (ohms), place the positive probe on the commutator bars and the negative probe on the armature core. The reading should be **NO** continuity. If the reading is incorrect, replace the armature and the two bearings (**Figure 12-13, Page 12-10**).

Visual Inspection of Field Coils

If the insulation on the field coils appears blackened or charred, the serviceability of the coils is questionable. Burned or scorched coil insulation indicates the starter/generator has overheated due to overloads or grounded or shorted coil windings. Be sure the insulators are tight in the housing.

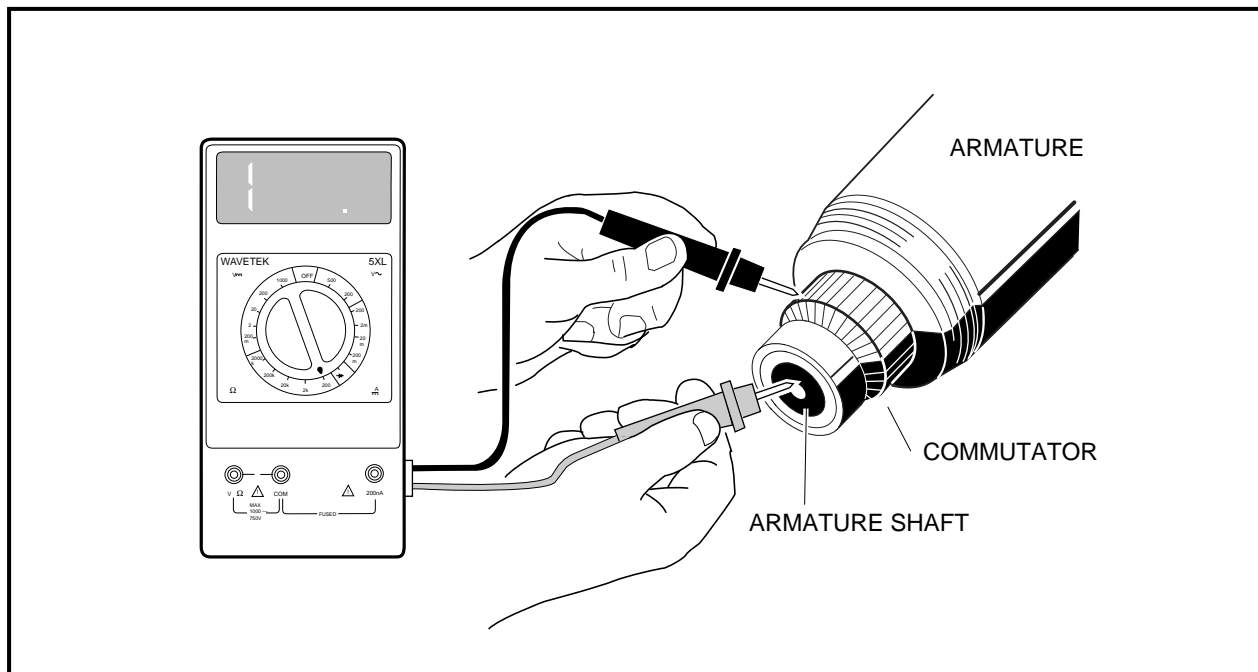

Figure 12-13 Armature Ground Test

Starter/Generator Rework

Any rework must be performed by a qualified technician. Starter/Generator service specifications are listed in the following table.

ITEM	SERVICE LIMIT
Commutator diameter (minimum)	1.535 inches (39 mm)
Concentric with armature shaft within	0.002 inch (0.051 mm)
Limit depth of cut when machining commutator	0.007 inch (0.2 mm)
If under cut of segment insulator is less than 0.016 inch (0.406 mm), then it should be undercut to	0.031 inch (0.8 mm)
Dielectric strength	500 VAC for one minute
Armature insulation resistance	0.2M Ω (ohms) at 500 VDC
Starter field coil resistance	0.006-0.01 Ω (ohms)
Generator field coil resistance	4.5-5.5 Ω (ohms)

Starter/Generator Assembly

1. Place the field coil into the housing. The two insulators that look alike fit into the slots next to the F1 and F2 markings on the outside of the housing. The insulator that looks different slides into the slot next to the DF marking.
2. After the insulators are seated in the slots, install the threaded terminals through the wire connectors and then through the insulators. Install a flat washer, lockwasher and nut onto each threaded terminal on the outside of the housing. Tighten nuts to 47.5 in-lb (5.4 N-m) (Figure 12-11, Page 12-8).

▲ CAUTION

- *Route the field terminal wires so that they will not contact the armature.*
3. Install the four pole pieces into the housing. Use the four screws to secure pole pieces to the inside of the housing to retain the field wires. Tighten screws to 9 ft-lb (12.2 N·m) **(Figure 12-11, Page 12-8)**.
 4. Slide the bearing retainer onto the output end of the armature shaft (33) so that it will hold the outside of the bearing (35) only.
 5. Press a new ball bearing (35) onto the output end of the armature **(Figure 12-8, Page 12-6)**. Press a new ball bearing onto the commutator end of the armature shaft. **See following CAUTION.**

▲ CAUTION

- *To prevent damage to the retainer, use care while pressing new bearing onto the output end of the shaft.*
 - *Press against the inner race of the new bearing until it is fully seated.*
6. Install the output end cover (36) onto the armature. Secure the bearing retainer (32) to the cover and tighten the screws (43) to 39 in-lb (4.4 N·m) **(Figure 12-8, Page 12-6)**.
 7. Slide the housing with field coils over the armature. Use the locating pin to align housing to the cover.

NOTE: The terminal insulators should be on the commutator end of the housing.

8. To prevent contact between the brushes and commutator as the commutator cover is installed, and possible damage to the brushes, lift the brush springs out of the notches in the brushes and pull the brushes back from the center of the commutator end cover. The springs will rest on the sides of the brushes and help prevent them from sliding towards the center of the cover **(Figure 12-7, Page 12-5)**.
9. Install the commutator end cover (23) onto the armature shaft. Align the locating pin with the pin hole in the cover. Install the two M6 x 180 mm bolts (20) and tighten to 100 in-lb (11.3 N·m) **(Figure 12-3, Page 12-4)**.
10. Push the brushes down into the holders. Place springs into the notches in the brushes. Install the brush cover (30) that has the drain hole in it next to the A2 terminal. Install the remaining three brush covers (29) in the openings in the commutator end cover (23) **(Figure 12-4, Page 12-4)**.
11. Slide the spacer (37) onto the end of the shaft. Insert the shaft key (34) into the shaft. Install the belt pulley (39) onto the shaft, and install the lockwasher (40) and M14 nut (41). Tighten the nut to 28 ft-lb (38 N·m) **(Figure 12-8, Page 12-6)**.

Starter/Generator Installation

1. Install the green wire from the F1 terminal to the A1 terminal on the starter/generator **(Figure 12-2, Page 12-3)**. Install a flat washer, lockwasher, and nut onto each terminal and tighten to 48 in-lb (5.4 N·m).
2. Install two 3/8 hex head pivot bolts (5) into the mounting bracket with the heads of the bolts facing towards the driver side of the vehicle. Position the starter/generator in the mounting bracket so that the bolts will go through the starter/generator before going through the bracket. Install a locknut (7) onto each bolt. Tighten to finger tight **(Figure 12-14, Page 12-12)**.

Starter/Generator Installation, Continued:

3. Install the adjustment bolt (11) through the adjusting bracket (4) and then through the starter/generator. Install a lockwasher (9) and 5/16 nut (12) onto the end of the adjustment bolt (11). Tighten to finger tight (**Figure 12-14, Page 12-12**).
4. Install the belt (3), then tighten the mounting bolts. **See Belt Tension Adjustment on page 12-12.**
5. Connect the yellow wire from the voltage regulator to the DF terminal on the starter/generator. Install a flat washer, lockwasher, and nut onto the terminal. Tighten the nut to 31 in-lb (3.5 N·m).
6. Install the white wire from the solenoid to the F2 terminal on the starter/generator. Install the black wire from the frame to the A2 terminal on the starter/generator. Install a flat washer, lock washer and nut onto each terminal, and tighten the nut to 48 in-lb (5.4 N·m).
7. Connect battery cables, positive cable first and tighten the terminals to 20 ft-lb (27.1 N·m). Coat terminals with Battery Protector Spray (CCI 1014305).

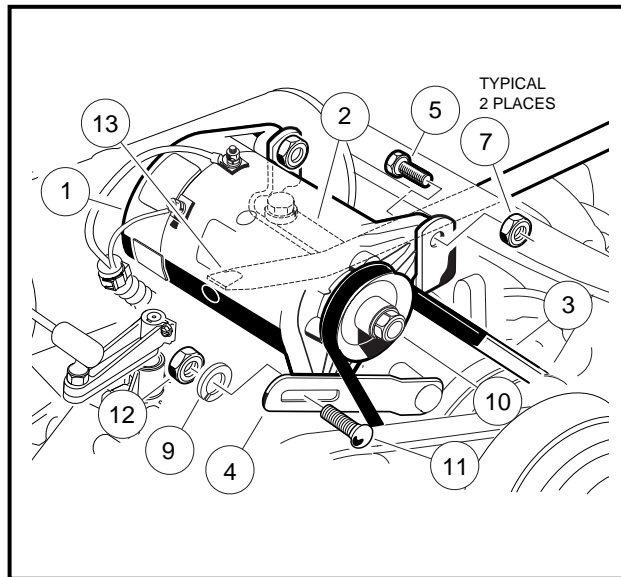

Figure 12-14 Starter/Generator Installation

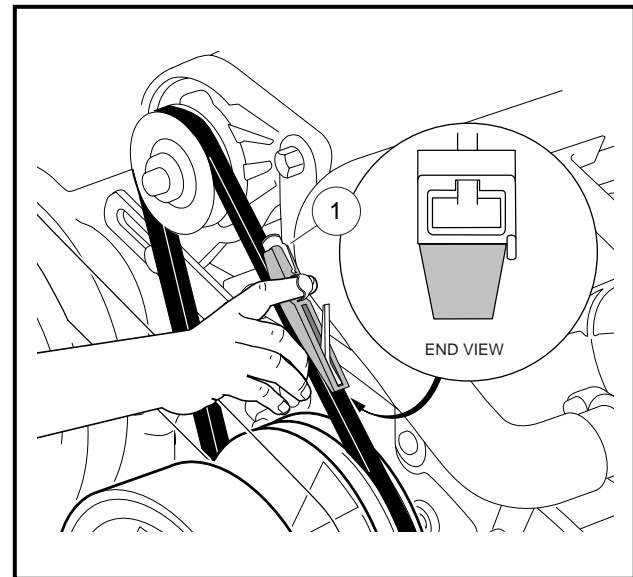

Figure 12-15 Belt Tension Gauge

Belt Tension Adjustment

Belt tension should be checked periodically. If the belt slips when starter/generator motor operates, adjust belt to correct tension.

1. Place the Forward/Reverse handle in NEUTRAL, chock the wheels and disconnect the battery cables, negative cable (-) first (**Figure 12-1, Page 12-2**).
2. Access the engine compartment. **See DANGER on page 12-1.**
 - 2.1. Tilt the bed and ensure that the prop rod is engaged.
3. Make sure the two pivot bolts (5) on the mounting bracket are finger tight. The carriage bolt (11) and hex nut (12) are to be finger tight also (**Figure 12-14, Page 12-12**).
4. Push the starter/generator down so it is at the lowest point of its adjustment travel. With the starter/generator belt fully in place around the drive clutch pulley, install the starter/generator belt (3) around the pulley (10) on the end of the starter/generator.

5. Position a pry bar (13) between the top of the starter/generator mounting bracket (2) and the underside of the starter/generator by passing the pry bar under the exhaust header.
6. While holding the pry bar, measure the belt tension using a Krikit[®] gauge (1) (available at NAPA[®] Auto Parts stores), or equivalent. Proper tension for a new starter/generator belt should be 75 ft-lb (101.7 N-m) or for an existing belt, 45 ft-lb (61 N-m) (**Figure 12-15, Page 12-12**).
7. While maintaining the tension, tighten the adjustment nut (12) to 12 ft-lb (16.3 N-m). Tighten the two pivot bolts (5) and hex nuts (7) to 23 ft-lb (31.2 N-m) (**Figure 12-14, Page 12-12**). **See following CAUTION.**

▲ CAUTION

- Remove pry bar before starting engine.
8. Connect battery cables, positive cable first and tighten the terminals to 20 ft-lb (27.1 N-m). Coat terminals with Battery Protector Spray (CCI 1014305).

VOLTAGE REGULATOR

Read **DANGER** and **WARNING** on page 12-1.

Testing the Voltage Regulator

See Test Procedure 12, Section 11, Page 11-32.

Voltage Regulator Removal

1. Disconnect the battery cables, negative cable (–) first (**Figure 12-1, Page 12-2**).
2. Remove the electrical component box cover.
3. Disconnect the voltage regulator red wire (1) at the large post on the solenoid, the yellow wire (4) at the bullet connector, and the black wire (7) from the wire harness and at the battery frame ground (**Figure 12-16, Page 12-13**).
4. Remove the voltage regulator mounting screw (8) and remove the voltage regulator (9).

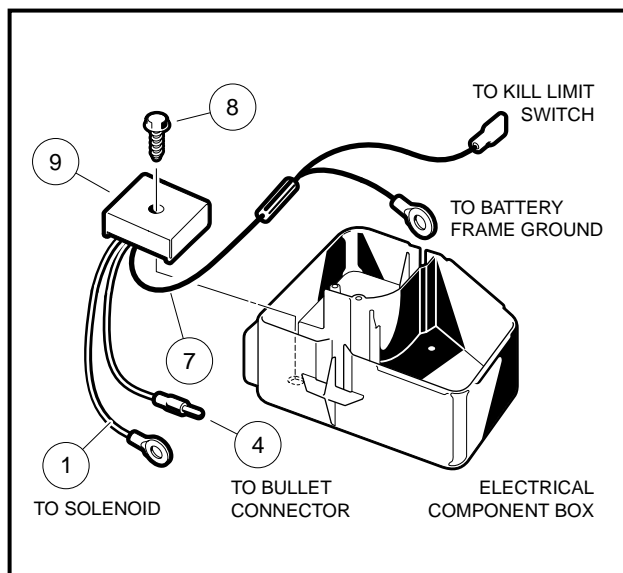

Figure 12-16 Voltage Regulator

Voltage Regulator Installation

1. Position the voltage regulator (9) in the electrical component box and install the mounting screw (8) (**Figure 12-16, Page 12-13**). Tighten screw to 23 in-lb (2.6 N·m).
2. Connect the voltage regulator red wire (1) at the large post on the solenoid with the other red wires, the yellow wire (4) at the bullet connector, and the black wire (7) to the wire harness and the battery frame ground (**Figure 12-16, Page 12-13**).
3. Install snap-on electrical component box cover. Be sure to firmly press down all corners. Install screw and tighten to 18 in-lb (2 N·m).
4. Connect battery cables, positive cable first and tighten terminals to 20 ft-lb (27.1 N·m). Coat terminals with Battery Protector Spray (CCI 1014305).
5. Place Forward/Reverse handle in the NEUTRAL position. Start the engine and check regulator for proper functioning as described in the voltage regulator test procedure. **See Test Procedure 12, Section 11, Page 11-32.**

DIODE

Read **DANGER** and **WARNING** on page 12-1.

Testing the Diode

See Test Procedure 10, Section 11, Page 11-30.

Diode Removal

1. Disconnect the battery cables, negative cable (–) first (**Figure 12-1, Page 12-2**).
2. Disconnect wires from the diode (1) (**Figure 12-17, Page 12-14**).
3. Remove the mounting hardware (2) from the diode and remove it from the vehicle.

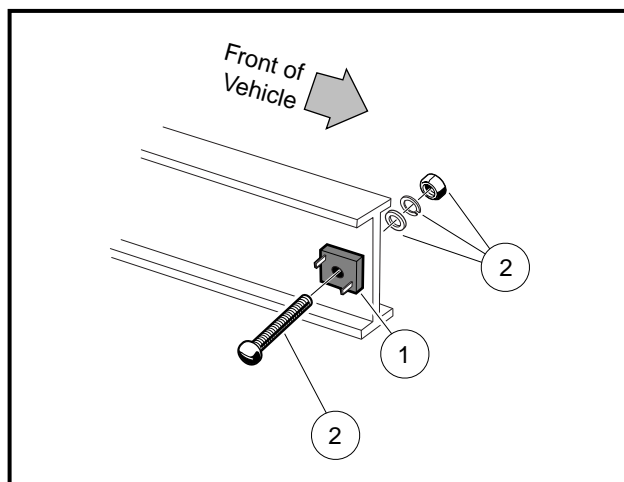

Figure 12-17 Diode

Diode Installation

1. Mount the diode to the frame using the mounting hardware. Tighten to 25 in-lb (2.8 N·m) (**Figure 12-17, Page 12-14**).
2. Connect the white 12 gauge wire from the harness to the negative (–) terminal on the diode. Connect the red 12 gauge wire from the wire harness to the positive (+) terminal on the diode. **See following WARNING.**

▲ WARNING

- **Incorrect wiring could result in severe injury or death.**
 - **Diode and solenoid connections must have correct polarity.**
 - **Keep all persons clear of engine belts when making final connections.**
3. Connect battery cables, positive cable first and tighten the terminals to 20 ft-lb (27.1 N·m). Coat terminals with Battery Protector Spray (CCI 1014305).

KEY SWITCH

Read **DANGER** and **WARNING** on page 12-1.

Testing the Key Switch

See Section 11, Test Procedure 4, Page 11-26, and Test Procedure 17, Page 11-36.

Key Switch Removal

1. Disconnect the battery cables, negative cable (–) first (**Figure 12-1, Page 12-2**).
2. Remove the dash panel.
 - 2.1. Loosen seven Tuflok screws, but do not remove screws completely, as shown in detail 1 (**Figure 12-19, Page 12-16**).
 - 2.2. Remove Tuflok screws from dash panel as shown in detail 2.
 - 2.3. Pull forward on top of dash panel to access back side of key switch. There is sufficient slack in wiring to allow for this as shown in detail 3.
3. Disconnect the wire connector from the key switch.
4. Remove the key switch:
 - 4.1. Remove the key switch nut (1) (**Figure 12-18, Page 12-15**).
 - 4.2. Remove key switch (2) from back side of dash panel.

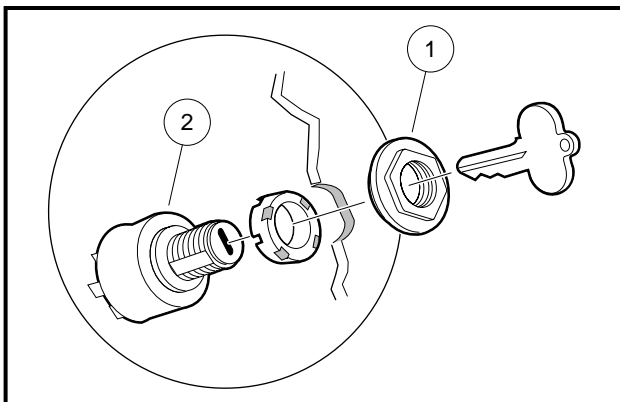

Figure 12-18 Key Switch Removal

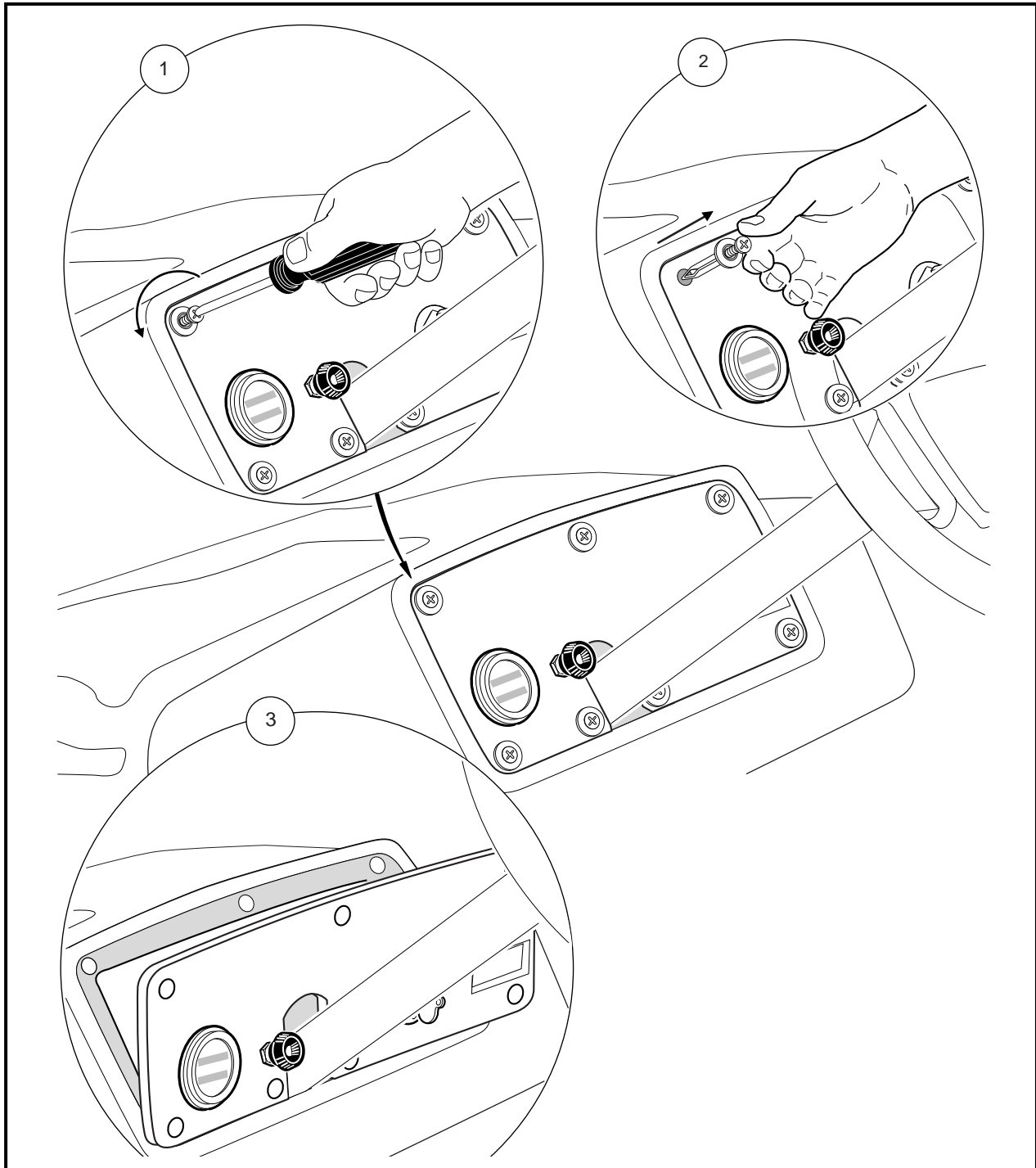

Figure 12-19 Center Dash Panel Removal

Key Switch Installation

1. Reverse removal procedures to install key switch in the dash. Tighten the key switch nut firmly. Reconnect the wire connector to the key switch.
2. Install the dash panel.
3. Connect battery cables, positive cable first and tighten the terminals to 20 ft-lb (27.1 N·m). Coat terminals with Battery Protector Spray (CCI 1014305).

SOLENOID

Read **DANGER** and **WARNING** on page 12-1.

Testing the Solenoid

See Test Procedure 6, Section 11, Page 11-27.

Solenoid Removal

1. Disconnect the battery cables, negative cable (–) first (**Figure 12-1, Page 12-2**).
2. Remove electrical component box cover.
3. Disconnect all the wires from the solenoid.
4. Remove the two screws securing the solenoid in place.
5. Remove the solenoid.

Solenoid Installation

1. Install the solenoid in the electrical component box. Use two screws to secure the solenoid to the box and tighten to 14 in-lb (1.6 N·m). **See following WARNING.**

▲ WARNING

- **Incorrect wiring could result in severe injury or death.**
 - **Diode and solenoid connections must have correct polarity.**
 - **Keep all persons clear of engine belts when making final connections.**
2. Connect all wires as indicated.
 - 2.1. Connect the 6 gauge white wire from the starter/generator, and the 12 gauge white wire to the large post on the solenoid. **See Wiring Diagram, Section 11, Page 11-6.**
 - 2.2. Connect the 6 gauge red wire from the battery, the 10 gauge red wire from the fuse block, the 18 gauge red wire from the voltage regulator, and the 12 gauge red wire from the diode to the other large post on the solenoid.
 - 2.3. Connect the 18 gauge blue wire from the key switch to the small post on the solenoid.
 - 2.4. Connect the 18 gauge green wire from the Forward/Reverse limit switch to the other small post on the solenoid.
 3. Tighten the hex nuts on the large solenoid posts to 60 in-lb (6.8 N·m). Tighten the nuts on the small solenoid posts to 22 in-lb (2.5 N·m).
 4. Install the snap-on electrical box cover by firmly pressing down on all corners and install the screw, tightening to 18 in-lb (2 N·m).
 5. Connect battery cables, positive cable first and tighten the terminals to 20 ft-lb (27.1 N·m). Coat terminals with Battery Protector Spray (CCI 1014305).

FUSE

Read **DANGER** and **WARNING** on page 12-1.

Testing the Fuse

See Test Procedure 2, Section 11, Page 11-24.

Fuse Removal

1. Disconnect the battery cables, negative cable (–) first (**Figure 12-1, Page 12-2**).
2. Remove electrical component box cover.
3. Remove the fuse from the fuse block.

Fuse Installation

1. Install the fuse. See following **WARNING**.

WARNING

- If a fuse is blown, determine the cause of the failure and make necessary repairs before installing a new fuse. Use the appropriately rated fuse; if a fuse with a higher amp rating is used, damage to the vehicle electrical system may occur.
2. Install the snap-on electrical box cover by firmly pressing down on all corners and install the screw, tightening to 18 in-lb (2 N·m).
 3. Connect battery cables, positive cable first and tighten the terminals to 20 ft-lb (27.1 N·m). Coat terminals with Battery Protector Spray (CCI 1014305).

LOCKOUT CAM LIMIT SWITCH

Read **DANGER** and **WARNING** on page 12-1.

Testing the Lockout Cam Limit Switch

See Test Procedure 7, Section 11, Page 11-28.

Lockout Cam Limit Switch Removal

1. Disconnect the battery cables, negative cable (–) first (**Figure 12-1, Page 12-2**).
2. Disconnect the wires from the lockout cam limit switch (5) located on the back of the Forward/Reverse shifter assembly (**Figure 12-20, Page 12-19**).
3. Remove two nuts (2) and washers (6) from the lockout cam limit switch (5) and slide the lockout cam limit switch off of the screws.

Lockout Cam Limit Switch Installation

1. Install the lockout cam limit switch (5) with two washers (6) and two nuts (2) (**Figure 12-20, Page 12-19**). Tighten to 5 in-lb (0.6 N·m). Place the Forward/Reverse handle in REVERSE to make sure that both switches actuate. **See following CAUTION.**

▲ CAUTION

- Do not overtighten the retaining nuts. If the nuts are overtightened, limit switches could be damaged.
2. Connect wires to the lockout cam limit switch.
 - 2.1. Connect the black wire to the common (COM) terminal and the green wire to the normally open (NO) terminal of the lockout cam limit switch. **See Wiring Diagram, Section 11, Page 11-6.**
 3. Connect battery cables, positive cable first and tighten the terminals to 20 ft-lb (27.1 N·m). Coat terminals with Battery Protector Spray (CCI 1014305).

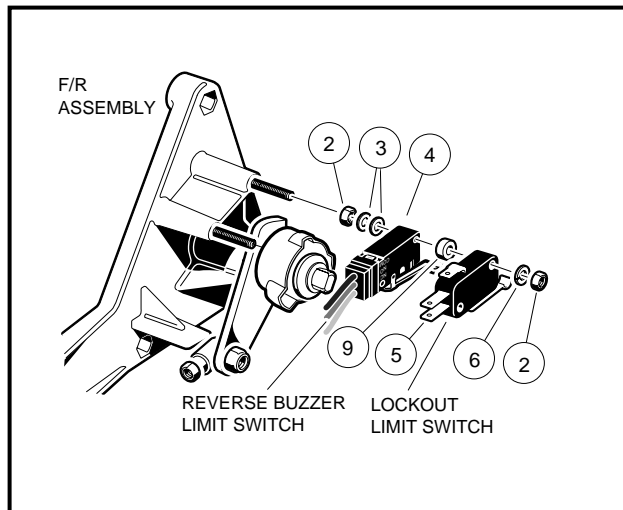

Figure 12-20 Lockout Cam & Reverse Buzzer Limit Switches

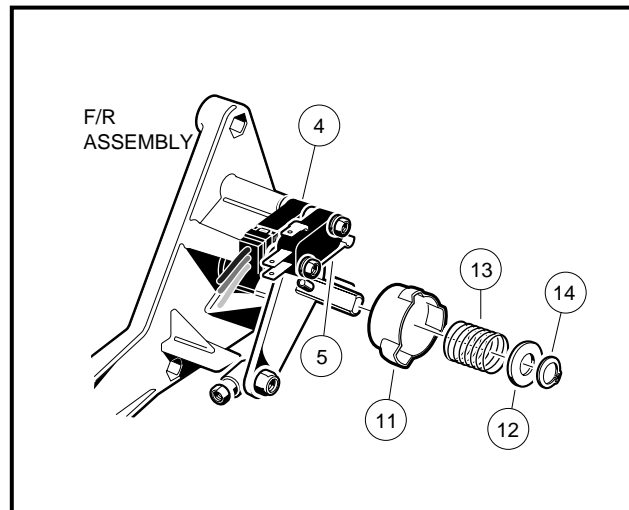

Figure 12-21 Lockout Cam

4. Check limit switch operation.
 - 4.1. Place the Forward/Reverse handle in the NEUTRAL position. The lockout cam should be activating the lockout cam limit switch. Make sure everyone is clear of the vehicle. Turn the key switch to the START position. The engine should crank only when the Forward/Reverse handle is in the NEUTRAL position.
5. Test drive the vehicle and attempt cranking the engine in both forward and reverse for proper operation.

LOCKOUT CAM

Read DANGER and WARNING on page 12-1.

If the cam lobes have worn to the point where they will no longer actuate the lockout cam limit switch, the cam must be replaced.

Testing the Lockout Cam

See Test Procedure 23, Section 11, Page 11-38.

Lockout Cam Removal

1. Disconnect the battery cables, negative cable (–) first (**Figure 12-1, Page 12-2**).
2. Remove the external snap ring (14) (**Figure 12-21, Page 12-19**).
3. Remove the plastic washer (12) and the spring (13).
4. Remove the cam (11).

Lockout Cam Installation

1. Install the cam (11) (**Figure 12-21, Page 12-19**).
2. Install the spring (13) and the plastic washer (12).
3. Install the external snap ring (14) onto the shaft. Be sure the snap ring is installed in the groove on the shaft. Also be sure that the cam is installed so that the lockout limit switch is activated only when the Forward/Reverse handle is in the NEUTRAL position.
4. Connect battery cables, positive cable first and tighten the terminals to 20 ft-lb (27.1 N·m). Coat terminals with Battery Protector Spray (CCI 1014305).

REVERSE WARNING BUZZER

Read DANGER and WARNING on page 12-1.

Testing the Reverse Warning Buzzer

See Test Procedure 20, Section 11, Page 11-37.

Reverse Warning Buzzer Removal

1. Disconnect the battery cables, negative cable (–) first (**Figure 12-1, Page 12-2**).
2. Remove the dash panel. **See Key Switch Removal on page 12-15.**
3. Disconnect the wires from the reverse warning buzzer (2) (**Figure 12-22, Page 12-21**).
4. Remove the screw (3) and nut (4) securing the buzzer to the vertical frame support.

Reverse Warning Buzzer Installation

1. Install the screw (3) through the buzzer (2) bracket tab and secure with nut (4). Tighten to 14 in-lb (1.6 N·m) (**Figure 12-22, Page 12-21**).

NOTE: The reverse warning buzzer is secured at one hole only.

2. Connect the black wire from the wire harness to the negative (–) terminal on the buzzer.
3. Connect the red/white wire from the wire harness to the positive (+) terminal on the buzzer.
4. Reverse removal procedures to reinstall the dash panel on the vehicle.
5. Connect battery cables, positive cable first and tighten the terminals to 20 ft-lb (27.1 N·m). Coat terminals with Battery Protector Spray (CCI 1014305).

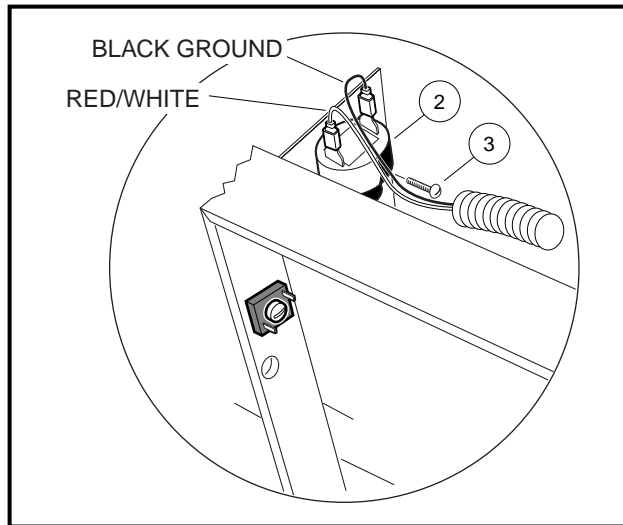

Figure 12-22 Front Reverse Warning Buzzer

REVERSE BUZZER LIMIT SWITCH

Read **DANGER** and **WARNING** on page 12-1.

Testing the Reverse Buzzer Limit Switch

See Test Procedure 19, Section 11, Page 11-37.

Reverse Buzzer Limit Switch Removal

1. Disconnect the battery cables, negative cable (–) first (**Figure 12-1, Page 12-2**).
2. Disconnect the wires from the reverse buzzer limit switch (4) located on the back of the Forward/Reverse assembly (**Figure 12-20, Page 12-19**).
3. Remove the nuts (2) and washers (6) from the lockout cam limit switch (5) and slide the lockout cam limit switch off of the screws. Do not disconnect the wires.
4. Remove the spacers (9) from the reverse buzzer limit switch (4) and slide the reverse buzzer limit switch off the screws.

Reverse Buzzer Limit Switch Installation

1. Install the reverse buzzer limit switch (4), and then install two spacers (9) against the limit switch.
2. Install the lockout cam limit switch (5) with two washers (6) and two nuts (2). Tighten to 5 in-lb (0.6 N·m). **See following CAUTION.**

⚠ CAUTION

- Do not overtighten the retaining nuts. If the nuts are overtightened, limit switches could be damaged.
3. Place the Forward/Reverse handle in REVERSE to make sure that only the reverse buzzer limit switch is actuated.
 4. Connect the orange wire to the common (COM) terminal and the red/white wire to the normally open (NO) terminal of the reverse buzzer limit switch (4) (**Figure 12-20, Page 12-19**).
 5. Connect battery cables, positive cable first and tighten the terminals to 20 ft-lb (27.1 N·m). Coat terminals with Battery Protector Spray (CCI 1014305).
 6. Turn the key switch to the ON position. Shift the Forward/Reverse handle to the REVERSE position. The buzzer should sound.

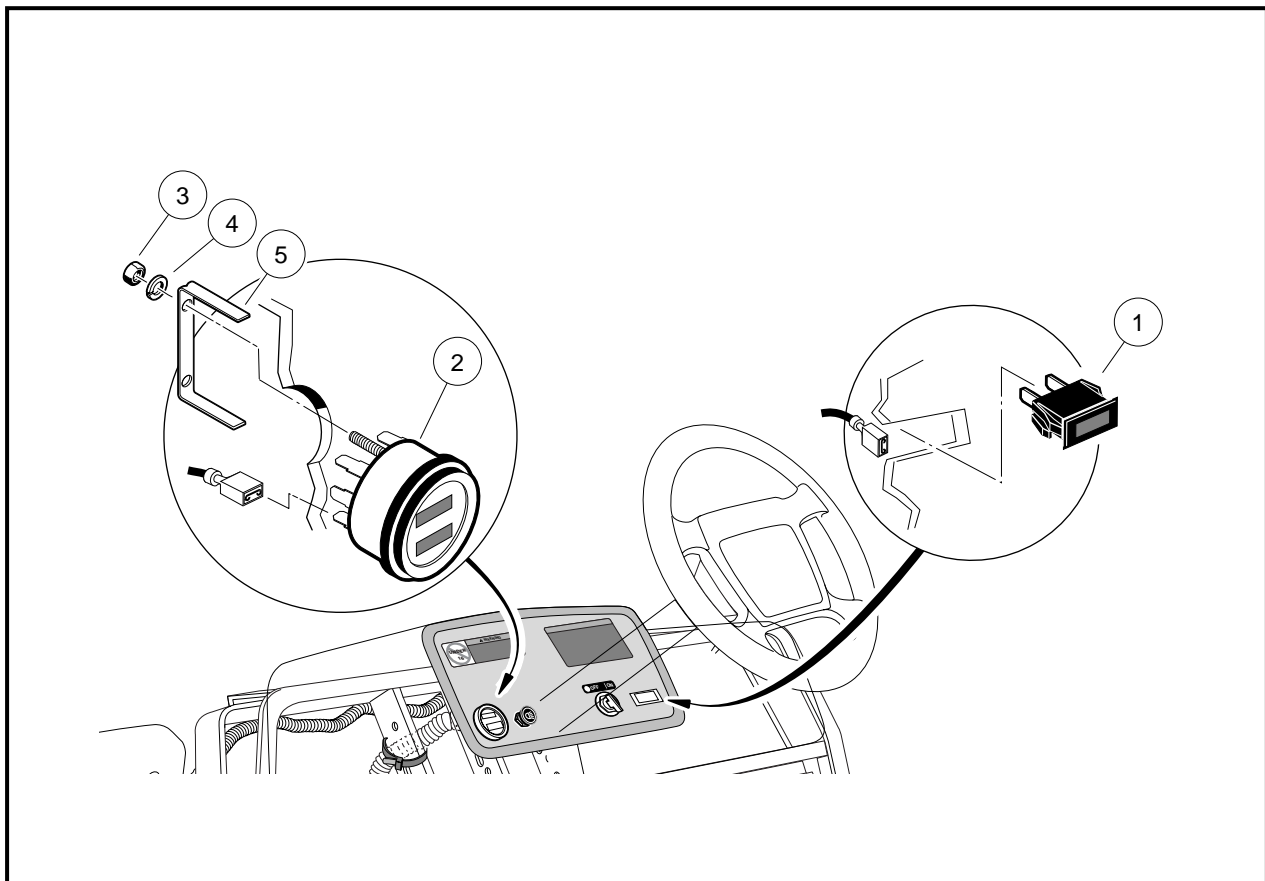

Figure 12-23 Fuel/Hour Gauge and Oil Warning Light Installation

OIL WARNING LIGHT

Read **DANGER** and **WARNING** on page 12-1.

Testing the Oil Warning Light

See **Test Procedure 22, Section 11, Page 11-38**.

Oil Warning Light Removal

1. Disconnect the battery cables, negative cable (–) first (**Figure 12-1, Page 12-2**).
2. Remove the dash panel. **See Key Switch Removal on page 12-15.**
3. Disconnect the wires from the oil warning light (1) (**Figure 12-23, Page 12-22**). Do not allow wires to touch.
4. Depress the retaining tabs and remove the light from the center dash.

Oil Warning Light Installation

1. Push a new unit into hole in dash until plastic tabs engage dash (**Figure 12-23, Page 12-22**).
2. Connect the two yellow wires from the wire harness to the oil warning light.
3. Install the dash in reverse order of removal.
4. Connect battery cables, positive cable first and tighten the terminals to 20 ft-lb (27.1 N·m). Coat terminals with Battery Protector Spray (CCI 1014305).

FUEL/HOUR GAUGE

Read **DANGER** and **WARNING** on page 12-1.

Testing the Fuel/Hour Gauge

See **Section 11, Test Procedure 26, Page 11-40, and Test Procedure 27, Page 11-41.**

With the key switch in the OFF position, the fuel/hour gauge fields are blank. When the key switch is turned to ON, both fields activate. The fuel gauge initially registers full for a brief moment before indicating the actual fuel level.

The hour gauge displays the number of hours of use in increments of .1 hour, but does not record additional time unless the key switch is in the ON position. When the hour gauge is recording, the hourglass icon at the left of the field blinks slowly.

Fuel/Hour Gauge Removal

1. Disconnect the battery cables, negative cable (–) first (**Figure 12-1, Page 12-2**).
2. Remove the dash panel. **See Key Switch Removal on page 12-15.**
3. Disconnect the wires from the fuel/hour gauge (2) (**Figure 12-23, Page 12-22**). Do not allow wires to touch.
4. Remove the two hex nuts (3) and lock washers (4) from the threaded studs on the back of the gauge. Remove the mounting bracket (5) from the back side of the gauge and remove the gauge from the dash.

Fuel/Hour Gauge Installation

1. Install a new gauge into hole in dash until flange seats against dash (**Figure 12-23, Page 12-22**).
2. Slide the mounting bracket onto the two threaded studs on the fuel/hour gauge and secure with two lock washers and two hex nuts. Tighten to 2.5 in-lb (.28 N·m). Place one drop of Loctite™ on each hex nut. Do not allow Loctite to come into contact with the fuel/hour gauge casing.
3. Connect the orange wire from the fuel level sending unit to the No. 1 terminal, the blue wire to the No. 2 terminal, the white wire to the No. 4 terminal, and the black wire to the No. 3 terminal on the fuel/hour gauge. **See Wiring Diagram, Section 11, Page 11-6.**
4. Coat the terminals with Battery Protector Spray (CCI 1014305).
5. Install the dash panel in reverse order of removal.
6. Connect battery cables, positive cable first and tighten the terminals to 20 ft-lb (27.1 N·m). Coat terminals with Battery Protector Spray (CCI 1014305).

FUEL LEVEL SENDING UNIT

Read DANGER and WARNING on page 12-1.

The fuel level sending unit is an integral part of the fuel tank and should never be removed. Thoroughly test the fuel level sending unit before replacing the fuel tank.

Testing the Fuel Level Sending Unit

See Test Procedure 25, Section 11, Page 11-39.

RPM LIMITER

Read DANGER and WARNING on page 12-1.

Testing the RPM Limiter

See Test Procedure 15, Section 11, Page 11-34.

RPM Limiter Removal

1. Access the engine compartment. **See DANGER on page 12-1.**
 - 1.1. Tilt the bed and ensure that the prop rod is engaged.
 - 1.2. Remove both seats from the vehicle.
2. Disconnect the battery cables, negative cable (–) first (**Figure 12-1, Page 12-2**).
3. Disconnect the white/black wire from the black wire at the bullet connector located near the RPM limiter (**Figure 12-24, Page 12-25**).
4. Disconnect the other black wire at the other bullet connector near the RPM limiter.
5. Remove the flange head bolts from the RPM limiter band and remove the RPM limiter and damper (**Figure 12-24, Page 12-25**).

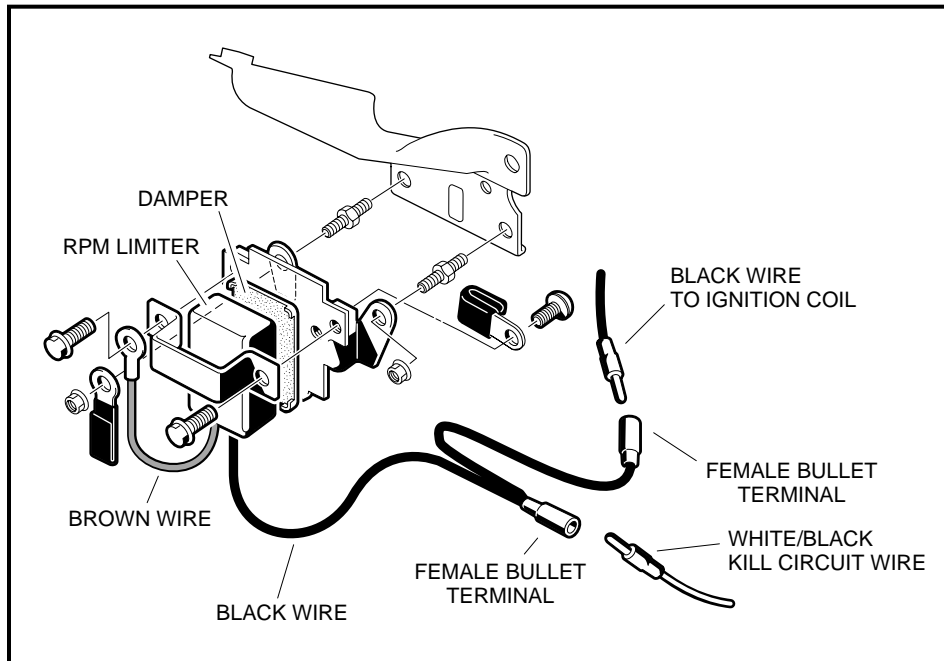

Figure 12-24 RPM Limiter Assembly

RPM Limiter Installation

1. Place the RPM limiter damper on the front of the RPM limiter mounting bracket (**Figure 12-24, Page 12-25**).
2. Place the RPM limiter on the damper squarely so that RPM limiter fits tightly against the damper.
3. Place the band over the RPM limiter and align the holes. Place the brown wire ring connector onto the flange head bolt and secure the left side of the band. Use another flange head bolt to secure the other side of the band. Make sure the band holds the RPM limiter securely in place. Tighten fasteners to 7 ft-lb (9.5 N·m).
4. Reconnect black wire at the bullet connector to the white/black wire.
5. Connect battery cables, positive cable first and tighten the terminals to 20 ft-lb (27.1 N·m). Coat terminals with Battery Protector Spray (CCI 1014305).
6. Release the prop rod and lower the bed.

IGNITION COIL

Read **DANGER** and **WARNING** on page 12-1.

Testing the Ignition Coil

See Section 11, Test Procedure 14, Page 11-33, and Test Procedure 15, Page 11-34.

Ignition Coil Removal

1. Access the engine compartment. **See DANGER** on page 12-1.
 - 1.1. Tilt the bed and ensure that the prop rod is engaged.
2. Disconnect the battery cables, negative cable (–) first (**Figure 12-1, Page 12-2**).
3. Unplug spark plug wire from the spark plug.

4. Remove the muffler. **See Section 15 – Exhaust System.**
5. Cut the wire tie holding the wire harness to the stiffener (1) and remove the bolts (2) and nuts (3) securing the stiffener to the mounting plate (4) (**Figure 12-25, Page 12-26**).
6. Remove the pan head bolts (5) securing the fan shroud (8) to the fan housing (9) (**Figure 12-26, Page 12-26**).
7. Loosen but do not remove three bolts (6) attaching the fan housing as shown.
8. Remove the remaining four bolts (10) attaching the fan housing as shown (**Figure 12-26, Page 12-26**), then while opening the housing, detach the spark plug wire grommet (4) from the housing (**Figure 12-28, Page 12-27**).
9. Disconnect the 18 gauge black wire (12) from the spade terminal on the ignition coil (11) and remove the coil by removing two bolts (10) (**Figure 12-27, Page 12-26**).

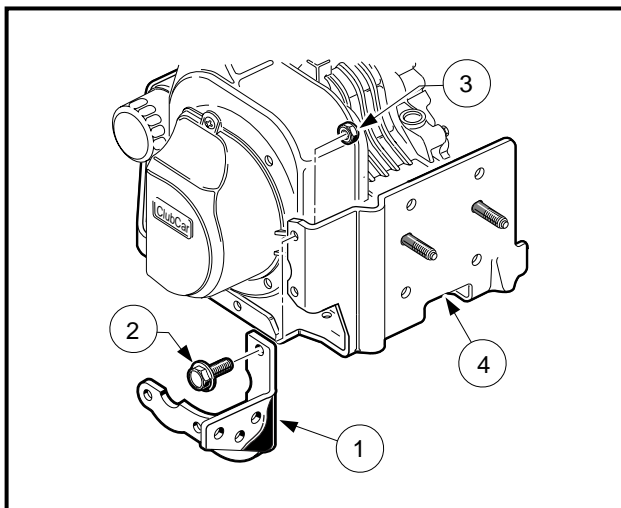

Figure 12-25 Remove Stiffener

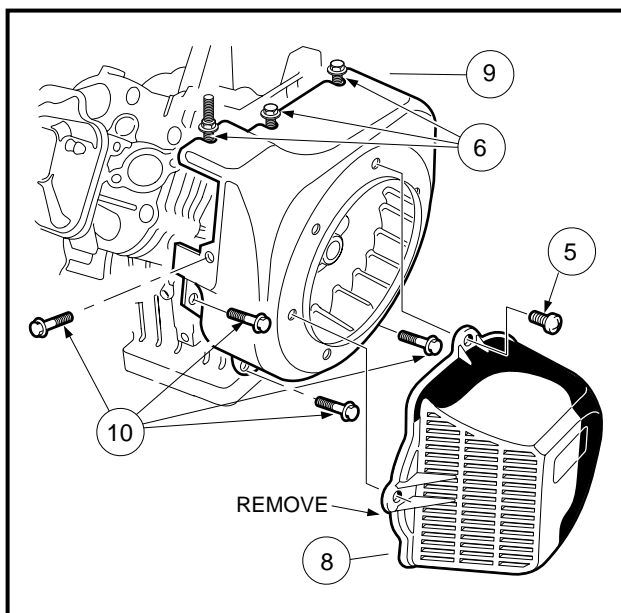

Figure 12-26 Remove Fan Housing

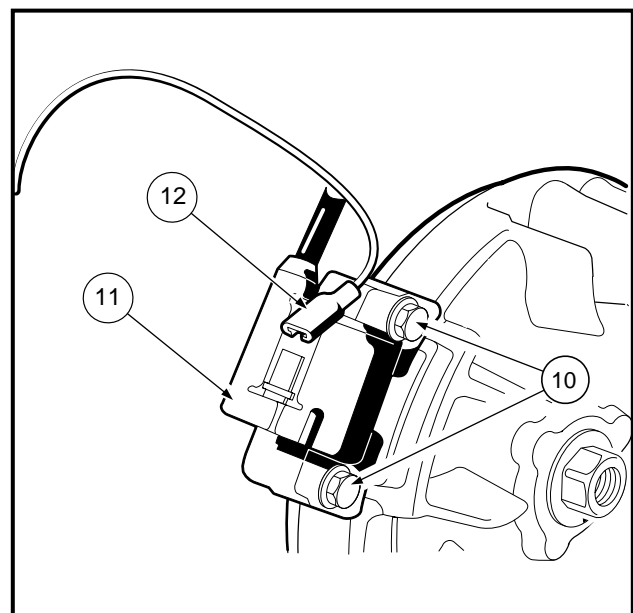

Figure 12-27 Remove Ignition Coil

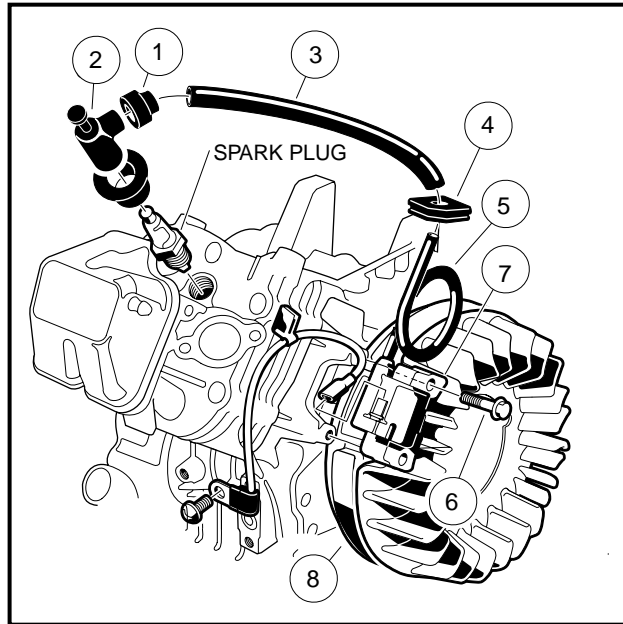

Figure 12-28 Clean Grommet

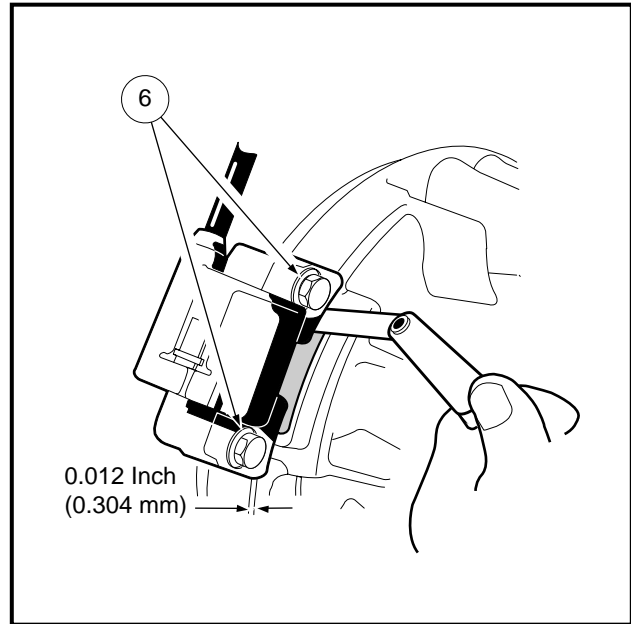

Figure 12-29 Mount Ignition Coil Using Feeler Gauge

Ignition Coil Installation

NOTE: If a new ignition coil is being installed, the spark plug cap, gasket, protector tube and grommet must be removed from the old coil and installed on the new coil. **See steps 1 through 8 for procedures to remove and install these existing parts.**

If the existing ignition coil will be remounted, proceed to step 9.

1. Remove the rubber gasket (1) on the plug cap (2) by rolling back the gasket onto the spark plug wire.
2. Remove the cap (2) from the wire by turning the cap counterclockwise three or four revolutions while gently pulling it off the wire (**Figure 12-28, Page 12-27**).
3. Remove the gasket (1) and protector tube (3) from the old coil.

NOTE: Moisten the spark plug wire with water to make gasket removal and installation easier.

4. Remove the grommet (4) from the old spark plug wire. Clean the grommet and place it on the new spark plug wire (5).
5. Install the protector tube onto the new wire.
6. Slide the gasket onto the end of the new spark plug wire.
7. Install the cap on the new coil spark plug wire by rotating it clockwise three or four revolutions while applying light pressure on the cap.
8. Install the gasket (1) on the cap (2).
9. Position the ignition coil (7) onto the cast mounting bosses on the engine crankcase and tighten the two mounting bolts (6) to finger tight at this time.

10. Rotate the flywheel (8) until the magnet is positioned directly under the ignition coil. Use a 0.012" (0.304 mm) bronze feeler gauge to set the air gap between the ignition coil and the flywheel magnet. Tighten the two mounting bolts (6) to 30 in-lb (3.4 N·m) **(Figure 12-29, Page 12-27)**.
11. Connect the 18 gauge black wire to the spade terminal on the coil.
12. Position the fan housing close to the engine crankcase and slide the plug wire grommet into the notch on the housing.
13. When installing fan housing, make sure the top front corner of the housing is above the upper cylinder shroud. The front edge of the fan housing should be behind the lower cylinder shroud. Align the slots in the housing with the flanged bolts loosened earlier.
14. Install the four remaining flange bolts that secure the fan housing to the engine crankcase. Tighten all seven mounting bolts to 90 in-lb (10.2 N·m) **(Figure 12-26, Page 12-26)**.
15. Install the stiffener with four hex head bolts and lock nuts. Tighten the hardware to 23 ft-lb (30.5 N·m) **(Figure 12-25, Page 12-26)**.
16. Install the fan shroud with four pan head bolts. Tighten the hardware to 50 in-lb (5.7 N·m) **(Figure 12-26, Page 12-26)**.
17. Secure the wire harness to the stiffener with a wire tie. Place the wire tie through the lower hole at the back of the stiffener **(Figure 12-25, Page 12-26)**.

⚠ CAUTION

- *Make sure wire harness is routed and secured away from the muffler.*

18. Install the muffler. **See Section 15 – Exhaust System.**
19. Connect the spark plug wire to the spark plug.
20. Connect battery cables, positive cable first and tighten the terminals to 20 ft-lb (27.1 N·m). Coat terminals with Battery Protector Spray (CCI 1014305).

OIL LEVEL SENSOR

Read DANGER and WARNING on page 12-1.

Testing the Oil Level Sensor

See Test Procedure 21, Section 11, Page 11-38.

Oil Level Sensor Removal

See Oil Level Sensor Removal, Section 13, Page 13-24.

Oil Level Sensor Installation

See Oil Level Sensor Installation, Section 13, Page 13-24.

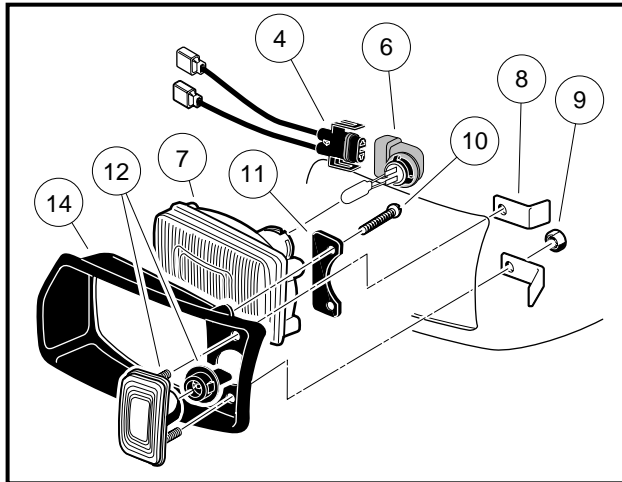

Figure 12-30 Headlight Assembly

HEADLIGHTS

Read **DANGER** and **WARNING** on page 12-1.

Testing the Headlight Bulb and Socket

See Test Procedure 30, Section 11, Page 11-43.

Headlight Bulb Removal

1. Disconnect the battery cables, negative cable (–) first (**Figure 12-1, Page 12-2**).
2. From the front of vehicle, reach under cowl and turn the wire harness/halogen bulb assembly, (4 and 6), clockwise one-quarter turn (**Figure 12-30, Page 12-29**).
3. Remove the wire harness/halogen bulb assembly (4 and 6) from the headlight lens (7).
4. Lift the retaining tabs on the connector (4) and remove halogen bulb assembly (6).

Headlight Bulb Installation

NOTE: When handling halogen bulbs, do not touch glass portion of bulb. Oil from finger tips can cause premature failure of bulb.

1. Connect wire harness (4) to the halogen bulb assembly (6). The retaining tab should lock onto the halogen bulb assembly (**Figure 12-30, Page 12-29**).
2. From the front of vehicle, reach under cowl and insert wire harness/halogen bulb assembly (4 and 6), into the headlight lens (7).
3. Turn the wire harness/halogen bulb assembly (4 and 6) counterclockwise one-quarter turn.
4. Connect battery cables, positive cable first and tighten the terminals to 20 ft-lb (27.1 N·m). Coat terminals with Battery Protector Spray (CCI 1014305).

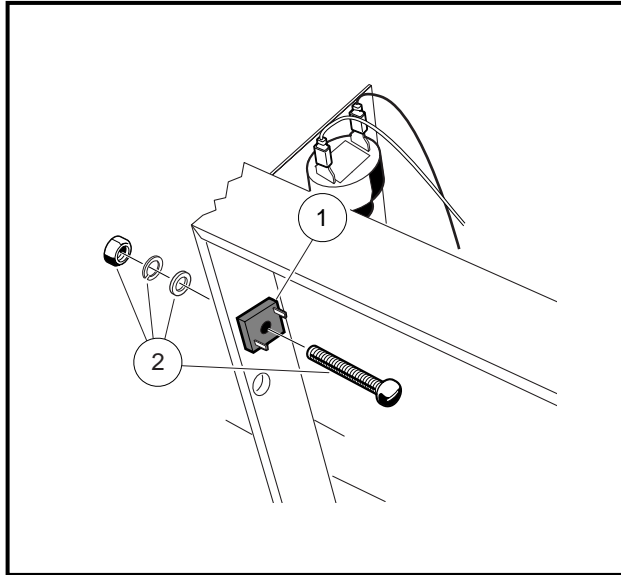

Figure 12-31 Headlight Diode

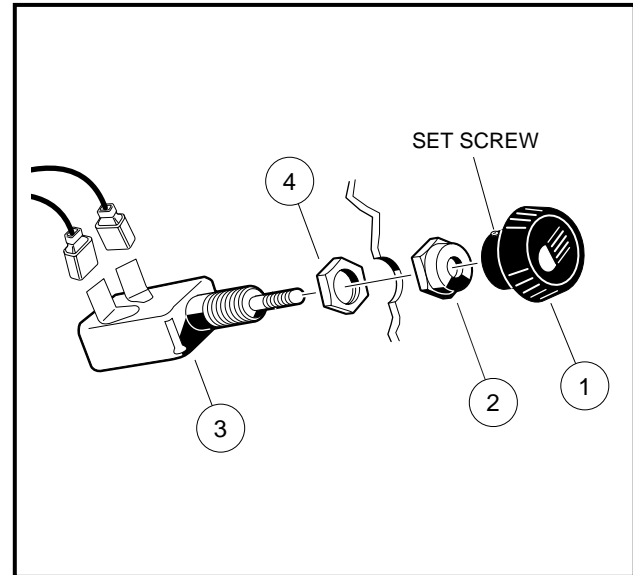

Figure 12-32 Light Switch

HEADLIGHT DIODE

Read **DANGER** and **WARNING** on page 12-1.

Testing the Headlight Diode

See Test Procedure 29, Section 11, Page 11-42.

Headlight Diode Removal

1. Disconnect the battery cables, negative cable (–) first (**Figure 12-1, Page 12-2**).
2. Remove the center dash panel. **See Key Switch Removal on page 12-15.**
3. Disconnect wires from the headlight diode (1) (**Figure 12-31, Page 12-30**).
4. Remove the mounting hardware (2) from the headlight diode and remove it from the vehicle.

Headlight Diode Installation

1. Mount the headlight diode to the frame using the mounting hardware. Tighten to 25 in-lb (2.8 N·m) (**Figure 12-31, Page 12-30**).
2. Connect the black 16 gauge wire from the harness to the negative terminal on the headlight diode.
3. Install the dash panel in reverse order of removal.
4. Connect battery cables, positive cable first and tighten the terminals to 20 ft-lb (27.1 N·m). Coat terminals with Battery Protector Spray (CCI 1014305).

LIGHT SWITCH

Read **DANGER** and **WARNING** on page 12-1.

Testing the Light Switch

See Test Procedure 28, Section 11, Page 11-41.

Light Switch Removal

1. Disconnect the battery cables, negative cable (–) first (**Figure 12-1, Page 12-2**).
2. Loosen the set screw locking the light switch knob (1) to the shaft (**Figure 12-32, Page 12-30**).
3. Remove the dash panel. **See Key Switch Removal on page 12-15.**
4. Disconnect the wires from the light switch.
5. Remove the outer nut (2) from the light switch (3) (**Figure 12-32, Page 12-30**).
6. Remove the light switch from the dash panel.

Light Switch installation

1. Reconnect the wires to the light switch. **See Wiring Diagram, Section 11, Page 11-6.**
2. Thread the check nut (4) onto the switch until an equal number of threads show on both sides. Insert the switch through the dash panel and install the nut (2) on the outside of the dash. Tighten the nut to 14 in-lb (1.6 N·m) (**Figure 12-32, Page 12-30**).
3. Push the light switch shaft in. Screw the knob onto the end of the shaft until the knob touches the outer nut. Then turn the knob in the opposite direction until the headlight beams on the knob are horizontal to the ground. Tighten the set screw to lock the knob to the shaft.
4. Install the dash panel in reverse order of removal.
5. Connect battery cables, positive cable first and tighten the terminals to 20 ft-lb (27.1 N·m). Coat terminals with Battery Protector Spray (CCI 1014305).

BATTERY

Read **DANGER** and **WARNING** on page 12-1.

▲ DANGER

- *Due to the danger of an exploding battery, wear a full face shield and rubber gloves when working around a battery.*
- *Battery – Explosive gases! Do not smoke. Keep sparks and flames away from the vehicle and service area. Ventilate when charging or using in an enclosed space. Wear a full face shield and rubber gloves when working on or near batteries. For added protection, cover top of the battery when servicing the vehicle.*
- *Battery – Poison! Contains acid! Causes severe burns! Avoid contact with skin, eyes, or clothing.*
 - *External: Flush with water. Call a physician immediately.*
 - *Internal: Drink large quantities of milk or water. Follow with milk of magnesia or vegetable oil. Call a physician immediately.*
 - *Eyes: Flush with water for 15 minutes. Call a physician immediately.*

General Information

See preceding DANGER statement.

Club Car gasoline vehicles are equipped with 12-volt, low-maintenance batteries. When changing a 12-volt battery in any Club Car gasoline-powered vehicle, the same size battery with adequate amperage ratings should be used as a replacement.

Club Car recommends a group 70, side-post battery (CCI 1012328), with a 650 cranking amp rating at 32 °F (0 °C) (500 CCA at 0 °F (-17.8 °C)) and a reserve capacity of at least 105 minutes. The group 70 classification indicates battery size: 8-1/4 inches W x 6-1/2 inches D x 7-1/4 inches H (21.0 cm W x 16.5cm D x 18.4 cm H). It is important to use the proper size to ensure that the battery clamp will fit correctly.

Testing the Battery

See Section 11, Test Procedure 1, Page 11-21, and Test Procedure 24, Page 11-39.

Preventive Maintenance

To keep the battery in good operating condition, follow these steps on a regular basis.

1. Any corrosion build-up on or around the battery should be removed immediately. Post connections should be clean and tight. Any frayed or worn wires should be replaced. After all cables have been connected and properly tightened to 20 ft-lb (27.1 N·m), coat terminals with Battery Protector Spray (CCI 1014305) to prevent future corrosion.
2. The battery should be kept clean and dry to prevent self-discharge. Any dirt, grime or acid spillage should be removed. Wash the battery with a bristle brush using water and bicarbonate of soda (baking soda – 1 cup per gallon). Rinse with water. Do not allow solution to enter battery through the vent cap holes. **See Self-Discharge on page 12-32.**
3. Maintain proper water level. **See Water Level on page 12-32.**
4. Check battery periodically to see that it is in a full state of charge. **See Charging the Battery on page 12-34.**
5. Keep battery hold-down clamp tight. **See Vibration Damage on page 12-33.**

Self-Discharge

Dirt and battery acid can provide a path for a small current draw that slowly discharges the battery. To prevent self-discharge, the battery should always be kept clean.

Hot weather also has an effect on a battery's self-discharge rate. The higher the temperature, the quicker a battery will discharge. In hotter climates, therefore, the battery should be checked more often. When storing the battery, keep in a cool place. **See Battery Storage on page 12-35.**

Water Level

The water level should be checked semi-annually to be sure water is at its proper level. Never allow the water level to fall below the tops of the plates because this will cause the exposed part of the plate to become permanently inactive. Check the water level more frequently in hot weather or when the battery becomes old. **See Figure 11-23, Section 11, Page 11-22.**

Vibration Damage

The battery hold-down clamp should always be tight enough to keep the battery from bouncing. Battery life may be severely shortened if the clamp is too loose. Excessive vibration shortens the life of the battery. It may also cause acid to leak out of the vent caps and corrosion to build up on surrounding metal parts. The acid which is lost reduces the capacity of the battery and cannot be replaced.

Mineral Content

For the longest battery life, distilled water should be used in the battery. However, if tap water is going to be used, contact your local water department to be sure mineral contents are below the levels listed in the following table. **See following NOTE.**

NOTE: Contact your local water department for mineral content analysis.

IMPURITY	ALLOWABLE CONTENT IN PARTS PER MILLION
Suspended matter	TRACE
Total solids	100.0
Calcium and magnesium oxides	40.0
Iron	5.0
Ammonia	8.0
Organic matter	50.0
Nitrates	10.0
Nitrites	5.0
Chloride	5.0

Battery Removal

Read DANGER and WARNING on page 12-1 and DANGER on page 12-31.

1. Chock the wheels and release the park brake.
2. Access the engine compartment. **See DANGER on page 12-1.**
 - 2.1. Tilt the bed and ensure that the prop rod is engaged.
3. Completely remove both seats from the vehicle.
4. Disconnect the battery cables, negative cable (–) first (**Figure 12-1, Page 12-2**).
5. Remove the four bolts, eight washers and four lock nuts from the armrests.
6. Remove the two armrests from the vehicle.
7. Carefully lift and rotate the seat support (1) 90° clockwise and allow it to rest on the vehicle body as illustrated (**Figure 12-33, Page 12-34**). **See following NOTE.**

NOTE: It is not necessary to remove the park brake cable or differential lock cable to service or remove the battery.

8. Remove the battery hold-down clamp from the battery.
9. Lift the battery from the vehicle. **See following WARNING.**

⚠ WARNING

- **Keep the battery in an upright position to prevent electrolyte leakage. Tipping the battery beyond a 45° angle in any direction can allow a small amount of electrolyte to leak out of the vent hole. Do not exceed this 45° angle when lifting, carrying or installing battery. The battery acid could cause severe personal injury when accidentally coming in contact with the skin or eyes, and could damage clothing.**

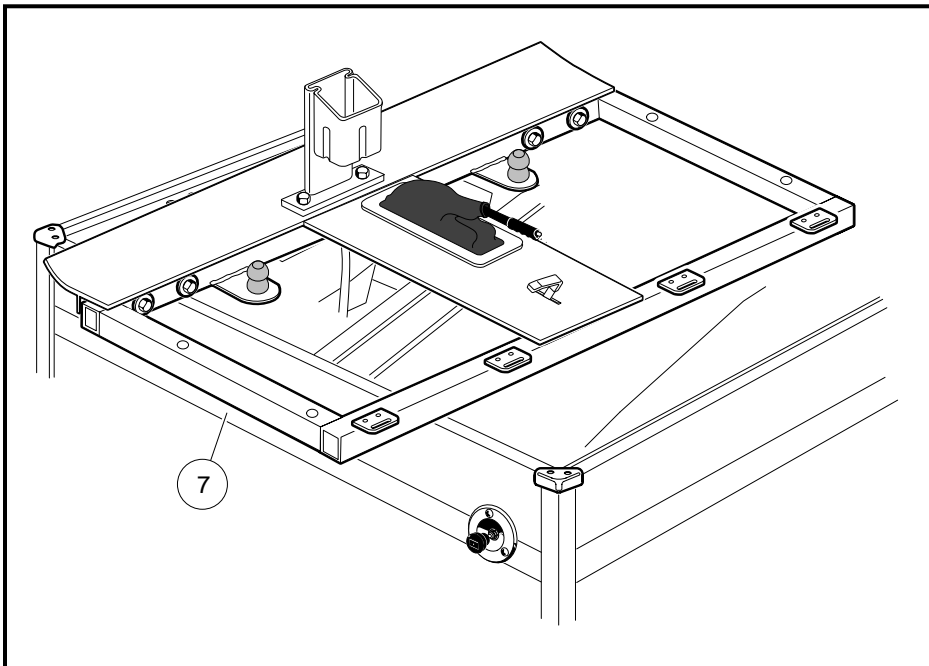

Figure 12-33 Battery Removal

Charging the Battery

Read **DANGER** and **WARNING** on page 12-1 and **DANGER** on page 12-31.

1. Charge the battery using an automotive type 12-volt battery charger. Follow all warnings and procedures supplied by the battery charger manufacturer.
2. Attach the positive charger cable (+) to the positive (+) battery post.
3. Attach the negative charger cable (-) to the negative (-) battery post.
4. The battery may be charged with a slow charge (3-10 amps) or a fast charge (20-30 amps). Charge until the specific gravity reaches 1.250. **See following WARNING.**

⚠ WARNING

- If the battery case feels hot (approximately 125 °F (52 °C) or more), emits gases, or fluid boils from vents, stop charging immediately. Failure to stop charging battery when any of these conditions are present could result in an explosion, personal injury and/or damage to the battery.
- Do not disconnect the DC leads and battery when the charger is on. The resulting arcing between the DC leads and battery post could cause an explosion.
- If the charger must be stopped, disconnect the AC supply cord from the wall outlet before disconnecting the DC leads from the battery. Allow the battery to cool to room temperature and resume charging battery at a lower amp rate.

Battery Installation

Read **DANGER** and **WARNING** on page 12-1 and **DANGER** on page 12-31.

1. Place the battery into the vehicle. Make sure the battery posts are facing the engine.
2. Secure the battery to the vehicle with the clamp. Install bolt, washer and locknut and tighten to 12 ft-lb (16.3 N·m).
3. Return the seat support to its original position by rotating it 90° counterclockwise. Install the armrests using four bolts, eight washers and four locknuts. Tighten bolts (8) to 13 ft-lb (17.6 N·m) (**Figure 4-2, Page 4-7**).
4. Lower the bed and place both seats on the vehicle. **See following WARNING.**

⚠ WARNING

- Do not disengage prop rod until all persons are clear of cargo bed area.
 - Do not drop tilt bed; lower gently and keep entire body clear. Failure to follow these instructions could result in severe injury.
 - Keep hands clear of crush area between bed and vehicle body.
5. Connect battery cables, positive cable first and tighten terminals to 20 ft-lb (27.1 N·m) (**Figure 12-1, Page 12-2**). Coat terminals with Battery Protector Spray (CCI 1014305).
 6. Check the park brake and differential lock lever for proper adjustment and operation.

Battery Storage

Read **DANGER** and **WARNING** on page 12-1 and **DANGER** on page 12-31.

1. Keep the battery clean and free of corrosion. **See Preventive Maintenance on page 12-32.**
2. The battery cables should be disconnected from the vehicle so it can be connected to the charger. The battery can be left in the vehicle.
3. Fully charge the battery prior to storage.
4. Store in a cool area. The colder the area in which the battery is stored, the less the battery will self-discharge. A battery stored at 0 °F (-17.8 °C) will discharge very little over a four-month period. A battery stored at 80 °F (27 °C) will have to be recharged every few weeks.
5. Check the state of charge periodically. A battery that is discharged and left in a cold environment can freeze and crack. If the specific gravity drops below 1.220, the battery should be recharged. **See following WARNING.**

⚠ WARNING

- If the battery is frozen or the container is bulged, discard battery. A frozen battery can explode.
6. The frequency of recharging required depends on the temperature of the storage area, but it is recommended that the battery be monitored for state of charge every month. Also, if the storage area is unheated in a cold climate and recharging is required, it is recommended that the area be heated to at least 60 °F (16 °C) prior to charging. The battery will not charge effectively in cold temperatures for the same reasons that it does not discharge as rapidly in cold temperatures.

Charging a Dead Battery

Read DANGER and WARNING on page 12-1 and DANGER on page 12-31.

The vehicle is equipped with a starter/generator. The generator is not designed to charge a dead battery. If the vehicle battery has become discharged, it must be charged using a properly rated automotive type charger.

⚠ WARNING

- Do not jump-start a dead battery using another battery and jumper cables.

GROUND STRAPS

Testing the Ground Straps

See Test Procedure 3, Section 11, Page 11-24.

SECTION 13 – FE350 ENGINE

⚠ DANGER

- *Gasoline vapors – Flammable – Do not smoke! Keep sparks and flames away from vehicle and service area. Tools, wires and metal objects can cause sparks when “shorted” across a battery. Insulated tools should be used. Extreme care should be taken when disconnecting or reconnecting the battery. When wires are disconnected, be sure to keep them away from battery terminals and other wires. Service only in well-ventilated areas.*
- *Do not operate vehicle in an enclosed area without proper ventilation. The engine produces carbon monoxide, which is an odorless, deadly poison.*

⚠ WARNING

- Only trained technicians should repair or service this vehicle. Anyone doing even simple repairs or service should have knowledge and experience in electrical and mechanical repair.
- Follow the procedures exactly as stated in this manual, and heed all DANGER, WARNING, and CAUTION statements in this manual as well as those affixed to the vehicle.
- Wear safety glasses or approved eye protection while servicing vehicle. Wear a full face shield and rubber gloves when working with batteries.
- Turn key switch OFF, place Forward/Reverse handle in the NEUTRAL position, and remove key before servicing the vehicle.
- Moving parts! Do not attempt to service the vehicle while it is running.
- Use insulated tools when working near batteries or electrical connections. Use extreme caution to avoid shorting of components or wiring.
- Frame ground – Do not allow tools or other metal objects to contact frame when disconnecting battery cables or other electric wiring. Never allow a positive wire to touch the vehicle frame, engine, or any other metal component.
- To avoid unintentionally starting the vehicle:
 - Disconnect the battery cables, negative cable (–) first. See Figure 12-1, Section 12, Page 12-2.
 - Disconnect the spark plug wire from the spark plug.
- Lift only one end of the vehicle at a time. Before lifting, set the park brake when lifting the front of the vehicle, unload the cargo bed, and chock the wheels that remain on the floor. Use a suitable lifting device (chain hoist or hydraulic floor jack) with 1000 lb. (454 kg) minimum lifting capacity. Do not use lifting device to hold vehicle in raised position. Use approved jack stands of proper weight capacity to support the vehicle.

GENERAL INFORMATION

Read **DANGER** and **WARNING** on page 13-1.

All Club Car gasoline vehicles are powered by 4-cycle, overhead valve, single cylinder, air-cooled engines. The 4-cycle engine has an oil reservoir (crankcase) similar to automobiles, trucks, aircraft, heavy equipment, machinery and other applications designed for reliable heavy-duty service. The engine has two major component assemblies: the cylinder assembly and the crankcase assembly. **See following NOTE.**

NOTE: Engine rotation is clockwise as viewed from the clutch side of the engine.

SPECIAL ENGINE SERVICE TOOLS AVAILABLE FROM CLUB CAR

DESCRIPTION	PART NUMBER
Gear yoke	1016418
Compression gauge and adapter	101641002
Valve spring compressor	101641101
Valve guide reamer	101641201
Valve guide reamer arbor	101641202
Piston ring compressor kit	1016414
Piston ring pliers	1016415
Bearing driver set	1016416
Flywheel puller kit	1016627
Valve clearance adjuster screw holder	1016413
Bearing and seal remover assembly	1016417
Valve seat cutter T wrench	1016551
Valve seat cutter 45° x 32 mm diameter (for FE290 engines only)	1016553
Valve seat cutter 30° and 45° x 35 mm diameter	1016554
Valve seat cutter guide	1016552

BEFORE SERVICING

To eliminate unnecessary work, carefully read the applicable information and instructions before beginning engine service. Diagrams, **DANGER**, **WARNING**, **CAUTION** and **NOTE** statements and detailed descriptions have been included wherever necessary. Nevertheless, even a detailed account has limitations. Therefore, anyone attempting engine service should have knowledge and experience in small engine service and repair.

MECHANICAL SYSTEMS

Adjustments

All adjustments shall be made in accordance with Section 10 – Periodic Maintenance.

Edges

▲ WARNING

- **Watch for sharp edges, especially during major engine disassembly and assembly. Protect your hands with gloves or a piece of thick cloth when lifting the engine or turning it over.**

Force

Common sense should dictate how much force is necessary for assembly and disassembly. If a part seems especially difficult to remove or install, stop and determine what may be causing the problem. Whenever tapping is necessary, tap lightly using a wooden or plastic-faced mallet. Use an impact driver for the removal of screws (particularly those held by a locking agent) in order to avoid damaging the heads.

Dirt

Clean the engine thoroughly before servicing it. **See following CAUTION.**

▲ CAUTION

- *Before removal and disassembly, clean the engine. Any dirt entering the engine, carburetor, or other parts will work as an abrasive and shorten the life of the engine. For the same reason, before installing a new part, clean off any dust or metal filings.*

Tightening Sequence

Where there is a tightening sequence indicated in this Service Manual, the bolts, nuts, or screws must be tightened in the order and by the method indicated. When installing a part that is secured with several bolts, nuts, or screws, hand tighten all, then tighten to specified torque in the proper sequence. This is to avoid distortion of the part and/or causing gas or oil leakage. Conversely, when loosening the bolts, nuts or screws, loosen all about a quarter of a turn first and then remove them.

Torque

The torque values given in this Service Manual should always be adhered to. Applying too little or too much torque may lead to serious damage.

Lubricant

Some oils and greases should only be used in certain applications and may be harmful if used in an application for which they are not intended.

Lubrication

Engine wear is generally at its maximum while the engine is warming up and before all the rubbing surfaces have adequate lubrication. During assembly, oil or grease (whichever is more suitable) should be applied to any rubbing surface.

Press

A part installed using a press or driver, such as a seal, should first be coated with oil on its outer or inner circumference (contact surface) so that it will go into place smoothly.

Oil Seal, Grease Seal

During assembly use new oil or grease seals to replace any that were removed, as removal generally damages seals. To avoid damaging the seal lips, a seal guide is required for installation. Before a shaft passes through a seal, apply a small amount of lubricant (preferably high temperature grease) to the lip to reduce rubber-to-metal friction.

Gasket, O-Ring

When in doubt as to the condition of a gasket or O-ring, replace it with a new one. To avoid leaks, the mating surface around the gasket or O-rings should be free of foreign matter and perfectly smooth.

Liquid Gasket and Non-permanent Locking Agent

Follow manufacturer's directions for cleaning and preparing surfaces where these compounds will be used. Apply sparingly. Excessive amounts may block engine oil passages and cause serious damage.

Certain compounds can lead to premature gasket failure. Use the non-permanent locking agent Loctite[®], Lock'n Seal (Blue) or approved equivalent.

Ball Bearing Installation

When installing a ball bearing, the bearing race which has a press fit should be pushed by a suitable driver. This prevents severe stress on the balls and races, and prevents damage. Press on the inner race if the ball bearing is being pressed onto a shaft, or on the outer race if the ball bearing is being pressed into a housing. Press the ball bearing until it is seated against the housing or on the shaft.

Circlip, Retaining Ring

Replace circlips and retaining rings that were removed with new circlips and retaining rings, as removal weakens and deforms them. During installation, take care to compress or expand them only enough for installation.

High Flash-point Solvent

To reduce fire danger a high flash-point solvent is recommended. A commercial solvent commonly available in North America is Stoddard solvent (generic name). Always follow manufacturer and container directions regarding the use of any solvent.

Molybdenum Disulfide (MoS₂) Grease

NOTE: This manual makes reference to molybdenum disulfide grease in the assembly of certain engine and chassis parts. Check manufacturer recommendations before using such special lubricants.

Engine Rotation

When turning the crankshaft by hand, always turn it **clockwise** as viewed from the clutch side of the engine. This will ensure proper adjustments.

ELECTRICAL SYSTEM

See also Section 11 – Troubleshooting and Electrical System and Section 12 – Electrical Components.

1. Always minimize shock hazards when working on electrical equipment. Work in a clean, dry environment with dry hands.

2. Electrical parts should never be struck sharply, as with a hammer, or allowed to fall on a hard surface. Such a shock can damage an electrical part.
3. Never replace a defective electrical component without first determining what caused the failure. If the failure was brought on by some other item or items, they too must be repaired or replaced before using the vehicle.
4. Make sure all connectors in the circuit are clean and tight, and examine wires for signs of overheating, fraying, etc. Wires in poor condition and bad connections will affect electrical system operation.
5. Measure coil and winding resistance when the part is cold (at room temperature).
6. All the electrical leads are either single-color or two-color and, with only a few exceptions, must be connected to leads of the same color. On any of the two-color leads, there is a greater amount of one color and a lesser amount of a second color, so a two-color lead is identified by first the primary color and then the secondary color. For example, a yellow wire with a thin red stripe is referred to as a "yellow/red" wire.

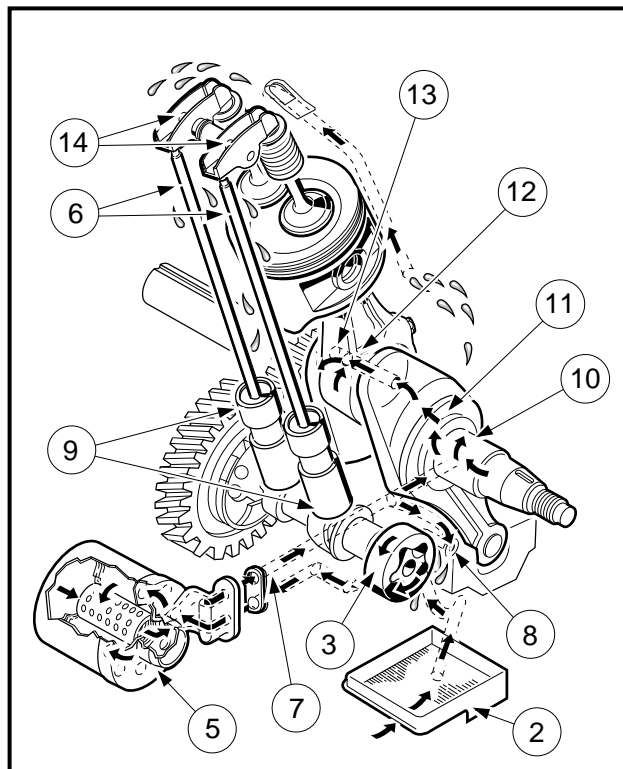

Figure 13-1 Lubrication System

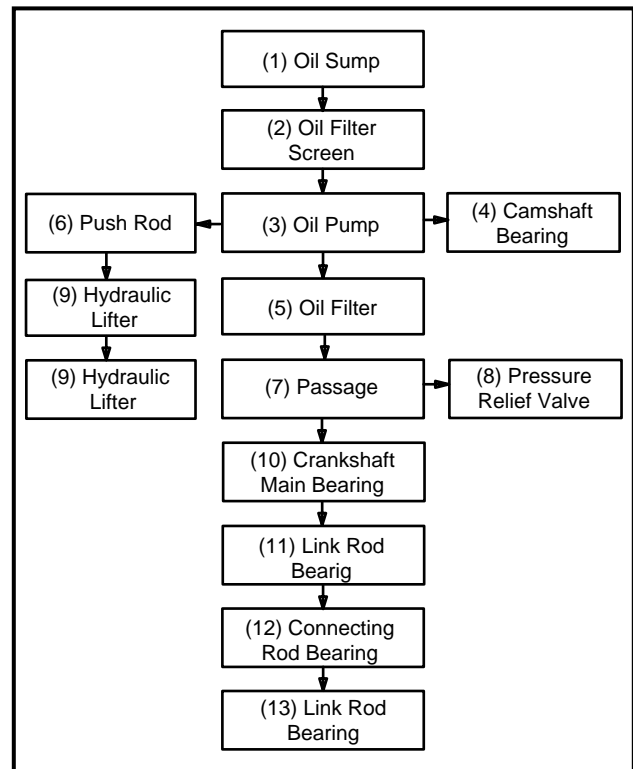

Figure 13-2 Lubrication System Flow Chart

LUBRICATION SYSTEM

FE350 engines are equipped with hydraulic lifters and a pressurized lubrication system which consists of these components (Figure 13-1, Page 13-5 and Figure 13-3, Page 13-6):

- Inlet filter screen (2)
- Trochoid pump (3)
- Cartridge filter (5)
- Pressure relief valve (8)

The pump draws oil from the sump and forces it under pressure into the crankcase passages as shown (**Figures 13-1 and 13-2, Page 13-1**). Oil can build up excess pressure in a lubrication system. To prevent build-up of excess oil pressure which could possibly force oil past the seals and damage the engine, the pump is fitted with a pressure relief valve (8) (**Figure 13-1, Page 13-5 and Figure 13-3, Page 13-6**) that is made of a ball and a spring. When the pressure increases beyond the pressure of the spring, the ball is forced off its seat against the spring pressure and excess oil is routed back into the sump (crankcase), thus relieving the pressure. When the pressure drops below the preset limit, the spring holds the ball against its seat to keep the oil from draining back into the sump (crankcase).

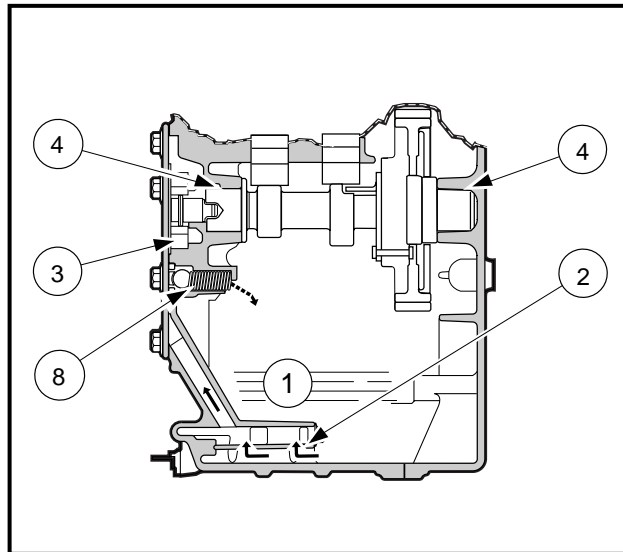

Figure 13-3 Cutaway View of Crankcase

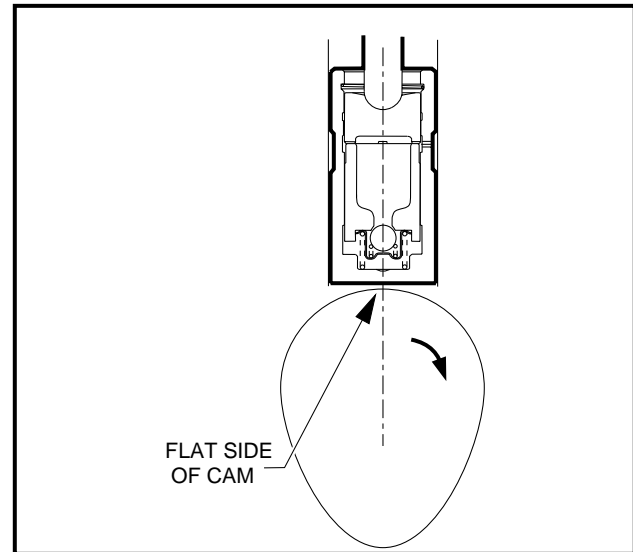

Figure 13-4 Cam Position for Lifter Installation

HYDRAULIC LIFTERS

FE350 engines are equipped with non-adjustable rocker arms (14) and hydraulic lifters (9) (**Figure 13-1, Page 13-5**). The purpose of hydraulic lifters is to automatically eliminate all valve clearance in the valve train. This zero-clearance condition ensures that the valve begins to open at precisely the same time during each valve event. However, to ensure good seating, there is a small amount of clearance present after the valve closes. This clearance is eliminated by the lifter before the valve is opened again. The installation of the hydraulic lifters at the time of engine assembly does not, in most cases, require any special techniques beyond the normal practice for solid lifter valve trains. There are, however, two areas of concern to be aware of to assure satisfactory installation and initial engine start. New hydraulic lifters are filled with hydraulic fluid at the time of installation and they are at their fully extended position. As each rocker arm is tightened into place, the lifter should be resting on the flat side of the cam lobe (**Figure 13-4, Page 13-6**). If the camshaft is not in the correct position, it may be possible to open the valve beyond its normal operating range. This may cause over-compensation of the valve spring or contact between the valves and the piston.

SPARK PLUG

Spark plugs are selected to suit specific engine design and vehicle operating conditions. The spark plug (CCI 101881101) is designed to give maximum life and efficient combustion of fuel. The spark gap is 0.027 to 0.031 in. (0.69 to 0.79 mm).

Spark Plug Removal

Read **DANGER** and **WARNING** on page 13-1.

▲ CAUTION

- Before removal and disassembly, clean the engine.

Remove all dirt from plug base in the cylinder head before removing plug. Use a 13/16 deep well socket wrench or 13/16 plug wrench to loosen the plug.

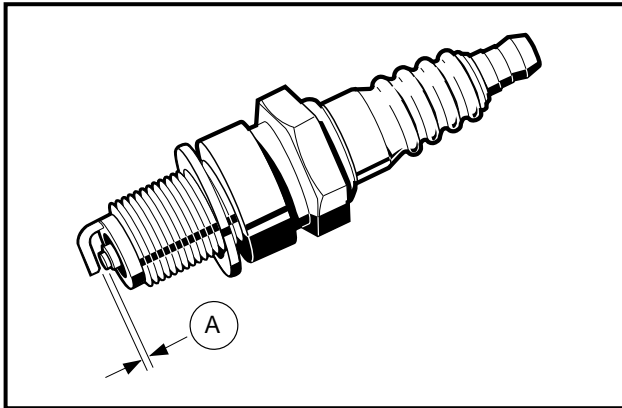

Figure 13-5 Spark Plug

Spark Plug Cleaning, Inspection and Repair

Examine the plug (**Figure 13-5, Page 13-7**). The deposits on the plug base and electrode are an indication of the correct heat range and efficiency as well as a guide to the general condition of the engine, fuel and air mixture and ignition system. If all of the above conditions are proper, the spark plug should be a light brown color. There should be no bridging between the electrode and base. The electrode should not be eroded. Black color, excessive carbon, and/or a wet plug indicate a too rich condition. White, burned or melted electrodes indicate a too lean condition or pre-ignition. Oily deposits on the plug electrode are an indication of worn rings, valve guides, cylinder wall, etc. Also examine the spark plug wire. Remove rubber boot and inspect internal spring for damage. Inspect spark plug wire for damage and be sure spring coil is securely attached to spark plug. **See following WARNING.**

▲ WARNING

- Remove spark plug wire to avoid accidental start up of the engine when servicing vehicle. To avoid ignition of fuel and serious personal injury or death, never try to start the engine with plug removed from engine.

Testing the Spark Plug

Check the sparking ability of a cleaned and properly gapped plug on a sparking comparator if possible. Spark should be blue and strong and able to jump a 5/16 inch (8 mm) gap.

Setting the Spark Gap

1. Before setting the spark gap on a used plug, pass a contact point file between the electrodes to produce flat, parallel surfaces to facilitate accurate gauging.
2. Use a wire type gauge. Bend the outside or ground electrode so only a slight drag on the gauge is felt when passing it between the electrode. Never make an adjustment by bending the center electrode. Set gap (A) to 0.027 to 0.031 in. (0.69 to 0.79 mm) (**Figure 13-5, Page 13-7**).

Spark Plug Installation

NOTE: Before installing the plug, check the condition of the threads in the cylinder head. Soften deposits in cylinder head threads with penetrating oil and clean the threads with a tap if necessary.

1. Install the spark plug and thread it in until finger tight, then tighten the spark plug to 20 ft-lb (27 N·m).

ENGINE MOUNTING PLATE

See Engine Removal on page 13-23.

CYLINDER HEAD

Read **DANGER** and **WARNING** on page 13-1.

GENERAL INFORMATION

Prior to attempting time-consuming repairs to the cylinder assembly, a cylinder compression test should be performed using a standard compression tester. Low compression would normally indicate a problem in the cylinder assembly such as defective rings, gaskets, etc. At a cranking speed of 550 - 600 RPM, the compression should be approximately 71 psi. **See following NOTE.**

NOTE: Key-start engines are equipped with an automatic compression release valve. This valve releases pressure at lower speeds, resulting in lower compression.

CYLINDER SHROUD REMOVAL

⚠ CAUTION

- Before removal and disassembly, clean the engine.
1. Access the engine compartment.
 2. Remove spark plug wire from spark plug.
 3. Loosen air intake hose clamp (7) from intake pipe (5) and remove hose (6) (**Figure 13-6, Page 13-9**).
 4. Disconnect the fuel line (9) and vent tube (10) from the carburetor (4) (**Figure 13-7, Page 13-9**).

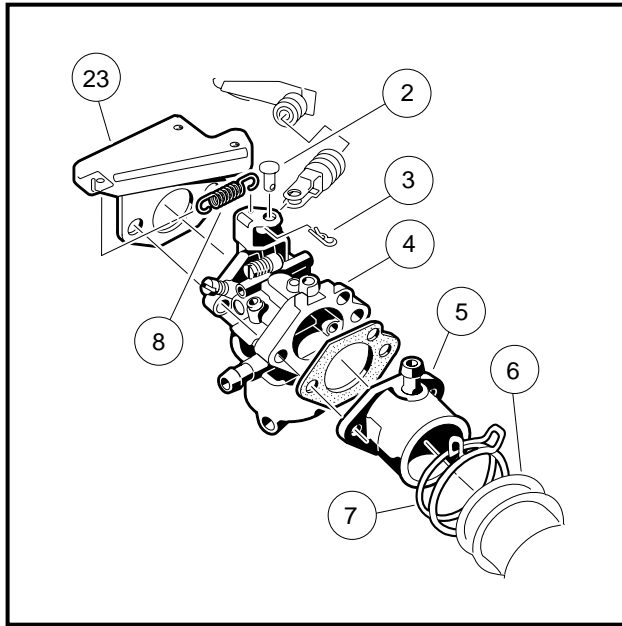

Figure 13-6 Carburetor Removal

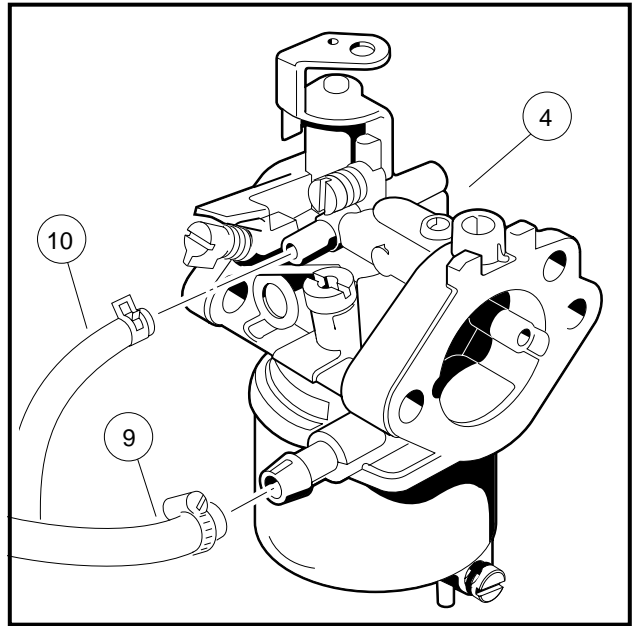

Figure 13-7 Carburetor, Fuel Line and Vent Line

▲ WARNING

- Plug fuel line to prevent gas from draining from line.
5. Remove cotter pin (3) and clevis pin (2) from throttle lever.
 6. Remove nuts at carburetor intake pipe (5) and remove intake pipe. **See following CAUTION.**

▲ CAUTION

- *Disconnect the governor linkage from the carburetor before attempting to remove the carburetor. Failure to do so could damage the linkage.*
7. Remove carburetor (4) along with throttle spring (8) and throttle spring bracket (23) (**Figure 13-6, Page 13-9**).
 8. Remove muffler. **See Section 15 – Exhaust System..**
 9. If the engine is to be totally disassembled, drain oil and remove the oil filter. If only the cylinder head is to be disassembled, proceed without draining the oil or removing the oil filter.
 10. Disconnect oil filler tube (20) from cylinder shroud by first removing the locknut (18), ground wire (17) and flange nut (10) and then pulling oil filler tube out of the crankcase cover (**Figure 13-8, Page 13-10**).

NOTE: Make sure vehicle is level before removing filler tube. This will prevent oil from spilling when filler tube is removed.

11. Remove the nine bolts (14) and two-ended bolt (11) (**Figures 13-8 and 13-9, Page 13-10**).
12. Take off the head shroud (13), the upper shroud (23) and the bracket (22).

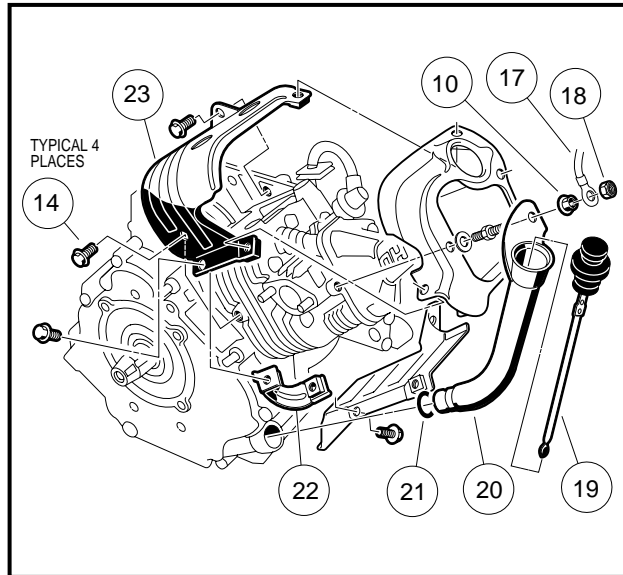

Figure 13-8 Upper Shroud and Oil Filler Removal

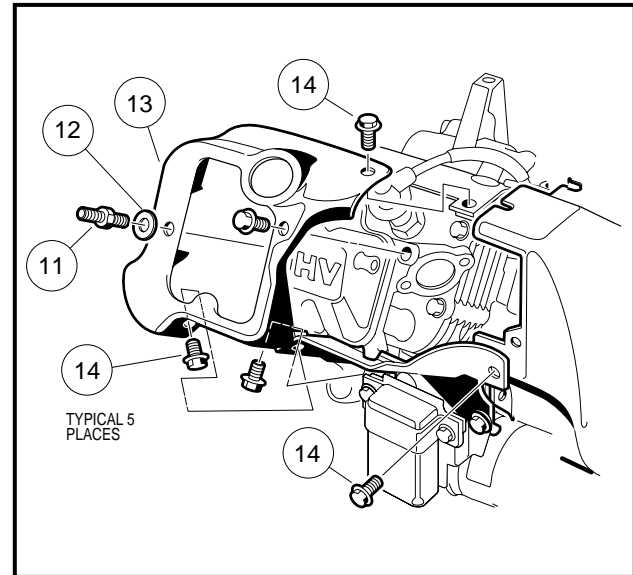

Figure 13-9 Head Shroud Removal

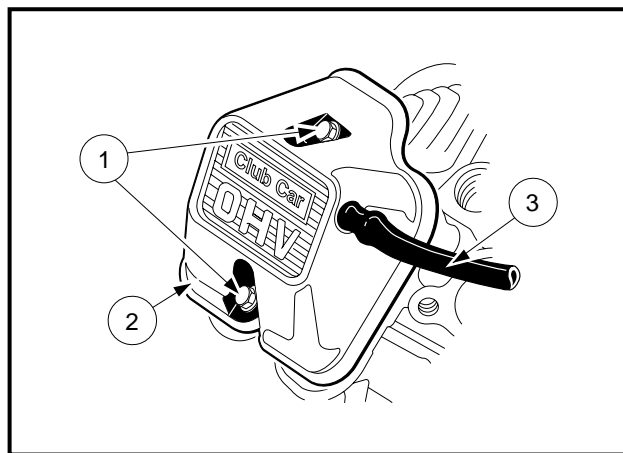

Figure 13-10 Remove Rocker Cover and Breather Tube

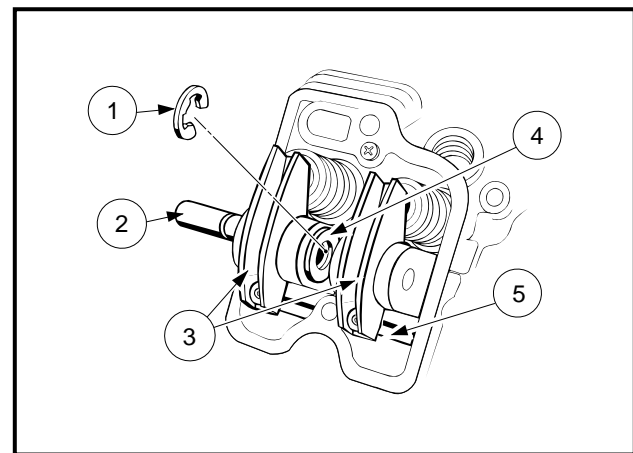

Figure 13-11 Remove Rocker Arms and Push Rods

ROCKER ARM AND PUSH ROD REMOVAL

NOTE: Because FE350 engines are equipped with hydraulic lifters, which automatically eliminate all clearance in the valve train, the rocker arms (3) and the push rods (5) do not need to be put back in their original positions (**Figure 13-11, Page 13-10**).

1. Remove the two bolts (1) and remove the rocker cover (2) along with the breather tube (3) (**Figure 13-10, Page 13-10**).
2. Remove the E-ring (1) and pull the rocker shaft (2) out of the cylinder head (**Figure 13-11, Page 13-10**).
3. Lift out the rocker arms (3), washer (4), and push rods (5).

CYLINDER HEAD REMOVAL

1. Remove the six bolts (1) and take off the cylinder head assembly (2) (**Figure 13-12, Page 13-11**).
2. Remove head gasket (3). Note the position of the two dowels (4) as shown (**Figure 13-13, Page 13-11**).

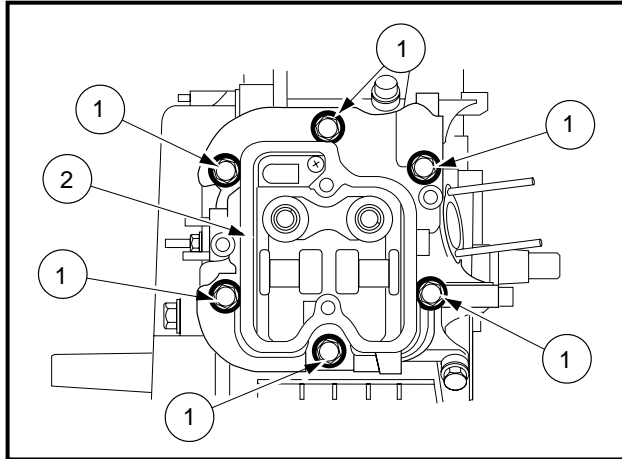

Figure 13-12 Remove Cylinder Head

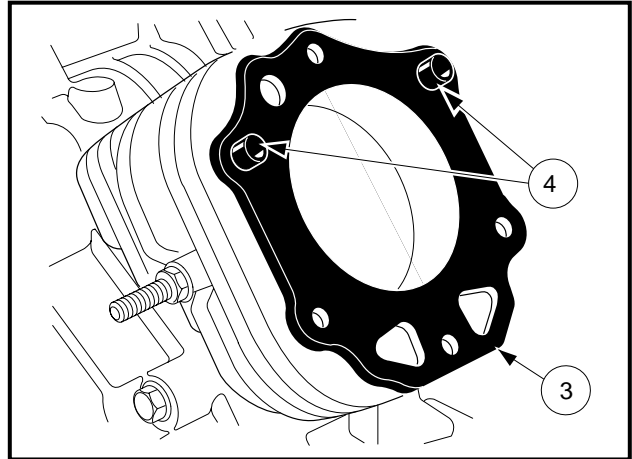

Figure 13-13 Remove Head Gasket

VALVE REMOVAL

1. Compress the valve spring with the valve spring compressor (5) (CCI 101641101) and remove the col-let halves (6) (**Figure 13-14, Page 13-11**).
2. Remove spring compressor, and take out the upper retainer (7) and the spring (8).
3. Remove valve (10).
4. Remove valve stem seal (11) with a screwdriver (**Figure 13-15, Page 13-11**). See following **CAUTION**.

▲ CAUTION

- To keep the screwdriver from damaging the cylinder head flange surface, place a piece of heavy cardboard or wood between them (**Figure 13-15, Page 13-11**).
- The valve stem seal cannot be reused. Replace valve stem seal with a new one.

5. Remove spring seat (9) (**Figure 13-15, Page 13-11**).

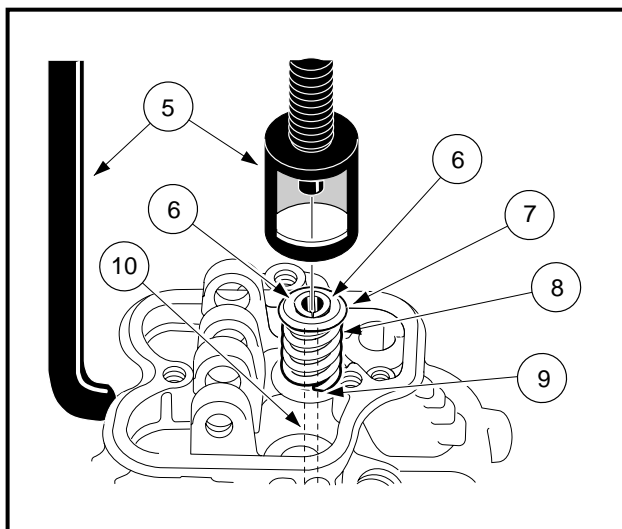

Figure 13-14 Valve Removal

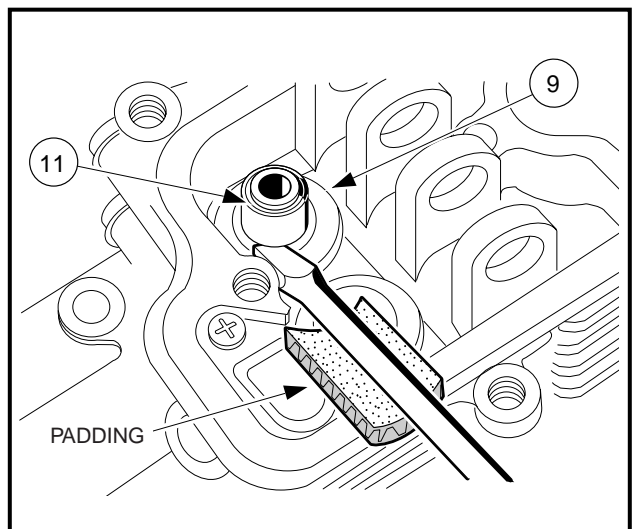

Figure 13-15 Spring Seat Removal

BREATHER VALVE (REED VALVE)

General Information

The function of the breather is to create a vacuum in the crankcase which prevents oil from being forced out of the engine through the piston rings, oil seals or gaskets.

The breather has a reed valve which limits the direction of air flow caused by the piston moving up and down. Air can flow out of the crankcase, but the one-way reed valve blocks return flow. It thus maintains a vacuum in the crankcase.

Oil laden air in the crankcase passes through the reed valve and expands into the rocker chamber. In the rocker chamber most oil separates from the air and drains back to the crankcase. The air passes through a tube and vents to the intake manifold.

Breather Valve (Reed Valve) Removal

1. Unscrew the mounting screw (1) and remove the back plate (2) and reed valve (3) (**Figure 13-16, Page 13-12**). See page 13-20 for Breather Valve Installation.

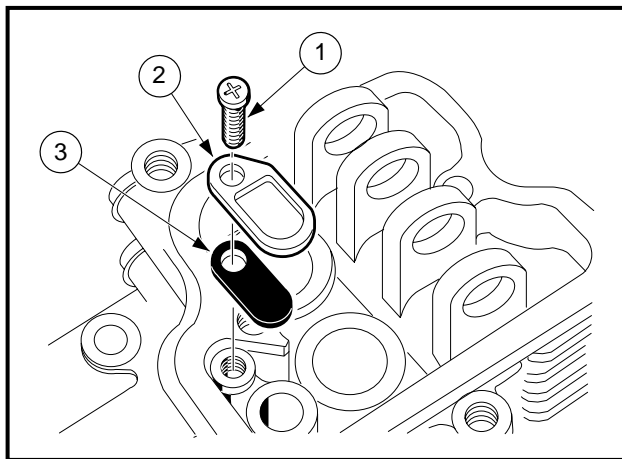

Figure 13-16 Reed Valve

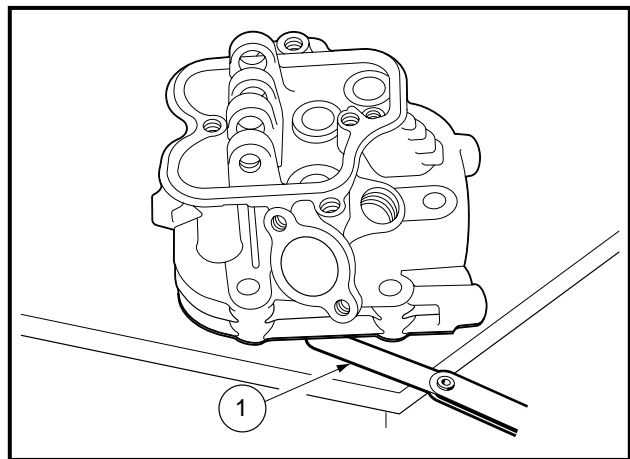

Figure 13-17 Check Flatness of Head Surface

CYLINDER HEAD CLEANING AND INSPECTION

1. Clean the head with a non-flammable solvent and dry thoroughly.
2. Bead blast or scrape carbon deposits from head. When scraping carbon deposits, be careful to avoid scratching or nicking the cylinder head.
3. Inspect the spark plug port threads for damage. If threads are damaged, replace the head.
4. Place the cylinder head on a surface plate (**Figure 13-17, Page 13-12**).
5. Measure the space between the surface plate and the head with a feeler gauge (1) to check the flatness of the head surface (**Figure 13-17, Page 13-12**).
6. If the head is warped more than 0.002 inch (0.05 mm), replace the head. **See following CAUTION.**

⚠ CAUTION

- Smooth out any damaged spots in the combustion chamber (1) using a small grinder. Sharp edges in the combustion chamber may cause pre-ignition. Do not remove any more material than is necessary or change the shape of the combustion chamber (**Figure 13-18, Page 13-13**).
- Do not grind the valve seats or the gasket surface.

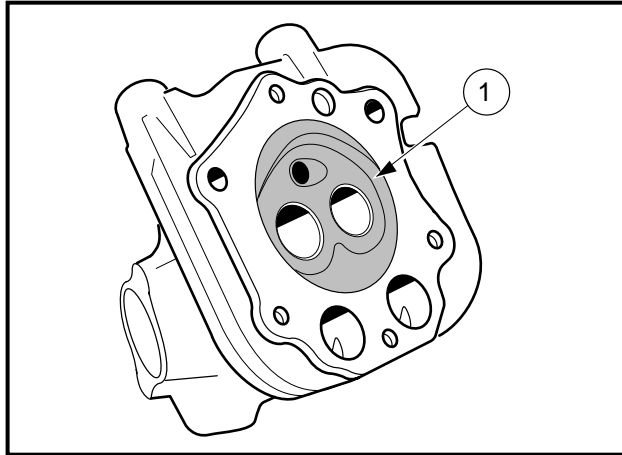

Figure 13-18 Combustion Chamber

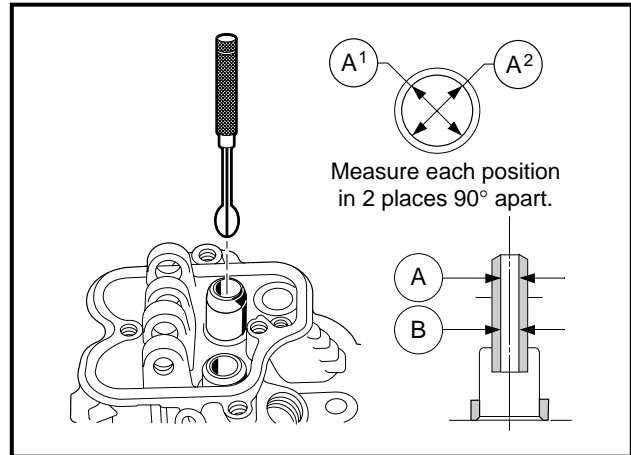

Figure 13-19 Measure I.D. of Valve Guides

VALVE GUIDES

Valve Guide Inspection

1. Measure the inside diameter of each guide with a telescoping gauge (**Figure 13-19, Page 13-13**).
2. If the inside diameter exceeds 0.2781 inch (7.065 mm), replace the guide.

Valve Guide Replacement

1. With the combustion chamber side of the head facing up, drive the guide out of the head with a valve guide arbor (1) (CCI 101641202) (**Figure 13-20, Page 13-14**).
2. Install the snap ring (2) on the new valve guide (**Figure 13-21, Page 13-14**).
3. Coat the guide with a light film of clean engine oil.
4. With the rocker arm side of the head facing up, drive the new valve guide into the head with the valve guide arbor (3) until the snap ring (2) just seats on the head (**Figure 13-21, Page 13-14**).
5. Ream the guide with a stanisol or kerosene lubricant and a valve guide reamer (CCI 101641201). The valve guide inside diameter should be 0.2756 - 0.2762 inch (7.000 - 7.015 mm) (**Figure 13-22, Page 13-14**).

VALVE SEATS

Valve Seat Inspection

1. Inspect the valve seats for damage. If the seats are warped or distorted beyond reconditioning, replace the cylinder head.
2. Using Prussian Blue, coat the valve seat.
3. Push the valve into the guide.
4. Rotate the valve against the seat with a lapping tool (1) (**Figure 13-23, Page 13-14**).

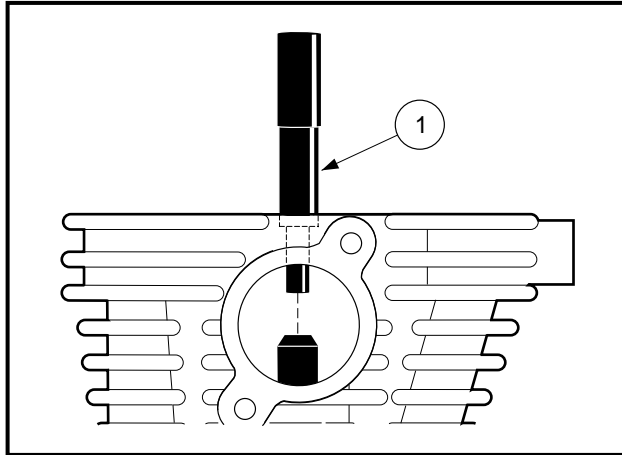

Figure 13-20 Valve Guide Removal

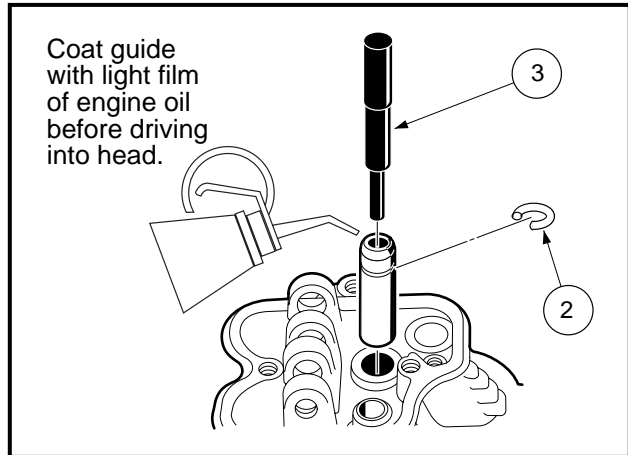

Figure 13-21 Valve Guide Installation

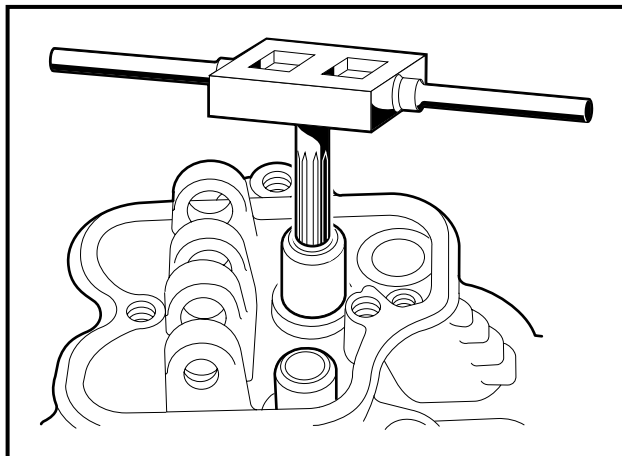

Figure 13-22 Ream Valve Guide

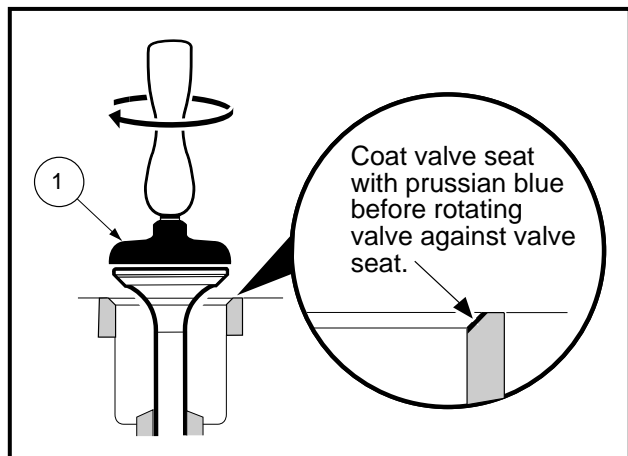

Figure 13-23 Rotate Valve against Valve Seat

5. Pull the valve out, and check the mark on the valve head. It must be 0.0197 - 0.0433 inch (.50 - 1.10 mm) in width, and even all the way around the seat and valve (**Figure 13-24, Page 13-15**).

NOTE: The valve stem and guide must be in good condition or step 5 will not be valid.

6. If the valve seating surface is not correct, repair the seat.
7. Pitted or worn valve seats can be resurfaced. **See Valve Seat Repair on page 13-14.** Make sure to lap the valves to the seats after refacing.

Valve Seat Repair

⚠ CAUTION

- If you are unfamiliar with the following procedures, Club Car suggests that the cylinder head be taken to a professional engine machine shop for reconditioning.

1. Clean the cylinder head thoroughly. **See Cylinder Head Cleaning and Inspection on page 13-12.**

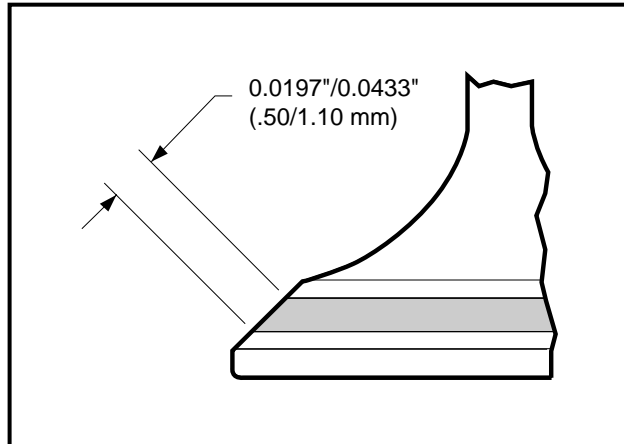

Figure 13-24 Check Mark on Valve Head

2. Recondition the valve seats with the valve seat cutters (45° x 35mm, 30° x 35mm) and lap the valves.
 - 2.1. Using Prussian Blue, check the seats for good contact all the way around. **See Valve Seat Inspection on page 13-13.**
 - 2.2. Measure the seat width of the 45° angle portion of the seat at several places around the seat (**Figure 13-25, Page 13-15**).
 - 2.3. If the seat width is more than 0.079 inch (2.0 mm), the seating surface should be resurfaced.
 - 2.4. Resurface the valve seat with a 45° (exhaust port) or a 30° (intake port) cutter (CCI 101655401), removing only enough material to produce a smooth and concentric seat (**Figure 13-26, Page 13-15**).

▲ CAUTION

- Use care not to dull the cutter. Do not turn the cutter counterclockwise or allow it to hit a metal object.

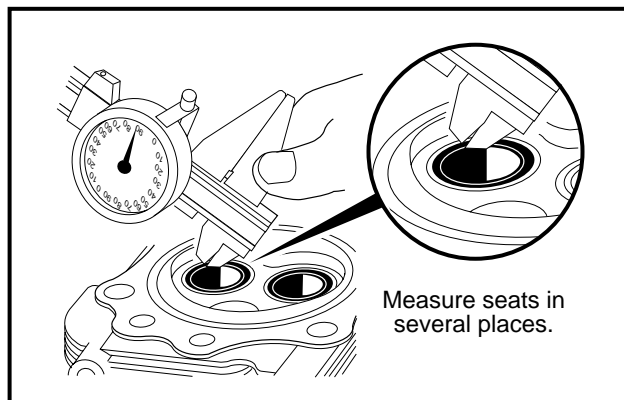

Figure 13-25 Measuring Valve Seats

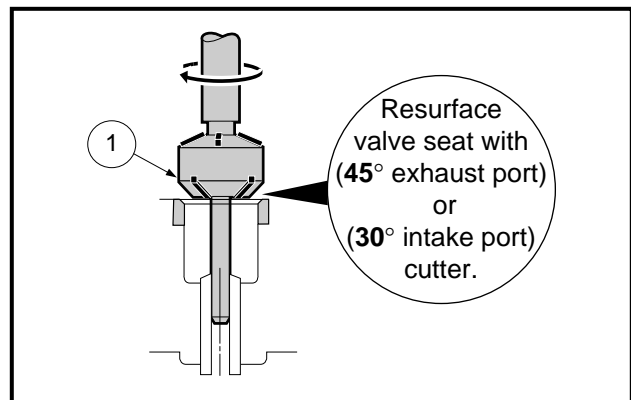

Figure 13-26 Resurfacing Valve Seat

- 2.5. Use a 60° x 35mm seat cutter (1) to narrow the seat width to the standard width.
- 2.6. Turn the seat cutter (1) clockwise one turn at a time while pressing down very lightly. Recheck the width after each cutter revolution. **See following CAUTION and NOTE.**

Valve Seat Repair, Continued:**⚠ CAUTION**

- The 60° seat cutter removes material very quickly. Check the seat outside diameter frequently to prevent over-cutting.

NOTE: Keep the seat width as close as possible to 0.031 inch (0.8 mm).

- 2.7. Make a light pass with the 45° cutter to remove any possible burrs at the edge of the seat.
3. After applying a coat of Prussian Blue to the valve face, insert the valve, and snap it closed against the seat several times. The valve surface should show good contact all the way around. Be sure the valve seat is centered on the valve face. The position of the valve in the seat is evident after lapping the valve.
4. If the seat does not make proper contact, lap the valve into the seat with a vacuum cup tool.
 - 4.1. Coat the surface of the valve sparingly with a fine lapping compound.
 - 4.2. Use the vacuum cup lapping tool (1) to grip the top of the valve. Rotate the valve in a circular motion to lap the valve to the seat (**Figure 13-27, Page 13-16**).
 - 4.3. Lift the valve slightly from the seat every 8 to 10 strokes, continuing the lapping operation until a uniform ring appears around the entire surface of the valve face.
5. When lapping is completed, wash all parts in solvent to remove lapping compound. Dry the parts thoroughly.
6. Note the position of the lapping mark on the valve face. The lapping mark should appear on or near the center of the face.

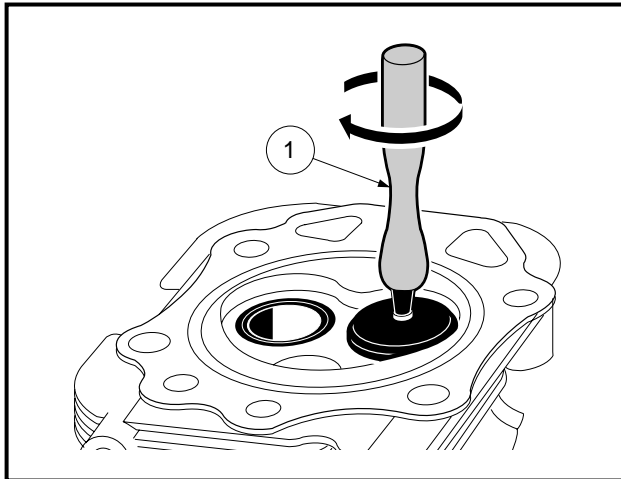

Figure 13-27 Lap Valve To Valve Seat

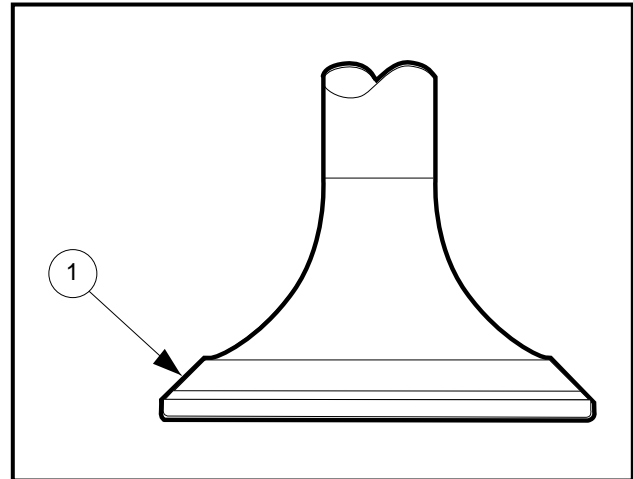

Figure 13-28 Valve Head Seating Area

VALVES**Visual Inspection of Valves**

1. Inspect the valve head seating area (1) for erosion, nicks and warping, etc. (**Figure 13-28, Page 13-16**). See following NOTE.

NOTE: The valve seating surface angle is 30° (intake), 45° (exhaust) (**Figure 13-29, Page 13-17**).

2. If the valve head seating area is worn, replace the valve.
3. If the valve head seating area is eroded or nicked, it may be possible to repair the valve on a valve refacing machine. Follow the refacing machine manufacturer's instructions.
4. Inspect the stem for obvious wear, discoloration, and stem end damage.
5. If the stem is obviously worn or discolored, replace the valve.

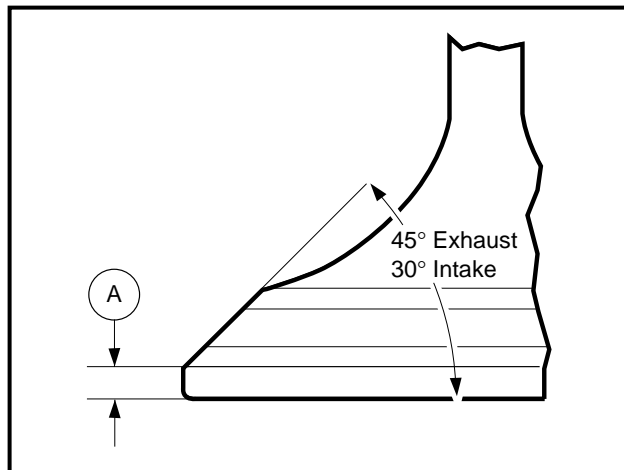

Figure 13-29 Valve Seating Surface Area

Valve Head Thickness

1. Measure the thickness of the valve head, as shown (**Figure 13-29, Page 13-17**).
2. If the valve head thickness (A) (**Figure 13-29, Page 13-17**) is less than 0.024 inch (0.610 mm), replace the valve.

Valve Stem Bend

1. Support the valve in V-blocks at each end of the stem (**Figure 13-30, Page 13-18**).
2. Position a dial gauge perpendicular to the stem.
3. Turn the valve and read the variation on the dial gauge.
4. If stem bend is greater than the service limit of 0.0012 inch (0.0305 mm), replace the valve.

Valve Stem Diameter

1. Using a micrometer, measure the diameter of the stem at several points along its length (**Figure 13-31, Page 13-18**).
2. If the outside diameter is less than the service limit of 0.2728 inch (6.930 mm) intake, 0.2722 inch (6.915 mm) exhaust, replace the valve.

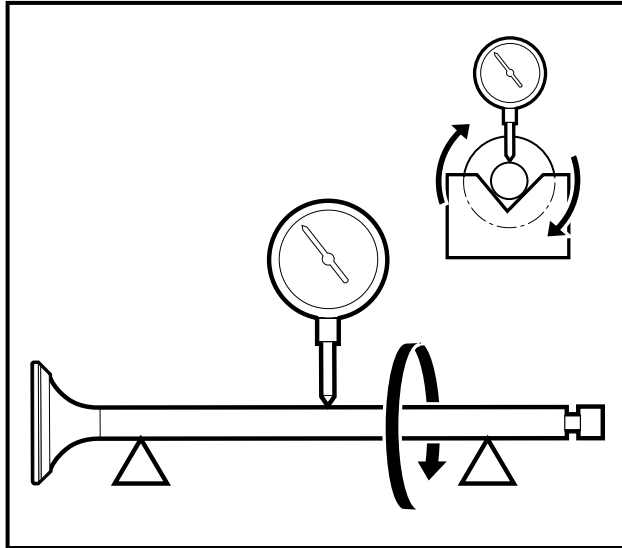

Figure 13-30 Measure Valve Stem Bend

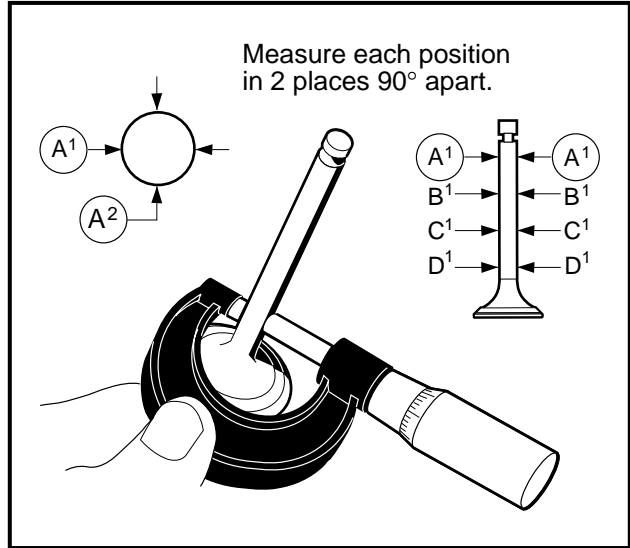

Figure 13-31 Measure Valve Stem Diameter

Valve Spring Inspection

1. Inspect the valve springs (1) for pitting, cracks, corrosion and burrs. Replace the springs if necessary (Figure 13-32, Page 13-18).
2. Measure the free length of the spring. If the measurement is less than the service limit of 1.51 inch (38.50 mm), replace the spring (Figure 13-32, Page 13-18).

ROCKER ARM AND ROCKER SHAFT INSPECTION

1. Using a dial bore or telescoping gauge, measure the inside diameter of each rocker arm bearing at several points along its length (Figure 13-33, Page 13-18).
2. If the inside diameter is more than the service limit of 0.4803 inch (12.20 mm), replace the rocker arm.
3. Using a micrometer, measure the diameter of the rocker shaft at several points along its length (Figure 13-34, Page 13-19).
4. If the outside diameter is less than the service limit of 0.4704 inch (11.949 mm), replace the shaft.

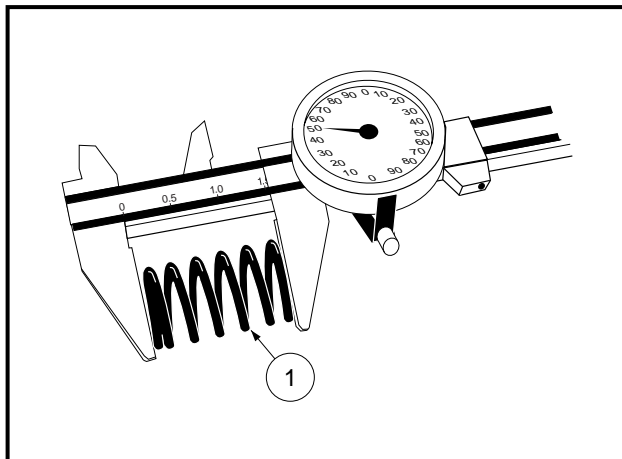

Figure 13-32 Measure Valve Spring Length

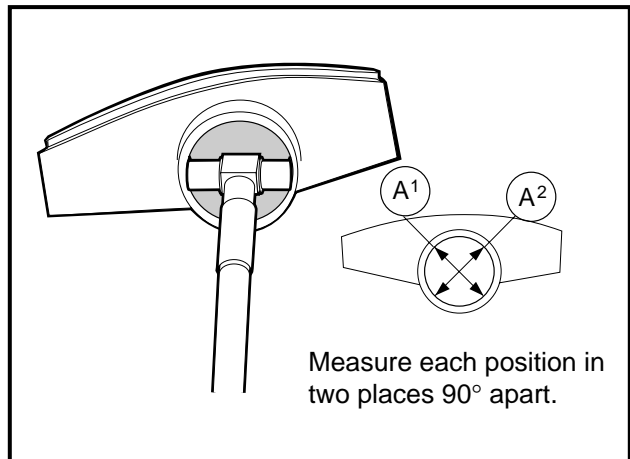

Figure 13-33 Measure Rocker Arm Bearing I.D.

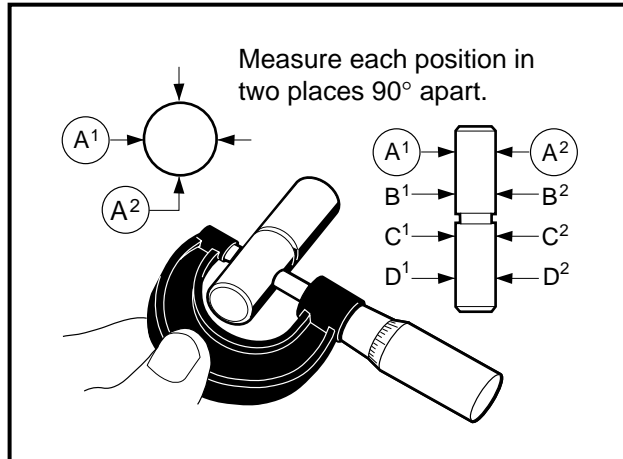

Figure 13-34 Measure Rocker Shaft I.D.

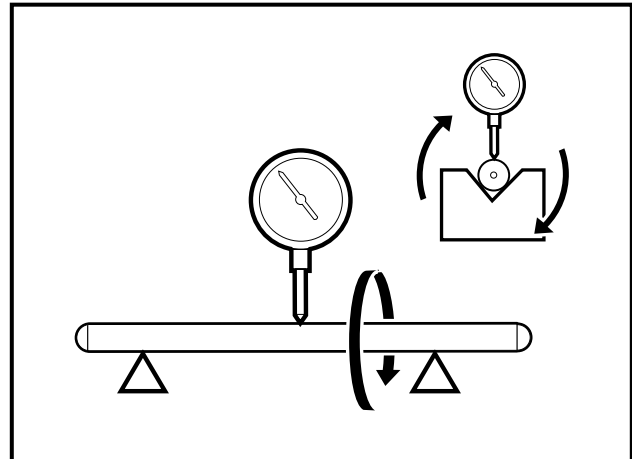

Figure 13-35 Check For Push Rod Distortion

PUSH ROD INSPECTION

1. Support the rod in V blocks at each end of the rod. Position a dial gauge perpendicular to the rod (**Figure 13-35, Page 13-19**).
2. Turn the rod slowly and read the variation on the gauge.
3. If the push rod is bent more than 0.019 inch (0.5 mm), replace the push rod.

CYLINDER HEAD INSTALLATION

Read **DANGER** and **WARNING** on page 13-1.

1. Installation is the reverse of removal. **See Cylinder Head Removal on page 13-10.**
2. Making sure that each push rod (5) is in place between the rocker arm (3) and the hydraulic lifter as shown, put the rocker shaft (2) into the posts through the rocker arm (3) and washer (4) (**Figure 13-36, Page 13-20**).
3. Slide the washer (4) against the exhaust rocker, and fit the E-ring (1) into the groove in the rocker shaft (2) (**Figure 13-36, Page 13-20**).
4. Install cylinder head assembly to engine.
5. Tighten the bolts down evenly by hand.
6. Using a torque wrench, tighten the six bolts in the sequence shown (**Figure 13-37, Page 13-20**).
7. Increase the torque in four increments of 50 in-lb (6 N·m) and then tighten to final torque of 220 in-lb (25 N·m). **See following CAUTION.**

CAUTION

- Do not turn any one bolt down completely before tightening the others. Doing so may cause the cylinder head to warp.

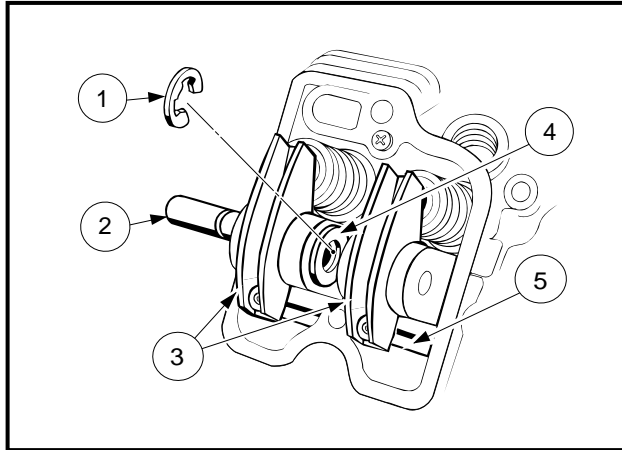

Figure 13-36 Cylinder Head Assembly

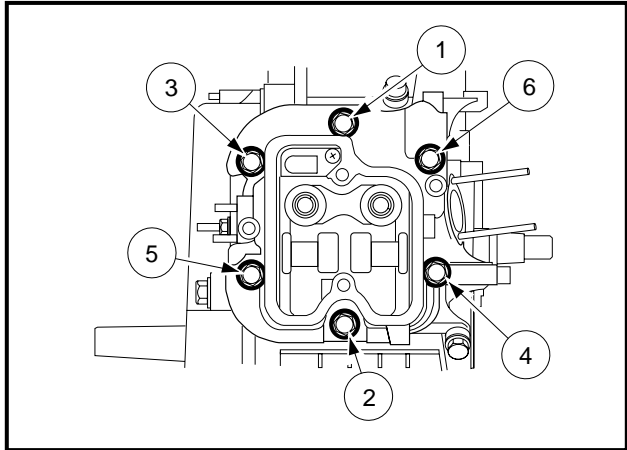

Figure 13-37 Cylinder Head Bolt Tightening Sequence

VALVE CLEARANCE CHECK AND ADJUSTMENT

No clearance check and no clearance adjustments are required. The FE350 engine is equipped with hydraulic lifters that automatically eliminate all clearance in the valve train components.

BREATHER VALVE (REED VALVE)

General Information

The function of the breather is to create a vacuum in the crankcase which prevents oil from being forced out of the engine through the piston rings, oil seals or gaskets.

The breather has a reed valve which limits the direction of air flow caused by the piston moving up and down. Air can flow out of the crankcase, but the one-way reed valve blocks return flow. It thus maintains a vacuum in the crankcase.

Oil laden air in the crankcase passes through the reed valve and expands into the rocker chamber. In the rocker chamber most oil separates from the air and drains back to the crankcase. The air passes through a tube and vents to the intake manifold.

Breather Valve Inspection

1. Inspect the reed valve (1) for sticking or binding. Replace if necessary (**Figure 13-38, Page 13-21**).
2. Inspect the reed valve for hairline cracks, distortion or breakage. Replace if necessary.
3. Inspect the reed valve (1) seating surface. It must not have any nicks or burrs.

Breather Valve Installation

1. Installation is the reverse of removal. **See Breather Valve (Reed Valve) Removal on page 13-12.**

NOTE: Place the reed valve on the seat so there is a slight gap (2) 0.008 inch maximum (0.203 mm) between the valve and the seat (**Figure 13-38, Page 13-21**).

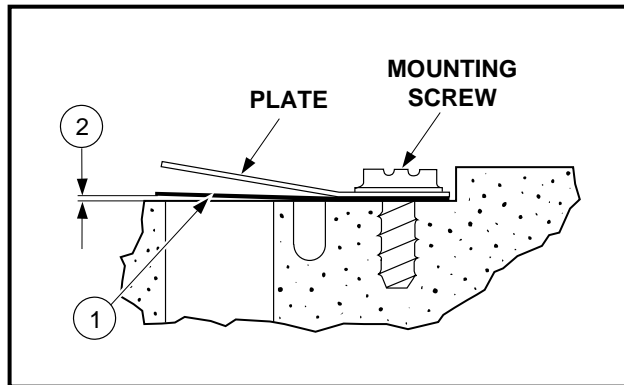

Figure 13-38 Reed Valve

INSTALLATION OF REMAINING ENGINE COMPONENTS

1. Install rocker cover.
2. Install lower, upper, and head shrouds (1) along with two-ended bolt (2) (**Figure 13-39, Page 13-22**).

NOTE: The shorter end of the two-ended bolt (2) goes through washer and upper shroud.

To prevent leaks, apply a light coat of clean engine oil to the O-ring seal (7) before installation. Care should be taken during installation to avoid cutting or nicking the O-ring seal (**Figure 13-39, Page 13-22**).

3. Install oil filler tube (6) and O-ring (7) into the large hole in the crankcase cover. Install the upper end of the oil filler tube (6) onto the two-ended bolt (2). Install flange nut (8) and tighten to 50 in-lb (5.7 N·m). Connect the ground wire (3) to the two-ended bolt and install and tighten the nylon locknut (4) to 50 in-lb (5.6 N·m). Insert the dip stick (5) (**Figure 13-39, Page 13-22**).
 4. Connect muffler. **See Section 15 – Exhaust System.**
 5. Install carburetor (11), throttle spring (12) and the throttle spring bracket (13). Tighten to 50 in-lb (5.6 N·m) (**Figure 13-40, Page 13-22**).
 6. Connect fuel lines. **See Section 14 – Fuel System.** Tighten fuel line hose clamp at the carburetor to 9 in-lb (1.0 N·m) (**Figure 13-7, Page 13-9**).
 7. Install the spark plug and thread it in until finger tight, then tighten the plug to 20 ft-lb (27 N·m).
- NOTE:** Before installing the plug, check the condition of the threads in the cylinder head. Soften deposits in cylinder head threads with penetrating oil and clean the threads with a tap if necessary.
8. Install governor cable clevis pin (9) through cable clevis and throttle valve, and install a new cotter pin (10).
 9. Apply a light film of clean engine oil onto the seal of the new oil filter and install the filter. Tighten the filter 2/3 turn after gasket contact. Fill crankcase with the correct level of oil (**Figure 13-41, Page 13-22**). **See Section 2 – Vehicle Specifications.**
 10. Run the engine for three minutes to check for leaking oil.

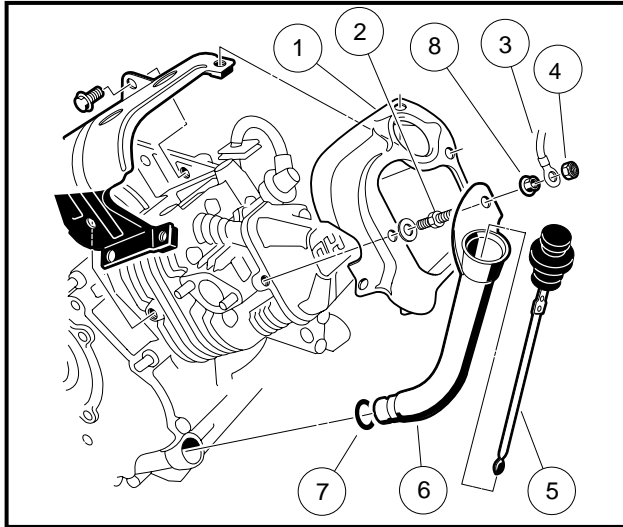

Figure 13-39 Oil Filler Tube and Ground Wire

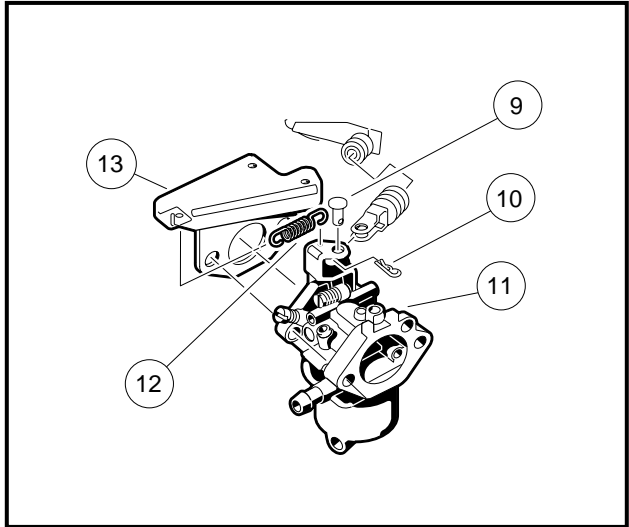

Figure 13-40 Governor Cable Connection

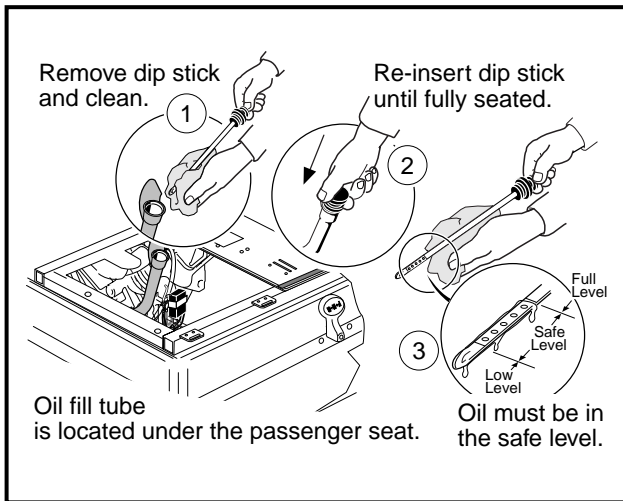

Figure 13-41 Check Engine Oil Level

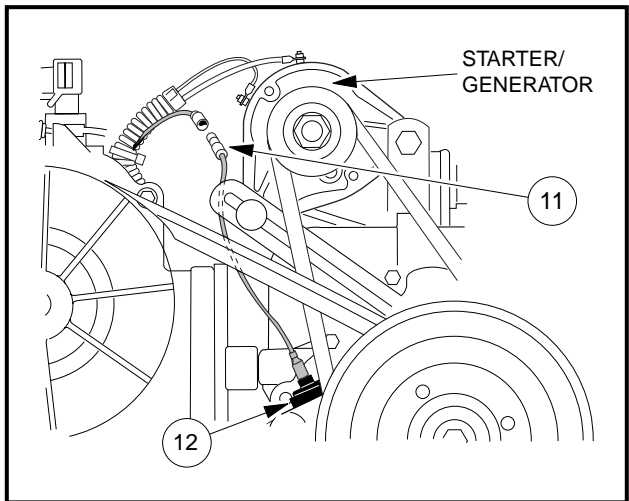

Figure 13-42 Oil Level Sensor Wire

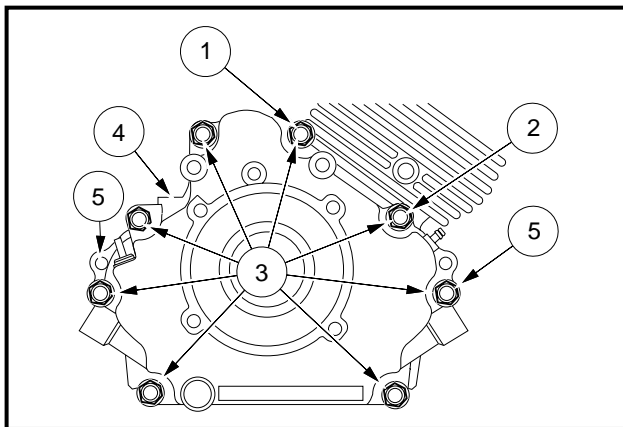

Figure 13-43 Crankcase Cover

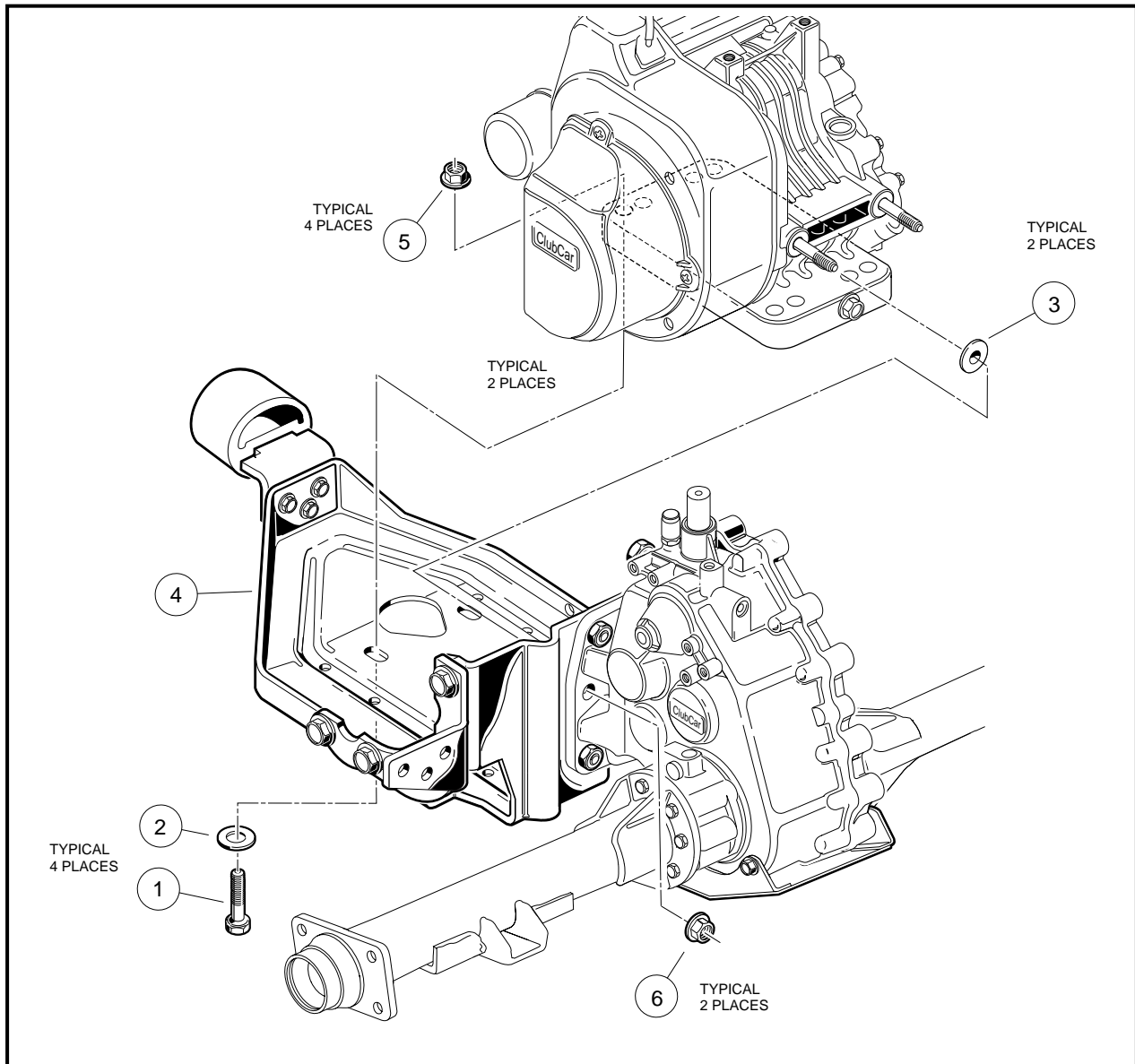

Figure 13-44 Engine Mounting Plate

CRANKCASE

Read **DANGER** and **WARNING** on page 13-1.

ENGINE REMOVAL

To perform repairs on crankcase components, the engine must be removed from the vehicle.

▲ CAUTION

- Before removal and disassembly, clean the engine.

1. Remove the powertrain by performing steps 1 through 14, pages 16-7 through 16-14 in Section 16 – Unitized Transaxle with Differential Lock. **See following NOTE.**

Engine Removal, Continued:

2. Remove starter-generator. **See Section 12 – Electrical Components.**
3. Remove drive clutch. **See Section 17 – Torque Converter. See also following NOTE.**

NOTE: The crankshaft has left-hand threads at the clutch mounting hole.

4. Remove muffler. **See Section 15 – Exhaust System.**
5. Remove engine mounting hardware (Items 1, 2, 5 and 6) **(Figure 13-44, Page 13-23).**
6. Lift engine from the mounting plate.
7. Remove crankcase oil drain plug and filler tube. Tip the engine slightly to allow all of the oil to drain from the crankcase. Dispose of engine oil properly.

CRANKCASE COVER REMOVAL

1. Remove yellow jumper wire (11) from cord connector (12) **(Figure 13-42, Page 13-22).**
2. Remove nuts and clamps at two-ended bolts (1 and 2) **(Figure 13-43, Page 13-22).**
3. Remove eight bolts (3) and remove the crankcase cover (4) **(Figure 13-43, Page 13-22). See following NOTE.**

NOTE: If the crankcase cover sticks, tap lightly with a plastic mallet on alternate sides near the dowel pins (5) **(Figure 13-43, Page 13-22).**

4. Remove the crankcase cover gasket completely. It may stick to the flanged surface of the crankcase.

OIL LEVEL SENSOR**Testing the Oil Level Sensor**

See Test Procedure 21, Section 11, Page 11-38.

Oil Level Sensor Removal

1. If not already removed, remove crankcase cover. **See Crankcase Cover Removal on page 13-24.**
2. Disconnect the oil level sensor wire (2) from the cord connection (1) **(Figure 13-45, Page 13-25).**
3. Remove the screw (3) from the wire clamp (4).
4. Remove the two mounting screws from the inside of the crankcase cover and remove the oil level sensor and bracket.
5. If necessary, remove the three screws (7) that hold the sensor to the bracket (5).

Oil Level Sensor Installation

1. If the oil level sensor was removed from the bracket, install sensor (6) into bracket (5) and secure with three screws (7) **(Figure 13-45, Page 13-25).** Tighten to 17 in-lb (1.9 N·m).
2. Position the sensor and bracket on inside of crankcase and install two mounting screws.
3. Connect sensor wire (2) to cord connector (1) **(Figure 13-45, Page 13-25).**
4. Install screw (3) through wire clamp and into crankcase cover. Tighten to 30 in-lb (3.4 N·m).

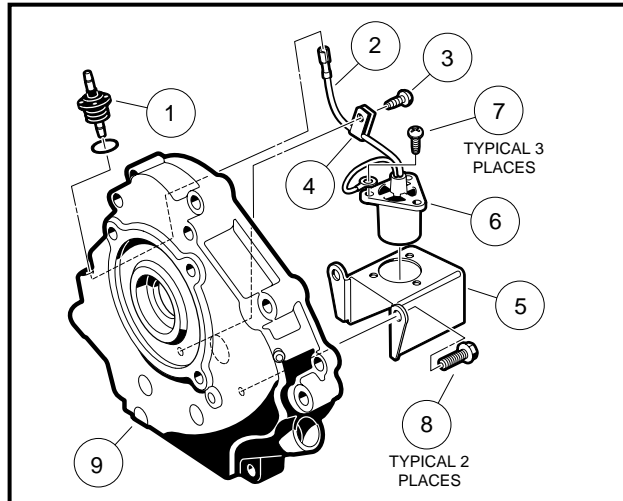

Figure 13-45 Oil Level Sensor

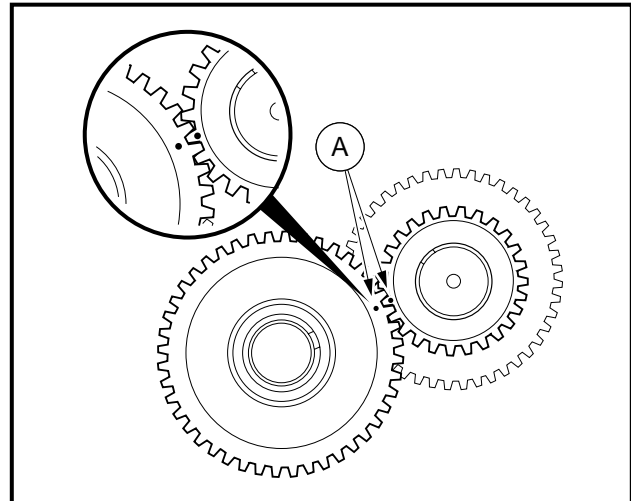

Figure 13-46 Timing Mark Alignment

CAMSHAFT AND HYDRAULIC LIFTERS

Camshaft and Hydraulic Lifter Removal

1. Keep the timing marks (A) aligned during removal (**Figure 13-46, Page 13-25**).
2. With cylinder head removed, pull the hydraulic lifters out of their bores to the top of the cylinder. **See following CAUTION. See Cylinder Head on page 13-8.**
3. Take the camshaft out of the engine block.

CAUTION

- Do not depress the socket (1) (**Figure 13-47, Page 13-26**). This will cause the engine oil to leak out of the high pressure chamber during storage. Keep the hydraulic lifters upright to prevent the engine oil from spilling out of the lifters during storage.
- Do not attempt to disassemble a hydraulic lifter because the engine oil will drain out of the high pressure chamber in the lifter.

Camshaft and Hydraulic Lifter Inspection

If the engine typically remains noisy for two minutes after it starts, the hydraulic lifter might be worn between the plunger (2) and the body (3). Proceed with the following to check the hydraulic lifter for wear (**Figure 13-47, Page 13-26**).

1. Put the hydraulic lifter vertically on a measuring stand to measure leak-down distance.
2. Push the socket (1) down and measure the distance that it sinks (**Figure 13-47, Page 13-26**).
3. If the distance exceeds 0.0197 inch (0.5 mm), replace both hydraulic lifters as a set.
4. Inspect the camshaft for wear or broken gear teeth.
5. Measure the camshaft journals and cam lobes with a micrometer at the points shown (**Figure 13-48, Page 13-26**) and (**Figure 13-49, Page 13-26**).
6. If the camshaft journal diameter is less than 0.9026 inch (22.927 mm) at either end of the shaft, replace the camshaft.

7. If the lobe height is less than 1.3086 inches (33.24 mm) for either lobe, replace the camshaft.
8. Check the automatic compression release valve (ACR) arms to make sure they move freely and are not binding. Clean the arms if needed. Make sure the take-up spring is properly installed. Replace the spring if it is broken. If the arms are damaged, the camshaft assembly must be replaced.

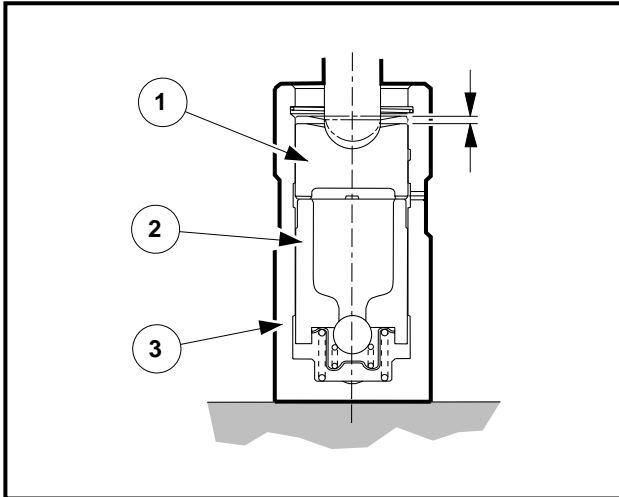

Figure 13-47 Inspect for Hydraulic Lifter Wear

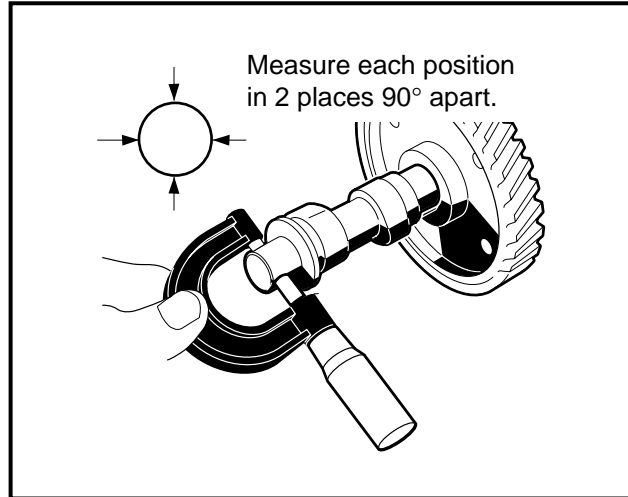

Figure 13-48 Measure O.D. of Camshaft Journals

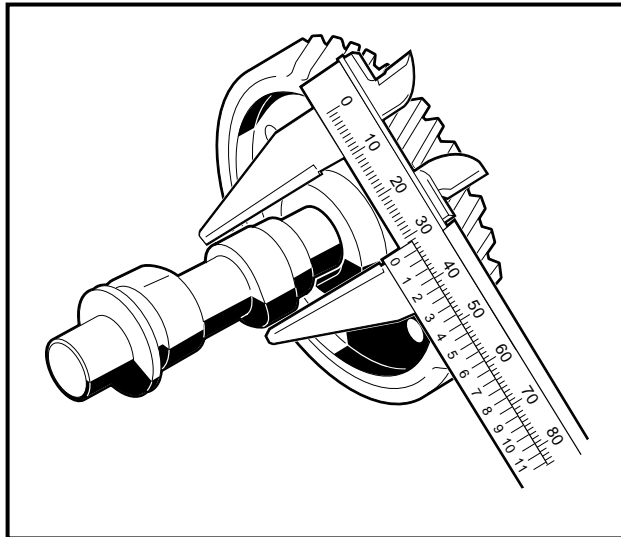

Figure 13-49 Measure O.D. of Cam Lobes

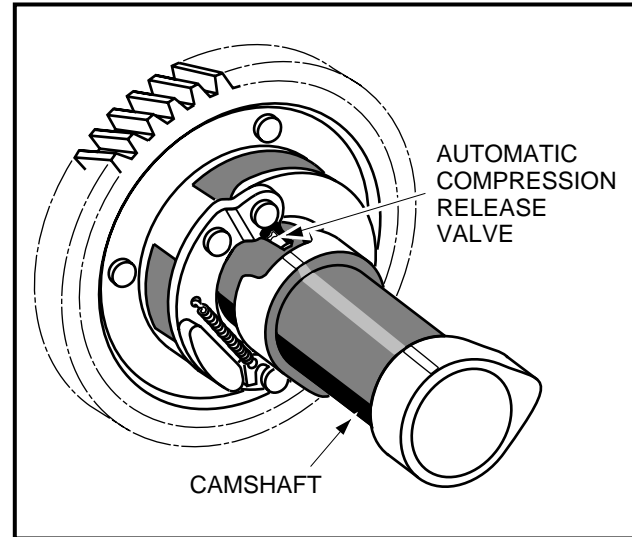

Figure 13-50 ACR Valve Inspection

Automatic Compression Release Valve (ACR) Inspection

Pioneer FE350 engines have an automatic compression release valve (ACR) that is activated during the starting procedure (**Figure 13-50, Page 13-26**). As the engine is cranked, the ACR opens and reduces compression in the cylinder, allowing the starter to turn the engine with a minimal amount of effort. When the engine starts and accelerates, the ACR closes and full compression is reached. Because the ACR reduces compression during the cranking cycle, starter/generator brush life is greatly extended.

The engine cranks at 550 to 650 RPM and the ACR closes at approximately 700 RPM. After the engine starts, it will idle at 1050 to 1150 RPM.

When the engine is cranked by the starter, a tapping noise will be heard while the ACR is in an open condition. It is a normal function of the ACR to click, or tap, as the engine cranks at a speed below 700 RPM. After the engine starts and begins to idle, the ACR will close and the tapping noise will stop.

If the ACR fails to hold the valve open during the cranking function, the engine will have too much compression and may not turn over when the starter is activated. If the ACR fails to allow the exhaust valve to close, the engine will not reach full compression and will not have complete acceleration power. The return spring is the only serviceable part on the ACR. The ACR is a component part of the camshaft assembly and as such, if the ACR fails, the camshaft assembly must be replaced.

PISTON AND CONNECTING ROD

Read **DANGER** and **WARNING** on page 13-1.

NOTE: The connecting rod and cap must stay together as a set. Do not mix with parts from any other engine.

Piston and Connecting Rod Removal

1. Turn crankshaft to expose the two connecting rod cap bolts (1) (**Figure 13-51, Page 13-27**).
2. Loosen the cap bolts and take them out together with the connecting rod cap (2).
3. With cylinder head removed, push the piston/connecting rod assembly out of the cylinder.

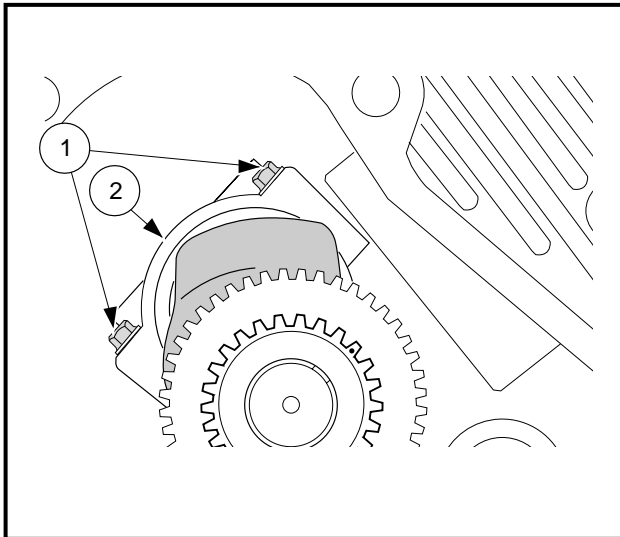

Figure 13-51 Connecting Rod Cap Bolts

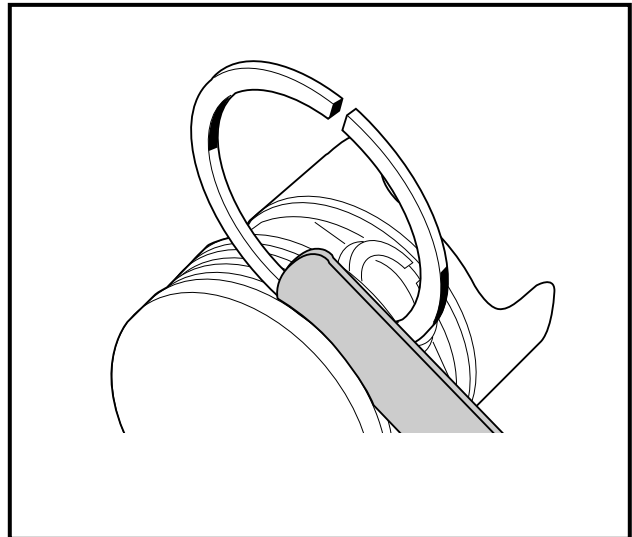

Figure 13-52 Measure Piston Ring and Groove Clearance

Piston and Connecting Rod Separation

1. Remove two retaining rings holding the piston pin in place.
2. Remove the piston pin.

Piston Inspection and Repair

1. Remove all deposits from the piston.
2. Clean the carbon from the piston ring grooves. **See following CAUTION.**

⚠ CAUTION

- *Never clean the piston head with the engine assembled. Carbon particles will fall between the piston and cylinder wall and may cause severe cylinder wear.*
3. Be sure the oil return passages in the ring grooves are open.
 4. Visually inspect the piston rings and ring grooves for uneven wear or damage. Replace the piston and/or piston rings if uneven wear or damage is present or if they exceed the wear limits.
 5. Using a new piston ring and a feeler gauge, measure the clearance between the grooves and ring at several points around the grooves (**Figure 13-52, Page 13-27**).
 6. If the top groove has a clearance greater than 0.0063 inch (0.16 mm), replace the piston.
 7. If the second groove has a clearance greater than 0.0055 inch (0.14 mm), replace the piston.
 8. The oil ring is made of three pieces: upper and lower rails and expander. It is difficult to measure the ring groove clearance and thickness. Inspect visually for wear or damage.

Piston Ring Inspection

1. Insert the ring squarely into the cylinder bore to a point approximately 1 inch (25 mm) down from the top the cylinder. **See following NOTE.**

NOTE: Use the top of the piston to push the ring into the bore to be sure it is square.

2. Using a feeler gauge, measure the ring end-gap (**Figure 13-53, Page 13-28**).
3. If the end-gap of any ring is greater than 0.0472 inch (1.199 mm), replace the entire set of rings.
4. Using a micrometer, measure the thickness of both piston rings at several points around the rings (**Figure 13-54, Page 13-28**).
5. If either ring thickness is less than 0.0566 inch (1.438 mm), replace the entire set of rings.

NOTE: It is difficult to measure exactly the oil ring thickness. Replace the oil ring whenever the compression rings (top and second) are replaced.

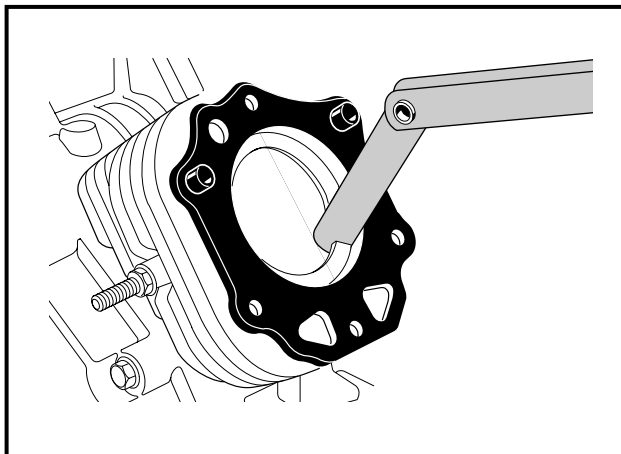

Figure 13-53 Measure Ring End-Gap

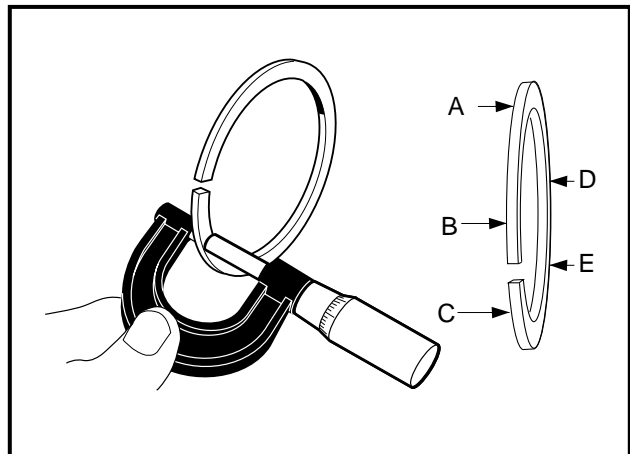

Figure 13-54 Measure Piston Ring Thickness

Piston Pin Inspection

1. Using a micrometer, measure the outside diameter of the piston pin at several points along its length (**Figure 13-55, Page 13-29**).
2. If the pin diameter is smaller than 0.7864 inch (19.975 mm), replace the piston pin.
3. Using an inside micrometer or telescoping gauge, measure the inside diameter of the piston pin hole in the piston at several points (**Figure 13-56, Page 13-29**).
4. If the inside diameter exceeds 0.7887 inch (20.033 mm), replace the piston.

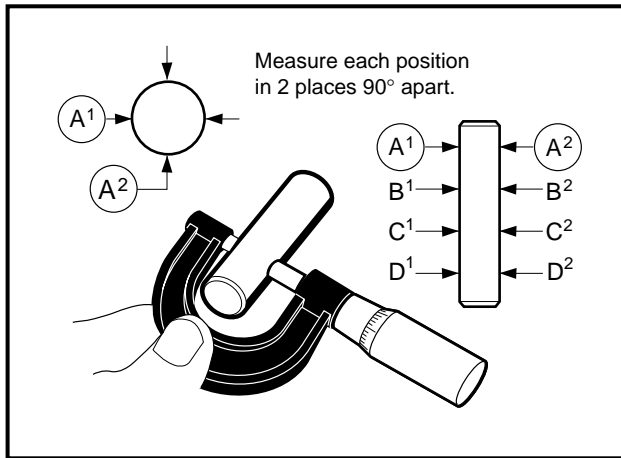

Figure 13-55 Measure Piston Pin O.D.

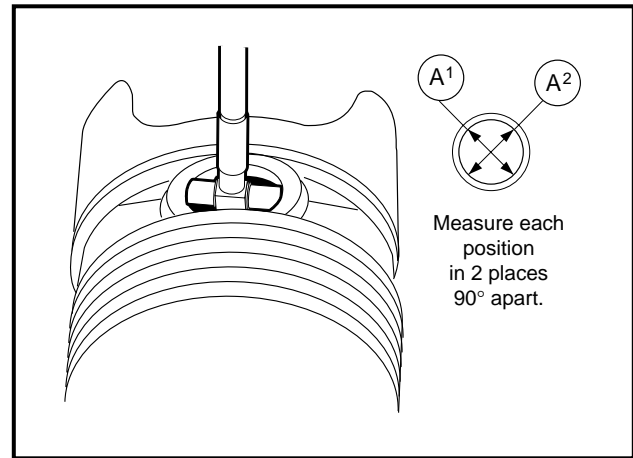

Figure 13-56 Measure Piston Pin Hole I.D.

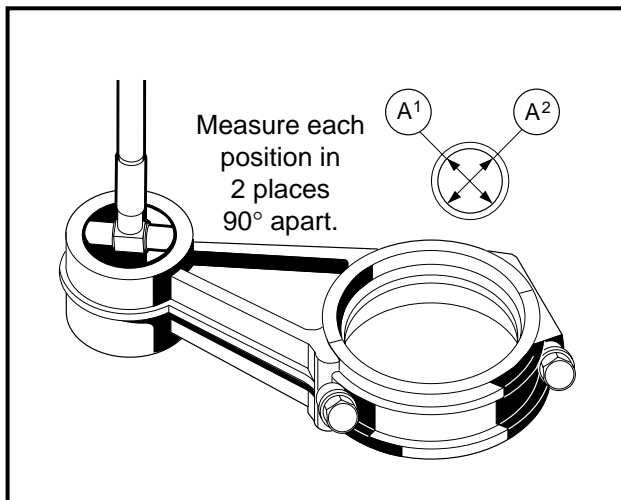

Figure 13-57 Measure Connecting Rod Small Bore I.D.

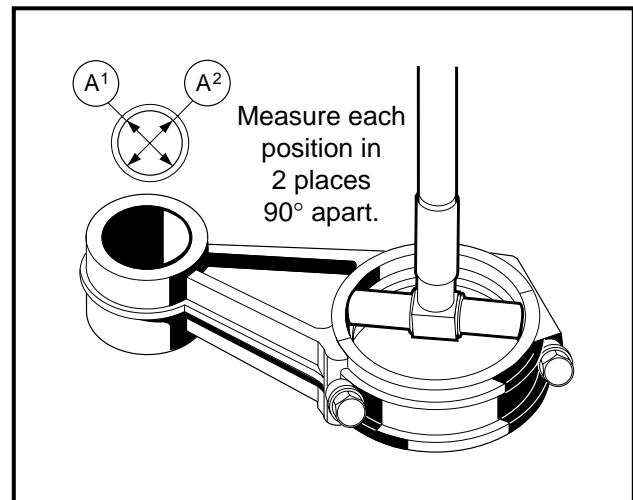

Figure 13-58 Measure Connecting Rod Large Bore I.D.

Connecting Rod Inspection

1. Clean and inspect the bearing surfaces of the connecting rod and cap. Replace parts if scored.
2. Using a telescoping gauge, measure the inside diameter of the connecting rod small bore at several points along its length (**Figure 13-57, Page 13-29**).
3. If the inside diameter exceeds 0.7887 inch (20.033 mm), replace the connecting rod.
4. Remount the connecting rod cap to the connecting rod at the large bore end, aligning the pilot groove on the rod. Screw in the connecting rod bolts and tighten them to 16.5 ft-lb (23 N·m).

Connecting Rod Inspection, Continued:

- Using a telescoping gauge or an inside micrometer, measure the inside diameter of the large bore at several points along its length (**Figure 13-58, Page 13-29**).
- If the inside diameter exceeds 1.479 inches (37.567 mm), replace the connecting rod. **See following NOTE.**

NOTE: If the connecting rod is bent or twisted, it must be replaced.

The connecting rod and cap must stay together as a set. Do not mix with parts from any other engine.

CYLINDER BLOCK**Read DANGER and WARNING on page 13-1.**

While the engine is disassembled, inspect the cylinder block for cracks, stripped bolt holes, broken fins, or cylinder wall scoring. Repair or replace as necessary.

- Use an inside micrometer or telescoping gauge, together with a micrometer, to measure the cylinder bore.
- Make the first measurement parallel with the crankshaft and the second at right angles to the crankshaft at three different locations in the bore. The first measurement location is 0.4 inch (10 mm) from the top of the cylinder. The second location is in the center or 2.4 inches (60 mm) from the top, and the third location is 0.3 inch (8 mm) from the bottom of the cylinder or bottom of ring travel. See locations 1, 2, and 3 (**Figure 13-59, Page 13-30**).
 - The standard bore diameter is 3.2669 - 3.2677 inches (82.980 - 83.000 mm).
 - The maximum cylinder bore diameter wear limit is 3.2703 inches (83.067 mm).
 - The maximum acceptable out of round cylinder bore is 0.0022 inch (0.056 mm).
- If the cylinder bore is not within these measurements, the cylinder bore will need to be resized.

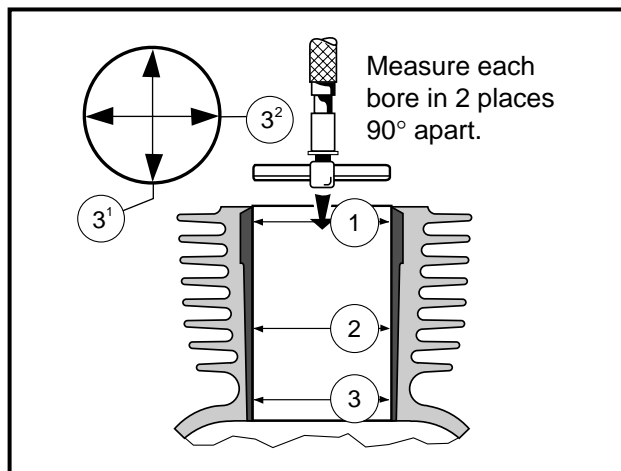

Figure 13-59 Measure Cylinder Bore

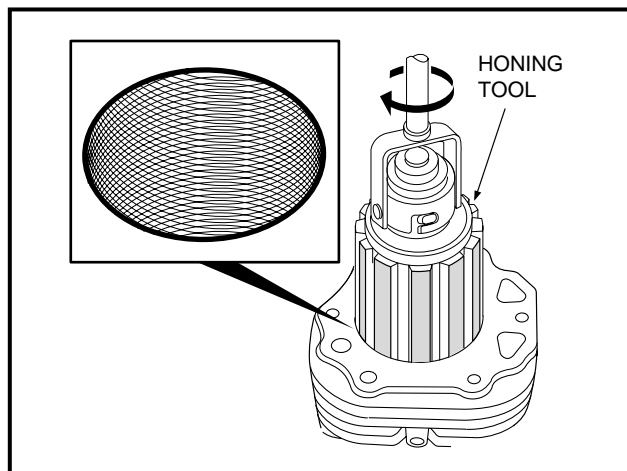

Figure 13-60 Hone Cylinder

To Resize Bore to Next Oversize

Always resize the bore to exactly 0.020 inches (0.50 mm) over standard size.

- The bore size 0.020 inches over standard size is 3.2858 - 3.2866 inches (83.460 - 83.480 mm). **See Specifications for Resizing Cylinder Bore on page 13-51.**

NOTE: Allow for shrinkage (from the final size) of 0.0003 - 0.0004 inches (0.0007 - 0.0009 mm) which will occur when the cylinder cools down.

2. Hone the cylinder to the final bore diameter of 3.2866 - 3.2874 inches (83.480 - 83.500 mm). **See Specifications for Resizing Cylinder Bore on page 13-51. See also following CAUTION and NOTE.**

NOTE: Important: The cylinder wall finish should have a 40° to 60° cross-hatch pattern (**Figure 13-60, Page 13-30**).

Do not use solvents or gasoline to clean cylinder after honing.

3. After honing, clean the cylinder wall thoroughly using soap, warm water and clean rags.
4. Dry the cylinder and coat with engine oil. **See following CAUTION.**

⚠ CAUTION

- The cylinder must be thoroughly cleaned after honing to eliminate all grit.

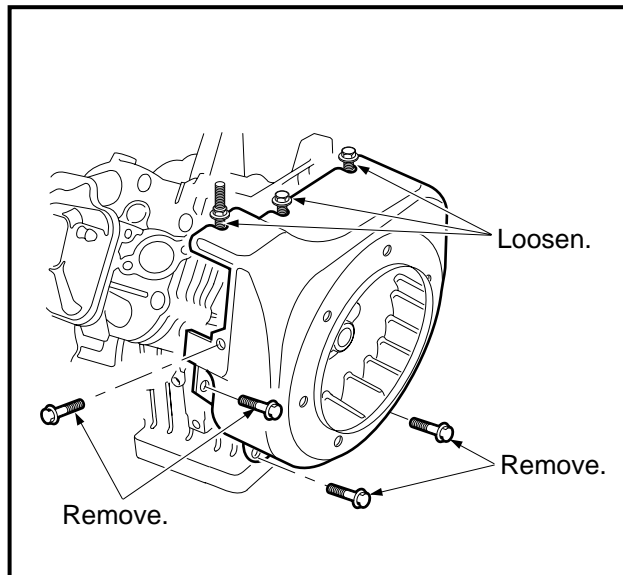

Figure 13-61 Flywheel Housing

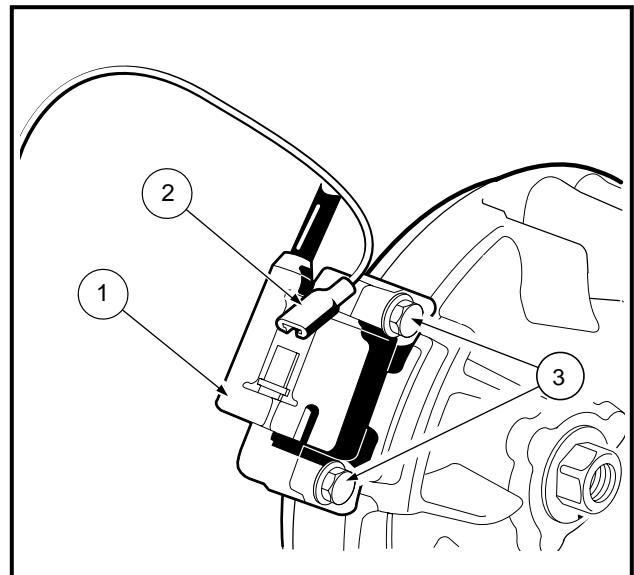

Figure 13-62 Ignition Coil

IGNITION COIL AND FLYWHEEL

Read **DANGER** and **WARNING** on page 13-1.

Ignition Coil and Flywheel Removal

1. Loosen three screws and remove the remaining four screws attaching the flywheel housing as shown, then remove the housing (**Figure 13-61, Page 13-31**).
2. Disconnect the ignition coil (1) from its primary lead wire at the connector (2). Remove the two bolts (3) and take out the ignition coil (**Figure 13-62, Page 13-31**).
3. Hold the flywheel (4), **not the fan** (7), with a strap wrench (5) and, using a 25 mm socket, remove the flywheel nut (and flat washer) by turning it counterclockwise (**Figure 13-63, Page 13-32**). **See following CAUTION.**

Ignition Coil and Flywheel Removal, Continued:**⚠ CAUTION**

- The flywheel nut has right-hand threads. Turn it clockwise to tighten, or counterclockwise to loosen.
 - Do not damage the fan blades with the strap wrench. Do not place screwdriver or pry bar in the fan blades.
4. Remove the flywheel with a puller.
 5. Remove the flywheel key from its groove.

Flywheel Installation

See Engine Assembly on page 13-48.

Ignition Coil Inspection and Repair

See Test Procedure 16, Section 11, Page 11-35.

Ignition Coil Installation

1. Installation is the reverse of removal.
2. While tightening the two bolts (3), use a bronze feeler gauge to adjust the ignition coil air gap to 0.012 in. (0.304 mm) (Figure 13-64, Page 13-32).
3. Tighten the two ignition coil bolts to 30 in-lb (3.4 N·m).

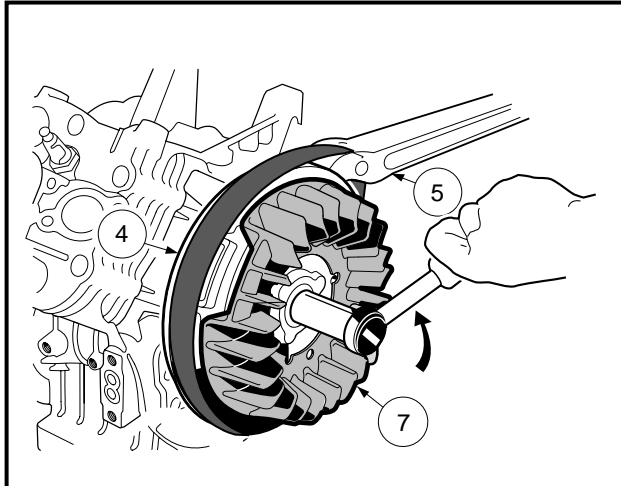

Figure 13-63 Flywheel Nut Removal

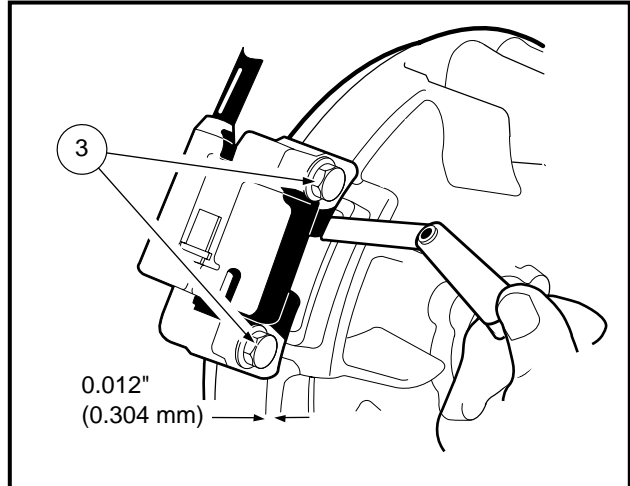

Figure 13-64 Adjust Ignition Coil Air Gap

OIL PUMP

Read **DANGER** and **WARNING** on page 13-1.

Oil Pump Cover Removal

1. Remove the six screws (1 - 6) and remove the oil pump cover (7) (Figure 13-65, Page 13-33).
2. Peel off the oil pump cover gasket (8).
3. Remove the pump gear cover plate (9) and filter screen (10).

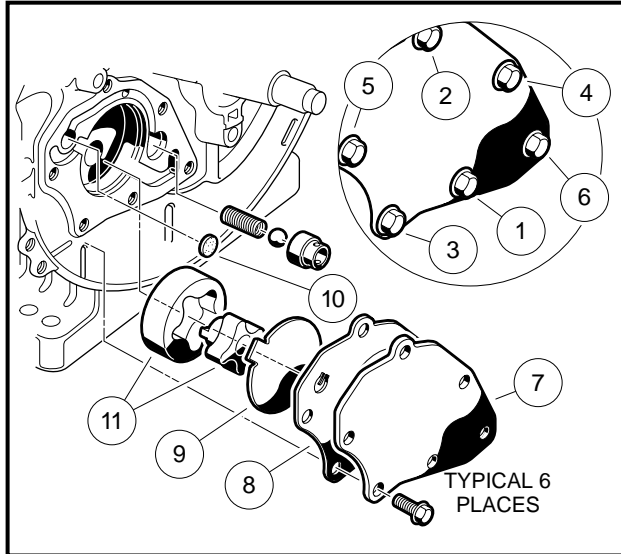

Figure 13-65 Oil Pump Removal

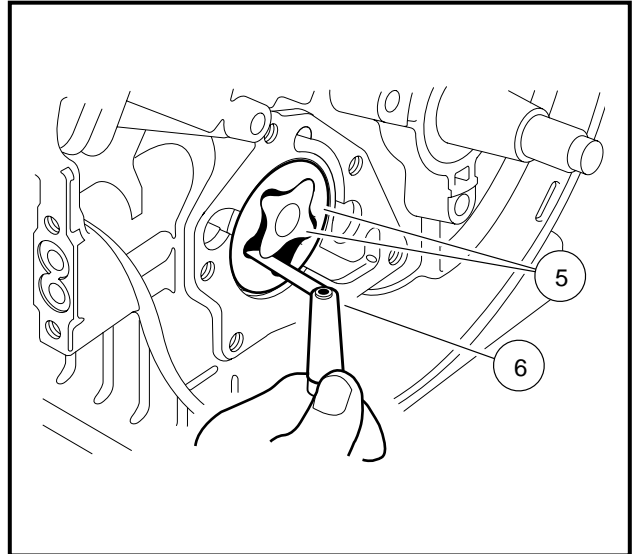

Figure 13-66 Measure Rotor Clearance

Oil Pump Inspection

1. Check the clearance between the inner and outer rotors (5) with a feeler gauge (6). Measure the clearance between the high point of the inner rotor and the high point of the outer rotor (**Figure 13-66, Page 13-33**).
2. Replace both rotors as a set if the measurement exceeds 0.012 inch (0.3 mm).
3. Remove inner and outer rotors (11) (**Figure 13-65, Page 13-33**).
4. Inspect the inner and outer oil pump rotors. If the rotors are worn or damaged, replace them.
 - 4.1. Measure the pump shaft bearing surface. Replace both rotors as a set if the measurement is less than 0.4971 inch (12.627 mm) (**Figure 13-67, Page 13-33**).
 - 4.2. Using a micrometer, measure the diameter of the outer rotor at several points (**Figure 13-68, Page 13-33**).
 - 4.3. If the rotor diameter is less than 1.5923 inches (40.467 mm), replace both rotors.
 - 4.4. Using a micrometer, measure the thickness of the outer rotor at several points (**Figure 13-69, Page 13-34**).
 - 4.5. If the rotor thickness is less than 0.3905 inch (9.920 mm), replace both rotors.

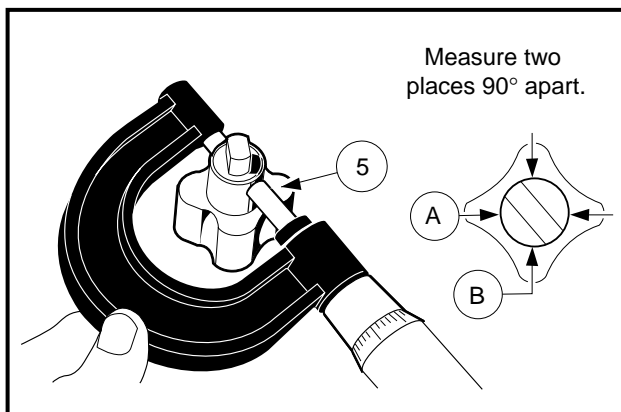

Figure 13-67 Measure Pump Shaft Bearing Surface

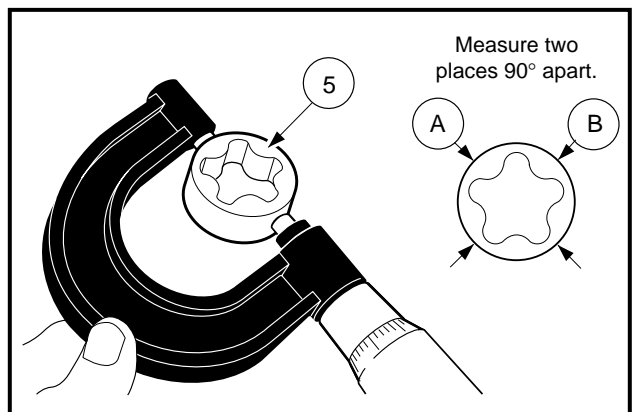

Figure 13-68 Measure Outer Rotor O.D.

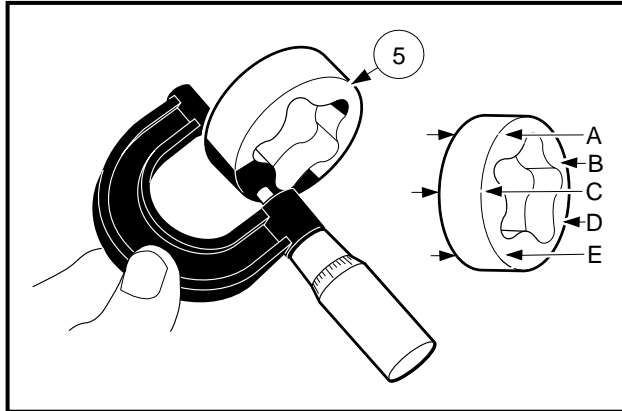

Figure 13-69 Measure Outer Rotor Thickness

OIL PRESSURE RELIEF VALVE

Oil Pressure Relief Valve Removal

1. Remove the oil pump cover. **See Oil Pump Cover Removal on page 13-32.**
2. Remove the valve seat (1), ball (2) and spring (3) (**Figure 13-70, Page 13-34**).

Oil Pressure Relief Valve Inspection

1. Note the condition of the ball (2) and the valve seat (1). They must not have any nicks or burrs. Replace if necessary (**Figure 13-70, Page 13-34**).
2. Inspect the relief valve spring (3) for pitting, cracks, rusting and burrs. Replace if necessary.
3. Measure free length of the spring (3) with a vernier caliper (**Figure 13-71, Page 13-34**). If the free length of the relief valve spring is less than 0.748 inches (19.00 mm), replace the spring.

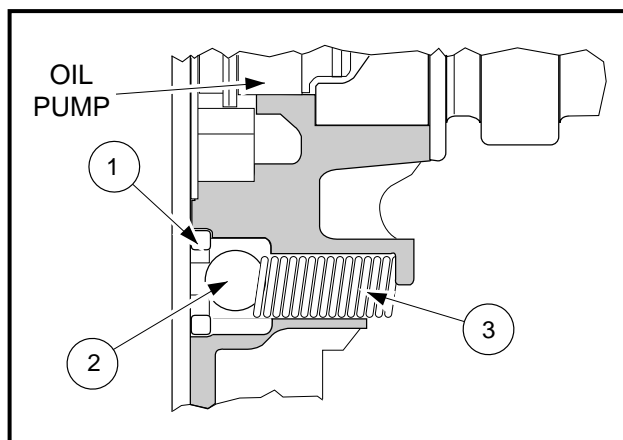

Figure 13-70 Oil Pressure Relief Valve

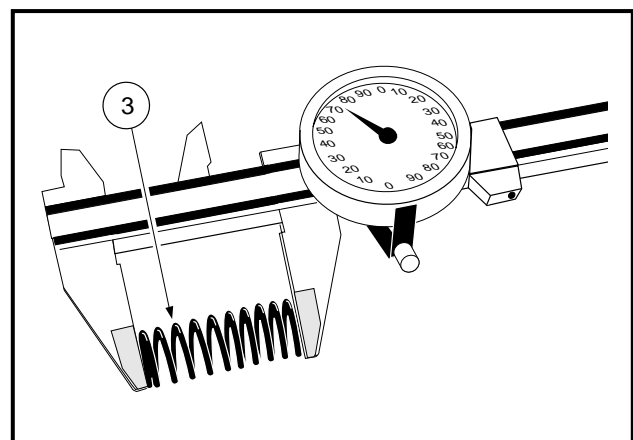

Figure 13-71 Measure Free Length of Spring

Oil Pressure Relief Valve Installation

1. Installation is the reverse of removal. If necessary, put the ball in position and lightly tap with a plastic hammer to form a perfect seat.

Oil Pump Installation

▲ CAUTION

- Do not allow any dust or other foreign matter into the oil pump.

1. Installation is the reverse of removal.
2. Install the inner rotor with its tang in the slot in the end of the camshaft (**Figure 13-72, Page 13-35**).
3. Install six bolts (1 - 6) and finger tighten. Then tighten to 7 ft-lb (9.5 N·m) in the sequence shown (**Figure 13-65, Page 13-33**). After tightening bolts, check the torque of the first bolt.

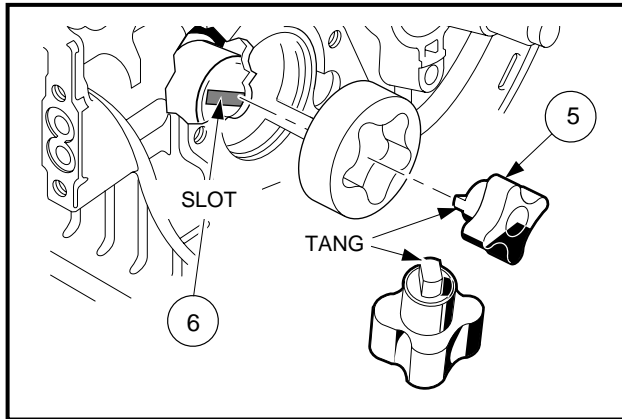

Figure 13-72 Install Inner Rotor

CRANKSHAFT AND COUNTERBALANCE

Read **DANGER** and **WARNING** on page 13-1.

Crankshaft and Counterbalance Removal

1. Remove the four nuts (1) and pull out the counterbalance guide shaft (2) and the O-ring (3) (**Figure 13-73, Page 13-35**).
2. Pull out the crankshaft and the counterbalance together as an assembly (**Figure 13-74, Page 13-35**).

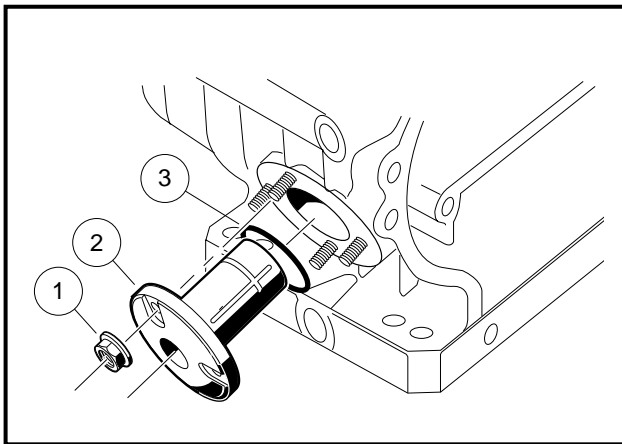

Figure 13-73 Counterbalance Guide Shaft and O-Ring Removal

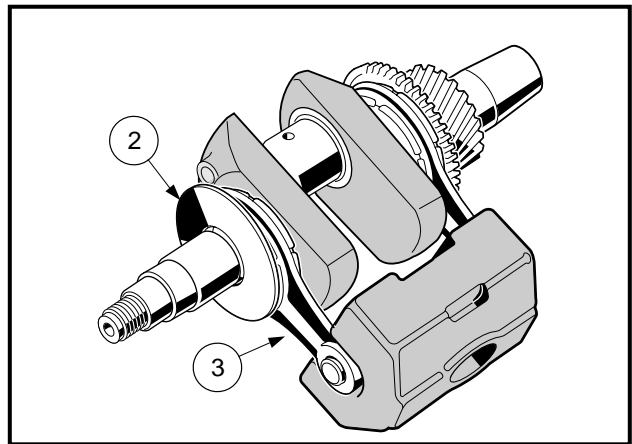

Figure 13-74 Crankshaft and Counterbalance

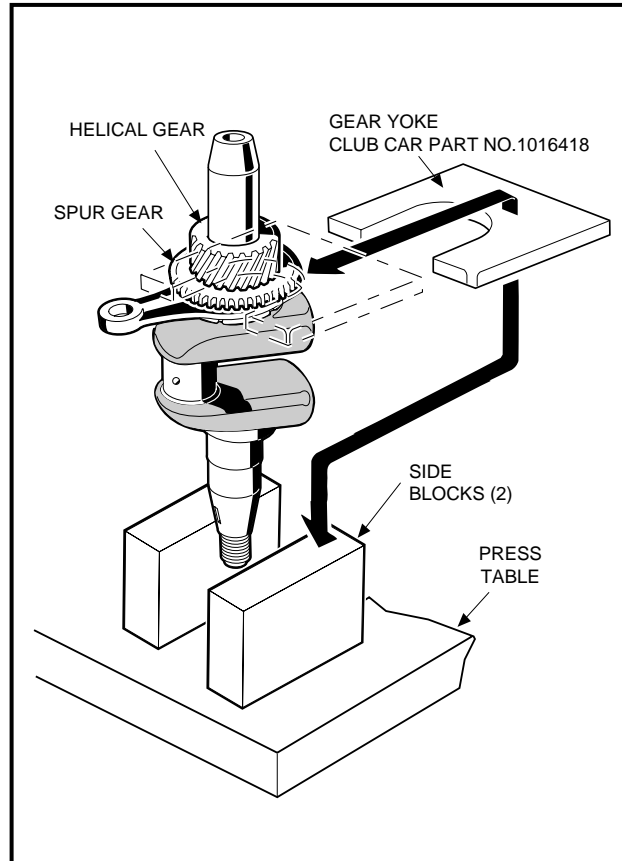

Figure 13-75 Place Assembly in Press

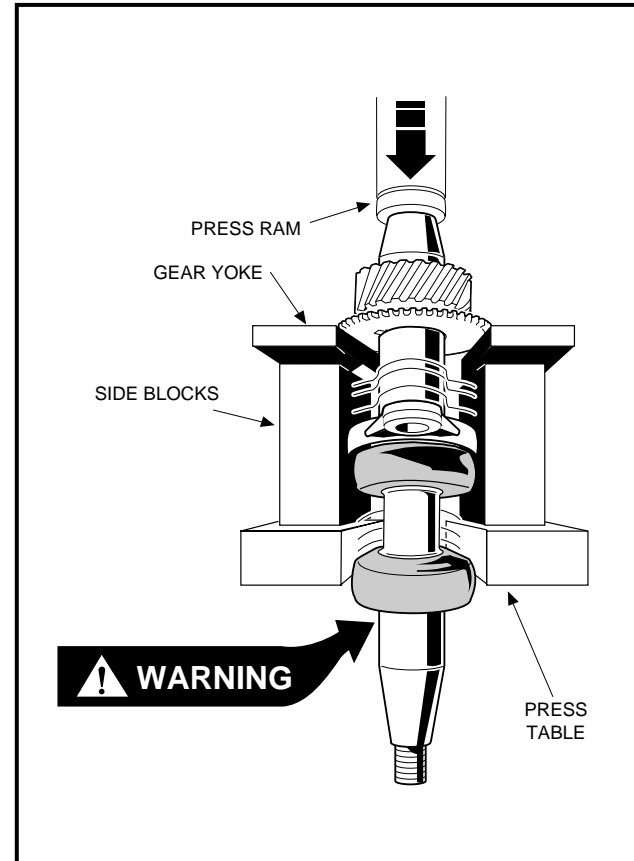

Figure 13-76 Remove Helical and Spur Gears

Crankshaft and Counterbalance Disassembly

1. Slide the spacer (2) and the link rod (3) off the flywheel end of the crankshaft. Remove the counterbalance from the remaining link rod (**Figure 13-74, Page 13-35**). **Go to Link Rod Inspection on page 13-37.**
2. If the link rods need replacing, place the gear yoke (CCI 1016418) under the spur gear with the small end of the connecting rod located opposite the crankpin (**Figure 13-75, Page 13-36**).
3. Position the gear yoke with the side blocks positioned as close to the crankshaft as possible (**Figure 13-75, Page 13-36**).
4. Using a press, push on the end of the crankshaft to pull the spur gear and the helical gear off the crankshaft (**Figure 13-76, Page 13-36**). **See following WARNING and CAUTION.**

⚠ WARNING

- Support the crankshaft while pressing. This will prevent the crankshaft from dropping to the floor after the gear has been removed.

⚠ CAUTION

- Use a press when removing the spur gear and helical gear from, or installing them on the crankshaft.

5. Remove the woodruff key.
6. Slide the remaining link rod off the crankshaft.

Link Rod Inspection

1. Clean and inspect the link rod (1) bearing surfaces. If the bearing surface of the small end is scored or damaged, replace the link rod. If the large end bearing is scored or damaged, the link rod must be replaced (**Figure 13-77, Page 13-37**).
 - 1.1. Using a telescoping gauge and micrometer, measure both inside bearing surfaces at several points.
 - 1.2. If the inside diameter of the small end is greater than 0.4746 inch (12.057 mm), replace the link rod (**Figure 13-78, Page 13-37**).
 - 1.3. If the inside diameter of the large end is greater than 1.9726 inches (50.106 mm), replace the link rod (**Figure 13-79, Page 13-37**). See following NOTE.

NOTE: Do not remove the link rod on the PTO (power take-off) side unless link rod on the opposite end needs replacement. The crank-gear is very tightly fitted to the crankshaft so that it can transfer engine torque to the camshaft (which also functions as a PTO shaft) (**Figure 13-77, Page 13-37**). Ignore Crankshaft and Counterbalance Disassembly (steps 2 through 6, page 13-36), if the link rod opposite of the PTO side passes inspection (**Figure 13-77, Page 13-37**).

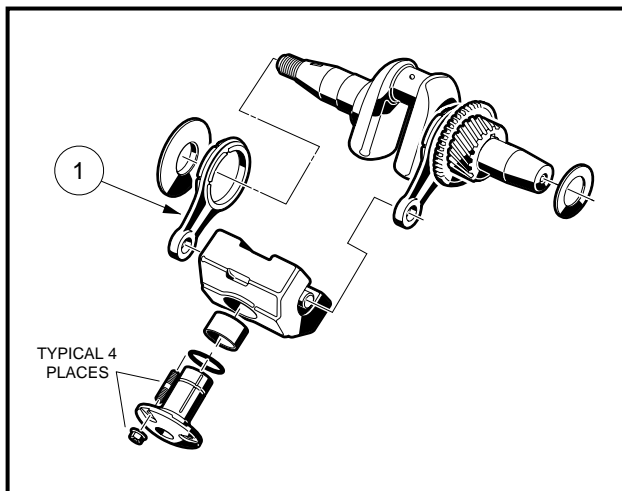

Figure 13-77 Inspect Link Rod

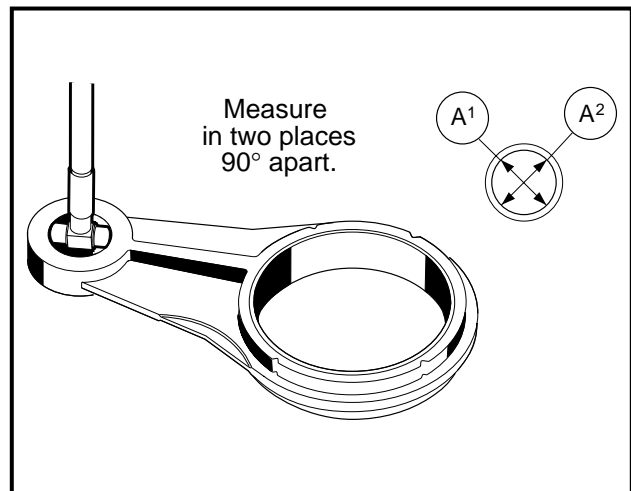

Figure 13-78 Measure Link Rod Small Bore I.D.

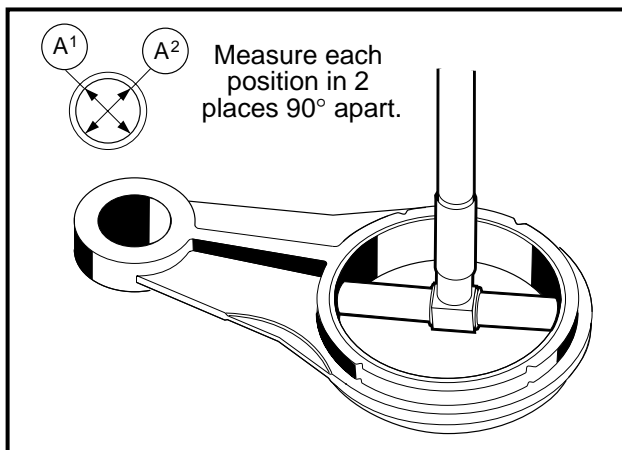

Figure 13-79 Measure Link Rod Large Bore I.D

COUNTERBALANCE WEIGHT

NOTE: The wrist pins are tightly pressed into the weight and normally require no maintenance.

Counterbalance Weight Inspection

1. Clean the inside bearing surface and inspect it for wear or damage.
2. Using a telescoping gauge and micrometer, measure the inside diameter of the bearing surface (**Figure 13-80, Page 13-38**).
3. If the inside diameter is greater than 1.0274 inches (26.097 mm), or the bearing shows signs of wear or damage, replace the counterbalance weight bearing.

Counterbalance Weight Bearing Replacement

1. Support the weight around the bearing hole and drive the bearing out of the counterbalance weight with a bearing driver. **See following NOTE.**

NOTE: Install the new bearing with its oil hole aligned with the oil passage in the counterbalance weight.

2. Clean the parts thoroughly in a high flash-point solvent and wipe dry.
3. Coat new bearing with clean engine oil.
4. Press the new bearing into the counterbalance weight.

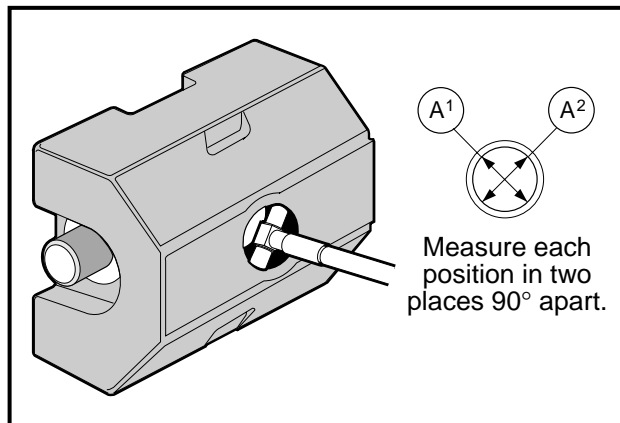

Figure 13-80 Measure Counterbalance Bearing Surface I.D.

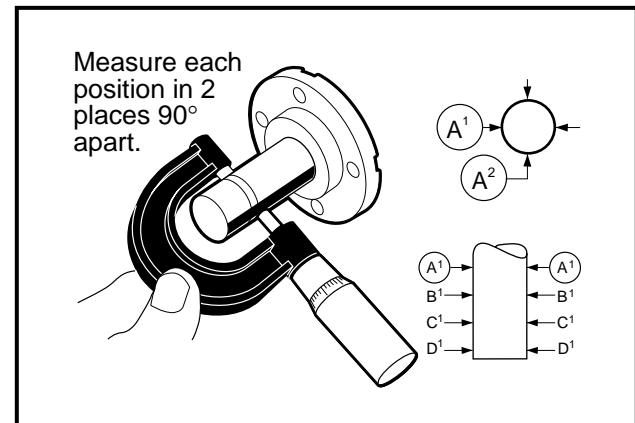

Figure 13-81 Measure O.D. of Counterbalance Guide Shaft

Counterbalance Guide Shaft Inspection

1. Clean the shaft surface and inspect it for wear or damage.
2. With an outside micrometer, measure the outside diameter of the guide shaft surface (**Figure 13-81, Page 13-38**).
3. If the outside diameter is smaller than 1.0199 inches (25.907 mm), or the shaft shows signs of wear or damage, replace the guide shaft.
4. Check the O-ring seal to make sure the O-ring is not damaged. Replace if necessary.

Crankshaft Inspection

NOTE: The crankshaft for a unitized (clockwise) engine has left-hand threads at the clutch mounting hole, and there is a machined groove in the outside diameter of the counterweight as shown below (**Figure 13-82, Page 13-39**).

1. Clean and inspect the journals for scoring. Inspect the crankshaft gear for cracks, scoring or broken teeth. Replace parts if necessary.
2. Using a micrometer, measure both main journals (PTO side and flywheel side) at several points along their lengths (**Figure 13-83, Page 13-39**).
3. If either journal diameter is less than 1.3751 inches (34.930 mm), replace the crankshaft.
4. Using a micrometer, measure the connecting rod journal at several points along its length (**Figure 13-84, Page 13-39**).
5. If the journal diameter is less than 1.4741 inches (37.444 mm), replace the crankshaft.
6. Using a micrometer, measure the crankshaft link rod journals at several points (**Figure 13-85, Page 13-39**).
7. If the diameter of either journal is less than 1.9655 inches (49.924 mm), replace the crankshaft.

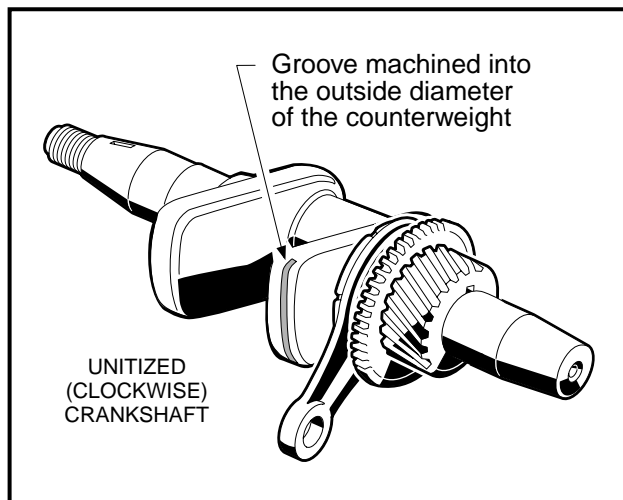

Figure 13-82 Crankshaft Inspection

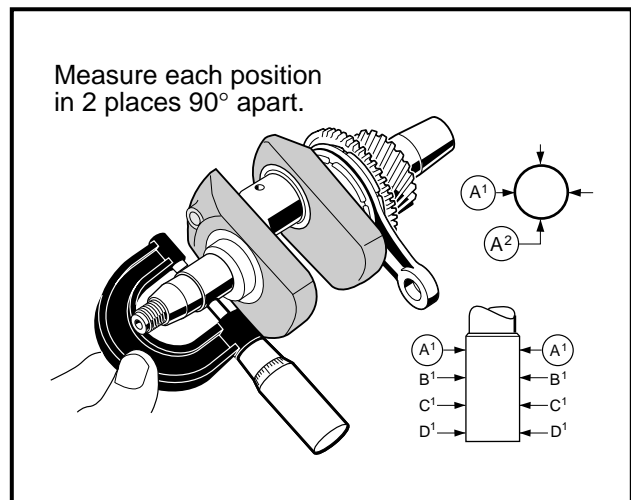

Figure 13-83 Measure Crankshaft Journals

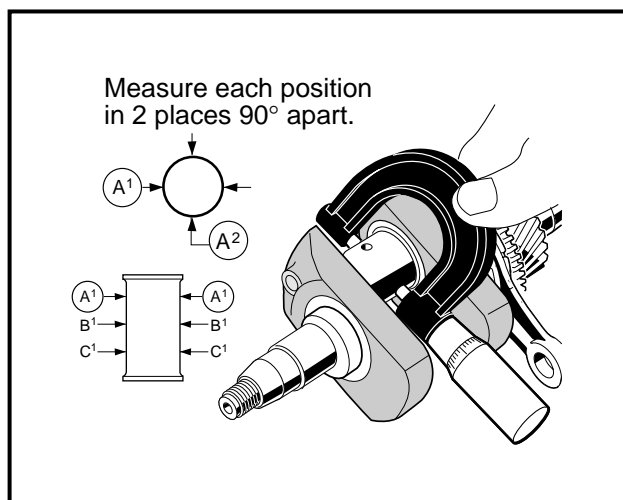

Figure 13-84 Measure Connecting Rod Journal

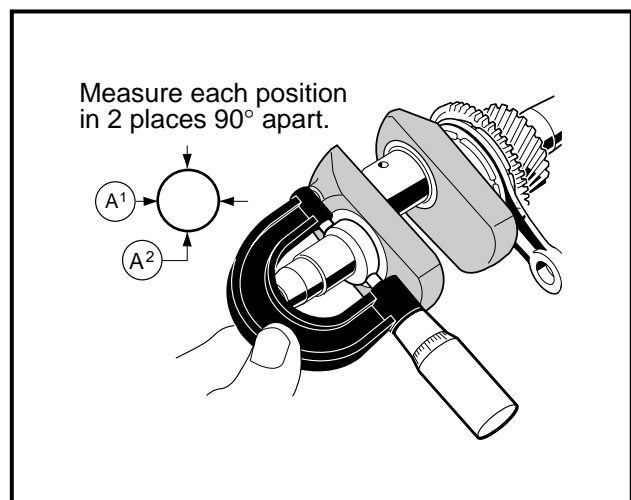

Figure 13-85 Measure Link Rod Journals

8. Check the crankshaft alignment.
 - 8.1. Place the crankshaft in an alignment jig.
 - 8.2. Turn crankshaft (1) slowly and measure total indicated run-out at the location shown (**Figure 13-86, Page 13-40**).
 - 8.3. If total run-out exceeds 0.002 inch (0.05 mm), replace the crankshaft.

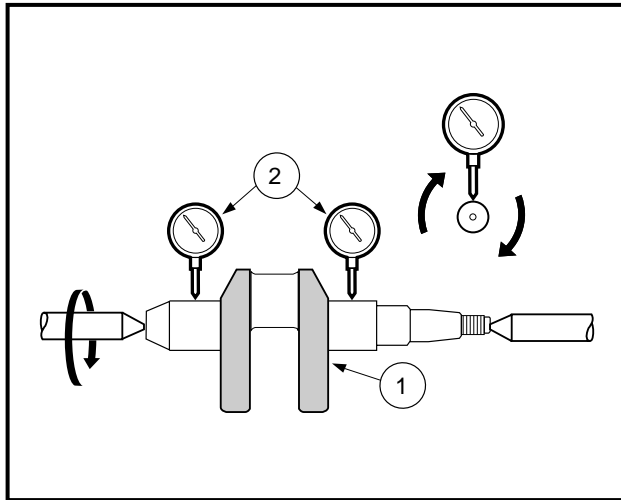

Figure 13-86 Check Crankshaft Alignment

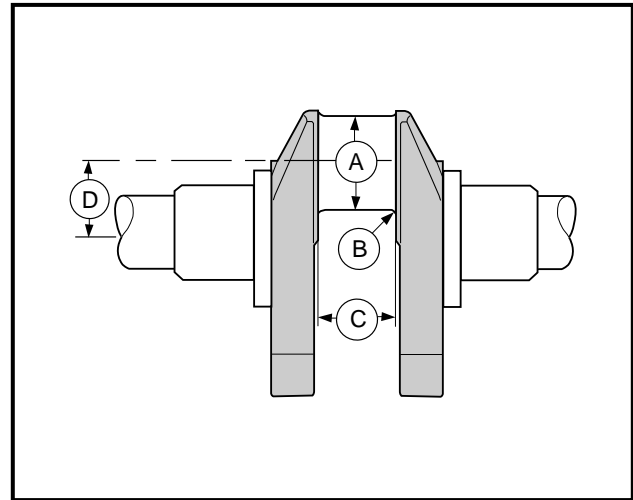

Figure 13-87 Undersized Connecting Rod Journal

Undersized Connecting Rod

The connecting rod journal can accept an undersized connecting rod with a 1.3779 inches (35.0 mm) inside diameter. Grinding the crankshaft is required before using the undersized connecting rod.

1. Have a reliable repair shop grind the crankshaft journal (A) (**Figure 13-87, Page 13-40**).
2. The final finishing dimensions are as follows (**Figure 13-87, Page 13-40**):
 - (A) 1.4759 - 1.4763 inches (37.489 - 37.500 mm)
 - (B) 0.110 - 0.126 inch (2.80 - 3.20 mm)
 - (C) 1.1968 inches maximum (30.4 mm)
 - (D) 1.2775 - 1.2814 inches (32.45 - 32.55 mm)
3. The connecting rod journal (A) must be concentric and cylindrical within 0.0002 inch (0.005 mm) at full indicator reading (**Figure 13-87, Page 13-40**).
4. Finish should be very smooth. Use a super fine finishing stone.

OIL SCREEN

Oil Screen Removal

1. Remove the two bolts (1) to take out the oil screen plate (2) and the oil screen (3) (**Figure 13-88, Page 13-41**).
2. Clean the oil screen thoroughly with a high flash-point solvent, then dry the screen.

Oil Screen Installation

1. To install the oil screen, reverse the removal procedure.
2. Tighten bolts (1) to 30 in-lb (3.4 N·m).

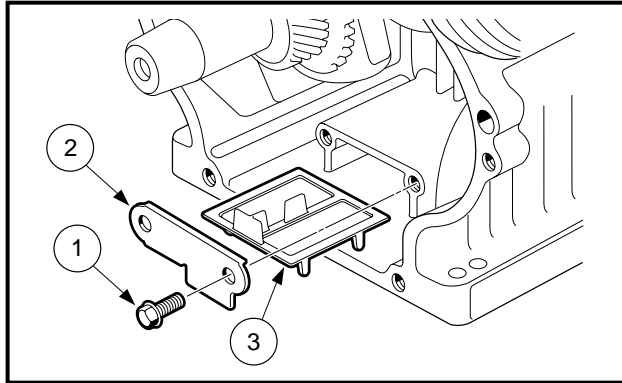

Figure 13-88 Oil Screen Removal

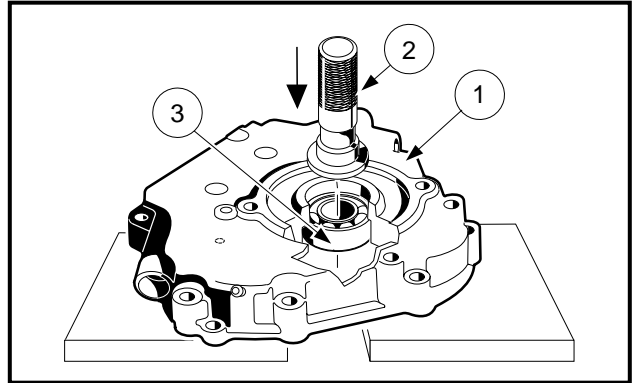

Figure 13-89 Ball Bearing Removal

BALL BEARING

Ball Bearing Removal

1. Remove the oil seal in the crankcase cover. **See following NOTE.**

NOTE: Never reuse an oil seal. Replace the oil seal with a new one.

2. Place the crankcase cover (1) on a bench with its outside up (gasket surface against bench) (**Figure 13-89, Page 13-41**).
3. Using a bearing driver (2) (Part of Club Car Bearing Driver Kit, Part No. 1016416), drive out the ball bearing (3) as shown.

Ball Bearing Inspection

1. Clean the ball bearing thoroughly in high flash-point solvent and dry it.

NOTE: Never use compressed air to dry bearing. Use of compressed air will result in premature bearing failure.

2. Spin the ball bearing by hand and check for (A) axial play and (B) radial play. Replace the ball bearing if it is noisy, does not spin smoothly, or if it has any play (**Figure 13-90, Page 13-41**).

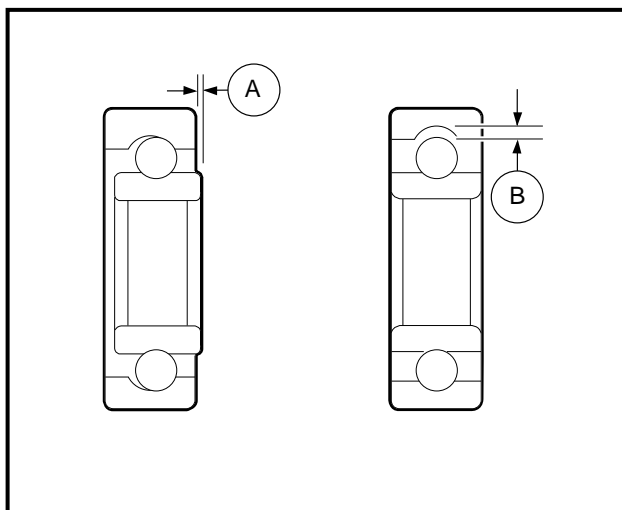

Figure 13-90 Check Ball Bearing

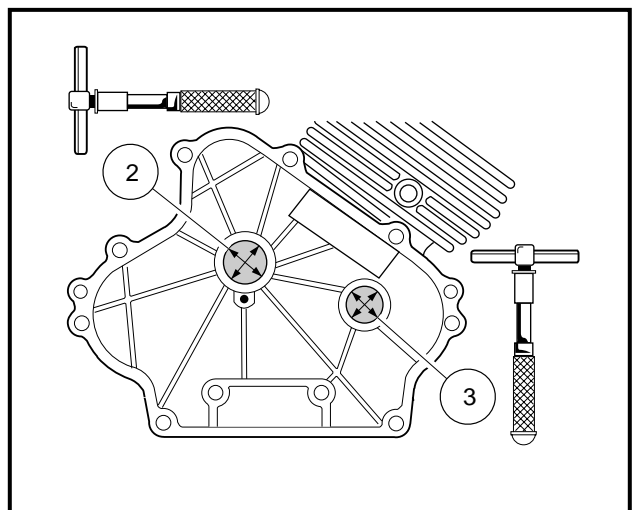

Figure 13-91 Inspect Bearing Surfaces in Crankcase

OIL SEALS

Oil seals are used on both ends of the crankshaft. Any time the crankshaft is removed from the seals, the seals must be replaced with new ones.

Oil Seal Removal

Use an oil seal remover to press or drive the seal out of the casing.

Oil Seal Installation

NOTE: Never reuse an oil seal. Replace the oil seal with a new one.

1. Put a light coating of clean engine oil on the outside edge and the inner lip of the oil seal to assist installation.
2. Install all oil seals with their lips facing the center of the engine.
3. Using the 1.37 inch (35 mm) seal driver, press the oil seal into the flywheel side of the crankcase until it is flush with the hole.
4. Using the 1.97 inch (50 mm) seal driver, press the oil seal into the crankcase cover until it is 0.157 inch (4 mm) below the outside surface.

Plain Bearing Surface Inspection

Plain bearing surfaces are used for both ends of the camshaft and the flywheel end of the crankshaft.

1. Inspect the camshaft surfaces, one in the crankcase (3) (**Figure 13-91, Page 13-41**) and the other in the crankcase cover (1) (**Figure 13-92, Page 13-42**). Using an inside micrometer or telescoping gauge, measure the inside diameter of each bearing surface. If the inside diameter is greater than 0.9080 inch (23.063 mm), replace the crankcase and/or the crankcase cover.
2. Inspect the crankshaft bearing surface (2) in the crankcase. Using an inside micrometer or telescoping gauge, measure the inside diameter of the bearing surface. If the inside diameter is greater than 1.1841 inch (30.075 mm), replace the crankcase (**Figure 13-91, Page 13-41**).

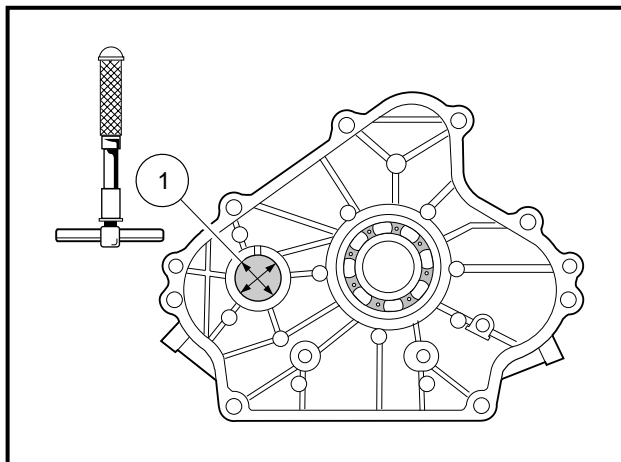

Figure 13-92 Inspect Camshaft Bearing Surface in Crankcase Cover

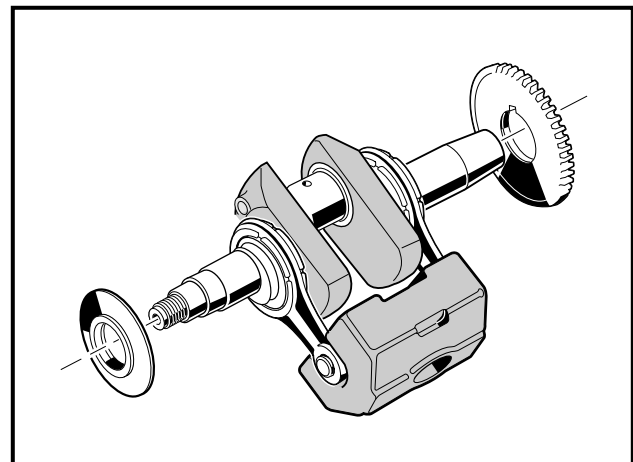

Figure 13-93 Crankshaft Assembly

Crankshaft Installation

⚠ WARNING

- Before assembly, make sure all parts are clean.

NOTE: When reassembling the crankshaft and the counterbalance weight, apply a light film of engine oil to the crankshaft journals and guide shaft (**Figure 13-93, Page 13-42**).

1. Installation is the reverse of removal. See **Crankshaft and Counterbalance Removal on page 13-35**.
2. Tighten the four nuts (2) for counterbalance guide shaft to 50 in-lb (5.9 N·m) (**Figure 13-73, Page 13-35**).
3. If the link rod was removed from the PTO side of the crankshaft, support the crankweb as shown, slide the link rod onto the crankshaft, and install the key. Press the spur gear and helical gear onto the crankshaft (**Figure 13-94, Page 13-43 and Figure 13-95, Page 13-43**). See following **CAUTION** and **NOTE**.

⚠ CAUTION

- Use a press when removing or installing the spur gear and helical gear on the crankshaft.
- If the spur gear was warped while being removed, install a new one.

NOTE: Make sure the chamfered inside diameters of the spur gear and helical gear are oriented downward on the crankshaft as shown (**Figure 13-94, Page 13-43**).

Make sure the link rods rotate smoothly after the gears are pressed on.

4. Slide the link rod, then the spacer, onto the flywheel end of the crankshaft.

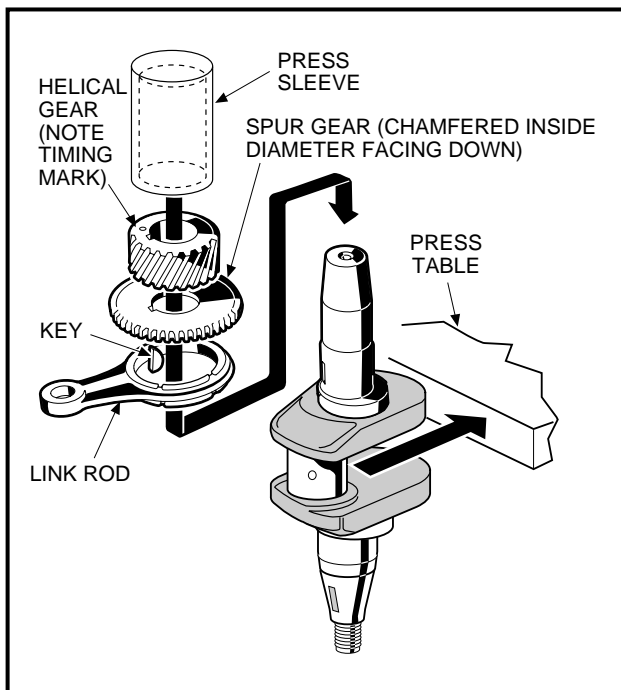

Figure 13-94 Crankshaft Installation

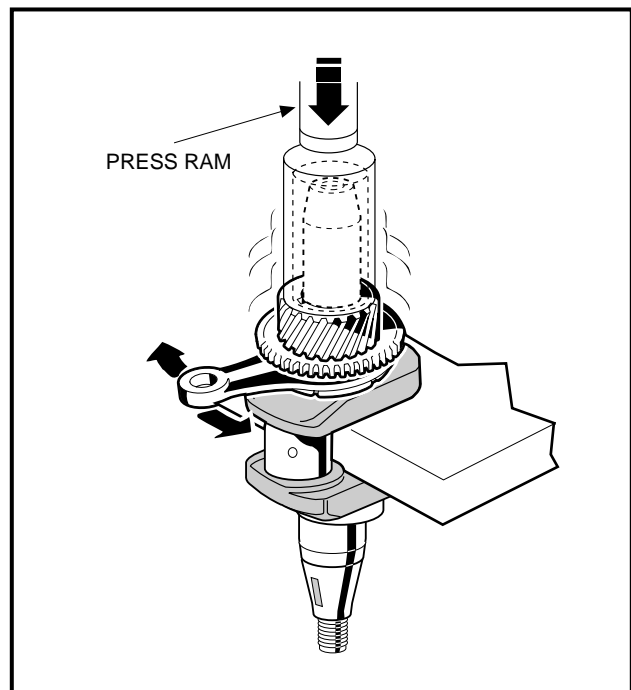

Figure 13-95 Press on Spur Gear and Helical Gear

Piston and Connecting Rod Installation

1. Installation is the reverse of removal.
2. Reassemble the piston and the connecting rod into a unit, if disassembled. Align the L mark (1) on the piston head toward the lettering MADE IN JAPAN (2) on the connecting rod (**Figure 13-96, Page 13-44**).
3. Apply a light film of engine oil to the connecting rod bearing surfaces, and the two connecting rod bolts.
4. Put the piston/connecting rod into the cylinder bore with the lettering MADE IN JAPAN on the connecting rod oriented toward the flywheel side of the engine. Position piston ring gaps so that they are oriented toward the corresponding letters in (**Figure 13-97, Page 13-44**): (A) Top Ring Gap, (B) Second Ring Gap, (C) Upper Side Rail Gap, (D) Lower Side Rail Gap.

NOTE: The R mark on the top two piston rings should be facing up when installed.

5. Tighten the two connecting rod bolts to 16.5 ft-lb (23 N·m).

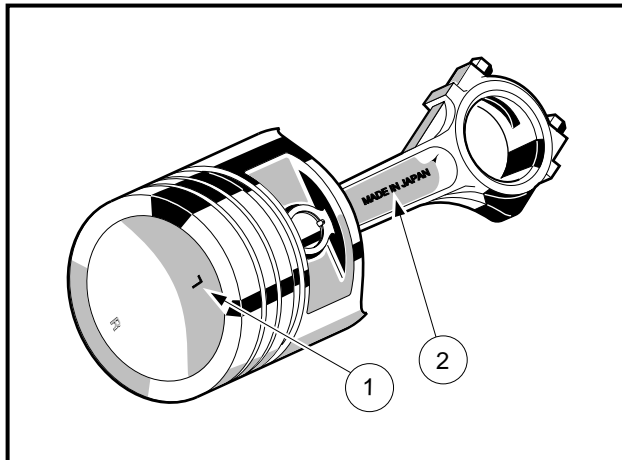

Figure 13-96 Piston Head and Connecting Rod Alignment

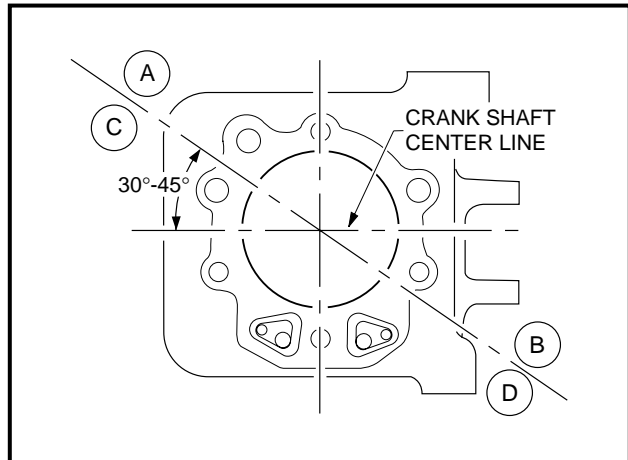

Figure 13-97 Piston Ring Gap Alignment

CRANKSHAFT AXIAL PLAY ADJUSTMENT

Read **DANGER** and **WARNING** on page 13-1.

1. With the gasket installed on the crankcase, measure from the gasket surface (1) to the helical gear surface (2). Record measurement (A) (**Figure 13-98, Page 13-45**).
2. Measure from the crankcase cover (3) mounting face to the crankshaft bearing inner end (4). Record measurement (B) (**Figure 13-98, Page 13-45**).
3. Locate the measurements on the Crankshaft Shim Table. Follow lines to where the recorded measurements intersect (**Figure 13-100, Page 13-45**).
4. Choose the next smaller shim from the table. Example: Measurement A is 15.87 mm and B is 17.66 mm. The correct crankshaft shim is 1.53 mm (**Figure 13-100, Page 13-45**). **See following NOTE.**
5. Install the shim (5) on the crankshaft (6) (**Figure 13-99, Page 13-45**).

NOTE: Crankshaft shim sizes for FE350 engines range from 1.11 to 1.81 mm.

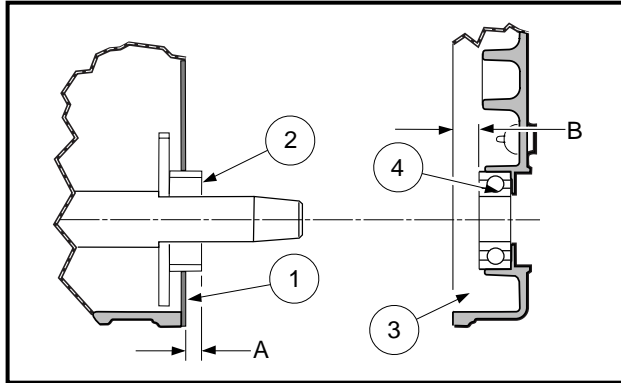

Figure 13-98 Determine Crankshaft Shim Size

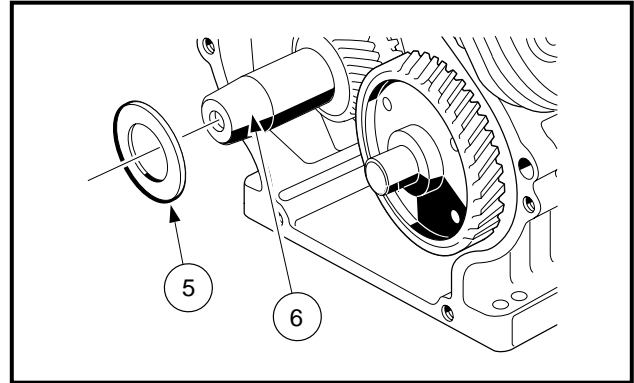
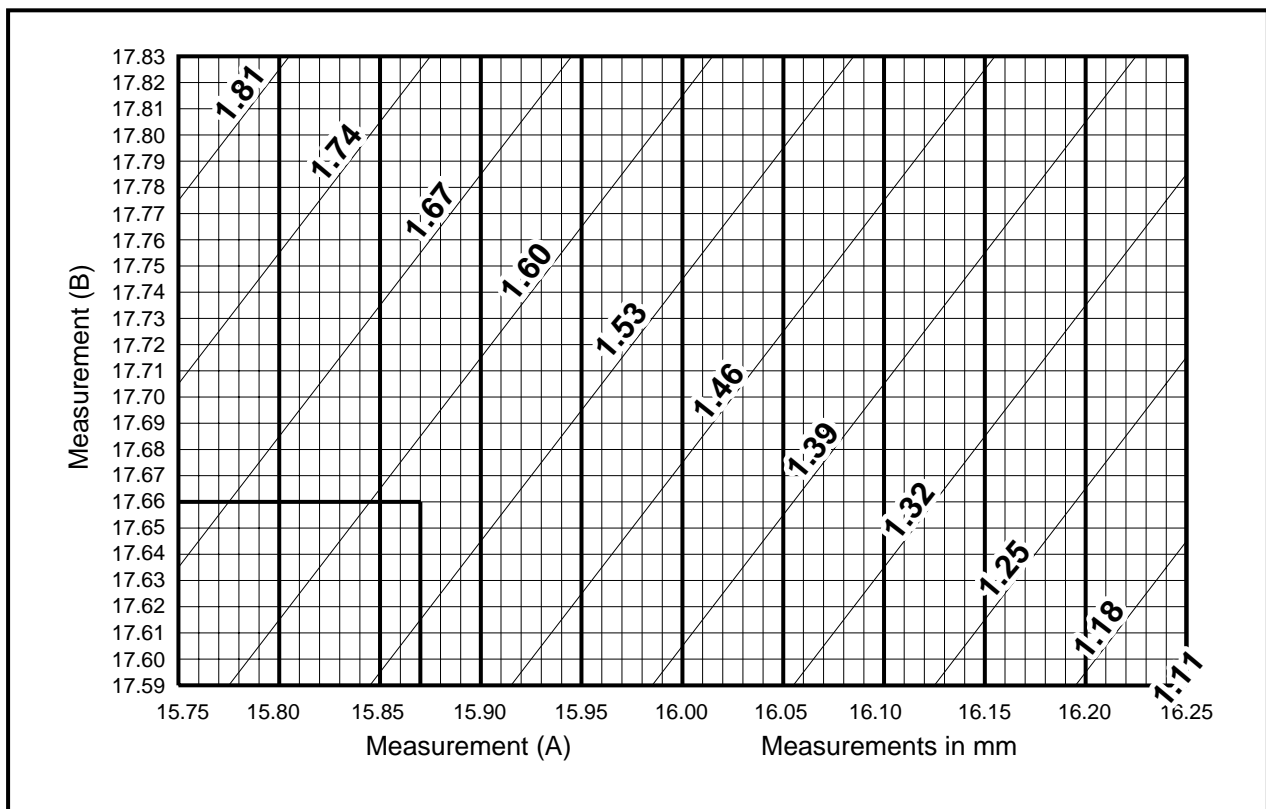

Figure 13-99 Install Shim On Crankshaft



Camshaft Installation, Continued:

- Align the timing marks (3) (Figure 13-102, Page 13-46). See following NOTE.

NOTE: If the outside edges of the camshaft and crankshaft gears are not flush, and the crankcase cover will not easily make full contact with the crankcase, make sure the tang on the oil pump rotor is seated in the camshaft slot.

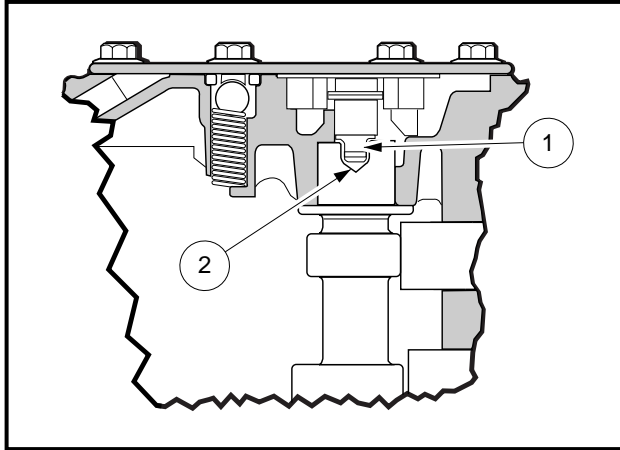

Figure 13-101 Proper Seating of Tang into Camshaft Slot

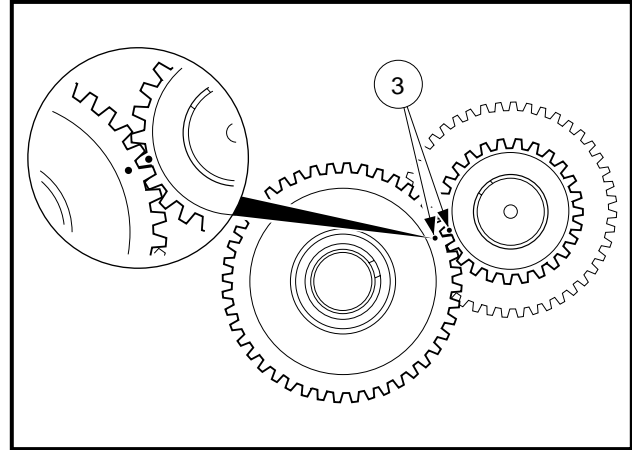

Figure 13-102 Align Timing Marks between Camshaft and Crankshaft

Camshaft Axial Play Adjustment

- With the gasket (1) installed on the crankcase, measure from the gasket surface to the cam gear surface (2). Record this measurement (Figure 13-103, Page 13-46).
- Measure from the crankcase cover (3) mounting face to the camshaft bearing inner end (4).
- Locate the measurements on the Camshaft Shim Table. Follow the lines to where the recorded measurements intersect (Figure 13-105, Page 13-47).
- Choose the next smaller shim from the table. EXAMPLE: Measurement A is 13.41 mm and B is 14.09 mm. The correct camshaft shim is 0.4 mm.
- Install the shim (1) on the camshaft (2) (Figure 13-104, Page 13-46).

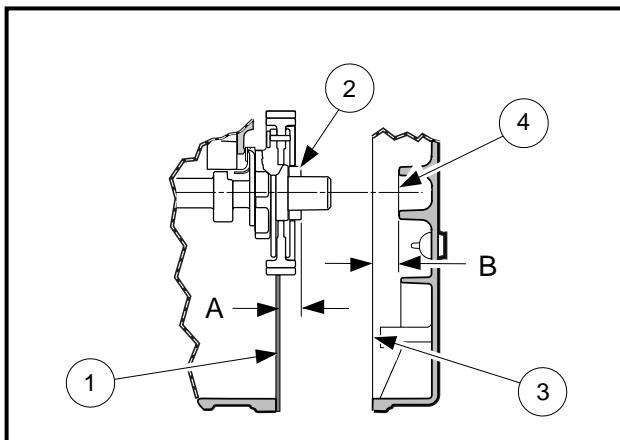

Figure 13-103 Measurements to be Recorded for Camshaft Shim Table

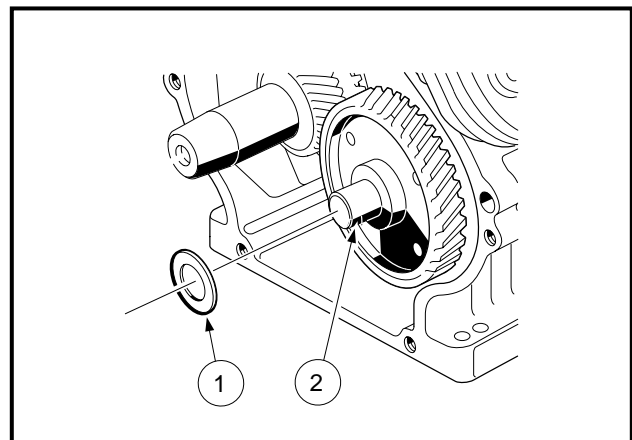

Figure 13-104 Shim Installation on Camshaft

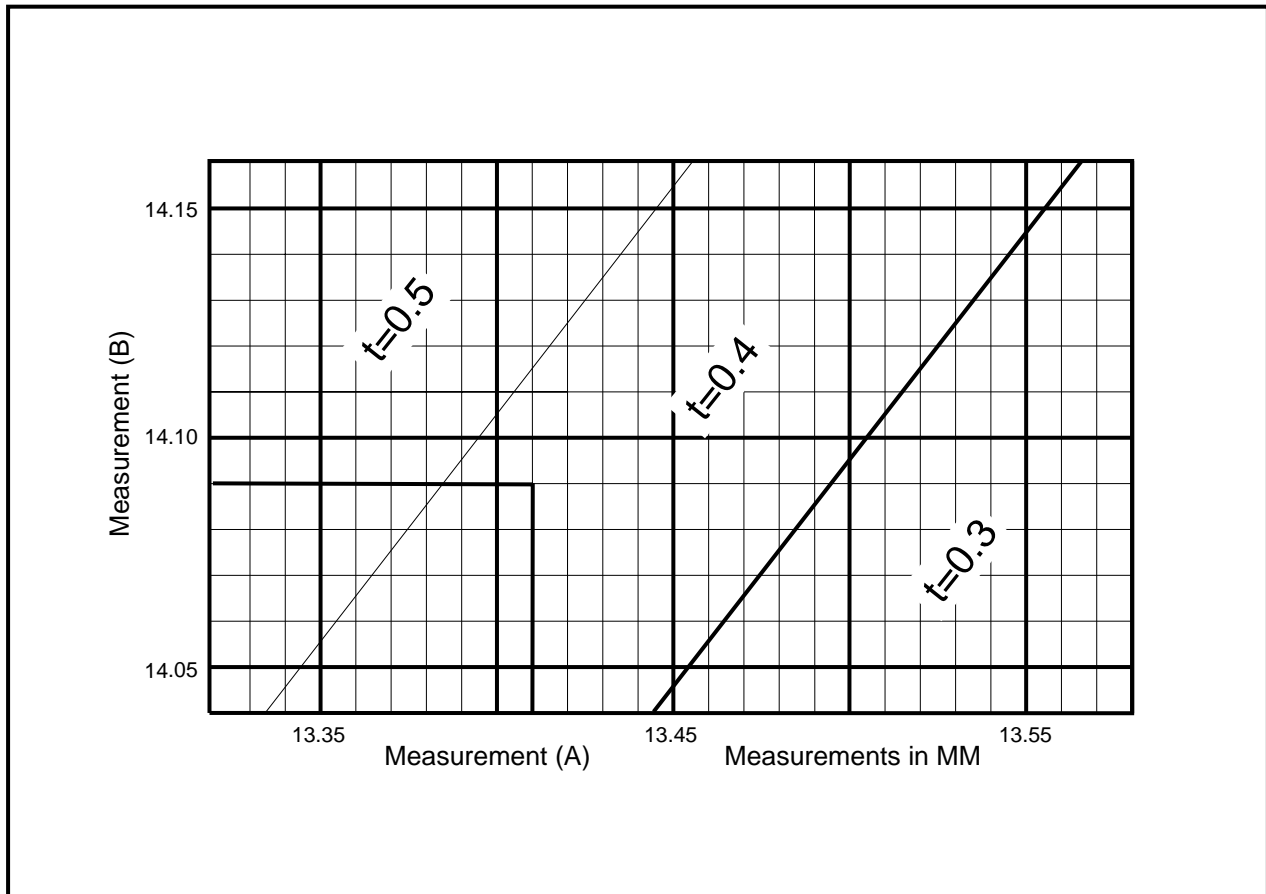

Figure 13-105 Camshaft Shim Table

CRANKCASE COVER INSTALLATION

▲ CAUTION

- Before assembly, make sure parts are clean.
- Do not reuse the gasket. Install a new one.
- Install and tighten crankcase cover bolts as instructed. Failure to do so could cause the cover to become warped.

1. Clean the gasket surfaces on the crankcase cover to fit a new gasket during installation and inspect the oil seal for wear and damage.
2. Install crankcase cover. Using HANDS ONLY, seat cover completely against the crankcase. If the cover will not seat, the camshaft is not installed correctly.
3. Install and finger tighten evenly the eight cover mounting bolts (**Figure 13-106, Page 13-48**).
4. Tighten the cover mounting bolts in two steps. First, in the sequence shown, tighten all eight bolts to approximately 130 in-lb (14 N·m). Then, repeating the sequence, tighten them to 250 in-lb (28.2 N·m).
5. Connect the yellow jumper wire (11) to the cord connector (12) (**Figure 13-42, Page 13-22**).

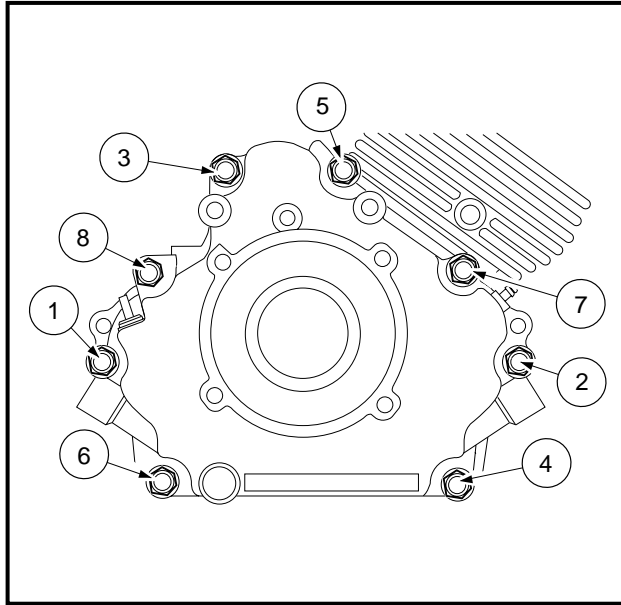

Figure 13-106 Crankcase Cover Installation

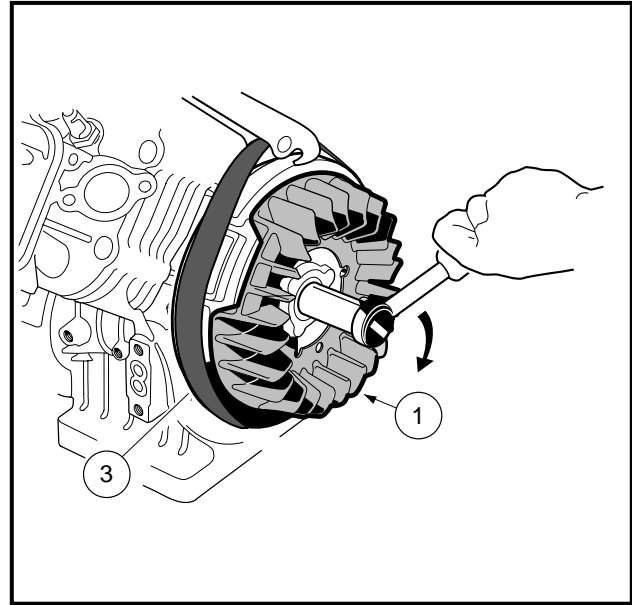

Figure 13-107 Fan and Flywheel Assembly

ENGINE ASSEMBLY

Read **DANGER** and **WARNING** on page 13-1.

⚠ CAUTION

- Before assembly, make sure parts are clean.

1. Install cylinder head. **See Cylinder Head Installation on page 13-19.**
2. Insert the flywheel key into the keyway in the crankshaft. Then align the keyway in the flywheel to the key and push the flywheel and fan assembly onto the crankshaft until it seats. Install flat washer and nut finger-tight.
3. Use a strap wrench (3) to keep the flywheel and fan assembly (1) from turning while tightening the flywheel nut to 63 ft-lb (85.4 N·m) (**Figure 13-107, Page 13-48**). **See following CAUTION.**

⚠ CAUTION

- The flywheel nut has right-hand threads. Turn it clockwise to tighten, or counterclockwise to loosen.
 - Be careful not to damage the fan blades. Use a strap wrench to hold flywheel. Do not place screwdriver or pry bar between fan blades.
4. Install ignition coil. **See Ignition Coil Installation on page 13-32.**
 5. Install cylinder head shrouds. Installation is the reverse of removal. **See Cylinder Shroud Removal, Steps 11 and 12, Page 13-9.**

6. Install carburetor. **See Section 14 – Fuel System.**
7. Place engine onto engine mounting plate and tighten the mounting hardware (1, 2 and 5) to 21 ft-lb (28.4 N-m). Tighten nuts (6) to 17 ft-lb (23.1 N-m) (**Figure 13-44, Page 13-23**).
8. Install drive clutch. **See Section 17 – Torque Converter.**
9. Install drive belt. **See Section 17 – Torque Converter.**
10. Install muffler. **See Section 15 – Exhaust System.**
11. Install starter/generator and belt. **See Section 12 – Electrical Components.**
12. Install the powertrain by performing steps 14 through 36, pages 16-40 through 16-46 in Section 16 – Unitized Transaxle with Differential Lock.
13. Install oil drain plug in the crankcase and tighten to 20 ft-lb (27.1 N-m). Apply a light film of oil on the seal of a new oil filter and install the filter on the crankcase. Fill the crankcase to the proper level with the correct type of oil. This engine should be regarded as a new engine for next scheduled oil change. **See Section 10 – Periodic Maintenance.**
14. Check all hardware for proper torque/tightness.
15. Check engine oil level (**Figure 13-108, Page 13-49**).
 - 15.1. Vehicle should be on a level surface when checking oil. Do not overfill with oil.

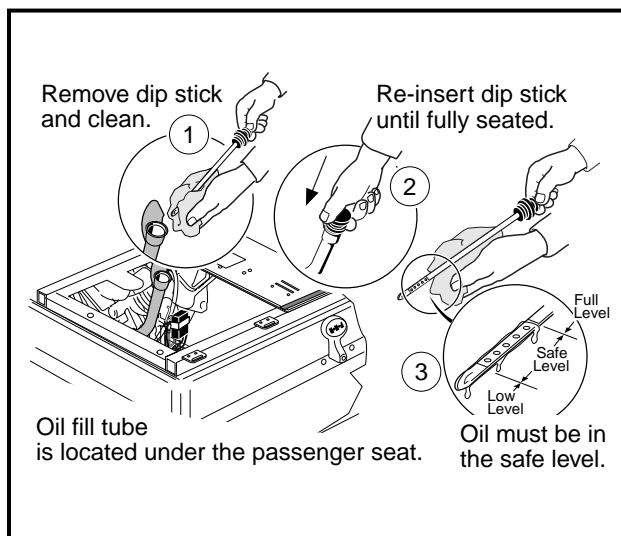

Figure 13-108 Check Engine Oil Level

16. Install a new or cleaned spark plug, gapped to 0.027 to 0.031 in. (0.69 to 0.79 mm), and connect plug wire to plug.
17. Connect the battery cables, positive first and tighten to 20 ft-lb (27.1 N-m).
18. Adjust the engine RPM setting. **See Engine RPM Adjustment, Section 14, Page 14-13.**
19. Test-drive vehicle to ensure all systems are functional and correctly adjusted.

SERVICE SPECIFICATIONS

ITEM	SPEC.	SERVICE LIMIT
Crankshaft axial play		0.0137 in. (0.35 mm)
Crankshaft crankpin journal	O.D. min.	1.4741 in. (37.444 mm)
Crankshaft PTO-side journal	O.D. min.	1.3751 in. (34.930 mm)
Crankshaft flywheel-side journal	O.D. min.	1.3751 in. (34.930 mm)
Crankshaft balancer- link-rod journals	O.D. min.	1.9655 in. (49.924 mm)
Camshaft axial play		0.0137 in. (0.35 mm)
Camshaft PTO-side journal	O.D. min.	0.9026 in. (22.927 mm)
Camshaft flywheel-side journal	O.D. min.	0.9026 in. (22.927 mm)
Camshaft cam lobes (intake and exhaust)	O.D. min.	1.3086 in. (33.24 mm)
Connecting rod big-end bearing	I.D. max.	1.4790 in. (37.567 mm)
Connecting rod small-end bearing	I.D. max.	0.7894 in. (20.051 mm)
Counterbalancer link rod big-end bearing	I.D. max.	1.9726 in. (50.106 mm)
Counterbalancer link rod small-end bearing	I.D. max.	0.4746 in. (12.057 mm)
Piston top ring groove clearance (with new ring)	max.	0.0063 in. (0.16 mm)
Piston second ring groove clearance (with new ring)	max.	0.0055 in. (0.14 mm)
Piston oil-ring groove clearance and end gap		Visual inspection only
Piston pin	O.D. min.	0.7864 in. (19.975 mm)
Piston pin hole	I.D. max.	0.7887 in. (20.033 mm)
Crankcase cover camshaft bearing	I.D. max.	0.9079 in. (23.063 mm)
Cylinder bore	I.D. Standard	3.2669 to 3.2677 in. (82.980 to 83.000 mm)
Cylinder bore	I.D. max.	3.2703 in. (83.067 mm)
Cylinder bore (out of round)	max.	0.0022 in. (0.056 mm)
Crankshaft bearing	I.D. max.	1.3809 in. (35.075 mm)
Camshaft bearing	I.D. max.	0.9080 in. (23.063 mm)
Oil pump housing	I.D. max.	1.6050 in. (40.766 mm)
Oil pump housing	Depth max.	0.4004 in. (10.170 mm)
Oil pump shaft bearing	I.D. max.	0.5028 in. (12.770 mm)
Rocker shaft	O.D. min.	0.4704 in. (11.949 mm)
Rocker arm bearing	I.D. max.	0.4754 in. (12.074 mm)
Valve seat angle (exhaust, intake)	Standard	45° (Ex.), 30° (In.)
Valve seat width	Standard	0.0197 to 0.0433 in. (0.50 to 1.10mm)
Valve seat width	max.	0.075 in. (1.9 mm)
Valve face angle (exhaust, intake)	Standard	45° (Ex.), 30° (In.)

ITEM	SPEC.	SERVICE LIMIT
Valve margin (exhaust, intake)	max.	0.024 in. (0.6 mm)
Intake valve stem	O.D. min.	0.2728 in. (6.930 mm)
Exhaust valve stem	O.D. min.	0.2722 in. (6.915 mm)
Valve guide hole (intake)	I.D. max.	0.2781 in. (7.065 mm)
Valve guide hole (exhaust)	I.D. max.	0.2781 in. (7.065 mm)
Valve spring (free length)	min.	1.5157 in. (38.50 mm)
Oil pump shaft	O.D. min.	0.4971 in. (12.627 mm)
Outer rotor	O.D. min.	1.5932 in. (40.467 mm)
Outer rotor width	min.	0.3905 in. (9.92 mm)
Relief valve spring (free length)	min.	0.748 in. (19.0 mm)
Counterbalance weight bearing	I.D. max.	1.0274 in. (26.097 mm)
Counterbalance guide shaft	O.D. min.	1.0199 in. (25.907 mm)
Breather reed valve (valve tip air gap)	max.	0.008 in. (0.2 mm)
Valve stem (exhaust, intake) (stem bend)	max.	0.0012 in. (0.03 mm)
Push rod (rod bend)	max.	0.0196 in. (0.50mm)
Valve guide (exhaust, intake)	I.D. Standard	0.2756 to 0.2762 in. (7.00 to 7.015 mm)

SPECIFICATIONS FOR RESIZING CYLINDER BORE

ITEM	OVER SIZE	LIMITS
Final boring bore diameter	0.020 in. (0.50 mm)	3.2858 to 3.2866 in. (83.460 to 83.480 mm)
Finished honed bore diameter	0.020 in. (0.50 mm)	3.2866 to 3.2874 in. (83.480 to 83.500 mm)

TORQUE SPECIFICATIONS

ITEM	SIZE	LIMITS
Cylinder head bolts	M8	17.5 ft-lb (24 N·m)
Connecting rod bolts (coat threads with engine oil)	M7	16.5 ft-lb (23 N·m)
Flywheel retaining nut	M18	100 ft-lb (135 N·m)
Crankcase cover to block bolts	M8	22 ft-lb (31N·m)
Starter/generator bracket to block bolts	M8	16.5 ft-lb (23 N·m)
Oil drain plug	M14	16.5 ft-lb (23 N·m)
Fan housing screws	M6	90 in-lb (10 N·m)
Fan shroud screws	M6	25 in-lb (2.8 N·m)
Bolts marked with "4" (when used with nuts)	M8	130 in-lb (15 N·m)
	M6	50 in-lb (5.9 N·m)
	M5	30 in-lb (3.4 N·m)

ADJUSTMENTS AND SETTINGS

ITEM	LIMITS
Spark plug gap (standard)	0.027 to 0.031 in. (0.69 to 0.79 mm)
Ignition coil air gap (standard)	0.012 in. (0.304 mm)
Oil pressure (min.) at fast idle speed	45.5 psi. (314 kPa)
Oil filter: bypass-valve opening pressure	11.4 to 17.0 psi. (78 to 118 kPa)
Compression pressure (min.) (with automatic compression release)	71 psi. (483 kPa)
Crankcase vacuum (min.) at fast idle speed	1.18 in. (30 mmHg)
Cylinder head-gasket surface flatness (max.)	0.002 in. (0.05 mm)
ACR lift (standard)	0.059 in. (1.5 mm)
ACR lift (min.)	0.0354 in. (0.9 mm)
Engine rpm	3800 (±30) RPM

SECTION 14 – FUEL SYSTEM

⚠ DANGER

- *Gasoline – Flammable! Explosive! Do not smoke. Keep sparks and flames away from vehicle and service area. Service only in a well-ventilated area.*
- *Do not operate gasoline vehicle in an enclosed area without proper ventilation. The engine produces carbon monoxide, which is an odorless, deadly poison.*
- *Use caution when working under bed. Be sure prop rod is secure; otherwise the bed will fall, resulting in severe personal injury or death.*

⚠ WARNING

- Only trained technicians should repair or service this vehicle. Anyone doing even simple repairs or service should have knowledge and experience in electrical and mechanical repair.
- Follow the procedures exactly as stated in this manual, and heed all DANGER, WARNING, and CAUTION statements in this manual as well as those affixed to the vehicle.
- Wear safety glasses or approved eye protection while servicing vehicle. Wear a full face shield and rubber gloves when working with batteries.
- Turn key switch OFF, remove the key, and place Forward/Reverse handle in the NEUTRAL position and remove key before servicing the vehicle.
- Moving parts! Do not attempt to service the vehicle while it is running.
- Use insulated tools when working near batteries or electrical connections. Use extreme caution to avoid shorting of components or wiring.
- Frame ground – Do not allow tools or other metal objects to contact frame when disconnecting battery cables or other electrical wiring. Never allow a positive wire to touch the vehicle frame, engine, or any other metal component.
- To avoid unintentionally starting the vehicle:
 - Disconnect battery cables, negative cable (–) first.
 - Disconnect the spark plug wire from the spark plug.
- The prop rod on the vehicle should be securely engaged prior to servicing. Remove all cargo before raising the bed. Do not disengage prop rod until all persons are clear of cargo bed area. Do not drop cargo bed; lower gently and keep entire body clear. Failure to follow these instructions could result in severe injury.
- Lift only one end of the vehicle at a time. Before lifting, set the park brake when lifting the front of the vehicle, unload the cargo bed, and chock the wheels that remain on the floor. Use a suitable lifting device (chain hoist or hydraulic floor jack) with 1000 lb. (454 kg) minimum lifting capacity. Do not use lifting device to hold vehicle in raised position. Use approved jack stands of proper weight capacity to support the vehicle.

GENERAL INFORMATION

The engine is equipped with a float bowl type carburetor with fixed jets that require no adjustment. The carburetor atomizes the fuel, mixes it with air, and feeds the combustible mixture into the cylinder.

HOW THE CARBURETOR WORKS

MAIN SYSTEM

The main system of the carburetor consists of the main jet, the main nozzle, and the main air passage. The main system meters fuel to the engine during moderate to heavy load conditions. Fuel flows through the main jet and into the main nozzle, where it meets air from the main air passage. The resulting mixture flows out the end of the main nozzle and into the carburetor bore, where it is atomized by high-speed air flow and then carried into the engine (**Figures 14-1, 14-2 and 14-3, beginning on page 14-2**).

During the intake stroke of the engine, a negative pressure (vacuum) is created in the venturi of the carburetor. In this venturi tube, the intake air has high velocity and low static pressure. Subsequently, fuel is drawn out of the carburetor float chamber, atomized to fine particles, then drawn into the cylinder as a combustible mixture (**Figure 14-2, Page 14-2**).

Trouble in the main system is usually indicated by poor performance, or lack of power under heavy load conditions. A dirty or clogged main jet will cause the mixture to become too lean. An overly rich mixture could be caused by a clogged air passage, clogged air holes in the main nozzle, a loose main jet, or by a loose main nozzle.

If the engine exhibits symptoms of overly rich or lean fuel mix after all maintenance and adjustments are correctly performed, the main jet should be replaced. A smaller numbered jet gives a leaner mixture and a larger numbered jet gives a richer mixture. It is recommended that any change be limited to one jet size difference from the standard jet.

STANDARD JETTING

Pilot Air Screw	Middle of Travel
Pilot Jet	45 (x1/100)
Main Jet	82 (x1/100)
Throttle Valve Stop Screw	1200-1250 RPM

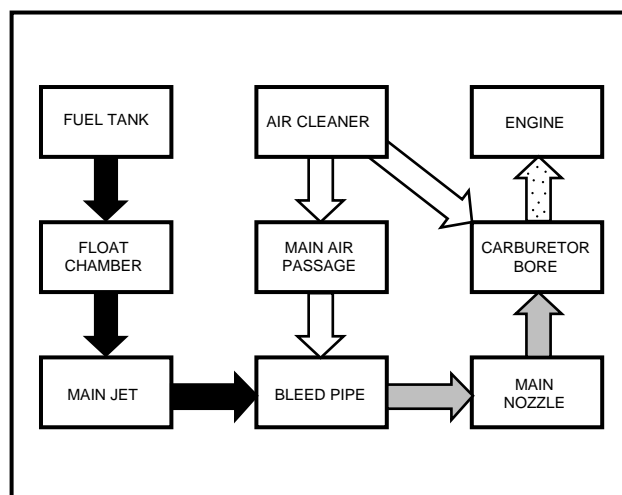

Figure 14-1 Fuel Flow Sequence

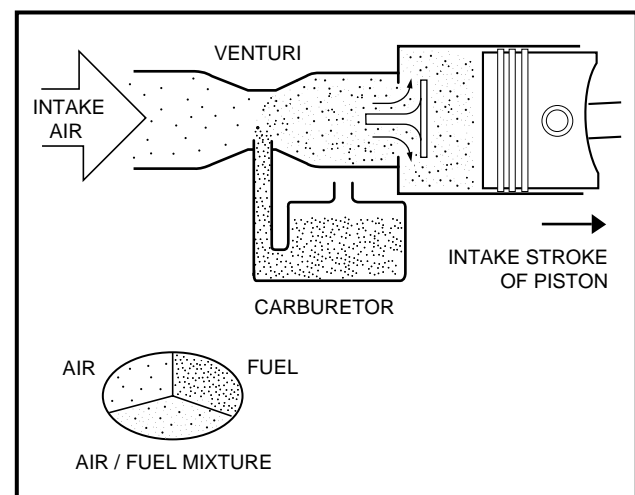

Figure 14-2 Air/Fuel Mixture

SLOW SPEED SYSTEM

The slow speed system supplies fuel during low speed running. Low speed running without load requires very low intake airflow. The throttle valve (**Figure 14-3, Page 14-3**) is almost closed when this is the case, and as high negative pressure is created on the back side of the throttle valve, intake air is drawn in and

metered through the pilot air jet. The intake air draws fuel, metered by the pilot jet (Figure 14-3, Page 14-3), from the carburetor float chamber. The combustible mixture of air and fuel is then delivered into the venturi through the pilot outlet and bypass. When the engine is operating at low speed, fuel is supplied mainly through the pilot outlet (Figure 14-3, Page 14-3).

The air/fuel mixture is adjusted by the pilot screw (needle valve) (Figure 14-3, Page 14-3).

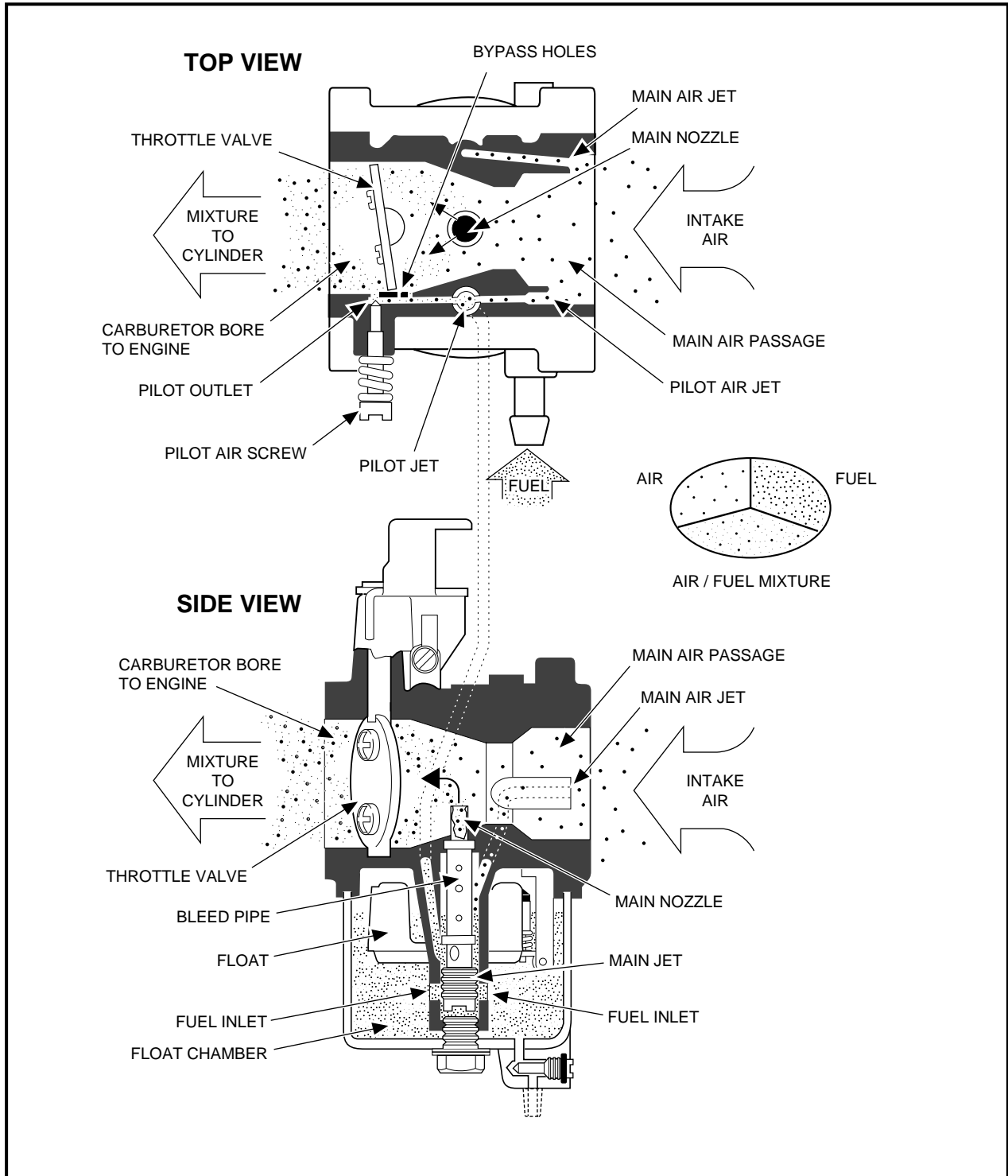

Figure 14-3 Carburetor

CHOKE AND FRESH AIR SYSTEM

The choke system aids in starting the engine in cold weather. When starting a cold engine, the choke cable handle (1) (**Figure 14-4, Page 14-4**) is pulled. This restricts the air flow to the venturi, causing a very high vacuum that draws fuel into the venturi at a high rate and thus creates a “fuel rich” mixture. The choke handle is pulled until the engine starts, and then released when the engine begins to run smoothly.

An air duct provides the engine with clean, cool air from outside the engine compartment. This feature increases engine horsepower and greatly extends air filter life.

FLOAT SYSTEM

The carburetor is a float bowl type, with the float chamber located just below the carburetor body. The float system keeps the fuel in the float chamber at the correct level while the engine is running (**Figure 14-5, Page 14-4**).

Fuel is supplied to the carburetor float chamber by an external impulse pump that draws fuel from the fuel tank and through the fuel filters (**Figure 14-4, Page 14-4**). The fuel then passes through the inlet valve (5) and into the float bowl. The fuel entering the bowl causes the float (4) to rise until it shuts off the inlet valve, preventing the fuel from exceeding a level predetermined by the float level setting.

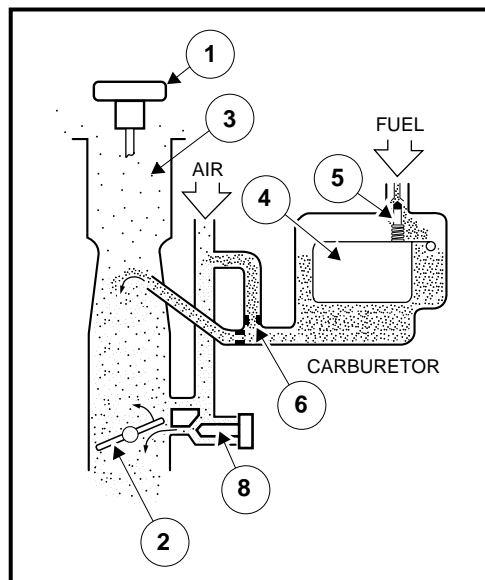

Figure 14-4 Choke System

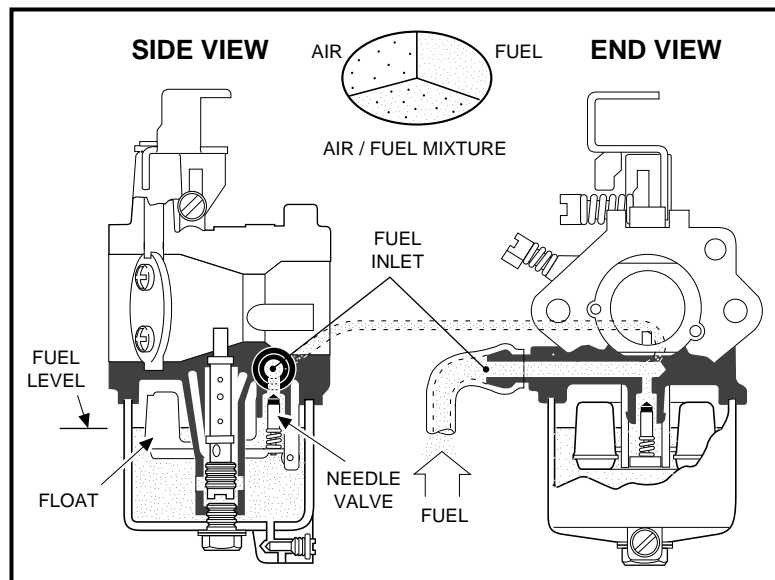

Figure 14-5 Float System

CARBURETOR

Read **DANGER** and **WARNING** on page 14-1.

Before suspecting the carburetor as the cause of poor engine performance, make sure the fuel and ignition systems are in proper operating condition. Check the following items:

- Spark plug and gap condition. **See Spark Plug, Section 13, Page 13-6.**
- Air filter element. **See Air Filter on page 14-18.**
- Fuel filters. **See Fuel Filters on page 14-19.**
- Choke and air intake system (for restriction of air flow). **See Choke and Air Intake System on page 14-14.**
- Fuel pump. **See Fuel Pump on page 14-21.**

- Fuel lines (from fuel tank to filter to pump to filter to carburetor). **See Fuel Lines on page 14-27.**
- Exhaust system (for restrictions). **See Section 15 – Exhaust System.**

If the carburetor floods or leaks fuel at the float bowl gasket or carburetor vent tube, the fuel inlet valve could be worn or dirty. Another cause of this condition may be a damaged float that has filled with fuel and sinks.

For elevations above 3000 feet, main jets other than standard operate more effectively. The following chart lists the elevation ratings for various jet sizes. No adjustment is required for the pilot jet. If the vehicle idles roughly, turn the pilot air screw (**Figure 14-3, Page 14-3**) out until the vehicle idles smoothly.

MAIN JET ELEVATION/SIZE CHART

ALTITUDE	FE350 ENGINE MAIN JET SIZE
0-3000 ft. (0-914.4 m)	85
3000-5000 ft. (914.4-1524 m)	82
500-8000 ft. (1524-2438.4 m)	80
8000-10,000 ft. (2438.4-3048 m)	78
10,000 ft. and over (3048 m and over)	75

CHANGING THE MAIN JET

Read **DANGER** and **WARNING** on page 14-1.

1. Remove the carburetor (**Figure 14-6, Page 14-6**).
 - 1.1. Access engine compartment.
 - 1.2. Turn fuel shut-off valve on gas tank to the closed (OFF) position.
 - 1.3. Loosen the intake air hose clamp (22) and disconnect the intake air hose (23) at the carburetor end only.
 - 1.4. Remove the governor cable cotter pin (25) and clevis pin (24) (carburetor end only).
 - 1.5. Disconnect the carburetor vent line (14).
 - 1.6. Disconnect the fuel supply line (26) at the carburetor end only. Temporarily plug the end of the fuel line to prevent fuel leakage.
 - 1.7. Remove the carburetor retaining nuts (19), intake pipe (17), and carburetor (12). **See following NOTE.**

NOTE: Note the orientation of the gasket (16), between the carburetor intake pipe (17) and the carburetor body (12) so that it can be replaced in the same orientation (**Figure 14-6, Page 14-6**).

When removing the carburetor body, the throttle return spring (11) must be disconnected. Note its proper orientation so that it can be replaced with the same orientation.

The carburetor must be kept upright during removal.

2. Position the carburetor with the drain screw (11) over a catch basin (**Figure 14-7, Page 14-7**).

Changing the Main Jet, Continued:

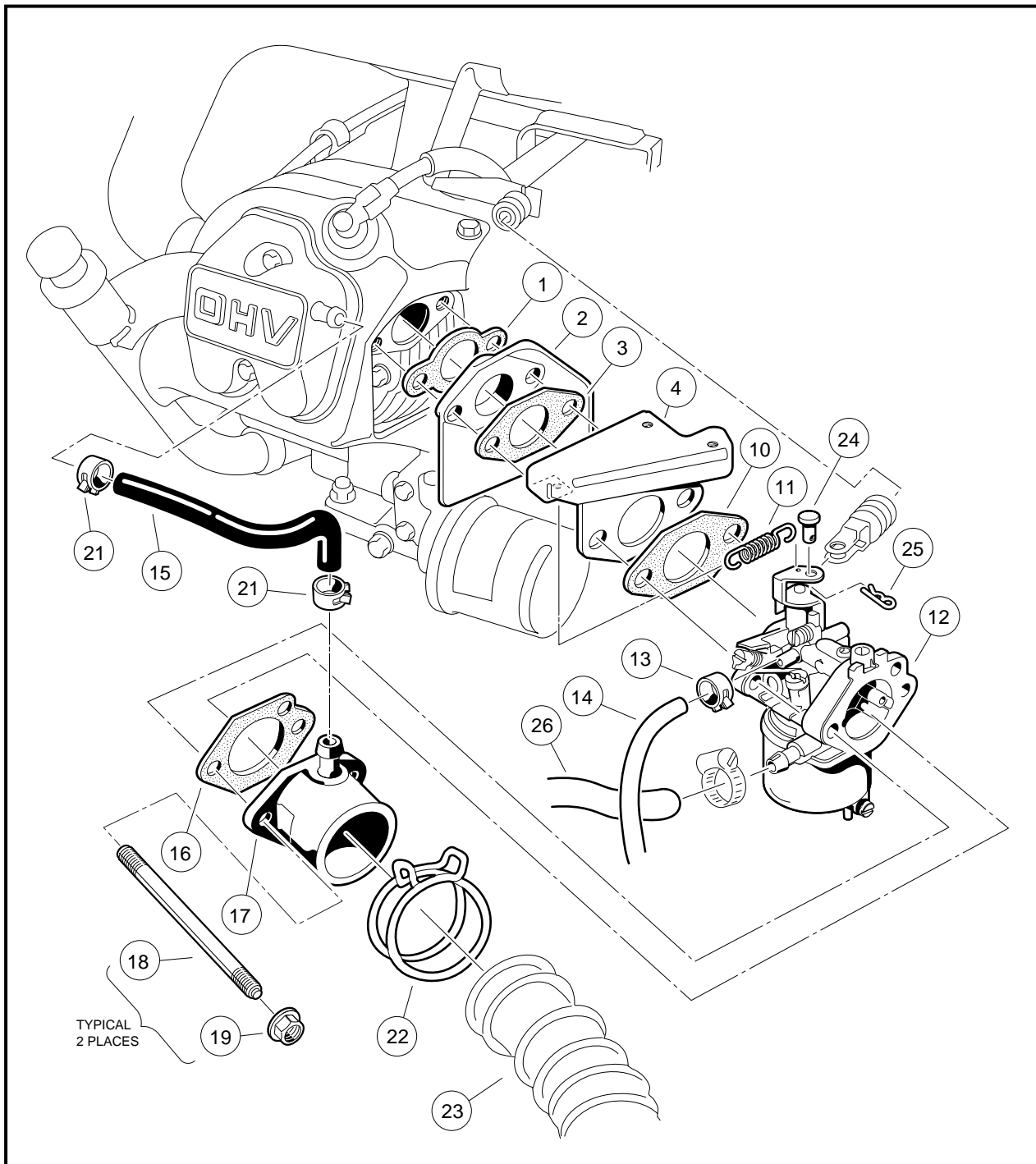

Figure 14-6 Carburetor Installation

3. Turn the carburetor bowl drain screw counterclockwise two or three turns and drain all the fuel from the bowl into the catch basin (**Figure 14-7, Page 14-7**). Tighten the drain screw to 10 in-lb (1.1 N-m). Return fuel to the gas tank or dispose of properly.
4. Mark the body of the carburetor and the carburetor fuel bowl with an indelible ink marker so that, after removal, the bowl can be installed again in the same position (**Figure 14-7, Page 14-7**).

- Remove the carburetor fuel bowl retaining screw and washer (12), then remove the fuel bowl (10) and clean it with a nonflammable solvent (**Figure 14-7, Page 14-7**). **See following NOTE.**

NOTE: Make sure the fuel bowl gasket (9) remains properly seated in the carburetor body when the fuel bowl is removed (**Figure 14-7, Page 14-7**).

During normal operation, the fuel bowl retains the float pivot pin (6). Make sure that the float pivot pin does not fall out of the carburetor body after the fuel bowl is removed.

- Remove the main jet (8) from the carburetor body and discard it (**Figure 14-7, Page 14-7**).

NOTE: Make sure the fuel nozzle (7) does not fall out of the carburetor body after removal of the main jet. This is best accomplished by positioning the carburetor upside down during main jet removal (**Figure 14-7, Page 14-7**).

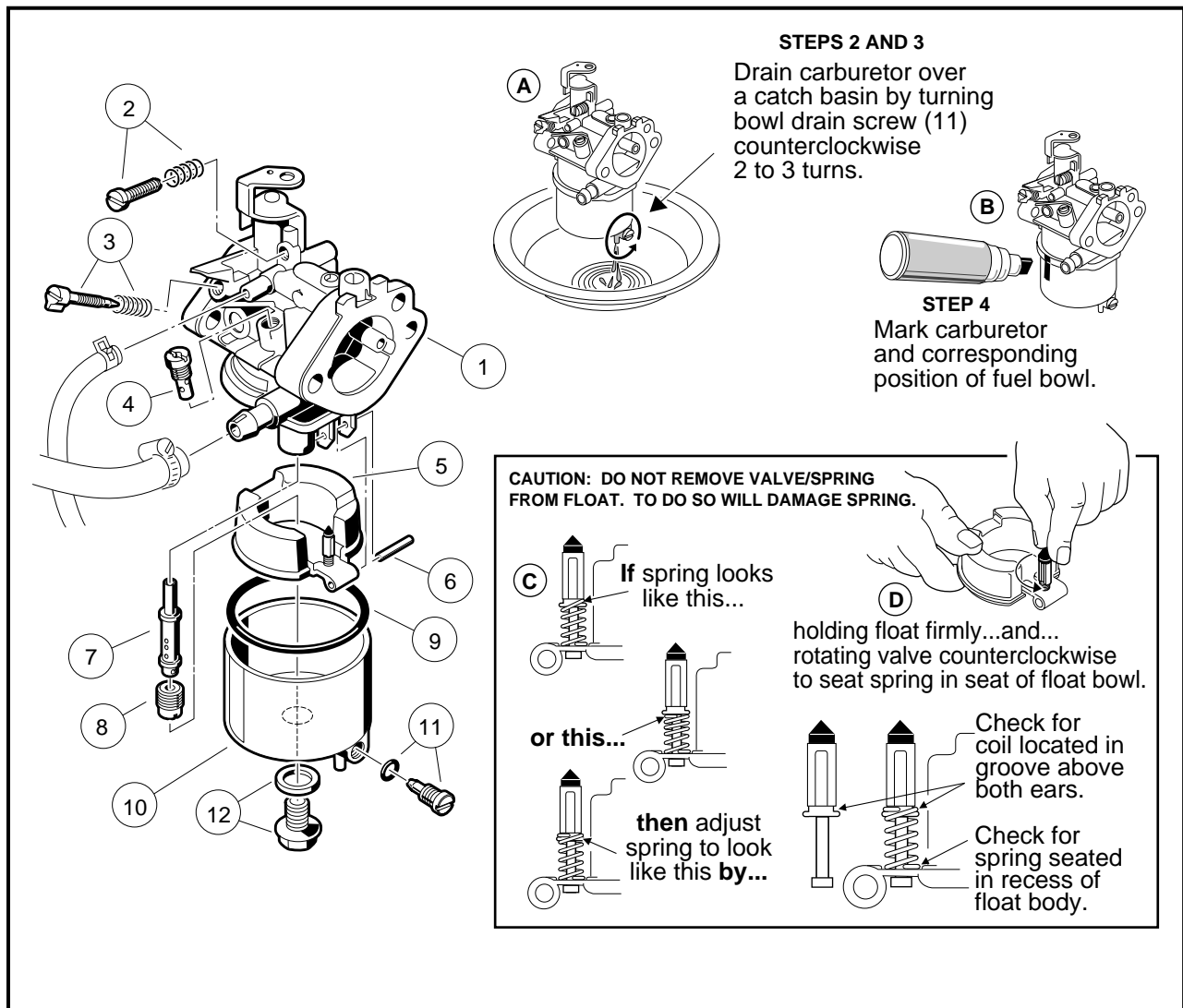

Figure 14-7 Changing the Main Jet

- Select the proper size main jet. **See chart on page 14-5.** Check the size designation on the jet to make sure it is the correct part.
- Install the new main jet and tighten it to 12 in-lb (1.4 N·m). **See following CAUTION and NOTE.**

Changing the Main Jet, Continued:**⚠ CAUTION**

- Do not remove the valve/spring assembly from the float assembly. Doing so will damage the spring.

NOTE: Inspect the main jet nozzle (7), and pilot jet (4) to ensure they are free from contamination. Replace any part that is clogged with contamination. Replace the float if it is damaged, or if the float valve is damaged or worn. Examine the float valve/spring assembly to make sure the spring is installed correctly (**Figure 14-7, Page 14-7**).

9. Install the fuel bowl. Make sure that it is positioned properly by aligning the marks applied in step 4. **See following CAUTION.**

⚠ CAUTION

- Make sure the fuel bowl is properly seated against the carburetor fuel bowl gasket, and the gasket is not pinched.

10. Install the fuel bowl retaining screw and tighten it to 61 in-lb (6.9 N·m).
11. Write the size of the main jet on the fuel bowl with an indelible ink marker. This should be written in a location that will be visible when the carburetor is installed on the engine.
12. Install the carburetor on the engine (**Figure 14-6, Page 14-6**).
 - 12.1. Attach the throttle return spring (11) to the carburetor and then to the throttle bracket (4) just before positioning the carburetor and securing it to the engine (**Figure 14-6, Page 14-6**).
 - 12.2. Install the intake pipe gasket (16) (check for proper orientation) and intake pipe (17) (**Figure 14-6, Page 14-6**).
 - 12.3. Install the carburetor retaining nuts (19) and tighten them to 50 in-lb (5.7 N·m) (**Figure 14-6, Page 14-6**).
13. Connect fuel supply line (26) and tighten screw clamp to 9 in-lb (1.0 N·m) (**Figure 14-6, Page 14-6**).
14. Install carburetor vent line (14) and clamp (13) (**Figure 14-6, Page 14-6**).
15. Install the governor cable clevis pin (24) and cotter pin (25) (**Figure 14-6, Page 14-6**).
16. Install the intake hose (23) and secure with hose clamp (**Figure 14-6, Page 14-6**).

NOTE: Make sure the intake hose is not twisted during installation.

17. Turn fuel shut-off valve (on gas tank) to the ON position (**Figure 14-22, Page 14-28 and Figure 14-23, Page 14-28**).
18. Connect the battery cables, positive (+) post first, and tighten terminals to 20 ft-lb (27.1 N·m).
19. Test drive the vehicle.

ENGINE CONTROL LINKAGE

Read **DANGER** and **WARNING** on page 14-1.

GENERAL INFORMATION

For proper vehicle operation, it is important the accelerator pedal, governor linkage, and throttle adjustments are done correctly and in the proper sequence. **See following CAUTION.**

▲ CAUTION

- *Improper adjustment can result in poor vehicle performance and/or damage to the engine components.*

ACCELERATOR ROD

▲ DANGER

- **To ensure the vehicle does not run over you while you disconnect or adjust the accelerator push rod, do the following:**
 - Turn key switch OFF, place Forward/Reverse handle in the NEUTRAL position, and remove key before servicing the vehicle.
 - Disconnect battery cables, negative cable (-) first.
 - Disconnect the spark plug wire from the spark plug.

Accelerator Rod Removal

1. Raise the front of the vehicle. Place chocks at the rear wheels and lift the front of the vehicle with a chain hoist or floor jack. Place jack stands under the round frame cross tube to support the vehicle. **See preceding DANGER. See also WARNING on page 14-1.**
2. Remove the accelerator rod by disconnecting the ball joint (1) from the ball stud (2) on the accelerator pedal (**Figure 14-8, Page 14-9**) and from the bell crank at the electrical box (**Figure 14-10, Page 14-11**).

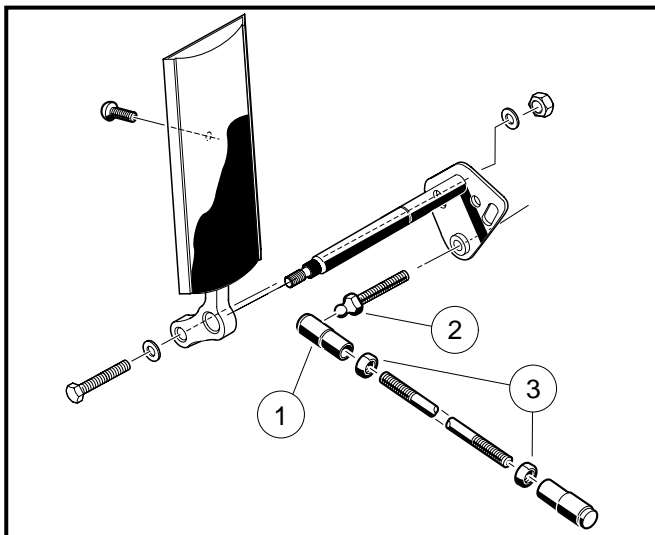

Figure 14-8 Accelerator Rod

Accelerator Rod Installation and Adjustment

1. Before installing the accelerator rod, adjust accelerator pedal position. **See Accelerator Pedal Adjustment, Section 5, Page 5-3.**
2. Install the ball joint on the ball stud at the accelerator pedal (**Figure 14-8, Page 14-9**).
3. Access the engine compartment. **See DANGER on page 14-1.**
 - 3.1. Tilt the bed and ensure that the prop rod is engaged.

Accelerator Rod Installation and Adjustment, Continued:

4. Remove the electrical box screw and cover. **See preceding DANGER.**
5. Adjust length of accelerator rod. With the ball joint jam nuts (3) loose (**Figure 14-8, Page 14-9**), adjust the length of the rod so the indicated cam edge is parallel with the edge of the electrical component box as shown (**Figure 14-9, Page 14-11**). **See following CAUTION.**

 CAUTION

- *After accelerator rod adjustment, make sure that approximately the same number of threads are exposed at each end of the accelerator rod.*
6. Install the accelerator rod on the bell crank ball joint on the electrical box (**Figure 14-10, Page 14-11**).
 7. Before tightening the jam nuts, check for proper accelerator rod operation.
 8. While pressing the accelerator pedal, the carburetor throttle should begin to move when the pedal is depressed approximately 8° to 12°.
 9. While holding the accelerator ball joint with pliers, tighten the jam nuts against the ball joints, accelerator ball joint first, at each end of the accelerator rod.
 10. After the accelerator pedal and rod are properly adjusted, adjust the engine RPM setting. **See Engine RPM Adjustment on page 14-13.**
 11. Install the electrical box cover and tighten retaining screw to 18 in-lb (2.0 N·m).

GOVERNOR CABLE**Governor Cable Removal**

1. Access the engine compartment. **See DANGER on page 14-1.**
 - 1.1. Tilt the bed and ensure that the prop rod is engaged.
2. Remove the cotter pin (25) and clevis pin (24) at the carburetor throttle bracket (**Figure 14-6, Page 14-6**).
3. Remove the E-ring (7) at the governor cable engine bracket (11), and governor cable support bracket (10) (**Figure 14-11, Page 14-12**).
4. Remove the cotter pin (9) and clevis pin (8) from the governor lever arm (15) (**Figure 14-11, Page 14-12**).
5. Remove the cable (2) (**Figure 14-11, Page 14-12**).

Governor Cable Installation and Adjustment

1. Install the cable onto the governor cable support bracket (10) and the engine bracket (11) and attach an E-ring (7) at each end (**Figure 14-11, Page 14-12**).
2. Push the cable dust shields onto the ends of the cable conduit.
3. Install governor cable end into carburetor throttle clevis and install clevis pin (8) and cotter pin (9) (**Figure 14-11, Page 14-12**).
4. Install governor cable clevis over governor lever arm and install clevis pin (8) and cotter pin (9) (**Figure 14-11, Page 14-12**).

5. With the governor lever arm loose on the governor shaft, use a 1/8 inch punch or scratch awl to turn the governor arm shaft counterclockwise until it stops. Then pull the governor lever arm rearward until the carburetor throttle is in the “wide open throttle” (WOT) position.
6. While holding the arm and shaft in the fully counterclockwise position, tighten the governor arm lever nut to 36 in-lb (4.0 N·m).
7. Check engine RPM adjustment. **See Engine RPM Adjustment on page 14-13.**

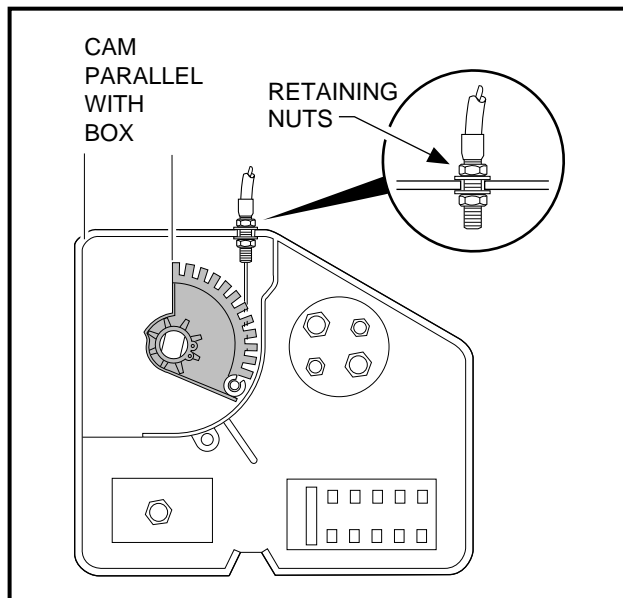

Figure 14-9 Cam Position

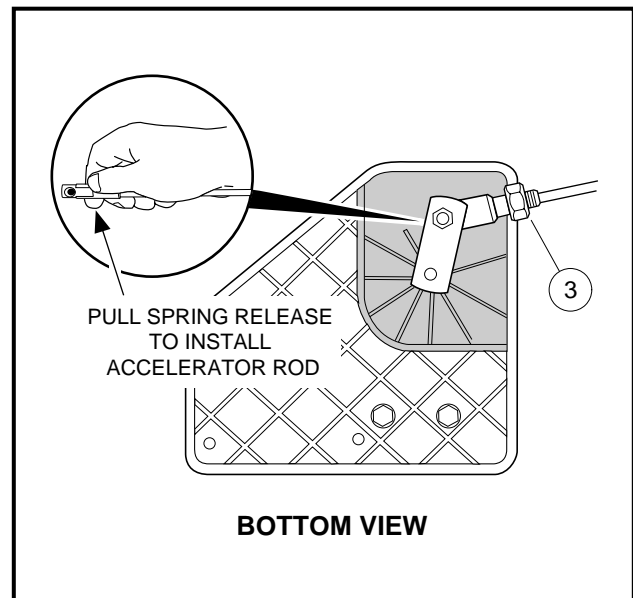

Figure 14-10 Accelerator Rod

ACCELERATOR CABLE

Accelerator Cable Removal

1. Access the engine compartment. **See DANGER on page 14-1.**
 - 1.1. Tilt the bed and ensure that the prop rod is engaged.
2. Remove the electrical box cover and loosen the cable housing retaining nuts (**Figure 14-9, Page 14-11**).
3. Disconnect cable (1) from cam (17) in the electrical box (**Figure 14-11, Page 14-12**).
4. Remove the E-ring (7) on the spring end of the cable at the accelerator cable bracket (5) (**Figure 14-11, Page 14-12**). Pull the cable housing out of the bracket.
5. Disconnect the spring (16) from the engine governor arm by rotating the arm counterclockwise one-half turn. Remove the cable assembly from the vehicle (**Figure 14-11, Page 14-12**).

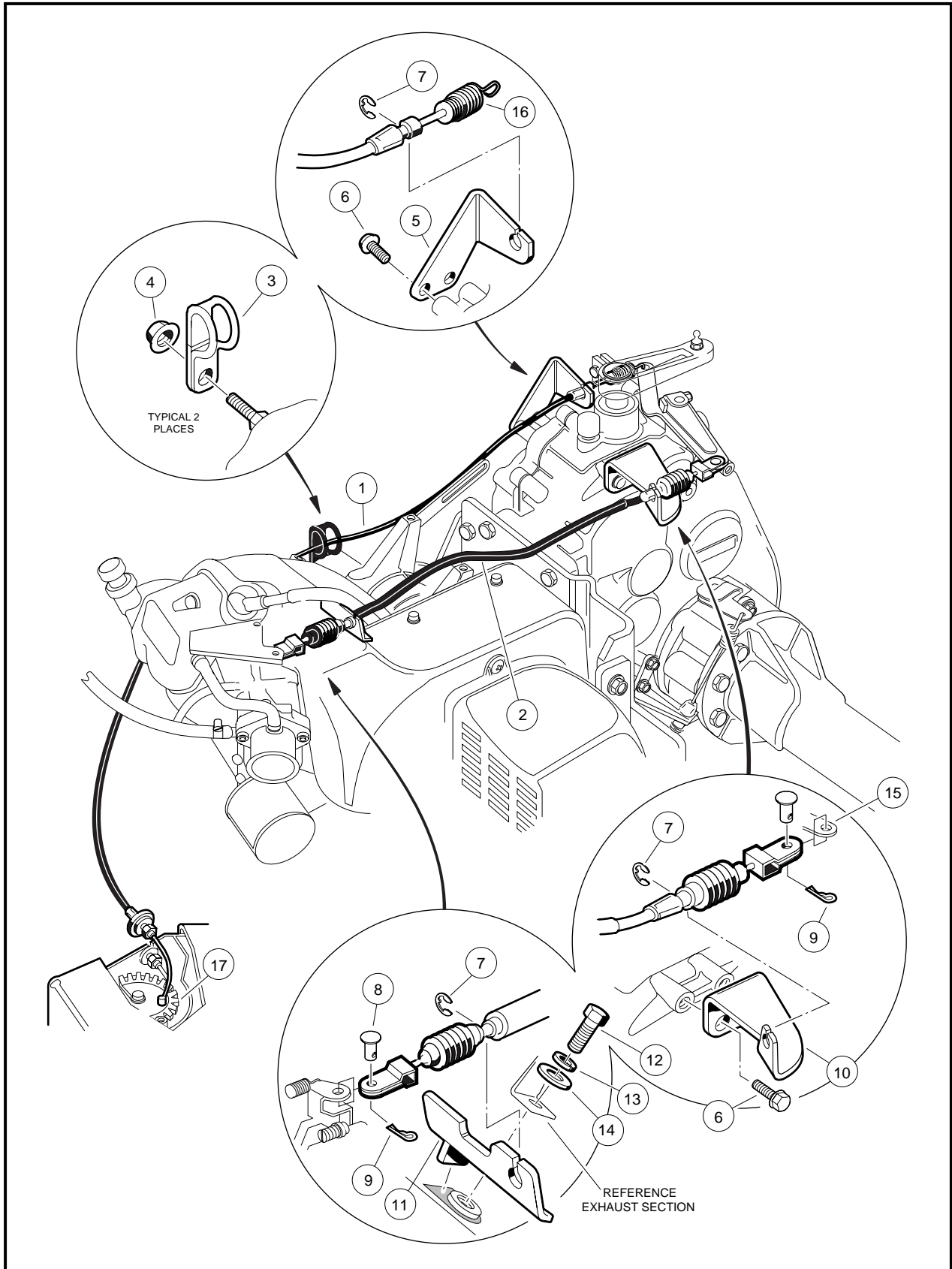

Figure 14-11 Governor and Accelerator Cables

Accelerator Cable Installation

1. Connect the cable to the cam (17) in the electrical box (**Figure 14-11, Page 14-12**).
2. Insert the cable housing into the mounting slot in the wall of the electrical box, with approximately the same number of threads visible between the jam nuts as are visible from the nut inside the box to the end of the cable housing (**Figure 14-9, Page 14-11**). Tighten the nuts finger tight.
3. Connect the spring (16) to the engine governor arm (**Figure 14-11, Page 14-12**).
4. Install cable in accelerator cable bracket (5) and secure it with E-ring (7) (**Figure 14-11, Page 14-12**).
5. Push the cable dust shield onto the spring end of the cable conduit (**Figure 14-11, Page 14-12**).
6. Before tightening the cable housing retaining nuts, make sure the engine RPM adjustment is correct. **See Engine RPM Adjustment on page 14-13.**
7. Install the electrical box cover, and tighten the retaining screw to 18 in-lb (2.0 N·m).

CLOSED THROTTLE OR IDLE ADJUSTMENT

1. With the engine running and the Forward/Reverse handle in NEUTRAL, attach a tachometer (CCI 1016112) to the spark plug wire and adjust the idle screw on the carburetor until the tachometer reads 1200 to 1250 RPM (**Figure 14-12, Page 14-13**).

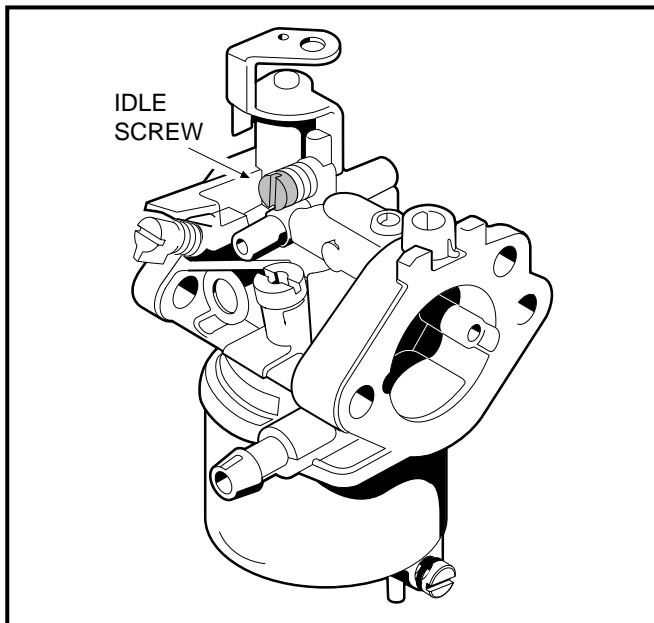

Figure 14-12 Idle Screw

ENGINE RPM ADJUSTMENT

⚠ DANGER

- **The engine produces carbon monoxide, which is an odorless and deadly poison. Do not operate the engine in an enclosed area without proper ventilation.**

1. If the governor is adjusted, proceed to step 2; otherwise, adjust the governor. **See Governor Cable Installation and Adjustment on page 14-10.**

Engine RPM Adjustment, Continued:

2. Connect the battery cables, positive (+) cable first. Tighten terminals to 20 ft-lb (27.1 N·m).
3. Place the Forward/Reverse handle in the NEUTRAL position and chock the wheels.
4. Connect a tachometer (CCI 1016112) to the spark plug lead.
5. With the tachometer connected, and the engine at normal operating temperature, check high speed RPM. With the accelerator pedal pressed to the floor, the tachometer should read 3800 (± 30) RPM.
6. To **reduce** RPM, loosen the accelerator cable retaining nut on the outside of the electrical box wall and tighten the retaining nut on the inside of the wall until the specified RPM is reached (**Figure 14-9, Page 14-11**). To **increase** RPM, loosen the cable retaining nut inside the electrical box and tighten the nut outside the box until the desired RPM is reached.
7. Be sure both retaining nuts are locked against the electrical box and then check the RPM again. If the RPM needs to be adjusted, repeat step 5.
8. If more adjustment is required than the cable housing will allow, make sure the spring on the other end of the accelerator cable is properly positioned. Excessive belt and torque converter wear can also prevent proper RPM adjustment. Check them for excessive wear. **See Section 17 – Torque Converter.**

CHOKE AND AIR INTAKE SYSTEM

Read **DANGER** and **WARNING** on page 14-1.

GENERAL INFORMATION

The choke system is a simple mechanism requiring very little or no maintenance. The system consists of a choke assembly that is attached to the driver side of the front body, an air filter housing with a hose that is attached to the carburetor, and an air duct that provides the engine with air from outside the engine compartment. Clean, cool air is drawn through the choke assembly and into the air cleaner intake. This feature increases engine horsepower and extends air filter life.

The choke system aids in starting the engine in cold weather. When starting a cold engine, the choke cable handle is pulled. This restricts the air flow, creating a “fuel rich” mixture in the carburetor. The choke cable handle is pulled until the engine starts, and then is released. The air flow to the engine is no longer restricted, and the engine operates normally.

The choke assembly is adjusted at the factory and does not require field adjustment. However, if the choke assembly is subjected to abuse or damaged, it may become necessary to replace the assembly.

CHOKE CABLE REMOVAL

1. Remove the screw (17) securing cable to air box and detach cable end from choke lever (6) (**Figure 14-14, Page 14-17**).
2. Remove three screws (19), nuts (21) and washers (20) from body and remove choke cable assembly from body (**Figure 14-14, Page 14-17**).

CHOKE CABLE INSTALLATION

1. Insert choke cable through hole in body until choke lever assembly seats against body.
2. Install three screws (19), washers (20), and locknuts (21) as shown and tighten to 18 in-lb (2.0 N·m) (**Figure 14-14, Page 14-17**).

3. Check the hex nut on the cable at the back of the choke lever assembly. If it is loose, tighten it until the lock washer beside it collapses completely.
4. Attach choke cable to choke lever (6) on air box. Install screw (17) to secure cable to air box and tighten to 18 in-lb (2.0 N·m) (**Figure 14-14, Page 14-17**).

AIR BOX REMOVAL

1. Access the engine compartment. **See DANGER on page 14-1.**
 - 1.1. Tilt the bed and ensure that the prop rod is engaged.
2. Remove the air intake box from the vehicle by removing intake hose (16) and three screws (23) and washers (22) that mount the intake box to the vehicle (**Figure 14-14, Page 14-17**).

AIR BOX INSTALLATION

NOTE: The intake duct must be in place before the air box can be installed.

1. Check to be sure the intake seal (13) is seated correctly (**Figure 14-14, Page 14-17**). The seal fits tightly onto the bottom side of the air box. If seal is not in place, moisture will enter the air intake system.
2. Place the air box assembly into vehicle and install three flat washers (22) and screws (23) from underside of air box mounting plate into air box (**Figure 14-14, Page 14-17**). Tighten to 33 in-lb (3.7 N·m).
3. Place hose onto air box and secure with wire clamp.
4. Attach the choke cable to the air box top. **See Choke Cable Installation on page 14-14.**
5. Test choke for proper operation.

INTAKE DUCT REMOVAL

1. Remove the front body. **See Front Body Removal, Section 4, Page 4-3.**
2. Slightly loosen the lug nuts on the front driver side wheel.
3. Place wheel chocks in front of the two rear wheels and raise the front of the vehicle with a floor jack.
4. Place jack stands under the vehicle frame to support the front of the vehicle with the front wheels off of the ground and lower the vehicle onto the jack stands.
5. Remove the lug nuts from the front driver side wheel and remove the wheel.
6. Remove the bolt that connects the steering joint (1) to the steering column shaft (**Figure 14-13, Page 14-16**).
7. Disconnect the steering joint from the steering column shaft.
8. Remove the two bolts (26), locknuts and flat washers that secure the strap plate (27) to the vehicle frame (**Figure 14-14, Page 14-17**).
9. Remove the two bolts (28) and nuts that connect the upper shock mounts to the shock tower and strap plate (27) (**Figure 14-14, Page 14-17**).
10. Remove the strap plate (27) (**Figure 14-14, Page 14-17**).
11. Roll the floor mat from underneath the dashboard and drill out the pop rivet (30) that secures the air intake shield (29) to the floorboard.
12. Using a putty knife, gently pry the adhesive strip that holds the shield to the vehicle frame and remove the shield from the vehicle.
13. Drill out the two pop rivets (24) securing the intake duct to the floorboard (**Figure 14-14, Page 14-17**).
14. Remove three screws (23) and flat washers (22) from the bottom of the air box assembly (**Figure 14-14, Page 14-17**).

Intake Duct Removal, Continued:

15. Lift air box assembly off the intake duct. Be careful that the intake seal on the bottom of the air box assembly is not dislodged in the process.
16. Pull the intake duct forward and out of the vehicle.

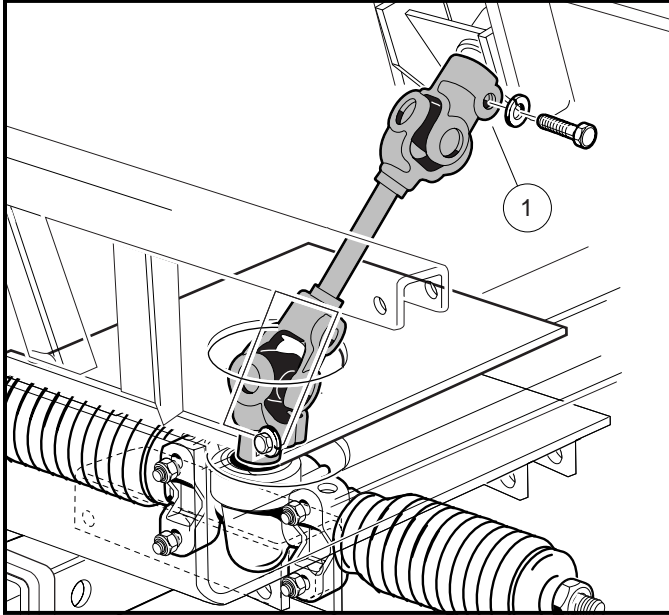

Figure 14-13 Compound Steering Joint

INTAKE DUCT INSTALLATION

The intake duct assembly is installed from the front of the vehicle.

1. Slide the intake duct between the round crossmember and the floorboard, moving it to the rear along the underside of the floorboard. Insert the end of the intake duct through the slot in the front of the air box mounting plate.
2. Secure the front of the duct to the underside of the floorboard with two pop rivets (24) and flat washers (25) (**Figure 14-14, Page 14-17**).
3. Place a piece of double-sided adhesive tape on the intake shield and remove the adhesive backing.
4. Install the shield to the frame with the adhesive strip and a pop rivet (30).
5. Install air box. **See Air Box Installation on page 14-15.**
6. Install steering joint assembly. **See following NOTE.**

NOTE: Make sure steering wheel and front wheels are properly aligned before installing steering joint.

- 6.1. Position steering joint assembly (1) on vehicle as shown. Install three lock washers and three bolts and tighten to 15 ft-lb (20.3 N·m) (**Figure 14-13, Page 14-16**). Make sure all of the steering joint bolts are properly tightened to 15 ft-lb (20.3 N·m).
7. Position the strap plate (27) on the frame and install two bolts (26), flat washers and locknuts. Finger tighten (**Figure 14-14, Page 14-17**).
8. Connect the strap plate (27) and upper shock absorber mounts to the shock tower with two bolts (28) and nuts (**Figure 14-14, Page 14-17**). Tighten the two bolts (28) and nuts to 20 ft-lb (27 N·m) (**Figure 14-14, Page 14-17**).
9. Tighten the two bolts (26) and locknuts to 20 ft-lb (27 N·m) (**Figure 14-14, Page 14-17**).

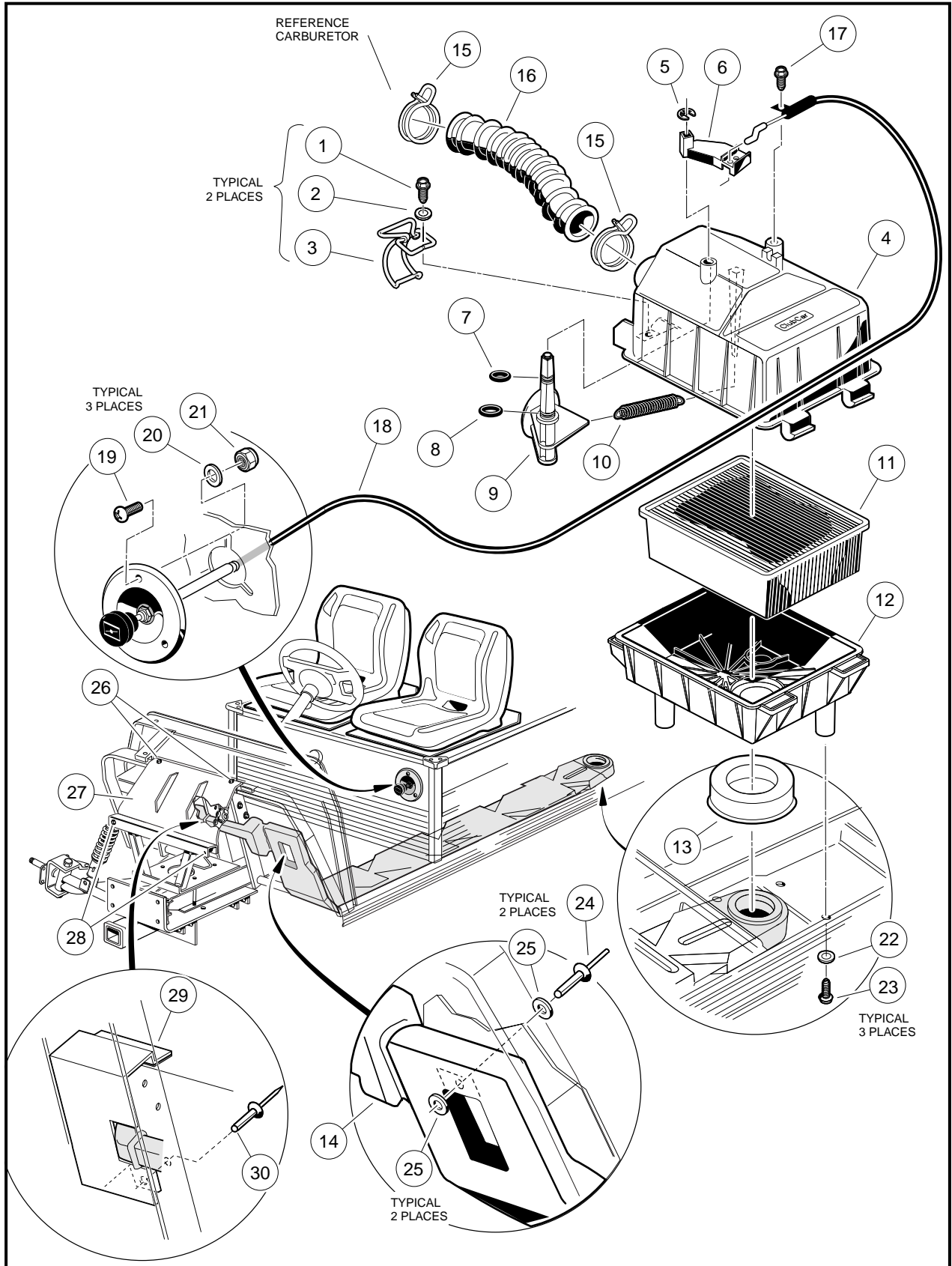

Figure 14-14 Air Intake and Choke Assemblies

Intake Duct Installation, Continued:

10. Install front left wheel. Tighten the wheel lug nuts finger tight.
11. Lower the vehicle and tighten the wheel lug nuts to 55 ft-lb (75 N·m).
12. Install front body.
13. Check for proper operation.

INTAKE DUCT REPAIR

In the event of puncture damage to the intake duct, a repair kit is available (CCI 101971001). This kit is designed to repair small cracks or holes. If the intake duct is badly torn, it will need to be replaced.

AIR FILTER**General Information**

The air filter should be checked every year or 100 hours. More frequent service may be required in extremely dirty operating environments. Need for immediate servicing will be indicated by a loss of power, sluggish acceleration or an engine which runs roughly with excessive black exhaust smoke.

Air Filter Replacement

1. Remove seat and lift bed to access engine compartment.
2. Lift two latches (3) on the side of the air box (**Figure 14-14, Page 14-17**).
3. Remove the hose clamp (15) from the air hose and remove hose from the air box assembly.
4. Standing on driver side of vehicle, grasp air hose mounting inlet and open box fully. Remove filter element (11).
5. Using a clean cloth, wipe away any dust or dirt from inside the air box. Remove all dirt build-up around the inside lip of the box or the box will not seal properly.
6. Install new air filter by inserting back edge first, and pushing down using the palm of your hand to seat filter evenly onto inside lip of air box. Ensure filter fits correctly and that the wire latches are not caught between lid and air box. Close the lid.
7. Fasten wire latches (3). Make sure latches securely engage the bottom half of the box. **See following CAUTION.**

 CAUTION

- Engine damage will occur if the air box cover is not properly secured.
 - If air box is extremely dirty, remove air box from vehicle and clean thoroughly.
 - Use only Club Car replacement air filters (CCI 1015426). The use of other air filters could result in engine damage. If the air filter is too thin, the cover will seat before the filter can seal, leaving space for dirt to pass into the engine on all sides of the element. This will damage the engine and void the warranty.
8. Reinstall hose (16) and hose clamp (15) (**Figure 14-14, Page 14-17**). Make sure clamp ends are located in the 12:00 o'clock position.

FUEL FILTERS

Read **DANGER** and **WARNING** on page 14-1.

GENERAL INFORMATION

Fuel is supplied to the fuel pump and carburetor through flexible lines. Two in-line filters are installed between the fuel tank and the carburetor (**Figure 14-15, Page 14-20**). Fuel filters, fuel lines, and the fuel tank vent should be inspected periodically for leaks.

The fuel filters should be replaced when necessary, but under no circumstance should the period of time between filter changes exceed two years or 200 hours.

FUEL FILTER REMOVAL

1. Access the engine compartment. **See DANGER on page 14-1.**
 - 1.1. Tilt the bed and ensure that the prop rod is engaged.
2. To prevent gasoline drainage, turn the fuel shut-off valve (15) (**Figure 14-15, Page 14-20**) on the gas tank to the closed (OFF) position (**Figure 14-21, Page 14-28**).
3. Remove the primary fuel filter (17) (**Figure 14-15, Page 14-20**):
 - 3.1. Remove the clamps (16) and fuel lines (1) and (2) from the filter and plug the fuel lines (**Figure 14-15, Page 14-20**).
4. Remove the secondary filter (22) (**Figure 14-15, Page 14-20**):
 - 4.1. Remove the clamps (16) and fuel lines (3 and 4) from the filter and plug the fuel lines (3 and 4) (**Figure 14-15, Page 14-20**).

FUEL FILTER INSTALLATION

⚠ CAUTION

- Fuel filters are marked with flow direction arrows. Make sure that filters are installed with arrows pointing in the direction of fuel flow from tank to carburetor.

1. Install the primary fuel filter (17) in the fuel line. Use new clamps (16) (**Figure 14-15, Page 14-20**).
2. Install the secondary fuel filter (22) in the fuel line. Use new clamps (16) (**Figure 14-15, Page 14-20**).
3. Turn the fuel shut-off valve to the ON position (**Figure 14-22, Page 14-28**).
4. Connect the spark plug wire to the spark plug.
5. Connect the battery cables, positive (+) cable first and tighten terminals to 20 ft-lb (27.1 N·m).
6. Place the Forward/Reverse handle in the NEUTRAL position and chock the wheels. Start the engine and check for fuel leaks. **See following DANGER.**

⚠ DANGER

- Repair any fuel leaks before operating the vehicle.

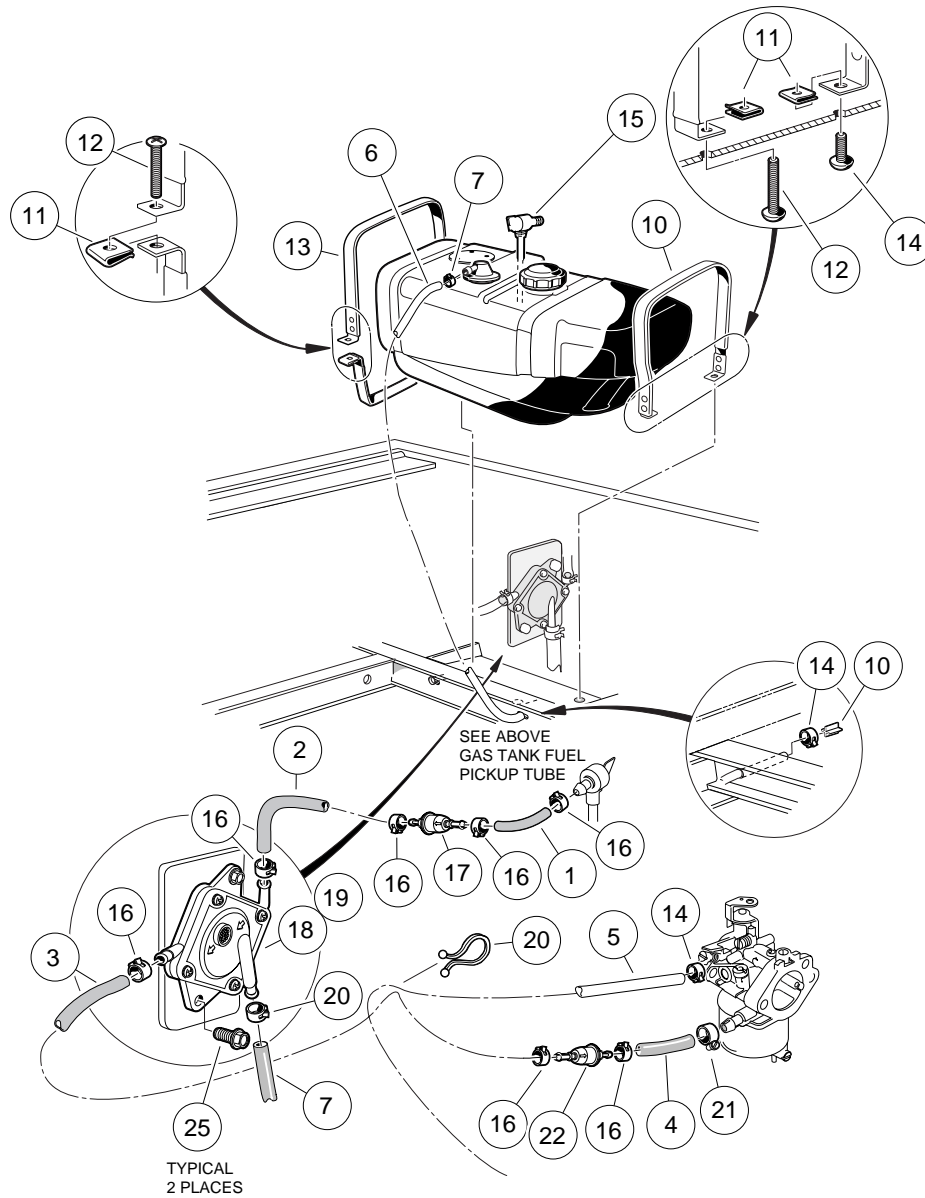

FUEL LINE No.	ROUTING	LENGTH
1	Fuel tank to primary fuel filter	14.0 in. (35.6 cm)
2	Primary fuel filter to fuel pump	6.0 in. (15.2 cm)
3	Fuel pump to secondary fuel filter	11.5 in. (29.2 cm)
4	Secondary fuel filter to carburetor	2.5 in. (6.4 cm)
5	Vent tube (Carburetor)	17.0 in. (43.2 cm)
6	Vent tube (Gas Tank)	17.0 in. (43.2 cm)
7	Impulse line	14.0 in. (35.6 cm)

Figure 14-15 Fuel and Vent Lines

FUEL PUMP

Read **DANGER** and **WARNING** on page 14-1.

GENERAL INFORMATION

The gasoline vehicle is equipped with an impulse fuel pump. If the fuel pump is not operating properly, perform the following tests:

- Make sure all hose clamps are tight.
- Inspect the impulse line and fuel lines for damage or clogging.
- Make sure the air vent on the fuel pump is not clogged with dirt.
- Make sure the fuel filters are not clogged.

To clean the air vent, the fuel pump must be disassembled.

FUEL PUMP REMOVAL

1. Turn fuel shut-off valve on top of the gas tank to the closed (OFF) position (**Figure 14-21, Page 14-28**).
2. Remove hardware attaching the fuel pump (18) and lift the fuel pump out of the engine compartment (**Figure 14-15, Page 14-20**).
3. Remove the clamp (20) and impulse line (7) from fuel pump (**Figure 14-15, Page 14-20**).
4. Disconnect the fuel lines (2 and 3) from the pump and plug them to prevent gasoline leakage (**Figure 14-15, Page 14-20**). See following **WARNING**.

⚠ WARNING

- Carefully drain any fuel remaining in the pump into a container. Add drained fuel back into gas tank or dispose of properly.

FUEL PUMP DISASSEMBLY

NOTE: A fuel pump rebuild kit is available from Club Car (CCI 1014524). This kit includes all gaskets, diaphragms, and valves.

1. Remove four screws (24) and lock washers (25) from front of the fuel pump (**Figure 14-16, Page 14-22**).
2. Remove the front cover of the fuel pump while holding the rest of the pump intact.
3. Note the orientations of the impulse gasket (27), the diaphragm (28), and the gasket (29), then remove them from the pump (**Figure 14-16, Page 14-22**).

⚠ CAUTION

- Fuel pump gaskets and diaphragms must be reinstalled in exactly the same positions and orientations they were in before disassembly, or the pump could leak. If leaking occurs, all new gaskets and diaphragms must be installed.

4. If the impulse gasket (27) and the diaphragm (28) come off with the front cover, note their orientations and remove them (**Figure 14-16, Page 14-22**).
5. Remove the pumping chamber (30) (**Figure 14-16, Page 14-22**).
6. Remove the back cover (36), the fuel diaphragm (34) and gasket (35) (**Figure 14-16, Page 14-22**).

FUEL PUMP CLEANING AND INSPECTION

1. Using a nonflammable solvent, clean the front cover, pumping chamber, and back cover. Be sure the vent on the front cover is clean both inside and out.
2. Inspect the valve assemblies (31, 32, and 33) and all gaskets and diaphragms for damage (**Figure 14-16, Page 14-22**).
3. If a valve assembly is damaged, the rubber retaining plug (33) and valve assembly must be replaced (**Figure 14-16, Page 14-22**).

FUEL PUMP ASSEMBLY

1. Install the fuel gasket (35) and diaphragm (34) on the back cover (36) (**Figure 14-16, Page 14-22**).
2. Install the valve assembly in the pumping chamber (30) (**Figure 14-16, Page 14-22**). See following **CAUTION**.

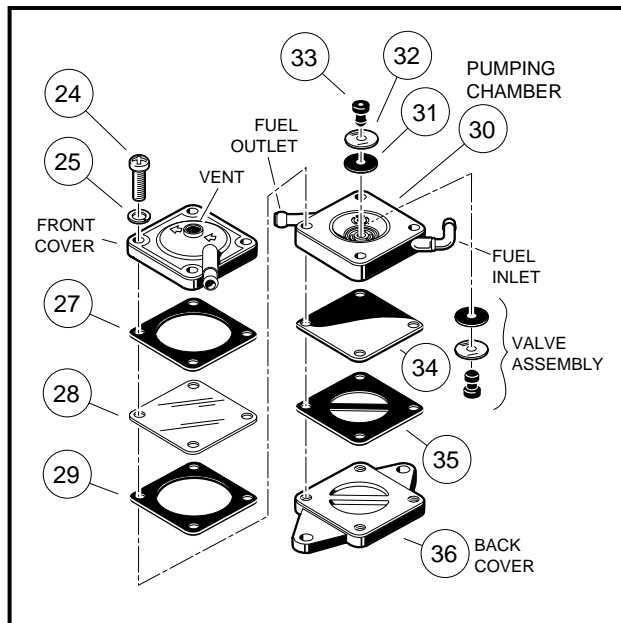

Figure 14-16 Fuel Pump

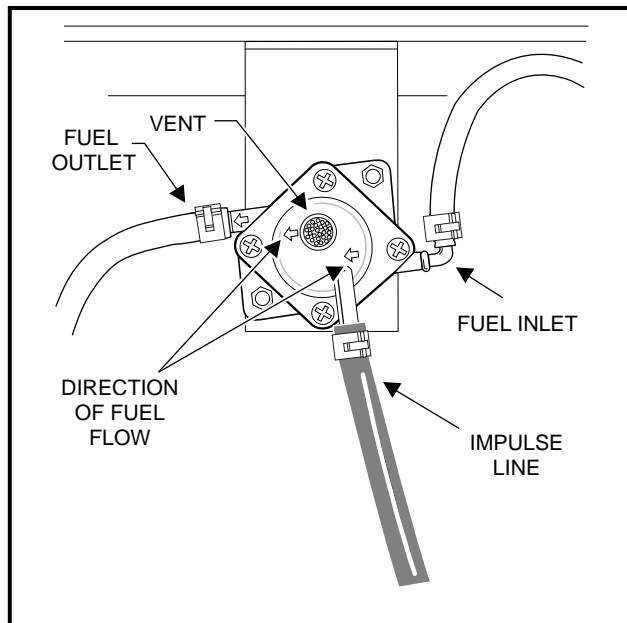

Figure 14-17 Fuel Pump Orientation

⚠ CAUTION

- If the valve assembly is not installed exactly as shown, the impulse fuel pump will not operate properly.

3. Install the pumping chamber (30) on top of the fuel diaphragm (34). Be sure the fuel inlet and the fuel outlet align with the arrows on the front of the front cover (**Figure 14-16, Page 14-22**).
4. Install the gasket (29), clear impulse diaphragm (28), and the paper impulse gasket (27) to the pumping chamber (30) (**Figure 14-16, Page 14-22**).
5. Install the front cover and then the lock washers (25) and four screws (24) on the assembly (**Figure 14-16, Page 14-22**). Be sure the arrows on the front cover point from the fuel inlet to the fuel outlet (**Figure 14-17, Page 14-22**). Tighten the screws to 26 in-lb (3.0 N·m).

FUEL PUMP INSTALLATION

1. Connect to the fuel pump the fuel line (2) that comes from the fuel filter (17). Install a new clamp (16) (**Figure 14-15, Page 14-20**). **See same figure for proper routing of fuel lines.**

NOTE: Be sure to connect the fuel line (2), that comes from the primary fuel filter (17), to the inlet nipple on the pump. Direction of fuel flow is indicated by the arrows on the fuel pump (**Figure 14-15, Page 14-20**). **See also Figure 14-17, Page 14-22.**

2. Connect to the output side of the fuel pump, the fuel line (3) that goes to the secondary fuel filter (22) (**Figure 14-15, Page 14-20**).
3. Connect the impulse line (7) to the bottom nipple on the fuel pump. Use a new clamp (20) (**Figure 14-15, Page 14-20**).
4. Install the fuel pump onto the mounting bracket with two thread-rolling screws (25) and tighten to 40 in-lb (4.5 N·m) (**Figure 14-15, Page 14-20**).
5. Turn the fuel shut-off valve on top of the gas tank to the open position (**Figure 14-22, Page 14-28 and Figure 14-23, Page 14-28**).
6. Place the Forward/Reverse handle in the NEUTRAL position and chock the wheels. Start the engine and check for fuel leaks. If the fuel pump leaks, a rebuild kit must be installed to replace all gaskets and diaphragms. **See following DANGER.**

▲ DANGER

- *Repair any fuel leaks before using the vehicle.*

FUEL TANK

Read **DANGER** and **WARNING** on page 14-1.

▲ WARNING

- If the fuel tank is damaged, replace it. Do not attempt to repair it. See the following tank removal and disposal procedure.

▲ CAUTION

- *Add only unleaded gasoline to the tank. Do not put oil into the fuel tank.*

GENERAL INFORMATION

The vehicle is equipped with a high impact plastic, seven gallon (26.5 liter) fuel tank.

PREPARATION FOR EXTENDED STORAGE

See **Storage – Gasoline Vehicle, Section 3, Page 3-1.**

FUEL TANK REMOVAL

1. Chock the wheels and release the park brake.
2. Access the engine compartment. **See DANGER on page 14-1.**
 - 2.1. Tilt the bed and ensure that the prop rod is engaged.
3. Completely remove both seats from the vehicle and lift bed to access engine compartment.
4. Place the Forward/Reverse handle in the NEUTRAL position.
5. Turn fuel shut-off valve to the closed (OFF) position (**Figure 14-21, Page 14-28**) and run the engine until fuel remaining in the carburetor, fuel pump, and fuel lines is used up and the engine stalls.
6. Remove the four bolts (8), eight washers (9) and four lock nuts (10) from the seat support. **See Figure 4-2, Section 4, Page 4-7.**
7. Remove the two armrests (11 and 12) from the vehicle **See Figure 4-2, Section 4, Page 4-7.**
8. Carefully remove and rotate the seat support (7) 90° clockwise and allow it to rest on the vehicle body as illustrated (**Figure 14-18, Page 14-24**). **See following NOTE.**

NOTE: It is not necessary to remove the park brake cable or differential lock cable to service or remove the fuel tank.

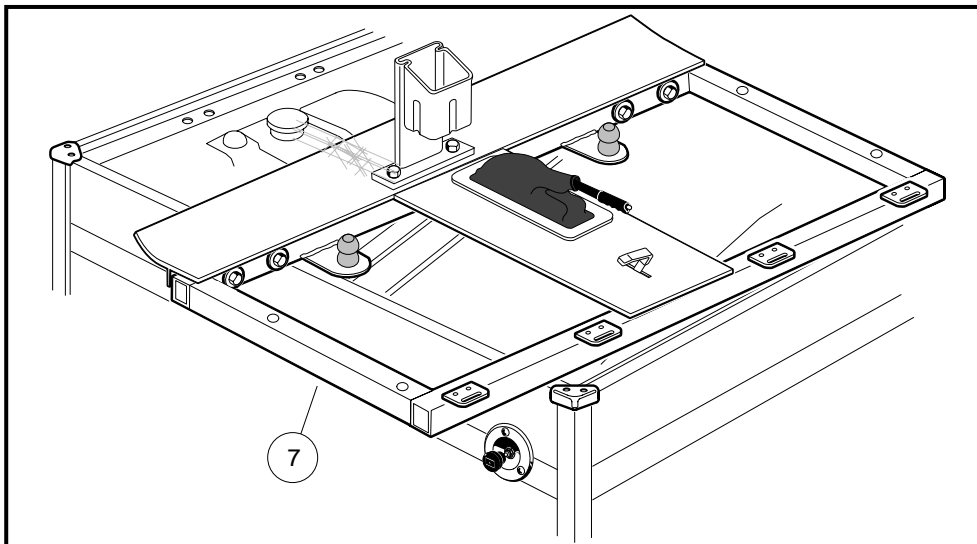

Figure 14-18 Fuel Tank Removal

9. Loosen (do not remove) the carburetor drain screw (11) (**Figure 14-7, Page 14-7**) and drain fuel remaining in the carburetor bowl into an approved container.
10. Using a siphon with a suction device, siphon all fuel out of the tank and into an approved container. **See following DANGER and WARNING.**

▲ DANGER

- **Gasoline! Flammable! Explosive! Do not smoke. Keep sparks and flames away from the vehicle and service area.**

▲ WARNING

- **Never attempt to siphon fuel using a hose that does not have a built-in suction device.**
 - **Never attempt to siphon fuel using your mouth.**
11. Disconnect the black wire and orange wire from the fuel level sending unit on the tank (**Figure 14-19, Page 14-26**). Do NOT remove the lower nut on the center stud of the sending unit. **See following WARNING.**

▲ WARNING

- **Make sure the key switch is OFF before disconnecting wiring.**
12. Remove the vent tube (6) and fuel line (1) from the fuel tank (**Figure 14-15, Page 14-20**).
 13. Loosen the straps (13) and (10) by removing the screws (12 and 14) from the speed nuts (11) (**Figure 14-15, Page 14-20**).
 14. Lift the fuel tank out of the vehicle.

FUEL TANK DISPOSAL

1. Remove the cap from the tank and thoroughly rinse it with water. The cap may be discarded or kept as a spare.
2. In a well-ventilated area, flush the fuel tank with water to remove any remaining gasoline.
3. In a well-ventilated area, set the tank upside down so that the water can drain out of it. To make sure that the tank dries completely, allow the tank to sit for 24 hours. **See following CAUTION.**

▲ CAUTION

- *Dispose of wastewater and fuel tank in accordance with federal, state and local laws and ordinances.*

FUEL TANK STORAGE

1. Remove the cap from the tank and thoroughly rinse it with water.
2. In a well-ventilated area, flush the fuel tank with water to remove any remaining gasoline.
3. In a well-ventilated area, set the tank upside down so that the water can drain out of it. To make sure that the tank dries completely, allow the tank to sit for 24 hours.
4. Store the tank upside down, with the cap installed, in a well-ventilated area.

FUEL TANK INSTALLATION

1. With the retaining straps correctly positioned, install the fuel tank in the vehicle.
2. Secure the tank with the retaining straps (13) and (10) (**Figure 14-15, Page 14-20**).
 - 2.1. Position the straps in the indentions on the tank.
 - 2.2. Install the screws (12 and 14) into the speed nuts (11). Tighten screws to 25 in-lb (2.8 N·m) (**Figure 14-15, Page 14-20**).

- Return the seat support (1) to its original position by rotating it 90° counterclockwise (**Figure 14-18, Page 14-24**) and install the seat support and armrests. Tighten bolts (8) to 13 ft-lb (17.6 N·m) **See Figure 4-2, Section 4, Page 4-7.**

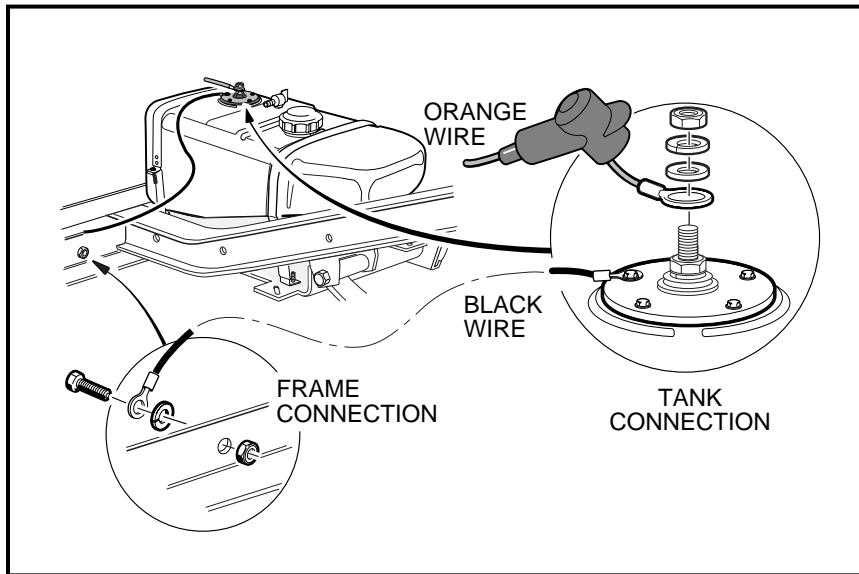

Figure 14-19 Fuel Level Sending Unit

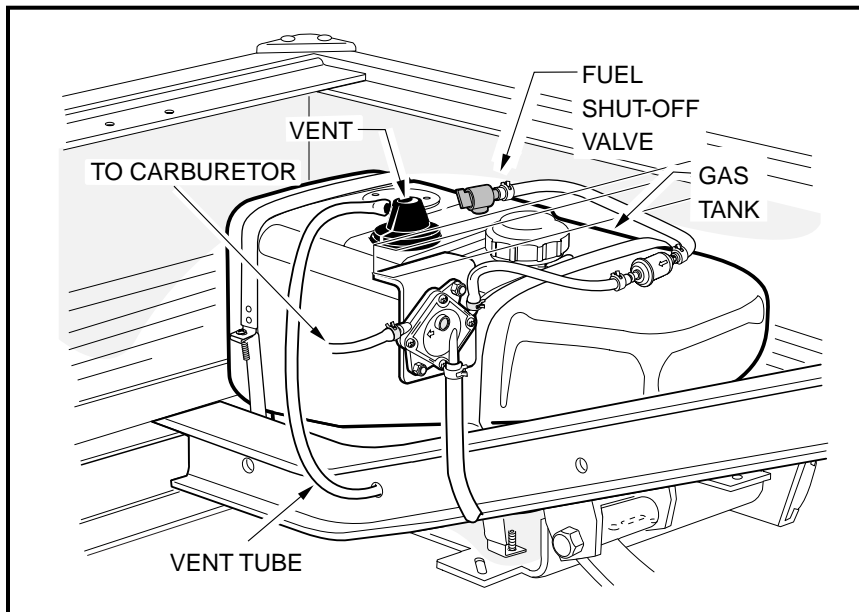

Figure 14-20 Fuel Tank

- Connect the vent tube (6) to the gas tank vent (**Figure 14-15, Page 14-20**).
- Connect the fuel line (1) to the fuel tank shut-off valve (15). Use a new clamp (**Figure 14-15, Page 14-20**).
- Connect the black wire from the fuel gauge to one of the fuel level sending unit screws. Connect the orange wire to the center stud (**Figure 14-19, Page 14-26**) and install the flat washer, lock washer and nut. Tighten to 18 in-lb (2.0 N·m).
- Slide the rubber boot over the stud (**Figure 14-19, Page 14-26**).

8. Check the park brake and differential lock lever for proper adjustment and operation.
9. Add gasoline to the tank.
10. Reconnect the battery, positive (+) cable first. Tighten terminals to 20 ft-lb (27.1 N·m).
11. Ensure that the wheels are chocked and the Forward/Reverse handle is in the NEUTRAL position.
12. Check to be sure the fuel shut-off valve on top of the gas tank is in the open (ON) position (**Figure 14-22, Page 14-28**) and (**Figure 14-23, Page 14-28**).
13. Start the engine and allow it to idle. **See the following DANGER.**

▲ DANGER

- *The engine produces carbon monoxide, which is an odorless, deadly poison. Do not operate the engine in an enclosed area without proper ventilation.*
- *After installing the fuel tank and adding gasoline, carefully check all fuel lines and connections for leaks. Repair any leaks before using the vehicle.*

14. Allow the engine to run for a few minutes to ensure that the fuel lines are full of fuel.
15. Inspect each fuel line for leaks.
 - 15.1. Check all of the fuel line clamps at the carburetor, fuel filters, fuel pump, and fuel tank for leaks.
 - 15.2. Inspect each fuel line to ensure that the lines are not cracked, cut, or worn.

FUEL LINES

Read DANGER and WARNING on page 14-1.

The fuel lines must be properly routed, and all hose clamps must be tight. The fuel lines should be kept clean. **See following WARNING.**

▲ WARNING

- **Make sure fuel lines are the right length and are properly routed. Failure to heed this warning could result in damage to fuel lines and fire.**

Fuel line No. 1 runs directly from the fuel tank to the fuel filter (17). The primary fuel filter (17) has an arrow indicating fuel flow direction (**Figure 14-15, Page 14-20**).

Fuel line No. 2 runs directly from the fuel filter to the fuel inlet of the fuel pump.

Fuel line No. 3 runs directly from the fuel outlet of the fuel pump to the secondary fuel filter (**Figure 14-15, Page 14-20**). The secondary fuel filter has an arrow indicating fuel flow direction and is identical to the primary fuel filter.

Fuel line No. 4 runs from the outlet of the secondary fuel filter to the carburetor (**Figure 14-15, Page 14-20**).

Small spring steel band clamps are used on all hose connections except at the carburetor. A screw band clamp should be used at the carburetor (**Figure 14-15, Page 14-20**).

FUEL SHUT-OFF VALVE

Read **DANGER** and **WARNING** on page 14-1.

The fuel shut-off valve is located on top of the fuel tank (**Figure 14-20, Page 14-26**). The fuel shut-off valve should always be turned to the closed (OFF) position during vehicle storage, towing or trailering (**Figure 14-21, Page 14-28**). Unless the engine will be run as part of a procedure, the fuel shut-off valve should also be closed (OFF) before performing maintenance or service procedures.

Fully Open Position

The valve's open position differs from standard valve configurations. For the valve to be fully open, it must be turned approximately 120° from the closed (OFF) position (until it cannot be turned any further) (**Figure 14-22, Page 14-28**). If the valve becomes partially closed (**Figure 14-23, Page 14-28**), the engine will not run properly due to fuel starvation.

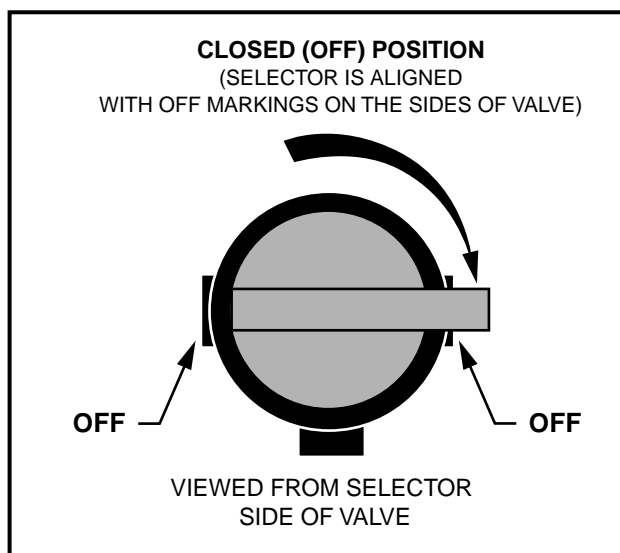

Figure 14-21 Closed Fuel Shut-off Valve

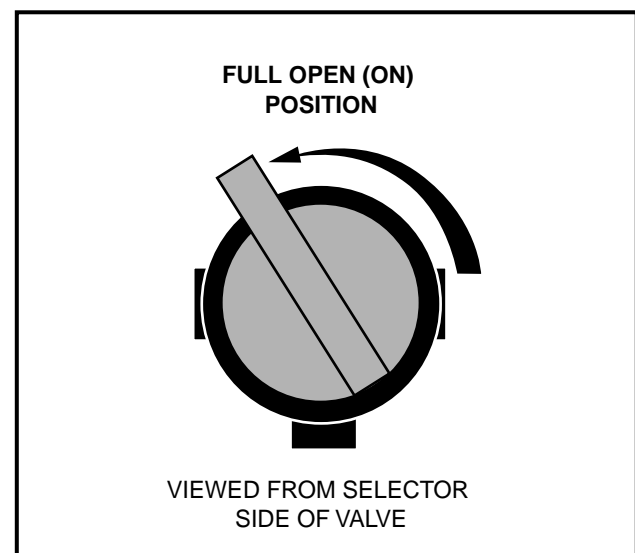

Figure 14-22 Open Fuel Shut-off Valve

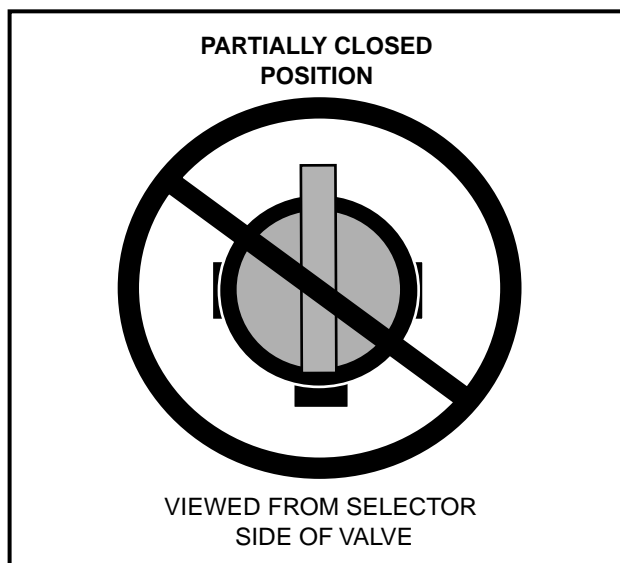

Figure 14-23 Incorrect Fuel Shut-off Valve

SECTION 15 – EXHAUST SYSTEM

⚠ DANGER

- *Gasoline – Flammable! Explosive! Do not smoke. Keep sparks and flames away from vehicle and service area. Service only in a well-ventilated area.*
- *Do not operate gasoline vehicle in an enclosed area without proper ventilation. The engine produces carbon monoxide, which is an odorless, deadly poison.*

⚠ WARNING

- Only trained technicians should repair or service this vehicle. Anyone doing even simple repairs or service should have knowledge and experience in electrical and mechanical repair.
- Follow the procedures exactly as stated in this manual, and heed all DANGER, WARNING, and CAUTION statements in this manual as well as those affixed to the vehicle.
- Wear safety glasses or approved eye protection while servicing vehicle. Wear a full face shield and rubber gloves when working with batteries.
- Turn key switch OFF, place Forward/Reverse handle in the NEUTRAL position, and remove key prior to servicing.
- Moving parts! Do not attempt to service the vehicle while it is running.
- Do not wear loose clothing. Remove jewelry such as rings, watches, chains, etc. before servicing vehicle.
- Hot! Do not attempt to service hot engine or exhaust system. Failure to heed this warning could result in severe burns.
- Use insulated tools when working near batteries or electrical connections. Use extreme caution to avoid shorting of components or wiring.
- Frame ground – Do not allow tools or other metal objects to contact frame when disconnecting battery cables or other electric wiring. Never allow a positive wire to touch the vehicle frame, engine or any other metal component.
- To avoid unintentionally starting the vehicle:
 - Disconnect battery cables, negative cable (–) first.
 - Disconnect the spark plug wire from the spark plug.
- The prop rod on the vehicle should be securely engaged prior to servicing. Remove all cargo before raising the bed. Do not disengage prop rod until all persons are clear of cargo bed area. Do not drop cargo bed; lower gently and keep entire body clear. Failure to follow these instructions could result in severe injury.

GENERAL INFORMATION

The exhaust system is designed to provide quiet vehicle operation. If the muffler should ever need to be removed for repairs or replacement, follow the instructions below.

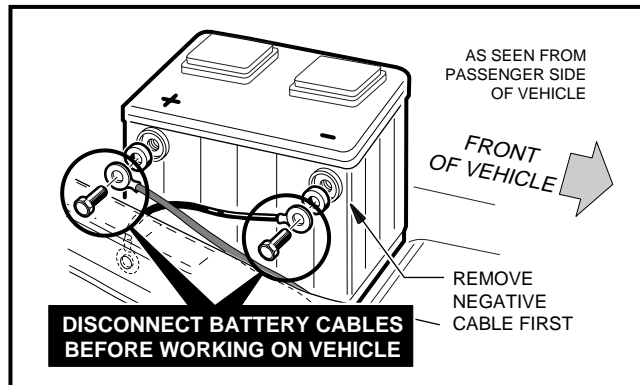

Figure 15-1 FE350 Battery

MUFFLER

Read **DANGER** and **WARNING** on page 15-1.

MUFFLER REMOVAL

1. Disconnect the battery cables, negative (–) cable first (**Figure 15-1, Page 15-2**).
2. Disconnect the spark plug wire from the spark plug.
3. Remove the hex nuts (10) and lock washers (11) (**Figure 15-2, Page 15-3**).
4. Remove the hex head cap screw (7), lock washer (8), and flat washer (9).
5. Remove the retaining bolts (5), lock washers (4), and flat washers (3) from the muffler bracket (2).
6. Remove the muffler (1) and bracket assembly (2) from the vehicle.
7. Remove the muffler clamp (6) from the muffler bracket (2).

MUFFLER INSTALLATION

NOTE: Any time the muffler is removed from the vehicle, install a new muffler clamp (6) (CCI 1017689) and muffler gasket (**Figure 15-2, Page 15-3**).

1. Use the muffler clamp (6) to attach the muffler bracket (2) to the muffler as shown (**Figure 15-2, Page 15-3**). Leave the muffler clamp loose enough to allow the muffler to move as the mounting hardware is tightened. If installing a new muffler, use the old muffler as a positioning guide for the clamp and bracket.
2. Place a new gasket (12) on the exhaust manifold mounting flange as shown.
3. Position the muffler and bracket assembly, and the governor cable bracket (13) and install the bolts (5), lock washers (4), and flat washers (3). Thread the bolts in only enough to support the muffler and bracket assembly. Do not tighten them.
4. Install the hex nuts (10) and lock washers (11). Tighten the nuts fingertight.
5. Install the hex head cap screw (7), lock washer (8), and flat washer (9). Tighten the cap screw fingertight.

6. Tighten the hex nuts (10) to 11 ft-lb (14.9 N·m).
7. Tighten the hex cap screw (7) to 14 ft-lb (18.9 N·m).
8. Tighten the muffler clamp (6) to 40 in-lb (4.5 N·m).
9. Tighten the muffler bracket mounting bolts (5) to 75 in-lb (8.5 N·m).
10. Reconnect the spark plug wire.
11. Connect battery cables, positive (+) first and tighten terminals to 20 ft-lb (27.1 N·m) (**Figure 15-1, Page 15-2**). Coat terminals with Battery Protector Spray (CCI 1014305).
12. Place the Forward/Reverse handle in the NEUTRAL position and chock the wheels. Start the engine and check for exhaust leaks and proper engine operation. **See following DANGER.**

▲ DANGER

- *The engine produces carbon monoxide, which is an odorless, deadly poison. Do not operate the engine in an enclosed area without proper ventilation.*

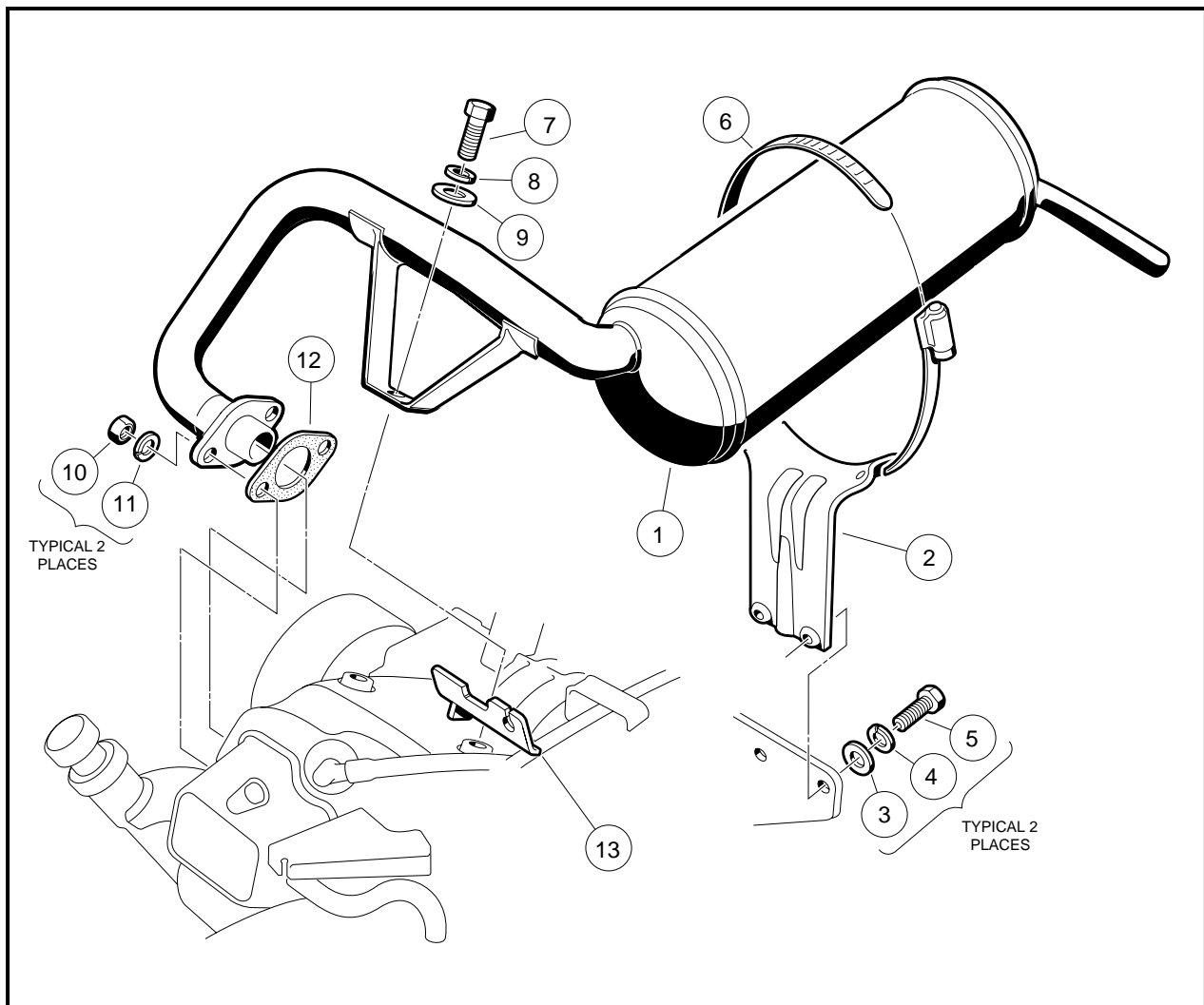

Figure 15-2 Exhaust System

SECTION 16 – UNITIZED TRANSAXLE WITH DIFFERENTIAL LOCK

⚠ DANGER

- *Gasoline – Flammable! Explosive! Do not smoke. Keep sparks and flames away from vehicle and service area. Service only in a well-ventilated area.*
- *Do not operate gasoline vehicle in an enclosed area without proper ventilation. The engine produces carbon monoxide, which is an odorless, deadly poison.*

⚠ WARNING

- Only trained technicians should repair or service this vehicle. Anyone doing even simple repairs or service should have knowledge and experience in electrical and mechanical repair.
- Follow the procedures exactly as stated in this manual, and heed all DANGER, WARNING, and CAUTION statements in this manual as well as those affixed to the vehicle.
- Wear safety glasses or approved eye protection while servicing vehicle. Wear a full face shield and rubber gloves when working with batteries.
- Turn key switch OFF, place Forward/Reverse handle in the NEUTRAL position, and remove key before servicing the vehicle.
- Hot! Do not attempt to service hot engine or exhaust system. Failure to heed this warning could result in severe burns.
- Moving parts! Do not attempt to service the vehicle while it is running.
- Use insulated tools when working near batteries or electrical connections. Use extreme caution to avoid shorting of components or wiring.
- Frame ground – Do not allow tools or other metal objects to contact frame when disconnecting battery cables or other electrical wiring. Never allow a positive wire to touch the vehicle frame, engine, or any other metal component.
- To avoid unintentionally starting the vehicle:
 - Disconnect battery cables, negative cable (–) first.
 - Disconnect the spark plug wire from the spark plug.
- Lift only one end of the vehicle at a time. Before lifting, set the park brake when lifting the front of the vehicle, unload the cargo bed, and chock the wheels that remain on the floor. Use a suitable lifting device (chain hoist or hydraulic floor jack) with 1000 lb. (454 kg) minimum lifting capacity. Do not use lifting device to hold vehicle in raised position. Use approved jack stands of proper weight capacity to support the vehicle.

GENERAL INFORMATION

The Pioneer 1200 gasoline-powered vehicle is equipped with a heavy-duty, fully-synchronized Unitized Transaxle with Differential Lock. The unitized transaxle utilizes fully-synchronized internal gearing to change vehicle direction. Because the unitized transaxle is used to reverse vehicle direction, the engine, drive clutch, belt, and driven clutch rotate in the same direction; therefore, the engine and clutches are not subjected to reversing loads. This reduces maintenance requirements on the engine and clutches. With the unitized transaxle, power is transferred from the engine through the drive clutch, the drive belt, the driven clutch, and then through the unitized transaxle to the wheels.

Shifter Lever

A shifter lever, connected to a shifter arm on the unitized transaxle, is used to change the gears to one of three shift positions: FORWARD (F), NEUTRAL (N), or REVERSE (R) (**Figure 16-1, Page 16-2**). The vehicle should come to a complete stop before changing FORWARD or REVERSE direction.

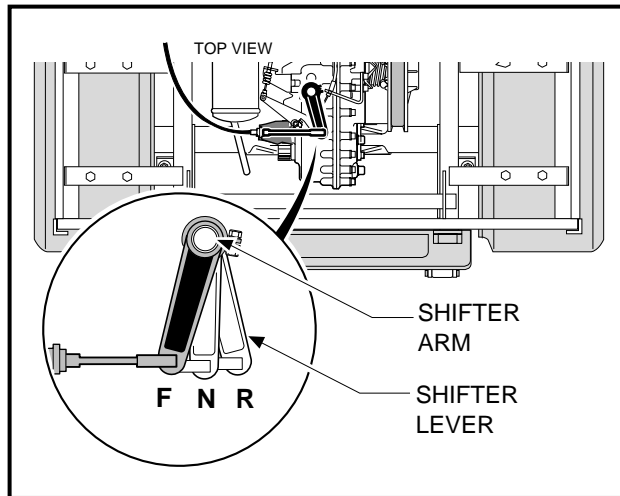

Figure 16-1 Shifter Positions

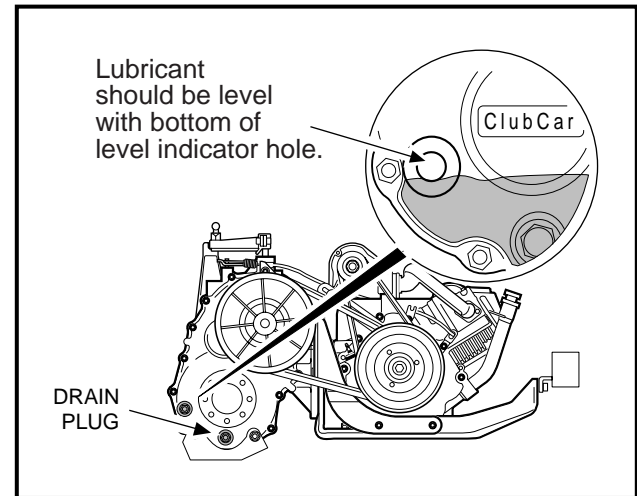

Figure 16-2 Lubricant Level

Differential Lock Lever

The Pioneer 1200 unitized transaxle has a differential lock, controlled by a differential lock lever. The lever is located between the driver and passenger seats (**Figure 16-3, Page 16-2**).



Figure 16-3 Differential Lock Lever

Lockout Cam

The Pioneer 1200 vehicle has a lockout circuit that prevents a driver from starting the vehicle when it is in gear. The engine can be started only when the Forward/Reverse handle is in the NEUTRAL position. **See Lockout Cam Circuit, Section 11, Page 11-12.**

Governor System

The governor system is a flyweight type, and regulates vehicle ground speed. It is mounted inside the unitized transaxle and is driven by transaxle gears. Because the governor is mounted inside the transaxle, it is protected from abuse and damage common to externally mounted governor systems. If any of the governor linkages are removed in order to service other components, readjustment of the governor linkage is required. **See Governor Cable Installation and Adjustment, Section 14, Page 14-10.**

Unitized Transaxle Service

The unitized transaxle is extremely durable and should require very little service under normal operating conditions. The only maintenance required on the unitized transaxle is to maintain proper lubricant level. **See Periodic Lubrication Schedule, Section 10, Page 10-4.** Under normal operating conditions, adjustment to the system should not be required.

Tools Required For This Section

Hydraulic floor jack (or chain hoist)	12 to 18 in. straight edge	17 mm socket, 3/8 in. drive
Jack stands (2) (one ton capacity)	Small ball peen hammer (10 oz.)	7/16 combination wrench
Hydraulic press	Plastic or rubber mallet	1/2 combination wrench
Bench vise	Ratchet wrench, 3/8 drive	9/16 combination wrench
Standard slip joint pliers	Torque wrench, 3/8 drive	11/16 combination wrench (2)
External snap ring pliers (.070 in. tip)	3/8 socket, 3/8 in. drive	17 mm combination wrench
External snap ring pliers (.047 in. tip)	7/16 socket, 3/8 in. drive	Small flat blade screwdriver
90° internal snap ring pliers (.090 in. tip)	10 mm combination wrench	Medium flat blade screwdrivers (2)
Feeler gauge	1/2 socket, 3/8 drive	No. 2 phillips head screwdriver
16 in. rolling head prybar	9/16 socket, 3/8 drive	1/4 nut driver
Small punch or scratch awl	5/8 in. socket, 3/8 drive	5/16 nut driver
1/4 in. diameter drift or metal rod	12 mm socket, 3/8 drive	Small knife or wire snippers
Bearing puller wedge attachment (CCI 1012812)	Axle seal tool (CCI 1014162)	Governor gear shaft installation tool (CCI 101933101)
3/8 in. flare nut wrench	1/4 in. combination wrench	

LUBRICATION

There are two plugs located on the right (driven clutch) side of the unitized transaxle (**Figure 16-2, Page 16-2**). When the vehicle is on a level surface, the upper plug is used as a lubricant level indicator. Lubricant level should be even with the bottom of level indicator hole. The lower plug is used for draining lubricant from the transaxle. When draining lubricant, both plugs should be removed to allow the lubricant to drain faster. Be sure the drain plug and gasket are cleaned and reinstalled before filling the transaxle with new lubricant. Tighten the plug to 20 ft-lb (27.1 N-m). Use a funnel when filling the transaxle through the lubricant level indicator hole. Fill with 31 oz. (.92 liters) 80-90 Wt. API class GL-3 or 80-90 Wt. AGMA class 5 EP gear lubricant (or until lubricant begins to run out of the level indicator hole).

AXLE SHAFT

Read DANGER and WARNING on page 16-1.

Removal of the unitized transaxle is not required for servicing or replacing axle shafts, axle bearings, or axle shaft oil seals. If the unitized transaxle is to be removed from the vehicle, then **do not** remove the wheels, axle shafts, or axle tubes first. Instructions for removing the unitized transaxle from the vehicle begin on page 16-7.

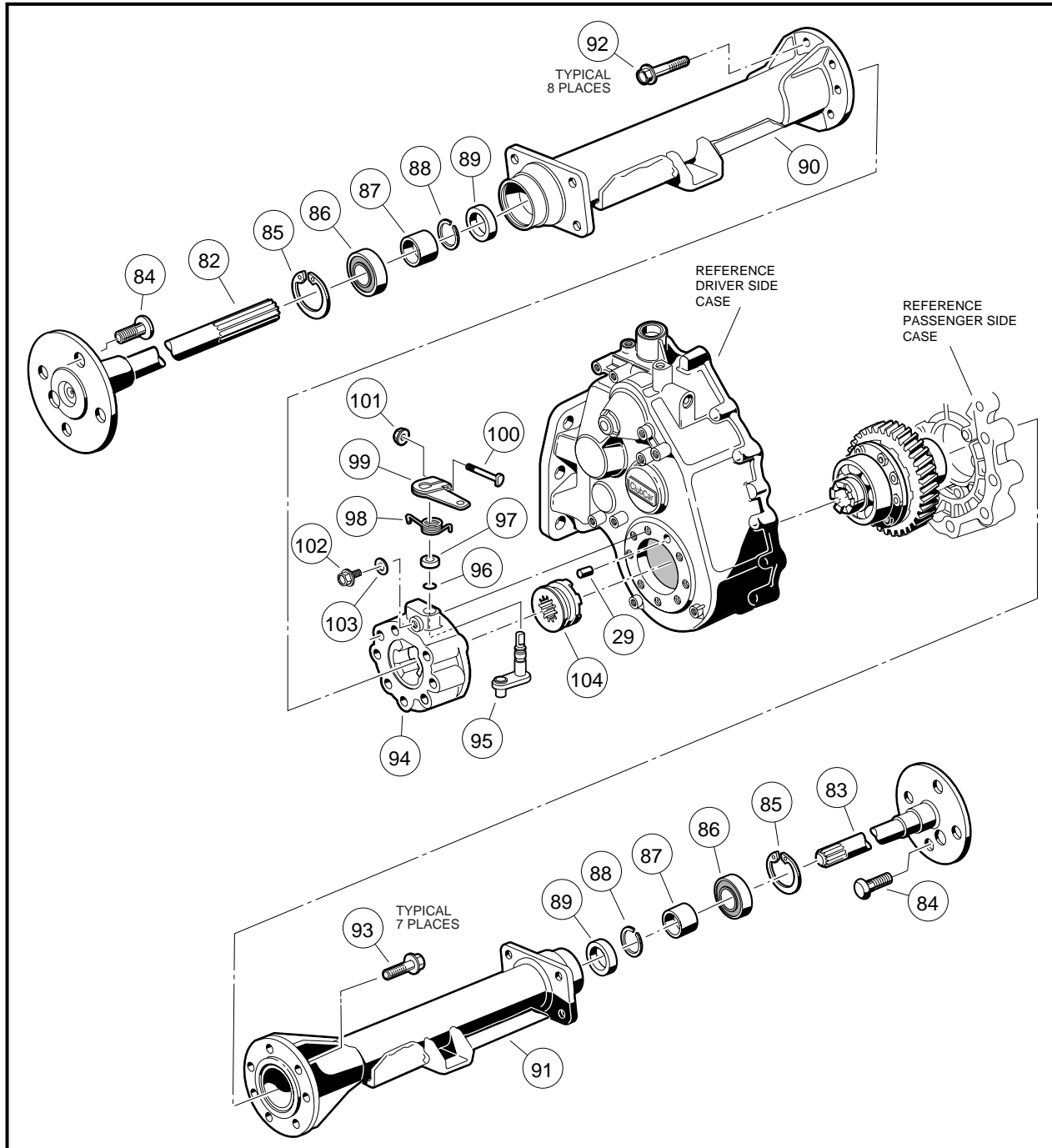

Figure 16-4 Differential Gear Case/Axle Tubes

AXLE SHAFT AND OIL SEAL REMOVAL

1. Loosen the lug nuts on the wheel to be removed.
2. Place chocks at the front wheels and lift the rear of the vehicle with a floor jack. Then place jack stands under the axle tubes to support the vehicle. **See WARNING on page 16-1.**
3. Remove the rear wheel and brake drum.
4. Using 90° internal snap ring pliers (.090 tip), remove internal retaining ring from axle tube (**Figure 16-5, Page 16-5**).

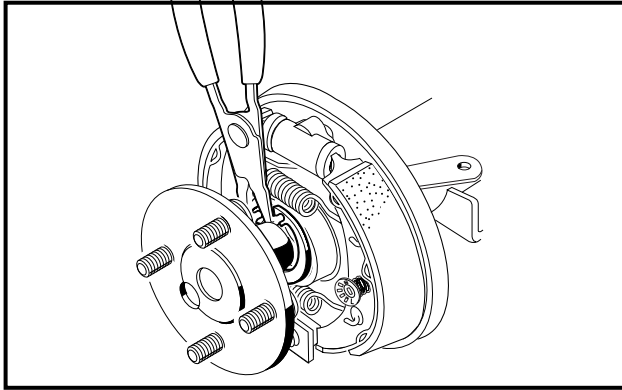

Figure 16-5 Retaining Ring

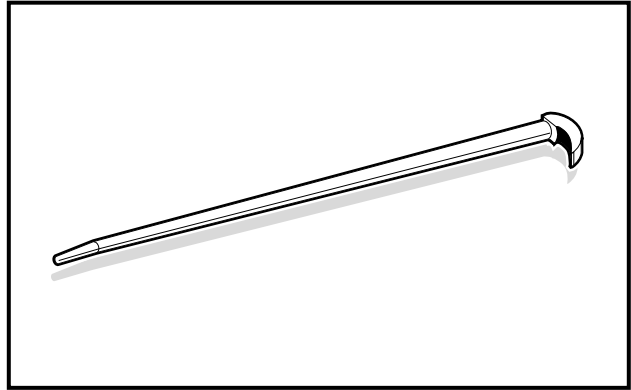

Figure 16-6 Rolling Head Prybar

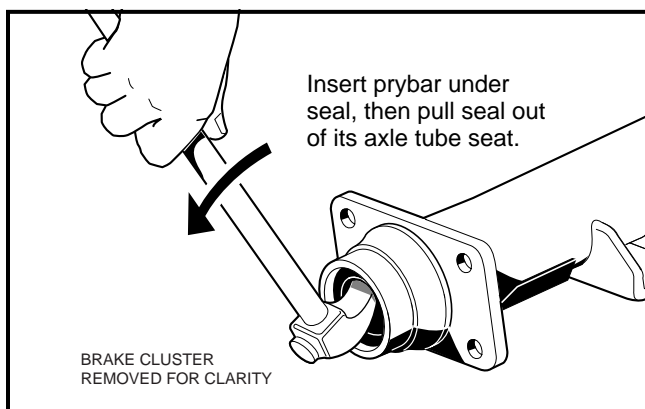

Figure 16-7 Seal Lip

5. Carefully pull the axle shaft straight out of the axle tube.
6. Use a 16 inch (40 cm) rolling head prybar (**Figure 16-6, Page 16-5**) to remove the oil seal. Insert the prybar under the seal and pull oil seal out (**Figure 16-7, Page 16-5**). **See following CAUTION.**

⚠ CAUTION

- Do not scar or damage the inside surfaces of the tube when removing the oil seal. A damaged tube might have to be replaced.
7. Inspect the axle shaft assembly to be sure the bearing (86) and collar (87) have not slipped and are still seated against the shoulder on the axle shaft (**Figure 16-4, Page 16-4**).
 8. Inspect the bearing. If the bearing is damaged or worn, replace it.

AXLE BEARING

Axle Bearing Removal

1. Use external retaining ring pliers (.047 tip) to remove the retaining ring (88) (**Figure 16-4, Page 16-4**), then place a bearing puller wedge attachment (CCI 1012812) on the axle shaft between the wheel mounting flange and the bearing. **See following CAUTION.**

⚠ CAUTION

- Do not tighten the bearing puller wedge attachment against the axle shaft. This could damage the axle shaft when pressing the bearing and collar off.

Axle Bearing Removal, Continued:

2. Press the bearing (86) and collar (87) off together (**Figure 16-4, Page 16-4**). Leave the retaining ring (85) on the axle shaft. **See also Figure 16-8, Page 16-6. See following NOTE.**

NOTE: It may be necessary to heat the collar to remove it.

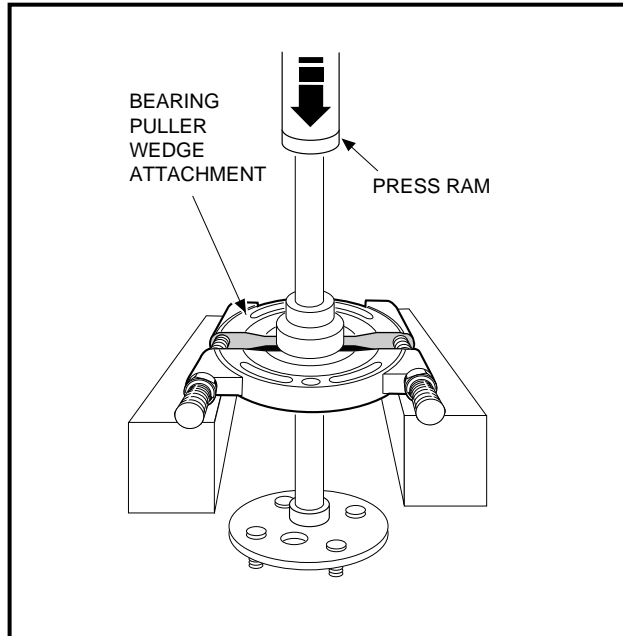

Figure 16-8 Bearing and Collar

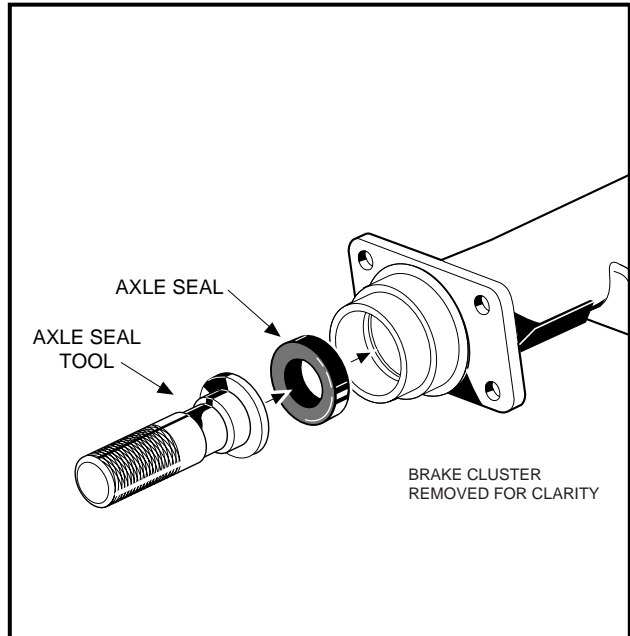

Figure 16-9 Axle Seal Tool

Axle Bearing Installation

1. Install axle bearing (86) on axle (82 or 83). Push bearing onto axle until bearing is flush against axle shoulder (**Figure 16-4, Page 16-4**).
2. Apply two drops of Loctite 271[®] to inside of the collar. **See following CAUTION.**

⚠ CAUTION

- Apply Loctite 271 to the inside of the collar only, not to the shaft, so that the Loctite will be pushed away from the bearing as the collar and bearing are pressed on. If Loctite gets on or in the bearing, the bearing must be replaced.
 - The collar should be removed no more than two times. If a collar is removed a third time, the shaft and collar will not fit properly.
3. Install collar (87) (**Figure 16-4, Page 16-4**) onto axle shaft. Place axle assembly on bearing puller wedge attachment and press collar onto axle.
 4. Use external snap ring pliers (0.047 tip) to install the retaining ring (88) (**Figure 16-4, Page 16-4**).
 5. Place a **new** (sealed) bearing (86) and collar (87) on shaft (82 or 83) (**Figure 16-4, Page 16-4**).
 6. Place the bearing puller wedge attachment against collar and press both bearing and collar onto shaft. Install the retaining ring (88) (**Figure 16-4, Page 16-4**). **See following CAUTION.**

▲ CAUTION

- If the bearing was removed from the shaft, replace it with a new one.
- Do not tighten the bearing puller wedge attachment against the axle shaft. This could damage the axle shaft when the bearing and collar are pressed on.

AXLE SHAFT INSTALLATION

1. Clean bearing and seal seats in axle tube (90 or 91) (**Figure 16-4, Page 16-4**).
2. Place a new seal (89) (**Figure 16-4, Page 16-4**) in axle tube with seal lip facing inside of the axle tube. Use an axle seal tool (CCI 1014162) to press it in until it seats firmly in position (**Figure 16-9, Page 16-6**). See following **NOTE**.

NOTE: The new seal can be installed by tapping the axle seal tool with a mallet.

3. Clean the axle shaft and splines and then insert the shaft, splined end first, through the seal and into the axle tube. Be careful not to damage the seal. Then advance the shaft through the inner bearing and rotate it to align the shaft splines with the splined bore of the differential side gear. Continue advancing the shaft until the bearing seats against the axle tube shoulder.
4. Install retaining ring (85) (**Figure 16-4, Page 16-4**) in the axle tube. See also **Figure 16-5, Page 16-5**.
5. Place a 1/4 to 3/8 inch (6-10 mm) diameter rod against the retaining ring and tap lightly at four to five locations to ensure it is properly seated. See following **WARNING**.

▲ WARNING

- Be sure retaining ring is properly seated in its groove. If ring is not properly installed, the axle assembly will separate from the transaxle and damage the axle assembly and other components. Loss of vehicle control could result in severe personal injury or death.

UNITIZED TRANSAXLE REMOVAL

Read **DANGER** and **WARNING** on page 16-1.

▲ WARNING

- To perform this procedure, the hydraulic system must be opened. As a result, the brakes must be bled after the correct reinstallation of the brake components. Failure to bleed the brakes could result in decreased braking performance due to air being trapped in the hydraulic system. Use only DOT 5 brake fluid. See **Bleeding the Hydraulic Brake System, Section 6, Page 6-29**.
1. Disconnect the battery cables, negative cable (–) first.
 2. Close the fuel shut-off valve on fuel tank. See **Figure 14-21, Section 14, Page 14-28**.
 3. Detach all wires, hoses, etc. connecting the powertrain to the vehicle.
 - 3.1. Disconnect the carburetor vent tube from the carburetor (**Figure 16-10, Page 16-8**).
 - 3.2. Disconnect the air intake hose from the carburetor (**Figure 16-11, Page 16-8**).
 - 3.3. Disconnect impulse line from fuel pump (**Figure 16-12, Page 16-8**).
 - 3.4. Loosen the hose clamp and then disconnect the fuel line from the carburetor. To prevent spilling fuel, the disconnected end of the line can be pushed onto the impulse line fitting of the fuel pump (**Figure 16-15, Page 16-9**).

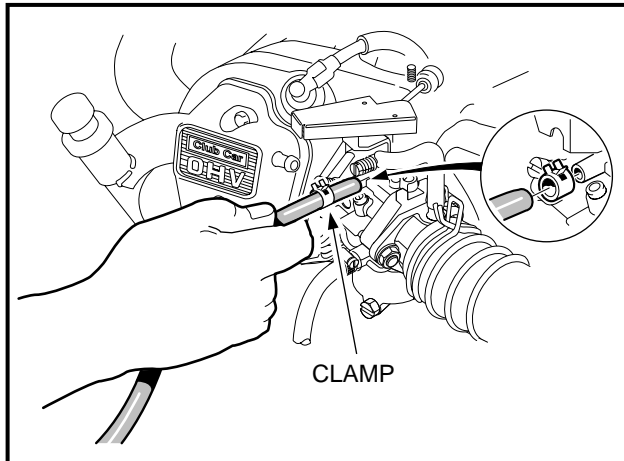

Figure 16-10 Carburetor Vent Tube

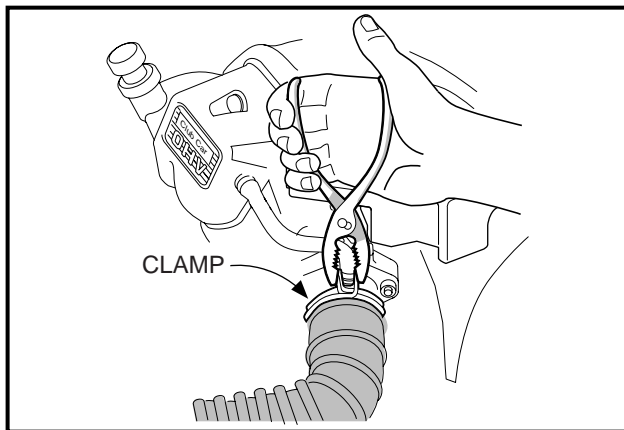

Figure 16-11 Air Intake Hose

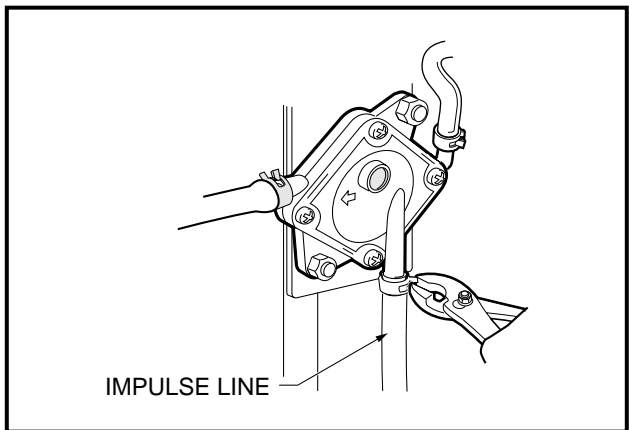

Figure 16-12 Impulse Line

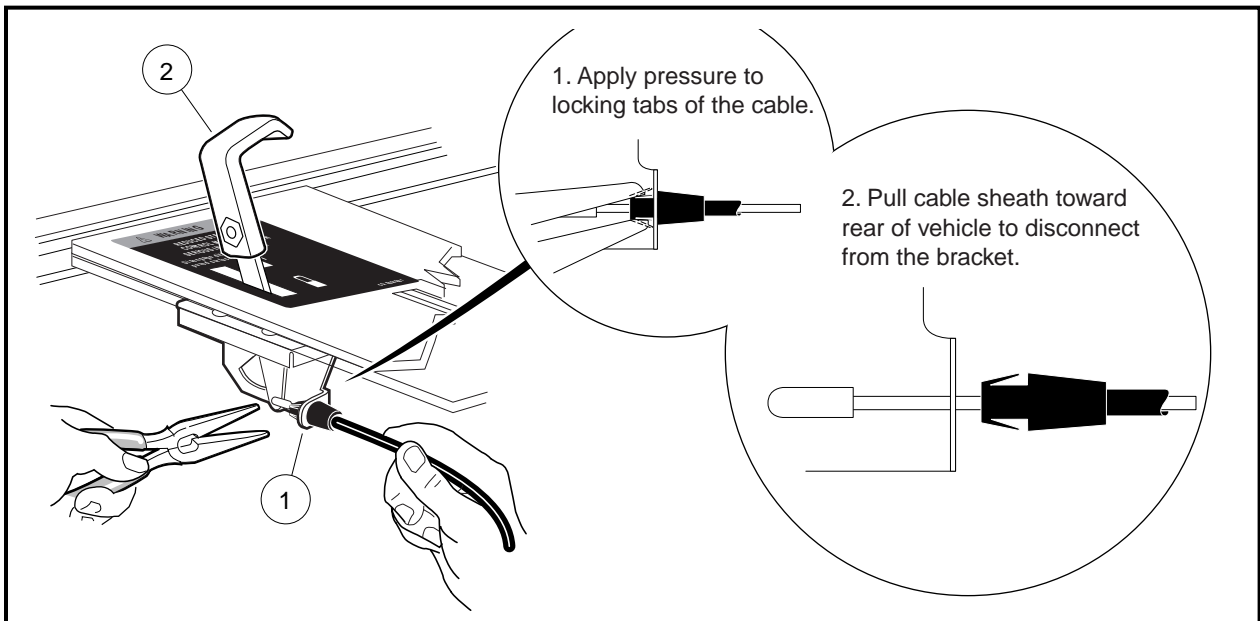

Figure 16-13 Differential Lock Cable Bracket

3.5. Remove the differential lock cable.

3.5.1. Place differential lock handle in the disengaged direction.

3.5.2. Using a pair of pliers, apply pressure to the locking tabs of the cable end (1) where it attaches to the differential lock handle mounting bracket (**Figure 16-13, Page 16-8**).

3.5.3. While maintaining pressure on the locking tabs, pull the differential lock cable toward the rear of the vehicle to disconnect the cable from the bracket (**Figure 16-13, Page 16-8**).

3.5.4. With handle in the engaged position and the cable disconnected from the bracket, rotate the cable connector toward the driver side of the vehicle to disconnect the cable from the differential lock lever (1) (**Figure 16-14, Page 16-9**).

3.5.5. Remove wire tie (6) securing the cable to the vertical support (**Figure 16-117, Page 16-50**).

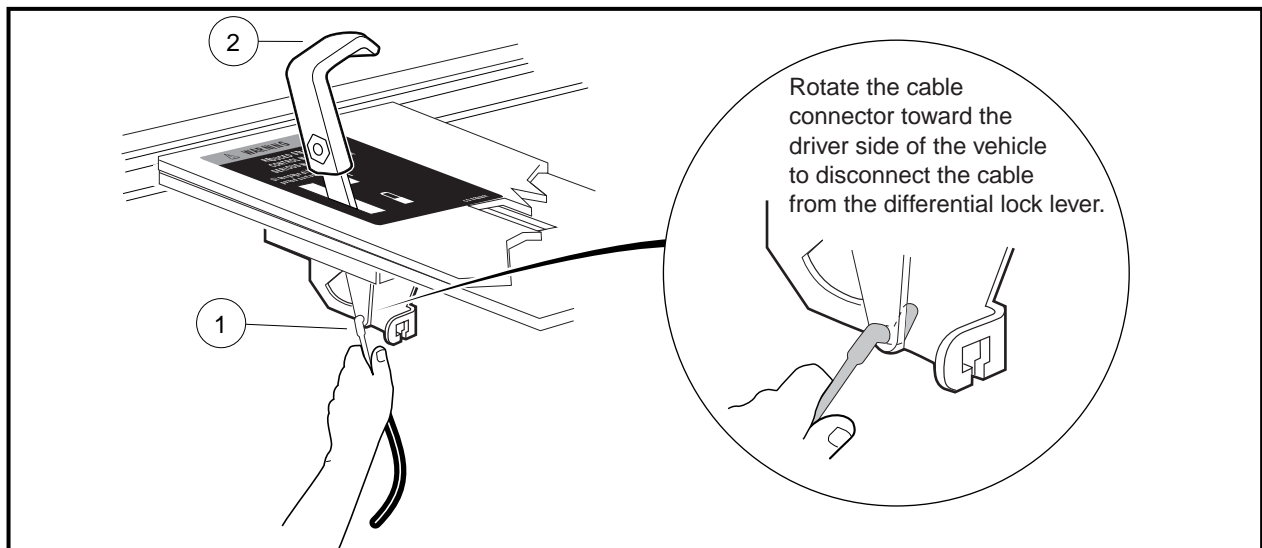

Figure 16-14 Differential Lock Cable Removal

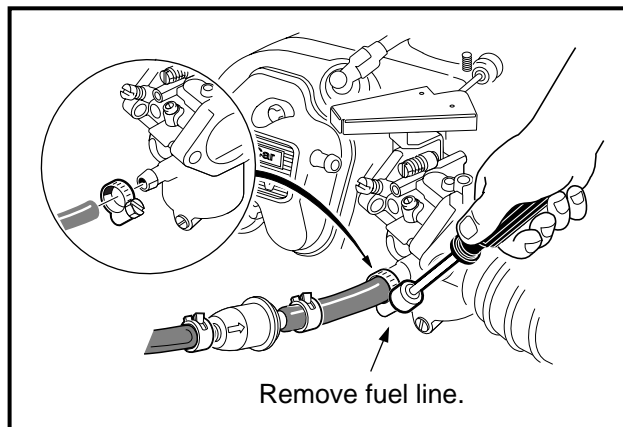

Figure 16-15 Fuel Line

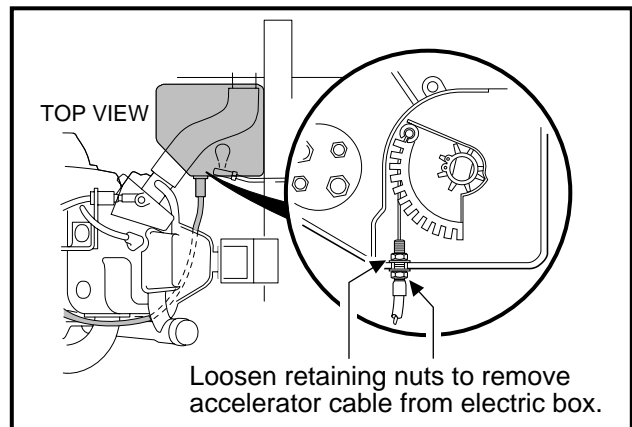

Figure 16-16 Accelerator Cable

3.6. Remove the cover from the electrical component box. Then loosen the hardware securing the accelerator cable to the box. Disconnect the cable from the actuator cam and remove it from the box (**Figure 16-16, Page 16-9**).

3.7. Disconnect the engine ground wire from the oil filler tube mounting bracket (**Figure 16-17, Page 16-10**).

Unitized Transaxle Removal, Continued:

- 3.8. Loosen nuts securing shifter cable to shifter cable mounting bracket. Then disconnect the shifter cable rod end from the shifter arm on the unitized transaxle and remove the cable from the cable mounting bracket (**Figure 16-18, Page 16-10**).
- 3.9. Remove screws (2) securing the Forward/Reverse shifter cable bracket (1) to transaxle and remove the shifter bracket (**Figure 16-40, Page 16-16**).
- 3.10. Loosen nut (3) and bolt (7) on transaxle shifter lever and remove lever from shaft (15) (**Figure 16-40, Page 16-16**).
- 3.11. Remove woodruff key (9) from shifter shaft (15) (**Figure 16-40, Page 16-16**).
- 3.12. Mark for proper reconnection and then disconnect the 6 gauge white wire (F2 post), 6 gauge black ground wire (A2 post), and 16 gauge yellow wire (DF post) from starter/generator (**Figure 16-19, Page 16-10**).

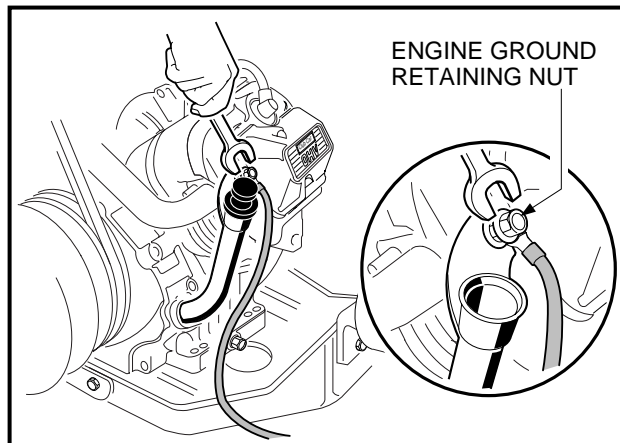

Figure 16-17 Engine Ground Wire

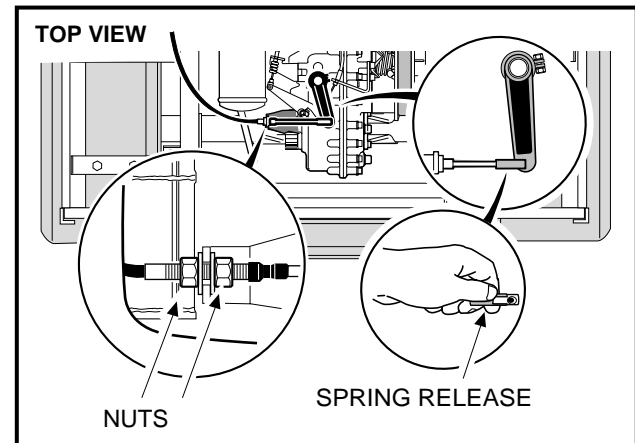

Figure 16-18 Shifter Cable

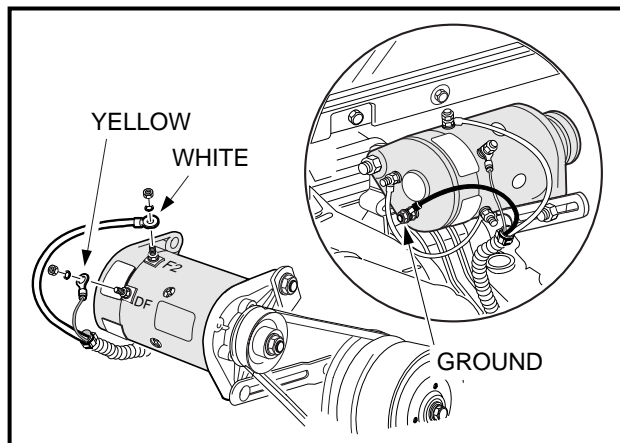

Figure 16-19 Generator Wires

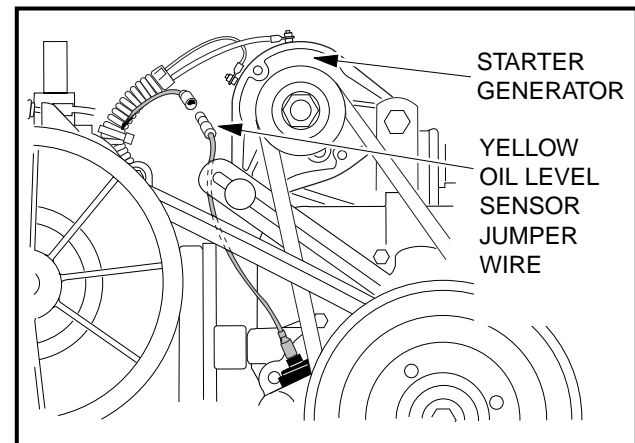

Figure 16-20 Oil Level Sensor Jumper Wire

- 3.13. Disconnect the engine oil level sensor wire (18 gauge yellow) at the bullet connector just to the rear of the starter/generator) (**Figure 16-20, Page 16-10**).
- 3.14. Disconnect the engine kill switch wire (18 gauge white/black) from the bullet connector at the lower right front of the engine (**Figure 16-21, Page 16-11**).
- 3.15. Cut away the wire ties securing the kill switch wire at the lower right front of the engine (below the exhaust header), the wire harness at the governor cable bracket, and the wire harness to the plate beneath the muffler.

4. Disconnect the brake hoses and park brake cables.
 - 4.1. Remove the park brake cable clip (1), hair spring cotter pin (2) and clevis pin (3) (**Figure 16-23, Page 16-11**).
 - 4.2. Remove the cable from the cable support bracket (**Figure 16-23, Page 16-11**).
 - 4.3. Remove the upper shock mounting hardware from the rear shock absorber and remove the shock absorber.
 - 4.4. Using a 3/8 inch **flare nut wrench**, remove the brake hose from the rear brake cluster. To avoid spilling brake fluid, lift the hose above the brake cluster assembly (**Figure 16-24, Page 16-11**).

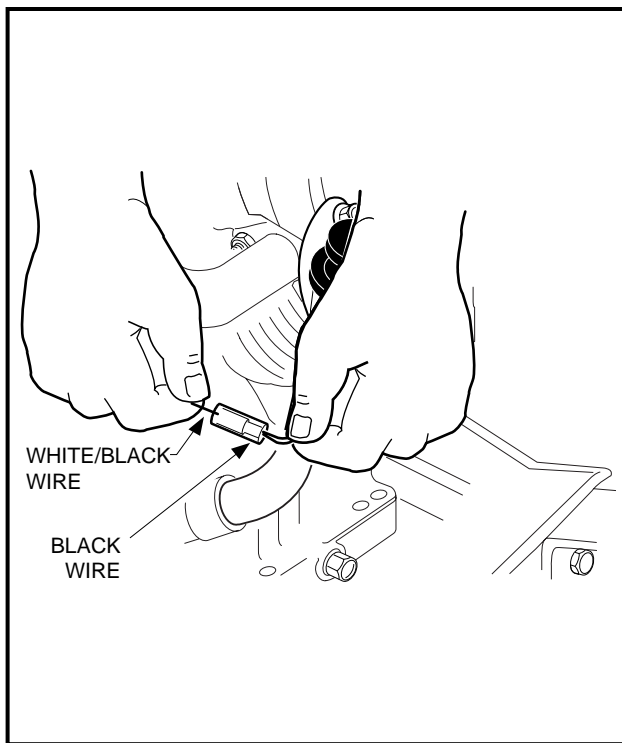

Figure 16-21 Engine Kill Switch Wire

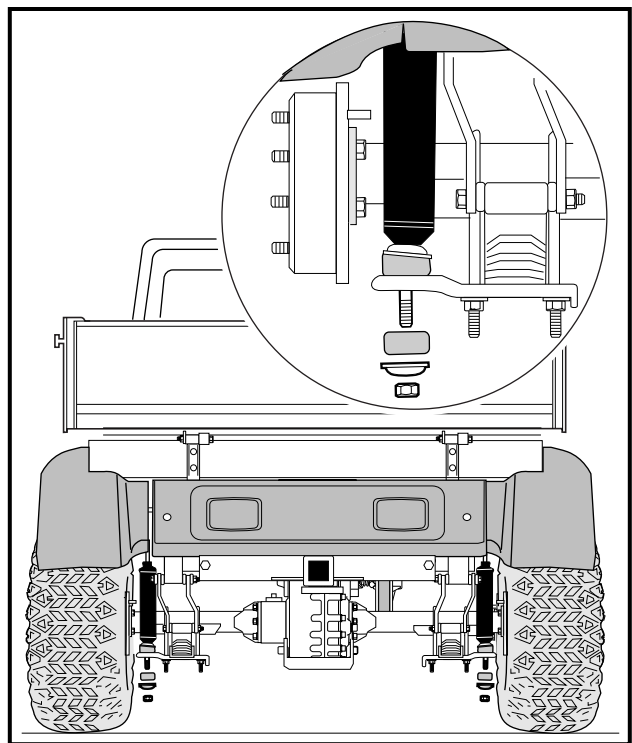

Figure 16-22 Shock Absorbers

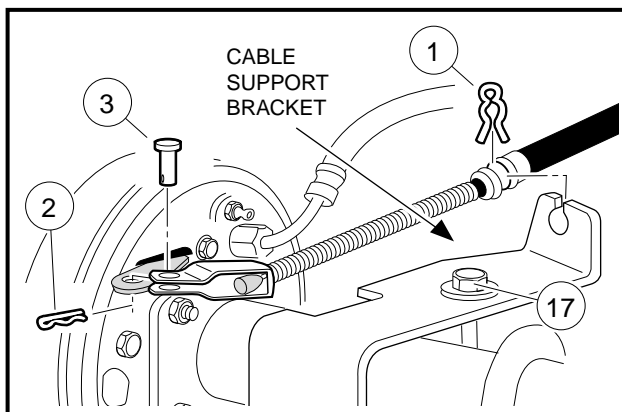

Figure 16-23 Park Brake Cable

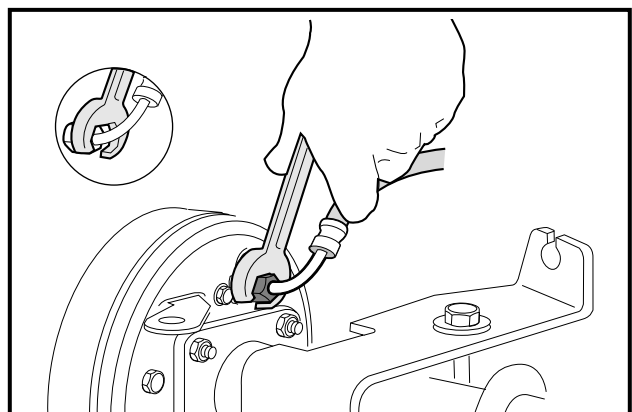
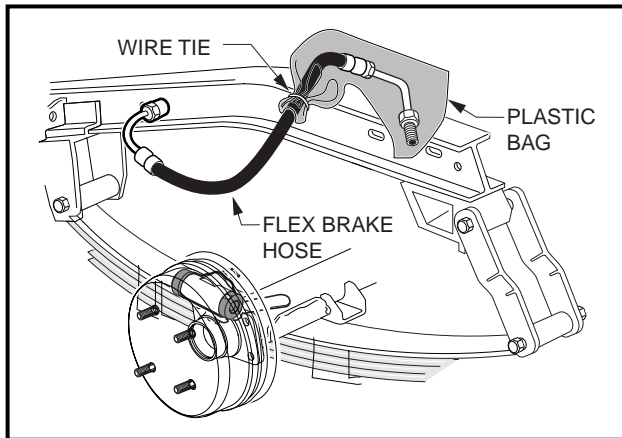
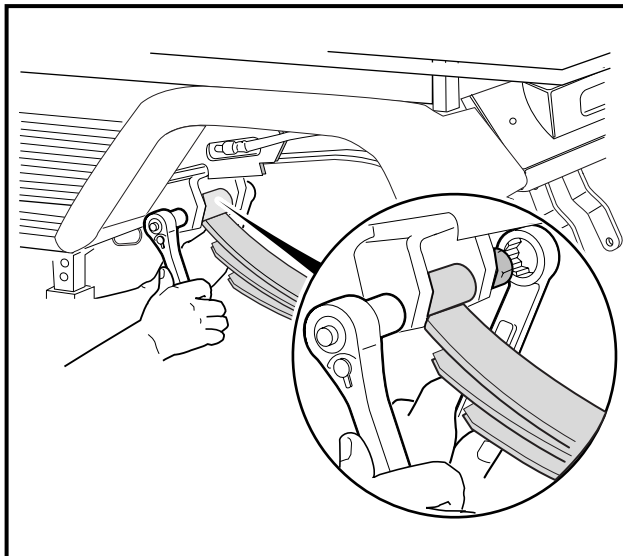
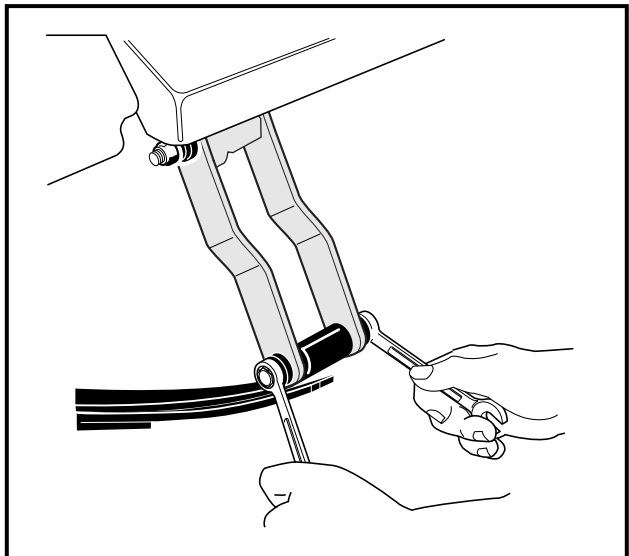

Figure 16-24 Brake Hose

Unitized Transaxle Removal, Continued:

- 4.5. To ensure that no dirt or trash enters the hydraulic braking system, place the hose fitting in a plastic bag and secure to the vehicle frame as shown (**Figure 16-25, Page 16-12**).
- 4.6. Repeat steps 4.1 through 4.5 for the opposite side of the vehicle.
5. Remove the lower shock mounting hardware from both rear shocks (**Figure 16-22, Page 16-11**).
6. Using a hydraulic jack placed under the transaxle (**Figure 16-28, Page 16-13**), raise the vehicle and place jack stands, set at approximately 17-1/2 inches (44.5 cm) in height, under the frame as shown (**Figure 16-29, Page 16-13**).
7. Lower the hydraulic jack just enough to relieve tension from the leaf springs.
8. Remove the bolts securing the leaf springs to their front mounts (**Figure 16-26, Page 16-12**).
9. Remove the bolts that secure the leaf springs to the shackles (**Figure 16-27, Page 16-12**).

**Figure 16-25 Cover Brake Hose Fitting****Figure 16-26 Spring Retainer Bolts****Figure 16-27 Rear Shackles**

10. With the hydraulic jack, slowly lower the powertrain until both of the rear tires are resting on the floor.
11. Carefully lift the snubber out of the snubber bracket in the vehicle frame and lower it to the floor (**Figure 16-30, Page 16-13**). The powertrain should be completely disconnected from the vehicle and resting on the floor.
12. Grasp the ends of the leaf springs at the rear of the vehicle and roll the powertrain out from under the vehicle (**Figure 16-31, Page 16-13**).
13. Place blocks under the engine pan so they will completely support the engine and keep it **level to the floor** (**Figure 16-32, Page 16-14**). See following **NOTE**.

NOTE: Place the blocks so they will support the engine when the transaxle is detached and moved away from the engine.

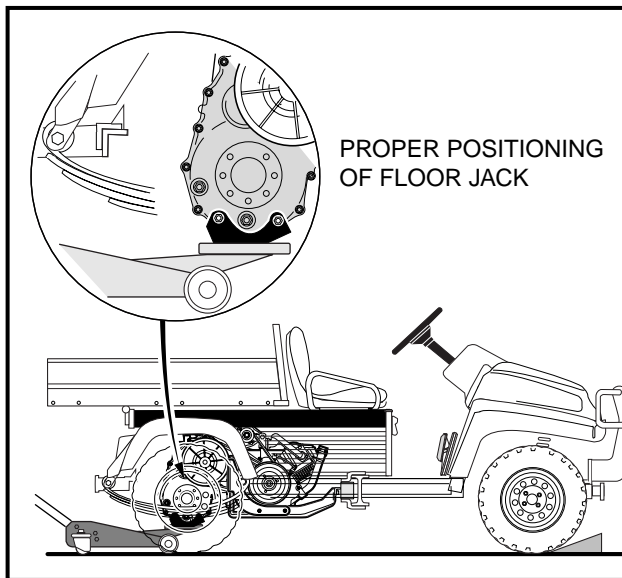

Figure 16-28 Raise Vehicle

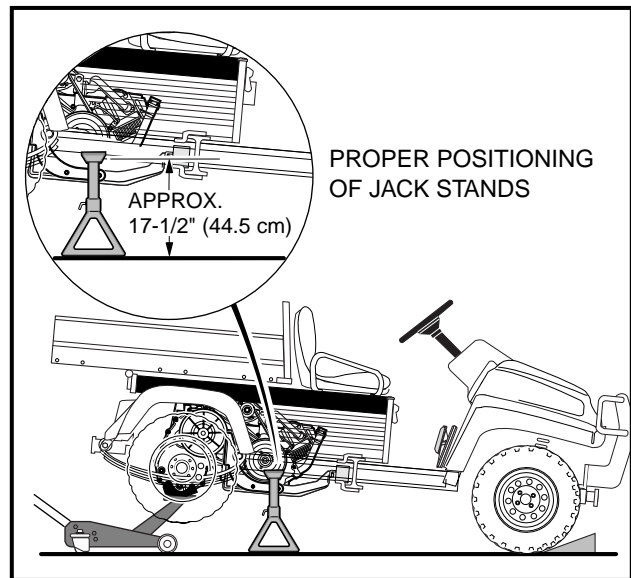

Figure 16-29 Position Jack Stands

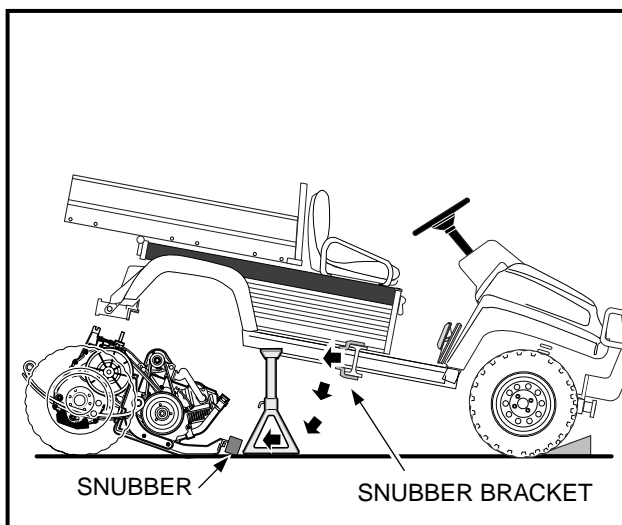

Figure 16-30 Snubber

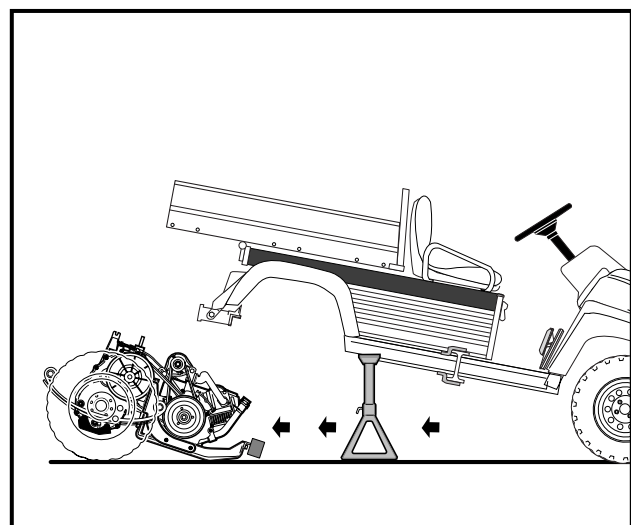

Figure 16-31 Remove Powertrain

Unitized Transaxle Removal, Continued:

14. Remove the drive belt.
 - 14.1. Grasp belt midway between drive and driven clutch and pull up on belt to force the driven clutch sheaves apart. Roll the belt counterclockwise while pulling it off driven clutch (**Figure 16-33, Page 16-14**).
15. Remove the driven clutch retaining bolt and remove the driven clutch from the unitized transaxle (**Figure 16-34, Page 16-14**).
16. Loosen, but do not remove, the governor arm retaining bolt. Remove the governor arm from the shaft (**Figure 16-35, Page 16-14**).
17. Remove screws securing the governor cable bracket to transaxle (**Figure 16-36, Page 16-15**).
18. Remove screws securing the accelerator cable bracket to transaxle (**Figure 16-37, Page 16-15**).

NOTE: The governor cable and the accelerator cable should remain attached to the governor arm.

19. Remove the two bolts that secure the differential lock cable bracket to the transaxle housing and unhook the cable spring from the differential lock arm (**Figure 16-38, Page 16-15**).

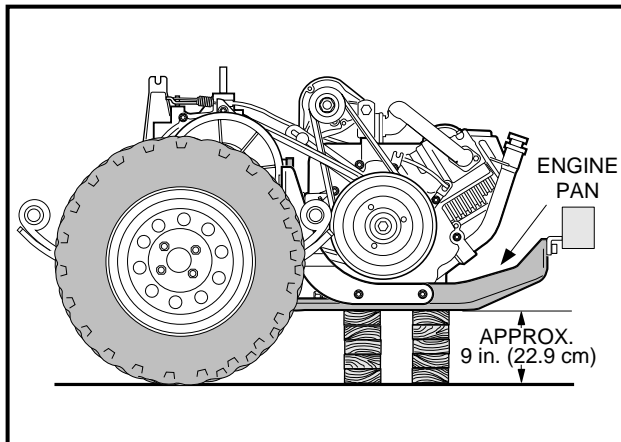

Figure 16-32 Position Powertrain

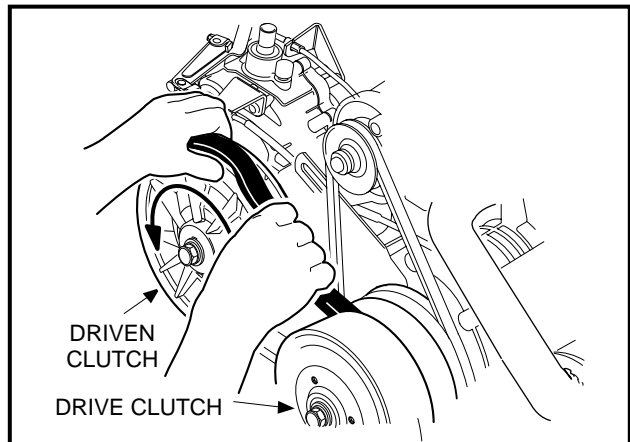

Figure 16-33 Remove Drive Belt

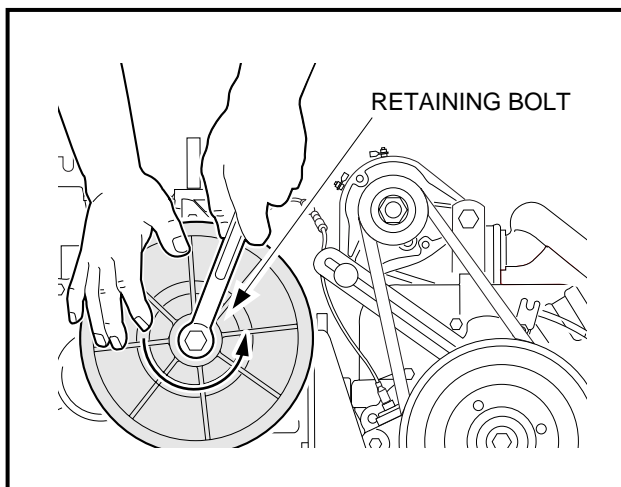

Figure 16-34 Driven Clutch

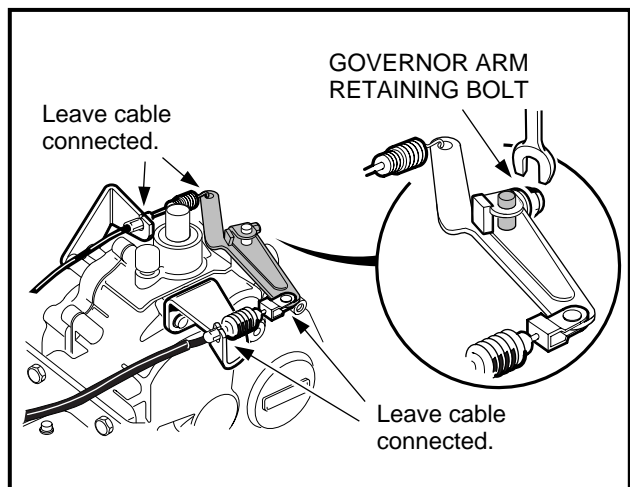

Figure 16-35 Governor Arm

20. Remove the six bolts mounting the unitized transaxle to the engine.
 - 20.1. Remove four transaxle mounting bolts (one at each corner of the transaxle mounting plate) as shown (**Figure 16-39, Page 16-15**).
 - 20.2. Remove two middle transaxle mounting nuts as shown (**Figure 16-39, Page 16-15**).
21. Remove leaf springs, wheels and brake assemblies from the transaxle.

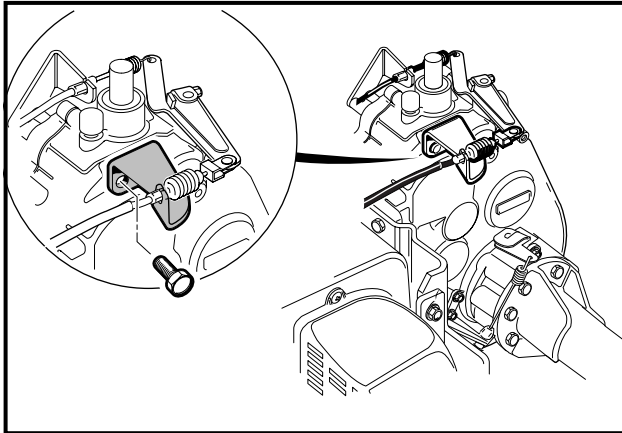

Figure 16-36 Governor Cable Bracket

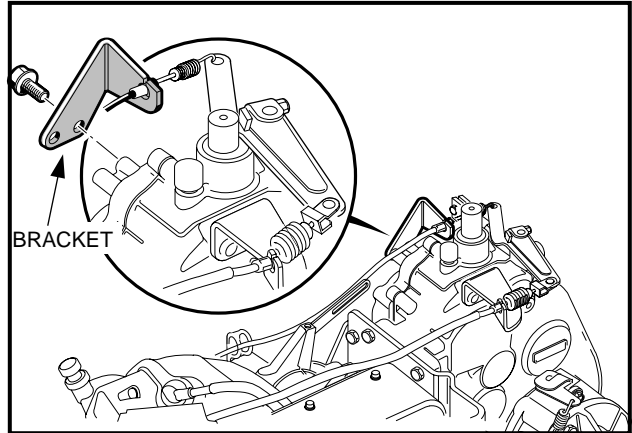

Figure 16-37 Accelerator Cable Bracket

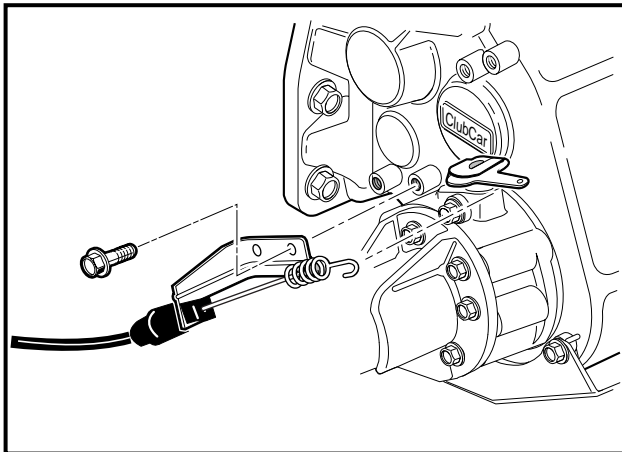

Figure 16-38 Differential Lock Arm and Bracket

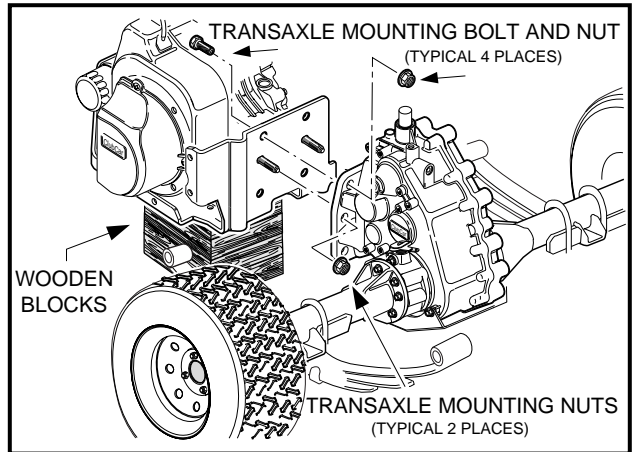

Figure 16-39 Transaxle Mounting

UNITIZED TRANSAXLE DISASSEMBLY

Read **DANGER** and **WARNING** on page 16-1.

NOTE: The following information provides instructions for disassembling the unitized transaxle; however, the transaxle case can be separated and gears accessed without removing the axles or axle tubes from the case.

1. Remove the drain plug and gasket. Drain and dispose of the oil properly (**Figure 16-2, Page 16-2**).
2. Using 90° (.090 tip) internal snap ring pliers, remove the internal retaining rings (**Figure 16-5, Page 16-5**) from the axle tubes.
3. Pull the axles (82 and 83) out of the axle tubes (**Figure 16-4, Page 16-4**).

Unitized Transaxle Disassembly, Continued:

4. Remove seven bolts (92 and 93), mounting each axle tube to the transaxle case (**Figure 16-4, Page 16-4**). Then remove axle tubes from the transaxle case and differential lock housing. **See following NOTE.**

NOTE: It may be necessary to tap the axle tube with a rubber or plastic mallet to break it free from the transaxle case or differential lock housing.

5. If necessary, remove the brake cable brackets from the axle tubes:
 - 5.1. Remove the bolt (17), washers, and lock nut from the bracket (**Figure 16-23, Page 16-11**).
6. Remove the differential lock housing (36) from the transaxle case (27) (**Figure 16-40, Page 16-16**).
7. Remove the four bolts (35) and the differential guard (34) from the transaxle.
8. Remove the fifteen bolts (28) that hold the transaxle housing together (**Figure 16-40, Page 16-16**).

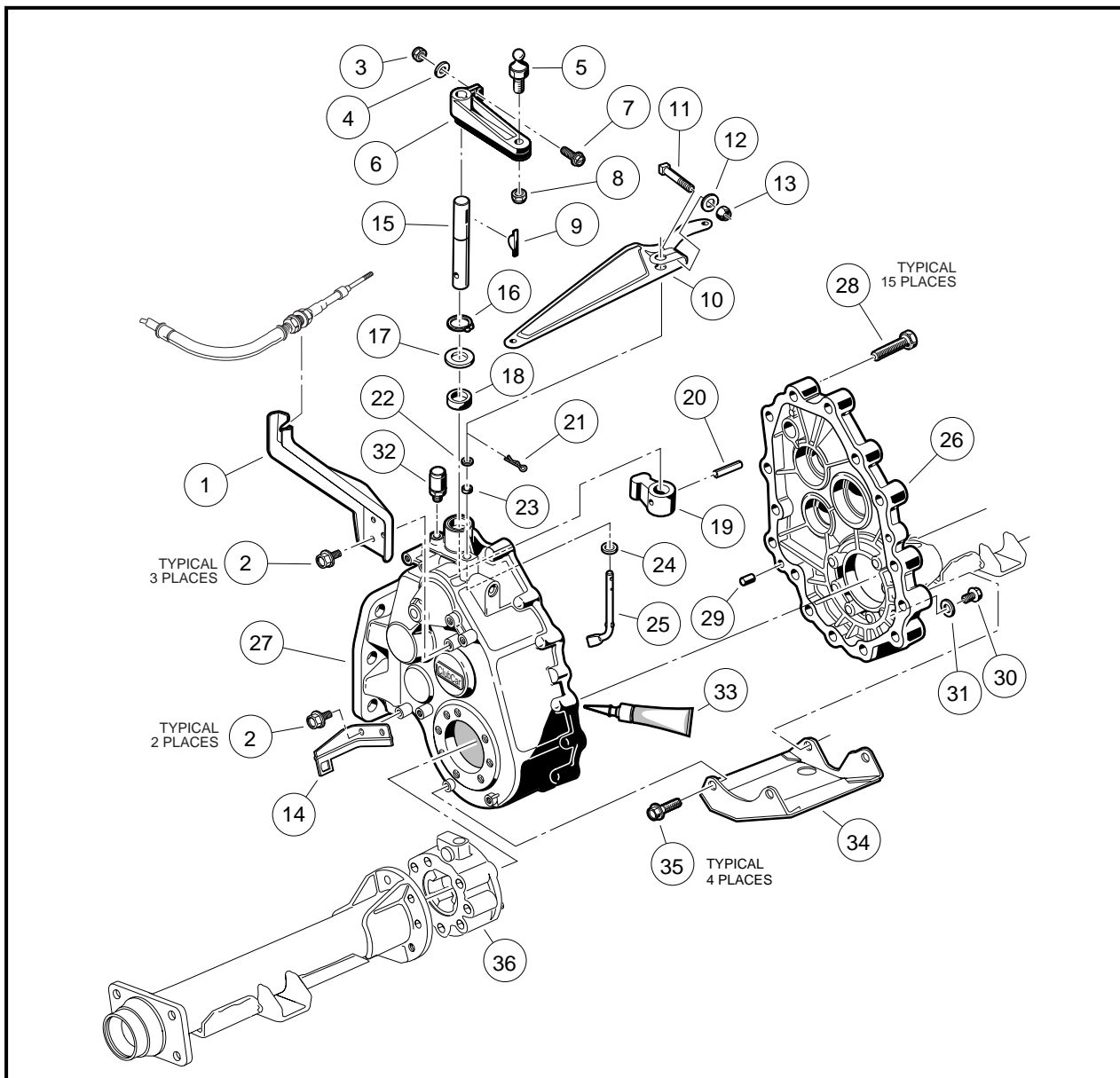

Figure 16-40 Transaxle Gear Casing and Brackets

- The unitized transaxle is equipped with a slot for prying the housing apart. Use the slot to open the case. Pull the housing apart, making sure all gear assemblies inside the transaxle stay together in one (either) side of the case. **See following CAUTION.**

⚠ CAUTION

- To prevent damage to the mating seal surfaces of the case, use care when separating the halves.
- Turn the case section containing the gearing on edge as shown (**Figure 16-41, Page 16-17**). While holding it in this position, gently rock all the gear assemblies to slightly loosen them in their seating.

⚠ CAUTION

- To prevent damage to the gears, use extreme care when handling them.
- When all the gear assemblies are slightly loosened, remove the differential gear case assembly by gently rocking it while pulling it from the case (**Figure 16-42, Page 16-17**).
 - Continue to rock and loosen the remaining gear assemblies until the intermediate gear assembly can be removed from the case. Then remove the idler shaft assembly (**Figure 16-43, Page 16-18**).
 - Remove the synchronizer gear assembly and shifter fork assembly as a unit from the case (**Figure 16-43, Page 16-18**).
 - Use a seal puller (CCI 1012809) or rolling head prybar to remove the input shaft oil seal from the case (**Figure 16-44, Page 16-18**).
 - Remove the oil flow guide from the case (**Figure 16-45, Page 16-18**).

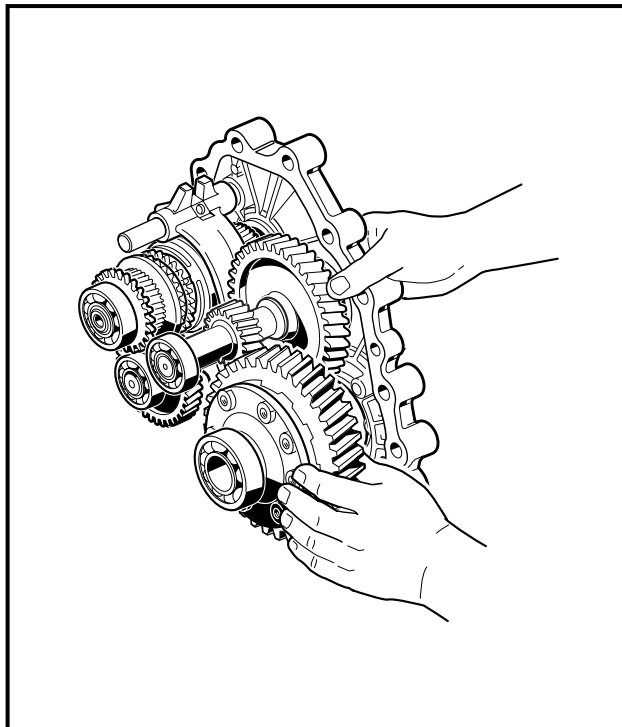

Figure 16-41 Loosen Gears

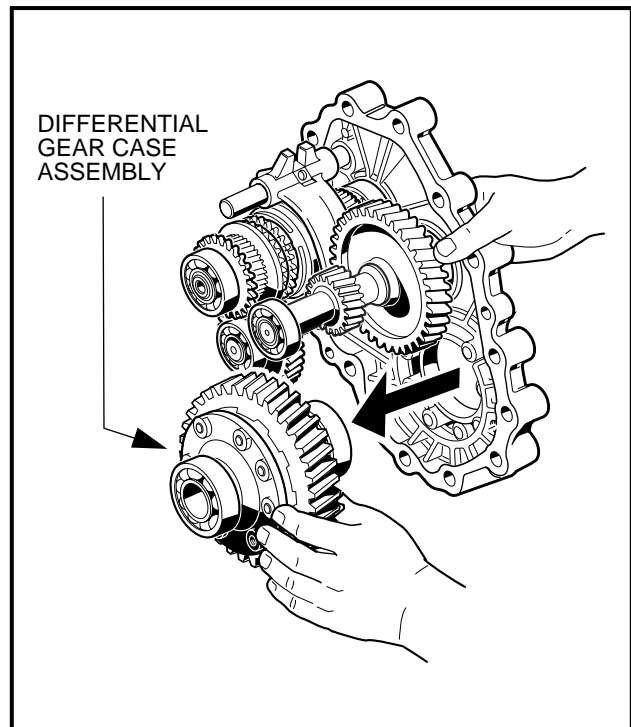

Figure 16-42 Remove Differential Gear Case

Unitized Transaxle Disassembly, Continued:

16. Remove the shifter shaft and oil seal from the case (**Figure 16-45, Page 16-18**).
 - 16.1. Use snap ring pliers (.047 tip) to remove the retaining ring (16) on the shifter shaft (**Figure 16-40, Page 16-16**).
 - 16.2. Remove flat washer (17) from the shifter shaft on the outside of the case as shown, then remove the shifter shaft by pushing it through the case toward the interior of transaxle (**Figure 16-40, Page 16-16**).
 - 16.3. Use a seal puller to remove the shifter shaft oil seal (18) from the case (**Figure 16-40, Page 16-16**).
17. Remove the breather (32) from the case (**Figure 16-40, Page 16-16**).
18. Remove the governor assembly from the case.
 - 18.1. Remove the cotter pin (21) and flat washer (22) from the pivot arm (25) (**Figure 16-40, Page 16-16**).

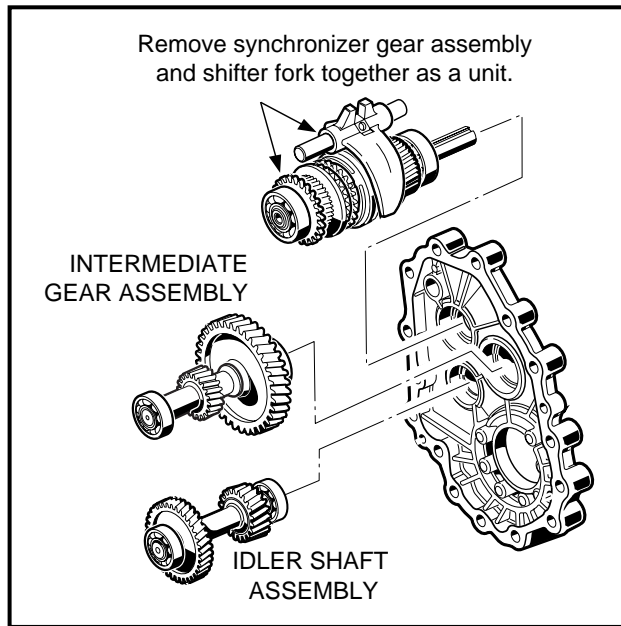

Figure 16-43 Remove Intermediate Gear

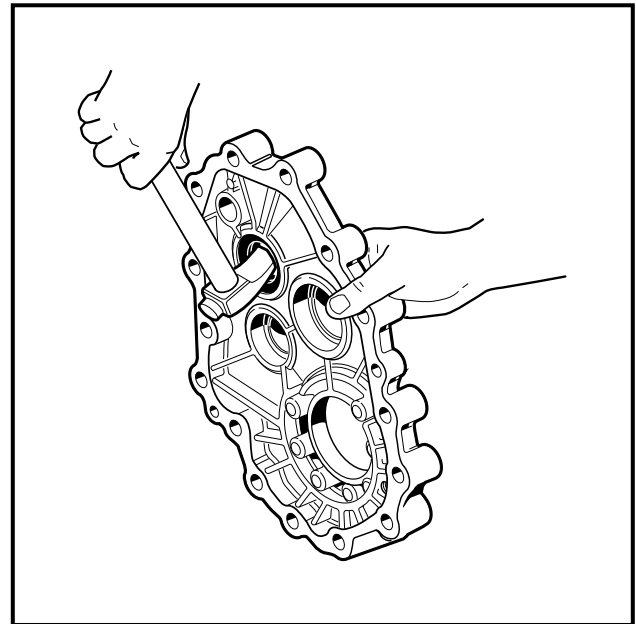

Figure 16-44 Input Shaft Oil Seal

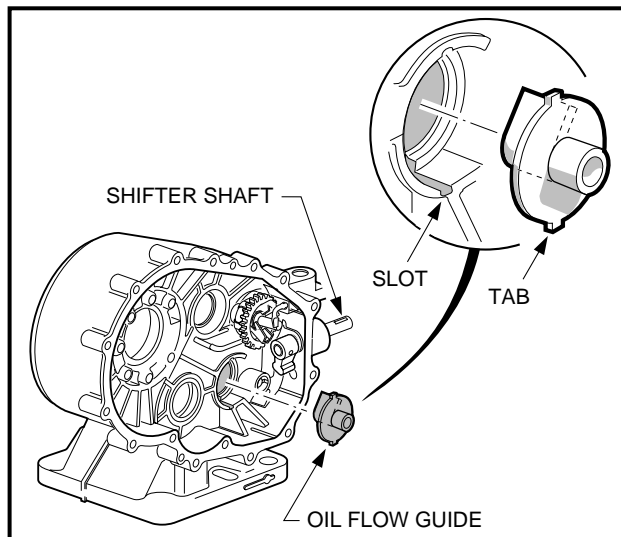

Figure 16-45 Oil Flow Guide

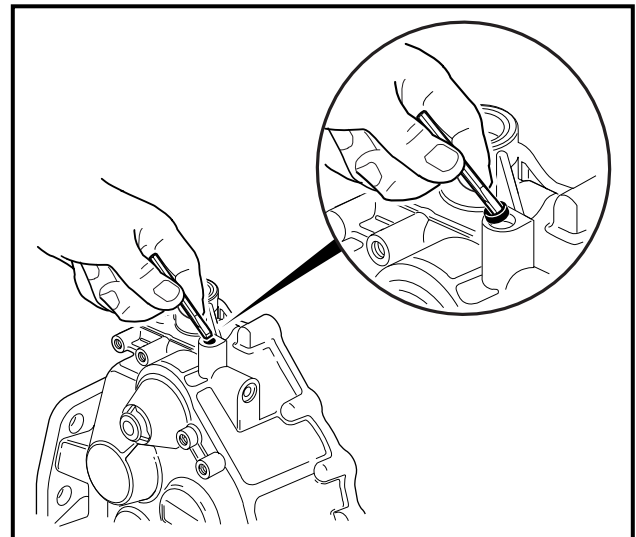

Figure 16-46 Pivot Arm Oil Seal

- 18.2. Remove the pivot arm (25) by pulling it through the wall to the interior of the case.
- 18.3. Use a small chisel or similar pointed instrument to pry the pivot arm oil seal (23) (**Figure 16-40, Page 16-16**) out of the case (**Figure 16-46, Page 16-18**).
- 18.4. Remove the governor gear assembly (66 and 67) and flat washer (65) (**Figure 16-48, Page 16-20**) by lightly tapping the gear shaft through the case wall, from the outside, with a hammer and drift. **See also Figure 16-49, Page 16-21.**

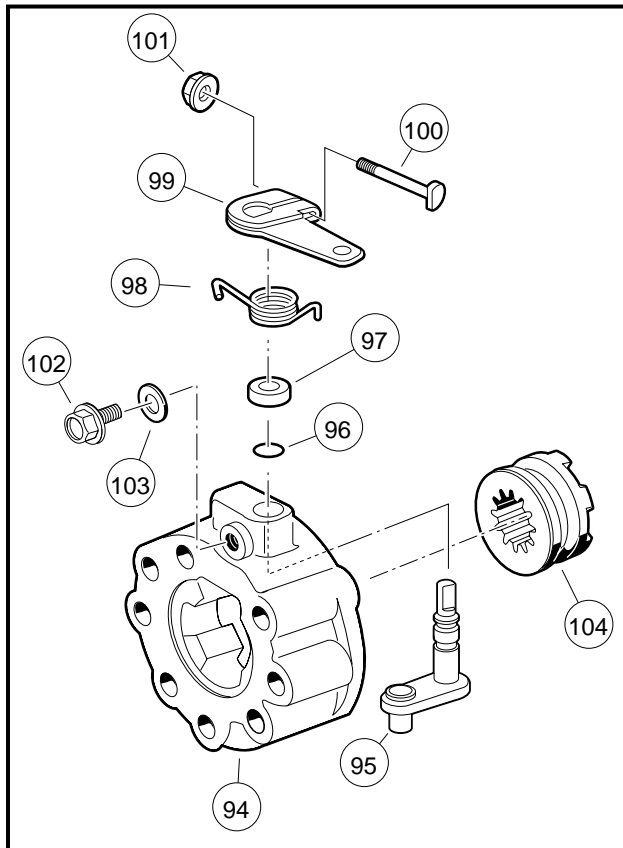

Figure 16-47 Differential Lock Housing Disassembly

COMPONENT DISASSEMBLY

Read **DANGER** and **WARNING** on page 16-1.

DIFFERENTIAL GEAR LOCK HOUSING DISASSEMBLY

1. Rotate the arm (99) and remove the differential lock cog (104) (**Figure 16-47, Page 16-19**).
2. Loosen but do not remove the differential lock arm retaining nut (101) and remove the arm (99) and spring (98) from the differential lock shaft (95) (**Figure 16-47, Page 16-19**).
3. Remove the spacer (97) from the differential lock shaft (95) (**Figure 16-47, Page 16-19**).
4. Remove the shaft retaining screw (102) and washer (103) from the differential lock housing (**Figure 16-47, Page 16-19**).
5. Press the shaft (95) toward the center of the differential lock housing and remove the shaft (95) from the housing (94) (**Figure 16-47, Page 16-19**).
6. If necessary, gently pry the O-ring from the groove in the differential lock shaft with a small screwdriver (**Figure 16-73, Page 16-31**).

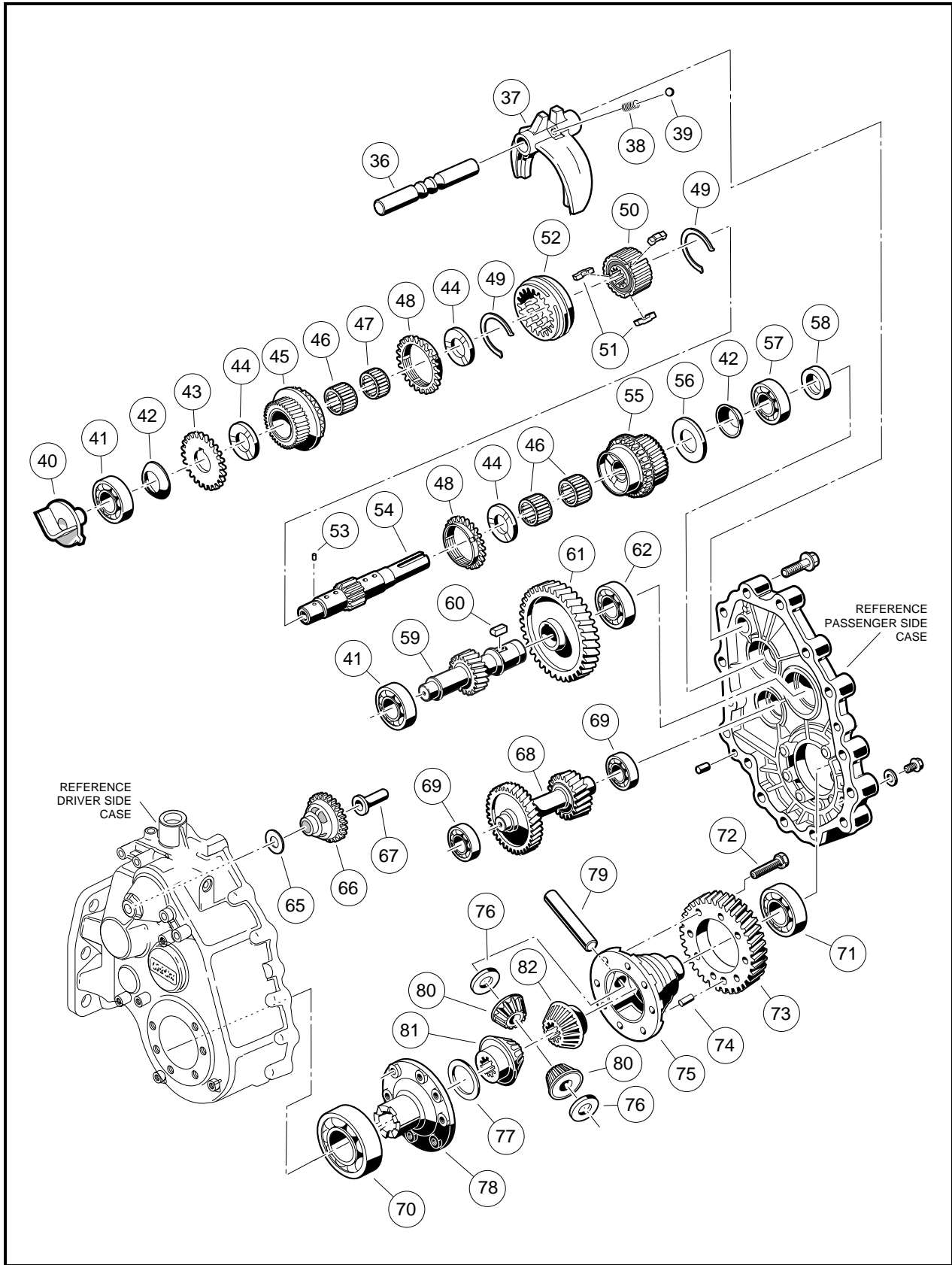

Figure 16-48 Unitized Transaxle with Differential Lock

GOVERNOR GEAR DISASSEMBLY

NOTE: It will be necessary to disassemble the governor gear assembly in order to reinstall it into the transaxle case.

1. Secure the governor gear assembly in a vise as shown. Wrap shaft in a cloth to prevent damage (**Figure 16-50, Page 16-21**).
2. Use two small screwdrivers to pry the gear and flyweight off the shaft as shown (**Figure 16-50, Page 16-21**).

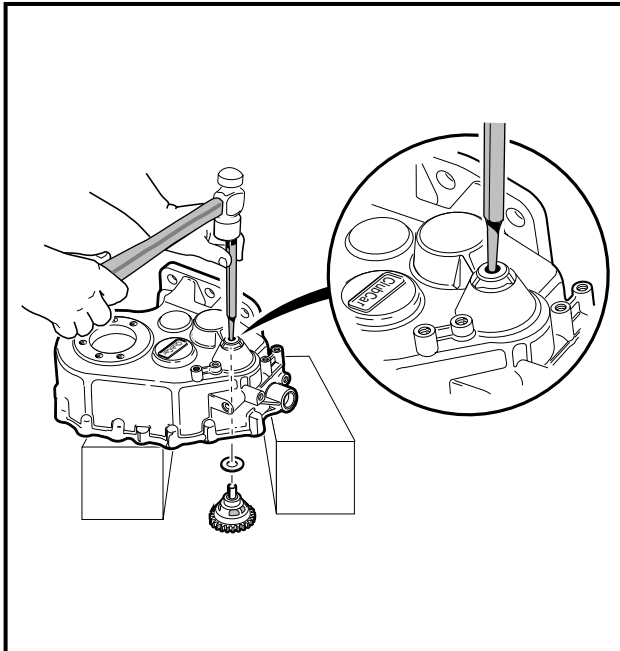

Figure 16-49 Remove Governor Gear

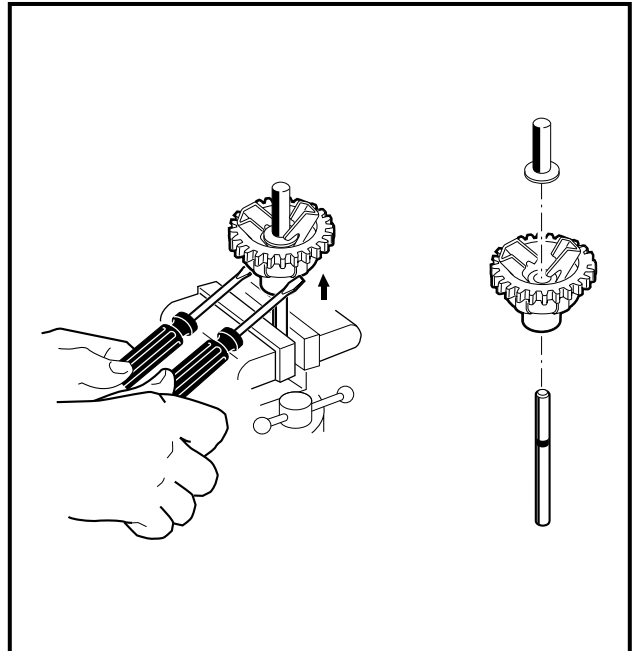

Figure 16-50 Pry Gear from Shaft

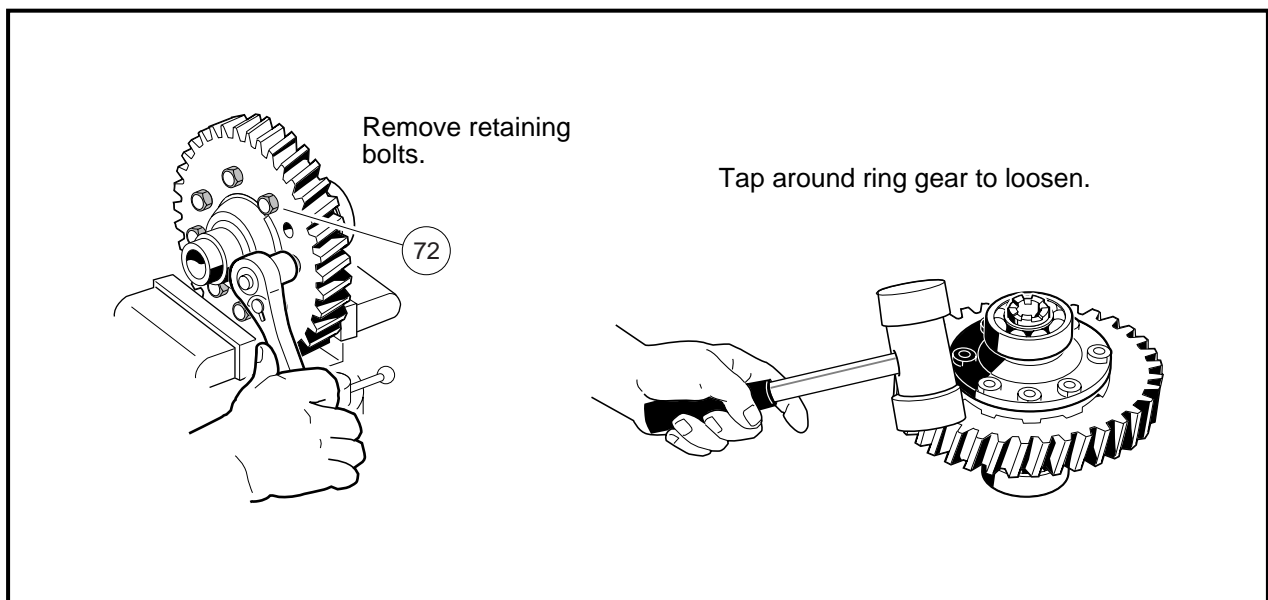

Figure 16-51 Remove Ring Gear

DIFFERENTIAL GEAR CASE DISASSEMBLY

⚠ CAUTION

- Mark parts for identification as they are disassembled. Parts must be reassembled in their original locations and orientations.

1. Remove eight ring gear retaining bolts (72) (**Figure 16-51, Page 16-21**), and remove the ring gear from the assembly. It may be necessary to tap the ring gear off with a plastic or rubber mallet (**Figure 16-51, Page 16-21**). See following NOTE.

NOTE: Because Loctite was applied to the bolts during assembly, it may be necessary to place the differential gear case in a vise to remove the bolts.

2. Pull the cover (78) and thrust plate (77) from the differential gear carrier case (**Figure 16-48, Page 16-20**).
3. Remove the differential gear (81) from the differential gear carrier case (**Figure 16-48, Page 16-20**).
4. Remove the differential pin (79) (**Figure 16-48, Page 16-20**) by pushing it through from one side (**Figure 16-52, Page 16-22**). Remove the two differential idler gears (80) and two idler gear thrust plates (76) (**Figure 16-4, Page 16-4**) as the pin is driven through. See following NOTE.

NOTE: It may be necessary to drive the differential pin out with a hammer and punch.

5. Remove the differential gear (82) from the carrier case (**Figure 16-48, Page 16-20**).
6. If the bearings (70 and 71) are to be removed, place a bearing puller wedge attachment (CCI 1012812) between the bearing and gear case (75) (**Figure 16-48, Page 16-20**) and press the bearing off as shown (**Figure 16-53, Page 16-22**). Repeat the process for the bearing (70) on the carrier cover (78) (**Figure 16-48, Page 16-20**). See following CAUTION.

⚠ CAUTION

- Do not tighten the bearing puller wedge attachment against the shaft. This could damage the shaft.

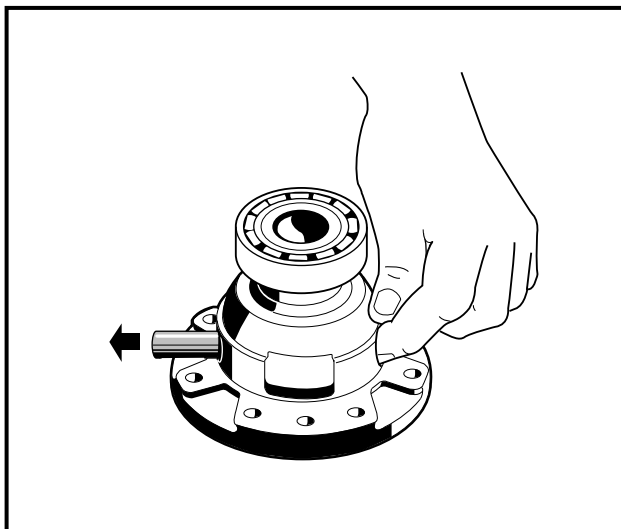

Figure 16-52 Differential Pin

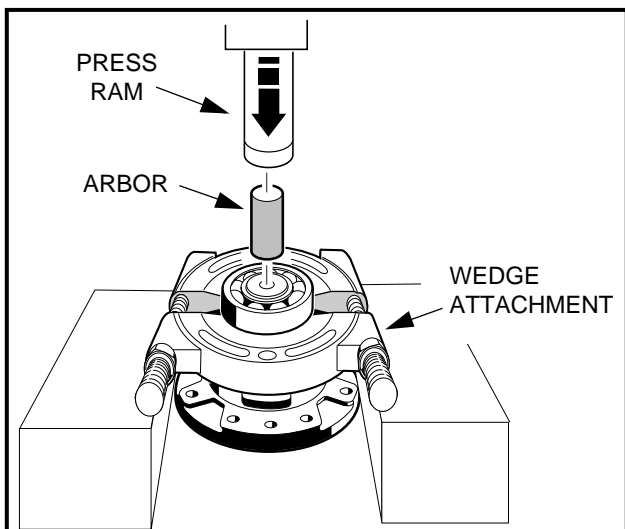

Figure 16-53 Remove Bearing

SHIFTER FORK DISASSEMBLY

1. Push the shift rod (36) out of the shifter fork (37) (**Figure 16-48, Page 16-20**).
2. Shake the shifter fork (37) to remove the spring (38) and ball (39) (**Figure 16-48, Page 16-20**).

SYNCHRONIZER GEAR DISASSEMBLY

⚠ CAUTION

- Mark parts for identification as they are disassembled. Parts must be reassembled in their original locations and orientations.
- Do not tighten the bearing puller wedge attachment against the shaft. This could damage the shaft.

1. Place a bearing puller wedge attachment (CCI 1012812) between the bearing (41) and spur (governor drive) gear (43) (**Figure 16-48, Page 16-20**), then press the bearing off the input shaft as shown (**Figure 16-54, Page 16-23**). See preceding CAUTION.
2. Pull the spring washer (42), spur gear (43), dowel pin (53), thrust plate (44), input gear assembly (45), large needle bearing (46), small needle bearing (47), synchronizer ring (48), and thrust plate (44) from the input shaft (**Figure 16-48, Page 16-20**).
3. Place a bearing puller wedge attachment (CCI 1012812) between the bearing (57) and input gear assembly (55) (**Figure 16-48, Page 16-20**), then press the bearing off the input shaft as shown (**Figure 16-55, Page 16-23**). See following CAUTION.

⚠ CAUTION

- Do not tighten the bearing puller wedge attachment against the shaft. This could damage the shaft.
4. Pull the spring washer (42), thrust washer (56), input gear assembly (55), two needle bearings (46), thrust plate (44), and synchronizer ring (48) from the input shaft (**Figure 16-48, Page 16-20**).

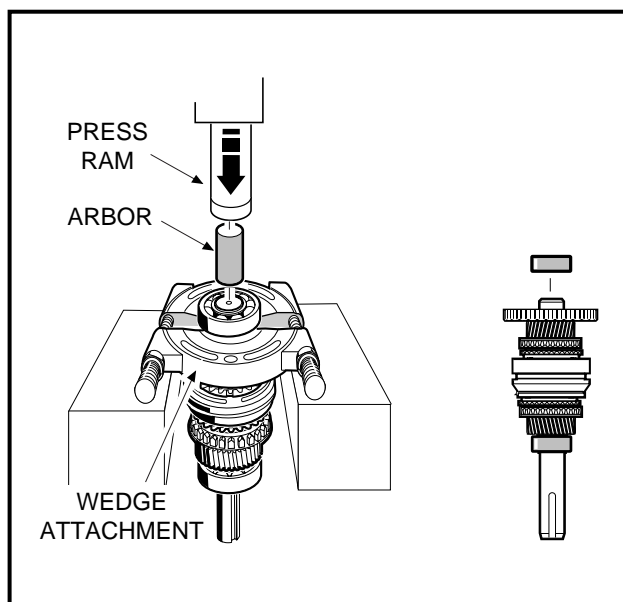

Figure 16-54 Remove Bearing

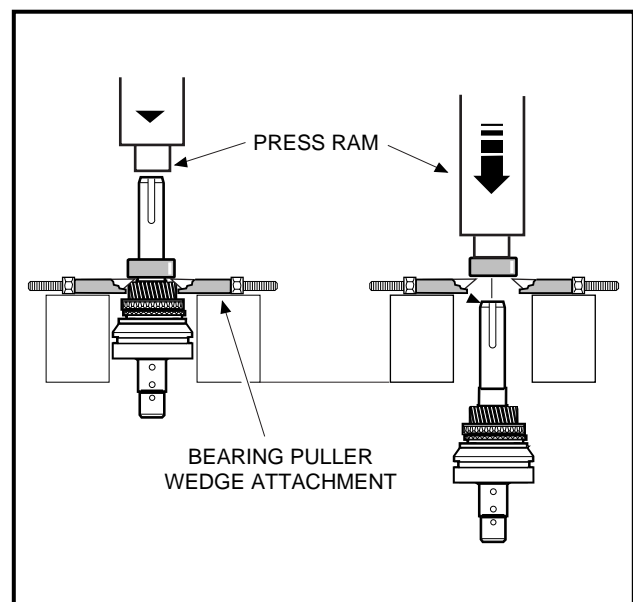

Figure 16-55 Remove Bearing

5. Use a small flat-blade screwdriver to remove two synchronizer springs (snap rings) (49), and then slide the synchronizer clutch hub (52) from the input shaft (54) (**Figure 16-48, Page 16-20**). See following **NOTE**.

NOTE: There are three synchronizer inserts (51) set into slots in the synchronizer sleeve (50) (**Figure 16-48, Page 16-20**). These may fall free when the synchronizer clutch hub (52) is removed. Do not lose these inserts.

6. Remove the three synchronizer inserts (51) from the synchronizer sleeve (**Figure 16-48, Page 16-20**).
7. Press the synchronizer sleeve (50) from the input shaft (**Figure 16-48, Page 16-20**).

INTERMEDIATE GEAR DISASSEMBLY

1. Place bearing puller wedge attachment (CCI 1012812) between bearing (41) and shaft/gear (59) (**Figure 16-48, Page 16-20**), then press bearing off shaft (**Figure 16-56, Page 16-24**). See following **CAUTION**.

⚠ CAUTION

- Do not tighten the bearing puller wedge attachment against the shaft. This could damage the shaft.
2. Place the bearing puller wedge attachment under the bearing (62) and press the bearing from the shaft (**Figure 16-48, Page 16-20**). See following **CAUTION**.
 3. Press the gear (61) from the shaft (59), then remove the key (60) (**Figure 16-48, Page 16-20**).

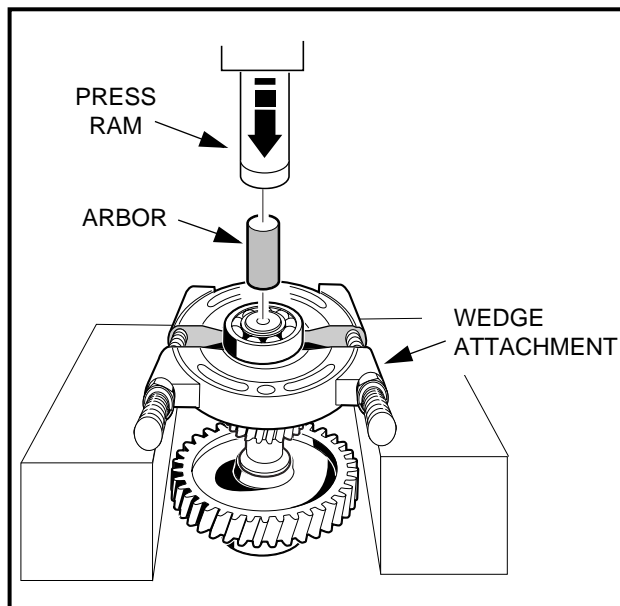

Figure 16-56 Remove Bearing

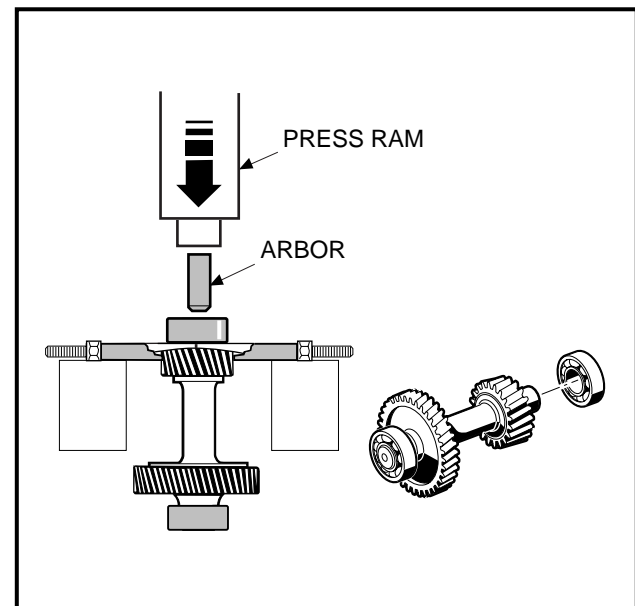

Figure 16-57 Remove Bearing

IDLER SHAFT DISASSEMBLY

1. Place a bearing puller wedge attachment (CCI 1012812) between the bearing (69) (**Figure 16-48, Page 16-20**) and the small gear on the idler shaft (68) (**Figure 16-48, Page 16-20**), then press the bearing off the shaft as shown (**Figure 16-57, Page 16-24**). See following **CAUTION**.

▲ CAUTION

- Do not tighten the bearing puller wedge attachment against the shaft. The shaft could be damaged when pressing the bearing off.
2. Place a bearing puller wedge attachment (CCI 1012812) between the bearing and the larger gear on the idler shaft, then press the bearing off the shaft (68) (**Figure 16-48, Page 16-20**) as shown (**Figure 16-58, Page 16-25**).

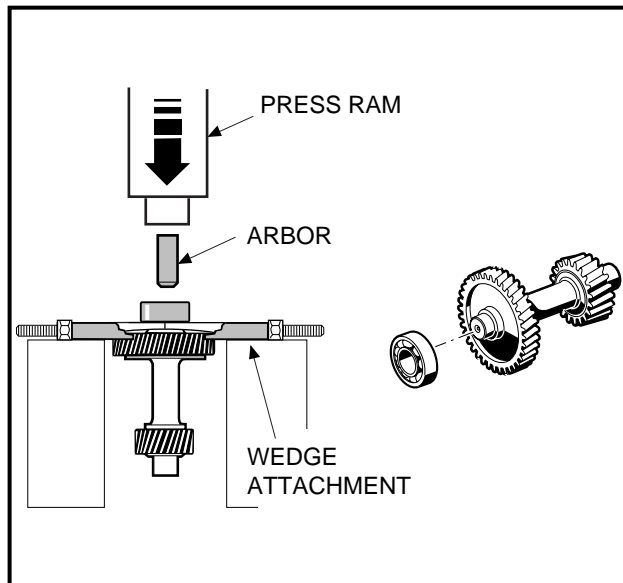

Figure 16-58 Remove Idler Shaft

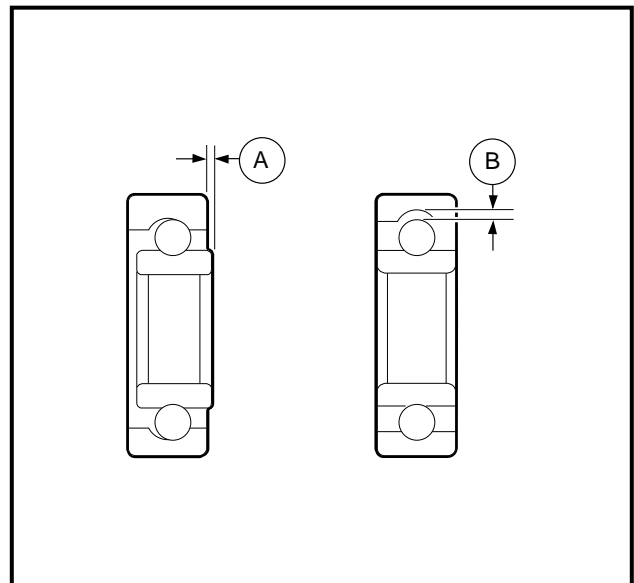

Figure 16-59 Inspect Bearings

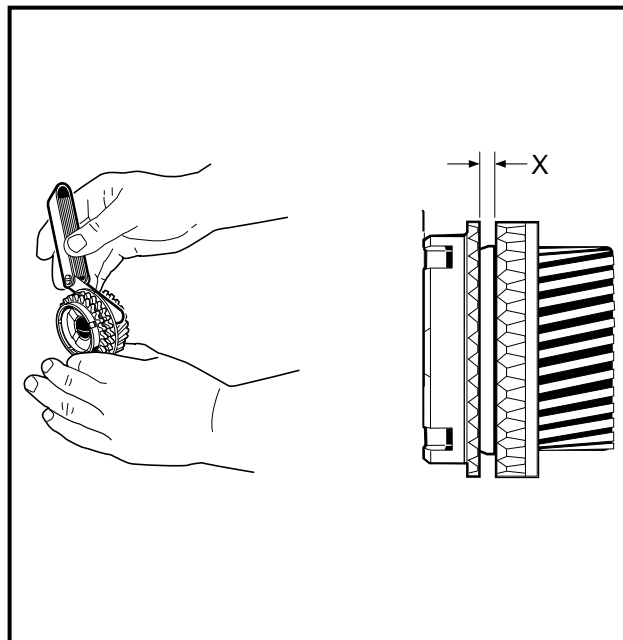

Figure 16-60 Synchro. Ring

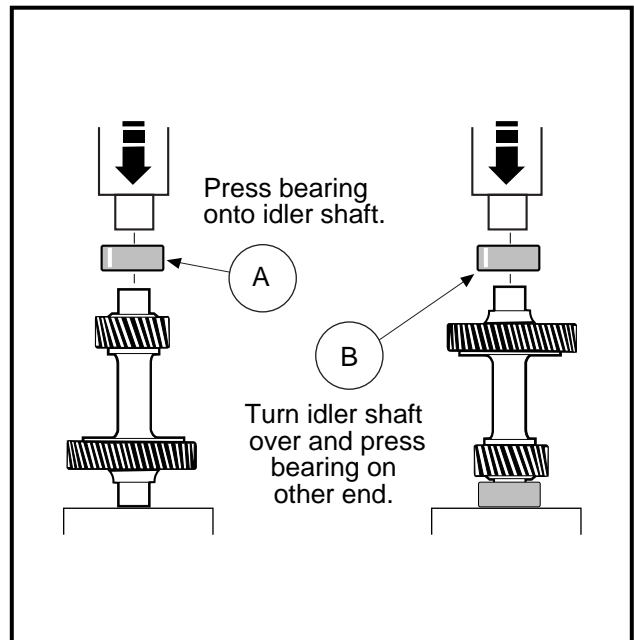

Figure 16-61 Idler Shaft

UNITIZED TRANSAXLE COMPONENT INSPECTION

Read **DANGER** and **WARNING** on page 16-1.

1. Clean all of the component parts of the transaxle in a high flash-point solvent and then dry them. Inspect all components for excessive wear or damage.
2. Inspect all bearings by spinning them by hand. Check the bearings for excessive axial (A) and radial (B) play (**Figure 16-59, Page 16-25**). Replace bearings if they do not spin smoothly, if they are noisy, or if they have excessive play. Replace bearings if they are rusted, worn, cracked, pitted, or discolored.
3. Gears should be inspected for tooth surface damage or fractures.
4. Synchronizer ring teeth should be inspected for severe wear, fractures, or other damage.
5. Using a feeler gauge, measure the distance X at several points around the assembly. The synchro ring should be replaced when X is 0.02 inch (0.5 mm) or less (**Figure 16-60, Page 16-25**).
6. Inspect the O-ring (96) on the differential lock shaft (**Figure 16-47, Page 16-19**).

COMPONENT ASSEMBLY

Read **DANGER** and **WARNING** on page 16-1.

IDLER SHAFT ASSEMBLY

1. Press a new bearing (69) (**Figure 16-48, Page 16-20**) onto each end of the idler shaft (**Figure 16-61, Page 16-25**). See following **CAUTION**.

⚠ CAUTION

- Apply pressure against the inner race of the bearing only. Applying pressure anywhere else will damage the bearing.

INTERMEDIATE GEAR ASSEMBLY

1. If the gear (61) was removed from the shaft, install the key (60) into the slot and then position the gear on the shaft with keyway properly aligned with key. Press gear into place on the key (**Figure 16-48, Page 16-20**).
2. Press the bearing (62) onto the end of the shaft next to the large gear that was installed in step 1 (**Figure 16-48, Page 16-20**). See preceding **CAUTION**.
3. Press a new bearing (41) onto the other end of the shaft (**Figure 16-48, Page 16-20**).

SYNCHRONIZER GEAR ASSEMBLY

1. Press the synchronizer sleeve (50) onto the splines of the input shaft (54) (**Figure 16-48, Page 16-20**). No particular orientation of the sleeve is necessary, but toward the short end of the shaft, the machined circular face surrounding the ends of the internal splines in the sleeve must be flush with the machined lip of the shaft at the ends of the shaft splines (**Figure 16-62, Page 16-27**).

2. Install the synchronizer springs (49) (**Figure 16-48, Page 16-20**) in the sleeve as shown (**Figure 16-63, Page 16-27**).

NOTE: Make sure the ends of the springs are positioned between the synchronizer insert slots (**Figure 16-63, Page 16-27**).

3. Install the three synchronizer inserts (51) into the slots in the sleeve (**Figure 16-48, Page 16-20**). Make sure the notched surfaces of the inserts are facing outward as shown (**Figure 16-64, Page 16-27**).
4. Install the synchronizer clutch hub (52) (**Figure 16-48, Page 16-20**) onto the synchronizer sleeve. Make sure the chamfered end of the hub is oriented toward the long end of the input shaft as shown (**Figure 16-65, Page 16-27**).
5. On the long end of the shaft, install the synchronizer ring (48) (**Figure 16-48, Page 16-20**) with the smooth collar of the ring towards the clutch hub. Make sure the three notches in the collar mate with the synchronizer inserts in the synchronizer sleeve as shown (**Figure 16-66, Page 16-28**).
6. Install the thrust washer (44) and two bearings (46) as shown (**Figure 16-48, Page 16-20**).

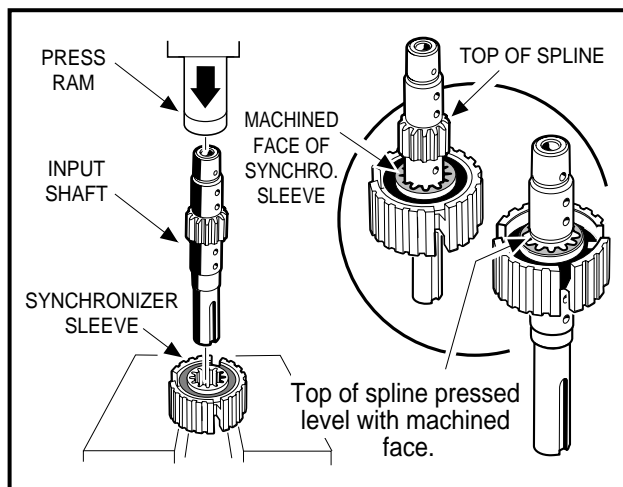

Figure 16-62 Synchro. Gear Assembly

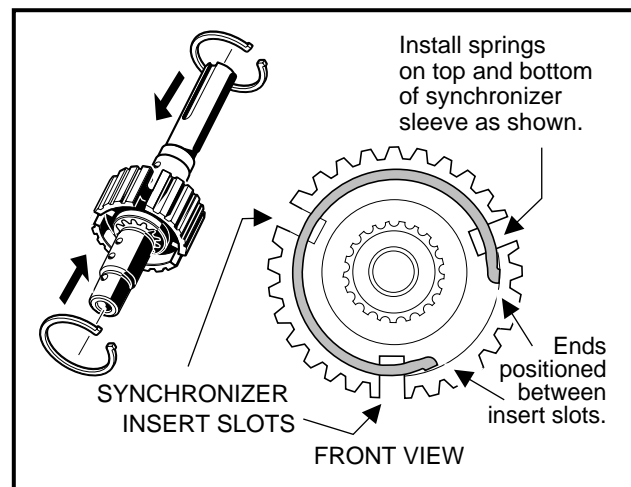

Figure 16-63 Synchro. Springs

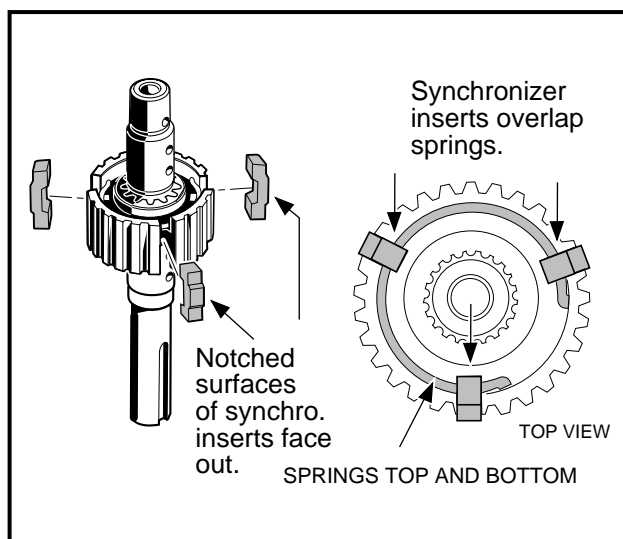

Figure 16-64 Synchronizer Inserts

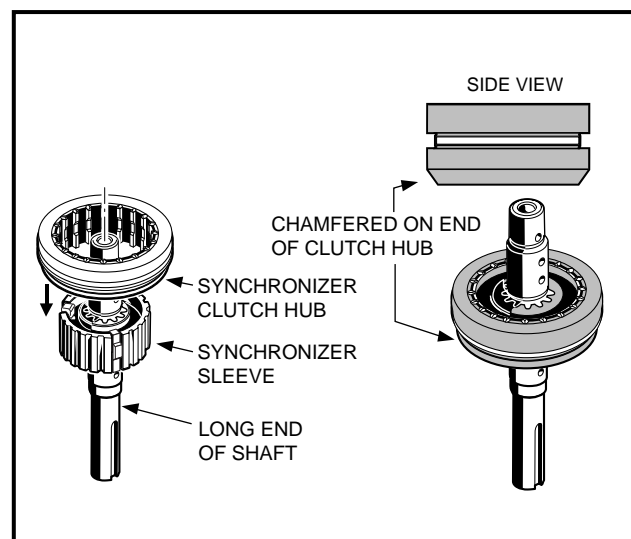

Figure 16-65 Synchronizer Clutch Hub

Synchronizer Gear Assembly, Continued:

7. Install the input gear assembly (55), with the smooth collar toward the synchronizer ring as shown (**Figure 16-48, Page 16-20**). The input gear should seat in the synchronizer ring.
8. Install the thrust washer (56) and then the spring washer (42). The spring washer should be oriented with the raised center toward the end of the shaft (**Figure 16-48, Page 16-20**).
9. Press new bearing (57) (**Figure 16-48, Page 16-20**) onto the shaft until it seats. Make sure the input gear turns freely. **See following CAUTION.**

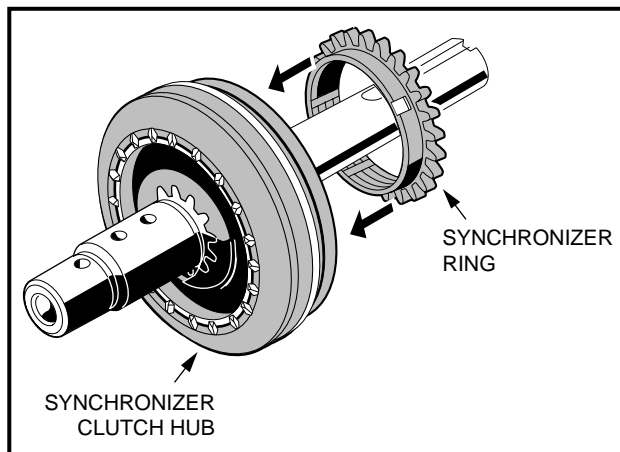

Figure 16-66 Synchronizer Ring

⚠ CAUTION

- Apply pressure against the inner race of the bearing only. Applying pressure anywhere else will damage the bearing.

10. On the other end of the input shaft, install the thrust washer (44), and the synchronizer ring (48). The smooth collar of the synchronizer ring should be oriented toward the clutch hub, and the notches in it should mate with the synchronizer inserts as shown (**Figure 16-48, Page 16-20**).
11. Install the narrow bearing (47), wide bearing (46), and input gear (45) onto the shaft. The smooth collar of the input gear should be oriented toward the synchronizer ring as shown (**Figure 16-48, Page 16-20**). The gear should seat inside the ring.
12. Install thrust plate (44) onto the shaft, and the dowel pin (53) into the shaft as shown (**Figure 16-48, Page 16-20**).
13. Install the spur (governor drive) gear (43) onto the shaft with either side down. Mate the notch in the gear with the dowel pin as shown (**Figure 16-48, Page 16-20**).
14. Install the spring washer (42) onto shaft with the raised center toward the end of the shaft (**Figure 16-48, Page 16-20**).
15. Press a new bearing (41) onto the end of the shaft until it seats (**Figure 16-48, Page 16-20**). Make sure the input gears turn freely. **See following CAUTION.**

⚠ CAUTION

- Apply pressure against the inner race of the bearing only. Applying pressure anywhere else will damage the bearing.

SHIFTER FORK ASSEMBLY

1. Install the spring (38) and ball (39) into the shifter fork (37) as shown (**Figure 16-48, Page 16-20**).
2. Use a No. 1 tip phillips screwdriver to depress the ball and spring while inserting shift rod (36) into the shifter fork (37). Remove screwdriver when the shift rod is inserted far enough for it to depress the ball and spring, then continue to insert rod until the ball is positioned in the middle groove on the rod (**Figure 16-48, Page 16-20**).

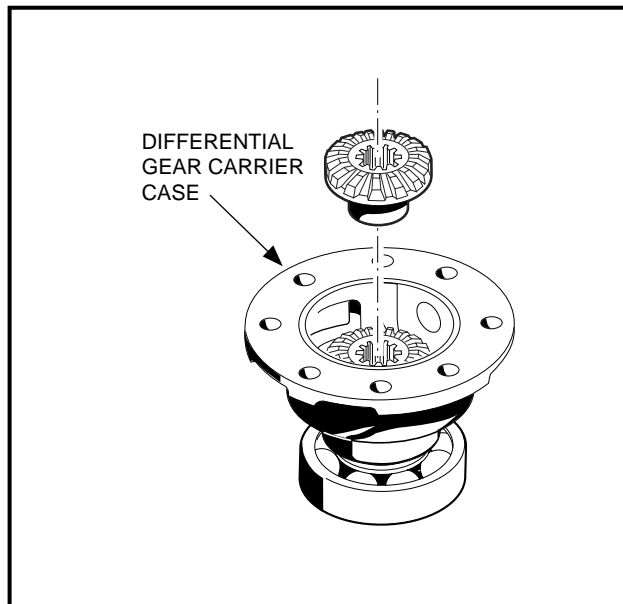

Figure 16-67 Differential Gear

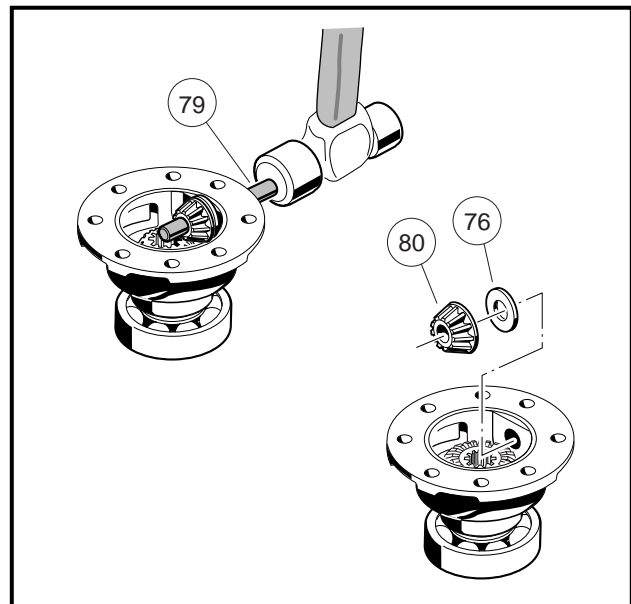

Figure 16-68 Idler Gear

DIFFERENTIAL GEAR CASE ASSEMBLY

1. If the bearings (70 or 71) were removed, press new ones onto the differential gear carrier case (75) and carrier case cover (78) (**Figure 16-48, Page 16-20**). See following **CAUTION**.

▲ CAUTION

- Apply pressure against the inner race of the bearing only. Applying pressure anywhere else will damage the bearing.
2. Install differential gear (82) into carrier case (75) (**Figure 16-48, Page 16-20**) as shown (**Figure 16-67, Page 16-29**).
 3. Start the differential pin (79) into the carrier case by lightly tapping it in with a plastic or rubber hammer. Before the pin enters the inside of the carrier case, position the thrust plate (76) and idler gear (80) in the case and continue tapping the pin through the thrust plate and idler gear as shown (**Figure 16-68, Page 16-29**).
 4. Position the other thrust plate (76) and idler gear (80) in the carrier case. Continue to drive the pin (79) through them and the wall of the carrier case until the ends of the pin are flush with the sides of the carrier case (**Figure 16-69, Page 16-30**).

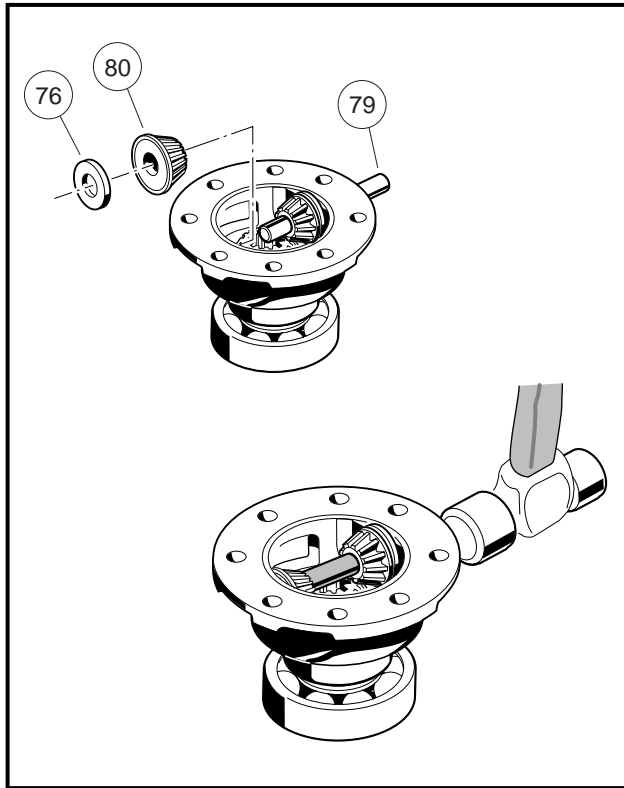

Figure 16-69 Second Idler Gear

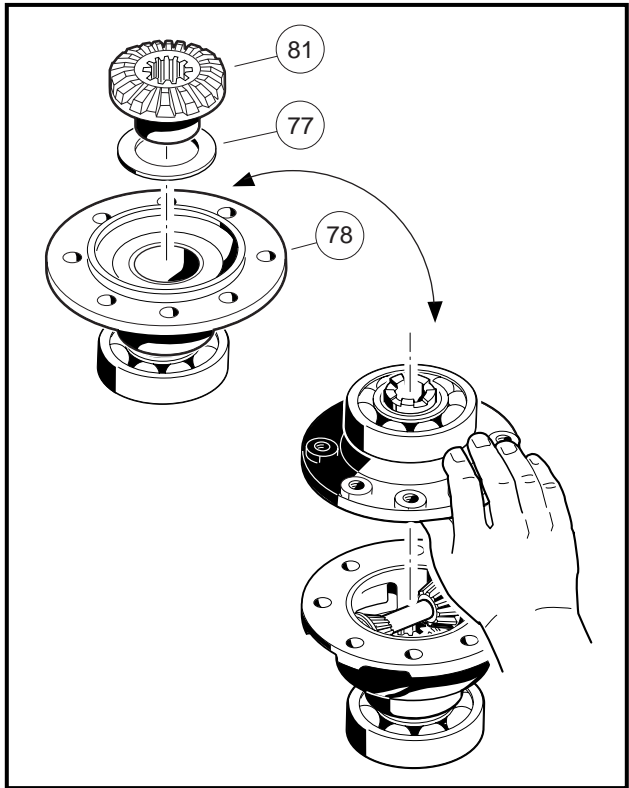

Figure 16-70 Carrier Case

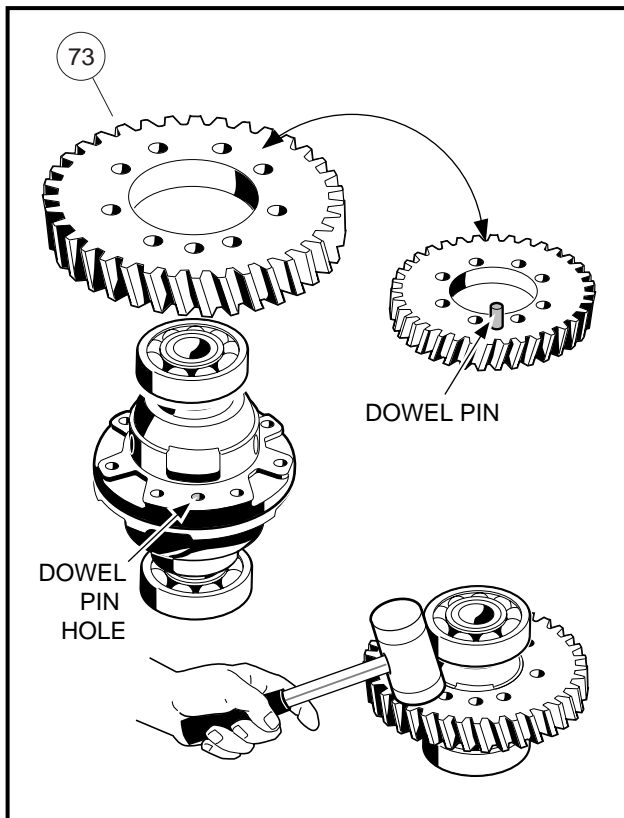

Figure 16-71 Ring Gear

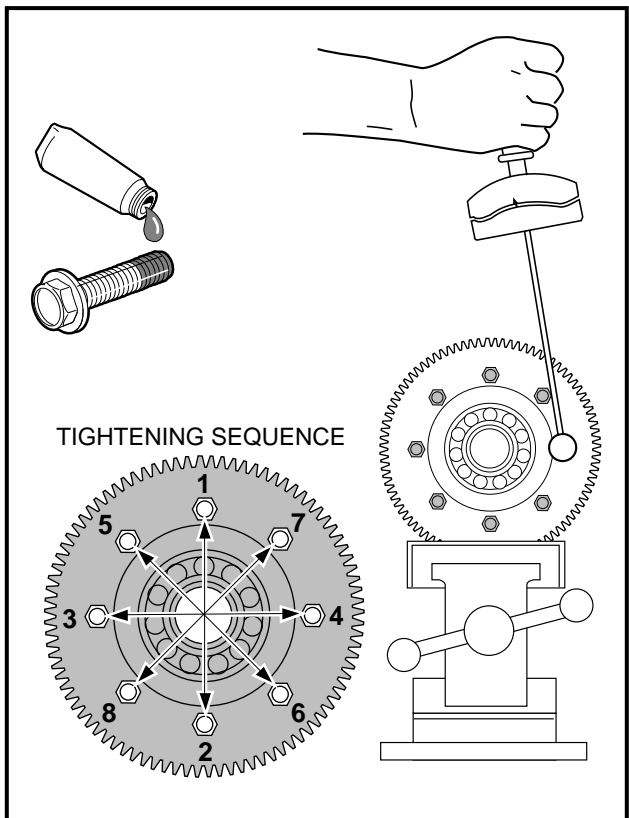

Figure 16-72 Retaining Bolts

Differential Gear Case Assembly, Continued:

5. Install the thrust plate (77) and differential gear (81) into the carrier case cover (78) (**Figure 16-48, Page 16-20**) as shown (**Figure 16-70, Page 16-30**). While holding the thrust plate and differential gear in place, position the carrier case cover on the carrier case (**Figure 16-70, Page 16-30**).
6. Position the output ring gear (73) (**Figure 16-48, Page 16-20**) on the carrier case, visually aligning the dowel hole in the carrier case with the dowel pin in the ring gear. Using a plastic or rubber mallet, tap the ring gear into place on the dowel pin as shown (**Figure 16-71, Page 16-30**).
7. Apply Loctite 277 on the threads of the eight mounting bolts and install them through the ring gear, carrier case, and into the carrier case cover. Tighten the bolts to 18 ft-lb (24.4 N·m) in the sequence shown (**Figure 16-72, Page 16-30**).

GOVERNOR GEAR ASSEMBLY

The governor gear is not assembled before installing it in the unitized transaxle case. The governor gear shaft is installed into the case and then the rest of the governor gear assembly is installed on the shaft. Proceed with unitized transaxle assembly.

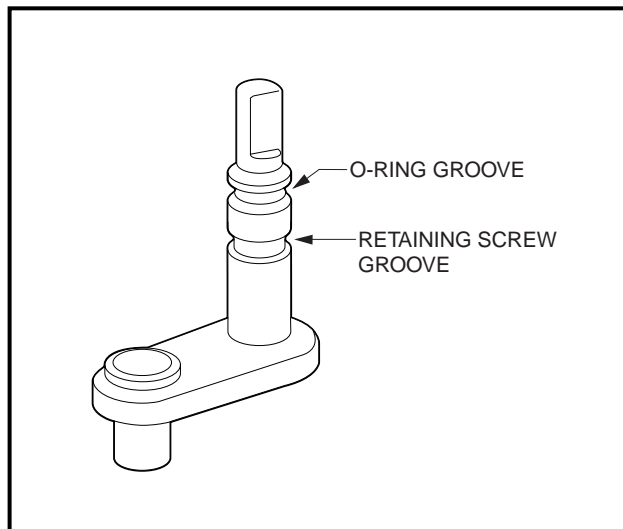

Figure 16-73 Differential Lock Shaft

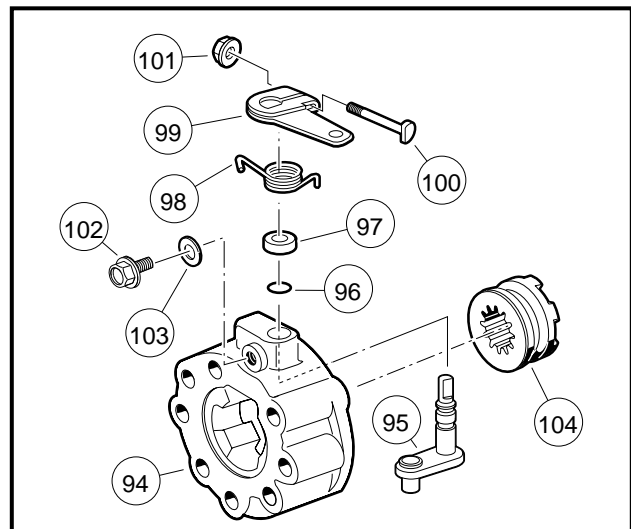

Figure 16-74 Differential Lock Housing Assembly

DIFFERENTIAL GEAR LOCK HOUSING ASSEMBLY

1. If previously removed, slide the O-Ring into the top groove of the differential lock shaft (**Figure 16-73, Page 16-31**).
2. Place the shaft (95) into the hole in the differential lock housing (94) (**Figure 16-74, Page 16-31**).
3. Install the retaining screw (102) and washer (103) into the differential lock housing. Ensure that the screw is aligned with the second groove in the differential lock shaft before continuing to tighten the screw (**Figure 16-74, Page 16-31**). Tighten the screw to 69 in-lb (7.8 N·m).
4. Place the spacer (97) onto the differential lock shaft (**Figure 16-74, Page 16-31**).
5. Install the spring over the spacer so that the straight end of the spring will rest on the axle tube side of the differential lock housing (**Figure 16-74, Page 16-31**).
6. Place the differential lock arm (99) on the shaft (95) and place the hooked end of the spring (98) on the arm (**Figure 16-74, Page 16-31**).
7. Tighten the differential lock arm retainer nut (101) to 60 in-lb (6.8 N·m) (**Figure 16-74, Page 16-31**).

UNITIZED TRANSAXLE ASSEMBLY

Read **DANGER** and **WARNING** on page 16-1.

NOTE: Although the following drawings show the transaxle being assembled in an upright position, laying the transaxle on its left (driver) side will simplify the assembly process.

1. Make sure both parts of the case are clean and free of any contaminants. Make sure the machined mating surfaces are free of residue and are not scratched or damaged in any way.
2. Put a light coating of clean transmission oil on the outside edge of the seal to make installation easier. Press two new oil seals (18 and 23) (**Figure 16-40, Page 16-16**) into the left (driver) side case. Use an oil seal installation tool (CCI 1014160) to install a new oil seal (58) (**Figure 16-48, Page 16-20**) into the right (passenger side) case. **See also Figure 16-75, Page 16-32.**
3. Position the governor gear shaft installation tool (CCI 101933101) over the shaft bore in the inside of the left (driver) side case and insert the governor gear shaft into the tool, long end (from the groove) first, as shown (**Figure 16-76, Page 16-32**). Make sure the shaft is started into the bore and then, using a plastic or rubber hammer, carefully tap the governor gear shaft into the bore until the end being tapped is flush with the end of the tool. Remove installation tool.
4. Install the washer, governor gear, and sleeve together onto the governor shaft (**Figure 16-77, Page 16-33**). Make sure the sleeve is properly positioned within the flyweight brackets of the gear as shown (**Figure 16-78, Page 16-33**), and then push them onto the shaft until the gear snaps into the groove on the shaft.
5. Position the interior washer on the pivot arm, then install the pivot arm and washer into the left (driver) side case as shown (**Figure 16-79, Page 16-33**). Install the exterior washer and cotter pin on the pivot arm outside the case as shown (**Figure 16-79, Page 16-33**). Bend the legs of the cotter pin.

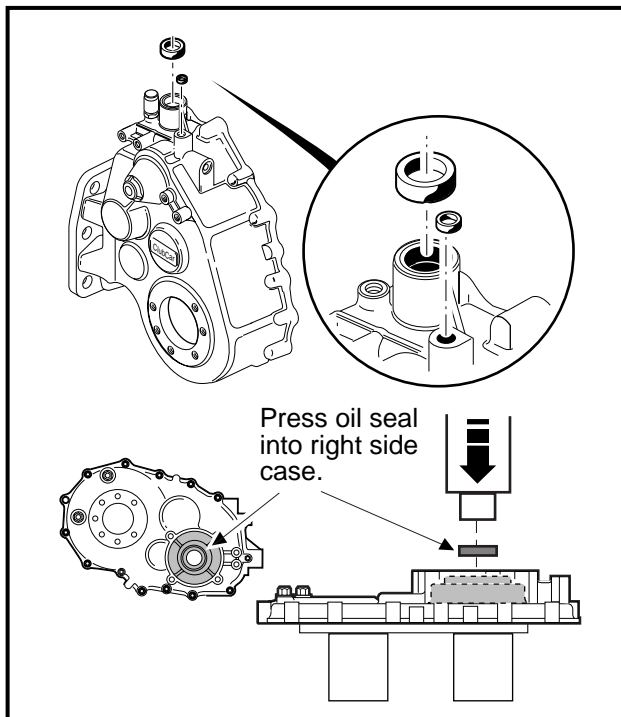

Figure 16-75 Install Seals

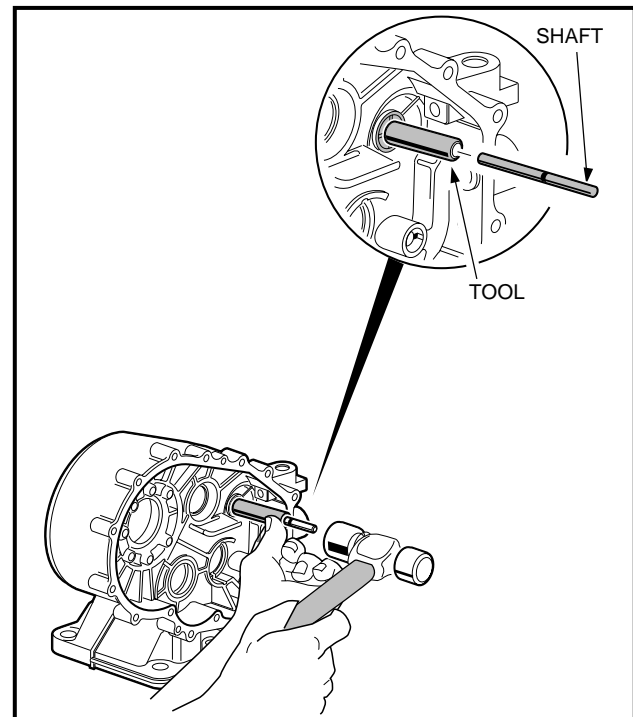

Figure 16-76 Governor Gear Shaft

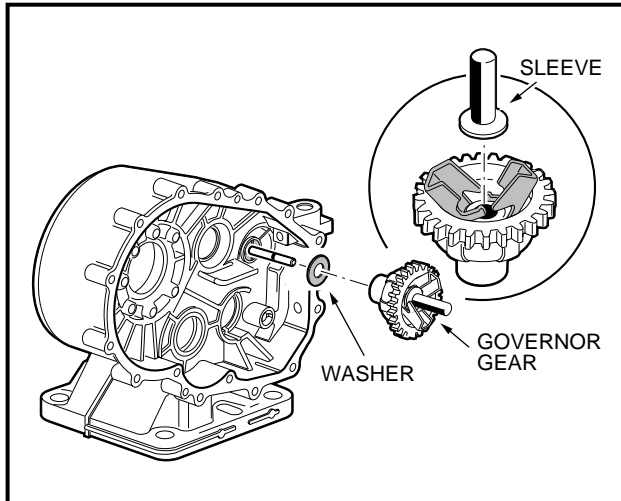

Figure 16-77 Position Governor Gear

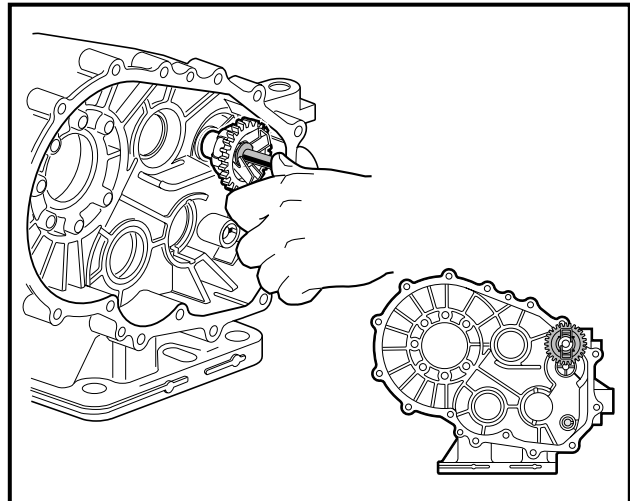

Figure 16-78 Install Governor Gear

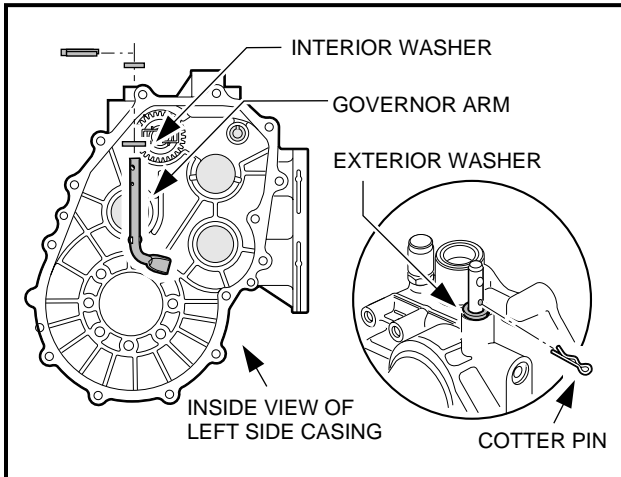

Figure 16-79 Pivot Arm

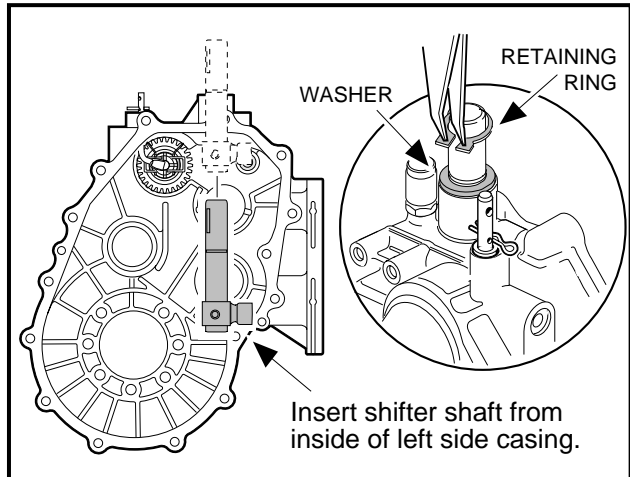

Figure 16-80 Insert Shifter Shaft

6. Install the shifter shaft into the left (driver side) case as shown (**Figure 16-80, Page 16-33**). Then install the washer and using external snap ring pliers (.070 tip), install retaining ring on the shifter shaft outside of the case (**Figure 16-80, Page 16-33**). Make sure the retaining ring is in the groove of the shaft.
7. Install the gear assemblies into the left (driver side) case.
 - 7.1. Stand the left side case on the mounting plate, then install the differential gear case assembly as shown (**Figure 16-81, Page 16-34**). Do not seat the assembly in the bore, but insert it just far enough that it will not fall out.
 - 7.2. Install the idler gear assembly into case as shown. Do not seat the assembly in the bore, but insert far enough that it will not fall out. No gears mesh at this time (**Figure 16-82, Page 16-34**).
 - 7.3. Install the oil guide with the baffle toward the case wall as shown (**Figure 16-83, Page 16-34**). Make sure the two tabs on the guide are positioned in the slots in the case.
 - 7.4. Position the shifter fork assembly on the synchronizer gear assembly as shown, and install them together, bearing end first, into the bore containing the oil guide (**Figure 16-84, Page 16-34**). Do not seat the assembly, but make sure the spur gear (43) is meshed with the governor gear (66) (**Figure 16-48, Page 16-20**), and the shifter lever (19) (**Figure 16-40, Page 16-16**) is positioned in the bracket on the shifter fork. **See also Figure 16-85, Page 16-36.**

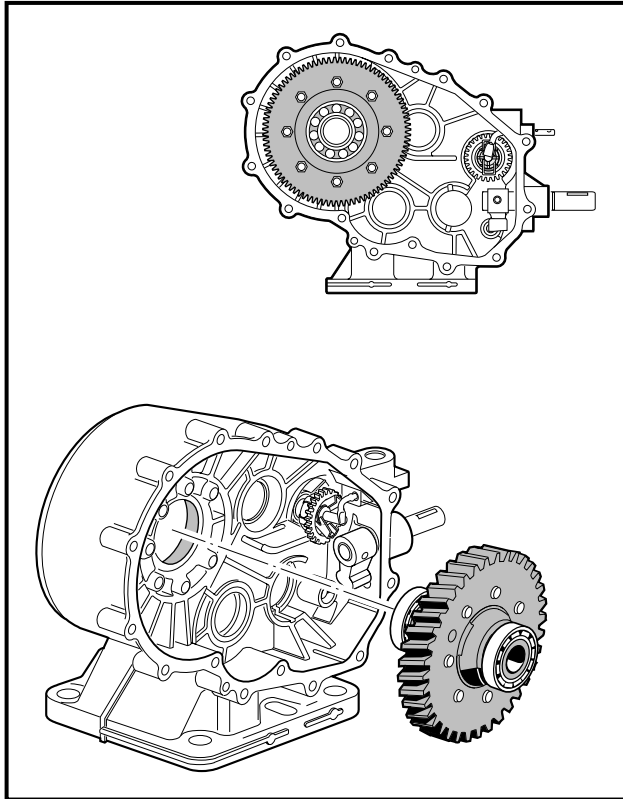

Figure 16-81 Differential Gear Assembly

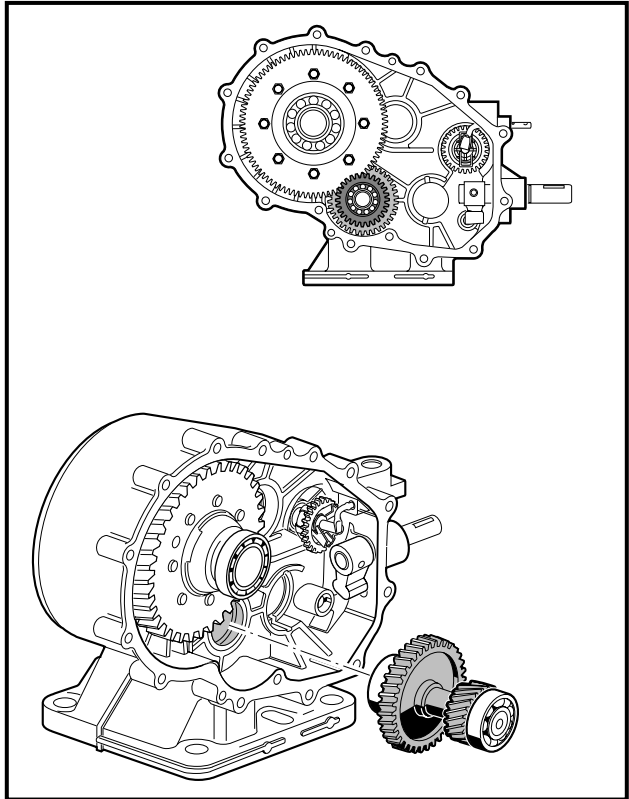

Figure 16-82 Idler Gear Assembly

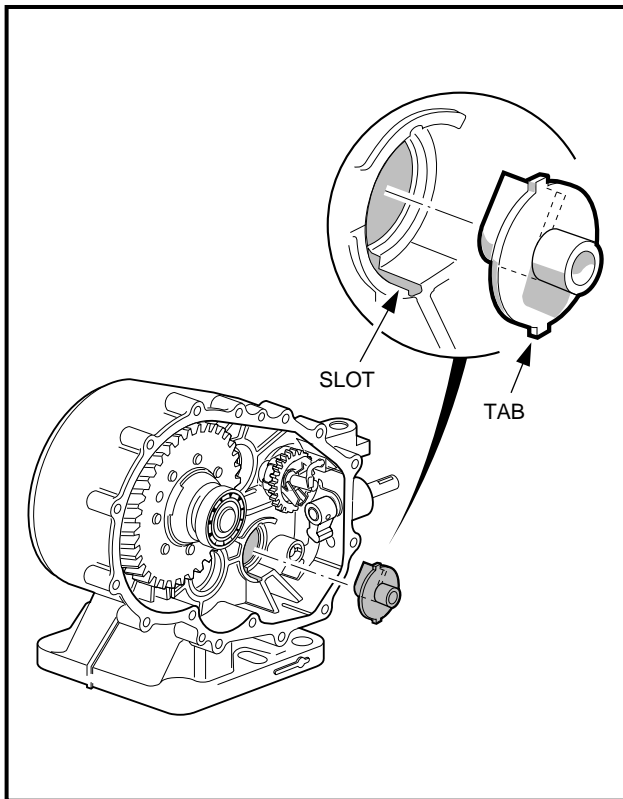

Figure 16-83 Oil Guide

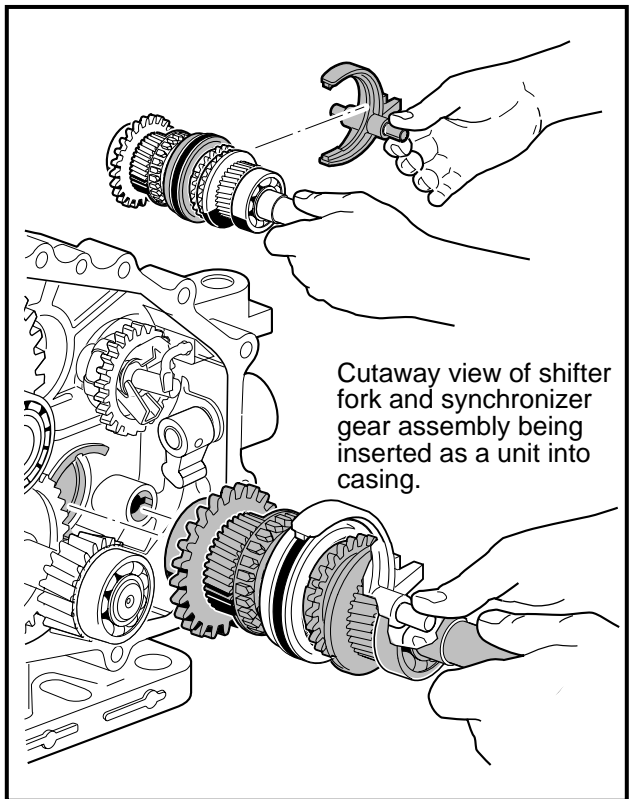

Figure 16-84 Synchronizer Ring Gear

Unitized Transaxle Assembly, Continued:

- 7.5. Install the intermediate gear assembly into the case as shown (**Figure 16-86, Page 16-36**). Do not seat the assembly into the bore, but make sure the output ring gear meshes with the input drive gear (55) on the synchronizer gear assembly, and with the small gear on the idler shaft (68) (**Figure 16-48, Page 16-20**).
- 7.6. As a group and while keeping the gears meshed, work all of the gear assemblies into the bores until they are seated. When all of the assemblies are correctly seated, the outside edges of the input drive gear (55) and the intermediate gear (61) (**Figure 16-48, Page 16-20**) should be flush (in the same plane) as shown (**Figure 16-87, Page 16-36**). Also, the outside surfaces of the idler gear bearing, the intermediate gear bearing, and the differential gear bearing should be flush (**Figure 16-87, Page 16-36**). **See following CAUTION.**

▲ CAUTION

- *If the edges of the input drive gear and intermediate gear are not flush, then the oil guide (40) (**Figure 16-48, Page 16-20**) may not be properly positioned in the bore.*
8. Make sure the mating surfaces of the left and right sides of the case are clean and free of oil, grease, or residue of any kind, and they are not scratched or damaged in any way.
 9. Apply a continuous bead of Three Bond No. 1215 (CCI 101928701) sealant to the mating surface, around the complete profile of the right (passenger side) case (**Figure 16-88, Page 16-36**). **See following CAUTION.**

▲ CAUTION

- *Use only Three Bond No. 1215 sealant to seal case. Do not use a substitute.*
 - *If the two sides of the case cannot be easily closed or do not make complete contact, do not force them together. Check that all internal components are properly seated and then try again.*
10. Install and finger tighten the fifteen bolts (28) (**Figure 16-40, Page 16-16**) that secure the left and right sides of the case together. Then, in sequence shown, tighten the bolts to 17 ft-lb (23.1 N·m) (**Figure 16-89, Page 16-37**).
 11. Install the differential lock housing to the transaxle.
 - 11.1. Make sure the mating surfaces of the differential lock housing and the transaxle case are clean and free of oil, grease or residue of any kind.
 - 11.2. Ensure that the alignment pin is installed to the transaxle case (**Figure 16-90, Page 16-37**).
 - 11.3. Apply a continuous bead of Three Bond No. 1215 (CCI 101928701) around the opening on the mating surface of the differential lock housing (transaxle side) (**Figure 16-90, Page 16-37**).
 - 11.4. Rotate the differential lock shaft (95) and insert the cog (104) into the differential lock housing (94) (**Figure 16-74, Page 16-31**).
 - 11.5. Using the alignment pin as a guide, position the differential lock housing onto the driver side of the transaxle case (**Figure 16-90, Page 16-37**).

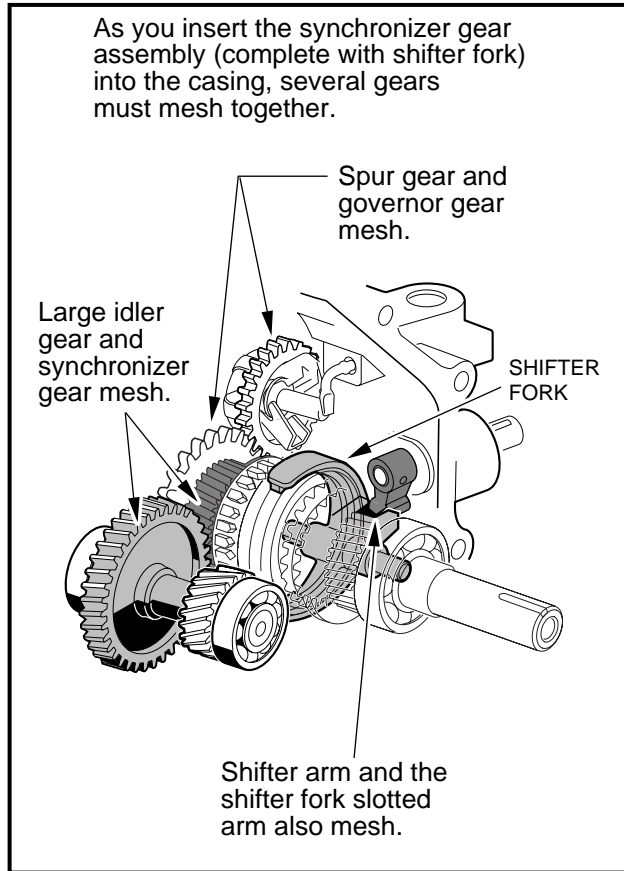

Figure 16-85 Gear Alignment

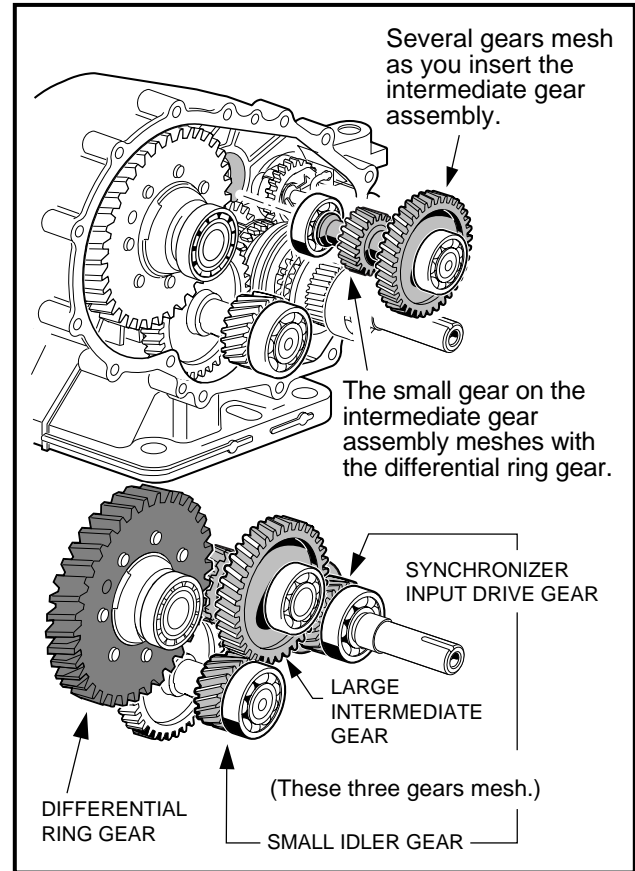

Figure 16-86 Gear Alignment

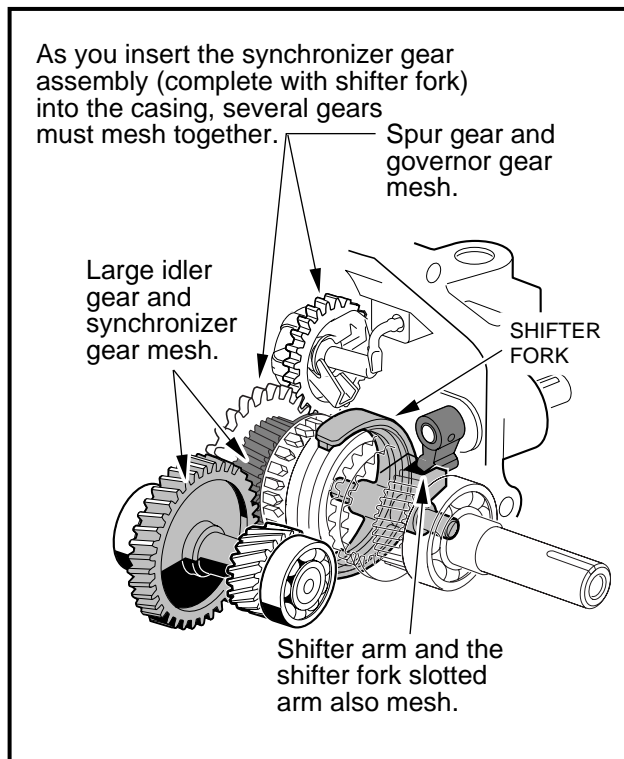

Figure 16-87 Gear Alignment

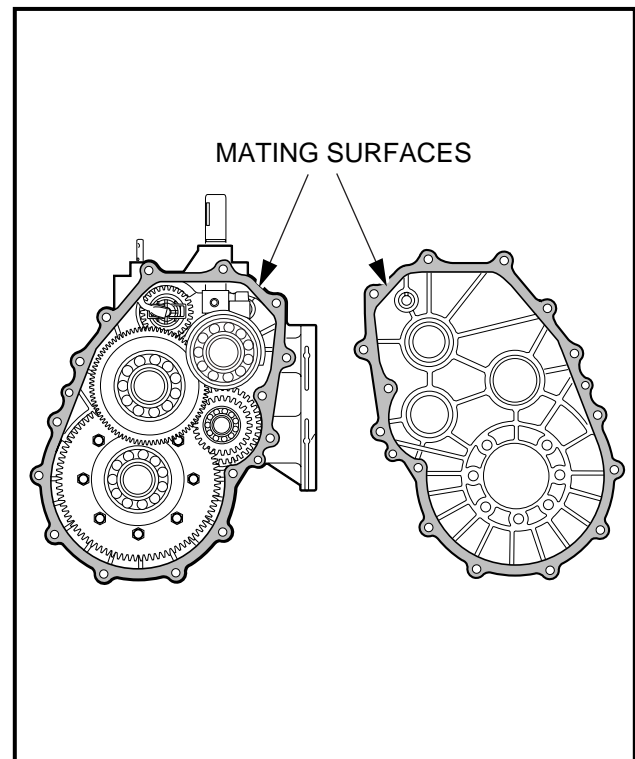

Figure 16-88 Prepare Mating Surfaces

Unitized Transaxle Assembly, Continued:

12. Install axle tubes (90 and 91) and brake cluster assemblies (if removed) on the transaxle case (**Figure 16-4, Page 16-4**).

12.1. Make sure the mating surfaces of the axle tubes, transaxle case, and differential lock housing are clean and free of oil, grease, or residue of any kind.

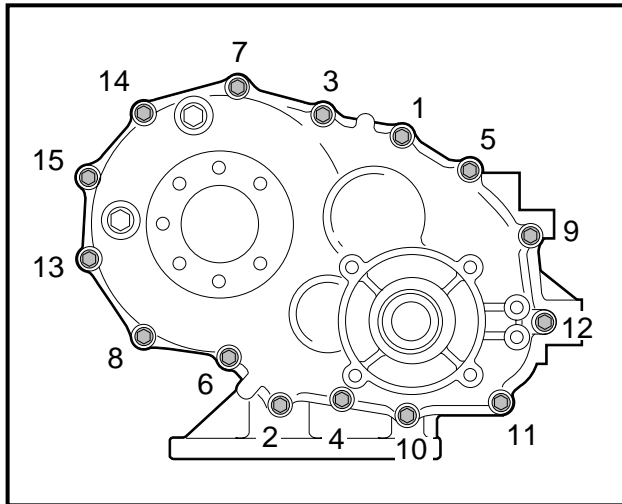

Figure 16-89 Casing Torque Sequence

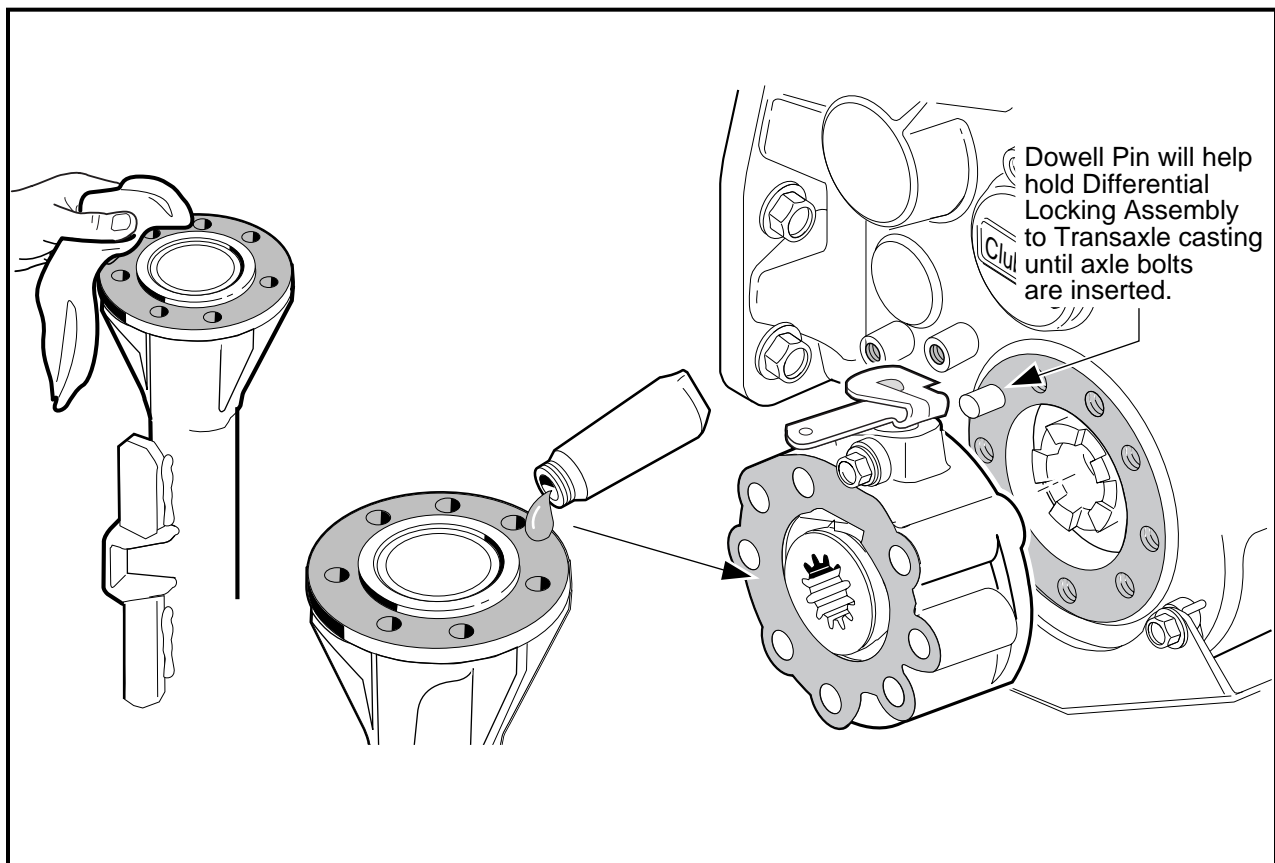

Figure 16-90 Axle Tube Surface

Unitized Transaxle Assembly, Continued:

- 12.2. Apply a continuous bead of Three Bond No. 1215 (CCI 101928701) around the opening on the mating surface of the left (driver) side axle tube as shown (**Figure 16-90, Page 16-37**). Then position the axle tube on the left side of the transaxle case to the differential lock housing as shown and install seven mounting bolts (92) (**Figure 16-4, Page 16-4**) finger tight. In the sequence shown, tighten the bolts to 36 ft-lb (48.8 N·m) (**Figure 16-91, Page 16-38**).
- 12.3. Duplicate step 12.2 for installing the right (passenger) side axle tube directly to the transaxle case.
- 12.4. If previously removed, install left and right brake cluster assemblies to the axle tubes. **See Section 6 – Hydraulic and Park Brake Systems.**
- 12.5. Install the right (passenger side) axle shaft (83) in the right axle tube (91) (**Figure 16-4, Page 16-4**). Using 90° angle (.90 tip) snap ring pliers, install the retaining ring as shown (**Figure 16-92, Page 16-38**).
- 12.6. Place a 1/4 to 3/8 inch (6-10 mm) diameter rod against the retaining ring and tap lightly at four to five locations to ensure it is properly seated. **See following WARNING.**

⚠ WARNING

- **Be sure retaining ring is properly seated in its groove. If ring is not properly installed, the axle assembly will separate from the transaxle and damage the axle assembly and other components. Loss of vehicle control could result in severe personal injury or death.**
- 12.7. Install the left (driver side) axle shaft (82) in the left axle tube (90) (**Figure 16-4, Page 16-4**). Using 90° angle (.090 tip) snap ring pliers, install the retaining ring as shown (**Figure 16-92, Page 16-38**).
 - 12.8. Place a 1/4 to 3/8 inch (6-10 mm) diameter rod against the retaining ring and tap lightly at four to five locations to ensure it is properly seated. **See preceding WARNING.**
13. If previously removed, install the park brake cable support brackets on the axle tubes:
 - 13.1. Place the bracket on the axle tube as shown (**Figure 16-23, Page 16-11**).
 - 13.2. Install the bolt (17), washers, and lock nut on the bracket and tighten to 23 ft-lb (31.2 N·m) (**Figure 16-23, Page 16-11**).

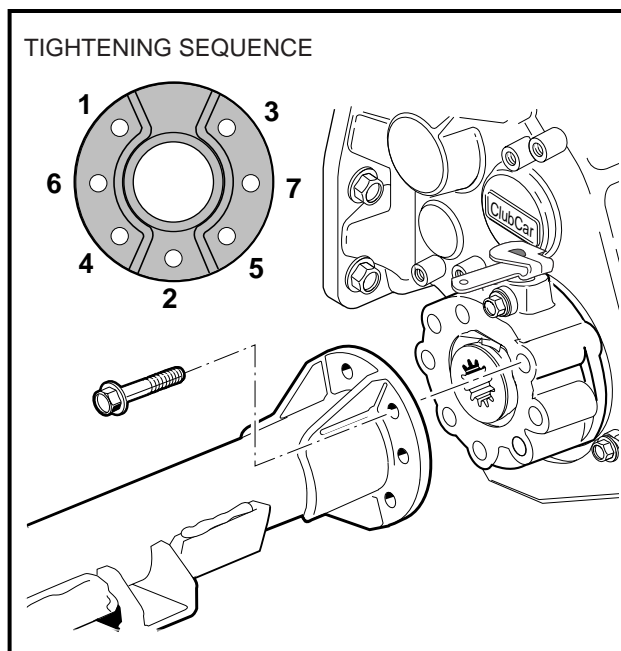

Figure 16-91 Install Axle Tubes

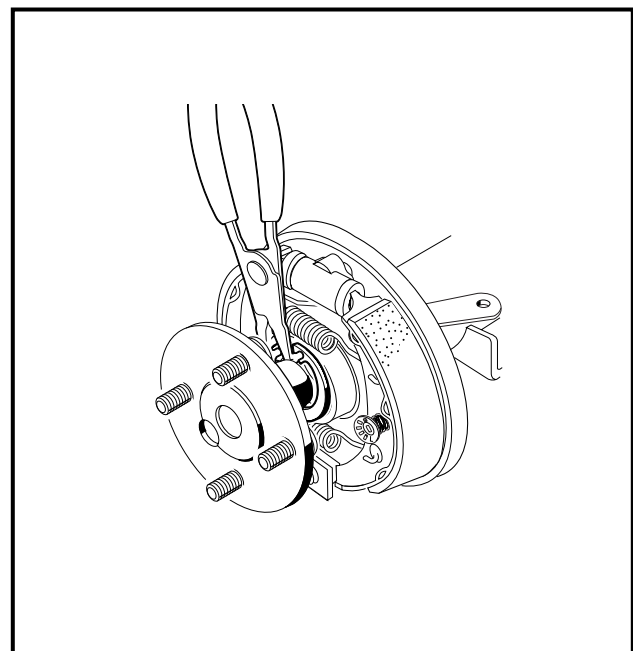

Figure 16-92 Retaining Ring

UNITIZED TRANSAXLE INSTALLATION

Read **DANGER** and **WARNING** on page 16-1.

1. Install the wheels. **See Section 8 – Wheels and Tires.**
2. Install the leaf springs. **See Section 9 – Rear Suspension.**
3. Position the transaxle mounting plate on the two mounting studs at the rear of the engine, and then install the two mounting nuts (**Figure 16-93, Page 16-39**).
4. Install the remaining four mounting bolts and four nuts (one bolt and nut at each corner of the mounting plate).
5. Tighten the four corner nuts (with bolts) to 30 ft-lb (40.7 N-m). Tighten the two center nuts (on the studs) to 17 ft-lb (23.1 N-m) (**Figure 16-93, Page 16-39**).
6. Install the differential lock cable and bracket.
 - 6.1. Connect the differential lock cable spring (1) to the differential lock arm on the differential lock housing (**Figure 16-94, Page 16-39**).
 - 6.2. Install the two bolts (2) to secure the cable bracket to the transaxle case (**Figure 16-94, Page 16-39**). Tighten the two screws to 134 in-lb (15.1 N-m).
7. Install the accelerator cable bracket on transaxle case. Tighten the mounting screws to 134 in-lb (15.1 N-m) (**Figure 16-95, Page 16-40**).
8. Install the governor cable bracket on transaxle case. Tighten the mounting screws to 134 in-lb (15.1 N-m) (**Figure 16-96, Page 16-40**).
9. Install governor lever arm on governor shaft (**Figure 16-97, Page 16-40**). With the governor lever arm loose on the governor shaft, turn the governor arm shaft counterclockwise until it stops. Then pull the governor lever arm rearward until the carburetor throttle is in the “wide open throttle” (WOT) position (**Figure 16-97, Page 16-40**).

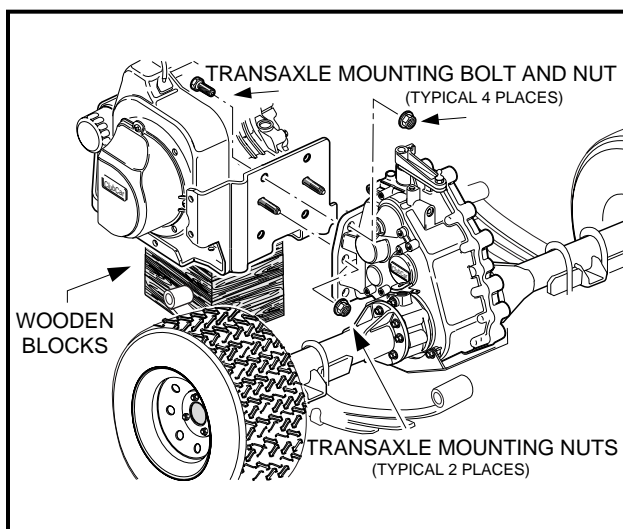

Figure 16-93 Transaxle Mounting

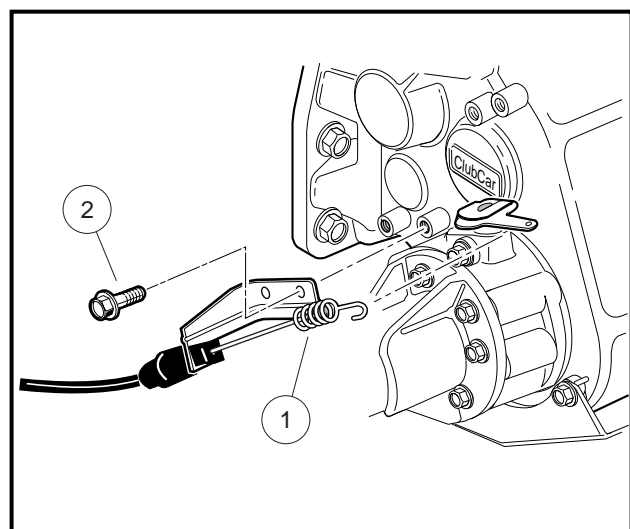

Figure 16-94 Differential Lock Bracket Installation

Unitized Transaxle Installation, Continued:

10. While holding the arm and shaft in the fully counterclockwise position, tighten the governor arm lever nut to 35 in-lb (4.0 N·m) (**Figure 16-97, Page 16-40**).
11. Install the key onto the input shaft (**Figure 16-98, Page 16-41**).
12. Position the driven clutch on the transaxle input shaft and install the washer (yellow side facing out) and mounting bolt. Tighten the mounting bolt to 14 ft-lb (19.0 N·m) (**Figure 16-98, Page 16-41**).
13. Install the drive belt. **See Section 17 – Torque Converter.**
14. Remove the blocks from under the engine and roll the powertrain into position under the vehicle. Then lift the front of the powertrain and place the snubber into the snubber bracket in the vehicle frame (**Figure 16-99, Page 16-41**).
15. With the floor jack under the transaxle, position the leaf springs in the front spring mounts and install the **grade eight** bolts and locknuts. Tighten to 15 ft-lb (20.3 N·m) (**Figure 16-100, Page 16-41**).

⚠ CAUTION

- Use only grade eight bolts for the front mounts of the leaf springs.

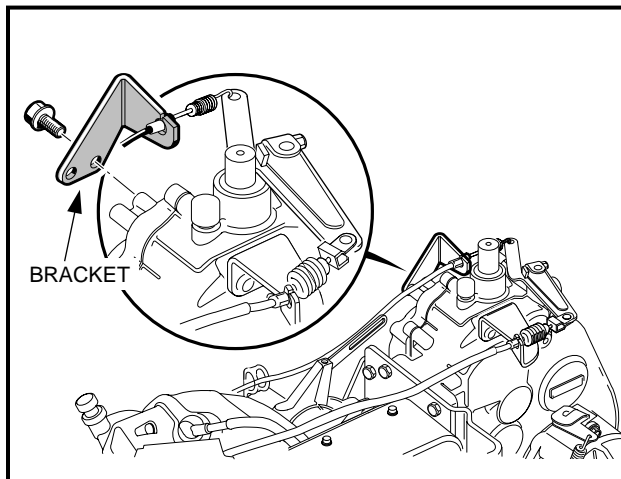

Figure 16-95 Accelerator Cable Bracket

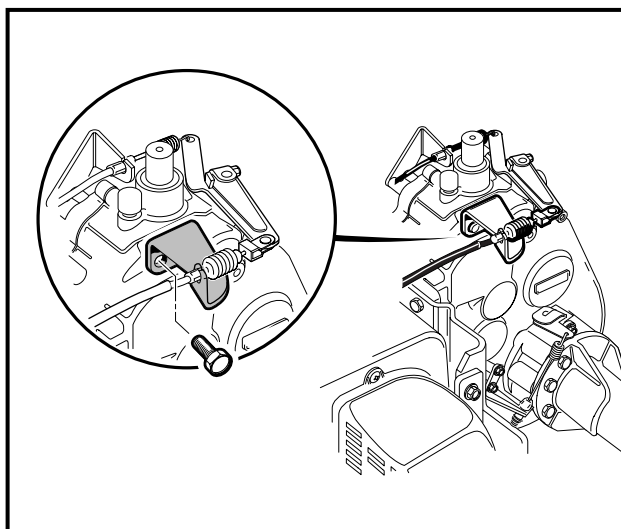

Figure 16-96 Governor Cable Bracket

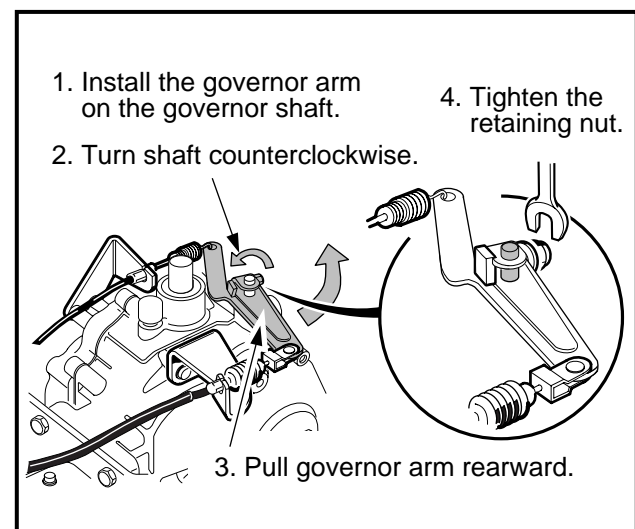

Figure 16-97 Governor Arm

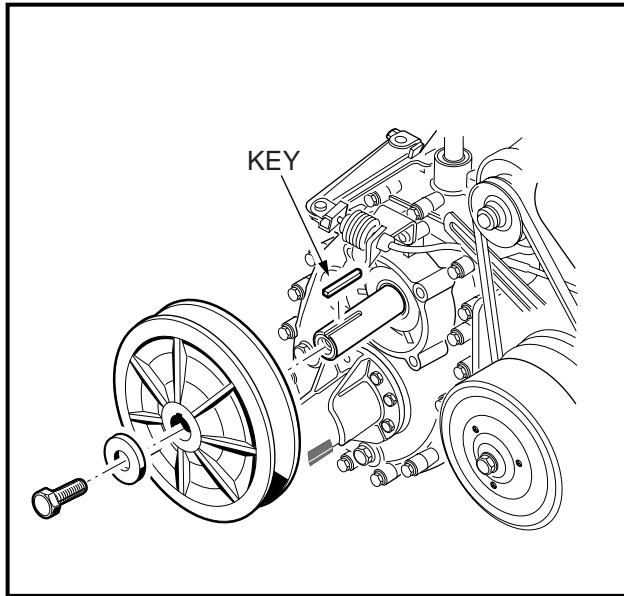

Figure 16-98 Driven Clutch

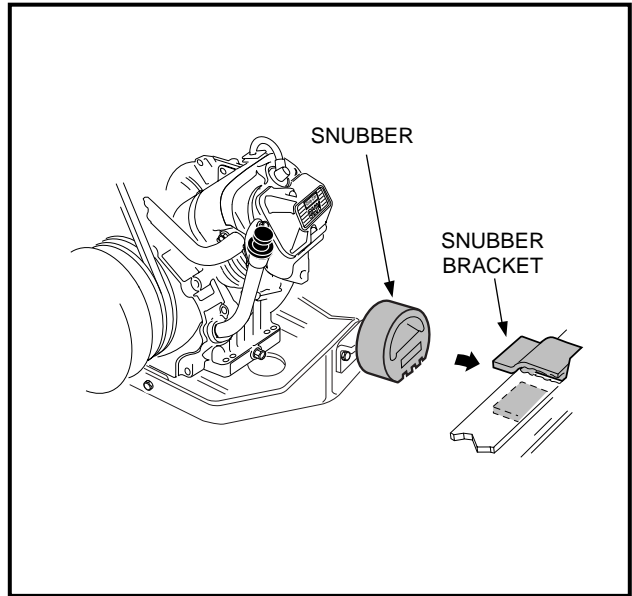

Figure 16-99 Snubber

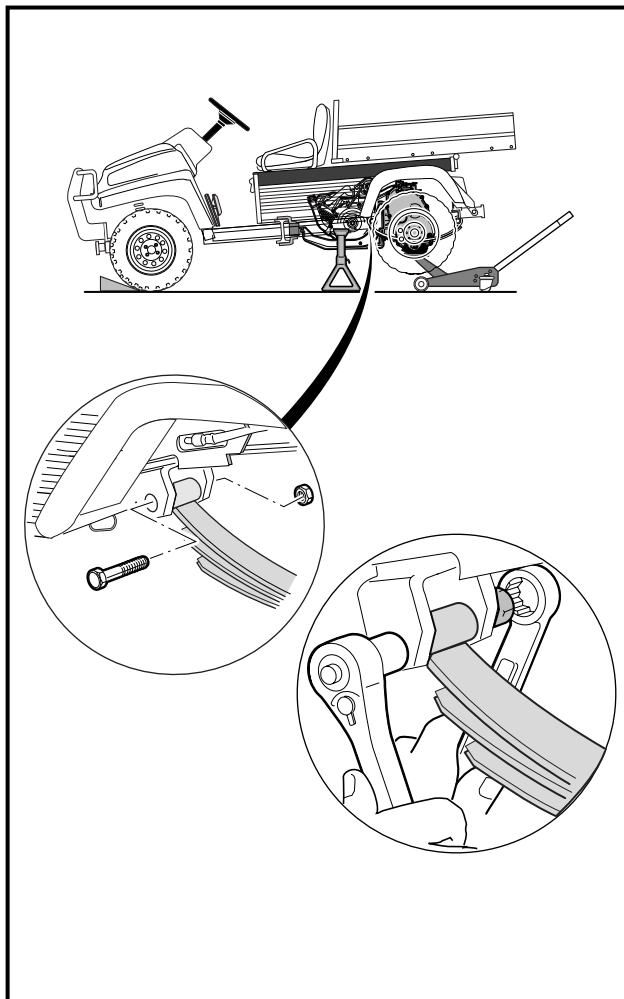

Figure 16-100 Leaf Springs

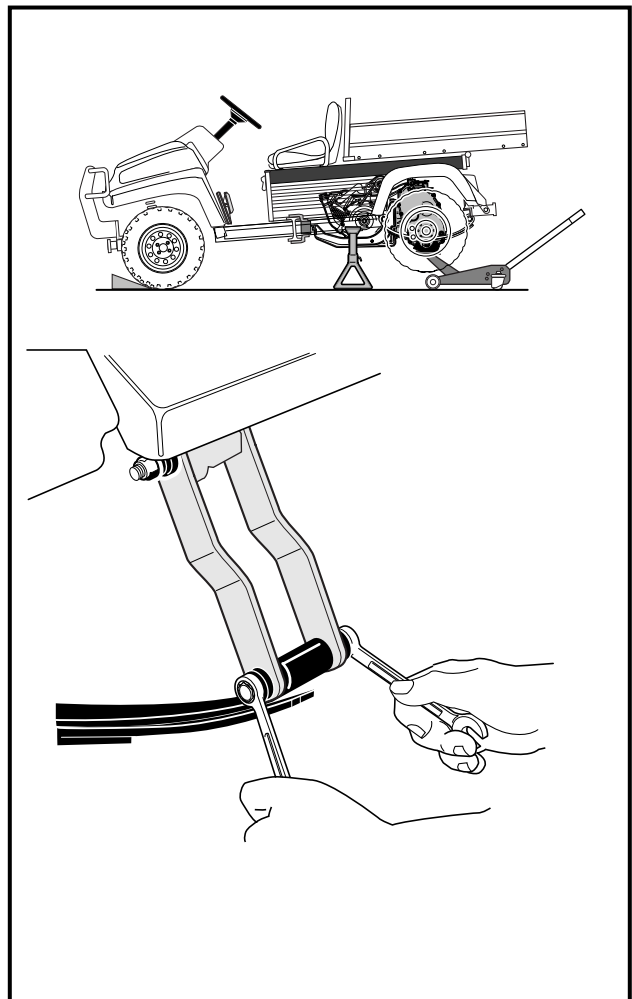

Figure 16-101 Leaf Springs and Shackles

Unitized Transaxle Installation, Continued:

16. Again, using the floor jack, adjust vehicle height to position the leaf springs for mounting in the shackles. Install the mounting bolts, and locknuts (**Figure 16-101, Page 16-41**). Tighten to 15 ft-lb (20.3 N·m).
17. Raise the vehicle with the floor jack and remove the jack stands. With the jack stands removed, gently lower the vehicle.
18. Position shocks in the shock mounts and install cushions, mounting washers, and nuts (**Figure 16-102, Page 16-42**). Tighten nuts until cushions expand to be the same diameter as the mounting washers.
19. Connect the park brake cables. **See Section 6 – Hydraulic and Park Brake Systems.**
20. Using a **flare nut wrench**, connect the brake hoses to the left rear and right rear brake clusters and bleed the air from the brake lines. **See Section 6 – Hydraulic and Park Brake Systems.**
21. Check the brake system to ensure that there are no leaks and that proper brake operation has been restored. **See following WARNING.**

⚠ WARNING

- **The brakes must be bled after the correct reinstallation of the brake components. Failure to bleed the brakes could result in decreased braking performance due to air being trapped in the hydraulic system. See Bleeding the Hydraulic Brake System on page 6-29.**
22. Connect the engine kill switch wire (18 gauge white/black) to the bullet connector at the lower right front of the engine (**Figure 16-103, Page 16-43**).
 23. Install three wire ties to secure the engine kill wire to the accelerator cable where they both route together on the passenger side of the engine.
 24. Connect the oil level sensor wire (18 gauge yellow) to the jumper wire (**Figure 16-104, Page 16-43**).

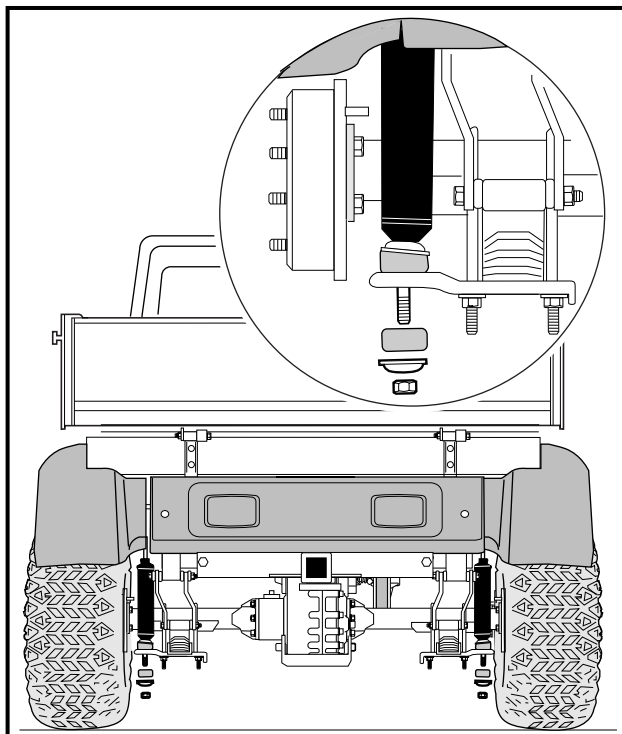
**Figure 16-102 Shock Absorber**

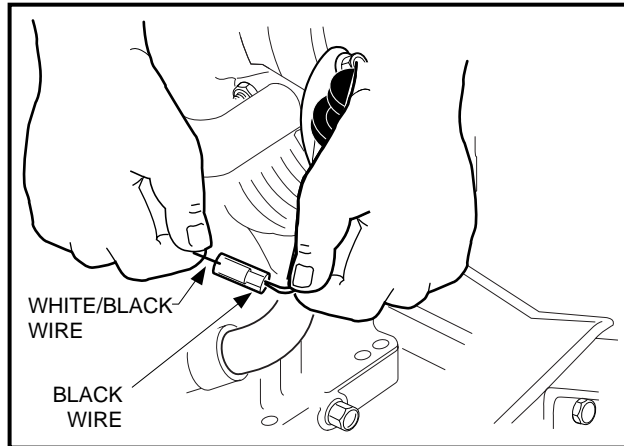

Figure 16-103 Ignition Kill Wire

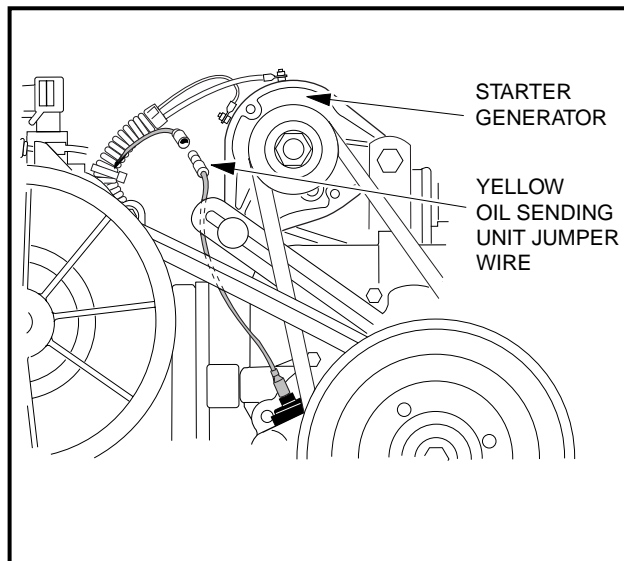

Figure 16-104 Oil Level Sensor Jumper Wire

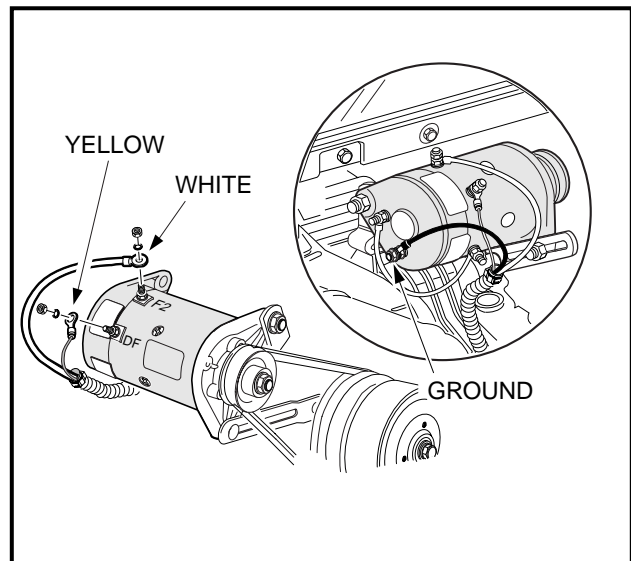
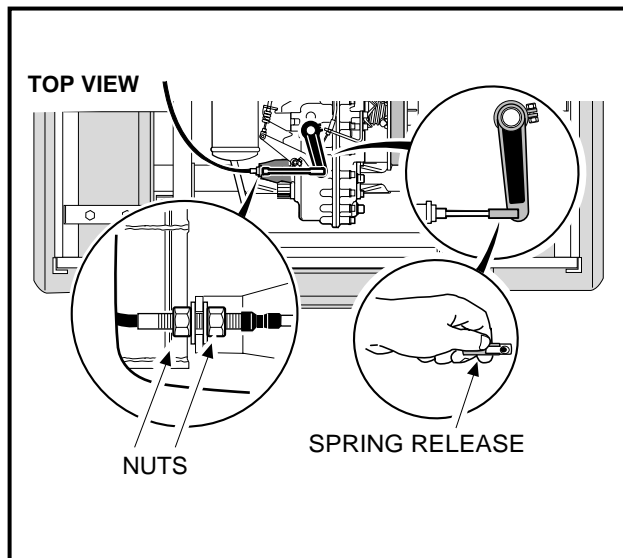
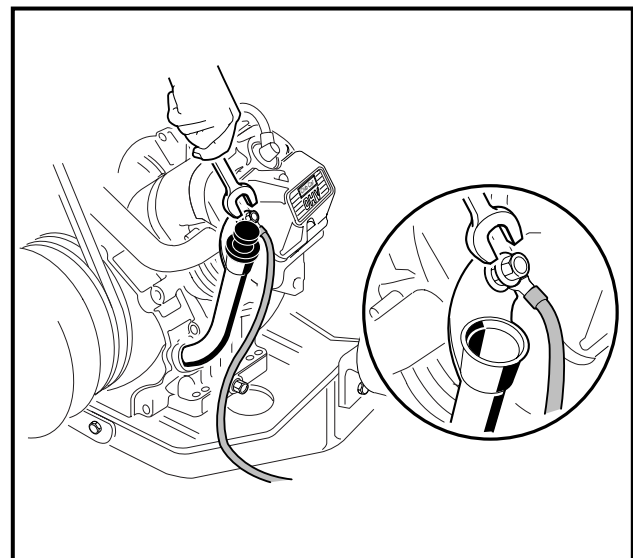
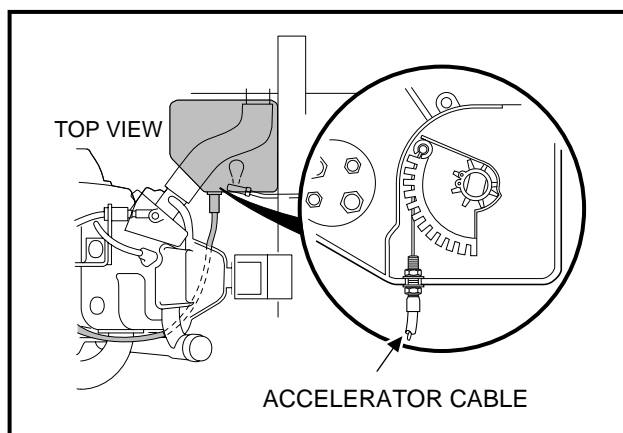
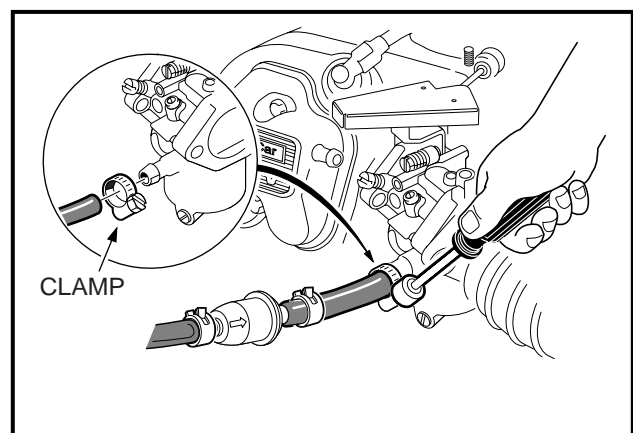

Figure 16-105 Starter/Generator

25. Connect the 6 gauge white wire to the F2 post, the 6 gauge black ground wire to the A2 post and tighten to 48 in-lb (5.4 N-m). Connect the 16 gauge yellow wire to the DF post on the starter/generator and tighten to 30 in-lb (3.4 N-m) **(Figure 16-105, Page 16-43)**.
26. Connect the Forward/Reverse shifter and bracket to the transaxle.
 - 26.1. Install the three screws (2) securing the Forward/Reverse shifter cable bracket (1) to the transaxle and tighten them to 135 in-lb (15.3 N-m) **(Figure 16-40, Page 16-16)**.
 - 26.2. Place the woodruff key (9) on the shifter shaft **(Figure 16-40, Page 16-16)**.
 - 26.3. Place the shifter lever (6) (aligned with the woodruff key) onto the Forward/Reverse shaft (15).
 - 26.4. Install the nut (3), washer (4), and bolt (7) on the Forward/Reverse shifter lever and tighten to 36 in-lb (4.1 N-m) **(Figure 16-40, Page 16-16)**.
 - 26.5. Position the shifter cable in the shifter cable mounting bracket on the transaxle and tighten the mounting nuts to 22 ft-lb (29.8 N-m). Connect shifter cable rod end to the shifter arm **(Figure 16-106, Page 16-44)**.
27. Attach the ground wire to the mounting screw on the oil filler tube mounting bracket and tighten to 50 in-lb (5.7 N-m) **(Figure 16-107, Page 16-44)**.

Unitized Transaxle Installation, Continued:

28. Connect accelerator cable to actuator cam in the electrical box. Position the accelerator cable in mounting slot in the wall of the electrical box and tighten mounting nuts to 18 in-lb (2.0 N·m) (**Figure 16-108, Page 16-44**). Install electrical box cover and tighten mounting screw.
29. Pull fuel line from impulse line fitting of the fuel pump, connect it to the carburetor and secure with a hose clamp (**Figure 16-109, Page 16-44**).
30. Connect the impulse line to the fuel pump and secure it with the hose clamp (**Figure 16-110, Page 16-45**).
31. Connect air intake hose to carburetor and secure hose clamp (**Figure 16-111, Page 16-45**).
32. Connect carburetor vent tube to carburetor and secure with hose clamp (**Figure 16-112, Page 16-45**).
33. Connect the differential lock cable end to the differential lock handle.
 - 33.1. Connect the end of the differential lock cable to the differential lock handle (step 1) (**Figure 16-113, Page 16-46**).

**Figure 16-106 Connect Shifter Cable****Figure 16-107 Engine Ground****Figure 16-108 Connect Cable to Cam****Figure 16-109 Connect Fuel Line**

- 33.2. Push down on the cable to secure the end of the cable to the differential lock handle (step 2) (**Figure 16-113, Page 16-46**).
- 33.3. Rotate the cable counterclockwise to route the cable through the bracket (step 3) (**Figure 16-113, Page 16-46**).
- 33.4. Push the cable sheath toward the front of the vehicle to secure the cable to the bracket (**Figure 16-117, Page 16-50**).
- 33.5. Secure the cable to the vertical support with a wire tie (6) as shown (**Figure 16-117, Page 16-50**).
34. Install transaxle drain plug and tighten to 21 ft-lb (28.5 N·m).
35. Fill transaxle with 30.4 oz. (.9 liter) 80-90 Wt. API Class GL-3 or 80-90 Wt. AGMA Class EP gear lube. Install and tighten the level indicator hole plug to 21 ft-lb (28.5 N·m).

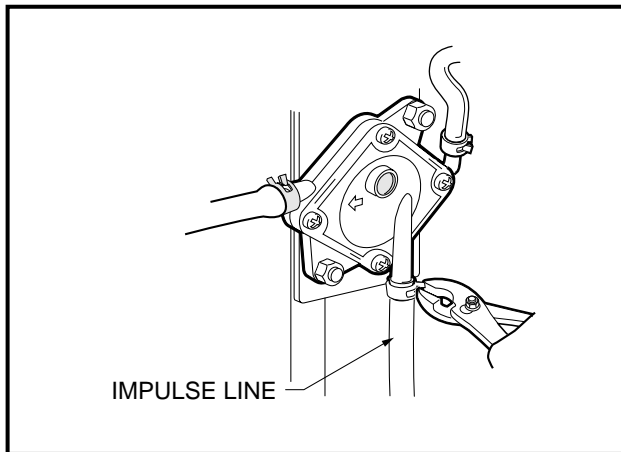

Figure 16-110 Impulse Line

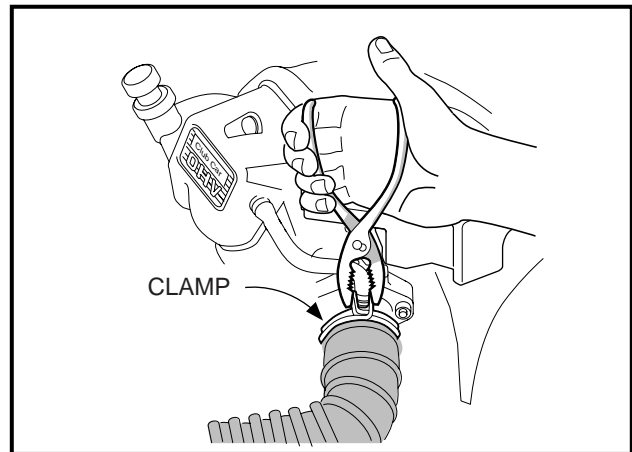

Figure 16-111 Air Intake Hose

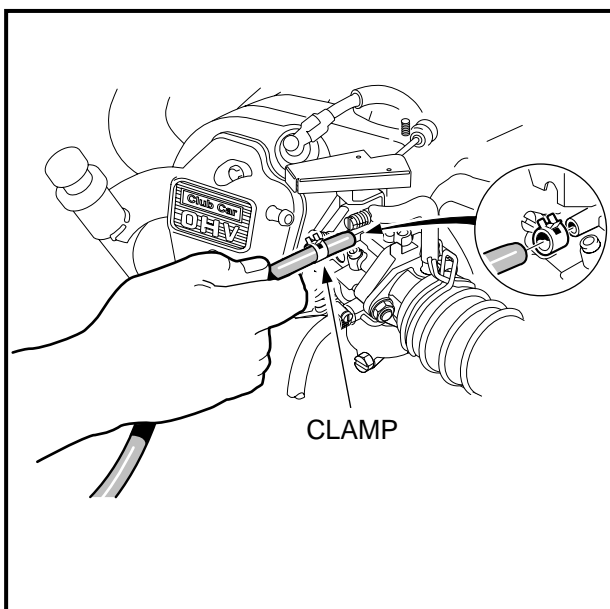

Figure 16-112 Carburetor Vent Tube

Unitized Transaxle Installation, Continued:

36. Check that all wiring is secured properly. **See following WARNING.**

⚠ WARNING

- If wires are removed or replaced make sure wiring and wiring harness is properly routed and secured to vehicle frame. Failure to properly route and secure wiring could result in vehicle malfunction, property damage or personal injury.

37. Connect the spark plug wire.
38. Connect the battery cables, positive cable (+) first and tighten to 20 ft-lb (27.1 N-m).
39. Adjust the engine RPM setting. **See Engine RPM Adjustment, Section 14, Page 14-13.**

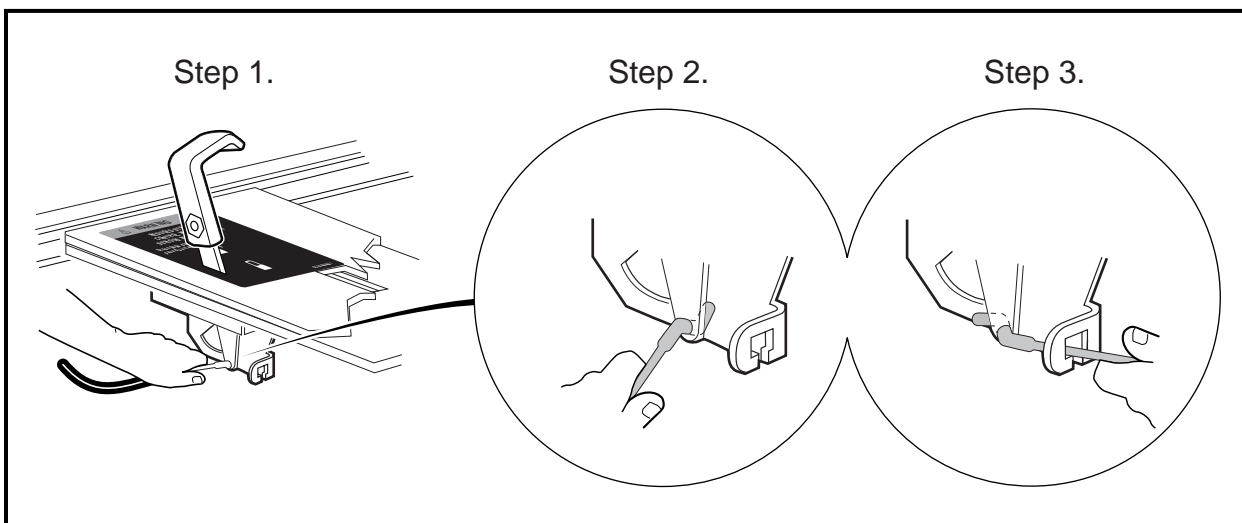

Figure 16-113 Differential Cable End Installation

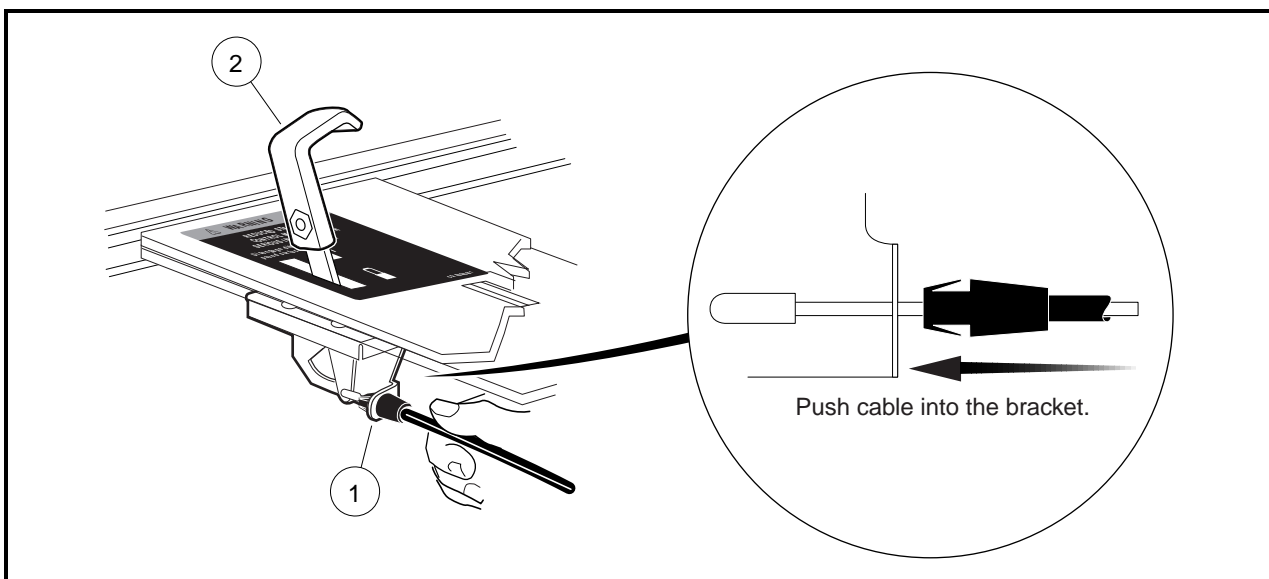

Figure 16-114 Differential Cable Installation

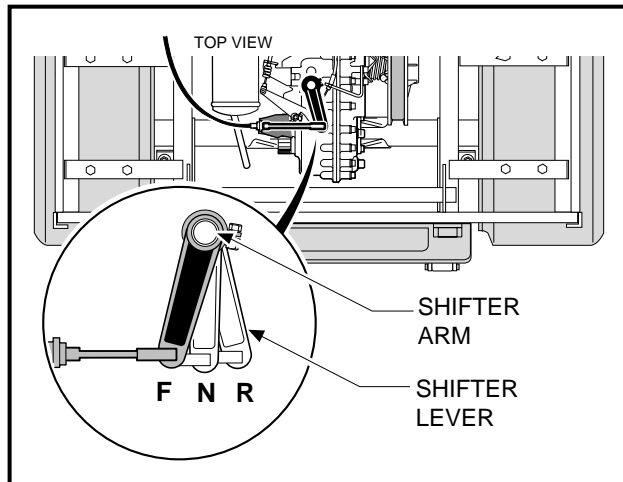

Figure 16-115 F&R Positions

FORWARD/REVERSE (F&R) SHIFTER CABLE

Read **DANGER** and **WARNING** on page 16-1.

If the F&R shifter cable is damaged in any way, it must be replaced.

F&R SHIFTER CABLE REMOVAL

NOTE: Before removing cable, note cable routing and positions of wire ties or other devices securing the cable to the vehicle. When reinstalled, cable must be routed and secured as it was originally.

1. Remove the ball joint socket (2) from the F&R shifter assembly ball stud (3) (**Figure 16-116, Page 16-48**).
2. Remove the ball joint socket (10) from the shifter arm ball stud (11) on the transaxle (**Figure 16-116, Page 16-48**).
3. Loosen the retaining nuts (5) on both ends of the cable and remove the wire tie (**Figure 16-116, Page 16-48**).
4. Remove cable from the vehicle.

F&R SHIFTER CABLE INSTALLATION

1. From the F&R shifter, route the cable exactly as it was originally, to the transaxle shifter lever.
2. Secure the cable with retaining nut (5) on each side of the shifter cable support bracket at the transaxle (**Figure 16-116, Page 16-48**). Tighten nuts to 22 ft-lb (29.8 N·m).
3. Secure the cable with retaining nut (5) on each side of the shifter cable support bracket at the F&R assembly (**Figure 16-116, Page 16-48**). Tighten nuts to 43 in-lb (4.9 N·m).
4. Install the ball joint socket (10) on the shifter lever ball stud (11) on the transaxle (**Figure 16-116, Page 16-48**).
5. Install the ball joint socket (2) on the F&R shifter assembly ball stud (3) (**Figure 16-116, Page 16-48**).
6. Install wire tie (8) to secure wire harness to cable at the support bracket near the F&R shifter assembly (**Figure 16-116, Page 16-48**). See following **WARNING**.

F&R Shifter Cable Installation, Continued:

⚠ WARNING

- If wires are removed or replaced, make sure wiring and wiring harness is properly routed and secured to vehicle frame. Failure to properly route and secure wiring could result in vehicle malfunction, property damage or personal injury.

F&R SHIFTER CABLE ADJUSTMENT

With the shifter lever of the unitized transaxle in the NEUTRAL position (**Figure 16-115, Page 16-47**), the Forward/Reverse handle (9) (**Figure 16-116, Page 16-48**) should be straight up. For minor adjustments, the nut (1) may be loosened and the ball joint socket (2) rotated to get the proper adjustment (**Figure 16-116, Page 16-48**). See following **CAUTION**.

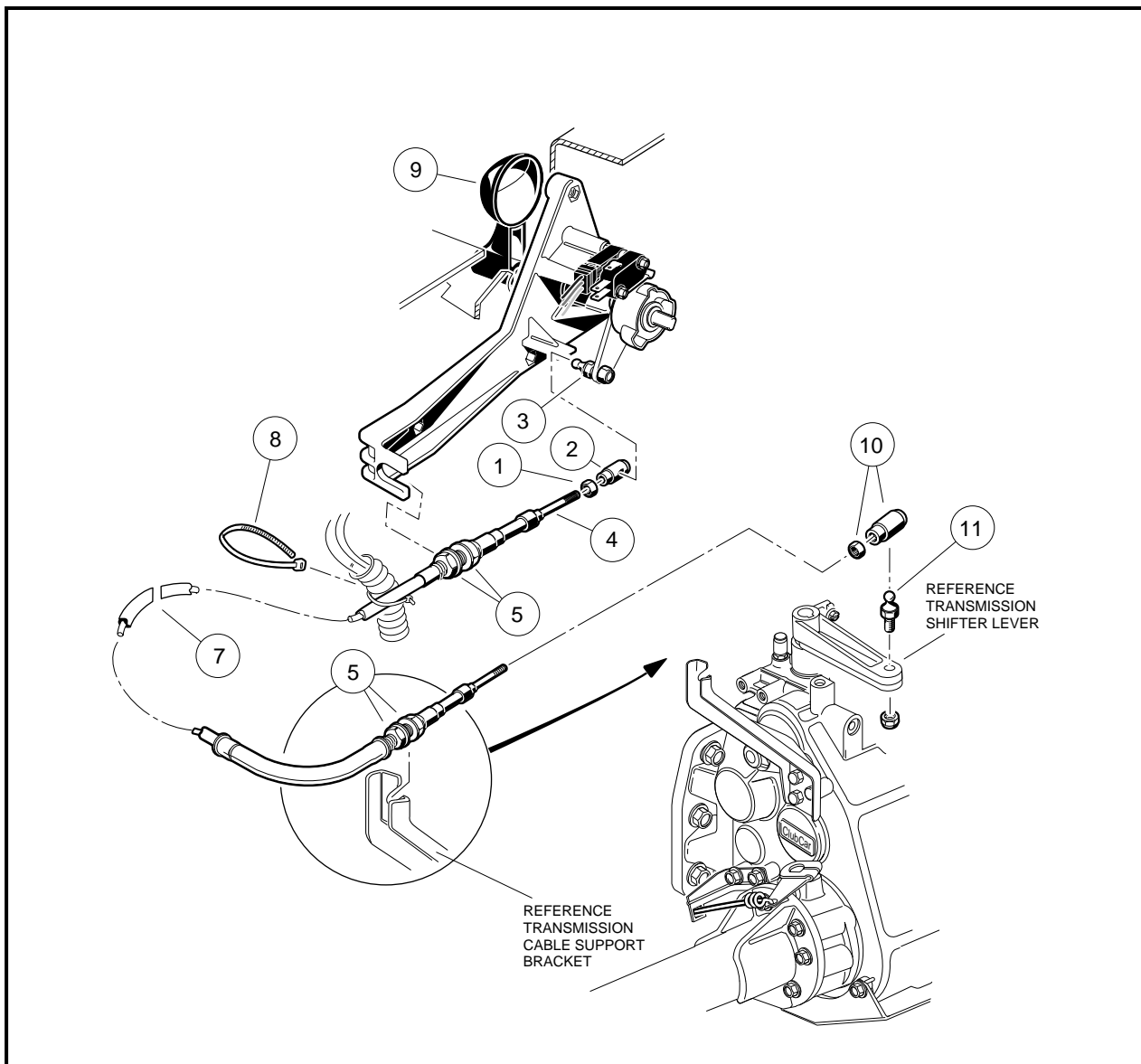

Figure 16-116 F&R Shifter Cable

▲ CAUTION

- Be sure threads of cable are engaged in ball joint socket at least 1/4 inch (6.35 mm). If ball joint socket comes loose from the cable, the F&R shifter will not operate properly.

For major adjustments, the cable retaining nuts (5) must be loosened and adjusted. When the cable is properly adjusted, with the Forward/Reverse handle (9) (**Figure 16-116, Page 16-48**) in the NEUTRAL position, the shift lever of the transaxle will also be in the NEUTRAL position (**Figure 16-115, Page 16-47**). Retighten nuts (5) at transaxle to 22 ft-lb (29.8 N·m); retighten nuts (5) at the F&R assembly to 43 in-lb (4.9 N·m).

DIFFERENTIAL LOCK SYSTEM

Read **DANGER** and **WARNING** on page 16-1.

If the differential lock cable is damaged in any way, it must be replaced. See following **WARNING**.

▲ WARNING

- If for any reason the differential lock system is not operating correctly, the system must be repaired or replaced before attempting to operate the vehicle. With the differential lock engaged, vehicle turning functions are greatly reduced. Failure to heed this warning could result in loss of vehicle control and severe personal injury.

DIFFERENTIAL LOCK SYSTEM INSPECTION

The differential lock system should periodically be inspected for proper operation.

1. Place chocks at the front wheels and lift the rear of the vehicle with a floor jack. Then place jack stands under the axle tubes to support the vehicle. See **WARNING** on page 16-1.
2. With the differential lock handle in the forward position (unlocked), rotate one of the rear wheels by hand. The wheel should be fairly easy to rotate and the other rear wheel should rotate in the **opposite** direction, indicating that the differential lock is **not** engaged. If this is not the case, the differential handle, cable or housing must be repaired or replaced before attempting to drive the vehicle.
3. With the wheels at rest, pull the differential lock handle toward the rear of the vehicle (locked position). Observe the cable end and differential lock arm on the differential lock housing. The cable should move freely when the handle is moved. Initially, there may be slack in the cable at the differential housing. Rotation of the rear tire will eliminate this slack when the differential lock is fully engaged.
4. With the differential lock handle in the rear position (locked), rotate one of the rear wheels by hand. The wheel should be a great deal harder to rotate and the other rear wheel should rotate in the **same** direction, indicating that the differential lock **is** engaged. If this is not the case, the differential handle, cable or housing must be repaired or replaced before attempting to drive the vehicle.

DIFFERENTIAL LOCK CABLE REMOVAL

1. Place the differential lock handle in the disengaged (unlocked) position.
2. Remove wire tie (6) securing the cable to the vertical support (**Figure 16-117, Page 16-50**).
3. Using a pair of pliers, apply pressure to the locking tabs of the cable end (1) where it attaches to the differential lock handle mounting bracket (**Figure 16-13, Page 16-8**).
4. While maintaining pressure on the locking tabs, pull the differential lock cable toward the rear of the vehicle to disconnect the cable from the bracket (**Figure 16-13, Page 16-8**).
5. With the cable disconnected from the bracket, rotate the cable connector toward the driver side of the vehicle to disconnect the cable from the differential lock lever (1) (**Figure 16-14, Page 16-9**).

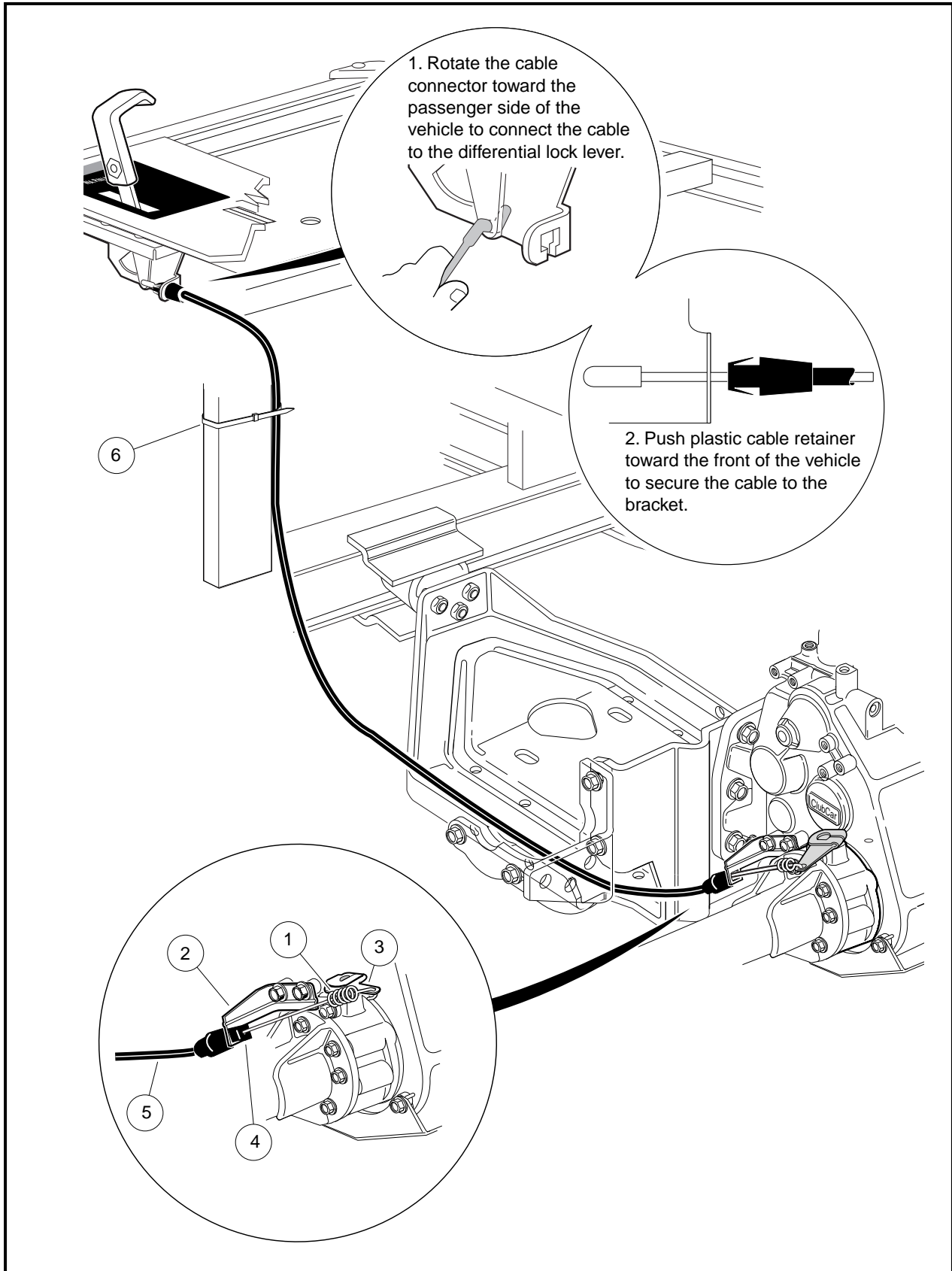

Figure 16-117 Differential Lock Cable Routing

Differential Lock Cable Removal, Continued:

6. Unhook the cable spring (1) from the differential lock arm (3) (**Figure 16-117, Page 16-50**).
7. Using a pair of pliers, apply pressure to the locking tabs of the cable end (4) where it attaches to the cable mounting bracket (2) at the transaxle (**Figure 16-117, Page 16-50**).
8. Pull cable (5) toward the front of the vehicle in order to remove the cable from the bracket (2) (**Figure 16-117, Page 16-50**).
9. Remove the cable from the vehicle.

DIFFERENTIAL LOCK CABLE INSTALLATION

1. Route the cable through the engine mounting plate as illustrated (**Figure 16-117, Page 16-50**).
2. Route the cable spring (1) through the cable bracket (2) as illustrated (**Figure 16-117, Page 16-50**).
3. Connect the differential lock cable spring end (1) to the differential lock arm (3) on the differential lock housing (**Figure 16-117, Page 16-50**).
4. Push the cable (5) toward the rear of the vehicle in order to secure the cable to the bracket (2) (**Figure 16-117, Page 16-50**).
5. Connect the differential lock cable end to the differential lock handle.
 - 5.1. Connect the end of the differential lock cable to the differential lock handle (step 1) (**Figure 16-113, Page 16-46**).
 - 5.2. Push down on the cable to secure the end of the cable to the differential lock handle (step 2) (**Figure 16-113, Page 16-46**).
 - 5.3. Rotate the cable sheath counterclockwise to route the cable through the bracket (step 3) (**Figure 16-113, Page 16-46**).
 - 5.4. Push the cable toward the front of the vehicle to secure the cable to the bracket (**Figure 16-114, Page 16-46**).
 - 5.5. Secure the cable to the vertical support as shown with a wire tie (6) (**Figure 16-117, Page 16-50**).
6. Inspect the differential lock system for proper operation. **See Differential Lock System Inspection on page 16-49.**

SECTION 17 – TORQUE CONVERTER

⚠ DANGER

- *Gasoline – Flammable! Explosive! Do not smoke. Keep sparks and flames away from vehicle and service area. Service only in a well-ventilated area.*
- *Do not operate gasoline vehicle in an enclosed area without proper ventilation. The engine produces carbon monoxide, which is an odorless, deadly poison.*

⚠ WARNING

- Only trained technicians should repair or service this vehicle. Anyone doing even simple repairs or service should have knowledge and experience in electrical and mechanical repair.
- Follow the procedures exactly as stated in this manual, and heed all DANGER, WARNING, and CAUTION statements in this manual as well as those affixed to the vehicle.
- Wear safety glasses or approved eye protection while servicing vehicle. Wear a full face shield and rubber gloves when working with battery.
- Turn key switch OFF, place Forward/Reverse handle in the NEUTRAL position, and remove key prior to servicing.
- Do not wear loose clothing. Remove jewelry such as rings, watches, chains, etc. before servicing vehicle.
- Use insulated tools when working near batteries or electrical connections. Use extreme caution to avoid shorting of components or wiring.
- Moving parts! Do not attempt to service the vehicle while it is running.
- Hot! Do not attempt to service hot engine or exhaust system. Failure to heed this warning could result in severe burns.
- Frame ground – Do not allow tools or other metal objects to contact frame when disconnecting battery cables or other electric wiring. Never allow a positive wire to touch the vehicle frame, engine, or any other metal component.
- To avoid unintentionally starting the vehicle:
 - Disconnect battery cables, negative cable (–) first.
 - Disconnect the spark plug wire from the spark plug.
- The prop rod on the vehicle should be securely engaged prior to servicing. Remove all cargo before raising the bed. Do not disengage prop rod until all persons are clear of cargo bed area. Do not drop cargo bed; lower gently and keep entire body clear. Failure to follow these instructions could result in severe personal injury.

GENERAL INFORMATION

The torque converter consists of a drive clutch, a driven clutch, and a drive belt. The drive clutch, which is mounted to the engine, is in the open position when the engine is at idle. At this point, the belt is riding at a low position (smaller diameter) on the drive clutch. The driven clutch is mounted on the transaxle. It is in the closed position, and the drive belt is riding at a high position (large diameter) on it when the engine is at idle.

At the point of clutch engagement, the speed ratio of the drive clutch to the driven clutch is 3.5 to 1. This ratio provides excellent starting and low-speed torque.

As engine speed increases, centrifugal force on internal weights close the drive clutch, pushing the belt up to a higher position on the clutch (increasing the diameter of the belt loop). As the diameter of the belt loop increases at the drive clutch, the driven clutch is forced open as the diameter of its belt loop decreases. At governed top speed, the ratio of drive clutch to driven clutch is .92 to 1.

On steep grades, or when the vehicle is heavily loaded, higher torques are achieved through the use of a torque-sensing ramp device on the driven clutch. This device overcomes the force of the centrifugal weights to close the driven clutch and open the drive clutch, thus increasing axle torque with little or no change in engine RPM.

The engine and torque converter rotate clockwise as viewed from the clutch side of the engine.

To provide optimum performance for the OHV engine and powertrain, the vehicle uses a pair of tuned clutches.

To properly assemble and disassemble the torque converter, the following tools should be used:

- Torque Converter Tool Kit (CCI 1014510) (**Figure 17-1, Page 17-2**).
- Scribe or small pick (not included in torque converter tool kit).

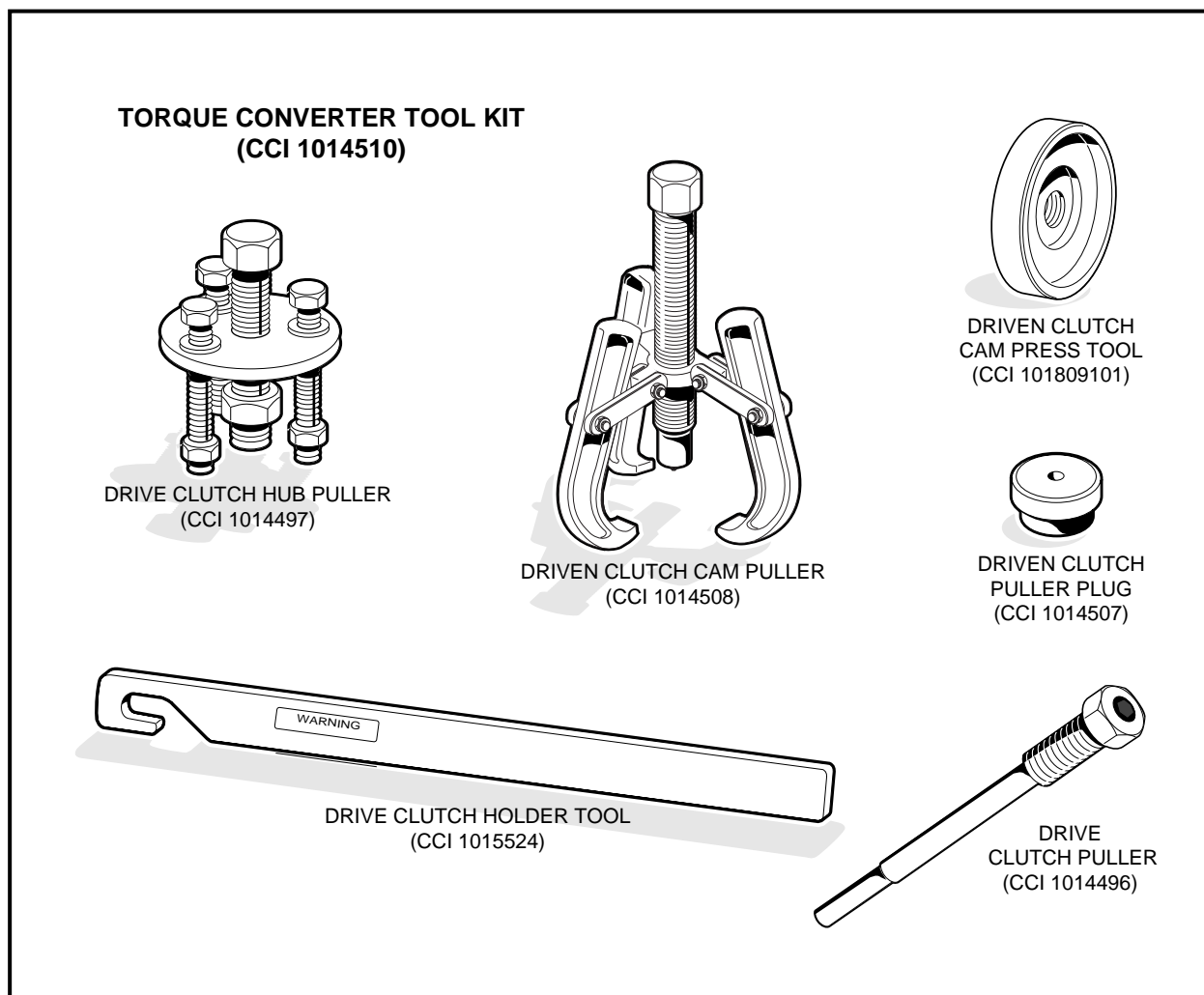

Figure 17-1 Torque Converter Tool Kit

TROUBLESHOOTING

Read **DANGER** and **WARNING** on page 17-1.

Maintaining proper adjustment of the engine and governor, as well as the torque converter, is essential to the troubleshooting process. If these adjustments are within Club Car specifications and, when climbing a steep hill, the engine begins to lose RPM before the drive belt reaches the top of the driven clutch, there is a torque converter problem.

If the torque converter is not operating properly:

1. Check the governor and throttle settings. **See Section 14 – Fuel System.**
2. Inspect the driven clutch for dirt and dust buildup on its component parts. Clean the driven clutch with water to remove any dust or dirt, then drive the vehicle and check for proper operation.
3. If cleaning the driven clutch does not solve the problem, disassemble and thoroughly clean all parts of the drive clutch. Be sure to clean the plastic drive buttons (10) (**Figure 17-5, Page 17-6**).

DRIVE BELT

Read **DANGER** and **WARNING** on page 17-1.

The drive belt should be inspected semiannually for wear and (or) glazing. If it is excessively worn, frayed, or glazed, replace the belt.

As the drive belt wears, the engine RPM will increase to compensate for the change in torque converter ratio. This will keep the vehicle's maximum ground speed correct at 17-19 mph (27-31 km/h).

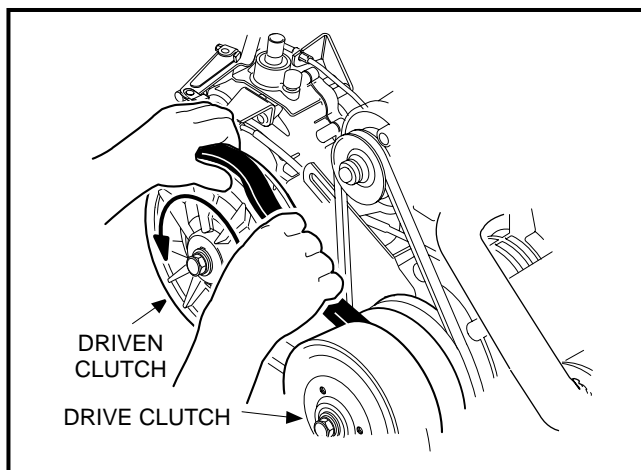

Figure 17-2 Drive Belt Removal

DRIVE BELT REMOVAL

1. Place the Forward/Reverse handle in the NEUTRAL position, chock the wheels and disconnect the battery, negative cable first. Disconnect the spark plug wire from the spark plug.
2. Grasp the belt midway between the drive and driven clutches. Lift upward on the belt to force the sheaves of the DRIVEN clutch apart, then roll the belt off the DRIVEN clutch by rotating the clutch counterclockwise (**Figure 17-2, Page 17-3**). **See following CAUTION.**

Drive Belt Removal, Continued:**⚠ CAUTION**

- *Make sure fingers are not underneath the belt when rolling the belt off the driven clutch.*
3. Remove the belt from the drive clutch.

DRIVE BELT INSTALLATION

1. Position the new belt on the drive clutch, then start the belt over the top of the driven clutch.
2. With the belt started onto the driven clutch, rotate the driven clutch counterclockwise and roll the belt over the driven clutch sheaves and onto the clutch.

DRIVE CLUTCH

Read **DANGER** and **WARNING** on page 17-1.

⚠ CAUTION

- *Be very careful when handling the clutches. A clutch that has been dropped will not be properly balanced. If either clutch is dropped, assume that it is damaged and replace it.*

DRIVE CLUTCH REMOVAL

1. Remove the drive belt as instructed. **See Drive Belt Removal on page 17-3.**
2. Loosen the starter/generator mounting and adjusting hardware and then remove the starter belt. **See WARNING on page 17-1.**
3. Remove the drive clutch retaining bolt (17) and mounting washer (19) (**Figure 17-5, Page 17-6**). **See also Figure 17-3, Page 17-5.**

NOTE: The drive clutch mounting bolt has left-hand threads.

The crankshaft has left-hand threads at the clutch mounting hole.

4. Lubricate the threaded portion of the clutch puller tool with a light oil and thread the clutch puller tool into the clutch retaining bolt hole.
5. Using a 1/2 inch drive air wrench, tighten the clutch puller tool. The drive clutch will come free of the crankshaft (**Figure 17-4, Page 17-5**).
6. Support the drive clutch assembly in your hand and back the clutch puller tool out of the crankshaft.

⚠ CAUTION

- *Do not hit or tap the clutch with a hammer. Do not pry the clutch. These actions will damage the clutch.*

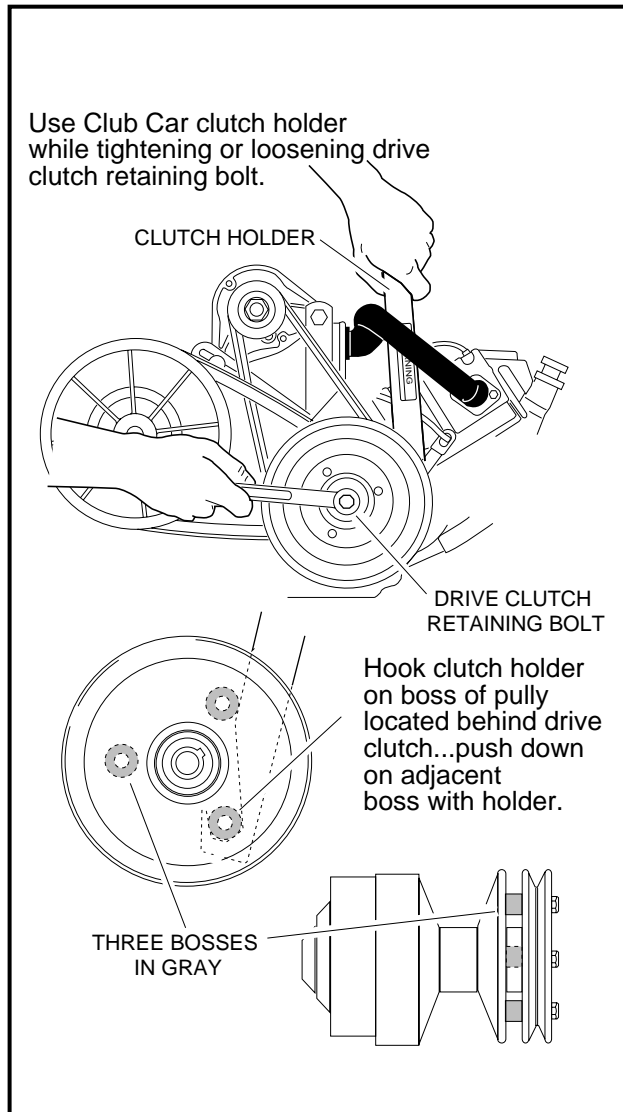

Figure 17-3 Loosen Retaining Bolt

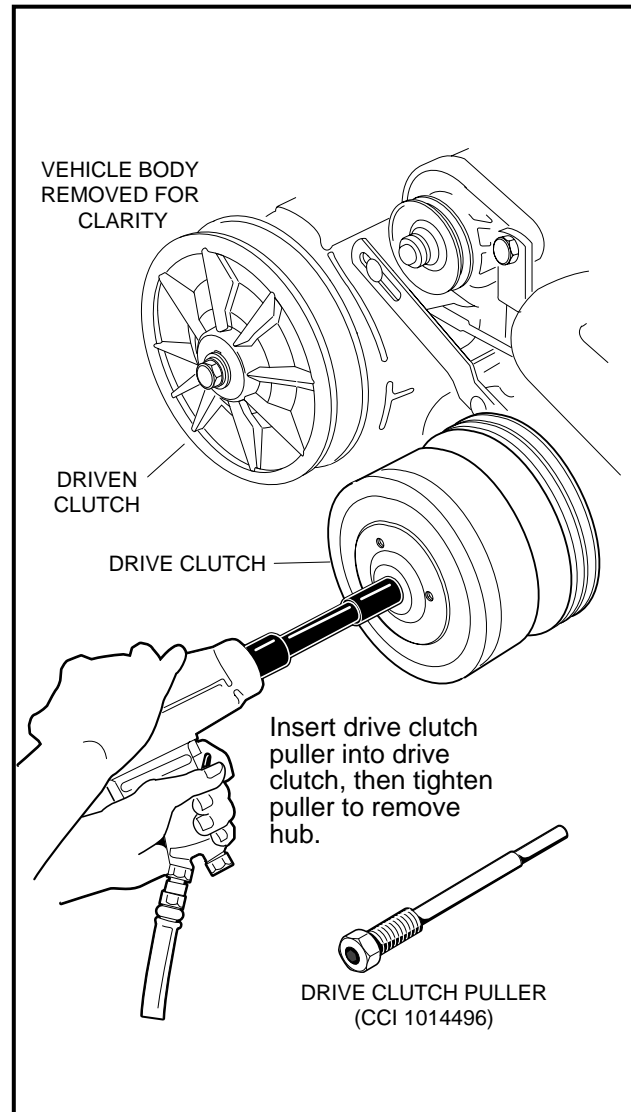

Figure 17-4 Drive Clutch Removal

DRIVE CLUTCH CLEANING AND INSPECTION

1. Use a dry, lint-free cloth to clean clutch parts.

⚠ CAUTION

- Do not lubricate the drive clutch. Lubricants attract dirt and dust, which interfere with proper clutch operation.
- Use only a dry cloth to lightly wipe the shaft of the fixed face assembly (7) (Figure 17-5, Page 17-6). Do not use a brush or steel wool. These will damage the surface of the shaft.
- Do not use solvents. Solvents will damage the lubricating characteristics of the bushings.

2. Inspect the belt contact surfaces of the clutch sheaves for wear. If any area of a sheave contact surface has wear of 0.060 inch (1.52 mm) or more, the clutch should be replaced.

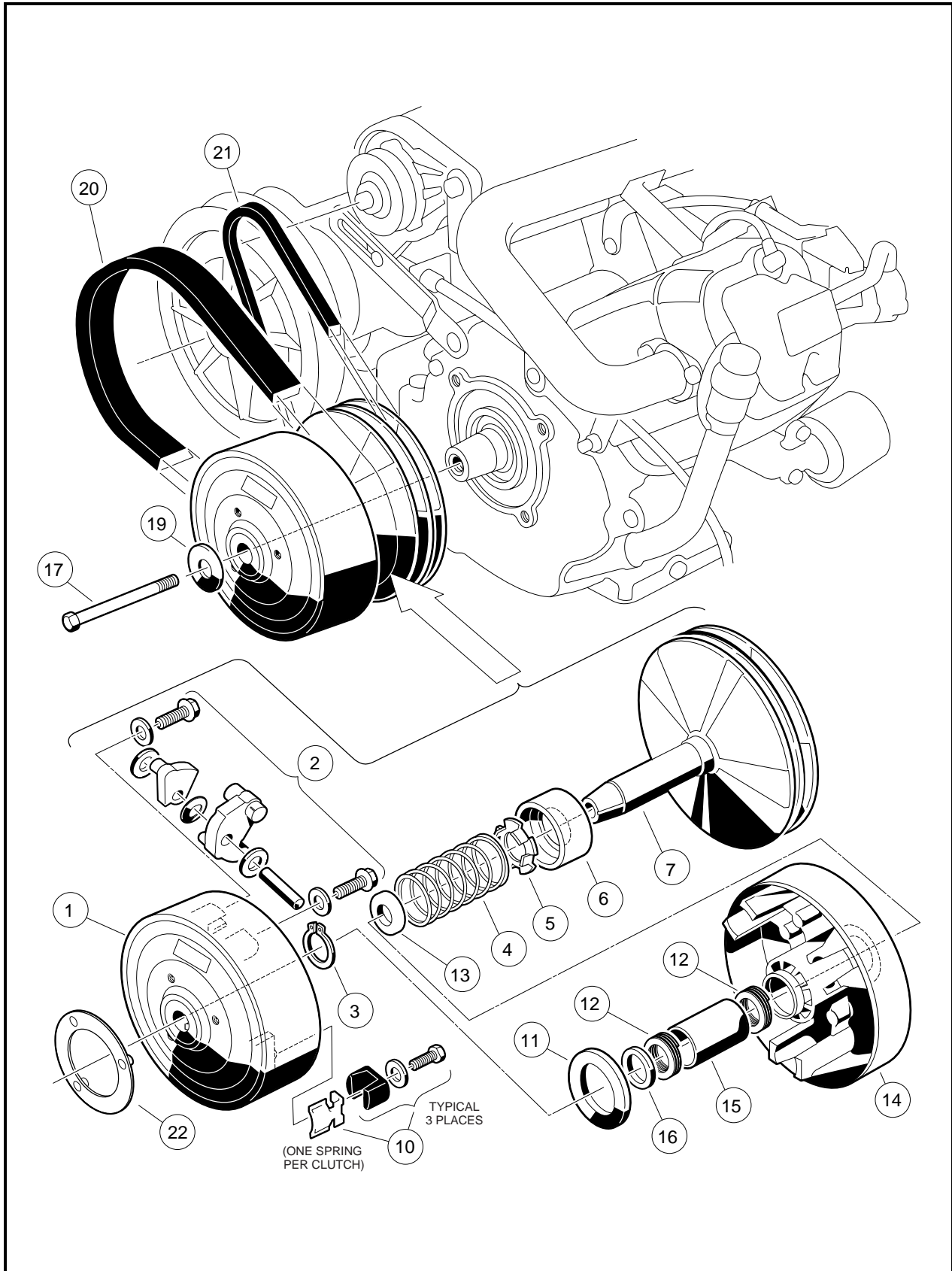

Figure 17-5 Drive Clutch Assembly

DRIVE CLUTCH DISASSEMBLY

▲ CAUTION

- The drive clutch is balanced as an assembly. Before disassembly, make match marks on the clutch cover and on the moveable face assembly so they can be reassembled in the same positions (**Figure 17-6, Page 17-7**).
1. Make match marks on the clutch cover and on the moveable face casting (**Figure 17-6, Page 17-7**).
 2. Remove the clutch cover (1) (**Figure 17-5, Page 17-6**):
 - 2.1. Remove the clutch plug (22) (**Figure 17-5, Page 17-6**).
 - 2.2. Thread the center bolt of the Drive Clutch Hub Puller (CCI 1014497) into clutch until the stop nut touches the clutch, then back the bolt out one-half turn (**Figure 17-7, Page 17-7**).
 - 2.3. Thread the three small bolts of the puller into corresponding holes in the clutch. Tighten bolts evenly, making sure the face of the puller plate is parallel to the face of the clutch (**Figure 17-7, Page 17-7**).
 - 2.4. Unscrew the puller center bolt out of the clutch to pull clutch cover off.
 3. Remove the thrust washer (11) from the moveable face (14) (**Figure 17-5, Page 17-6**).
 4. Remove the drive buttons (**Figure 17-8, Page 17-8**).
 - 4.1. Remove the screws, flat washers, drive button take-up spring, and drive buttons as shown (**Figure 17-8, Page 17-8**).
 5. Remove the clutch weights (**Figure 17-9, Page 17-8**):
 - 5.1. Remove the screws and flat washers attaching the weights as shown (**Figure 17-9, Page 17-8**).
 - 5.2. Pull the weight assemblies, with pins, from the clutch.
 - 5.3. Before removing, note the orientations of the wave washer and of the primary and secondary weights to one another (**Figures 17-12 and 17-13, Page 17-10**). Remove the plastic washers, weights and wave washer from the pin. Retain all parts.

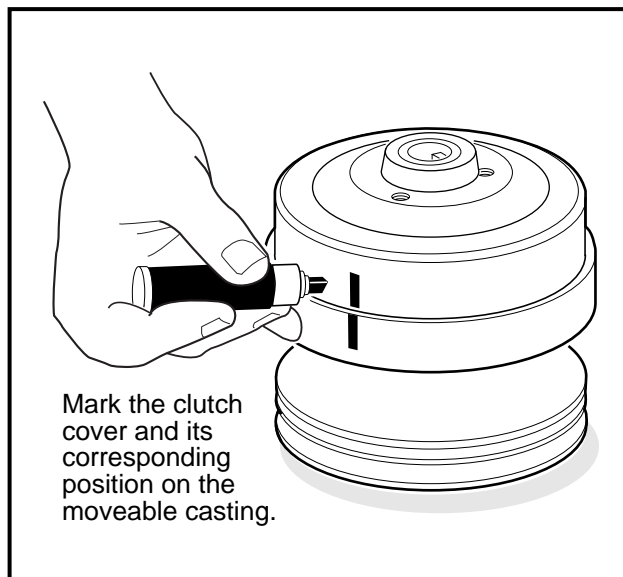

Figure 17-6 Mark Clutch Cover

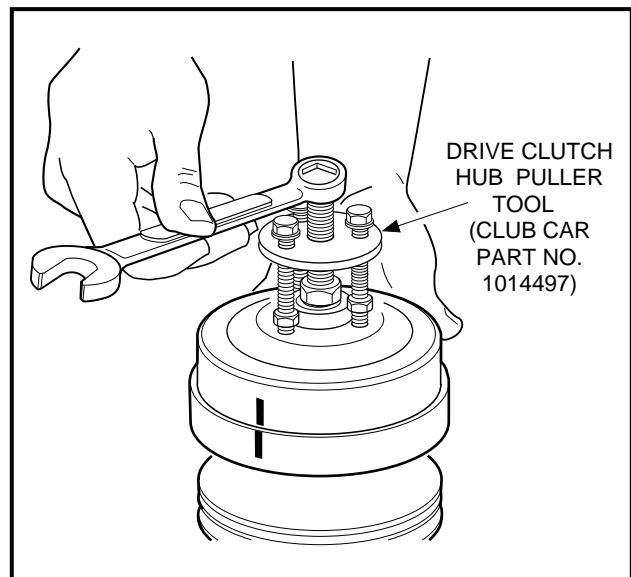

Figure 17-7 Remove Clutch Cover

Drive Clutch Disassembly, Continued:

- Remove the retaining ring (3) from the shaft of the fixed face assembly (7) and slide the moveable face (14) off the shaft (**Figure 17-5, Page 17-6**). See following **NOTE**.

NOTE: If the moveable face is removed from the hub of the fixed face, the spiral back-up rings (12) (**Figure 17-5, Page 17-6**) must be replaced with new ones.

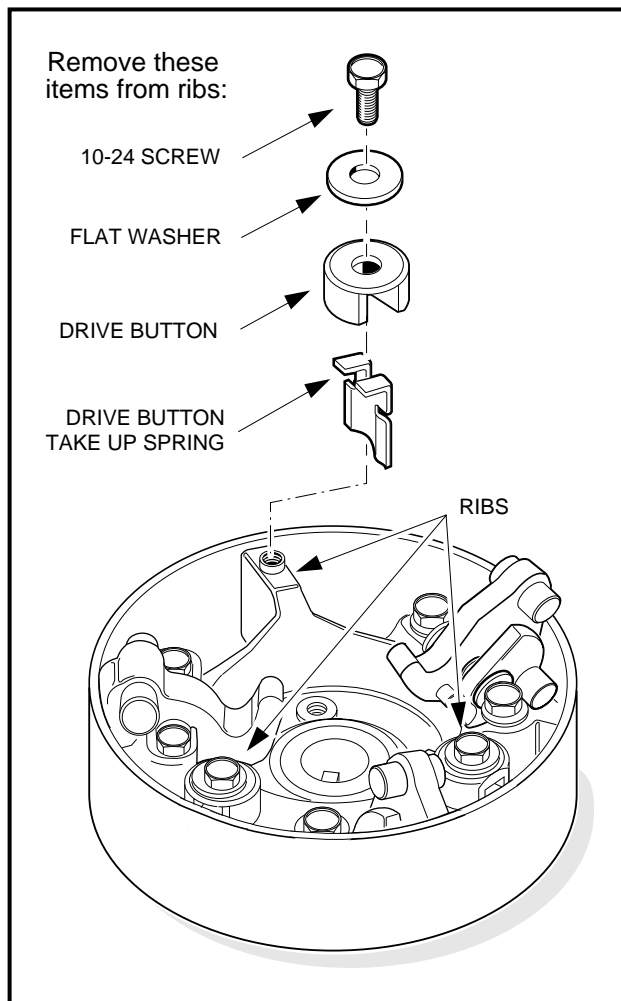

Figure 17-8 Drive Button Mounting

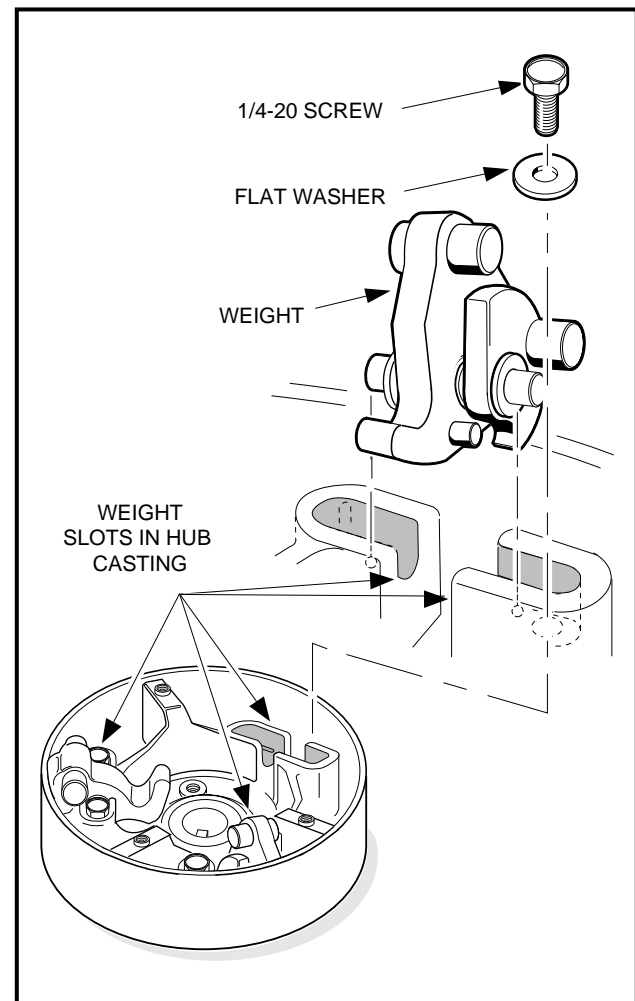

Figure 17-9 Weight Position

- Remove the spacer (16), and spring (4) and retainer (5). The spring retainer can be removed from the spring if necessary (**Figure 17-5, Page 17-6**).
- If necessary, remove idler bearing. Use a press to remove the bearing (**Figure 17-10, Page 17-9**). See following **NOTE**.

NOTE: Do not remove the idler bearing unless it needs to be replaced. If idler bearing is removed, replace it with a new bearing.

- Use a scribe or small pick to remove the spiral backup rings (12) from each end of the bore in the fixed face assembly (**Figure 17-5, Page 17-6 and Figure 17-11, Page 17-9**). Discard the rings.

INSPECTION OF DRIVE CLUTCH PARTS

1. Inspect the idler bearing (6) for smooth rotation or seal damage (**Figure 17-5, Page 17-6**).

NOTE: It is normal for a small amount of grease to be present at the edge of seal.

2. Inspect the bore of the moveable face assembly (14) for scarring or wear. The moveable face assembly must be replaced if the bore is worn to a diameter of 0.883 inch (22.4 mm) or larger (**Figure 17-5, Page 17-6**).
3. Inspect the steel shaft (7) on the fixed face assembly. There should be no measurable wear anywhere on the shaft. Replace the shaft if it is worn, scratched, or damaged (**Figure 17-5, Page 17-6**).
4. Inspect the thrust washer (11) for wear. If it is worn more than 0.030 inch (0.76 mm), turn it over or replace it with a new one (**Figure 17-5, Page 17-6**).
5. Inspect the primary weights (2) and the hub casting for wear. If the primary weights show signs they are touching the casting, the tips of the weights have worn beyond specification and they must be replaced (**Figure 17-5, Page 17-6**).
6. Inspect the pins on the primary weights (2). There should be no measurable wear. Replace them if they are worn, scratched, or damaged (**Figure 17-5, Page 17-6**).
7. Inspect the drive belt pulley sheaves for excessive wear or damage. If the sheaves are excessively worn or damaged, replace the entire fixed face drive assembly.

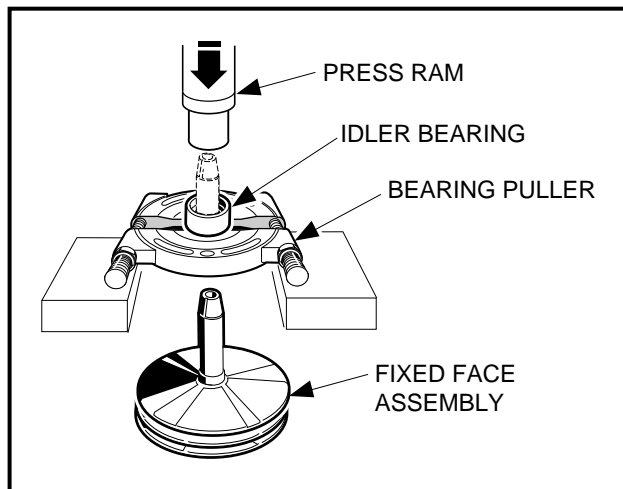

Figure 17-10 Remove Idler Bearing

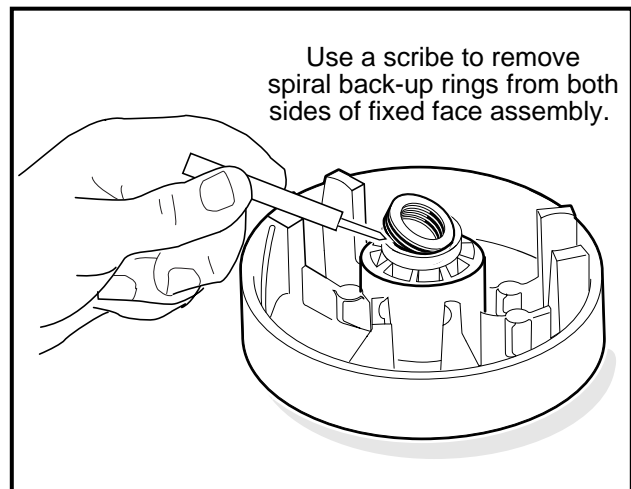

Figure 17-11 Spiral Back-up Rings

DRIVE CLUTCH ASSEMBLY

1. Press idler bearing (6) onto the shaft of the fixed face assembly (7). Press on the inner race of the bearing only. Make sure that the cup side of bearing is facing away from the fixed face (**Figure 17-5, Page 17-6**).
2. Using needle nose pliers, install the spring retainer (5) onto the spring (4) (**Figure 17-5, Page 17-6**).
3. Install the spring (4) and retainer (5) into the cup of the idler bearing (6) (**Figure 17-5, Page 17-6**).
4. Install the spacer (13) onto the shaft of the fixed face (**Figure 17-5, Page 17-6**).
5. Install a new spiral backup ring (12) in each end of the bore of the moveable face assembly (14) (**Figure 17-5, Page 17-6**).

Drive Clutch Assembly, Continued:

6. Install the moveable face assembly (14) onto the shaft of the fixed face assembly (7) (**Figure 17-5, Page 17-6**).

⚠ CAUTION

- To avoid damaging the spiral back-up rings, be very careful when installing the moveable face.
 - 6.1. Rotate the moveable face assembly clockwise while installing it onto the shaft.
 - 6.2. Install the retaining ring (3) (**Figure 17-5, Page 17-6**).
- 7. Install the primary weights on the mounting pins (**Figure 17-12, Page 17-10**).
- 8. Install a wave washer on each mounting pin. Make sure that the concave side of the washer faces the side of the primary weight with the small guide pin protruding from it (**Figure 17-12, Page 17-10**).
- 9. Install the secondary weights onto the mounting pins with the weight pins on the secondary weights pointing away from the primary weights. The wave washers should be between the primary and secondary weights (**Figure 17-13, Page 17-10**).

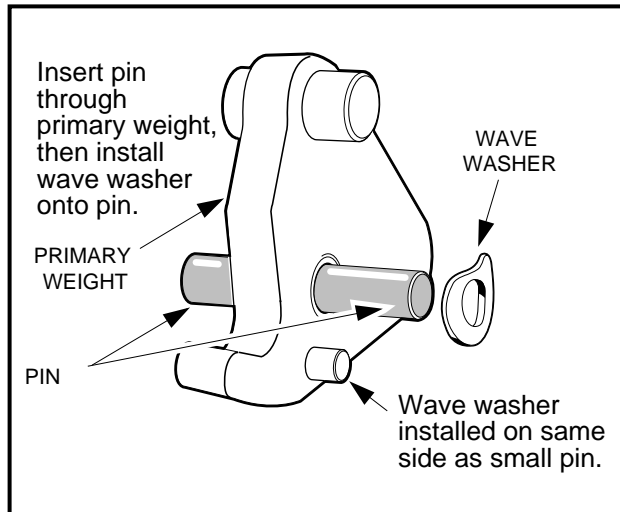
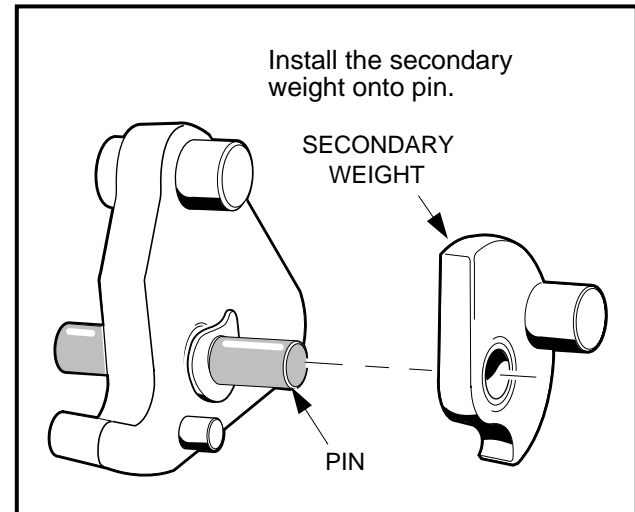
**Figure 17-12 Install Pin and Washer****Figure 17-13 Install Secondary Weight**

10. Install white plastic flat washers on each end of the mounting pin and push them against the outside surfaces of the weights. Center the weights and washers on the mounting pin (**Figure 17-14, Page 17-11**).
11. Install the weight assemblies into the slots in the hub casting (**Figure 17-9, Page 17-8**). Make sure the mounting pin protrudes an equal amount on each side of the weights when the assemblies are in position (**Figure 17-14, Page 17-11**).
12. Install the 1/4-20 screws and washers (2) and tighten them to 10 ft-lb (13 N·m) (**Figure 17-5, Page 17-6**).

NOTE: Make sure there is at least a (minimum) gap of 0.020 inch (0.51 mm) between each end of the mounting pin and the mounting screw.

13. Install one drive button take-up spring.
 - 13.1. Install spring on **right** side of any one of the three button mounting posts (when looking into the interior of the clutch cover with the rib at the twelve o'clock position) as shown (**Figure 17-15, Page 17-11**).
14. While compressing the take-up spring, install the drive button over the rib and take-up spring as shown (**Figure 17-8, Page 17-8**).

15. Install remaining two buttons.
16. Install a number 10-24 button retaining screw with flat washer through each button and into the rib. Tighten the screws to 34 in-lb (3.8 N·m) (**Figure 17-9, Page 17-8**).
17. Install the thrust washer (11) onto the moveable face assembly (**Figure 17-5, Page 17-6**).
18. Install the hub assembly (1) on the moveable face assembly and align the match marks made before disassembling the clutch. Press the hub assembly on by hand (**Figure 17-5, Page 17-6**).

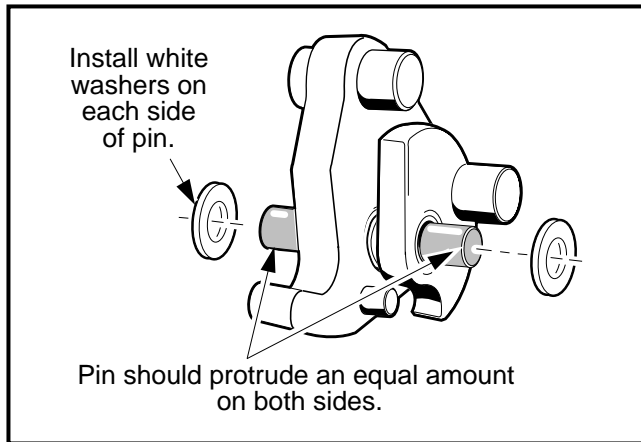

Figure 17-14 Install White Washers

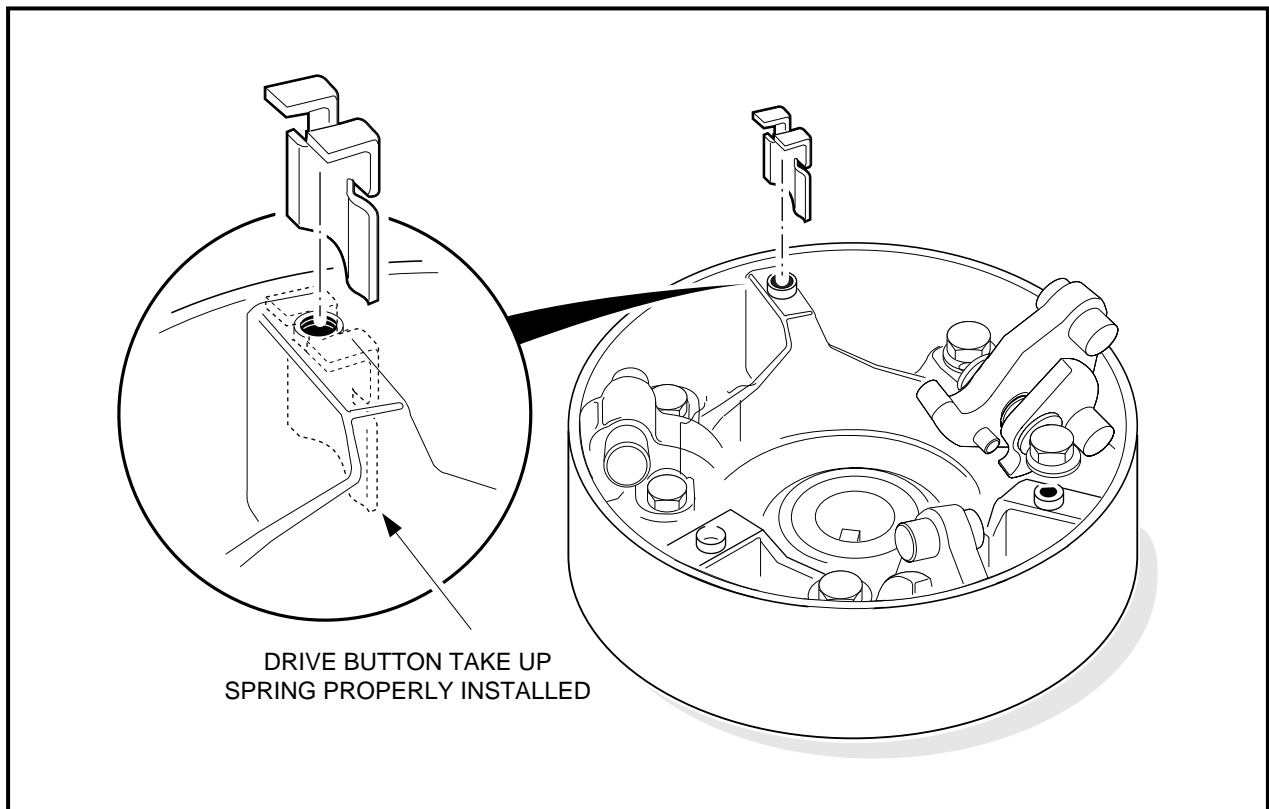

Figure 17-15 Correct Orientation of Drive Button Take-up Spring

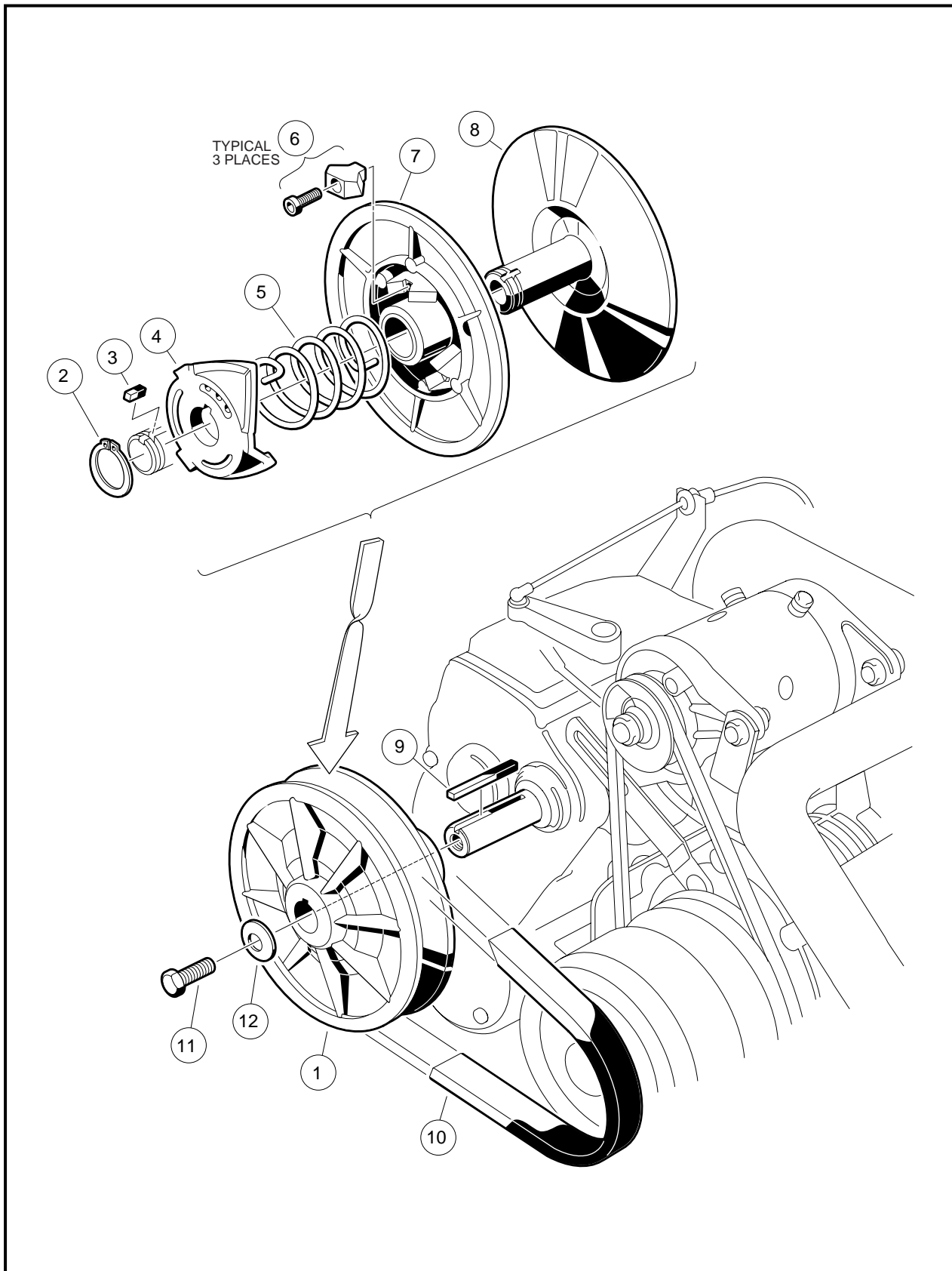

Figure 17-16 Driven Clutch Assembly

DRIVE CLUTCH INSTALLATION

1. Place the drive clutch assembly on the crankshaft taper. Position the mounting washer (with the green side facing out) on the bolt (17) and start the bolt into the crankshaft. **See following NOTE.**

NOTE: The drive clutch mounting bolt has left-hand threads.

2. Tighten the drive clutch retaining bolt (17) to 25 ft-lb (33.9 N·m) (**Figure 17-5, Page 17-6**).
3. Install the starter/generator belt and adjust belt tension. **See Section 12 – Electrical Components.** Tighten the starter/generator mounting hardware to 23 ft-lb (31.2 N·m) and the adjusting hardware to 13 ft-lb (17.6 N·m).
4. Install the drive belt. **See Drive Belt Installation on page 17-4.**
5. Connect the battery cables, positive (+) cable first.
6. Connect the spark plug wire to the plug.
7. Drive the vehicle and check for proper operation.

DRIVEN CLUTCH

Read **DANGER** and **WARNING** on page 17-1.

DRIVEN CLUTCH REMOVAL

1. Remove the drive belt. **See Drive Belt Removal on page 17-3.**
2. Remove the bolt (11) and mounting washer (12) from the clutch shaft (**Figure 17-16, Page 17-12**).
3. Grasp the driven clutch assembly and slide it off the shaft.
4. Leave the key (9) in the keyway (**Figure 17-16, Page 17-12**).

DRIVEN CLUTCH DISASSEMBLY

1. Using external snap ring pliers, remove the retaining ring (4) (**Figure 17-17, Page 17-14**). **See following WARNING.**

▲ WARNING

- **Do not place fingers under the cam when removing the cam. The moveable face may spin when the cam buttons release from the cam ramps, resulting in severe personal injury.**
2. Insert a puller plug (CCI 1014507) (**Figure 17-18, Page 17-14**) into the shaft bore and use a driven clutch cam puller (CCI 1014508) to remove the cam (4) from the fixed face shaft (8) (**Figure 17-16, Page 17-12**).
 3. Remove the spring (5) (**Figure 17-16, Page 17-12**).
 4. Retain the key (3).
 5. Slide the moveable face (7) off the fixed face shaft (8) (**Figure 17-16, Page 17-12**).

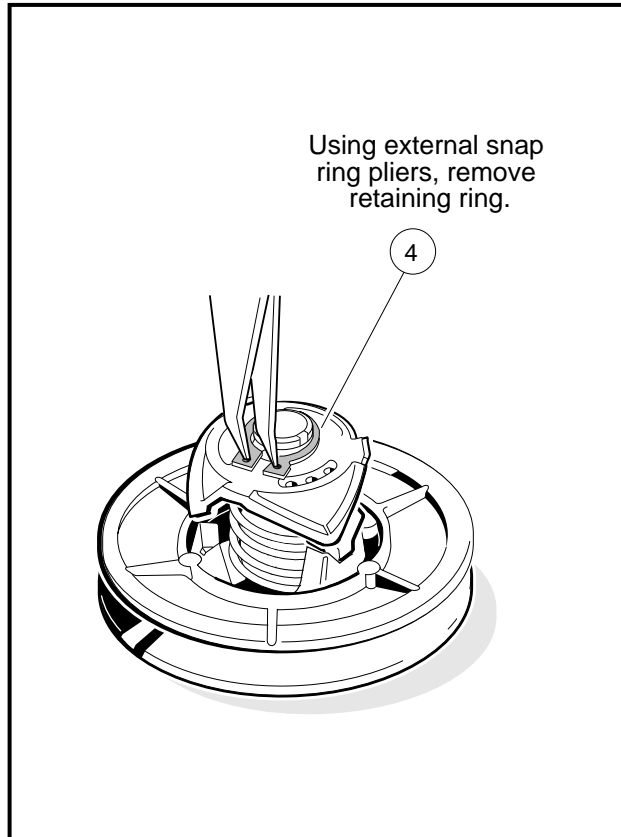

Figure 17-17 Remove Retaining Ring

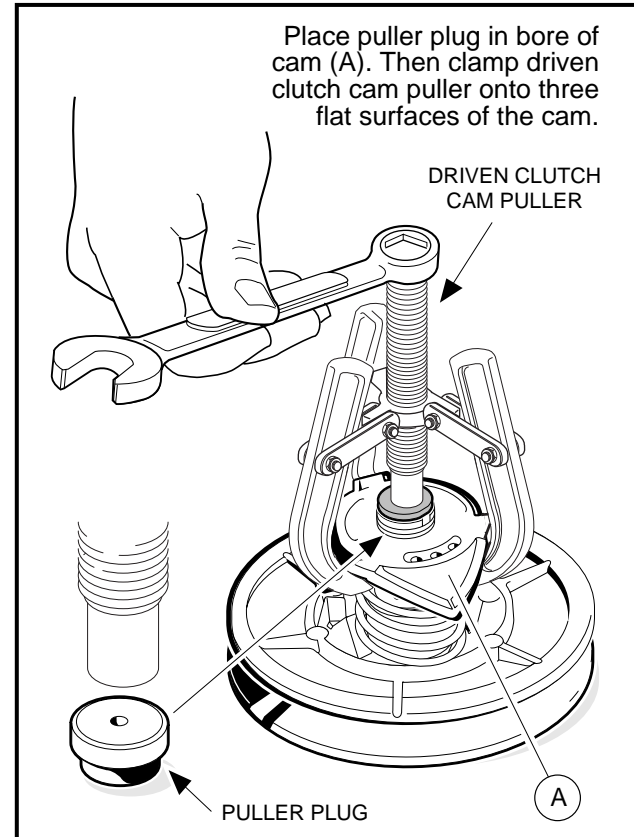

Figure 17-18 Driven Clutch Disassembly

DRIVEN CLUTCH INSPECTION

1. Inspect the cam (4) for excessive wear. Replace it if necessary (**Figure 17-16, Page 17-12**).
2. Inspect the drive buttons (6) for excessive wear. Replace if necessary. To remove the drive buttons, remove the socket head cap screws and then the buttons (**Figure 17-16, Page 17-12**).
3. Inspect the smooth surface on the fixed and moveable face assemblies. Assemblies must be replaced if surfaces are worn more than 0.060 inch (1.5 mm).
4. Inspect the bronze bearing in the moveable face. If the bearing bore diameter is more than 1.384 inches (35.15 mm), the entire moveable face assembly must be replaced.
5. Inspect the shaft of the fixed face assembly. There should be no measurable wear. Replace the shaft if it is worn, scratched or damaged.

DRIVEN CLUTCH ASSEMBLY

1. Place the three drive buttons (6) in position. Apply one drop of Loctite® 222 to each of the socket head cap screws and then install and tighten them to 8 in-lb (0.9 N·m) (**Figure 17-16, Page 17-12**).
2. Slide the moveable face assembly (7) onto the fixed face shaft (8).
3. Place the end of the spring (5) into the hole in the moveable face assembly.
4. Install the key (3) into the keyway of the fixed face assembly (8) shaft.
5. Holding the cam (4) in position for assembly on the shaft, install the other end of the spring (5) into the center spring hole of the cam. Rotate the cam until the keyway is aligned with the key (3) on the fixed face assembly, and then start the cam onto the shaft approximately 1/4 to 3/8 inch (6.3 to 9.5 mm).

6. Place the clutch assembly in a press and position the cam press tool (CCI 101809101) on the cam as shown (**Figure 17-19, Page 17-15**).
7. Hold the fixed face assembly (3) and rotate the moveable face assembly (1) one-third turn **clockwise**, then press the cam (2) onto the fixed face assembly (**Figure 17-19, Page 17-15**).
8. Install the retaining ring (2) (**Figure 17-16, Page 17-12**). **See following NOTE.**

NOTE: The retaining ring can be reused if the O.D. does not exceed 1.607 inches (40.82 mm). Otherwise it must be replaced with a new ring (CCI 1014080).

9. While holding onto the cam, tap the end of the fixed face shaft lightly with a plastic mallet until the cam seats against the retaining ring. **See following CAUTION.**

▲ CAUTION

- Do not use a metal hammer to tap the fixed face hub. A metal hammer will damage the shaft.

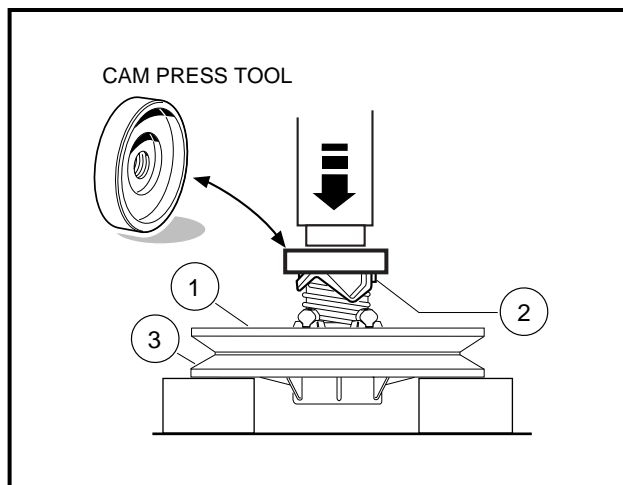

Figure 17-19 Cam Press Tool

DRIVEN CLUTCH INSTALLATION

1. To install the driven clutch, reverse the removal procedure. Before tightening the center bolt (11) to 14 ft-lb (19.0 N·m), make sure the mounting washer (12) is installed between the center bolt and the clutch (yellow side facing out) (**Figure 17-16, Page 17-12**).

A**a-arm**

see suspension, front

accelerator

cable

installation 14-13

removal 14-11

pedal

adjustment 5-3

installation 5-9

removal 5-8

rod

adjustment 5-4, 14-9

installation 14-9

removal 14-9

ACR valve

inspection 13-26

air box

installation 14-15

removal 14-15

air filter 14-18

replacement 14-18

armature

see starter/generator

armrest

installation 4-8

removal 4-7

automatic compression release valve

see ACR valve

axle

bearing

installation 16-6

removal 16-5

shaft

installation 16-7

oil seal 16-4

removal 16-4

axle shaft 16-3**B****ball bearing**

installation 13-4

battery 12-31

charging 12-34, 12-36

hydrometer test 11-22

installation 12-35

load test 11-23

maintenance 12-32

mineral content 12-33

removal 12-33

self-discharge 12-32

storage 12-35

testing 11-21, 11-39

vibration damage 12-33

voltage test 11-23

water level 12-32

bed, tilt

see tilt bed

bell crank

see brakes, bell crank

belt, drive

see drive belt

bleeding, brake system 6-29**body, front**

components 4-3

installation 4-5

removal 4-3

repair 4-2

boring, engine 13-30, 13-51**brakes**

adjuster

installation 6-22

removal 6-21

bell crank

replacement 6-26

bleeding, hydraulic system 6-29

brake fluid 10-6

cluster

inspection and cleaning 6-4, 6-10

replacement 6-17

drum/hub

inspection 6-4, 7-20

installation 6-14

removal 6-7

hydraulic system, purging 6-30

line and hose

inspection 6-3

replacement 6-24

master cylinder

see master cylinder

park brake

see park brake

pedal

adjustment 5-1

inspection 6-2

installation 5-8

removal 5-7

shoe

inspection 6-4

installation 6-12

removal 6-9

system inspection 6-2

troubleshooting 6-4

- wheel cylinder
 - installation 6-21
 - removal 6-20
- breather valve (reed valve)**
 - function 13-12, 13-20
 - inspection 13-20
 - installation 13-20
 - removal 13-12
- brush guard**
 - installation 4-2
 - removal 4-2
- bumper**
 - see brush guard
- C**
- camshaft**
 - axial play adjustment 13-46
 - inspection 13-25
 - installation 13-45
 - removal 13-25
- carburetor**
 - choke and fresh air system 14-4
 - closed throttle or idle adjustment 14-13
 - float system 14-4
 - function 14-1
 - jet, main 14-5
 - elevation/size chart 14-5
 - main system 14-2
 - slow speed system 14-2
 - troubleshooting 14-4
- cargo bed**
 - see tilt bed
- CAUTION**
 - definition of 1-1
- choke**
 - cable
 - installation 14-14
 - removal 14-14
 - choke and air intake system 14-4, 14-14
- cleaning**
 - brake cluster 6-10
 - seat 4-5
 - vehicle 4-1
- clutch (torque converter) troubleshooting** 17-3
- clutch, drive**
 - see drive clutch
- clutch, driven**
 - see driven clutch
- column, steering**
 - see steering column
- commutator**
 - see starter/generator
- connecting rod**
 - inspection 13-29
 - installation 13-44
 - removal 13-27
 - separation from piston 13-27
 - undersized 13-40
- counterbalance**
 - disassembly 13-36
 - guide shaft inspection 13-38
 - removal 13-35
- counterbalance weight**
 - bearing replacement 13-38
 - inspection 13-38
- crankcase cover**
 - ball bearing
 - inspection 13-41
 - removal 13-41
 - installation 13-47
 - oil seal
 - installation 13-42
 - removal 13-42
 - removal 13-24
- crankshaft**
 - axial play adjustment 13-44
 - disassembly 13-36
 - inspection 13-39
 - installation 13-43
 - removal 13-35
- cylinder block**
 - inspection 13-30
- cylinder bore**
 - resizing cylinder bore 13-51
- cylinder head**
 - cleaning and inspection 13-12
 - installation 13-19
 - removal 13-10
- D**
- DANGER**
 - definition of 1-1
- dash panel** 4-3
- dashboard**
 - installation 4-3
 - removal 4-3
- diagram, schematic** 11-6
- differential**
 - see unitized transaxle
- differential gear case**
 - assembly 16-29
 - disassembly 16-22

- differential lock**
 cable
 installation 16-51
 removal 16-49
 differential lock housing 16-19, 16-31
 differential lock lever 16-2
 system inspection 16-49
- diode**
 installation 12-15
 removal 12-14
 testing 11-30
- diode, headlight**
 installation 12-30
 removal 12-30
 testing 11-42
- drive belt**
 inspection 17-3
 installation 17-4
 removal 17-3
- drive clutch**
 assembly 17-9
 cleaning and inspection 17-5, 17-9
 disassembly 17-7
 installation 17-13
 operation 17-1
 removal 17-4
- drive unit**
 see unitized transaxle
- driven clutch**
 assembly 17-14
 disassembly 17-13
 inspection 17-14
 installation 17-15
 operation 17-1
 removal 17-13
- E**
- electrical system** 13-4
 circuits 11-8
 electrical testing 11-14
 engine ignition circuit 11-10, 11-16
 engine kill circuit 11-10, 11-16
 fuel gauge/sending unit circuit 11-13, 11-19
 generator circuit 11-9
 headlights 11-20
 hour gauge circuit 11-14
 lighting circuit 11-14
 lockout cam circuit 11-12, 11-19
 see also lockout cam
 low oil warning circuit 11-12, 11-18
 reverse buzzer circuit 11-11, 11-17
 starter and generator circuit 11-15
 starter circuit 11-9
- engine**
 assembly 13-48
 boring 13-30, 13-51
 ignition circuit 11-10
 removal 13-23
 rotation 13-4
 RPM adjustment 14-13
 service specifications 13-50
- engine oil** 10-6
- exhaust system** 15-1
- F**
- fender**
 front
 installation 4-5
 removal 4-5
 rear
 installation 4-10
 removal 4-10
- field coil**
 see starter/generator
- floor mat**
 removal and installation 4-12
- fluid, brake** 10-6
- flywheel**
 installation
 see engine assembly
 removal 13-31
- forward/reverse**
 cable
 adjustment 16-48
 installation 16-47
 removal 16-47
 handle (lever) 16-2
- front body**
 see body, front
- fuel filter**
 installation 14-19
 maintenance 14-19
 removal 14-19
- fuel gauge**
 see fuel/hour gauge
- fuel gauge sending unit circuit**
 operation 11-13
 troubleshooting 11-19
- fuel level sending unit** 12-24
 testing 11-39
- fuel lines** 14-27
- fuel pump**
 assembly 14-22
 cleaning and inspection 14-22

- disassembly 14-21
- installation 14-23
- maintenance 14-21
- removal 14-21
- fuel shut-off valve** 14-28
- fuel tank**
 - disposal 14-25
 - installation 14-25
 - removal 14-24
 - storage 14-25
- fuel/hour gauge**
 - fuel gauge circuit 11-13
 - testing 11-40
 - fuel level sending unit 12-24
 - testing 11-39
 - hour gauge circuit 11-14
 - testing 11-41
 - installation 12-24
 - operation 12-23
 - removal 12-23
- fueling instructions** 10-7
- fuse**
 - installation 12-18
 - removal 12-18
 - testing 11-24
- G**
- generator circuit**
 - operation 11-9
 - troubleshooting 11-15
- governor**
 - gear 16-21
 - gear assembly 16-31
 - governor system 16-3
- governor cable**
 - installation and adjustment 14-10
 - removal 14-10
- ground straps**
 - testing 11-24
- H**
- headlight bulb**
 - installation 12-29
 - removal 12-29
- headlight diode**
 - see diode, headlight
- headlight switch**
 - installation 12-31
 - removal 12-31
 - testing 11-41
- headlights**
 - see also lighting circuit
 - testing 11-43
- hitch, receiver**
 - see receiver hitch
- hour gauge**
 - see fuel/hour gauge
- hub, front wheel**
 - see brakes, drum/hub
- hydraulic lifters**
 - function 13-6
 - inspection 13-25
 - removal 13-25
- hydrometer test** 11-22
- I**
- idler shaft**
 - assembly 16-26
 - disassembly 16-24
- ignition**
 - testing 11-33
- ignition coil**
 - installation 12-27, 13-32
 - removal 12-25, 13-31
 - testing 11-35
- inspection**
 - brake cluster 6-4
 - inspection and cleaning 6-10
 - brake drum 6-4
 - brake line and hose 6-3
 - brake pedal 6-2
 - brake shoe 6-4
 - breather valve 13-20
 - camshaft 13-25
 - connecting rod 13-29
 - counterbalance guide shaft 13-38
 - counterbalance weight 13-38
 - crankcase cover ball bearing 13-41
 - crankshaft 13-39
 - cylinder head 13-12
 - differential lock 16-49
 - drive clutch 17-5
 - drive clutch parts 17-9
 - driven clutch 17-14
 - fuel pump 14-22
 - hydraulic lifters 13-25
 - link rod 13-37
 - master cylinder 6-3
 - oil pressure relief valve 13-34
 - oil pump 13-33
 - park brake 6-3
 - piston 13-27
 - piston pin 13-29
 - pre-operation safety checklist (daily) 10-2

- push rod 13-19
 rocker arm 13-18
 rocker shaft 13-18
 spark plug 13-7
 starter/generator
 armature 12-8
 bearing 12-6
 brush spring 12-4
 brushes 12-3
 commutator 12-8
 field coils 12-9
 unitized transaxle components 16-26
 valve guide 13-13
 valve seat 13-13
 valve spring 13-18
 valves, intake and exhaust 13-16
- intake duct**
 installation 14-16
 removal 14-15
 repair 14-18
- intermediate gear**
 assembly 16-26
 disassembly 16-24
- K**
- key switch**
 engine kill circuit testing 11-36
 installation 12-16
 removal 12-15
 starter circuit testing (pedal-start) 11-26
- kill circuit, engine**
 operation 11-10
 testing 11-16, 11-32, 11-37
- L**
- leaf spring, rear**
 installation 9-4
 removal 9-3
- lighting circuit**
 operation 11-14
 troubleshooting 11-20
- link rod**
 inspection 13-37
- lockout cam**
 function 16-2
 installation 12-20
 limit switch 11-28
 installation 12-19
 removal 12-18
 removal 12-20
 testing 11-38
 troubleshooting 11-19
- lockout cam circuit**
 function 11-12
- low oil warning circuit**
 function 11-12
 troubleshooting 11-18
- low oil warning light**
 installation 12-23
 removal 12-23
 testing 11-38
- lubrication**
 FE350 engine 13-3
 front suspension 7-13
 lubricant 13-3
 lubrication system 13-5
 periodic lubrication schedule 10-4
- M**
- maintenance**
 battery 12-32
 periodic lubrication schedule 10-4
 periodic service schedule 10-3
- master cylinder**
 inspection 6-3
 installation 6-28
 removal 6-28
- muffler**
see also exhaust system
 installation 15-2
 removal 15-2
- multi-leaf spring**
see leaf spring
- N**
- neutral lockout**
see lockout cam
- O**
- oil level sensor**
 installation 13-24
 removal 13-24
 testing 11-38
- oil light**
see low oil warning light
- oil pressure relief valve**
 inspection 13-34
 installation 13-34
 removal 13-34
- oil pump**
 cover removal 13-32
 inspection 13-33
 installation 13-35

- oil screen**
installation 13-40
removal 13-40
- oil, engine** 10-6
- P**
- park brake**
adjustment 6-34
equalizer cable installation 6-33
handle
installation 6-34
removal 6-33
inspection 6-3
wheel cable
installation 6-33
removal 6-33
- pedal, accelerator**
see accelerator
- pedal, brake**
see brakes
- periodic lubrication schedule** 10-4
- periodic service schedule** 10-3
- piston**
boring the engine 13-30, 13-51
inspection and repair 13-27
installation 13-44
pin inspection 13-29
removal 13-27
ring inspection 13-28
separation from connecting rod 13-27
- push rod**
inspection 13-19
removal 13-10
- R**
- rack and pinion**
assembly 7-10
disassembly 7-8
installation 7-13
removal 7-6
- receiver hitch**
removal and installation 4-10
- reed valve**
see breather valve
- reverse buzzer**
installation 12-20
limit switch
installation 12-21
removal 12-21
testing 11-37
removal 12-20
testing 11-37
- reverse buzzer circuit**
operation 11-11
troubleshooting 11-17
- ring, piston**
see piston
- rocker arm**
inspection 13-18
removal 13-10
- rocker shaft**
inspection 13-18
- RPM adjustment** 14-13
- RPM limiter**
installation 12-25
removal 12-24
testing 11-34
- S**
- safety** 1-1
daily pre-operation safety checklist 10-2
- schematic diagram** 11-6
- seat**
adjustment 4-6
armrest
installation 4-8
removal 4-7
cleaning 4-5
removal 4-5
seat support
installation 4-6
removal 4-6
- serial number, vehicle** 3-1
- service schedule**
see periodic service schedule
- service tools**
engine 13-2
torque converter kit 17-2
unitized transaxle 16-3
- shifter fork, unitized transaxle**
assembly 16-29
disassembly 16-23
- shock absorber**
front
inspection 7-18
installation 7-19
removal 7-18
rear
inspection 9-1
installation 9-3
removal 9-1
- snuubber**
installation 9-5
removal 9-5

solenoid	
installation	12-17
removal	12-17
testing	11-27
spark plug	
cleaning, inspection and repair	13-7
gap adjustment	13-6, 13-8
installation	13-8
removal	13-7
testing	13-7
specifications	
engine service	13-50
resizing cylinder bore	13-51
torque	13-51
vehicle	2-1
spring, multi-leaf	
see leaf spring	
starter/generator	
armature	12-6
ground test	12-9
inspection	12-8
assembly	12-4, 12-10
bearing	
cleaning	12-6
inspection	12-6
removal	12-7
belt tension adjustment	12-12
brush spring	
inspection	12-4
replacement	12-4
brushes	12-3
inspection	12-3
replacement	12-3
commutator	12-6
cleaning	12-8
inspection	12-8
disassembly	12-3, 12-6
field coil	
inspection	12-9
removal	12-7
installation	12-11
removal	12-2
rework	12-10
testing	11-29, 11-31
steering	
rack and pinion	
assembly	7-10
disassembly	7-8
installation	7-13
removal	7-6
steering column	
assembly	7-5
disassembly	7-4
installation	7-6
removal	7-4
steering wheel	
installation	7-3
removal	7-1
storage (vehicle)	3-1
suspension	
snubber	
installation	9-5
removal	9-5
suspension, front	
a-arm	
installation	7-18
removal	7-17
kingpin and steering spindle	
installation	7-17
removal	7-16
lubrication	7-13
shock absorber	
inspection	7-18
installation	7-19
removal	7-18
toe-in adjustment	7-14
wheel alignment	7-14
wheel bearings and hubs	7-20
suspension, rear	
leaf spring	
installation	9-4
removal	9-3
shock absorber	
inspection	9-1
installation	9-3
removal	9-1
synchronizer gear	16-23, 16-26
T	
tailskirt	
removal and installation	4-10
test procedure	
battery	11-21, 11-39
diode	11-30
engine kill circuit	11-32, 11-37
fuel gauge	11-40
fuel level sending unit	11-39
fuse	11-24
ground straps	11-24
headlight	11-43
headlight diode	11-42
headlight switch	11-41
hour gauge	11-41
ignition coil	11-35

- ignition test 11-33
- key switch
- engine kill circuit 11-36
 - starter circuit (pedal-start) 11-26
- lockout cam
- cam 11-38
 - limit switch 11-28
- low oil warning light 11-38
- oil level sensor 11-38
- reverse buzzer 11-37
- reverse buzzer limit switch 11-37
- RPM limiter 11-34
- solenoid 11-27
- starter/generator 11-29, 11-31
- voltage regulator 11-32
- wire continuity 11-30
- test procedures, index of** 11-20
- testing**
- circuit testing 11-14
 - engine ignition circuit 11-16
 - engine kill circuit 11-16
 - fuel gauge/sending unit circuit 11-19
 - headlights 11-20
 - lockout cam circuit 11-19
 - reverse buzzer circuit 11-17
 - spark plug 13-7
 - starter circuit and generator circuit 11-15
 - starter/generator
 - armature ground test 12-9
- tilt bed**
- bumper adjustment 4-8
 - installation 4-8
 - removal 4-8
- tire**
- installation 8-3
 - pressure 8-1
 - removal 8-3
 - repair 8-3
- tools**
- see service tools
- torque converter**
- operation 17-1
 - troubleshooting 17-3
- transaxle**
- see unitized transaxle
- troubleshooting**
- see also testing
 - brake system 6-4
 - torque converter 17-3
 - vehicle troubleshooting guide 11-2
- U**
- unitized transaxle**
- assembly 16-32
 - disassembly 16-15
 - inspection of components 16-26
 - installation 16-39
 - lubrication 16-3
 - operation 16-1
 - removal 16-7
 - service 16-3
- V**
- valve guide**
- inspection 13-13
 - replacement 13-13
- valve seat**
- inspection 13-13
 - repair 13-14
- valve spring**
- inspection 13-18
- valve, automatic compression release**
- see ACR valve
- valve, intake and exhaust**
- inspection 13-16
 - removal 13-11
- voltage limiter**
- see diode, headlight
- voltage regulator**
- installation 12-14
 - removal 12-13
 - testing 11-32
- W**
- WARNING**
- definition of 1-1
- wheel**
- see also tire
 - installation 8-2
 - removal 8-2
- wheel bearings and hub**
- see brakes, drum/hub
- wheel cylinder**
- see brakes, wheel cylinder
- wire continuity testing** 11-30
- wiring diagram** 11-6



Club CarTM
Performance Utility Vehicles

Club Car, Inc.
P.O. Box 204658
Augusta, GA 30917-4658
USA

Web www.clubcar.com
Phone 1.706.863.3000
1.800.ClubCar
Int'l +1 706.863.3000
Fax 1.706.863.5808