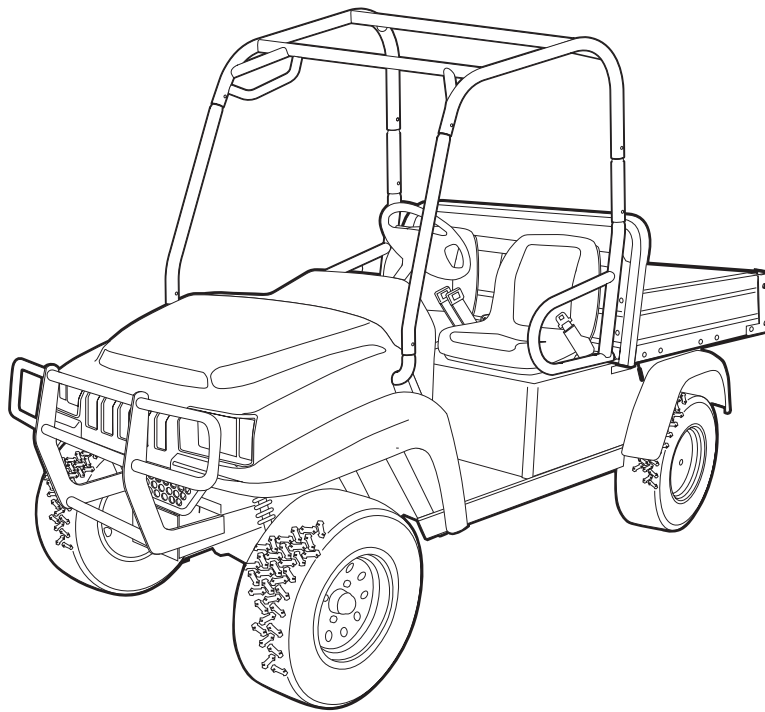




**2006-2010 Turf/Carryall  
272/472, XRT1200/SE  
Maintenance and Service  
Manual**



**Turf 272, Carryall 272, Carryall 472,  
XRT 1200, and XRT1200 SE  
Gasoline Vehicles**

Manual Number 102907711  
Edition Code 1007B0810A



## FOREWORD

---

Club Car vehicles are designed and built to provide the ultimate in performance efficiency; however, proper maintenance and repair are essential for achieving maximum service life and continued safe and reliable operation.

This manual provides detailed information for the maintenance and repair of the Turf/Carryall 272/472 and XRT 1200/1200 SE vehicles, and should be thoroughly reviewed prior to servicing the vehicles. The procedures provided must be properly implemented, and the DANGER, WARNING, and CAUTION statements must be heeded.

This manual was written for the trained technician who already possesses knowledge and skills in electrical and mechanical repair. If the technician does not have such knowledge and skills, attempted service or repairs to the vehicle may render the vehicle unsafe. For this reason, Club Car advises that all repairs and/or service be performed by an authorized Club Car distributor/dealer representative or by a Club Car factory-trained technician.

It is the policy of Club Car, LLC to assist its distributors and dealers in continually updating their service knowledge and facilities so they can provide prompt and efficient service for vehicle owners. Regional technical representatives, vehicle service seminars, periodic service bulletins, maintenance and service manuals, and other service publications also represent Club Car's continuing commitment to customer support.

Club Car offers a full line of training and continuing education classes for technicians who want to learn more about our products. For more information, contact your local dealer or Club Car's Technical Services department for a list of upcoming classes.

This manual covers all aspects of typical vehicle service; unique situations, however, sometimes occur when servicing a vehicle. If it appears that a service question is not answered in this manual, you may write to us at: Club Car, LLC, P.O. Box 204658; Augusta, GA 30917, Attention: Technical Services.

Copyright © 2006, 2007, 2010 Club Car, LLC  
*Club Car* and *Carryall*  
are registered trademarks of Club Car, LLC.  
This manual effective July 25, 2005.

## **WARNING**

- **Read Section 1 – Safety before attempting any service on this vehicle.**
- **Before servicing vehicle, read complete section(s) and any referenced information that may be relevant to the service or repair to be performed.**

**NOTE:** *This manual represents the most current information at the time of publication. Club Car, LLC, is continually working to further improve its vehicles and other products. These improvements may affect servicing procedures. Any modification and/or significant change in specifications or procedures will be forwarded to all Club Car dealers and will, when applicable, appear in future editions of this manual.*

*Damage to a vehicle or component thereof not resulting from a defect or that occurs due to unreasonable or unintended use, overloading, abuse, or neglect (including failure to provide reasonable or necessary maintenance as instructed in the vehicle owner's manual), accident or alteration, including increasing vehicle speed beyond factory specifications or modifications that affect the stability of the vehicle or the operation thereof, will void the warranty.*

*Club Car, LLC, reserves the right to change specifications and designs at any time without notice and without incurring any obligation or liability whatsoever.*

*There are no warranties expressed or implied in this manual. See the limited warranty found in the vehicle owner's manual or write to Club Car, LLC, P.O. Box 204658, Augusta, Georgia 30917-4658 USA, Attention: Warranty Department.*

# CONTENTS

---

## SECTION 1 – SAFETY

---

General Warning .....	1-1
Disabling The Vehicle .....	1-3
Disconnecting The Battery .....	1-3
Connecting The Battery .....	1-3

## SECTION 2 – VEHICLE SPECIFICATIONS

---

General Information .....	2-1
---------------------------	-----

## SECTION 3 – GENERAL INFORMATION

---

General Information .....	3-1
Engine Identification .....	3-1
Serial Number Identification .....	3-1
Storage .....	3-2
Preparing The Vehicle For Extended Storage .....	3-2
To Return Vehicle To Service .....	3-3

## SECTION 4 – BODY AND TRIM

---

Cleaning the Vehicle .....	4-1
Front Body Repair .....	4-2
Abrasions and Haze .....	4-2
Light Scratches .....	4-2
Large Scratches and Abrasions .....	4-2
Tube Bumper/Brush Guard .....	4-2
Tube Bumper/Brush Guard Removal .....	4-2
Tube Bumper/Brush Guard Installation .....	4-2
Front Body Components .....	4-3
Dashboard Removal .....	4-3
Dashboard Installation .....	4-3
Front Body Removal .....	4-5
Front Fender Removal .....	4-5
Front Fender Installation .....	4-5
Front Body Installation .....	4-5
Seat .....	4-5
Seat Adjustment .....	4-7

Front Seat Support .....	4-7
Front Seat Support Removal .....	4-7
Front Seat Support Installation .....	4-7
Rear Seat Support .....	4-9
Rear Seat Support Removal (Carryall 472/XRT 1200 SE) .....	4-9
Rear Seat Support Installation (Carryall 472/XRT 1200 SE) .....	4-9
Cargo Bed .....	4-11
Cargo Bed Removal .....	4-11
Cargo Bed Installation .....	4-11
Bed Stop Bumper Adjustment .....	4-13
Rear Fender .....	4-14
Rear Fender Removal .....	4-14
Rear Fender Installation .....	4-14
Tailskirt .....	4-14
Tailskirt Removal .....	4-14
Tailskirt Installation .....	4-14
Trailer Hitch .....	4-15
Trailer Hitch Removal .....	4-15
Trailer Hitch Installation .....	4-15
Receiver Hitch .....	4-15
Receiver Hitch Removal .....	4-15
Receiver Hitch Installation .....	4-15
Floor Mat .....	4-18
Floor Mat Removal .....	4-18
Floor Mat Installation .....	4-18

## **SECTION 5 – ACCELERATOR AND BRAKE PEDAL ASSEMBLIES**

---

Brake Pedal .....	5-1
Brake Pedal Removal .....	5-1
Brake Pedal Installation .....	5-1
Brake Pedal Adjustment .....	5-3
Accelerator Pedal .....	5-5
Accelerator Pedal Removal .....	5-5
Accelerator Pedal Installation .....	5-5
Accelerator Pedal Adjustment .....	5-6

## **SECTION 6 – MC012C-BS00 TRANSAXLE: HYDRAULIC AND PARK BRAKE SYSTEMS**

---

Brake System Inspection .....	6-1
Brake System Troubleshooting .....	6-3

Brake Drum Removal .....	6-6
Front Wheel Brake Drum Removal .....	6-6
Rear Wheel Brake Drum Removal .....	6-8
Brake Shoe Removal .....	6-8
Front Brake Shoe Removal .....	6-8
Rear Brake Shoe Removal .....	6-8
Brake Cluster Inspection and Cleaning .....	6-10
Brake Shoe Installation .....	6-11
Front Brake Shoe Installation .....	6-12
Rear Brake Shoe Installation .....	6-12
Brake Drum Installation .....	6-14
Front Wheel Brake Drum Installation .....	6-14
Rear Wheel Brake Drum Installation .....	6-16
Brake Cluster Assembly Replacement .....	6-17
Front Brake Cluster Assembly Removal .....	6-17
Front Brake Cluster Assembly Installation .....	6-17
Rear Brake Cluster Assembly Removal .....	6-18
Rear Brake Cluster Assembly Installation .....	6-19
Wheel Cylinder Replacement .....	6-19
Front Wheel Cylinder Removal .....	6-19
Front Wheel Cylinder Installation .....	6-20
Rear Wheel Cylinder Removal .....	6-20
Rear Wheel Cylinder Installation .....	6-20
Brake Shoe Adjuster Replacement .....	6-21
Front Brake Shoe Adjuster Removal .....	6-22
Front Brake Shoe Adjuster Installation .....	6-22
Rear Brake Shoe Adjuster Removal .....	6-22
Rear Brake Shoe Adjuster Installation .....	6-22
Hydraulic Line and Hose Replacement .....	6-23
Front Brake Line Removal .....	6-23
Front Brake Line Installation .....	6-23
Front Brake Hose Assembly Removal .....	6-24
Front Brake Hose Assembly Installation .....	6-24
Rear Brake Line Removal .....	6-24
Rear Brake Line Installation .....	6-25
Rear Brake Hose Removal .....	6-25
Rear Brake Hose Installation .....	6-28

Master Cylinder and Bell Crank Replacement .....	6-28
Bell Crank Removal .....	6-28
Bell Crank Installation .....	6-28
Master Cylinder Removal .....	6-28
Master Cylinder Installation .....	6-29
Bleeding the Hydraulic Brake System .....	6-31
Purging the Hydraulic System .....	6-32
Filling the Hydraulic System .....	6-32
Park Brake System .....	6-33
Park Brake Cable Removal .....	6-33
Park Brake Cable Installation .....	6-34
Park Brake Handle Removal .....	6-35
Park Brake Handle Installation .....	6-35
Park Brake Adjustment .....	6-35

**SECTION 7 – STEERING AND FRONT SUSPENSION**

---

Steering Wheel .....	7-1
Steering Wheel Removal .....	7-1
Steering Wheel Installation .....	7-3
Steering Column .....	7-3
Steering Column Removal .....	7-3
Steering Column Disassembly .....	7-3
Steering Column Assembly .....	7-4
Steering Column Installation .....	7-5
Rack and Pinion .....	7-6
Rack and Pinion Inspection .....	7-6
Rack and Pinion Removal .....	7-6
Rack and Pinion Disassembly .....	7-7
Rack and Pinion Assembly .....	7-11
Rack and Pinion Installation .....	7-12
Front Suspension .....	7-13
Lubrication .....	7-13
Wheel Alignment .....	7-13
Front Suspension Components .....	7-14
Kingpin and Steering Spindle Removal .....	7-14
Kingpin and Steering Spindle Installation .....	7-15
A-Arm Removal .....	7-16
A-Arm Installation .....	7-16
Shock Absorber Removal .....	7-18
Shock Absorber Installation .....	7-18



Front Wheel Bearings and Hubs .....	7-19
Front Wheel Free Play Inspection .....	7-19
Front Wheel Bearings and Hub Removal .....	7-19
Front Wheel Bearings and Hub Installation .....	7-19

## **SECTION 8 – WHEELS AND TIRES**

---

General Information .....	8-1
---------------------------	-----

## **SECTION 9 – REAR SUSPENSION**

---

Shock Absorbers .....	9-1
Shock Absorber Removal and Inspection .....	9-1
Shock Absorber Installation .....	9-1
Multi-Leaf Springs .....	9-1
Multi-Leaf Spring Removal .....	9-1
Multi-Leaf Spring Installation .....	9-3
Snubber .....	9-4
Snubber Removal .....	9-4
Snubber Installation .....	9-4

## **SECTION 10 – PERIODIC MAINTENANCE**

---

Periodic Service Schedule .....	10-1
Periodic Lubrication Schedule .....	<b>10-3</b>
Master Cylinder .....	10-4
Brake Fluid .....	10-4
Engine Oil .....	10-4
Engine Oil Level Check .....	10-4
Engine Oil And Filter Change .....	10-5
Oil Viscosity .....	10-8
Fueling Instructions .....	10-8
Battery .....	10-10

## **SECTION 11 – TROUBLESHOOTING AND ELECTRICAL SYSTEM: FE400, KEY-START ENGINE**

---

Troubleshooting Guide .....	11-1
Electrical System .....	11-5
Lockout Cam .....	11-5
Circuit Testing .....	11-5
Wiring Diagrams .....	11-6

Test Procedures .....	11-10
Index of Test Procedures .....	11-10

## **SECTION 12 – ELECTRICAL COMPONENTS: FE400, KEY-START ENGINE**

---

Starter/Generator (Model G425419) .....	12-1
Starter/Generator (Model 114-01-4005) .....	12-10
Voltage Regulator .....	12-21
Diode .....	12-22
Key Switch .....	12-24
Solenoid .....	12-25
Fuse .....	12-26
Lockout Cam Limit Switch .....	12-27
Lockout Cam .....	12-28
Reverse Warning Buzzer .....	12-29
Reverse Buzzer Limit Switch .....	12-30
Oil Warning Light .....	12-30
Fuel Gauge/Hour Meter .....	12-31
Fuel Level Sending Unit .....	12-32
RPM Limiter .....	12-33
Ignition Coil .....	12-34
Oil Level Sensor .....	12-37
Headlights .....	12-37
Headlight Diode .....	12-38
Light Switch .....	12-39
Battery .....	12-39
Ground Cables .....	12-44

## **SECTION 13 – FE400 ENGINE**

---

General Information .....	13-1
Before Servicing .....	13-1
Lubrication System .....	13-1
Spark Plug .....	13-2
Cylinder .....	13-3
Breather Valve (Reed Valve) .....	13-3
Valve Clearance Check and Adjustment .....	13-3
Crankcase .....	13-3
Engine Removal .....	13-3
Crankcase Cover Removal .....	13-4
Oil Level Sensor .....	13-5

Ignition Coil and Flywheel .....	13-6
Crankcase Cover Installation .....	13-7
Flywheel Installation .....	13-7
Engine Installation .....	13-8
Torque Specifications .....	13-9
Adjustment and Settings .....	13-9

## **SECTION 14 – FUEL SYSTEM**

---

General Information .....	14-1
Carburetor .....	14-1
Main Jet Elevation/Size Chart .....	14-2
Changing the Main Jet .....	14-2
Engine Control Linkage .....	14-6
General Information .....	14-6
Accelerator Rod .....	14-6
Governor Cable .....	14-7
Accelerator Cable .....	14-8
Closed Throttle or Idle Adjustment .....	14-9
Engine RPM Adjustment .....	14-10
Choke and Air Intake System .....	14-12
Choke Cable Removal .....	14-12
Choke Cable Installation .....	14-12
Air Box Removal .....	14-12
Air Box Installation .....	14-12
Intake Duct Repair .....	14-13
Intake Duct Removal .....	14-13
Intake Duct Installation .....	14-17
Air Filter .....	14-18
Fuel Filters .....	14-18
Fuel Filter Removal .....	14-18
Fuel Filter Installation .....	14-19
Fuel Pump .....	14-19
General Information .....	14-19
Fuel Pump Removal .....	14-19
Fuel Pump Disassembly (Metal Pump Only) .....	14-20
Fuel Pump Cleaning and Inspection (Metal Pump Only) .....	14-21
Fuel Pump Assembly (Metal Pump Only) .....	14-21
Fuel Pump Installation .....	14-21

Fuel Tank .....	14-22
Fuel Tank Removal .....	14-22
Fuel Tank Storage Or Disposal .....	14-26
Fuel Tank Installation .....	14-26
Fuel Lines .....	14-27
Fuel Shut-Off Valve .....	14-28
Carbon Canister (If Equipped) .....	14-28
Carbon Canister Removal .....	14-28
Carbon Canister Installation .....	14-29

## **SECTION 15 – EXHAUST SYSTEM**

---

Muffler .....	15-1
Muffler Removal .....	15-1
Muffler Installation .....	15-1

## **SECTION 16 – MC012C-BS00 UNITIZED TRANSAXLE WITH DIFFERENTIAL LOCK**

---

General Information .....	16-1
Lubrication .....	16-2
Axle Shaft .....	16-3
Axle Shaft, Bearing, and Oil Seal Removal .....	16-3
Axle Shaft, Bearing, and Oil Seal Installation .....	16-5
Unitized Transaxle Removal .....	16-6
Unitized Transaxle Installation .....	16-15
Forward/Reverse Shifter Cable .....	16-23
Forward/Reverse Shifter Cable Removal .....	16-23
Forward/Reverse Shifter Cable Installation .....	16-24
Forward/Reverse Shifter Cable Adjustment .....	16-25
Differential Lock System .....	16-25
Differential Lock System Inspection .....	16-25
Differential Lock Cable Removal .....	16-26
Differential Lock Cable Installation .....	16-26

## **SECTION 17 – TORQUE CONVERTER**

---

General Information .....	17-1
Troubleshooting .....	17-1
Drive Belt .....	17-3
Drive Belt Removal .....	17-3
Drive Belt Installation .....	17-3

Drive Clutch .....	17-4
Drive Clutch Removal .....	17-4
Drive Clutch Cleaning and Inspection .....	17-5
Drive Clutch Disassembly .....	17-6
Inspection of Drive Clutch Parts .....	17-7
Drive Clutch Assembly .....	17-10
Drive Clutch Installation .....	17-11
Driven Clutch .....	17-12
Driven Clutch Removal .....	17-12
Driven Clutch Disassembly .....	17-12
Driven Clutch Inspection .....	17-13
Driven Clutch Assembly .....	17-13
Driven Clutch Installation .....	17-17

**SECTION i – INDEX**

---



# SECTION 1 – SAFETY

---

To ensure the safety of those servicing Club Car vehicles, and to protect the vehicles from damage resulting from improper service or maintenance, the procedures in this manual must be followed. It is important to note that throughout this manual there are statements contained within headings labeled DANGER, WARNING, CAUTION, or NOTE. These special statements relate to specific safety issues, and must be read, understood, and heeded before proceeding.

## **DANGER**

- A DANGER indicates an immediate hazard that will result in severe personal injury or death.

## **WARNING**

- A WARNING with the safety alert symbol indicates an immediate hazard that could result in severe personal injury or death.

## **CAUTION**

- A CAUTION indicates a hazard or unsafe practice that could result in minor personal injury.

## **CAUTION**

- A CAUTION without the safety alert symbol indicates a potentially hazardous situation that could result in property damage.

## **GENERAL WARNING**

---

The following safety procedures must be followed whenever the vehicle is being operated, repaired, or serviced. Service technicians should become familiar with these general statements, which can be found throughout this manual. Also, other specific warnings appear throughout this manual and on the vehicle.

## **DANGER**

- **Battery – Explosive gases! Do not smoke. Keep sparks and flames away from the vehicle and service area. Ventilate when charging or operating vehicle in an enclosed area. Wear a full face shield and rubber gloves when working on or near batteries.**
- **Battery – Poison! Contains acid! Causes severe burns. Avoid contact with skin, eyes, or clothing. Antidotes:**
  - **External: Flush with water. Call a physician immediately.**
  - **Internal: Drink large quantities of milk or water. Follow with milk of magnesia or vegetable oil. Call a physician immediately.**
  - **Eyes: Flush with water for 15 minutes. Call a physician immediately.**
- **Gasoline – Flammable! Explosive! Do not smoke. Keep sparks and flames away from the vehicle and service area. Service only in a well-ventilated area.**
- **Do not operate gasoline vehicle in an enclosed area without proper ventilation. The engine produces carbon monoxide, which is an odorless, deadly poison.**

** WARNING**

- Follow the procedures exactly as stated in this manual, and heed all **DANGER, WARNING, and CAUTION** statements in this manual as well as those on the vehicle.
- Only trained technicians should service or repair the vehicle. Anyone doing even simple repairs or service should have knowledge and experience in electrical and mechanical repair. The appropriate instructions must be used when performing maintenance, service, or accessory installation.

** WARNING**

- Prior to servicing the vehicle or leaving the vehicle unattended, turn the key switch **OFF**, remove the key, and place the Forward/Reverse handle in the **NEUTRAL** position. Chock the wheels when servicing the vehicle.
- To avoid unintentionally starting the vehicle:
  - Disconnect battery cables, negative (–) cable first (Figure 1-1, Page 1-3).
  - Disconnect the spark plug wire from the spark plug.
- Frame ground – Do not allow tools or other metal objects to contact frame when disconnecting battery cables or other electrical wiring. Do not allow a positive wire to touch the vehicle frame, engine, or any other metal component.
- Wear safety glasses or approved eye protection when servicing the vehicle. Wear a full face shield and rubber gloves when working on or near batteries.
- Do not wear loose clothing or jewelry such as rings, watches, chains, etc., when servicing the vehicle.
- Moving parts! Do not attempt to service the vehicle while it is running.
- Hot! Do not attempt to service hot engine or exhaust system. Failure to heed this warning could result in severe burns.
- Use insulated tools when working near batteries or electrical connections. Use extreme caution to avoid shorting of components or wiring.
- Check the vehicle owner's manual for proper location of all vehicle safety and operation decals and make sure they are in place and are easy to read.
- Any modification or change to the vehicle that affects the stability or handling of the vehicle, or increases maximum vehicle speed beyond factory specifications, could result in severe personal injury or death.
- Lift only one end of the vehicle at a time. Use a suitable lifting device (chain hoist or hydraulic floor jack) with 1000 lb. (454 kg) minimum lifting capacity. Do not use lifting device to hold vehicle in raised position. Use approved jack stands of proper weight capacity to support the vehicle and chock the wheels that remain on the floor. When not performing a test or service procedure that requires movement of the wheels, lock the brakes.
- If wires are removed or replaced, make sure wiring and wire harness are properly routed and secured. Failure to properly route and secure wiring could result in vehicle malfunction, property damage, personal injury, or death.
- For vehicles with cargo beds, remove all cargo before raising the bed or servicing the vehicle. If the vehicle is equipped with a prop rod, ensure that it is securely engaged while bed is raised. Do not close bed until all persons are clear of cargo bed area. Keep hands clear of all crush areas. Do not drop cargo bed; lower gently and keep entire body clear. Failure to heed this warning could result in severe personal injury or death.
- Improper use of the vehicle or failure to properly maintain it could result in decreased vehicle performance, severe personal injury, or death.
- Do not leave children unattended on vehicle.



## DISABLING THE VEHICLE

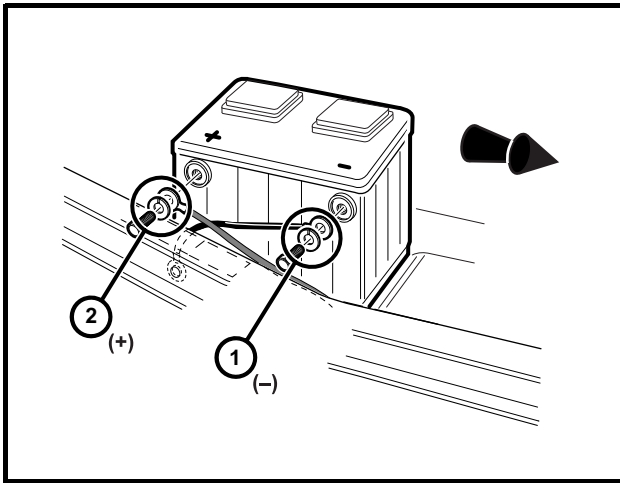
1. Set the park brake.
2. Turn the key switch OFF and remove the key.
3. Place the Forward/Reverse control in the NEUTRAL position.
4. In addition, chock the wheels if servicing or repairing the vehicle.

## DISCONNECTING THE BATTERY

1. Disable the vehicle. **See Disabling The Vehicle on page 1-3.**
2. Disconnect the battery cables, negative (–) cable first, as shown (**Figure 1-1, Page 1-3**).
3. Disconnect the spark plug wire(s) from the spark plug(s).

## CONNECTING THE BATTERY

1. Connect the battery cables, positive (+) cable first.
2. Tighten battery terminals to 80 in-lb (9 N·m).
3. Coat terminals with Battery Terminal Protector Spray (CC P/N 1014305) to minimize corrosion.
4. Connect the spark plug wire(s) to the spark plug(s).



**Figure 1-1 Disconnect Battery – Gasoline Vehicle**

(Viewed from driver side of vehicle)

1. Remove negative battery cable.
  2. Remove positive battery cable.
- Connect battery cables in reverse order.



# SECTION 2 – VEHICLE SPECIFICATIONS

## GENERAL INFORMATION

SPECIFICATIONS	TURF/CA 272	XRT 1200	CARRYALL 472	XRT 1200 SE
<b>POWER SOURCE</b>				
<b>Engine:</b> 4-cycle OHV, 400 cc, 13 maximum hp @ 3600 RPM (per SAE J 1940/1349), single-cylinder, air-cooled with pressure lubrication system	.	.	.	.
<b>Fuel system:</b> Side-draft carburetor with float bowl, fixed jets, fuel filters and impulse fuel pump	.	.	.	.
<b>Governor:</b> Automatic ground-speed sensing internally-gearred in unitized transaxle	.	.	.	.
<b>Ignition:</b> Transistor electronic ignition with electronic RPM limiter	.	.	.	.
<b>Unitized transaxle:</b> Fully synchronized forward and reverse with neutral (14.9:1 forward, 20.5:1 reverse) and differential lock feature	.	.	.	.
<b>Electrical system:</b> 12 volt, 500 cca at 0 °F (-17.8 °C), 650 at 32 °F (0 °C). 105-minute reserve capacity and 35-amp charging capacity	.	.	.	.
<b>Torque converter:</b> Automatic, variable-speed, dry type	.	.	.	.
<b>STEERING/SUSPENSION/BRAKES</b>				
<b>Steering:</b> Self-adjusting rack and pinion, Ackerman	.	.	.	.
<b>Suspension:</b> <b>Front:</b> Independent A-arms with coil-over shocks <b>Rear:</b> Semi-independent suspension with multi-leaf springs and dual hydraulic shocks	.	.	.	.
<b>Brakes:</b> Hydraulic brake system – self-adjusting drum brakes on each wheel with separate hand-operated park brake	.	.	.	.
<b>BODY/CHASSIS</b>				
<b>Frame/Chassis:</b> Twin I-Beam welded aluminum	.	.	.	.
<b>Side and rear body:</b> All aluminum	.	.	.	.
<b>Cargo bed:</b> All aluminum	.	.	.	.
<b>Cargo bed:</b> Powder-coated steel	.	.	.	.
<b>Front body:</b> ABS/DR acrylic cap	.	.	.	.
<b>Tires:</b> 23 x 10.50 - 12 tubeless, 4-ply rated load range, front and rear	.	.	.	.
<b>DIMENSIONS/WEIGHT</b>				
<b>Overall length</b> (with box bed)	120 in. (304.8 cm)		144.4 in. (366.8 cm)	
<b>Overall width</b>	54 in. (137 cm)			
Specifications continued on next page...				

SPECIFICATIONS	TURF/CA 272	XRT 1200	CARRYALL 472	XRT 1200 SE
Overall height (at steering wheel)	51 in. (130 cm)			
Wheelbase	80 in. (203 cm)		101 in. (256 cm)	
Ground clearance: (under differential) (under foot platform)	6.6 in (17 cm) 11.4 in (29 cm)			
Front wheel tread	43 in. (109 cm)			
Rear wheel tread	44.5 in. (113 cm)			
Weight (dry): (with all-terrain tread) (with turf tread)	1100 lb. (499.0 kg) 1060 lb. (480.8 kg)	1106 lb. (499.0 kg) 1066 lb. (480.8 kg)	1200 lb. (544.2 kg) 1160 lb. (526.0 kg)	
Forward speed	17-19 mph (27-31 km/h)			
Governed RPM FE400 engine	3850 (±30) RPM			
Curb clearance circle (diameter)	24 ft. 1 in. (734 cm)		31 ft. 8 in. (965 cm)	
Turning radius (per SAE J 695)	139.6 in. (355 cm)		15 ft. 6 in. (472.4 cm)	
Intersecting aisle clearance	112.2 in. (285 cm)		120 in. (304 cm)	
Floorboard height	17 in. (43 cm)			
Seat height (at seat bottom)	35 in. (89 cm)			
Load bed height	31.1 in. (79 cm)			
Load bed size (box bed inside dimensions)	48.0 x 49.8 x 9.3 in. (121.9 x 126.4 x 24 cm) (13.0 cubic feet)	48.0 x 49.8 x 10.9 in. (121.9 x 126.4 x 27.6 cm) (13.0 cubic feet)	37.6 x 45.1 x 9.3 in. (96 x 115 x 23 cm) (9.13 cubic feet)	
Load bed size (flat bed dimensions)	46.9 x 48.3 in. (119 x 123 cm)		35.8 x 44.3 in. (91 x 112 cm)	
Vehicle rated capacity (level surface only)	1200 lb. (544 kg)		1300 lb. (590 kg)	
Bed load capacity (level surface only)	800 lb. (363 kg)		500 lb. (227 kg)	
Standard seating capacity	2		4	
<b>LIQUID CAPACITIES</b>				
Engine crankcase without filter	32 oz. (.95 liters)			
Engine crankcase with filter	38 oz. (1.12 liters)			
Unitized transaxle	29 oz. (.85 liters)			
Master cylinder	8 oz. (240 ml)			
Fuel tank (unleaded gasoline only)	7 gallons (26.5 liters)		6.5 gallons (24.6 liters)	
<b>TIRE PRESSURE</b>				
All terrain tread (standard)	Front: 7-11 psi (.48-.76 Bars) Rear: 14-18 psi (.97-1.24 Bars)			
Turf tread (optional)	Front: 12-16 psi (.83-1.10 Bars) Rear: 16-20 psi (1.10-1.38 Bars)			
Traks Max II tread (optional)	Front: 14-16 psi (.97-1.10 Bars) Rear: 18-20 psi (1.24-1.38 Bars)			

# SECTION 3 – GENERAL INFORMATION

---

## GENERAL INFORMATION

---

Refer to the owner's manual provided with the vehicle for information on the following topics:

- Vehicle Feature Identification
- Controls and Indicators
- Driving Instructions
- Towing with the Vehicle
- Transporting on a Trailer
- Engine Oil and Filter Change
- Accessory Equipment
- Subsequent Owner Registration
- Warranties

## ENGINE IDENTIFICATION

---

### Read General Warning, Section 1, Page 1-1

Throughout this manual, important vehicle information and features are highlighted. The procedures in this manual apply to vehicles equipped with the standard FE400 engine and key-start with neutral "rev". **See following NOTE.**

***NOTE:** 272 vehicles can be found custom ordered equipped with the non-standard FE350 engine with pedal-start.*

## SERIAL NUMBER IDENTIFICATION

---

The serial number of each vehicle is printed on a bar code decal mounted either below the passenger side cup holder or above the accelerator or brake pedal (Example: PH0901-583947) (**Figure 3-1, Page 3-2**). There is also a second serial number decal mounted on the front body frame behind the dash panel. The dashboard must be removed to view this number.

The two letters (1) at the beginning of the serial number indicate the vehicle model. The following four digits (2) indicate the model year and production week during which the vehicle was built. The six digits (3) following the hyphen represent the unique sequential number assigned to each vehicle built within a given model year. **See following NOTE.**

**NOTE:** Always have the vehicle serial number at hand when ordering parts or making inquiries (Figure 3-1, Page 3-2).



Figure 3-1 Serial Number Decal

## STORAGE

### **⚠ DANGER**

- Read General Warning, Section 1, Page 1-1.

### **⚠ WARNING**

- Read General Warning, Section 1, Page 1-1.

### **⚠ CAUTION**

- Read General Warning, Section 1, Page 1-1.

## PREPARING THE VEHICLE FOR EXTENDED STORAGE

1. Store vehicle in a cool, dry place.
2. Use a 12-volt battery charger rated 10 amps or less to charge battery.
3. Remove all items from the vehicle so that only the vehicle weight will be placed on the tires.
4. Make sure key switch is OFF and the Forward/Reverse handle is in the NEUTRAL position. Chock the wheels.
5. Drain carburetor and seal the fuel tank.
6. Turn the fuel shut-off valve to the closed (OFF) position (Figure 3-4, Page 3-4 and Figure 3-5, Page 3-4) and run the engine until it stalls. See **DANGER** “Do not operate gasoline vehicle...” in General Warning, Section 1, Page 1-1.
7. Disconnect battery and spark plug wire(s). See **Disconnecting The Battery** on page 1-3.
8. Loosen the carburetor drain screw and drain fuel in bowl into a small, clean container and pour the fuel into the vehicle tank. Tighten the carburetor drain screw.
9. Fill fuel tank to about 1 inch (2.5 cm) from top of fuel tank and add a commercially available fuel stabilizer (such as Sta-Bil®).
10. Disconnect vent tube from fuel tank vent (Figure 3-2, Page 3-3 or Figure 3-3, Page 3-3).

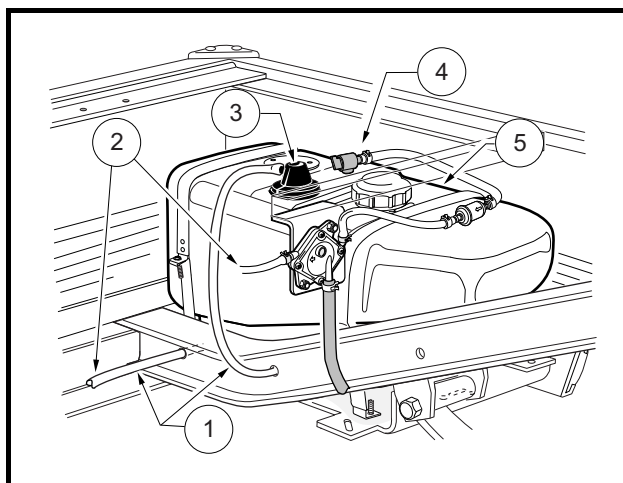
11. Plug the fuel tank vent nipple so that it is air tight using a slip-on vinyl cap.
12. Wash tops and terminals of battery with a solution of baking soda and water (1 cup (237 mL) baking soda per 1 gallon (3.8 L) of water). Rinse solution off battery. Do not allow this solution to enter the battery.
13. Remove spark plug and pour 1/2 ounce of SAE 10 weight oil into the engine through the spark plug hole. Rotate engine crankshaft by hand several times, then install spark plug and tighten to 20 ft-lb (27 N·m).
14. Adjust tires to rated capacities. **See General Information, Section 8, Page 8-1.**
15. Lubricate front suspension and do all other semiannual periodic lubrication. **See Periodic Lubrication Schedule, Section 10, Page 10-3.**
16. Thoroughly clean body, seats, cargo bed, engine compartment and underside of vehicle.
17. Do not engage the park brake. Chock the wheels to prevent the vehicle from rolling.

## TO RETURN VEHICLE TO SERVICE

1. Make sure the key switch is OFF and the Forward/Reverse handle is in the NEUTRAL position. Remove the key. Chock the wheels.
2. Remove plug from vent tube and connect to tank vent (**Figure 3-2, Page 3-3 or Figure 3-3, Page 3-3**).
3. Connect battery and spark plug wire(s). **See Connecting The Battery on page 1-3.**
4. Completely open fuel shut-off valve (**Figure 3-4, Page 3-4 and Figure 3-5, Page 3-4**). A partially closed fuel valve combined with the use of the choke, can result in a fouled spark plug and engine failure.
5. Make sure the Forward/Reverse handle is in the NEUTRAL position.
6. Crank the engine until it starts. Turn the engine off. **See following NOTE.**

**NOTE:** Due to the oil added to the engine in preparation for storage, engine may smoke excessively for a short time when it is run for the first time after storage.

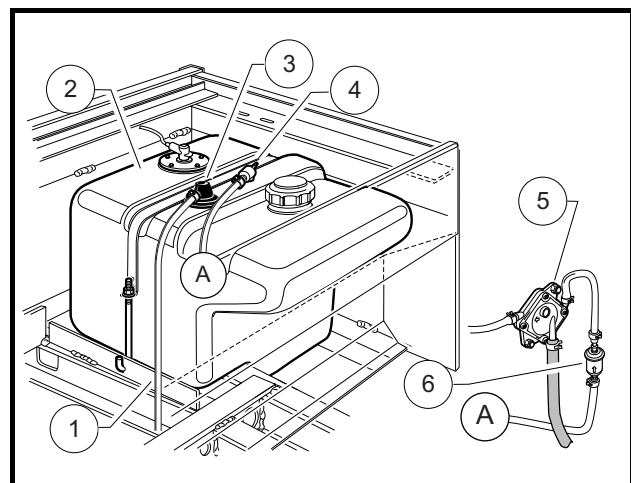
7. Adjust tires to recommended tire pressure. **See General Information, Section 8, Page 8-1.**



**Figure 3-2 Turf-CA 272/XRT 1200 Fuel Tank**

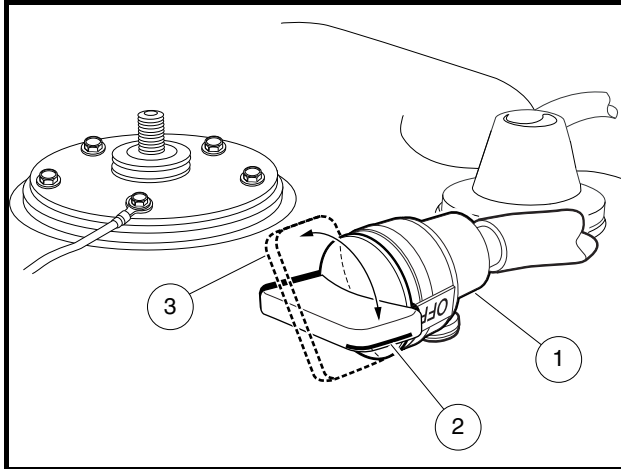
1. Vent Tube\* 2. To Carburetor 3. Vent 4. Fuel Shut-off Valve 5. Fuel Tank

\*Vehicle without carbon canister shown.



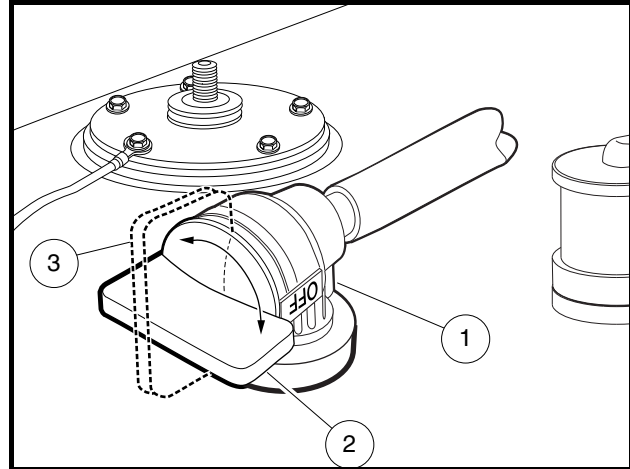
**Figure 3-3 Carryall 472/XRT 1200 SE Fuel Tank**

1. Vent Tube 2. Fuel Tank 3. Vent 4. Fuel Shut-off Valve 5. Fuel Pump (under rear seat) 6. Fuel Filter (under rear seat)



**Figure 3-4 Fuel Shut-off Valve – 49-State Fuel Tank**

1. Fuel Shut-off Valve 2. Closed (OFF) 3. Open (ON) NOTE: When selecting valve position, ensure that it is fully opened or fully closed.



**Figure 3-5 Fuel Shut-off Valve – California Fuel Tank**

1. Fuel Shut-off Valve 2. Closed (OFF) 3. Open (ON) NOTE: When selecting valve position, ensure that it is fully opened or fully closed.



## SECTION 4 – BODY AND TRIM

---

### **⚠ DANGER**

- See General Warning, Section 1, Page 1-1.

### **⚠ WARNING**

- See General Warning, Section 1, Page 1-1.

### **CAUTION**

- Do not use detergents or cleaning solvents that contain ammonia, aromatic solvents, or alkali materials on body panels or seats.
- Do not allow battery acid to drip on body panels. Battery acid will cause permanent damage. Wash spilled battery acid from body panels immediately.

## CLEANING THE VEHICLE

---

### **Read General Warning, Section 1, Page 1-1.**

Each vehicle is equipped with an ABS/DR acrylic front body, an all-aluminum rear body and frame, and either an aluminum or steel cargo bed. Use a commercial automotive cleaning solutions with a sponge or soft cloth for normal cleaning. A garden hose at normal residential water pressure is adequate. To remove oxidation or discoloration from aluminum, use a commercially available aluminum cleaner paste and fine grade (No. 00) steel wool.

Club Car does not recommend any type of pressure washing or steam cleaning. Such a process will expose electrical components to moisture. Moisture entering electrical components can result in water damage and subsequent component failure.

Use non-abrasive wax products. Battery acid, fertilizers, tars, asphalt, creosote, paint, or chewing gum should be removed immediately to prevent possible stains

The front body is made of an ABS/DR acrylic cap material similar to the material used to manufacture hot tubs and shower/tub units. Cleaning and repair techniques for the front body are the same as those used on conventional acrylic sheet. Use cleaning and polishing products available at any hardware store where ABS/DR acrylic (hot tubs and shower/tub units) are sold.

The seats of the vehicle will last longer with proper cleaning. Use a solution of 10% liquid soap and warm water applied with a soft cloth. For imbedded dirt, a soft bristle brush may be used. For heavy soiling, difficult stains, or scratches, blemishes, or other body damage, see the appropriate maintenance and service manual. **See following NOTE.**

**NOTE:** *Dispose of waste water properly.*

## FRONT BODY REPAIR

---

Read General Warning, Section 1, Page 1-1.

### ABRASIONS AND HAZE

The original gloss can be restored by hand buffing with “Novus Plastic Polish”, “Mirror Glaze Professional Formula Number 17”, or similar polishing compounds. A buffing wheel with a small amount of automotive type paste wax applied to the pad may also be used. Use a very light touch, because ABS/DR acrylic polishes easily. Johnson’s® “J-Wax” or “Kit” may be applied as a final treatment.

### LIGHT SCRATCHES

Ajax cleanser applied dry and hand-rubbed will rapidly smooth moderate scratches. Use a soft polishing compound to restore gloss.

Scratches (up to 10 mils; the equivalent thickness of an average business card) can be removed by light sanding. Start with wet silicone carbide abrasive paper (320 grit or finer). Use progressively finer grits (i.e. 400, 600, 800) to reduce sanding marks. Use Ajax cleanser (or equivalent) for final smoothing. A “Micro Mesh” acrylic polishing kit with abrasive papers from 1800 to 8000 grit will provide the best final finish. Restore gloss with soft polishing compound. It is not the intent of any of these processes to fill-in material removed due to light scratches but rather to blend the finish of the surrounding area and the scratch together.

### LARGE SCRATCHES AND ABRASIONS

Touch-up is not recommended. Replace the entire body part or have it repaired by a professional paint and body repair shop with experience repairing ABS/DR acrylic bodies.

## TUBE BUMPER/BRUSH GUARD

---

Read General Warning, Section 1, Page 1-1.

### TUBE BUMPER/BRUSH GUARD REMOVAL

Remove the truss-head screws (14) and nuts (15) that secure the tube bumper or brush guard to the vehicle frame (**Figure 4-2, Page 4-6**).

### TUBE BUMPER/BRUSH GUARD INSTALLATION

Installation is the reverse of removal. Tighten the nuts (15) to 15 ft-lb (20.3 N·m) (**Figure 4-2, Page 4-6**).

## FRONT BODY COMPONENTS

---

Read General Warning, Section 1, Page 1-1.

### DASHBOARD REMOVAL

1. Make sure the key switch is OFF and the Forward/Reverse handle is in the NEUTRAL position. Remove the key. Chock the wheels.
2. Disconnect battery and spark plug wire(s). **See Disconnecting The Battery on page 1-3.**
3. Remove the dash panel:
  - 3.1. Loosen the seven Tuflok<sup>®</sup> screws shown in Detail A (**Figure 4-1, Page 4-4**).
  - 3.2. Remove Tuflok screws from dash panel shown in Detail B.
  - 3.3. Pull forward on top of dash panel to access back of panel.
4. Disconnect the wiring from components mounted in the dash panel.
5. Remove five caps (1) from top of dashboard (2) (**Figure 4-2, Page 4-6**).
6. Remove screws (3) and special plastic washers (4) from top of dashboard (2) using a Torx #T-30 driver.
7. Remove five screws (5) from underside of dashboard and pull dashboard away from front body (6).
8. Remove the steering wheel. **See Steering Wheel Removal, Section 7, Page 7-1.**
9. Remove dashboard from vehicle.

### DASHBOARD INSTALLATION

1. Reverse the dashboard removal process.
2. Tighten screws (5) to 11 in-lb (1.2 N·m) (**Figure 4-2, Page 4-6**).
3. Tighten Torx-head screws (3) with plastic washers (4) to 45 in-lb (5.1 N·m).
4. Install five caps (1).
5. Install dash panel and connect wiring to panel components.
6. Install steering wheel. **See Steering Wheel Installation, Section 7, Page 7-3.**

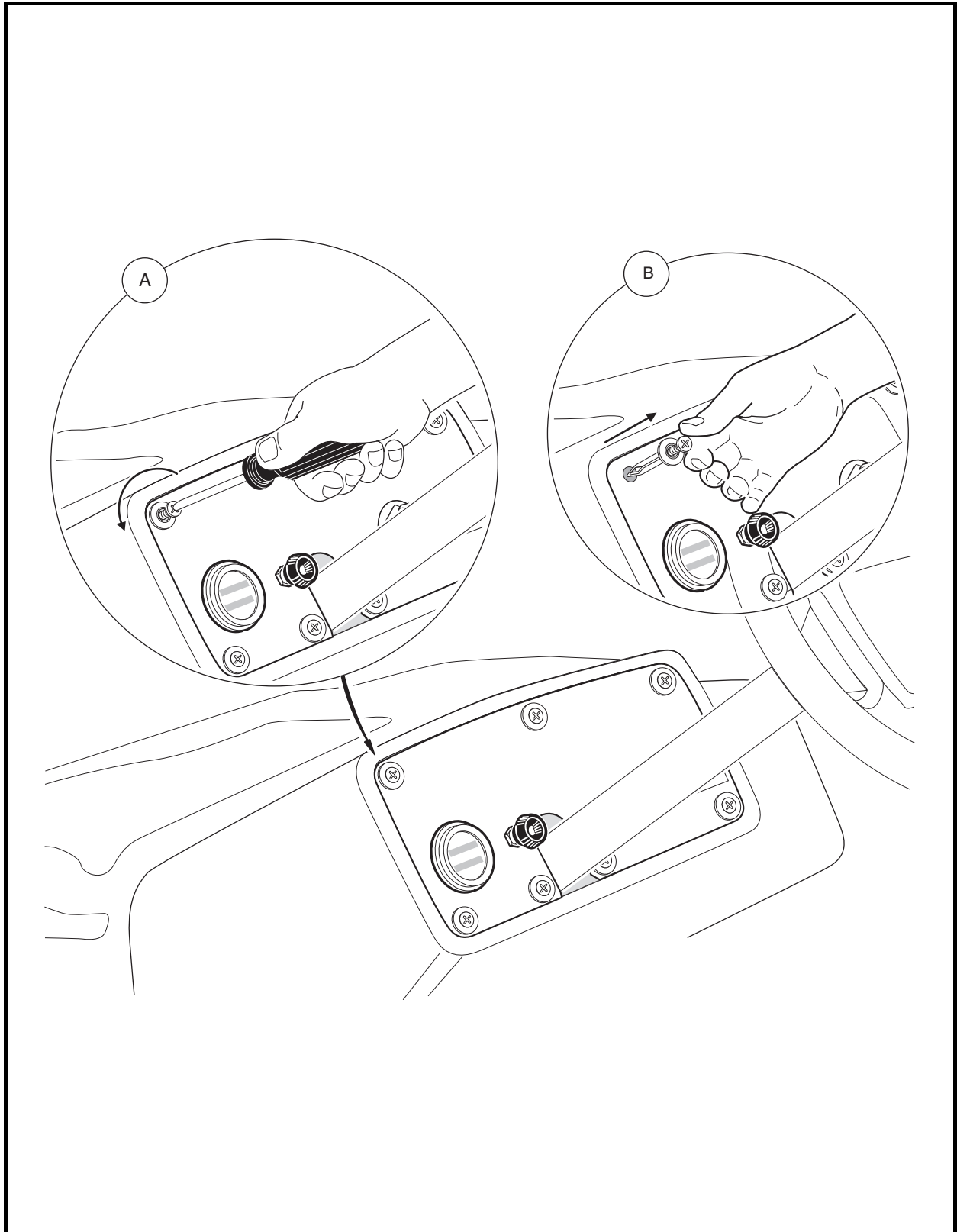


Figure 4-1 Dash Panel Removal

## FRONT BODY REMOVAL

1. Remove five caps (1) from top of dashboard (2) (**Figure 4-2, Page 4-6**).
2. Use a Torx #T-30 driver to remove the Torx-head screws (3) and washers (4) from top of front body (6).
3. Use a 5/16 nut driver to remove five screws (5) from underside of dashboard (2) and gently slide dashboard away from front body (6).
4. Use a phillips head screwdriver to remove the six Tuflok fasteners (7) from sides and two (7) from front of front body (6).
5. Disconnect lighting wiring harness from each headlight assembly.
6. Lift the back edge of the body up and pull forward to remove from vehicle (**Figure 4-2, Page 4-6**).

## FRONT FENDER REMOVAL

1. Remove front body (6) (**Figure 4-2, Page 4-6**). See **Front Body Removal on page 4-5**.
2. Pull back floor mat to access rivets securing front fender (9) to frame. Drill out two 3/16 x 5/8 pop rivets (10) and remove two washers (11).
3. Use a 3/8 hex-head socket to remove two screws (12) from fender frame support and remove fender.

## FRONT FENDER INSTALLATION

1. Reverse the fender removal process (**Figure 4-2, Page 4-6**).
2. Tighten screws (12) to 50 in-lb (5.7 N·m).
3. Pop rivet fender to frame using two 3/16 x 5/8 pop rivets (10) and two 3/16 rivet washers (11).
4. Install front body. See **Front Body Installation on page 4-5**.

## FRONT BODY INSTALLATION

1. Reverse the front body (6) removal process (**Figure 4-2, Page 4-6**).
2. Secure front body (6) to dashboard (2) with screws (3) and plastic washers (4) and tighten to 45 in-lb (5.1 N·m).
3. Install five caps (1).
4. Secure front body (6) to fenders (9) with fasteners (7) and push the heads in until they snap into place.

## SEAT

---

### Read General Warning, Section 1, Page 1-1.

Clean seats regularly using the following guidelines: **See following CAUTION.**

### **CAUTION**

- **To prevent damage to the vehicle when removing difficult stains or heavy soiling, remove the seat from the vehicle first.**

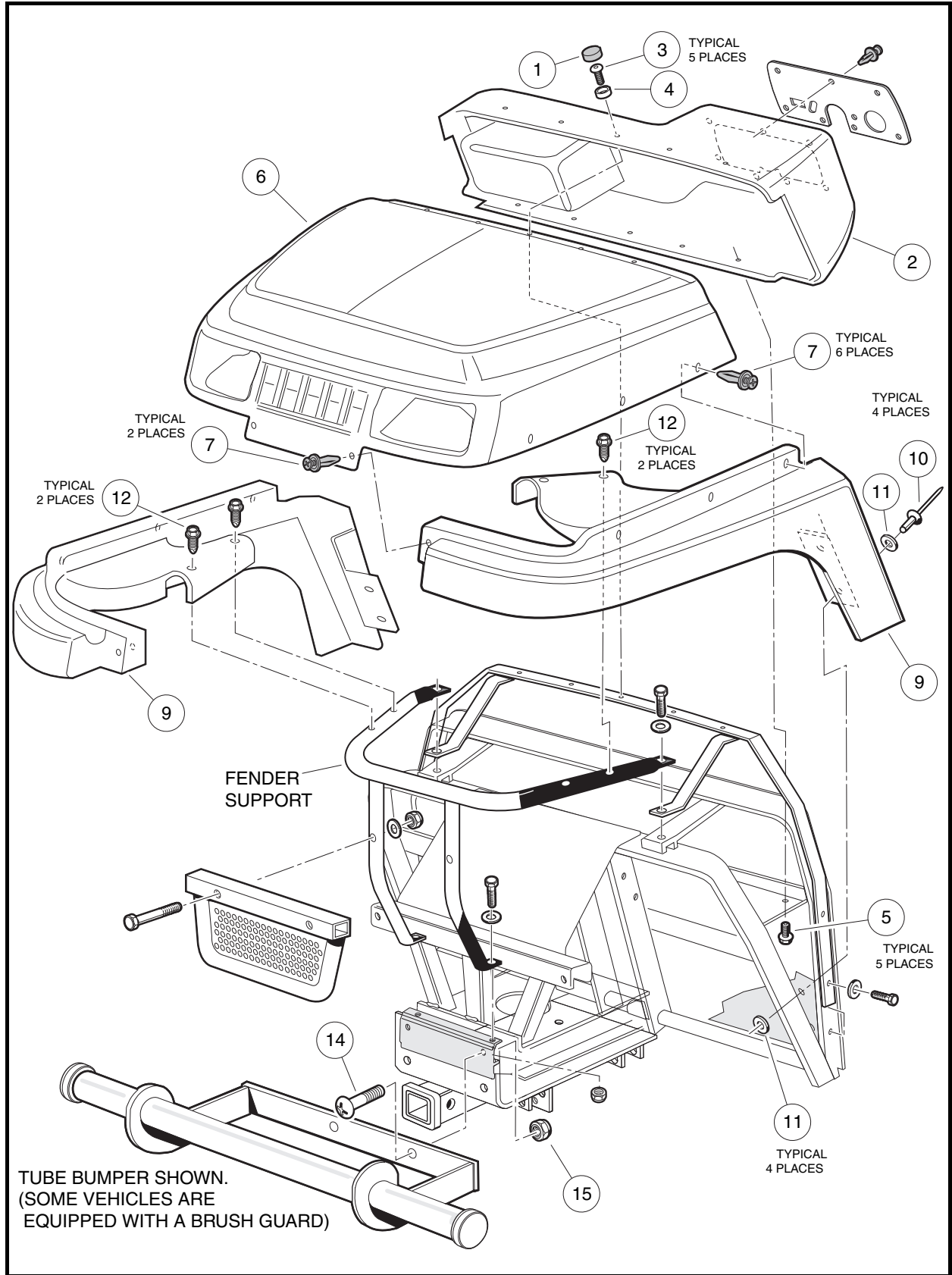


Figure 4-2 Front Body Assembly

**Light Soiling** – A solution of 10% liquid dish soap and warm water applied with a soft, damp cloth is recommended. A soft bristle brush may be used if necessary. Wipe off any residue with a water dampened cloth.

**Difficult Stains** – Dampen a soft, white cloth with a solution of 10% household bleach (sodium hypochlorite) and 90% water. Rub gently to remove stain, then rinse with a water dampened cloth to remove bleach concentration.

**For More Difficult Stains** – Perform previous procedure using full-strength bleach, or allow bleach to puddle on affected area for approximately 30 minutes. Rinse with a water dampened cloth to remove any remaining bleach concentration.

## SEAT ADJUSTMENT

1. Remove seat (2) from vehicle.
2. Disassemble seat (2) from seat panel (3) by removing four bolts (4) and lockwashers (5) (**Figure 4-3, Page 4-8**).
3. Adjust seat to preferred position. Align holes in seat panel (3) with holes in seat (2) and secure with four bolts (4) and lockwashers (5). Tighten bolts to 96 in-lb (10.8 N·m). **See following WARNING.**

### **⚠ WARNING**

- **Make sure seat hinges and latch are securely engaged before operating vehicle.**

## FRONT SEAT SUPPORT

**Read General Warning, Section 1, Page 1-1.**

### FRONT SEAT SUPPORT REMOVAL

1. Completely remove both front seats (2) from the vehicle (**Figure 4-3, Page 4-8**).
2. Remove park brake equalizer cable from park brake handle. **See Equalizer Cable Removal, Section 6, Page 6-33.**
3. Disconnect cable from differential lock control. **See step 5 in Unitized Transaxle Removal, Section 16, Page 16-7.**
4. Remove four hex-head bolts (8), eight washers (9) and four locknuts (10) from the seat support (**Figure 4-3, Page 4-8**).
5. Remove the two armrests (11 and 12) from the seat support (1).
6. Lift seat support (1) from vehicle.

### FRONT SEAT SUPPORT INSTALLATION

1. Reverse the front seat support removal process (**Figure 4-3, Page 4-8**).
2. Assemble bolts (8), washers (9), and locknuts (10) to seat support and armrests (11 and 12) and tighten bolts (8) to 13 ft-lb (17.6 N·m). **See following WARNING.**

### **⚠ WARNING**

- Both armrests must be installed before operating the vehicle, unless the vehicle is fitted with a structural cab.
3. Connect differential lock cable to differential lock handle. **See step 33 of Unitized Transaxle Installation, Section 16, Page 16-21.**
  4. Install park brake equalizer cable. **See Equalizer Cable Installation, Section 6, Page 6-34.**
  5. Install both front seats (2) onto the vehicle.

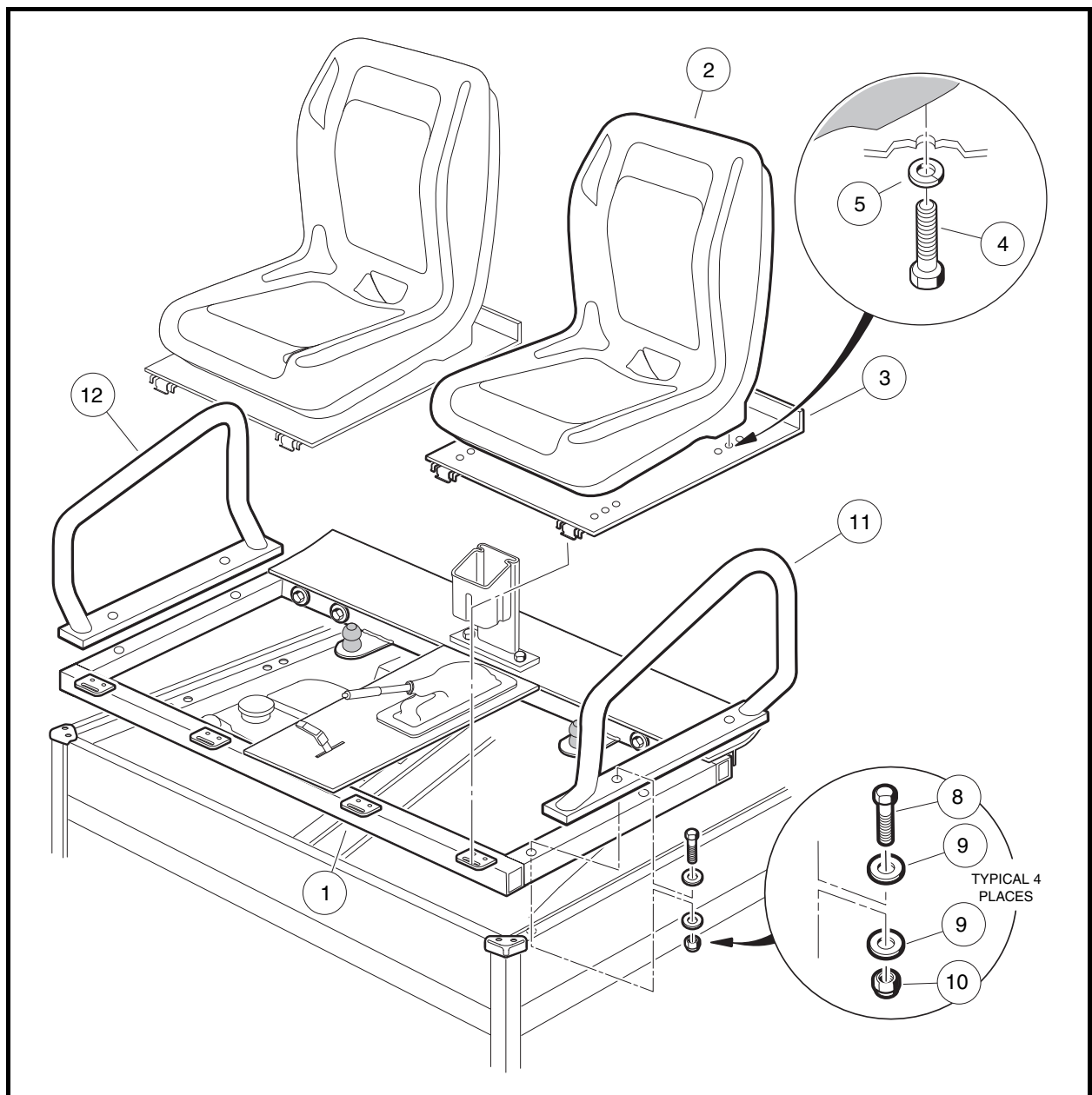


Figure 4-3 Front Seat Support



## REAR SEAT SUPPORT

---

Read General Warning, Section 1, Page 1-1.

### REAR SEAT SUPPORT REMOVAL (CARRYALL 472/XRT 1200 SE)

1. Lift rear seat cushion and remove from the vehicle.
2. Remove eight 1/4-20 flange nuts (21) and eight 1/4-20 x 3/4-inch carriage bolts (20) and remove arm rests (10 and 11) (**Figure 4-4, Page 4-10**).
3. Remove four 1/4-20 x 1 inch, phillips drive, truss-head machine screws (19) and lockwashers (18) from seat back support (22) and remove seat back (16) and seat back cap (17).
4. Remove four 5/16-18 flange locknuts (24) and four 5/16-18 x 3/4-inch carriage bolts (23) and remove seat back support (22).
5. Remove seat bottom rear trim (13) by pushing-out, from the back of the seat back support (22), five plastic barrel connectors (12).
6. Remove the seat bottom front trim (14) by lifting the lower inside flange slightly across the entire seat area. Push the trim toward the rear of the vehicle, allowing the top flange to slide away from the seat frame toward the rear of the vehicle.

### REAR SEAT SUPPORT INSTALLATION (CARRYALL 472/XRT 1200 SE)

1. Slide the seat bottom front trim toward the front edge of the seat frame with the top flange of the trim sliding over the top of the frame. Push toward the front of the vehicle until the lower flange snaps into place. The top and bottom flanges of the trim should be in direct contact with the frame structure.
2. Install the seat back support (22) in reverse order of removal. Tighten hardware to 15 ft-lb (20.34 N·m).
3. Install a new seat bottom rear trim using new barrel connectors.
4. Install arm rests (10 and 11) in reverse order of removal. Tighten hardware to 65 in-lb (7.345 N·m).
5. Install seat back (16) and seat back cap (17) in reverse order of removal. Tighten hardware to 6 ft-lb (8.136 N·m).
6. Install bottom bench seat, aligning the front edge of the seat against the inside edge of the front trim, and push down into place.

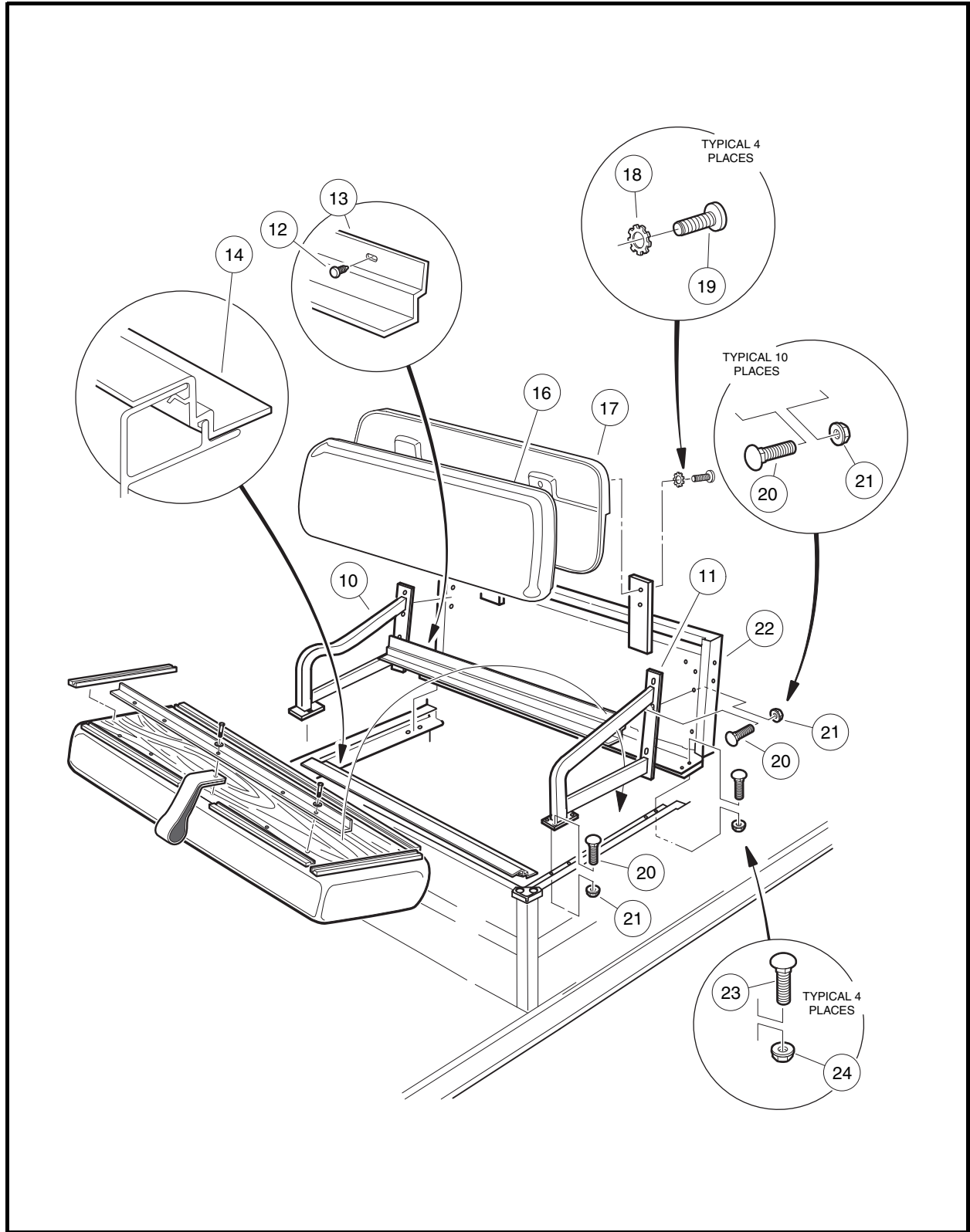


Figure 4-4 Carryall 472/XRT 1200 SE Rear Seat Support

## CARGO BED

---

Read General Warning, Section 1, Page 1-1.

### CARGO BED REMOVAL

**NOTE:** Cargo bed removal and installation will be easier with the help of an additional person.

#### 1. Turf 272/Carryall 272/XRT 1200:

- 1.1. Raise bed and ensure that the prop rod (25) is secured in the prop rod track (2). Hold bed securely in an upright position. Remove cotter pin (3) and flat washer (4) from top end of prop rod where prop rod attaches to bed. Remove prop rod (25) from bed and place prop rod between prop rod track (2) and rear body panel. Lower bed onto vehicle frame (**Figure 4-5, Page 4-12**).
- 1.2. Remove two 3/8-16 nylon locknuts (8) from left and right cargo bed hinge/bolt assemblies.
- 1.3. Apply slight upward pressure (by hand) on the rear of the bed to relieve pressure on the hinges, and remove the 3/8 x 3-3/8-inch hinge bolts (9) from the hinge assemblies.
- 1.4. Raise rear edge of bed approximately 6 inches (15.2 cm) and pull bed assembly toward rear of vehicle (approximately 3 inches (7.6 cm) to release bed latch assembly (10) from latch plate (11) and lift bed from vehicle.

#### 2. Carryall 472/XRT 1200 SE:

- 2.1. Remove two 3/8-16 nylon locknuts (2) from left and right cargo bed hinge/bolt assemblies (**Figure 4-6, Page 4-13**).
- 2.2. Apply slight upward pressure (by hand) on the rear of the bed to relieve pressure on the hinges, and remove the 3/8 x 3-3/8-inch hinge bolts (1) from the hinge assemblies.
- 2.3. Raise rear edge of bed approximately 6 inches (15.2 cm) and pull bed assembly toward rear of vehicle (approximately 3 inches (7.6 cm)) to release bed latch assembly (6) from latch plate (11) and lift bed from vehicle.

### CARGO BED INSTALLATION

**NOTE:** Cargo bed removal and installation will be easier with the help of an additional person.

#### 1. Turf 272/Carryall 272/XRT 1200:

- 1.1. Hold front of bed lower than rear of bed and place front edge of bed onto vehicle frame and align latches (10) with latch plates (11) (**Figure 4-5, Page 4-12**).

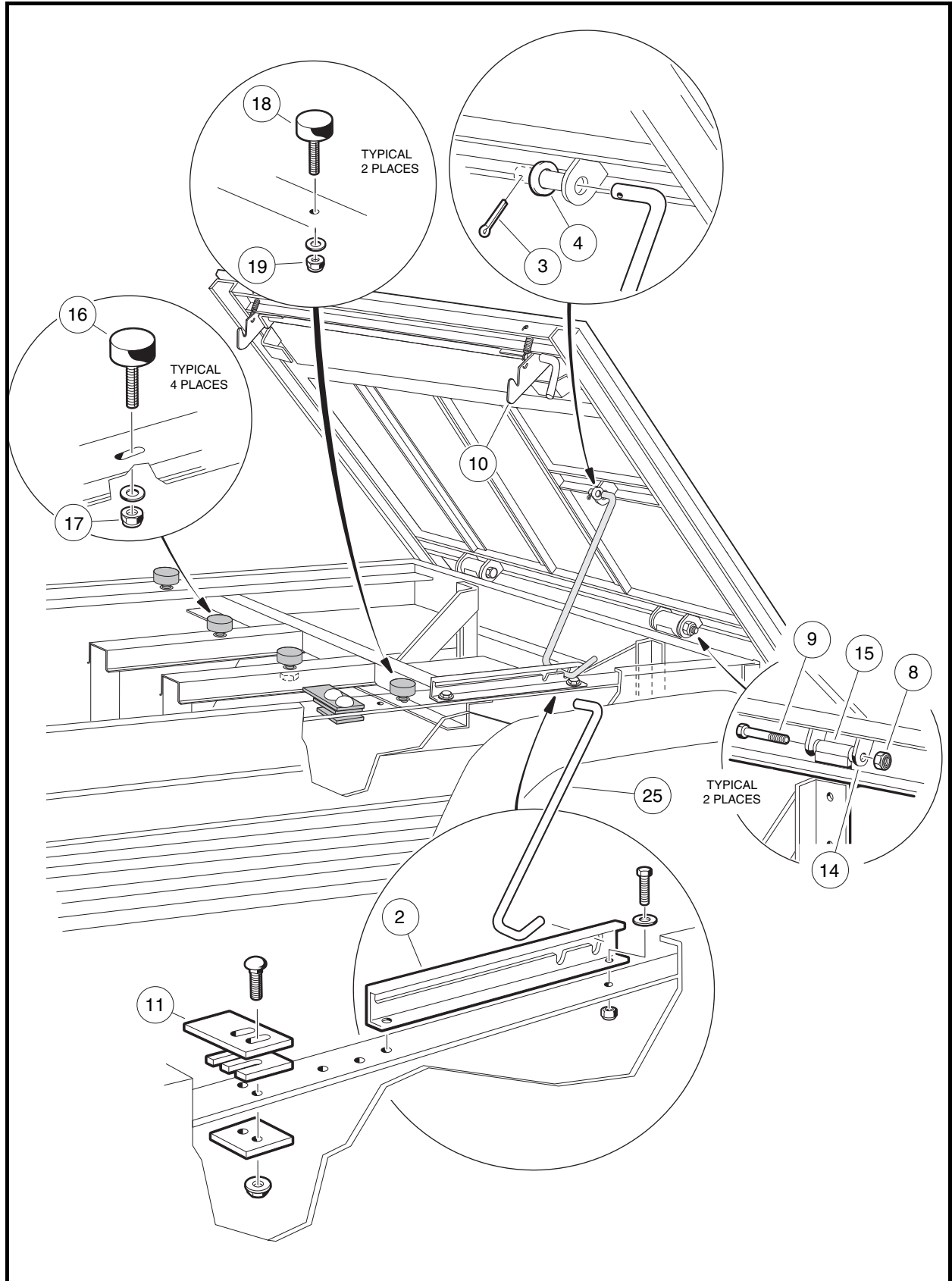
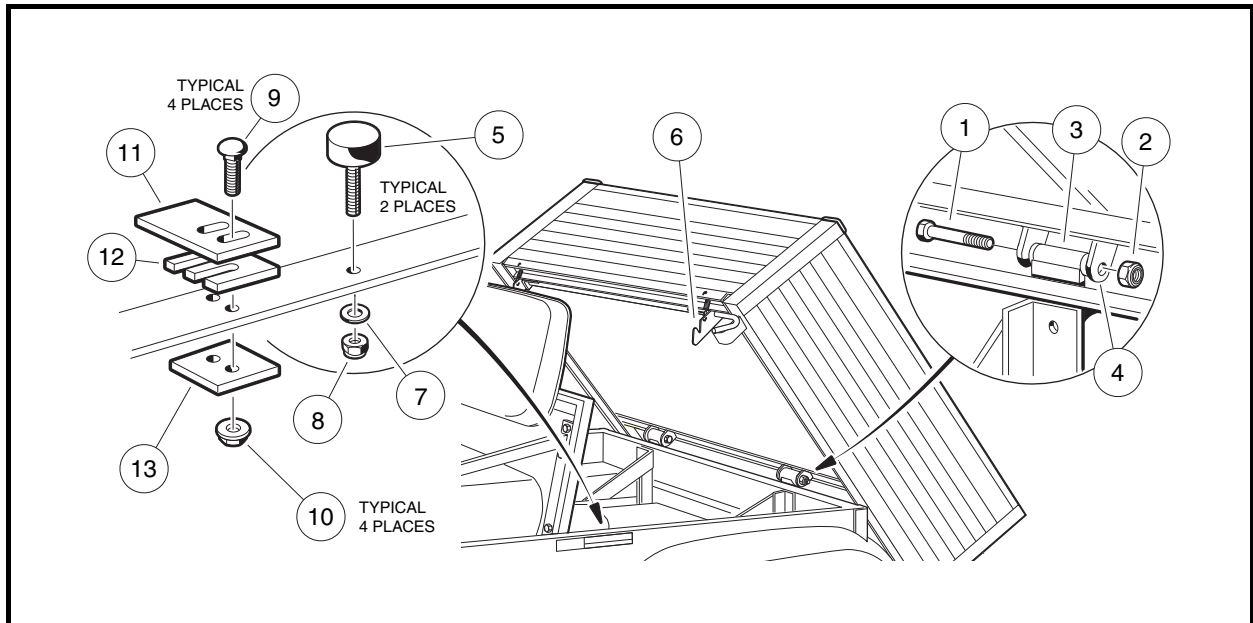


Figure 4-5 Turf/CA 272/XRT 1200 Cargo Bed



**Figure 4-6 Carryall 472/XRT 1200 SE Cargo Bed**

- 1.2. Lower rear edge of bed onto vehicle and align frame hinge brackets (14) with bed hinge brackets (15).
- 1.3. Start the bolts (9) into left and right hinge assemblies. Use alignment tool if necessary.
- 1.4. Use a small hammer to lightly tap bolts through hinge assembly.
- 1.5. Install nylon locknut (8) on each bolt (9) and tighten to 15 ft-lb (21 N·m).
- 1.6. Lift bed from bed latch and with prop rod in a slot notch, place prop rod (25) in bed mounting hole and install flat washer (4) and a new cotter pin (3) onto prop rod.
- 1.7. Proceed to Bed Stop Bumper Adjustment on page 4-13.

## 2. Carryall 472/XRT 1200 SE:

- 2.1. Hold front of bed lower than rear of bed and place front edge of bed onto vehicle frame and align bed latches (6) with latch plates (11) (**Figure 4-6, Page 4-13**).
- 2.2. Lower rear edge of bed onto vehicle and align frame hinge brackets (3) with bed hinge brackets (4).
- 2.3. Start the bolts (1) into left and right hinge assemblies. Use an alignment tool if necessary.
- 2.4. Use a small hammer to lightly tap bolts through hinge assembly.
- 2.5. Install nylon locknuts (2) on each bolt (1) and tighten to 15 ft-lb (20 N·m).
- 2.6. Proceed to Bed Stop Bumper Adjustment on page 4-13.

## BED STOP BUMPER ADJUSTMENT

### 1. Turf 272/Carryall 272/XRT 1200:

- 1.1. Adjust the two front bumpers (16) by loosening the 1/4-20 nylon locknuts (17) and position so that when the cargo bed is lowered, both bumpers are centered on the bed frame weldments (**Figure 4-5, Page 4-12**).
- 1.2. Tighten locknuts (17) to 20 in-lb (2.3 N·m).
- 1.3. Adjust the two rear bumpers (18) loosening the 1/4-20 nylon locknuts (19) until a 1/8-inch gap between the bottom of the bumper head and the frame weldment is achieved. Do not tighten to the frame. The bumper is designed to "float." Weldments on the frame should rest on these two bumpers.

## 2. Carryall 472/XRT 1200 SE:

- 2.1. Adjust the two bed stop bumpers (5) by loosening the 1/4-20 nylon locknuts (7) and washers (6) and position so that when the cargo bed is lowered, both bumpers are centered on the bed frame weldments (**Figure 4-6, Page 4-13**).
- 2.2. Tighten locknuts (8) to 20 in-lb (2.3 N·m).

## REAR FENDER

---

Read General Warning, Section 1, Page 1-1.

### REAR FENDER REMOVAL

1. Remove one 1/4-20 nylon locknut (5), fender washers (4) and 1/4-20 x 1-inch hex-head bolt (3) from the top, and underneath, of fender (1) (**Figure 4-7, Page 4-16 or Figure 4-8, Page 4-17**).
2. Remove the two 1/4-20 nylon locknuts (5), fender washers (4) and 1/4-20 x 1-inch hex-head bolts (3) from the front surface of the fender (1).
3. Remove the two 1/4-20 nylon locknuts (5), fender washers (4) and 1/4-20 x 1-inch hex-head bolts (3) attaching the fender wall (1) to the vehicle frame.
4. Remove fender (1) from the vehicle.
5. Repeat steps 1 through 4 for removal of the opposite fender if necessary.

### REAR FENDER INSTALLATION

1. Reverse the rear fender removal process. Tighten bolts to 35 in-lb (4.0 N·m) (**Figure 4-7, Page 4-16 or Figure 4-8, Page 4-17**). See following NOTE.

**NOTE:** Use new nylon locknuts when performing this assembly procedure.

*The rear fender with the warning decal should be installed on the passenger side of the vehicle.  
The decal should be plainly visible when the cargo bed is raised.*

## TAILSKIRT

---

Read General Warning, Section 1, Page 1-1.

### TAILSKIRT REMOVAL

1. Remove the two thread-forming screws (7) and flat washers (8) from the tailskirt (6) and slide tailskirt from under the back edge of the rear of the body and vehicle frame (**Figure 4-7, Page 4-16 or Figure 4-8, Page 4-17**).

### TAILSKIRT INSTALLATION

1. Installation is the reverse of removal. Tighten screws (7) to 55 in-lb (6.2 N·m) (**Figure 4-7, Page 4-16 or Figure 4-8, Page 4-17**).

## TRAILER HITCH

---

Read General Warning, Section 1, Page 1-1.

### TRAILER HITCH REMOVAL

**1. Turf 272/Carryall 272/XRT 1200:**

- 1.1. Remove the tailskirt. **See Tailskirt Removal on page 4-14.**
- 1.2. Remove two 5/16-18 hex nuts (20), lockwashers (21), flat washers (22) and 5/16-18 x 1-inch bolts (23) from hitch brace (10) and hitch frame (8) (**Figure 4-7, Page 4-16**).
- 1.3. Remove two 5/16-18 hex nuts (13), lockwashers (12) flat washers (11) and 5/16-18 x 1-inch bolts (18) where the hitch frame (8) mounts to the vehicle frame and remove the hitch.

### TRAILER HITCH INSTALLATION

**1. Turf 272/Carryall 272/XRT 1200:**

- 1.1. Reverse the trailer hitch removal process and tighten bolts to 15 ft-lb (20.3 N·m) (**Figure 4-7, Page 4-16**).
- 1.2. Install the tailskirt. **See Tailskirt Installation on page 4-14.**

## RECEIVER HITCH

---

### RECEIVER HITCH REMOVAL

**1. Carryall 472/XRT 1200 SE:**

- 1.1. Remove the tailskirt. **See Tailskirt Removal on page 4-14.**
- 1.2. Remove two 5/16-18 hex nuts (13), lockwashers (12), flat washers (14) and 5/16-18 x 1-inch bolts (15) from the top of hitch (10) brace (**Figure 4-8, Page 4-17**).
- 1.3. Remove two 5/16-18 hex nuts (13), lockwashers (12), flat washers (14) and 5/16-18 x 1-inch bolts (15) where the hitch frame (10) mounts to the vehicle frame and remove the hitch.

### RECEIVER HITCH INSTALLATION

**1. Carryall 472/XRT 1200 SE:**

- 1.1. Reverse the receiver hitch removal process and tighten bolts to 15 ft-lb (20.3 N·m) (**Figure 4-8, Page 4-17**).
- 1.2. Install the tailskirt. **See Tailskirt Installation on page 4-14.**

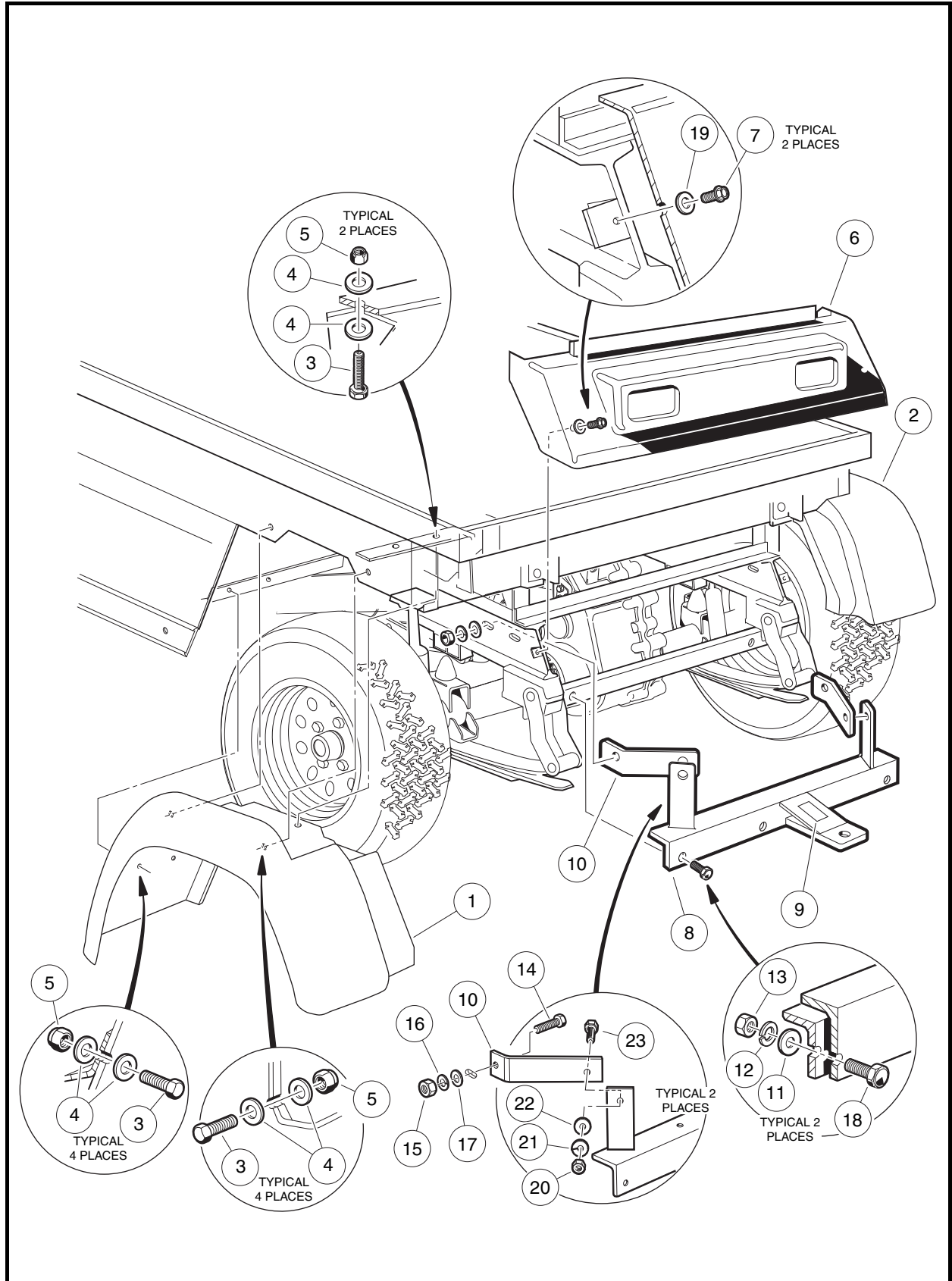


Figure 4-7 Turf 272/Carryall 272/XRT 1200 Rear Fender, Tailskirt, and Trailer Hitch



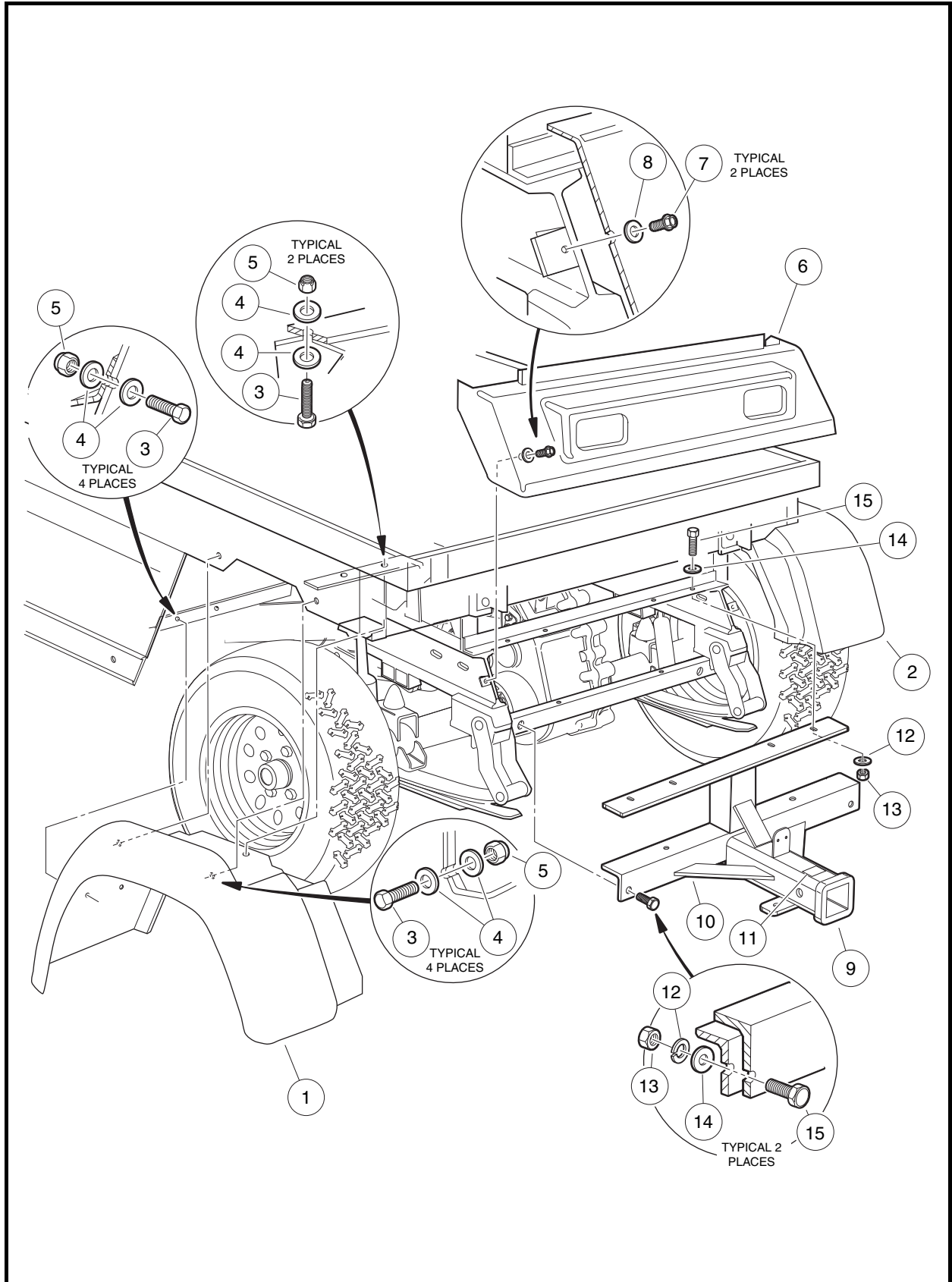


Figure 4-8 Carryall 472/XRT 1200 SE Rear Fender, Tailskirt, and Receiver Hitch

## FLOOR MAT

---

Read General Warning, Section 1, Page 1-1.

### FLOOR MAT REMOVAL

**1. Turf 272/Carryall 272/XRT 1200:**

- 1.1. Remove the brake and accelerator pedals. **See Accelerator Pedal Removal, Section 5, Page 5-5. Also see Brake Pedal Removal, Section 5, Page 5-1.**
- 1.2. Remove the top edge of the floor mat from the overlapping flange under the dash, and remove the mat.

**1. Carryall 472/XRT 1200 SE:**

- 1.1. Begin at the corner where the rear seat frame meets the floorboard and roll the mat corner toward the center of the vehicle, from under the side support angle, pulling it diagonally from the vehicle.

### FLOOR MAT INSTALLATION

**1. Turf 272/Carryall 272/XRT 1200:**

- 1.1. Install the floor mat in the reverse order of removal.
- 1.2. Install the brake and accelerator pedals. **See Brake Pedal Installation, Section 5, Page 5-1. Also see Accelerator Pedal Installation, Section 5, Page 5-5.**

**2. Carryall 472/XRT 1200 SE:**

- 2.1. Begin at the corners of where the rear seat frame meets the floorboard, and slide each corner under the frame, sliding each side under the angle supports and lastly lapping the edge against the back of the front seat support.

# SECTION 5 – ACCELERATOR AND BRAKE PEDAL ASSEMBLIES

---

## **⚠ DANGER**

- See General Warning, Section 1, Page 1-1.

## **⚠ WARNING**

- See General Warning, Section 1, Page 1-1.

## **BRAKE PEDAL**

---

See General Warning, Section 1, Page 1-1.

### **BRAKE PEDAL REMOVAL**

1. Make sure key switch is OFF and the Forward/Reverse handle is in the NEUTRAL position. Remove the key.
2. Disconnect battery and spark plug wire(s). **See Disconnecting The Battery on page 1-3.**
3. Place chocks under rear wheels and lift front end of vehicle with a chain hoist or floor jack. Place jack stands under the outer front I-beam of the vehicle frame and lower the vehicle onto the jack stands (**Figure 5-2, Page 5-3**). **See following WARNING.**

## **⚠ WARNING**

- **Lift only one end of the vehicle at a time. Use a suitable lifting device (chain hoist or hydraulic floor jack) with 1000 lb. (454 kg) minimum lifting capacity. Do not use lifting device to hold vehicle in raised position. Use approved jack stands of proper weight capacity to support the vehicle and chock the wheels that remain on the floor. When not performing a test or service procedure that requires movement of the wheels, lock the brakes.**
4. Remove the brake pedal assembly.
    - 4.1. Remove the bolt (9) and nut (19) (**Figure 5-1, Page 5-2**).
    - 4.2. Remove nuts (4), flat washers (6), bolts (7), and mounting blocks (5). If the mounting blocks (5) show signs of excessive wear, or are damaged, replace with new ones.
    - 4.3. Remove the nut (3) and brake stop bumper (2).
    - 4.4. Lift pedal assembly through the floorboard (**Figure 5-3, Page 5-3**).

### **BRAKE PEDAL INSTALLATION**

1. Insert the brake pedal assembly through the top side of the floorboard (**Figure 5-3, Page 5-3**) and install the brake pedal stop bumper (2) and nut (3) (**Figure 5-1, Page 5-2**) but do not tighten.
2. Position and attach brake pedal assembly and mounting blocks (5) with bolts (7), washers (6), and lock-nuts (4). Tighten to 70 in-lb (7.91 N·m) (**Figure 5-1, Page 5-2**).
3. Attach the equalizer rod (10) to the brake pedal assembly (1). Tighten to 17 in-lb (1.9 N·m).
4. Adjust the brake pedal. **See Brake Pedal Adjustment on page 5-3.**
5. Connect battery and spark plug wire(s). **See Connecting The Battery on page 1-3.**

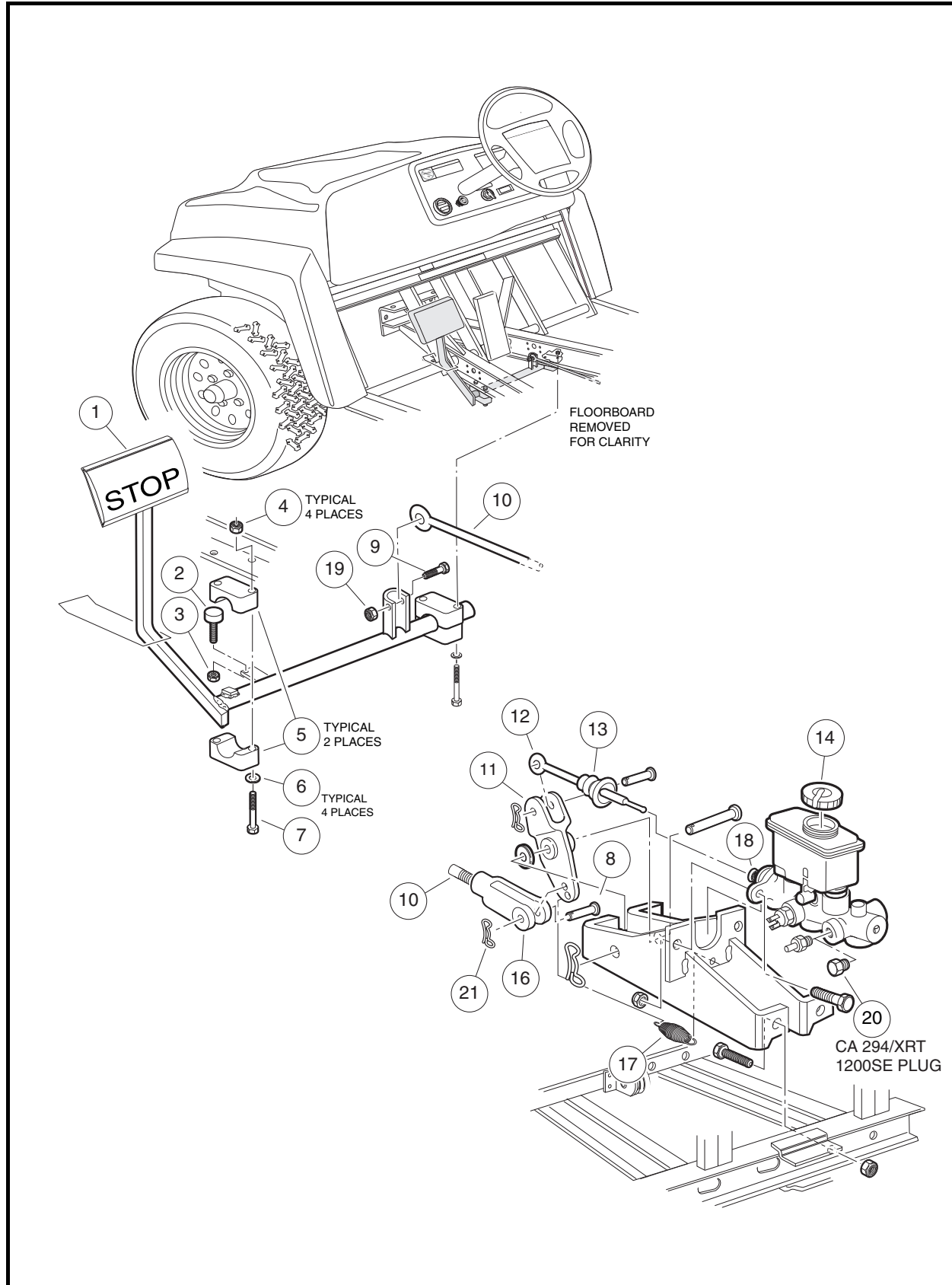


Figure 5-1 Brake Pedal Assembly

## BRAKE PEDAL ADJUSTMENT

See General Warning, Section 1, Page 1-1.

1. Make sure the key switch is OFF and the Forward/Reverse handle is in the NEUTRAL position. Remove the key. Chock the wheels.
2. Remove the brake rod clevis pin (8) and bow tie locking pin (21) from the brake push rod (16) and bell crank (11) (**Figure 5-1, Page 5-2**).

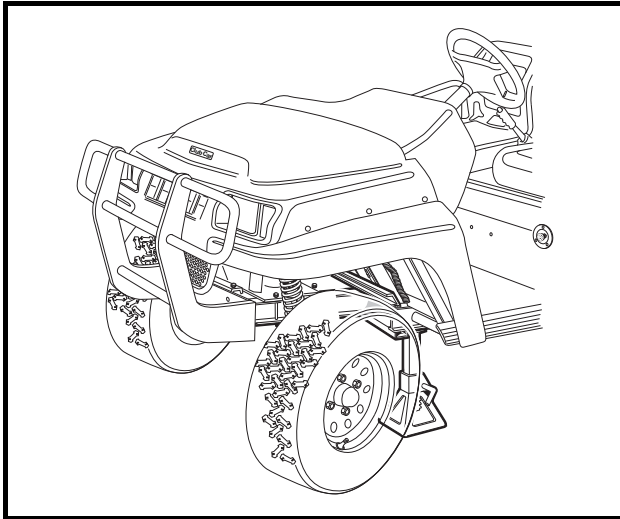


Figure 5-2 Jack Stand Location on I-Beam

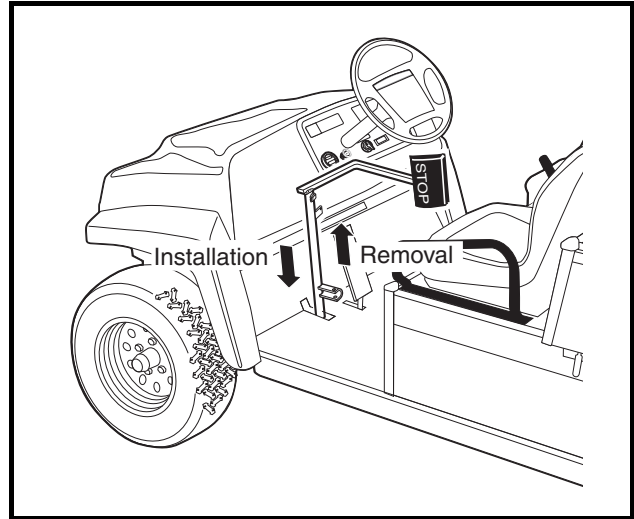


Figure 5-3 Brake Pedal Weldment Through Floor

3. Loosen, but do not remove, the brake stop jam nut (31) (**Figure 5-4, Page 5-3**).
4. Pull the brake pedal toward the rear of the vehicle until the brake stop bumper will not allow the pedal to travel any further (**Figure 5-5, Page 5-3**).
5. Holding the brake pedal in this position, measure the distance from the back of the brake pedal to the floorboard. If it is between 6-3/8 inches (16.2 cm) and 6-7/8 inches (17.5 cm), proceed to step 7.

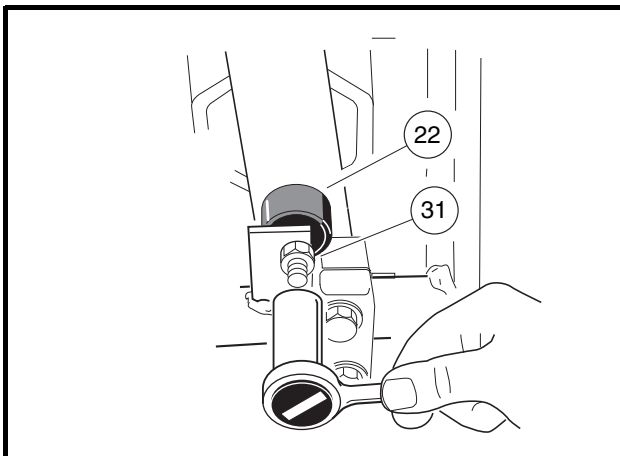


Figure 5-4 Adjust Brake Pedal Height

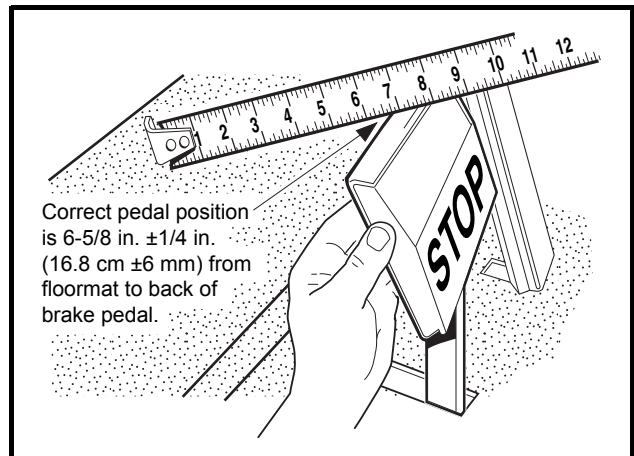


Figure 5-5 Measure Brake Pedal Height

**Brake Pedal Adjustment, Continued:**

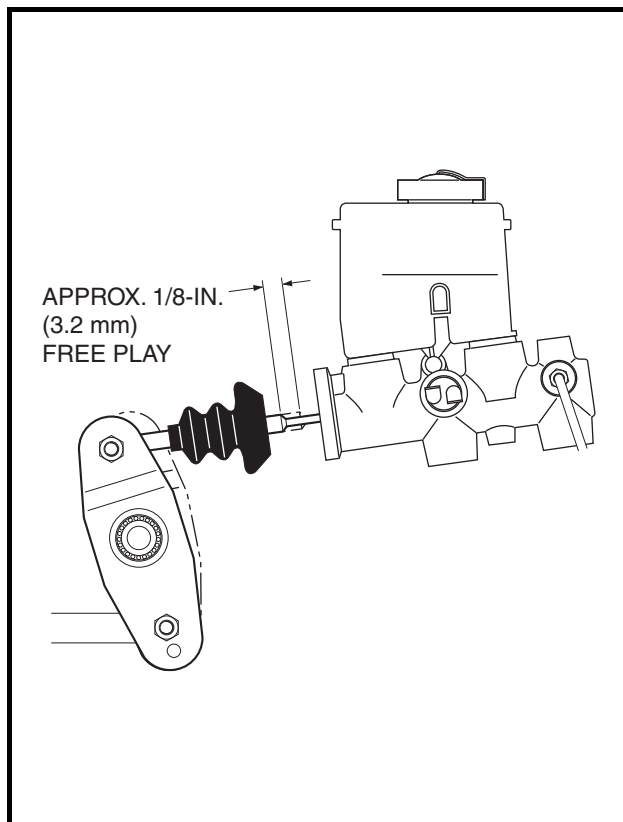
- Adjust the brake stop bumper (22) up to increase the distance between the pedal and the floorboard, or down to increase (Figure 5-4, Page 5-3). Proper brake pedal height is 6-5/8 inches  $\pm$  1/4 inch (16.8 cm  $\pm$  6 mm) (Figure 5-5, Page 5-3).
- Tighten the jam nut (31) to 8 ft-lb (9.5 N-m) (Figure 5-4, Page 5-3).
- Adjust the clevis (16) by rotating it so that the clevis pin (8) can be placed through the clevis (16) and the bottom hole in the bell crank assembly (11) (Figure 5-1, Page 5-2). See following NOTE.

**NOTE:** The spring (17) should not be under tension while the brake pedal is at rest.

- Install the bow tie locking pin (21).
- There should be at least 1/8 inch (3.2 mm) of free play (at the push rod) before the push rod begins to press the master cylinder piston (Figure 5-6, Page 5-4). See following NOTE.

**NOTE:** Brake pedal free play is the distance the push rod (12) travels before the master cylinder piston (18) is pressed (Figure 5-1, Page 5-2). Also see Figure 5-6, Page 5-4.

- Perform all brake system inspections to ensure that the hydraulic brake system and the park brake system are adjusted and operating correctly before placing the vehicle into service. See **Brake System Inspection, Section 6, Page 6-1**.



**Figure 5-6 Push Rod Free Play**

## ACCELERATOR PEDAL

---

See General Warning, Section 1, Page 1-1.

### ACCELERATOR PEDAL REMOVAL

1. Make sure the key switch is OFF and the Forward/Reverse handle is in the NEUTRAL position. Remove the key. Chock the wheels. **See following WARNING.**

#### **⚠ WARNING**

- **Disconnect both battery cables, negative (–) cable first.**
2. Disconnect battery and spark plug wire(s). **See Disconnecting The Battery on page 1-3.**
  3. Place chocks under the rear wheels and lift the front end of the vehicle with a chain hoist or floor jack. Place jack stands under the outer front I-beam of the vehicle frame and lower the vehicle onto the jack stands (**Figure 5-2, Page 5-3**).
  4. Use a 9/16-inch socket and 9/16-inch wrench and remove the nut (23), two washers (25), and bolt (4) securing the accelerator pedal (1) to the pivot rod (6) (**Figure 5-11, Page 5-9**).
  5. Disconnect the accelerator rod assembly (17, 18 and 19) at the front and rear ball studs and remove it from the vehicle.
  6. Remove the nut (10) and ball stud (16) from the accelerator pivot rod (6) and spring retainer (11) assembly.
  7. Slide the spring retainer (11) off of the accelerator pivot rod.
  8. Inspect the pivot support bearing (9), inside the spring retainer, for wear and replace if necessary.
  9. Remove locknut (26) from the accelerator pivot shaft.
  10. Move the brake pedal slightly and then slide the spacer (24) toward end of accelerator pivot rod, releasing the splined fit between the two. Rotate the spacer (24) and remove from the pivot rod (6).
  11. Loosen, but do not remove, the four bolts (22) and locknuts (15).
  12. Slide the pivot rod (6) from the accelerator pivot rod supports (21), nylon spacer (20), and accelerator (1). Remove both the pivot rod (6) and the accelerator pedal (1).

**NOTE:** *The accelerator will release to the top side of the floorboard.*

13. Inspect the accelerator pivot rod support bearings (21) and all parts for wear or damage and replace as necessary (**Figure 5-11, Page 5-9**).

### ACCELERATOR PEDAL INSTALLATION

**NOTE:** *The following procedure will be easier with the help of an additional person.*

1. If replaced, position the supports (21) on the vehicle frame and loosely install the four bolts (22), washers (8), and locknuts (15) and finger-tighten (**Figure 5-11, Page 5-9**).
2. With another person, position accelerator pedal (1) through the floorboard and slide the accelerator pivot rod (6) through the upper hole in the pedal, through the nylon spacer (20), and through the two pivot rod supports (21).

**Accelerator Pedal Installation, Continued:**

3. Tighten bolts (22) to 75 in-lb (8.5 N·m).
4. Install spacer (24), aligning the splined parts, and tighten the nylon locknut (26) to 18 ft-lb (24.5 N·m).
5. Insert bolt (4) through a washer (25) and through the lower hole in the pedal, then through the adjacent slotted hole in the pivot rod (6). Attach the remaining washer (25) and nut (23). Finger-tighten nut. **See Accelerator Pedal Adjustment on page 5-6.**
6. Insert pivot support bearing (9) into spring retainer (11) and onto the boss of the pivot rod plate.
7. Install the ball stud bolt (16) through the pivot rod (6) and pivot support bearing (9). Secure these parts with nut (10) and tighten to 50 in-lb (5.5 N·m).
8. Install the accelerator rod assembly (17, 18 and 19).
9. Adjust the accelerator pedal and accelerator rod. **See Accelerator Pedal Adjustment on page 5-6. See following NOTE.**

**NOTE:** For proper vehicle operation, it is important that the accelerator pedal, governor linkage, and throttle adjustments are done correctly and in the proper sequence. **See Engine Control Linkage, Section 14, Page 14-6.**

10. Connect battery and spark plug wire(s). **See Connecting The Battery on page 1-3.**

## ACCELERATOR PEDAL ADJUSTMENT

**See General Warning, Section 1, Page 1-1.**

1. Measure the distance from the top of the accelerator pedal to the floorboard. If it is within the range of 5-3/4 inches  $\pm 1/4$  inch (14.6 cm  $\pm 6$  mm) (**Figure 5-7, Page 5-7**), adjusting the accelerator pedal is not necessary. Tighten the nylon locknut (23) to 26 ft-lb (35.3 N·m) (**Figure 5-11, Page 5-9**) and proceed to step 8. If adjustment is necessary, proceed to step 2.
2. Make sure the key switch is OFF and the Forward/Reverse handle is in the NEUTRAL position. Remove the key. Chock the wheels. **See following WARNING.**

### **⚠ WARNING**

- **Disconnect both battery cables, negative (–) cable first.**
3. Disconnect battery and spark plug wire(s). **See Disconnecting The Battery on page 1-3.**
  4. Loosen the nut and bolt securing the accelerator pedal to the pivot plate (**Figure 5-8, Page 5-7**).
  5. Use an accelerator pedal adjustment tool to make adjustment:
    - 5.1. Clamp the accelerator pedal adjustment tool (CC P/N 101871001) to the accelerator pedal, with the end marked **accelerator pedal height** closest to the floorboard (**Figure 5-9, Page 5-7**).
    - 5.2. Press the accelerator pedal until the end of the tool rests against the floorboard. Hold pedal in position against the floorboard with a rubber strap and tighten nut to 26 ft-lb (35.3 N·m).
  6. Use a tape measure to make adjustment.
    - 6.1. Adjust the distance from the floormat to the back of the accelerator pedal to be 5-3/4 inches  $\pm 1/4$ -inch (14.6 cm  $\pm 6$  mm) (**Figure 5-7, Page 5-7**). Tighten nut to 26 ft-lb (35.3 N·m) (**Figure 5-8, Page 5-7**).



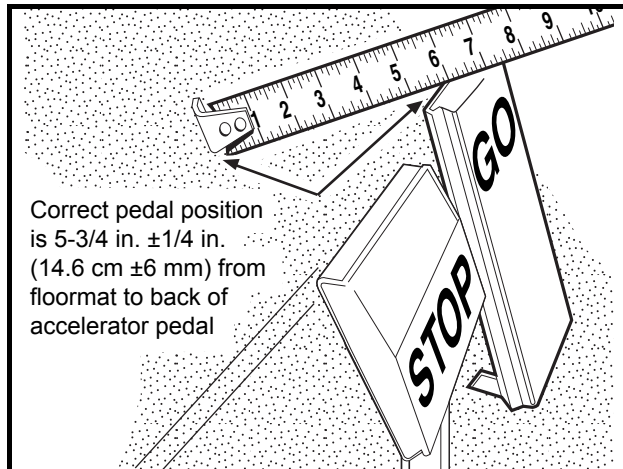


Figure 5-7 Accelerator Pedal Height

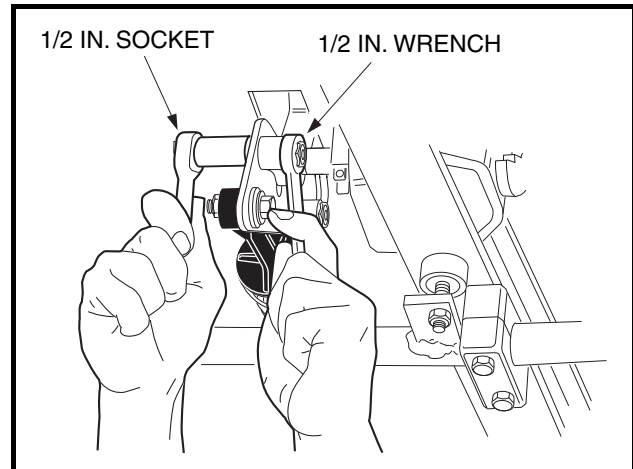


Figure 5-8 Accelerator Pedal Adjustment

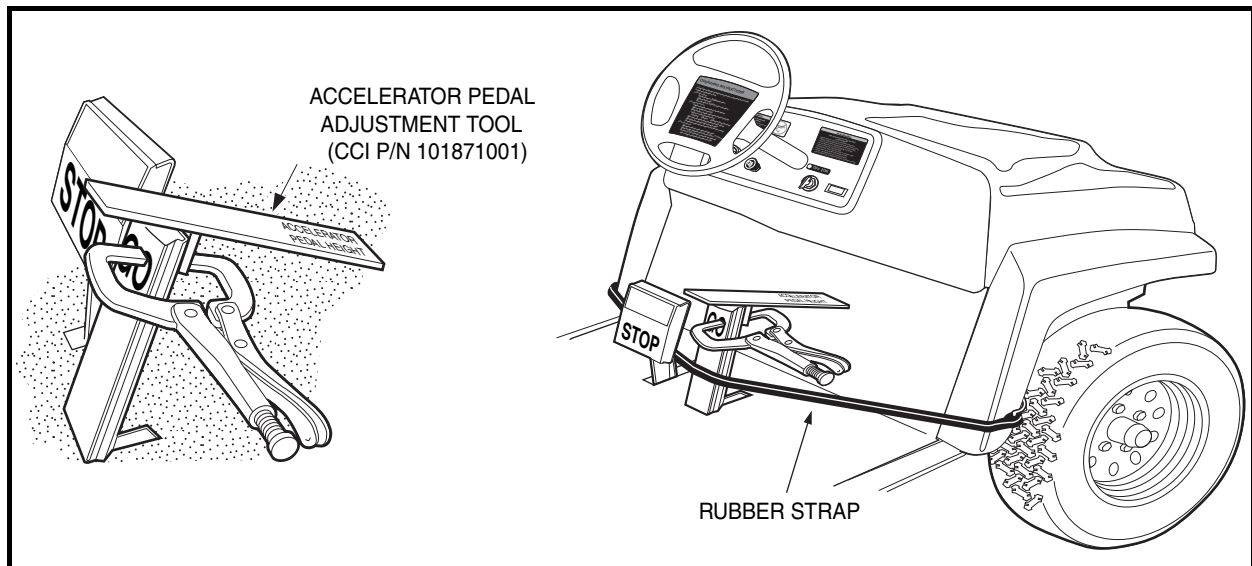


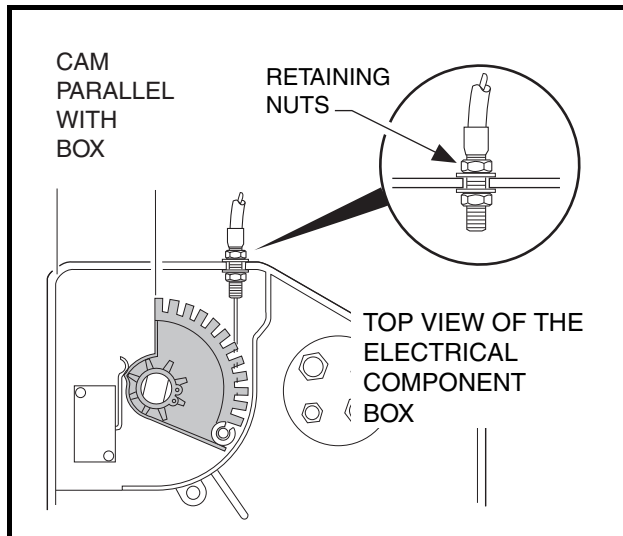
Figure 5-9 Accelerator Pedal Height Adjustment

#### 7. Adjust the accelerator rod.

- 7.1. Remove the electrical box screw and cover (Figure 5-10, Page 5-8). See the preceding **WARNING**.
- 7.2. Loosen the jam nuts (18) and disconnect the accelerator rod (17) at the accelerator pedal (Figure 5-11, Page 5-9). Adjust the length of the rod so the indicated cam edge is parallel with the edge of the electrical component box (Figure 5-10, Page 5-8). See following **CAUTION**.

### **CAUTION**

- After accelerator rod adjustment, make sure approximately the same amount of thread is exposed at each end of the rod.
- If lever on the limit switch in the electrical box is bent, replace limit switch.
- When loosening jam nuts on the accelerator rod with one end disconnected, hold the disconnected accelerator rod with locking pliers.
- When tightening jam nuts on the accelerator rod, hold the disconnected ball joint with locking pliers.

**Accelerator Pedal Adjustment Continued:**

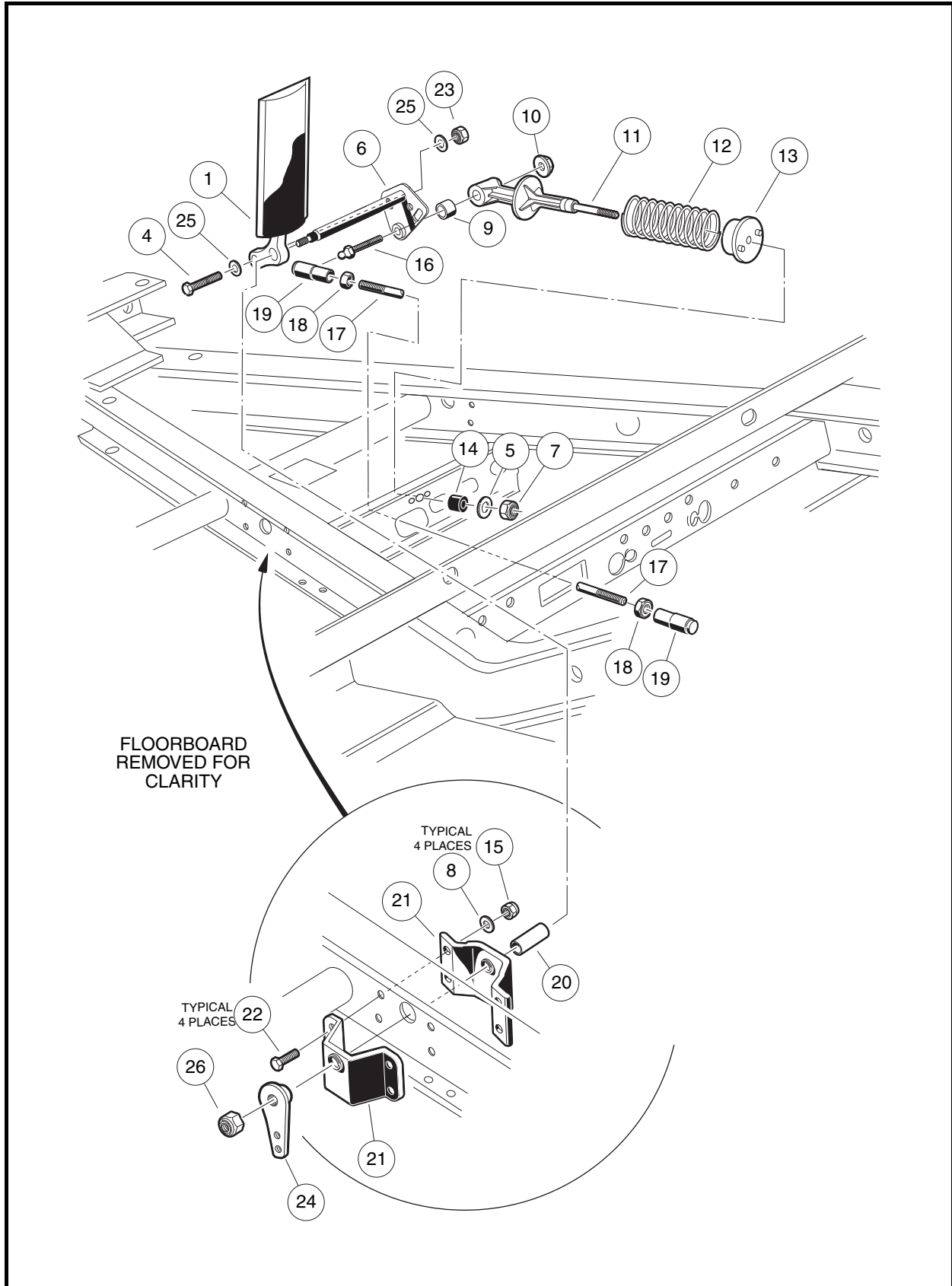
**Figure 5-10 Accelerator Cable and Electrical Box**

8. Connect the accelerator rod at the accelerator pedal (**Figure 5-11, Page 5-9**).
  - 8.1. Before tightening jam nuts on accelerator rod, press accelerator pedal and make sure the carburetor throttle actuates when the cam moves approximately 8° to 12° (**Figure 5-10, Page 5-8**). **See following NOTE.**

**NOTE:** After the accelerator pedal and rod are adjusted, the final governed engine RPM should be set to:  
 FE400 Engine: 3850 (±30) RPM

**See Engine RPM Adjustment, Section 14, Page 14-10.**

- 8.2. Hold the ball joint at each end of the accelerator rod (17) with pliers and tighten the accelerator rod jam nuts (18) against each ball joint (**Figure 5-11, Page 5-9**).
  - 8.3. Install the electrical box cover and screw and tighten to 18 in-lb (2 N·m).
9. Connect battery and spark plug wire(s). **See Connecting The Battery on page 1-3.**



FLOORBOARD  
REMOVED FOR  
CLARITY

Figure 5-11 Accelerator Pedal Assembly



# SECTION 6 – MC012C-BS00 TRANSAXLE: HYDRAULIC AND PARK BRAKE SYSTEMS

---

## **⚠ DANGER**

- See General Warning, Section 1, Page 1-1.

## **⚠ WARNING**

- See General Warning, Section 1, Page 1-1.

## **BRAKE SYSTEM INSPECTION**

---

**See General Warning, Section 1, Page 1-1.**

The hydraulic brake system and park brake system should be inspected immediately after any service to either of the brake systems.

### **Brake Pedal Inspection**

- When driving the vehicle and pressing the brake pedal, the vehicle should come to a smooth, straight stop.
- Apply and release the brake pedal several times. If noise or binding occurs, the brake pedal or hydraulic brake system may be in need of service. Pedal movement should be smooth, and when the pedal is released, it should return quickly and quietly.
- Move the brake pedal from side to side to check for worn parts. Excessive side movement indicates worn or loose pedal mounting parts. If worn parts are found, replace the worn parts, then adjust the brake pedal. **See Brake Pedal Adjustment, Section 5, Page 5-3.**
- Apply heavy pressure to the pedal and check for sponginess and excessive pedal travel. The pedal should be firm, and the back of the brake pedal should be a minimum of 2 inches from the floor. If the brake pedal feels “spongy”, perform the brake bleeding procedure. **See Bleeding the Hydraulic Brake System on page 6-31.**
- Hold the brake pedal pressed with medium foot pressure (25 to 35 lb. (111 to 156 N)) for 15 seconds. The pedal should not continue dropping when pressed with a steady amount of pressure. If the pedal goes to the floor, inspect the hydraulic system for leaks and repair any worn or damaged components. After repair, bleed the hydraulic brake system. **See Bleeding the Hydraulic Brake System on page 6-31.**

### **Master Cylinder Inspection**

- Inspect the exterior of the master cylinder. Replace any leaking components and bleed the hydraulic brake system. **See Bleeding the Hydraulic Brake System on page 6-31.**
- Check the brake fluid level. **See Brake Fluid on page 10-4.**
- Remove the reservoir cap and inspect the brake fluid. If brake fluid is contaminated, purge the brake fluid and refill the hydraulic system. **See Filling the Hydraulic System on page 6-32.**
- Check the vent holes in the reservoir cap and clean or replace as necessary.
- Check the diaphragm inside the reservoir cap and replace if damaged.

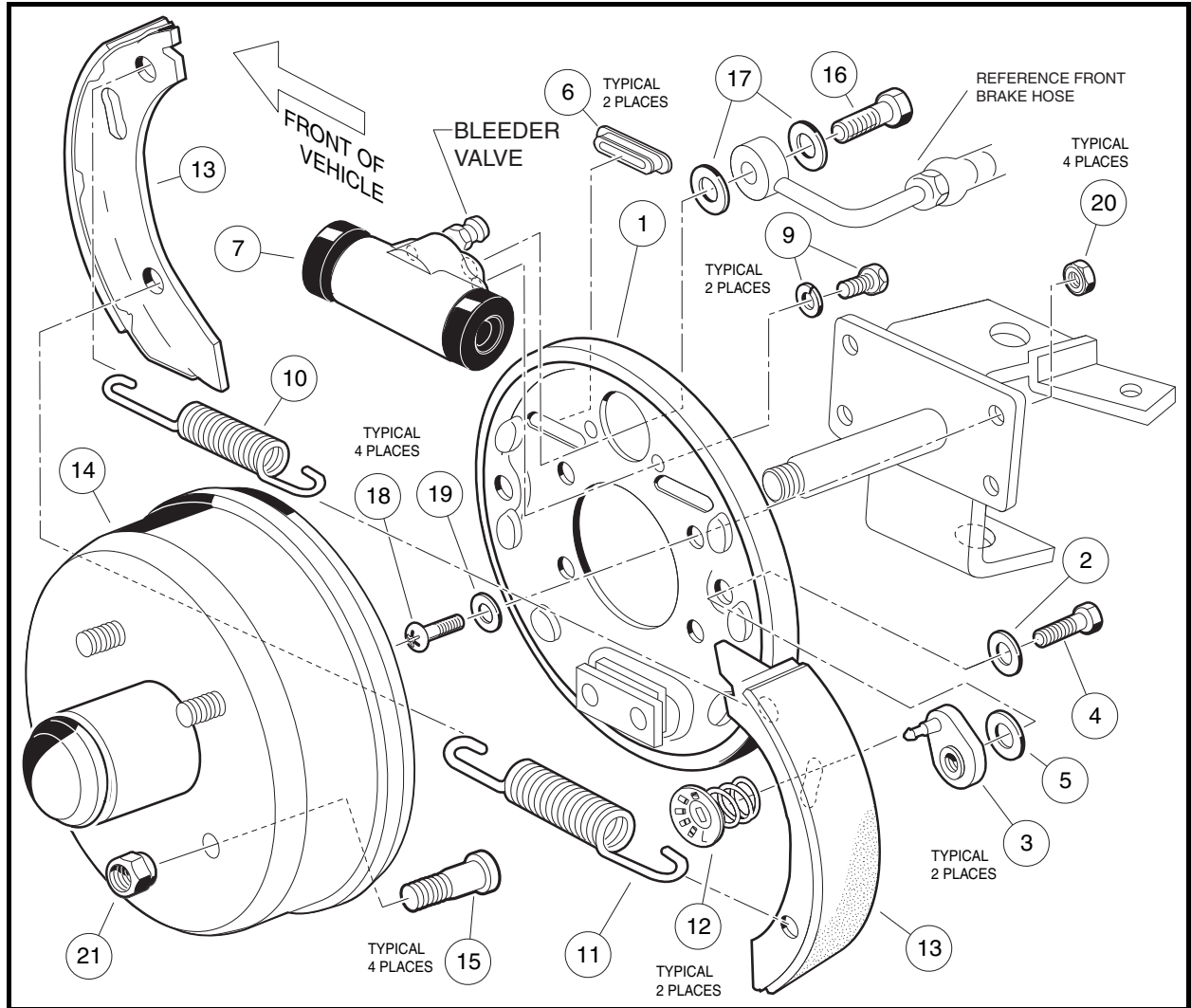


Figure 6-1 Front Hydraulic Brake Cluster Assembly

### Brake Line and Hose Inspection

- Inspect the brake lines for leakage from the brake lines or fittings. Replace as needed. **See Hydraulic Line and Hose Replacement on page 6-23.**
- Brake hoses must be flexible and free from leaks, cuts, cracks or bulges. Replace as necessary. **See Hydraulic Line and Hose Replacement on page 6-23.**
- Turn the steering wheel all the way from left to right and back again. Contact between brake hoses and any components, especially the wheels or tires, will damage brake hoses.
- Check the back side of each brake cluster backing plate for signs of brake fluid leakage. If so, determine the cause of the leak and replace the brake hose or wheel cylinder. **See Wheel Cylinder Replacement on page 6-19. Also See Hydraulic Line and Hose Replacement on page 6-23.**

### Park Brake Inspection

- Apply moderate pressure to the park brake handle. When latched, the park brake should lock the wheels and hold the vehicle stationary (on incline of 20% or less). If not adjust the park brake. **See Park Brake Adjustment on page 6-35.**
- Check the park brake cables, equalizer and linkage for damage. The cables should not come in contact with either of the rear wheels or tires.

## Brake Drum and Shoe Inspection

- Remove and inspect each brake drum. The drum should not be cracked, warped or have excessive scores or heat checks.
- Inspect the brake shoes. Shoes should not be distorted, cracked or have broken welds.
- Check the condition of the brake shoe linings. The brake shoe lining should not be glazed or soiled with grease or brake fluid. There should be a minimum of 1/32-inch (0.8 mm) of usable lining remaining at the thinnest point.

### **⚠ WARNING**

- Use only approved replacement brake drums designed for your vehicle. For MC012C-BS00 transaxles, use CC P/N 102264701.

## Brake Cluster Assembly Inspection

- Check each wheel cylinder (7) by pulling back the edge of each dust boot (**Figure 6-1, Page 6-2 or Figure 6-19, Page 6-21**). Brake fluid in the boot indicates a leaking wheel cylinder and should be replaced. **See Wheel Cylinder Replacement on page 6-19.**
- Inspect the shoe hold-down parts and springs. Replace damaged items.
- If the brake adjusters (3) are frozen (requiring more than 65 in-lb (7.4 N·m) to turn freely), worn or loose, replace the adjuster assemblies in pairs (**Figure 6-1, Page 6-2**). **See Brake Shoe Adjuster Replacement, Section 6, Page 6-21.**

## BRAKE SYSTEM TROUBLESHOOTING

The procedures used in making the checks provided in the following troubleshooting guide can be found in the referenced sections of this maintenance and service manual.

TROUBLESHOOTING GUIDE		
SYMPTOM	POSSIBLE CAUSES	CORRECTIVE ACTION
Low pedal – Pedal may go to the floor	Excessive clearance between the drums and shoe linings	Front - Perform step 19 of Front Wheel Brake Drum Installation on page 6-15. Rear - Perform step 4 of Rear Wheel Brake Drum Installation on page 6-16.
	Automatic adjusters are not working	Make several forward and reverse brake stops; if the pedal does not come up, replace the automatic adjusters. <b>See Brake Shoe Adjuster Replacement on page 6-21.</b>
	Bent or distorted brake shoes	Replace the brake shoes. <b>See Brake Shoe Removal on page 6-8.</b>
	Leak in the hydraulic system	Check the master cylinder, brake lines and hoses for leaks. Replace all damaged parts.
	Air in the hydraulic system	<b>See Bleeding the Hydraulic Brake System on page 6-31.</b>
Troubleshooting Guide continued on next page...		

<b>TROUBLESHOOTING GUIDE</b>		
<b>SYMPTOM</b>	<b>POSSIBLE CAUSES</b>	<b>CORRECTIVE ACTION</b>
<b>Low pedal – Pedal may go to the floor, continued</b>	Weak (bulging) brake hose	Replace the worn hose. <b>See Hydraulic Line and Hose Replacement on page 6-23.</b>
	Improperly adjusted master cylinder push rod	<b>See Brake Pedal Adjustment, Section 5, Page 5-3.</b>
<b>Springy or spongy brake pedal – Brake pedal has soft, springy or spongy feel when pressed</b>	Bent or distorted brake shoes	Replace the brake shoes. <b>See Brake Shoe Removal on page 6-8.</b>
	Cracked or thin drums	Replace brake drums. <b>See Brake Drum Removal on page 6-6.</b>
	Poor quality brake fluid (low boiling point)	Purge hydraulic fluid and fill with approved DOT 5 (silicone) brake fluid. <b>See Purging the Hydraulic System on page 6-32.</b>
	Weak (bulging) brake hoses that expand under pressure	Check the master cylinder, brake lines and hoses for leaks or bulges. Replace all damaged parts.
	Air in the hydraulic system	<b>See Bleeding the Hydraulic Brake System on page 6-31.</b>
<b>Hard pedal – Excessive pedal pressure is required to stop the vehicle</b>	Brake fade	Replace the brake shoes. <b>See Brake Shoe Removal on page 6-8.</b>
	Grease or brake fluid on the brake shoe linings	Replace hub or axle seal and replace the brake shoes. <b>See Brake Shoe Removal on page 6-8.</b>
	Glazed brake shoe linings	Replace the brake shoes. <b>See Brake Shoe Removal on page 6-8.</b>
	Damaged or distorted brake shoes	Replace the brake shoes. <b>See Brake Shoe Removal on page 6-8.</b>
	Scored or barrel-shaped brake drums	Replace the brake drums. <b>See Brake Drum Removal on page 6-6.</b>
	Clogged master cylinder lines or hoses	Replace brake lines or hoses as required. <b>See Hydraulic Line and Hose Replacement on page 6-23.</b>
	Frozen master cylinder piston	Replace master cylinder. <b>See Master Cylinder Removal on page 6-28.</b>
<b>Over-aggressive braking</b>	Incorrect or distorted brake shoes	Replace the brake shoes. <b>See Brake Shoe Removal on page 6-8.</b>
	Grease or brake fluid on the brake shoe linings	Replace hub, axle seal or wheel brake cylinder and replace brake shoes. <b>See Brake Shoe Removal on page 6-8.</b>
	Loose or distorted brake backing plate	Tighten or replace the back plate and/or hardware.
	Scored or warped brake drums	Replace the brake drums. <b>See Brake Drum Removal on page 6-6.</b>
	Corroded master cylinder bore	Replace master cylinder. <b>See Master Cylinder Removal on page 6-28.</b>
	Binding brake pedal linkage	Lubricate and adjust. <b>See Section 5 – Accelerator and Brake Pedal Assemblies.</b>
<b>Vehicle pulls to one side</b>	Incorrect or distorted brake shoes	Replace the brake shoes. <b>See Brake Shoe Removal on page 6-8.</b>
<b>Troubleshooting Guide continued on next page...</b>		



<b>TROUBLESHOOTING GUIDE</b>		
<b>SYMPTOM</b>	<b>POSSIBLE CAUSES</b>	<b>CORRECTIVE ACTION</b>
<b>Vehicle pulls to one side, continued</b>	Grease or brake fluid on the brake shoe linings	Replace hub, axle seal or wheel cylinder and replace the brake shoes. <b>See Brake Shoe Removal on page 6-8.</b>
	Loose or distorted brake cluster backing plate	Tighten or replace the backing plate and/or hardware.
	Scored or warped brake drums	Replace the brake drums. <b>See Brake Drum Removal on page 6-6.</b>
	Water on the brake shoe linings	Apply the brakes several times to dry the brake shoe linings.
	Sticking wheel cylinder piston	Replace the wheel cylinder. <b>See Wheel Cylinder Replacement on page 6-19.</b>
	Faulty suspension parts	<b>See Section 7 – Steering and Front Suspension or Section 9 – Rear Suspension.</b>
<b>Pulsating brake pedal</b>	Warped brake drums	Replace the brake drums. <b>See Brake Drum Removal on page 6-6.</b>
	Bent axle	Replace the axle. <b>See Section 16 – MC012C-BS00 Unitized Transaxle with Differential Lock.</b>
	Worn or damaged front wheel bearings	Replace bearings. <b>See Section 7 – Steering and Front Suspension.</b>
<b>Decreasing brake pedal travel</b>	Weak or broken brake shoe return springs	Replace return springs.
	Sticking wheel cylinder piston	Replace the wheel cylinder. <b>See Wheel Cylinder Replacement on page 6-19.</b>
	Overly adjusted brake adjusters	Adjust brake adjusters. <b>See Brake Shoe Adjuster Replacement on page 6-21.</b>
	Improperly adjusted park brake	Adjust park brake. <b>See Park Brake Adjustment on page 6-35.</b>
<b>Noise and chatter – Squealing, clicking or scraping sound upon brake application</b>	Bent, damaged or incorrect brake shoes	Replace the brake shoes. <b>See Brake Shoe Removal on page 6-8.</b>
	Worn out brake shoes	Replace the brake shoes. <b>See Brake Shoe Removal on page 6-8.</b>
	Foreign material embedded in brake shoe linings	Replace the brake shoes. <b>See Brake Shoe Removal on page 6-8.</b>
	Broken brake shoe return springs or hold down springs	Replace damaged parts.
	Rough, grooved or dry brake shoe edges or backing plate bosses	Lubricate the bosses of the brake cluster backing plate, and/or replace the brake shoes. <b>See Brake Cluster Inspection and Cleaning on page 6-10. See Brake Shoe Removal on page 6-8.</b>
	Brake drums are cracked or scored	Replace the brake drums. <b>See Brake Drum Removal on page 6-6.</b>
<b>All brakes drag</b>	Binding brake pedal	Lubricate and adjust. <b>See Section 5 – Accelerator and Brake Pedal Assemblies.</b>
	Soft or swollen rubber parts caused by incorrect or contaminated brake fluid	Replace master cylinder. <b>See Master Cylinder Removal on page 6-28.</b>
<b>Troubleshooting Guide continued on next page...</b>		

TROUBLESHOOTING GUIDE		
SYMPTOM	POSSIBLE CAUSES	CORRECTIVE ACTION
Rear brakes drag	Binding park brake cables	Adjust or replace cables and adjust.
	Improper brake adjustment	Adjust shoes and repair the brake shoe adjusters if necessary. <b>See Brake Cluster Inspection and Cleaning on page 6-10.</b>
One brake drags	Weak or broken brake shoe return springs	Replace the return springs.
	Improper brake shoe adjustment	Adjust shoes and repair the brake shoe adjusters if necessary. <b>See Brake Cluster Inspection and Cleaning on page 6-10.</b>
	Sticking wheel cylinder pistons	Replace the wheel cylinder. <b>See Wheel Cylinder Replacement on page 6-19.</b>
	Swollen wheel cylinder cups	Replace the wheel cylinder and purge the hydraulic system. <b>See Wheel Cylinder Replacement on page 6-19 and Purging the Hydraulic System on page 6-32.</b>
	Bent or distorted brake shoes	Replace the brake shoes. <b>See Brake Shoe Removal on page 6-8.</b>
	Loose or worn front wheel bearings	Adjust or replace front wheel bearings. <b>See Section 7 – Steering and Front Suspension.</b>
	Damaged brake line or hydraulic line	Replace brake lines or tubes as required. <b>See Hydraulic Line and Hose Replacement on page 6-23.</b>

## BRAKE DRUM REMOVAL

See General Warning, Section 1, Page 1-1.

### FRONT WHEEL BRAKE DRUM REMOVAL

#### **⚠ WARNING**

- If at any point in this procedure the hydraulic system is opened, the brakes must be bled after the correct installation of the brake components. Failure to bleed the brakes could result in decreased braking performance due to air being trapped in the hydraulic system. Use only DOT 5 brake fluid. See Bleeding the Hydraulic Brake System on page 6-31.
1. Chock the rear wheels, release the park brake, loosen the front wheel lug nuts and lift the front of the vehicle with a chain hoist or floor jack. **See WARNING “Lift only one end...” in General Warning, Section 1, Page 1-2.**
  2. Place jack stands under the outer front frame I-beams and lower onto stands. **See Figure 5-2, Section 5, Page 5-3.**
  3. Remove the lug nuts and front wheel.
  4. Remove the front wheel brake drum.
    - 4.1. Remove the dust cover (1) and cotter pin (2) (**Figure 6-2, Page 6-7**).
    - 4.2. Remove the castle nut (3), large flat washer (4), wheel bearing (5) and drum (8). If the brake drum was easily removed, proceed to step 6.

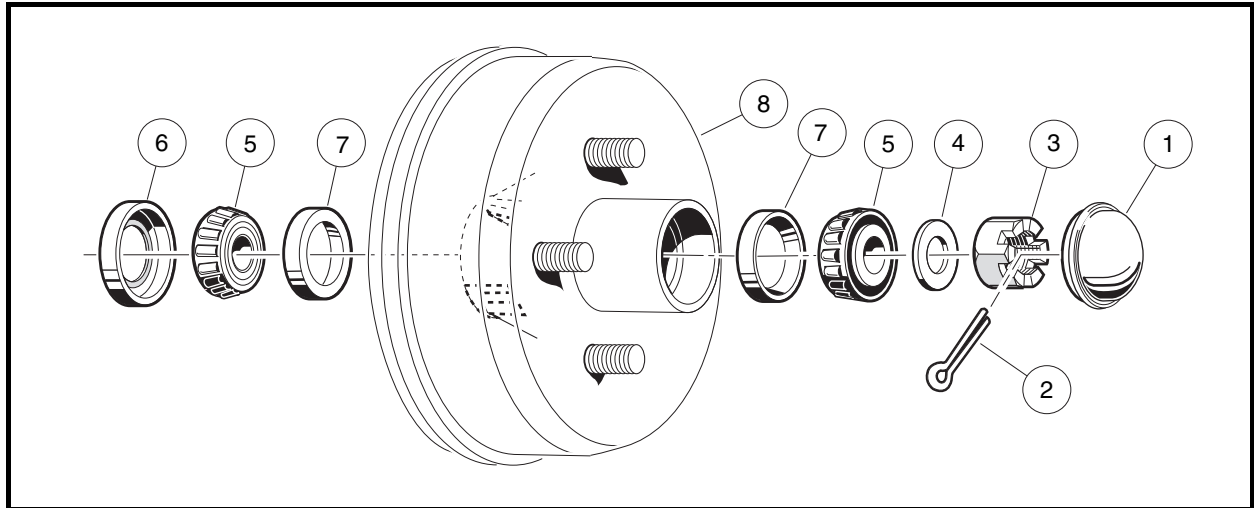


Figure 6-2 Front Spindle and Brake Drum Assembly

5. To remove tight brake drums:

- 5.1. On the back of each brake cluster assembly, locate the heads of the two brake shoe adjusters.
- 5.2. Use a torque wrench and a Torx #T-27 driver, or hydraulic brake adjuster (CC P/N 102169401), and gently rotate the adjuster bolts to increase the clearance between the brake shoe lining and the brake drum (**Figure 6-3, Page 6-7**). See following **NOTE**.

**NOTE:** If the adjusters require more than 65 in-lb (7.3 N·m) of force to rotate, they must be replaced. See **Brake Shoe Adjuster Replacement on page 6-21**.

6. Repeat steps 1 through 6 for the opposite front wheel if necessary.

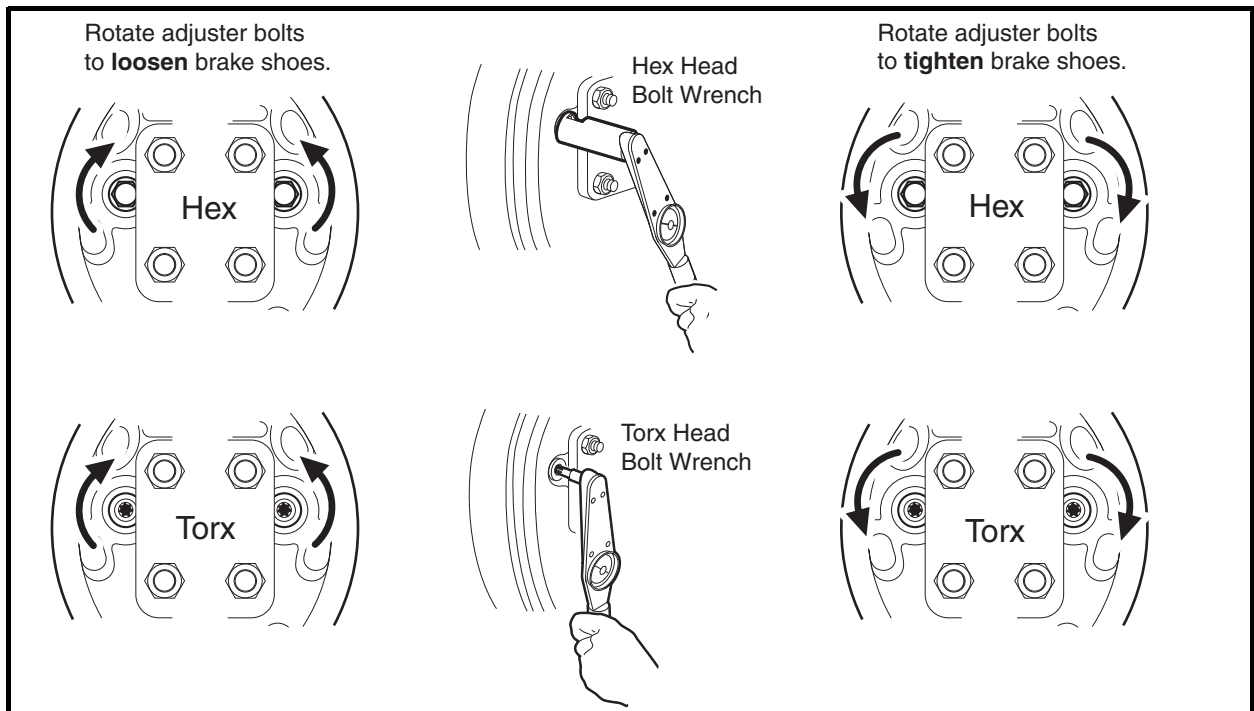


Figure 6-3 Loosen or Tighten Brake Adjusters

## REAR WHEEL BRAKE DRUM REMOVAL

### **⚠ WARNING**

- Use only approved replacement brake drums designed for your vehicle. For MC012C-BS00 transaxles, use CC P/N 102264701.
1. Place chocks at the front wheels, release the park brake, loosen the rear wheel lug nuts and lift the rear of the vehicle with a chain hoist or floor jack. **See WARNING “Lift only one end...” in General Warning, Section 1, Page 1-2.**
  2. Place jack stands under the axle tubes and lower onto stands.
  3. Remove the lug nuts and remove rear wheel.
  4. Remove the brake drum. If the brake drum was easily removed, proceed to step 6.
  5. To remove tight brake drums:
    - 5.1. On the back of each brake cluster assembly, locate the bolt heads of the two brake shoe adjusters.
    - 5.2. Use a torque wrench and a Torx #T-27 driver, or hydraulic brake adjuster (CC P/N 102169401), and gently rotate the adjuster bolts to increase the clearance between the brake shoe lining and the brake drum (**Figure 6-3, Page 6-7**). **See following NOTE.**

**NOTE:** *If the adjusters require more than 65 in-lb (7.3 N·m) of force to rotate, they must be replaced. See Brake Shoe Adjuster Replacement on page 6-21.*

- 5.3. Rotate the brake drum slightly to remove it from the brake shoe cluster assembly.
6. Repeat steps 3 through 5 for the opposite rear wheel if necessary.

## BRAKE SHOE REMOVAL

See General Warning, Section 1, Page 1-1.

### **⚠ WARNING**

- If at any point in this procedure the hydraulic system is opened, the brakes must be bled after the correct installation of the brake components. Failure to bleed the brakes could result in decreased braking performance due to air being trapped in the hydraulic system. Use only DOT 5 brake fluid. See Bleeding the Hydraulic Brake System on page 6-31.

## FRONT BRAKE SHOE REMOVAL

1. Remove the brake drum. **See Front Wheel Brake Drum Removal on page 6-6.**
2. Use pliers or a brake tool to rotate the cup washer and compression spring assembly 90° and remove the cup and spring from each brake shoe (**Figure 6-4, Page 6-9**). **See following NOTE.**

**NOTE:** *The brake shoes are under spring tension and can release suddenly when cup and spring assemblies are removed.*

3. Pull brake shoes and tensioning springs from the brake cluster assembly (**Figure 6-7, Page 6-9**).
4. Repeat steps 1 and 3 for the opposite front wheel if necessary.

## REAR BRAKE SHOE REMOVAL

1. Remove the brake drum. **See Rear Wheel Brake Drum Removal on page 6-8.**

**NOTE:** It is recommended that the wheel bolt flange (22) be removed prior to brake shoe removal (Figure 6-5, Page 6-9).

2. Remove rubber boot (26), cotter pin (25), locking cap (27) and large flat washer (23) (Figure 6-5, Page 6-9).
3. Remove the flanged nut (24) and large flat washer (23) from the axle end.
4. Slide the wheel bolt flange (22) off of the splined axle end.
5. Use pliers or a brake tool to rotate the cup washer and compression spring assembly 90° and remove the cup and spring from each brake shoe (Figure 6-6, Page 6-9).

**NOTE:** The brake shoes are under spring tension and can release suddenly when cup and spring assemblies are removed.

6. Pull brake shoes and tensioning springs from the brake cluster assembly (Figure 6-7, Page 6-9).
7. Repeat steps 1 through 6 for the opposite rear wheel if necessary.

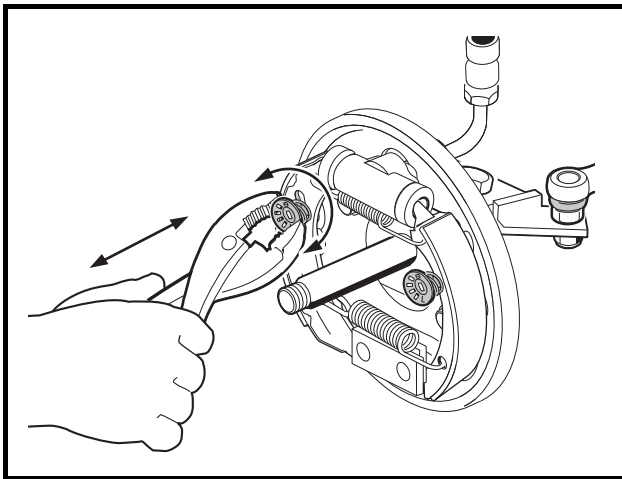


Figure 6-4 Rotate Front Spring Cups

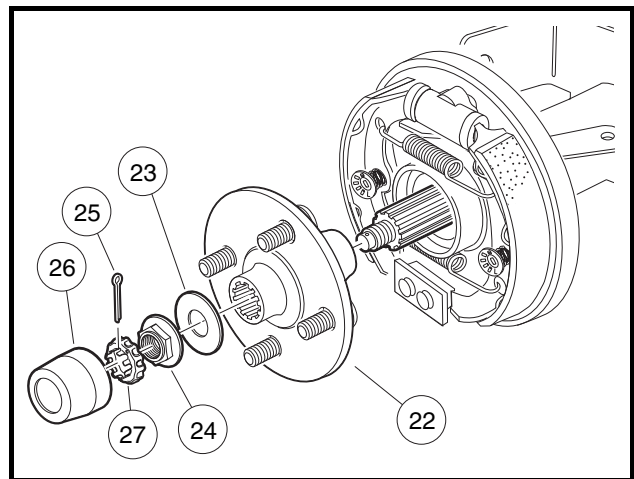


Figure 6-5 Rear Wheel Bolt Flange Assembly

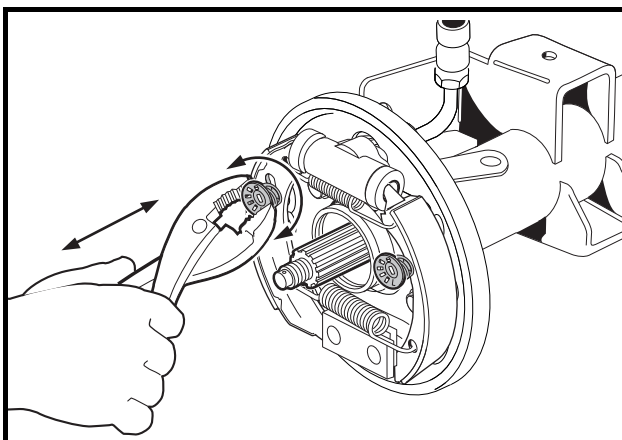


Figure 6-6 Rotate Rear Spring Cups

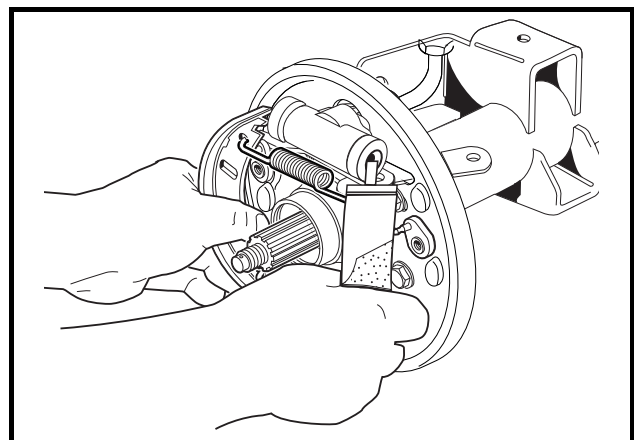


Figure 6-7 Remove Brake Shoes

## BRAKE CLUSTER INSPECTION AND CLEANING

See General Warning, Section 1, Page 1-1.

### **⚠ WARNING**

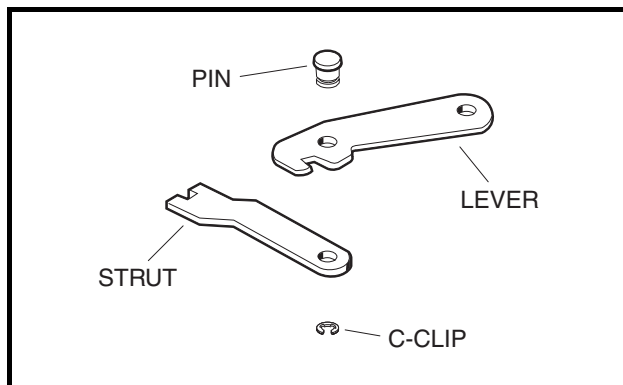
- If at any point in this procedure the hydraulic system is opened, the brakes must be bled after the correct installation of the brake components. Failure to bleed the brakes could result in decreased braking performance due to air being trapped in the hydraulic system. Use only DOT 5 brake fluid. See Bleeding the Hydraulic Brake System on page 6-31.

**NOTE:** Factory installed brake shoes have non-asbestos linings (CC P/N 102050201). When replacing brake shoes, Club Car, LLC, recommends non-asbestos replacement parts.

1. Remove the brake drum. See **Front Wheel Brake Drum Removal on page 6-6, and Rear Wheel Brake Drum Removal on page 6-8.**
2. Remove the brake shoes. See **Front Brake Shoe Removal on page 6-8, and Rear Brake Shoe Removal on page 6-8.**
3. Clean the brake cluster back plate and all of the brake cluster components.
4. Check the brake shoe adjusters in each brake cluster assembly for proper operation.
  - 4.1. Locate the bolt heads of the two brake shoe adjusters on the back of each brake cluster assembly.
  - 4.2. Use a torque wrench and a Torx #T-27 driver, or hydraulic brake adjuster (CC P/N 102169401), and gently rotate the adjuster bolts (**Figure 6-2, Page 6-7**). See **following NOTE**.

**NOTE:** If the adjusters require more than 65 in-lb (7.3 N·m) of force to rotate, they must be replaced. See **Brake Shoe Adjuster Replacement on page 6-21.**

5. Check the wheel cylinder for signs of leakage and replace if necessary. See **Wheel Cylinder Replacement on page 6-19.**
6. Check all springs for loss of compression, tension, or damage and replace if necessary.
7. Check each brake cluster assembly for signs of excessive wear or damage and replace if necessary. See **Brake Cluster Assembly Replacement on page 6-17.**



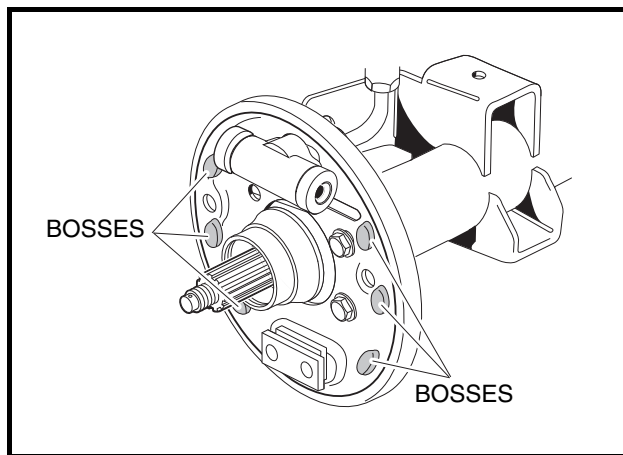
**Figure 6-8 Park Brake Lever and Strut**

8. Ensure that the park brake lever and strut assembly (14) can be easily moved by hand (**Figure 6-19, Page 6-21**). If so proceed to step 10. If not proceed to step 9.
9. Clean and lubricate the rear park brake lever and strut.
  - 9.1. Remove the park brake cable hair spring clip (1), hair spring cotter pin (2), and clevis pin (3) from the cable clevis and strut (**Figure 6-16, Page 6-18**).
  - 9.2. Remove the lever and strut (14) from the brake cluster assembly (**Figure 6-19, Page 6-21**).

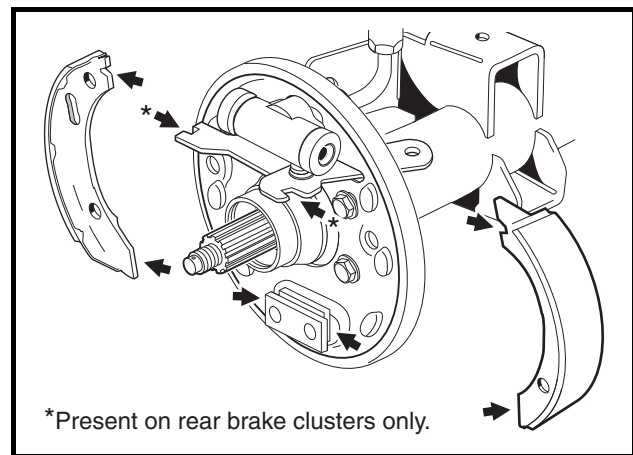
- 9.3. Disassemble the lever and strut by removing the C-clip and pin (**Figure 6-8, Page 6-10**).
- 9.4. Use a wire brush to remove corrosion and contaminants from the contact areas of the strut and lever.
- 9.5. Brush a light coat of white lithium NLGI Number 2 grease (Dow Corning® BR2-Plus or equivalent) on the pin and contact surfaces and assemble the lever and strut. **See following WARNING.**

### **⚠ WARNING**

- **Make sure the C-clip is properly seated in the groove of the pin. An improperly installed C-clip could result in a non-functioning park brake.**
- **Apply grease carefully when performing the following steps. Do not allow any grease to get on the friction surfaces of the brake shoe pads. Failure to heed this warning could cause diminished brake performance, possibly resulting in property damage or severe personal injury.**



**Figure 6-9 Lubricate Raised Bosses**



**Figure 6-10 Lubricate Rear Brake Cluster**

10. Brush a light coat of white lithium NLGI Number 2 grease (Dow Corning BR2-Plus or equivalent) on each of the six raised bosses on the back plate (**Figure 6-9, Page 6-11**). **See preceding WARNING.**
11. Brush a light coat of white lithium NLGI Number 2 grease (Dow Corning BR2-Plus or equivalent) to each end of both brake shoes and into the slots in the brake shoe mounting block. Apply grease to the notches in the mechanical park brake mechanism (**Figure 6-10, Page 6-11**). **See preceding WARNING.**
12. Repeat steps 1 through 11 for the remaining brake cluster assemblies if necessary.

## **BRAKE SHOE INSTALLATION**

**See General Warning, Section 1, Page 1-1.**

### **⚠ WARNING**

- **If at any point in this procedure the hydraulic system is opened, the brakes must be bled after the correct installation of the brake components. Failure to bleed the brakes could result in decreased braking performance due to air being trapped in the hydraulic system. Use only DOT 5 brake fluid. See Bleeding the Hydraulic Brake System on page 6-31. See following NOTE.**

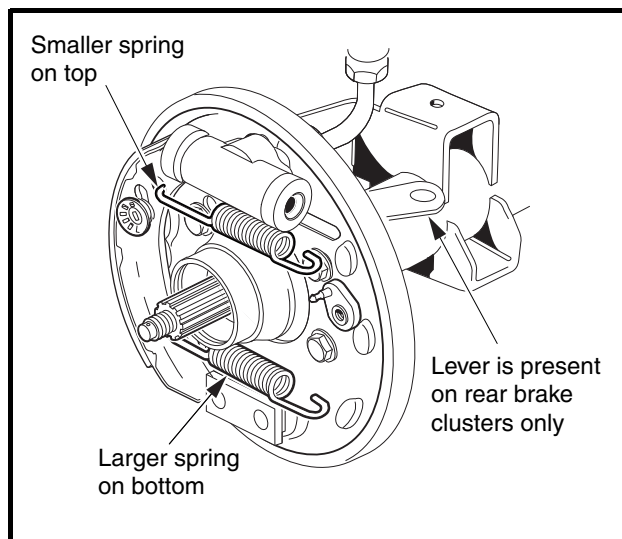
**NOTE:** This vehicle uses a pair of identical brake shoes in each front and rear brake cluster. Each shoe must be positioned so that the adjuster pin is inserted into the slot of the brake shoe (**Figure 6-11, Page 6-12**).

## FRONT BRAKE SHOE INSTALLATION

1. Install one shoe onto the back plate, positioning the bottom tip of the shoe into the brake shoe mounting block, and the top tip of the shoe into the wheel cylinder piston.
2. Compress the spring with the cup washer (12) onto the pin of the adjuster assembly (3) (**Figure 6-1, Page 6-2**) and rotate 90° to secure the brake shoe (**Figure 6-6, Page 6-9**).
3. Attach the tensioning springs onto the shoe with the smaller spring on top and the larger spring on the bottom.
4. Position the bottom tip of the remaining shoe into the mounting block and the top tip into the slot in the wheel cylinder piston. Attach the free ends of the tensioning springs to the loose shoe and push the shoe into place.
5. Compress the remaining spring and cup washer (12) onto the pin of the adjuster (3) (**Figure 6-1, Page 6-2**) and rotate 90° to secure the brake shoe (**Figure 6-4, Page 6-9**).
6. After the shoes are installed, move them together up and down approximately 1/4 to 3/8-inch (6.3 to 9.5 mm) to make sure that they will slide easily without binding (**Figure 6-13, Page 6-13**).
7. Install the front wheel brake drum. **See Front Wheel Brake Drum Installation on page 6-14.**
8. Repeat steps 1 through 7 for the remaining front wheel if necessary.
9. Bleed the front brakes as instructed. **See Bleeding the Hydraulic Brake System on page 6-31.**
10. Perform all of the brake system inspections. **See Brake System Inspection on page 6-1.**

## REAR BRAKE SHOE INSTALLATION

1. Install one shoe onto the back plate, positioning the bottom tip of the shoe into the brake shoe mounting block, and the top tip into the wheel cylinder piston.
2. Compress the spring with the cup washer (12) onto the pin of the adjuster assembly (3) (**Figure 6-19, Page 6-21**) and rotate 90° to secure the brake shoe (**Figure 6-6, Page 6-9**).
3. Attach the tensioning springs onto the shoe with the smaller spring on top and the larger spring on the bottom (**Figure 6-11, Page 6-12**).



**Figure 6-11 Brake Shoe Tensioning Springs**



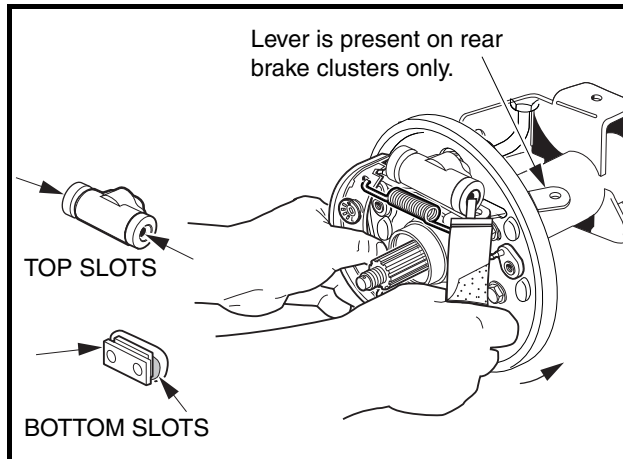


Figure 6-12 Brake Shoe Installation

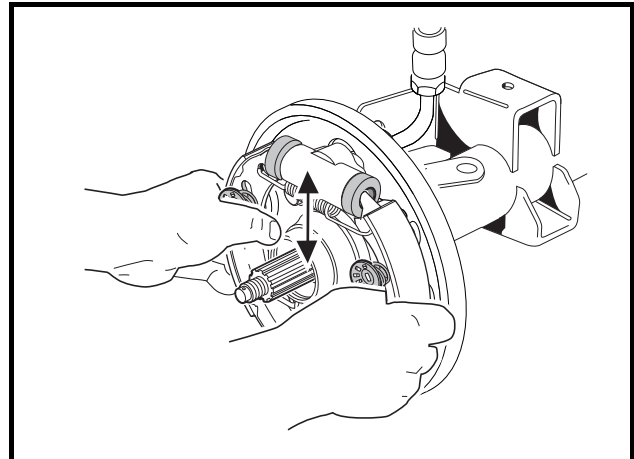


Figure 6-13 Slide Brake Shoes

4. Position the bottom tip of the remaining shoe into the mounting block and the top tip into the slot in the wheel cylinder piston. Attach the free ends of the tensioning springs to the loose shoe and push the shoe into place (**Figure 6-12, Page 6-13**).
5. Compress the remaining spring and cup washer (12) onto the pin of the adjuster (3) (**Figure 6-19, Page 6-21**) and rotate 90° to secure the brake shoe (**Figure 6-6, Page 6-9**).
6. After installation, move brake shoes up and down to make sure that they will slide easily approximately 1/4 to 3/8-inch (6.3 to 9.5 mm) without binding (**Figure 6-13, Page 6-13**).
7. Repeat steps 1 through 6 for the remaining rear wheel if necessary.
8. Install the wheel bolt flange. **See following NOTE.**

**NOTE:** Clean splined area in the wheel bolt flange and on the splined end of axle before installation. Use a small brush to carefully apply a light coat of white lithium NLGI Number 2 grease (Dow Corning BR2-Plus or equivalent) to both prior to assembly.

- 8.1. Slide wheel bolt flange (22) onto splined axle (**Figure 6-5, Page 6-9**).
- 8.2. Slide the large flat washer (23) onto the end of the axle and up against the wheel bolt flange. **See following NOTE.**

**NOTE:** It is recommended that a light film of white lithium NLGI Number 2 grease (Dow Corning BR2-Plus or equivalent) be applied to both surfaces of the large washer (23) before the flanged nut (24) is installed and torqued to specification.

- 8.3. Attach the flanged nut (24) and tighten to 150 ft-lb (203 N·m).
- 8.4. Install the locking nut cap (27) onto the flanged nut (24) and position the locking cap (27) to provide clear passage for a new cotter pin (25).
- 8.5. Install a new cotter pin (25) through the locking cap and axle, bending the split ends of the pin to secure the locking nut cap (27). **See following WARNING.**

### **⚠ WARNING**

- **Make sure to install and bend the cotter pin. Failure to bend the cotter pin could result in the separation of the wheel bolt flange from the splined end of the axle. Loss of vehicle control could result, causing severe personal injury.**

- 8.6. Install the rubber boot (26) onto the large washer (23). **See following NOTE.**

**Rear Brake Shoe Installation, Continued:**

**NOTE:** Push the rubber boot onto the washer so that the washer edge fits into the boot-lip groove.

9. Install rear wheel brake drum. **See Rear Wheel Brake Drum Installation on page 6-16.**
10. Repeat steps 8 through 9 for the remaining rear wheel if necessary.
11. Bleed the rear brakes as instructed. **See Bleeding the Hydraulic Brake System on page 6-31.**
12. Perform all of the brake system inspections. **See Brake System Inspection on page 6-1.**

**BRAKE DRUM INSTALLATION**

**See General Warning, Section 1, Page 1-1.**

** WARNING**

- If at any point in this procedure the hydraulic system is opened, the brakes must be bled after the correct installation of the brake components. Failure to bleed the brakes could result in decreased braking performance due to air being trapped in the hydraulic system. Use only DOT 5 brake fluid. **See Bleeding the Hydraulic Brake System on page 6-31.**
- Worn or damaged brake drums cannot be machined. Replace as necessary.
- Use only approved replacement brake drums designed for your vehicle. For MC012C-BS00 transaxles, use CC P/N 102264701.

**FRONT WHEEL BRAKE DRUM INSTALLATION**

**NOTE:** Prior to installing the brake drum, inspect the brake lines, hoses, drums and brake cluster assemblies. **See Brake System Inspection on page 6-1.**

Clean any residual grease from the friction area of the brake drum prior to installation.

1. Clean the wheel bearings (5) (**Figure 6-2, Page 6-7**). **See following NOTE.**

**NOTE:** Do not use compressed air to dry wheel bearings after cleaning. Spinning the wheel bearings at accelerated speeds, for purposes of drying, can damage bearings and bearing race.

2. Replace wheel bearings if they are damaged, pitted, or show signs of uneven wear areas. **See following NOTE.**

**NOTE:** If the wheel bearings must be replaced, new bearing cups must be provided. New bearing cups are only available as an assembled part of each wheel hub. Refer to the illustrated parts manual for replacement part number of the wheel hub (**Figure 6-2, Page 6-7**).

3. Inspect the bearing cups (7) for wear or damage. If they are worn or pitted they must be replaced, along with their respective wheel hub as an assembly.
4. Pack the wheel bearings (5) and bearing cups (7) with Chassis Lube (EP NLGI Grade 2). Force grease between the rollers.
5. Lubricate spindle shaft with grease.
6. Install a new seal (6) and grease packed wheel bearing (5) into rear of hub (8) (**Figure 6-2, Page 6-7**).
7. Carefully apply grease around the seal (6) inner lip before installation. Do not allow grease to touch the brake shoe linings nor the brake shoe surface of the drum hub.
8. Place the brake drum hub (8) onto the spindle and brake cluster assembly.

9. If the brake drum is difficult to push over the brake shoes, use the following procedure:
  - 9.1. Locate the bolt heads of the two brake shoe adjusters on the back of the brake cluster plates.
  - 9.2. Use a torque wrench and a Torx #27 driver, or hydraulic brake adjuster (CC P/N 102169401), and gently rotate the adjuster bolts to increase the clearance between the brake shoe lining and the brake drum (**Figure 6-14, Page 6-16**). **See following NOTE.**

**NOTE:** *If the adjusters require more than 65 in-lb (7.3 N·m) of force to rotate, they must be replaced. See **Brake Shoe Adjuster Replacement on page 6-21.***

10. Fill the brake drum hub cavity with grease.
11. Install the outside bearing (5) onto the spindle (**Figure 6-2, Page 6-7**).
12. Install the flat washer (4) up against the bearing race.
13. Install the castle nut (3) onto the spindle finger-tight.
14. Rotate the brake drum slowly while gently tightening the castle nut (3) until the drum hub and bearings are properly seated.
15. Tighten the castle nut (3) to 10 ft-lb (13.6 N·m) in order to fully seat the bearing and cup.
16. Loosen the castle nut 1/2 turn and retighten the nut to 14 in-lb (1.6 N·m).
17. Install a new cotter pin (2), bending the split ends of the pin to secure the castle nut (**Figure 6-2, Page 6-7**). **See following WARNING, CAUTION, and NOTE.**

### **⚠ WARNING**

- **Make sure to install and bend the cotter pin. Failure to bend the cotter pin could result in the separation of the wheel from the spindle. Loss of vehicle control could result, causing severe personal injury.**

### **⚠ CAUTION**

- **Use a new cotter pin when installing the drum/hub assembly.**

**NOTE:** *If the cotter pin does not line up with the hole in the spindle when the castle nut is properly tightened, rotate the castle nut back until the next available notch allows the cotter pin to be installed.*

18. Install the dust cover (1).
19. With the brake drum properly seated and secured, use a torque wrench with a Torx #T-27 driver, or hydraulic brake adjuster (CC P/N 102169401), and gently adjust the clearance between the brake shoes and brake drum by turning each of the two adjuster bolt heads on the back of the brake cluster plate (**Figure 6-14, Page 6-16**). **See following CAUTION.**

### **⚠ CAUTION**

- **Do not apply more than 65 in-lb (7.3 N·m) of torque to any of the adjuster bolts. Overtightening the adjuster bolts could result in damage to the brake cluster components or the separation of the bolt (4) from the adjuster (3) (**Figure 6-1, Page 6-2 or Figure 6-19, Page 6-21**).**

20. Install the wheel and finger-tighten the lug nuts (21).
21. Repeat steps 1 through 20 for the opposite front wheel if necessary.
22. Lower the vehicle and finish tightening the lug nuts, using a crisscross pattern, to 55 ft-lb (74.6 N·m) for steel wheels or 65 ft-lb (88 N·m) for alloy mag wheels.
23. Check the front wheel free play. **See Front Wheel Free Play Inspection, Section 7, Page 7-19.**
24. Perform all of the brake system inspections. **See Brake System Inspection on page 6-1.**

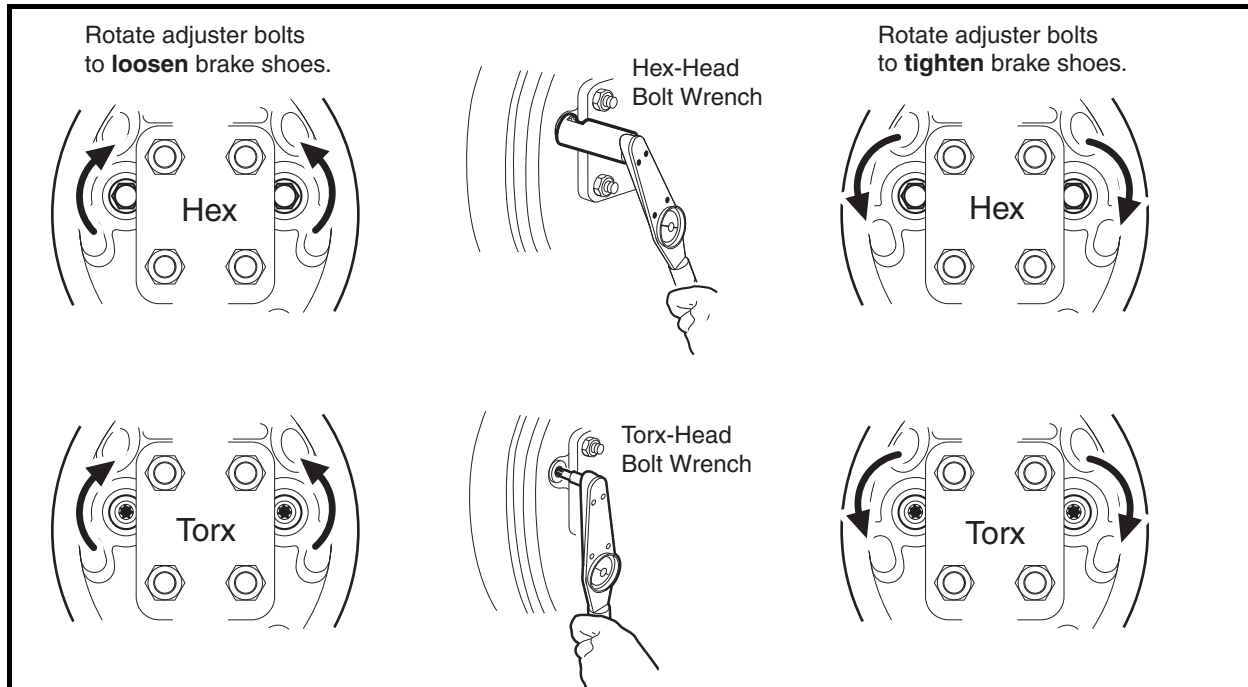


Figure 6-14 Loosen or Tighten Brake Adjusters

## REAR WHEEL BRAKE DRUM INSTALLATION

**NOTE:** Prior to installing the brake drum, inspect the brake lines, hoses, drums and brake cluster assemblies. See *Brake System Inspection* on page 6-1. See following **WARNING**.

### **WARNING**

- Use only approved replacement brake drums designed for your vehicle. For MC012C-BS00 transaxles, use CC P/N 102264701.
1. Place the brake drum (15) onto the wheel bolt flange and brake cluster (**Figure 6-19, Page 6-21**). See following **NOTE**.

**NOTE:** If brake drum installation is difficult, the brake shoes may need to be adjusted vertically in the mounting slots.

2. Use a torque wrench and a Torx #T-27 driver, or hydraulic brake adjuster (CC P/N 102169401), and gently rotate the adjuster bolts to increase the clearance between the brake shoe lining and the brake drum (**Figure 6-14, Page 6-16**). See following **NOTE**.

**NOTE:** If the adjusters require more than 65 in-lb (7.3 N·m) of force to rotate, they must be replaced. See *Brake Shoe Adjuster Replacement* on page 6-21.

3. Rotate and gently press the brake drum to ensure that the drum is properly seated.
4. With the brake drum properly seated and secured, gently adjust the clearance between the brake shoe lining and brake drum (**Figure 6-14, Page 6-16**). See following **CAUTION**.

### **CAUTION**

- Do not apply more than 65 in-lb (7.3 N·m) of torque to any of the adjuster bolts. Overtightening the adjuster bolts could result in damage to the brake cluster components or the separation of the bolt (4) from the adjuster (3) (**Figure 6-1, Page 6-2** or **Figure 6-19, Page 6-21**).

5. Install the wheel and finger-tighten the lug nuts (21) (**Figure 6-19, Page 6-21**).
6. Repeat steps 1 through 5 for the opposite rear wheel as required.
7. Lower the vehicle and finish tightening the lug nuts, using a crisscross pattern, to 55 ft-lb (74.6 N·m) for steel wheels or 65 ft-lb (88 N·m) for alloy mag wheels.
8. Perform all of the brake system inspections. **See Brake System Inspection on page 6-1.**

## BRAKE CLUSTER ASSEMBLY REPLACEMENT

See General Warning, Section 1, Page 1-1.

### **⚠ WARNING**

- To perform this procedure, the hydraulic system must be opened. As a result, the brakes must be bled after the correct installation of the brake components. Failure to bleed the brakes could result in decreased braking performance due to air being trapped in the hydraulic system. Use only DOT 5 brake fluid. See Bleeding the Hydraulic Brake System on page 6-31.
- Worn or damaged brake drums must not be machined. Replace as necessary.
- Use only approved replacement brake drums designed for your vehicle. For MC012C-BS00 transaxles, use CC P/N 102264701.

### FRONT BRAKE CLUSTER ASSEMBLY REMOVAL

1. Remove front wheel brake drum. **See Front Wheel Brake Drum Removal on page 6-6.**
2. Remove the banjo bolt (16) and copper washers (17) (**Figure 6-1, Page 6-2**).
3. Lift the hose above the brake cluster assembly and place a plastic bag over the hose fitting to keep dirt and debris from entering the hydraulic brake system (**Figure 6-15, Page 6-17**).
4. Using a Torx #T-40 driver and remove the four Torx-head bolts (18), washers (19) and locknuts (20) that secure the brake cluster and back plate assembly to the front spindle plate (**Figure 6-1, Page 6-2**).

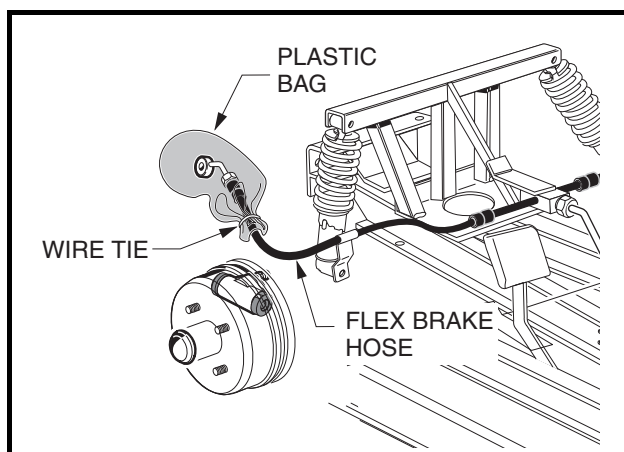


Figure 6-15 Front Brake Hose With Plastic Bag

### FRONT BRAKE CLUSTER ASSEMBLY INSTALLATION

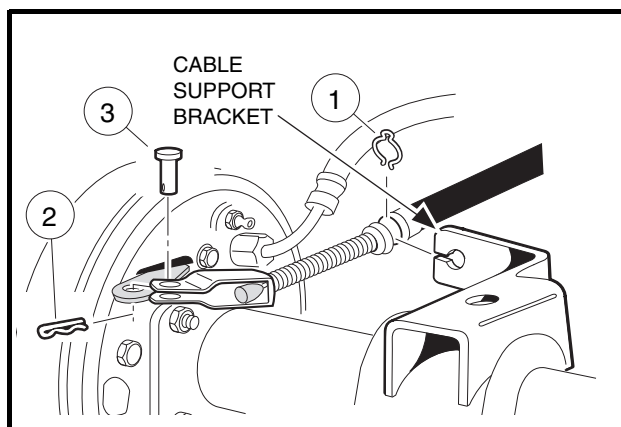
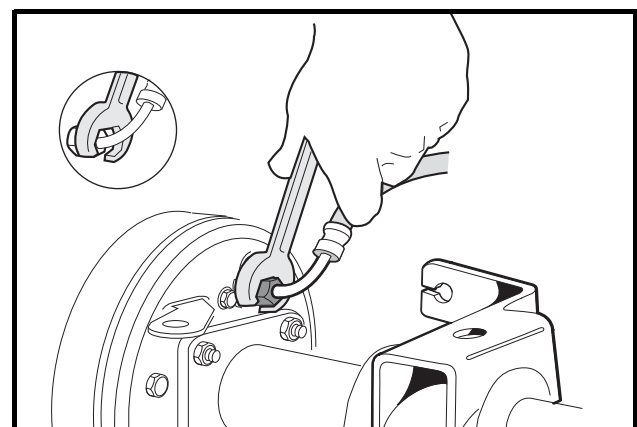
1. Install the back plate to the front spindle flange with four new Torx-head bolts (18), washers (19) and locknuts (20). Tighten all four bolts to 76 in-lb (8.6 N·m) (**Figure 6-1, Page 6-2**). **See following CAUTION.**

**Front Brake Cluster Assembly Installation, Continued:****⚠ CAUTION**

- Do not substitute hex-head bolts for Torx-head bolts. Hex-head bolts can interfere with the proper operation of the brake shoe adjusters.
2. Install a new banjo bolt (16) and new copper washers (17) to the wheel cylinder (7). Position the elbow of the brake hose toward the rear of the vehicle. Tighten the banjo bolt to 13 ft-lb (17.6 N·m) (**Figure 6-1, Page 6-2**).
  3. Install front wheel brake drum. **See Front Wheel Brake Drum Installation on page 6-14.**
  4. Bleed the front wheel brakes. **See Bleeding the Hydraulic Brake System on page 6-31.**
  5. Perform all of the brake system inspections. **See Brake System Inspection on page 6-1.**

**REAR BRAKE CLUSTER ASSEMBLY REMOVAL**

1. Remove rear brake drum. **See Rear Wheel Brake Drum Removal on page 6-8.**
2. Remove rear brake shoes. **See Rear Brake Shoe Removal on page 6-8.**
3. Remove park brake cable clip (1), hair spring cotter pin (2) and clevis pin (3) (**Figure 6-16, Page 6-18**).
4. Remove the cable from the cable support bracket.
5. Slide the cable so that the coiled spring wire, covering the cable wire, can be fed through the slot in the support bracket, and then remove.
6. Use a 3/8-inch flare nut wrench and remove the brake hose fitting from the rear wheel cylinder (**Figure 6-17, Page 6-18**).
7. Lift the hose above the brake cluster assembly and place a plastic bag over the hose fitting to keep dirt and debris from entering the hydraulic braking system (**Figure 6-18, Page 6-19**).
8. Use a Torx #T-40 driver and remove the four Torx-head bolts (16), washers (17), and locknuts (18) that secure the brake cluster back plate to the axle tube flange (**Figure 6-19, Page 6-21**).
9. Repeat steps 1 through 8 for the opposite rear wheel if necessary.

**Figure 6-16 Park Brake Cable****Figure 6-17 Rear Brake Hose Flare Nut**

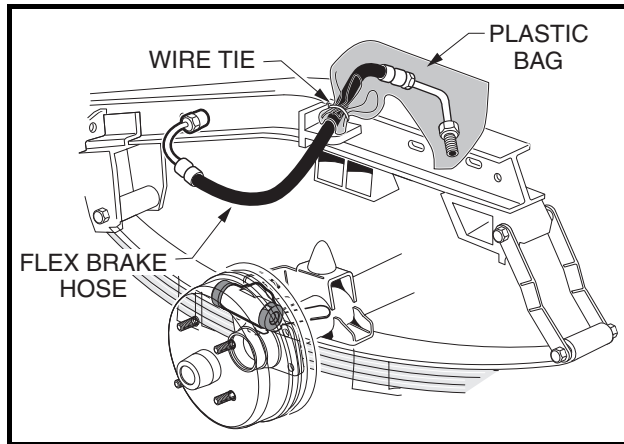


Figure 6-18 Rear Brake Hose With Plastic Bag

## REAR BRAKE CLUSTER ASSEMBLY INSTALLATION

1. Install the back plate to the axle tube flange with four new Torx-head bolts (16), washers (17) and lock-nuts (18). Tighten all four bolts to 76 in-lb (8.6 N·m) (Figure 6-19, Page 6-21). See following CAUTION.

### **▲ CAUTION**

- Do not substitute hex-head bolts for Torx-head bolts. Hex-head bolts can interfere with the proper operation of the brake shoe adjusters.

2. Connect the brake hose fitting to the wheel cylinder and tighten the flare nut fitting to 11 ft-lb (14.9 N·m).
3. Install the park brake cable into the cable support bracket by sliding the coiled spring wire through the slot in the bracket and feed the clevis end to the park brake lever (Figure 6-16, Page 6-18).
4. Install the park brake cable clip (1), clevis pin (3) and hair spring cotter pin (2).
5. Install rear brake shoes. See Rear Brake Shoe Installation on page 6-12.
6. Install rear wheel brake drum. See Rear Wheel Brake Drum Installation on page 6-16.
7. Repeat steps 1 through 6 for the opposite rear wheel if necessary.
8. Bleed the rear wheel brakes. See Bleeding the Hydraulic Brake System on page 6-31.
9. Perform all of the brake system inspections. See Brake System Inspection on page 6-1.

## WHEEL CYLINDER REPLACEMENT

See General Warning, Section 1, Page 1-1.

### **▲ WARNING**

- To perform this procedure, the hydraulic system must be opened. As a result, the brakes must be bled after the correct installation of the brake components. Failure to bleed the brakes could result in decreased braking performance due to air being trapped in the hydraulic system. Use only DOT 5 brake fluid. See Bleeding the Hydraulic Brake System on page 6-31.

## FRONT WHEEL CYLINDER REMOVAL

1. Remove front brake drum. See Front Wheel Brake Drum Removal on page 6-6.
2. Remove front brake shoes. See Front Brake Shoe Removal on page 6-8.

**Front Wheel Cylinder Removal, Continued:**

3. Remove the banjo bolt (16) and two copper washers (17) (**Figure 6-1, Page 6-2**).
4. Lift the hose above the brake cluster assembly and place a plastic bag over the hose fitting to keep dirt and debris from entering the hydraulic brake system (**Figure 6-15, Page 6-17**).
5. Remove two bolts (9) and lockwashers that secure the wheel cylinder (7) to the brake cluster back plate (1) (**Figure 6-1, Page 6-2**).
6. Repeat steps 1 through 5 for the remaining front wheel if necessary.

**FRONT WHEEL CYLINDER INSTALLATION**

1. Install wheel cylinder (7) with two new bolts (9) and lockwashers (**Figure 6-1, Page 6-2**). Tighten bolts to 120 in-lb (13 N·m).
2. Install a new banjo bolt (16) and new copper washers (17) to the wheel cylinder (7). Position the elbow of the brake hose toward the rear of the vehicle. Tighten bolt to 13 ft-lb (17.6 N·m).
3. Install front brake shoes. **See Front Brake Shoe Installation on page 6-12.**
4. Install front wheel brake drum. **See Front Wheel Brake Drum Installation on page 6-14.**
5. Repeat steps 1 through 4 for the remaining front wheel if necessary.
6. Bleed the front wheel brakes. **See Bleeding the Hydraulic Brake System on page 6-31.**
7. Perform all of the brake system inspections. **See Brake System Inspection on page 6-1.**

**REAR WHEEL CYLINDER REMOVAL**

1. Remove rear wheel brake drum. **See Rear Wheel Brake Drum Removal on page 6-8.**
2. Remove rear brake shoes. **See Rear Brake Shoe Removal on page 6-8.**
3. Use a 3/8-inch flare nut wrench and remove the brake hose fitting from the rear wheel cylinder (**Figure 6-17, Page 6-18**).
4. Lift the hose above the brake cluster assembly and place a plastic bag over the hose fitting to keep dirt and debris from entering the hydraulic brake system (**Figure 6-18, Page 6-19**).
5. Remove two bolts (9) and lockwashers that secure the wheel cylinder to the mounting plate (1), and remove the wheel cylinder (7) (**Figure 6-19, Page 6-21**).
6. Repeat steps 1 through 5 for the remaining rear wheel if necessary.

**REAR WHEEL CYLINDER INSTALLATION**

1. Install wheel cylinder (7) with two new bolts (9) and lockwashers and tighten the two bolts to 120 in-lb (13 N·m).
2. Connect the brake hose fitting to the wheel cylinder and tighten the flare nut fitting to 11 ft-lb (14.9 N·m) (**Figure 6-17, Page 6-18**).
3. Install rear brake shoes. **See Rear Brake Shoe Installation on page 6-12.**
4. Install rear wheel brake drum. **See Rear Wheel Brake Drum Installation on page 6-16.**
5. Repeat steps 1 through 4 for the remaining rear wheel if necessary.
6. Bleed the rear wheel brakes. **See Bleeding the Hydraulic Brake System on page 6-31.**
7. Perform all of the brake system inspections. **See Brake System Inspection on page 6-1.**



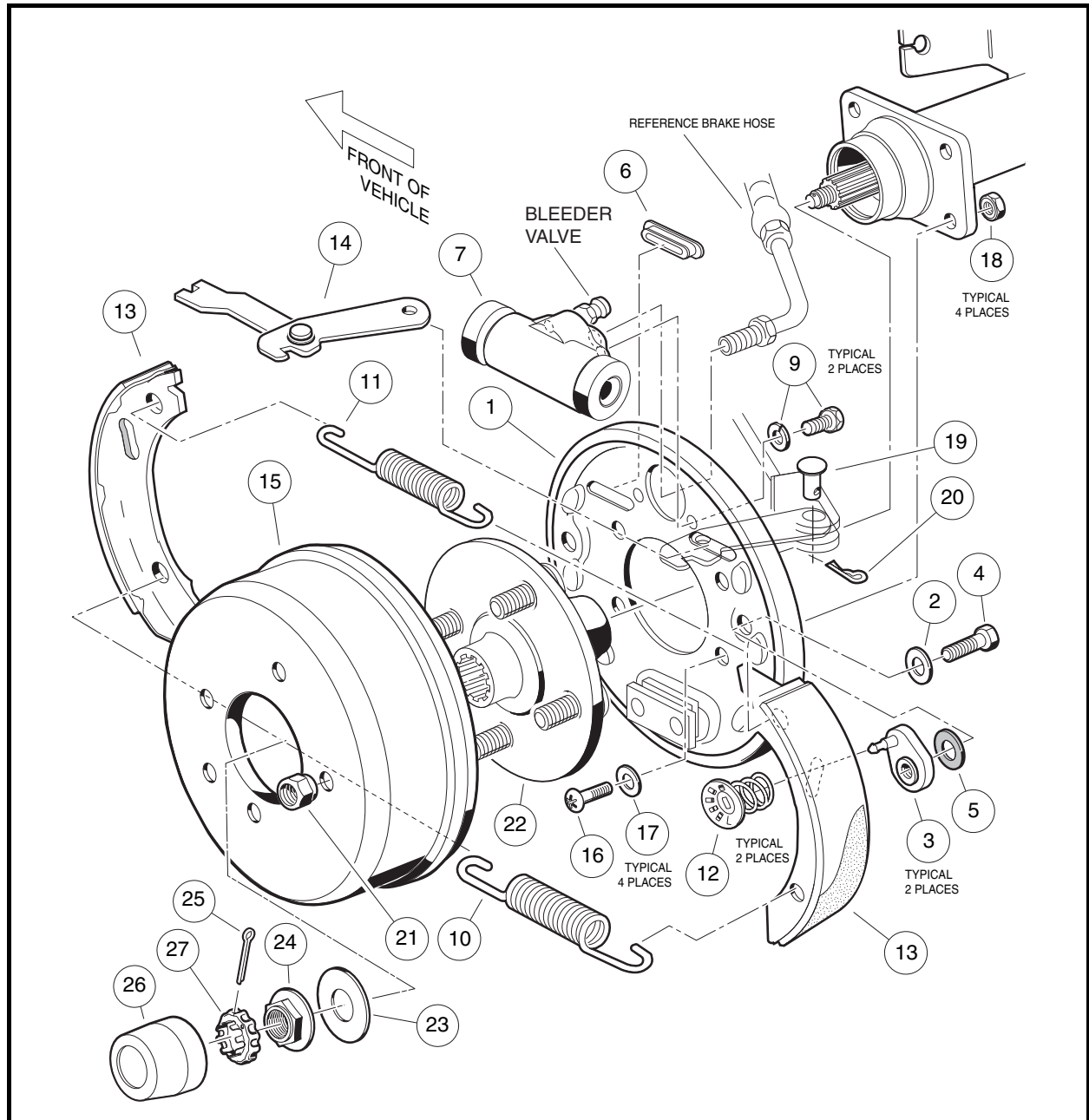


Figure 6-19 Rear Hydraulic Brake Cluster Assembly

## BRAKE SHOE ADJUSTER REPLACEMENT

See General Warning, Section 1, Page 1-1.

### **⚠ WARNING**

- If at any point in this procedure the hydraulic system is opened, the brakes must be bled after the correct installation of the brake components. Failure to bleed the brakes could result in decreased braking performance due to air being trapped in the hydraulic system. Use only DOT 5 brake fluid. See Bleeding the Hydraulic Brake System on page 6-31.

## FRONT BRAKE SHOE ADJUSTER REMOVAL

1. Remove front wheel brake drum. **See Front Wheel Brake Drum Removal on page 6-6.**
2. Remove front brake shoes. **See Front Brake Shoe Removal on page 6-8.**
3. Remove front brake cluster assembly. **See Front Brake Cluster Assembly Removal on page 6-17.**
4. Grip adjuster arm (3) with a pair of locking pliers and use a Torx #T-27 driver or 7/16-inch socket to remove the bolt (4), flat washer (2) and Bellville washer (5) from the brake cluster back plate (1) (**Figure 6-1, Page 6-2**). Remove remaining adjuster assembly and discard all adjuster components (3, 4, 2 and 5) for both assemblies.
5. Clean the back plate surfaces that contact the adjusters.
6. Repeat steps 1 through 5 for the remaining front wheel if necessary.

## FRONT BRAKE SHOE ADJUSTER INSTALLATION

**NOTE:** The adjusters must be replaced as pairs using new hardware.

1. Install bolt (4) through flat washer (2) and through the back plate (1) (**Figure 6-1, Page 6-2**).
2. Apply a light coat of grease to the Bellville washer (5) and install the washer onto the bolt (4) and against the inside surface of the back plate (1).
3. Carefully apply Loctite® 222 to the threaded portion of the bolt (4) and attach the adjuster arm (3). Position adjuster so that the brake mounting post is to the top of the back plate.
4. Grip adjuster arm (3) with a pair of locking pliers and tighten the bolt (4) to 115 in-lb (13 N·m).
5. Repeat steps 1 through 4 for the remaining adjuster.
6. Install front brake cluster assembly. **See Front Brake Cluster Assembly Installation on page 6-17.**
7. Install front brake shoes. **See Front Brake Shoe Installation on page 6-12.**
8. Install front wheel brake drum. **See Front Wheel Brake Drum Installation on page 6-14.**
9. Repeat steps 1 through 8 for the opposite front wheel if necessary.
10. Bleed the front brakes. **See Bleeding the Hydraulic Brake System on page 6-31.**
11. Perform all of the brake system inspections. **See Brake System Inspection on page 6-1.**

## REAR BRAKE SHOE ADJUSTER REMOVAL

1. Remove rear wheel brake drum. **See Rear Wheel Brake Drum Removal on page 6-8.**
2. Remove rear brake shoes. **See Rear Brake Shoe Removal on page 6-8.**
3. Remove rear brake cluster assembly. **See Rear Brake Cluster Assembly Removal on page 6-18.**
4. Grip adjuster arm (3) with a pair of locking pliers and use a Torx #T-27 driver, or 7/16-inch socket to remove the bolt (4), flat washer (2) and Bellville washer (5) from the brake cluster back plate (1) (**Figure 6-19, Page 6-21**). Remove remaining adjuster assembly and discard all adjuster components (3, 4, 2, and 5) for both assemblies.
5. Clean the back plate surfaces that contact the adjusters.
6. Repeat steps 1 through 5 for the remaining rear wheel if necessary.

## REAR BRAKE SHOE ADJUSTER INSTALLATION

**NOTE:** The adjusters must be replaced as pairs using new hardware.

1. Install bolt (4) and flat washer (2) to the back plate (1) (**Figure 6-19, Page 6-21**).

2. Apply a light coat of grease to the Bellville washer (5) and install the washer onto the bolt (4) and against the inside surface of the back plate (1).
3. Carefully apply Loctite 222 to the threaded portion of bolt (4) and attach the adjuster arm (3). Position adjuster so that the brake mounting post is to the top of the back plate.
4. Grip adjuster arm (3) with a pair of locking pliers and tighten the bolt (4) to 115 in-lb (13 N·m).
5. Repeat steps 1 through 4 for the remaining adjuster.
6. Install rear brake cluster assembly. **See Rear Brake Cluster Assembly Installation on page 6-19.**
7. Install rear brake shoes. **See Rear Brake Shoe Installation on page 6-12.**
8. Install rear brake drum. **See Rear Wheel Brake Drum Installation on page 6-16.**
9. Repeat steps 1 through 8 for the opposite rear wheel if necessary.
10. Bleed the rear brakes. **See Bleeding the Hydraulic Brake System on page 6-31.**
11. Perform all of the brake system inspections. **See Brake System Inspection on page 6-1.**

## HYDRAULIC LINE AND HOSE REPLACEMENT

---

See General Warning, Section 1, Page 1-1.

### **WARNING**

- To perform any of the following procedures, the hydraulic system must be opened. As a result, the brakes must be bled after the correct installation of the brake components. Failure to bleed the brakes could result in decreased braking performance due to air being trapped in the hydraulic system. Use only DOT 5 brake fluid. See Bleeding the Hydraulic Brake System on page 6-31.
- Prior to servicing hydraulic brakes, thoroughly clean the vehicle, paying particular attention to areas immediately surrounding hydraulic connections, to prevent dirt or debris from entering system.

### FRONT BRAKE LINE REMOVAL

1. Chock the rear wheels, release the park brake and lift the front of the vehicle with a chain hoist or floor jack. **See WARNING “Lift only one end...” in General Warning, Section 1, Page 1-2.**
2. Place jack stands under the outer front frame I-beams and lower onto stands. **See Figure 5-2, Section 5, Page 5-3.**
3. Drill the rivet (8) securing the brake line (4) to the vehicle frame (**Figure 6-20, Page 6-26**).
4. Place a pan below the vehicle to collect brake fluid and use a 7/16-inch flare nut wrench to remove front brake line (4) from the master cylinder.
5. Use a 3/8-inch flare nut wrench to remove brake line (4) from the T-manifold block (1).

### FRONT BRAKE LINE INSTALLATION

1. Connect brake line (4) to the master cylinder and finger-tighten (**Figure 6-20, Page 6-26**).
2. Connect brake line (4) to the T-manifold block (1) and finger-tighten.
3. Secure the brake line to the vehicle frame with the P-clamp (7), using a new 3/6 x 3/4-inch aluminum pop rivet (8), and two 3/16-inch rivet washers (14).

**Front Brake Line Installation, Continued:**

4. Tighten the flare nut (4) to the master cylinder to 11 ft-lb (14.9 N·m).
5. Tighten the flare nut (4) to the T-manifold block (1) to 11 ft-lb (14.9 N·m).
6. Fill the reservoir of the master cylinder and bleed the hydraulic system. **See Bleeding the Hydraulic Brake System on page 6-31.**
7. Perform all of the brake system inspections. **See Brake System Inspection on page 6-1.**

**FRONT BRAKE HOSE ASSEMBLY REMOVAL**

**NOTE:** If either of the two front brake hoses or the T-manifold block (1) are found to be damaged, the entire assembly must be replaced (**Figure 6-20, Page 6-26**).

1. Chock the rear wheels, release the park brake and lift the front of the vehicle with a chain hoist or floor jack. **See WARNING “Lift only one end...” in General Warning, Section 1, Page 1-2.**
2. Place jack stands under the outer front frame I-beams and lower onto stands. **See Figure 5-2, Section 5, Page 5-3.**
3. Place a pan below the vehicle to collect the brake fluid.
4. Remove the banjo bolt (5) and two copper washers (6) from the front wheel cylinder assemblies (**Figure 6-20, Page 6-26**). Discard the copper washers (6).
5. Remove the bolt (2), locknut (3), front hose bracket and weldment steering stop (34) from where the bottom of the shock connects to each of the front A-arms. **See Figure 7-28, Section 7, Page 7-17.**
6. Use a 3/8-inch flare nut wrench to remove the brake line (4) from the T-manifold block (1) (**Figure 6-20, Page 6-26**).
7. Remove the bolt (2), washer (13) and locknut (3) that secure the T-manifold block (1) to the shock tower.

**FRONT BRAKE HOSE ASSEMBLY INSTALLATION**

1. Install the 1/4-20 x 1-1/4-inch hex-head bolt (2) and nylon locknut (3), washer (13), T-manifold block (1) to frame bracket. Tighten to 76 in-lb (8.6 N·m) (**Figure 6-20, Page 6-26**).
2. Connect brake hoses with new copper washers (6) and banjo bolts (5). Position the elbow of each hose toward the rear of the vehicle. Tighten bolts to 13 ft-lb (17.6 N·m).
3. Attach front hose brackets, steering stop weldments (34), and lower shock absorber mounts using bolts (2), and locknuts (3). Align the steering stops (34) and brake hose brackets with the shock absorbers and tighten hardware to 20 ft-lb (27 N·m). **See Figure 7-28, Section 7, Page 7-17.**
4. Connect the flare fitting on the brake line (4) to the T-manifold block (1). Tighten to 11 ft-lb (14.9 N·m) (**Figure 6-20, Page 6-26**).
5. Fill the reservoir of the master cylinder and bleed the hydraulic system. **See Bleeding the Hydraulic Brake System on page 6-31.**
6. Perform all of the brake system inspections. **See Brake System Inspection on page 6-1.**

**REAR BRAKE LINE REMOVAL****1. Turf 272/Carryall 272/XRT 1200:**

- 1.1. Chock the front wheels, release the park brake, and lift the rear of the vehicle with a chain hoist or floor jack. **See WARNING “Lift only one end...” in General Warning, Section 1, Page 1-1.**
- 1.2. Place jack stands under the rear axle tubes and lower onto stands. **See Figure 5-2, Section 5, Page 5-3.**
- 1.3. Place a pan below the vehicle to collect the brake fluid.
- 1.4. Use a 3/8-inch flare nut wrench to remove brake line (10 or 11) from the master cylinder (**Figure 6-20, Page 6-26**).

- 1.5. Use a 3/8-inch flare nut wrench to remove the same brake line (10 or 11) from the rear brake hose at the I-beam of the vehicle frame.
- 1.6. Repeat steps 1.4 through 1.5 for the opposite rear brake line if necessary.

## 2. Carryall 472/XRT 1200 SE:

- 2.1. Chock the front wheels, release the park brake, and lift the rear of the vehicle with a chain hoist or floor jack. **See WARNING “Lift only one end... in General Warning, Section 1, Page 1-2.**
- 2.2. Place jack stands under the rear axle tubes and lower onto stands. **See Figure 5-2, Section 5, Page 5-3.**
- 2.3. Place a pan below the vehicle to collect the brake fluid.
- 2.4. Use a 3/8-inch flare nut wrench to remove brake line (15) from the master cylinder (**Figure 6-21, Page 6-27**).
- 2.5. Use a 3/8-inch flare nut wrench and remove rear brake line (15) from the brake tee (17).
- 2.6. Remove rear brake line (10 or 11) from the brake tee.
- 2.7. Remove rear brake line (10 or 11) from the brake hose at the I-beam of the vehicle frame.
- 2.8. Repeat steps 2.6 and 2.7 for the opposite rear brake line if necessary.
- 2.9. Remove the bolt (18) from the brake tee (17) and remove the tee from the vehicle frame.

## REAR BRAKE LINE INSTALLATION

### 1. Turf 272/Carryall 272/XRT 1200:

- 1.1. Install brake line (10 or 11) to rear brake hose at the I-beam of the vehicle frame and tighten to 11 ft-lb (14.9 N·m) (**Figure 6-20, Page 6-26**).
- 1.2. Install the opposite end of the brake line to the master cylinder and tighten the flare nut fitting to 11 ft-lb (14.9 N·m) (**Figure 6-20, Page 6-26**).
- 1.3. Repeat steps 1.1 through 1.2 for the opposite rear brake line if necessary.
- 1.4. Fill the reservoir of the master cylinder and bleed the hydraulic system. **See Bleeding the Hydraulic Brake System on page 6-31.**
- 1.5. Perform all of the brake system inspections. **See Brake System Inspection on page 6-1.**

### 2. Carryall 472/XRT 1200 SE:

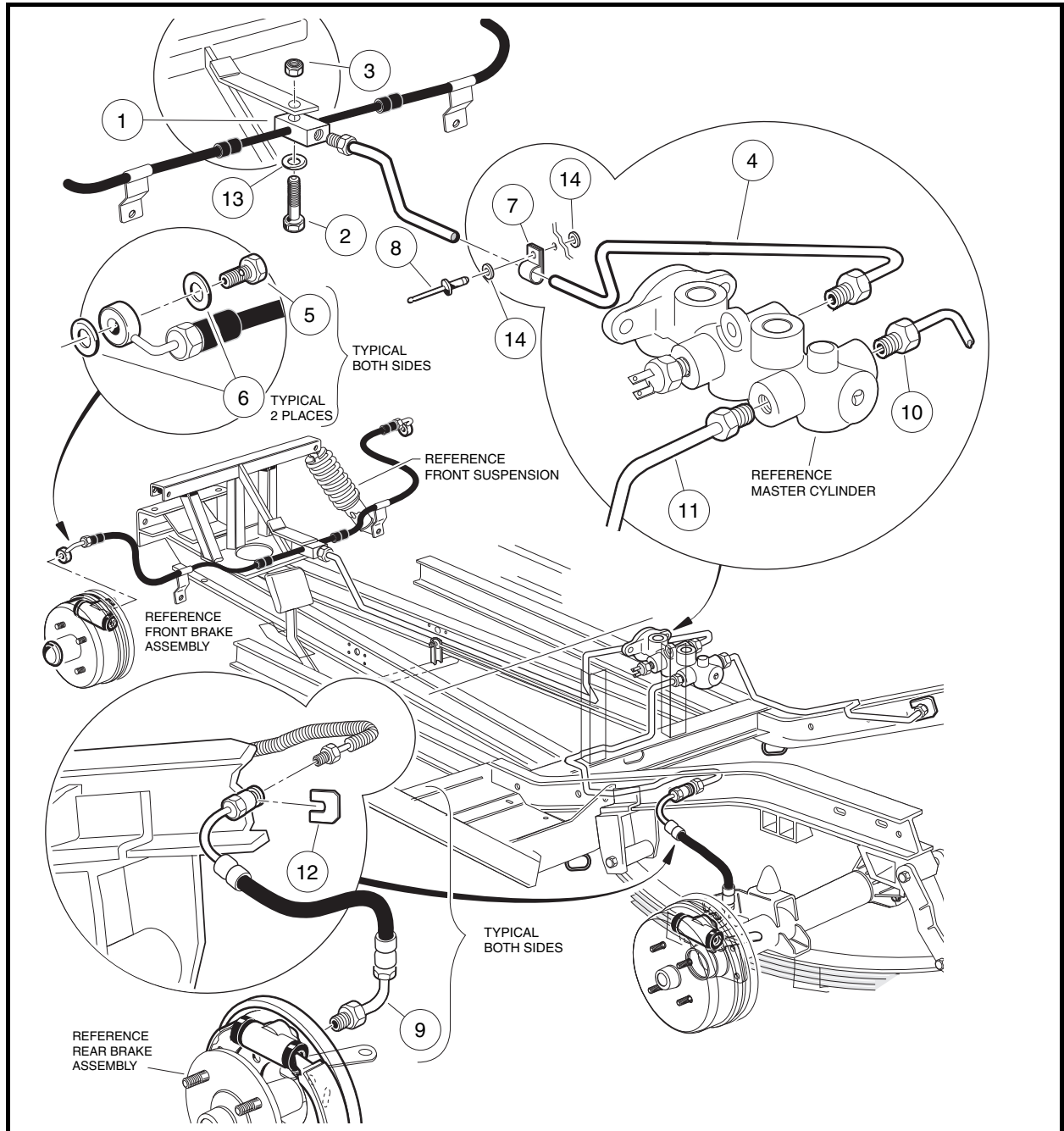
- 2.1. Install brake tee (17) to vehicle frame plate using hex-head 1/4-20 x 3/4-inch bolt (18) and tighten to 65 in-lb (7.345 N·m) (**Figure 6-21, Page 6-27**).
- 2.2. Install brake line (10 or 11) to rear brake hose at the I-beam of the vehicle frame and tighten to 11 ft-lb (14.9 N·m).
- 2.3. Install the opposite end of the brake line to the brake tee (17) and tighten to 11 ft-lb (14.9 N·m).
- 2.4. Repeat steps 2.2 and 2.3 for the opposite rear brake line if necessary.
- 2.5. Install rear brake line (15) to brake tee (17) and tighten to 11 ft-lb (14.9 N·m).
- 2.6. Install opposite end of the brake line (15) to the master cylinder and tighten to 11 ft-lb (14.9 N·m).
- 2.7. Fill the reservoir of the master cylinder and bleed the hydraulic system. **See Bleeding the Hydraulic Brake System on page 6-31.**
- 2.8. Perform all of the brake system inspections. **See Brake System Inspection on page 6-1.**

## REAR BRAKE HOSE REMOVAL

1. Chock the front wheels, release the park brake, and lift the rear of the vehicle with a chain hoist or floor jack. **See WARNING “Lift only one end...” in General Warning, Section 1, Page 1-2.**
2. Place jack stands under the rear axle tubes and lower onto stands. **See Figure 5-2, Section 5, Page 5-3.**
3. Place a pan below the vehicle to collect the brake fluid.

**Rear Brake Hose Removal, Continued:**

4. Use a 3/8-inch flare nut wrench to remove the brake hose from the wheel cylinder (Figure 6-17, Page 6-18).
5. Use a 3/8-inch flare nut wrench to remove the rear brake line (10 or 11) from the rear brake hose at the I-beam of the vehicle frame (Figure 6-20, Page 6-26 or Figure 6-21, Page 6-27).
6. Remove the horseshoe clip (12) that secures the rear brake hose (9) to the I-beam frame and remove brake hose (9) through the D-shaped hole in the vehicle I-beam.
7. Repeat steps 4 through 6 for the opposite rear brake hose if necessary.



**Figure 6-20 272/1200 Four-Wheel Hydraulic Brake System**

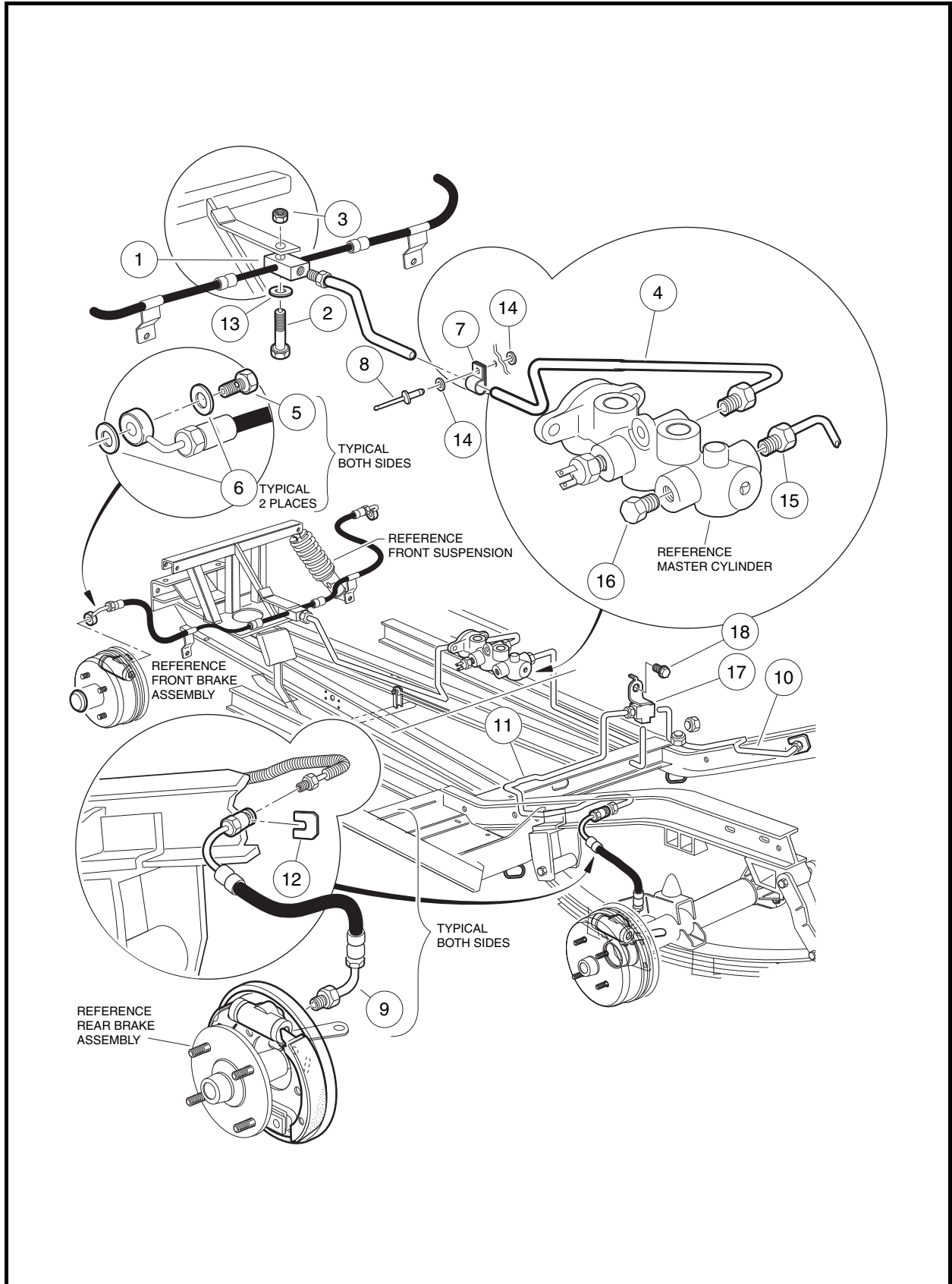


Figure 6-21 Carryall 472/XRT 1200 SE Four-Wheel Hydraulic Brake System

## REAR BRAKE HOSE INSTALLATION

1. Install brake hose (9) through the oval-shaped hole in the vehicle I-beam, and install the horseshoe clip (12) that secures the brake hose to the I-beam frame (**Figure 6-20, Page 6-26 or Figure 6-21, Page 6-27**).
2. Attach the flare nut fitting on the brake hose (9) to the wheel cylinder (**Figure 6-17, Page 6-18**) and tighten to 11 ft-lb (14.9 N·m).
3. Install the rear brake line (10 or 11) to the rear hose (9) at the I-beam of the vehicle frame (**Figure 6-20, Page 6-26 or Figure 6-21, Page 6-27**). Tighten to 11 ft-lb (14.9 N·m).
4. Repeat steps 1 through 3 for the opposite rear brake hose if necessary.
5. Fill the reservoir of the master cylinder and bleed the hydraulic system. **See Bleeding the Hydraulic Brake System on page 6-31.**
6. Perform all of the brake system inspections. **See Brake System Inspection on page 6-1.**

## MASTER CYLINDER AND BELL CRANK REPLACEMENT

**See General Warning, Section 1, Page 1-1.**

### BELL CRANK REMOVAL

1. Chock the wheels and release the park brake and access the master cylinder bell crank.
2. Remove brake rod clevis pin (6), bow tie locking pin (8) and clevis (16) from the bell crank (13) (**Figure 6-22, Page 6-30**).
3. Remove the spring (18) from the bell crank (13) and master cylinder mounting bracket (19).
4. Remove push rod (3), clevis pin (6) and bow tie locking pin (8).
5. Remove bell crank clevis pin (9) and bow tie locking pin (11) from the master cylinder mounting bracket (19) and remove bell crank (13) and centering spacer (12).

### BELL CRANK INSTALLATION

1. Install bell crank clevis pin (9) through the master cylinder bracket (19), bell crank (13), centering spacer (12) and attach bow tie locking pin (11) (**Figure 6-22, Page 6-30**).
2. Install push rod clevis pin (6) through bell crank (13) and push rod (3) and attach bow tie locking pin (8).
3. Install brake rod clevis pin (6) through clevis (16) and bell crank (13) and attach bow tie locking pin (8).
4. Install spring (18).
5. Adjust the brake pedal as instructed. **See Brake Pedal Adjustment, Section 5, Page 5-3.**
6. Perform all of the brake system inspections. **See Brake System Inspection on page 6-1.**

### MASTER CYLINDER REMOVAL

#### **WARNING**

- **To perform this procedure, the hydraulic system must be opened. As a result, the brakes must be bled after the correct installation of the brake components. Failure to bleed the brakes could result in decreased braking performance due to air being trapped in the hydraulic system. Use only DOT 5 brake fluid. See Bleeding the Hydraulic Brake System on page 6-31.**



1. Chock the wheels and release the park brake and access the master cylinder.
2. Place a pan below the vehicle to collect the brake fluid.
3. Remove the two wires from the master cylinder pressure switch (4) (**Figure 6-22, Page 6-30**).
4. Use a 7/16-inch flare nut wrench to remove the brake line (4) from the master cylinder (**Figure 6-20, Page 6-26 or Figure 6-21, Page 6-27**).
5. **Turf 272/Carryall 272/XRT 1200:**
  - 5.1. Use a 3/8-inch flare nut wrench to remove the brake lines (10 and 11) from the master cylinder (**Figure 6-20, Page 6-26**).
6. **Carryall 472/XRT 1200 SE:**
  - 6.1. Use a 3/8-inch flare nut wrench to remove the brake line (15) from the master cylinder (**Figure 6-21, Page 6-27**).
7. Cover the flare nut fittings on the brake lines with plastic bags and wire ties to keep any dirt or debris from entering the hydraulic brake system.
8. Remove the two bolts (7) and nylon locknuts (8) that secure the master cylinder (1) (**Figure 6-22, Page 6-30**).
9. Remove master cylinder (1) from mounting bracket (19), push rod (3) and rubber boot (2).

## MASTER CYLINDER INSTALLATION

1. Install master cylinder (1) into mounting bracket (19) and insert push rod (3), then seat boot (2) (**Figure 6-22, Page 6-30**).
2. Install the two bolts (7) and nylon locknuts (8) that secure the master cylinder (1) to the master cylinder mounting bracket (19) and tighten to 14 ft-lb (19 N·m).
3. Attach brake line (4) to master cylinder and tighten flare nut fitting to 11 ft-lb (14.9 N·m) (**Figure 6-20, Page 6-26**).
4. **Turf 272/Carryall 272/XRT 1200:**
  - 4.1. Attach brake lines (10 and 11) to master cylinder and tighten flare nut fittings to 11 ft-lb (14.9 N·m) (**Figure 6-20, Page 6-26**).
5. **Carryall 472/XRT 1200 SE:**
  - 5.1. Attach brake line (15) to master cylinder and tighten flare nut fittings to 11 ft-lb (14.9 N·m) (**Figure 6-21, Page 6-27**).
6. Attach the two wires to the master cylinder pressure switch (4) (no particular orientation).
7. Adjust the brake pedal as instructed in Section 5. **See Brake Pedal Adjustment, Section 5, Page 5-3.**
8. Fill the reservoir of the master cylinder and bleed the entire hydraulic brake system. **See Bleeding the Hydraulic Brake System on page 6-31.**
9. Perform all of the brake system inspections. **See Brake System Inspection on page 6-1.**

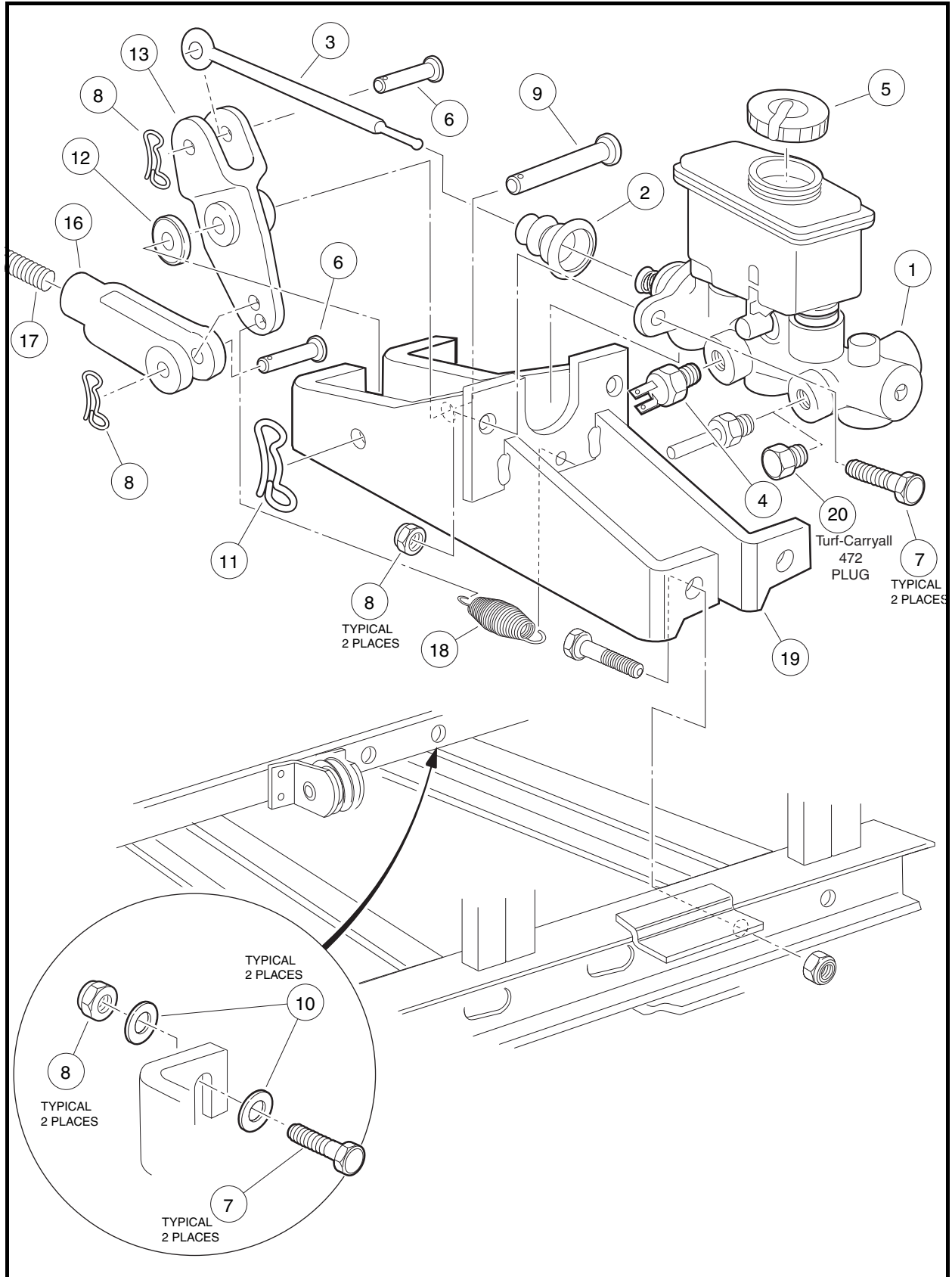


Figure 6-22 Master Cylinder

## BLEEDING THE HYDRAULIC BRAKE SYSTEM

### See General Warning, Section 1, Page 1-1.

The hydraulic system must be free of air. Air enters the hydraulic system whenever the system is opened and will result in a “spongy” brake pedal.

The master cylinder controls two separate hydraulic sub-systems. The front two wheels are connected to the smaller, front portion of the brake fluid reservoir, and the rear wheels to the larger portion. One or both sub-systems may require bleeding, depending on where the hydraulic system was opened. To bleed both, use the following procedure, front brakes first.

1. Check the brake pedal and master cylinder push rod for proper adjustment before proceeding. **See Brake Pedal Adjustment, Section 5, Page 5-3.**
2. Chock front or rear wheels, release the park brake, and lift the vehicle with a chain hoist or floor jack. **See WARNING “Lift only one end...” in See General Warning, Section 1, Page 1-1.**
3. Place jack stands under the outer front frame, or under the rear axle tubes and lower onto stands. **See Figure 5-2, Section 5, Page 5-3.**
4. Remove the cap from the master cylinder reservoir and fill the reservoir with DOT 5 brake fluid.
5. Remove each wheel and gently adjust the clearance between the brake shoes and brake drum by turning each of the two adjusters on the brake cluster (**Figure 6-14, Page 6-16**). Use a torque wrench and a Torx #T-27 driver or hydraulic brake adjuster (CC P/N 102169401). **See following CAUTION.**

### **▲ CAUTION**

- **Do not apply more than 65 in-lb (7.3 N-m) of torque to any of the adjuster bolts. Overtightening the adjuster bolts could result in damage to the brake cluster components or the separation of the bolt (4) from the adjuster (3) (Figure 6-1, Page 6-2 or Figure 6-19, Page 6-21).**
6. Place, but do not tighten, the cap onto the master cylinder reservoir.
  7. Connect vacuum type brake bleeder (CC P/N S0010702).
    - **Front brakes only:** Connect the two hose fittings from a vacuum type brake bleeder to the brake bleeder valves on the back of each of the front wheel brake cluster assemblies (**Figure 6-23, Page 6-32**). Proceed to step 8.
    - **Rear brakes only:** Connect the two hose fittings from a vacuum type brake bleeder to the brake bleeder valves on the back of each of the rear wheel brake cluster assemblies. Proceed to step 8.
  8. Connect an air hose to the vacuum brake bleeder. The air pressure must be regulated at 12 to 15 psi (0.827 to 1.034 Bars).
  9. Press the handle on the brake bleeder to start the vacuum.
  10. With the vacuum running, open both of the brake bleeder valves 1/4 turn. **See Figure 6-1, Page 6-2 or Figure 6-19, Page 6-21.**
  11. Monitor the fluid as it flows through the tubes of the vacuum bleeder tool. Continue to run the vacuum until there are almost no air bubbles in the lines. **See following NOTE.**

**NOTE:** Do not allow the brake fluid in the master cylinder reservoir to drop below the “min” level mark at any time during the brake bleeding procedure (**Figure 6-24, Page 6-33**).
  12. With the vacuum still running, tighten the two brake bleeder valves.
  13. Allow the handle on the brake bleeder tool to open, turning the vacuum system off.
  14. Fill the master cylinder reservoir to the “MAX” level with DOT 5 brake fluid (**Figure 6-24, Page 6-33**).
  15. Tighten the cap on the master cylinder reservoir.
  16. Properly dispose of the brake fluid in the vacuum type brake bleeder tool.
  17. Perform all of the brake system inspections. **See Brake System Inspection on page 6-1.**

## PURGING THE HYDRAULIC SYSTEM

In some cases it may be necessary to completely drain the front, rear or entire hydraulic brake system of brake fluid. To completely purge the hydraulic system, perform the following procedure.

1. Perform steps 2 through 10 of the brake bleeding procedure on the two front wheels. **See Bleeding the Hydraulic Brake System on page 6-31.**
2. Allow 1 quart. (0.9464 l) of the brake fluid to be pulled into the vacuum type brake bleeder tool.
3. With the vacuum still running, tighten the two brake bleeder valves.
4. Allow the handle on the brake bleeder tool to open, turning the vacuum system off.
5. Repeat steps 1 through 4 for the two rear wheels.

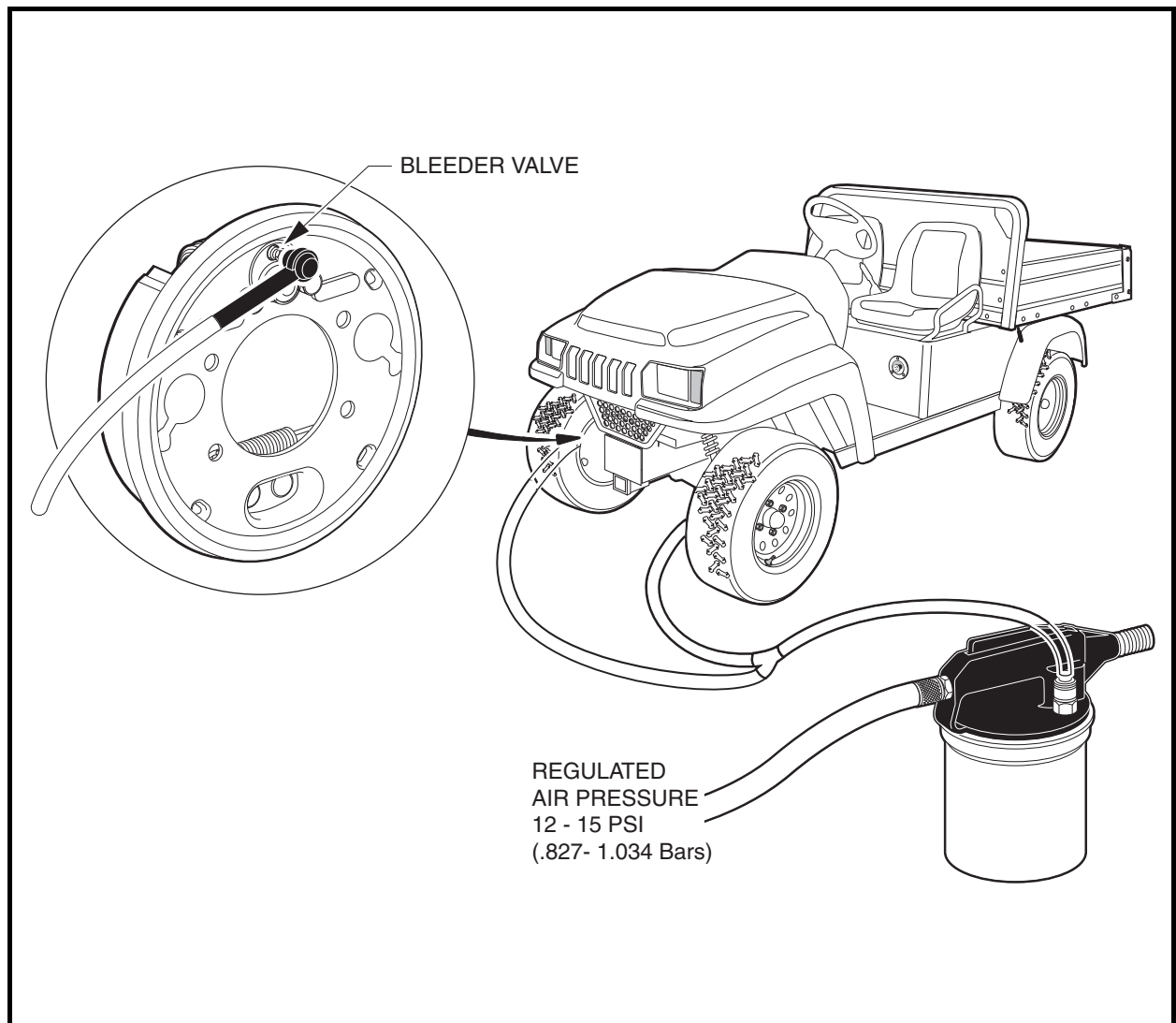


Figure 6-23 Front and Rear Brake Bleeding

## FILLING THE HYDRAULIC SYSTEM

After purging the brake system and making any necessary repairs, bleed the brakes, adding DOT 5 brake fluid until the system is full and virtually no air bubbles are present in the brake bleeder vacuum tubes. **See Bleeding the Hydraulic Brake System on page 6-31.**

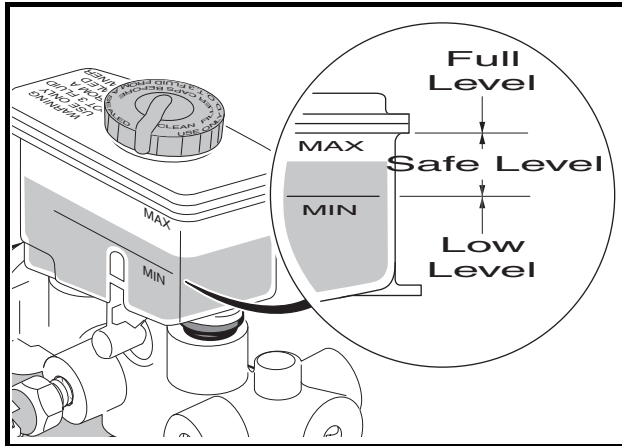


Figure 6-24 Master Cylinder Reservoir

## PARK BRAKE SYSTEM

See General Warning, Section 1, Page 1-1.

### PARK BRAKE CABLE REMOVAL

#### Equalizer Cable Removal

1. Chock the wheels and release the park brake.
2. Remove the two screws (3) that secure the park brake boot (2) to the seat support (**Figure 6-27, Page 6-37**).
3. Slide the boot (2) off of the park brake handle (1).
4. Remove the boot shield (27) from the park brake handle.
5. Remove the equalizer spring (21) from the equalizer cable (9).
6. Remove the equalizer jam nut (11) and conical nut (23) from the cable end (9).
7. Remove the end of the park brake cable from handle (1) by pushing the equalizer cable in an upward direction and pulling the cable end toward the passenger side of the vehicle.
8. Remove the equalizer cable from the vehicle.

#### Park Brake Pulley Removal

1. Remove the park brake equalizer cable. **See Park Brake Cable Removal on page 6-33.**
2. Remove the four #10-24 x 3/4-inch socket-head screws (14), locknuts (18) and washers (17) from frame and remove the assembly (**Figure 6-27, Page 6-37**).

#### Wheel Brake Cable Removal

1. Loosen the equalizer jam nut (11) and the conical nut (23) to provide slack in the wheel brake cables (**Figure 6-27, Page 6-37**).
2. Pull a wheel brake cable to the side and remove the cable end from the keyhole opening in the park brake equalizer (**Figure 6-25, Page 6-34 and Figure 6-26, Page 6-34**).
3. Remove the cable clip (23) from a wheel brake cable (22) at the vehicle frame (25) (**Figure 6-27, Page 6-37**).
4. Remove a park brake cable clip (12), hair spring cotter pin (20) and clevis pin (19).
5. Remove the cable from a cable support bracket (16 or 24).
6. Slide the cable through the frame hanger (15) and remove the cable from the vehicle.
7. Remove the remaining wheel brake cable in the same manner.

## PARK BRAKE CABLE INSTALLATION

### Park Brake Pulley Installation

1. Align the equalizer cable pulley assembly (13) with the mounting holes in the frame (**Figure 6-27, Page 6-37**).
2. Install the four 10-24 x 3/4-inch socket-head screws (14), flat washers (17) and locknuts (18) and tighten to 54 in-lb (6.1 N·m).

**NOTE:** Use new 10-24 locknuts for this assembly procedure.

3. Install equalizer cable. See **Park Brake Cable Installation on page 6-34**.

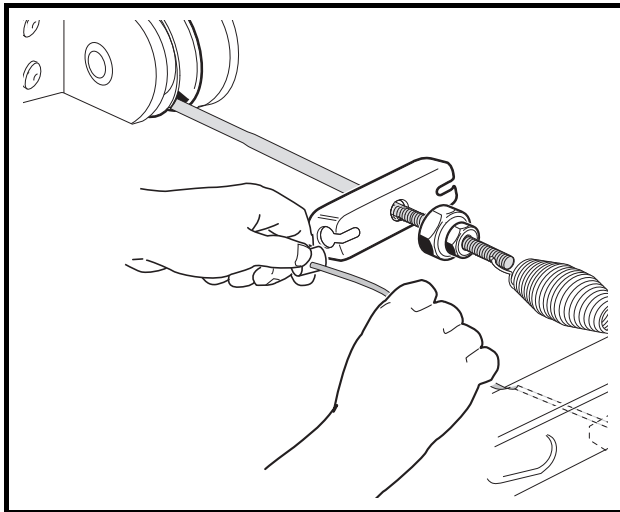


Figure 6-25 Position Wheel Brake Cable

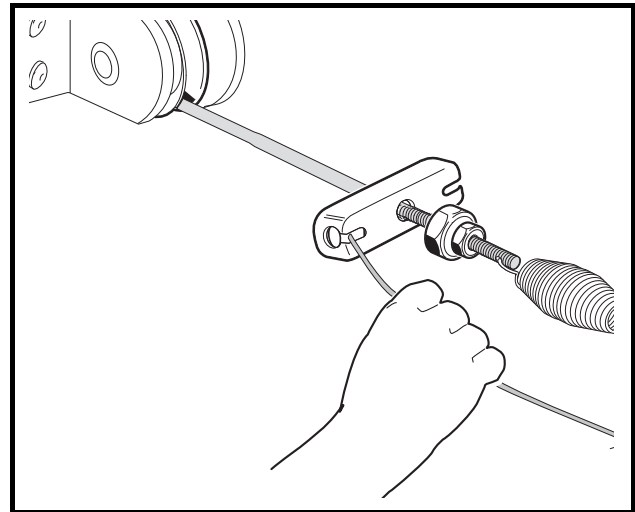


Figure 6-26 Wheel Brake Cable Attachment

### Equalizer Cable Installation

1. Thread the equalizer cable (9) up between the pulley and frame, through the top seat support slot and hook the end of the cable into the handle (1) clevis slot from the passenger side (**Figure 6-27, Page 6-37**).
2. Assemble the equalizer bracket (10) onto the threaded end of the equalizer cable (9).
3. Attach the conical nut (23) and equalizer jam nut (11) to the threaded end of the equalizer cable.
4. Attach the equalizer spring (21) from the equalizer cable to the frame.
5. Slide the boot shield (27) around the park brake handle.
6. Slide the boot (2) over the handle and down around the boot shield and onto the seat support.
7. Attach the boot (2) using two 5/16-18 phillips head screws (3).
8. Adjust the park brake. See **Park Brake Adjustment on page 6-35**.

### Wheel Brake Cable Installation

1. Slide a cable (22) through the frame hanger (15) (**Figure 6-27, Page 6-37**).
2. Attach the cable clevis and wheel brake lever using the clevis pin (19) and hair spring cotter pin (20).
3. Attach the cable (22) to the cable support bracket (16 or 24), using a wire clip (12).
4. Attach the opposite end of cable (22) through a frame bracket notch (25) and secure with a wire clip (23).

5. Pull the end of the brake cable (8) up and into a keyhole opening in the park brake equalizer bracket (10).
6. Adjust the park brake. **See Park Brake Adjustment on page 6-35.**
7. Install the remaining wheel brake cable if necessary.

## PARK BRAKE HANDLE REMOVAL

1. Remove the park brake equalizer cable. **See Equalizer Cable Removal on page 6-33.**
2. Remove the two bolts (4), four washers (5) and two locknuts (6) from the park brake handle (**Figure 6-27, Page 6-37**).
3. Remove the park brake handle (1) from the seat support.

## PARK BRAKE HANDLE INSTALLATION

1. Attach the handle (1) to the seat support using two 3/8-16 x 1-1/4-inch hex-head bolts (4), 3/8 flat washers (5) and 3/8-16 locknuts (6) (**Figure 6-27, Page 6-37**). Tighten the nuts to 23 ft-lb (31.4 N·m).

**NOTE:** Use new 3/8-16 locknuts for this assembly procedure.

2. Install the park brake cable. **See Equalizer Cable Installation on page 6-34.**
3. Adjust the park brake. **See Park Brake Adjustment on page 6-35.**
4. Perform all of the brake system inspections. **See Brake System Inspection on page 6-1.**

## PARK BRAKE ADJUSTMENT

### **⚠ CAUTION**

- **Perform the following procedure only on level surface. To avoid injury or property damage, ensure that the path of the vehicle is clear before pushing vehicle.**

1. Ensure that the brake pedal is adjusted correctly. **See Brake Pedal Adjustment, Section 5, Page 5-3.**
2. Chock the wheels, release the park brake and place the Forward/Reverse handle in the NEUTRAL position.
3. Loosen the equalizer jam nut (11) and the conical nut (23) to provide slack in the wheel brake cables (**Figure 6-27, Page 6-37**).
4. Use a torque wrench and Torx #T-27 driver, or hydraulic brake adjuster (CC P/N 102169401), to gently rotate the adjuster bolts to increase or decrease the clearance between the brake shoe lining and the brake drum (**Figure 6-14, Page 6-16**). **See following CAUTION.**

### **⚠ CAUTION**

- **Do not apply more than 65 in-lb (7.3 N·m) of torque to any of the adjuster bolts. Overtightening of the adjuster bolts could result in damage to the brake cluster components or the separation of the bolt (4) from the adjuster (3) (Figure 6-1, Page 6-2 or Figure 6-19, Page 6-21).**

**Park Brake Adjustment, Continued:**

5. With the park brake released (down), tighten the conical nut (23) until significant resistance is observed in the equalizer cable in order to fully lock the brakes (**Figure 6-27, Page 6-37**).
6. With the vehicle on flat ground and the Forward/Reverse handle in the NEUTRAL position, push the vehicle by hand. If the wheels move when the vehicle is pushed, continue tightening the conical nut until the vehicle can no longer be pushed.
7. Loosen the conical nut two full revolutions.
8. Tighten the equalizer jam nut (11) against the conical nut (23), using the double-wrench method, to 55 in-lb (6.3 N·m).
9. The park brake should now be adjusted so that the vehicle will not roll when pushed with the park brake latched in the fourth notch (four clicks from the bottom of its travel).
10. Perform all of the brake system inspections to ensure that both the hydraulic brake system and the park brake system are adjusted and operating correctly before placing the vehicle into service. **See Brake System Inspection on page 6-1.**



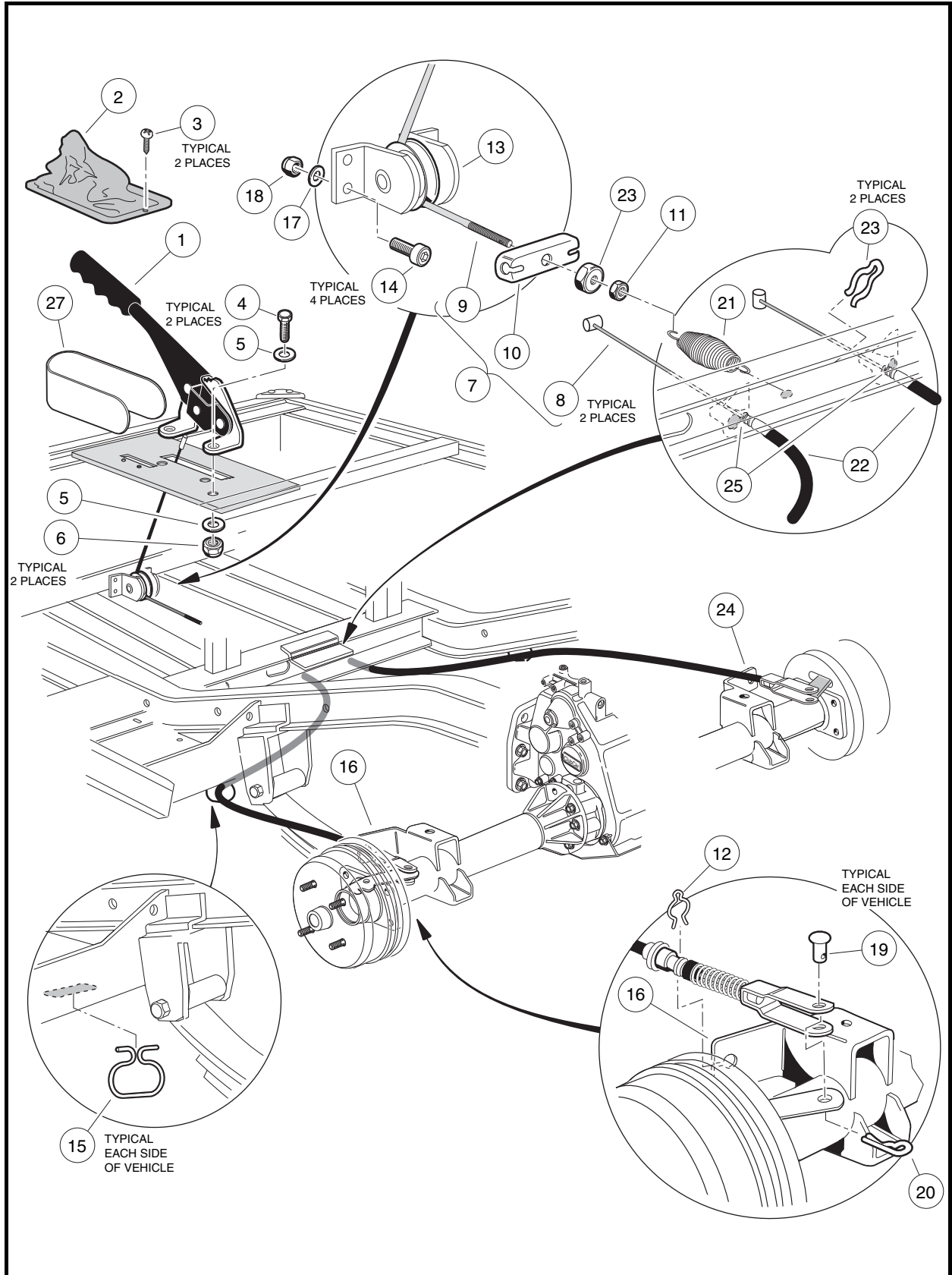


Figure 6-27 Park Brake System



# SECTION 7 – STEERING AND FRONT SUSPENSION

## **▲ DANGER**

- See General Warning, Section 1, Page 1-1.

## **▲ WARNING**

- See General Warning, Section 1, Page 1-1.

## STEERING WHEEL

See General Warning, Section 1, Page 1-1.

### STEERING WHEEL REMOVAL

1. Make sure the key switch is OFF and the Forward/Reverse handle is in the NEUTRAL position. Chock the wheels.
2. Disconnect battery and spark plug wire(s). **See Disconnecting The Battery on page 1-3.**
3. Remove the two mounting screws (24) and plate (19) (**Figure 7-3, Page 7-2**).
4. Match mark the steering wheel (25) and steering column shaft (11) for installment positioning.
5. Loosen the steering wheel nut (18) and back it off approximately 1/4-inch (6 mm). Do not remove the nut.
6. Use the steering wheel puller (CC P/N 102061201) to remove steering wheel.
  - 6.1. Place the puller anvil (4) through the top opening of the steering wheel (**Figure 7-1, Page 7-1**).
  - 6.2. Insert the anvil feet through the two slots in the base plate (marked "B") (5).
  - 6.3. Rotate the anvil screw (6) clockwise until the base plate contacts the bottom of the steering wheel at the steering column (**Figure 7-2, Page 7-1**).
  - 6.4. Use a 1/2-inch drive air impact wrench and tighten the anvil screw (6) until the steering wheel releases from the steering shaft.
  - 6.5. Remove the steering wheel puller.
  - 6.6. Remove the steering wheel nut (18) and the steering wheel from the steering column (13).

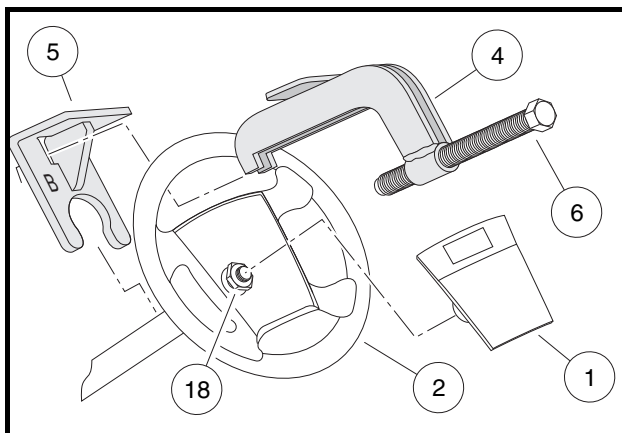


Figure 7-1 Steering Wheel Puller

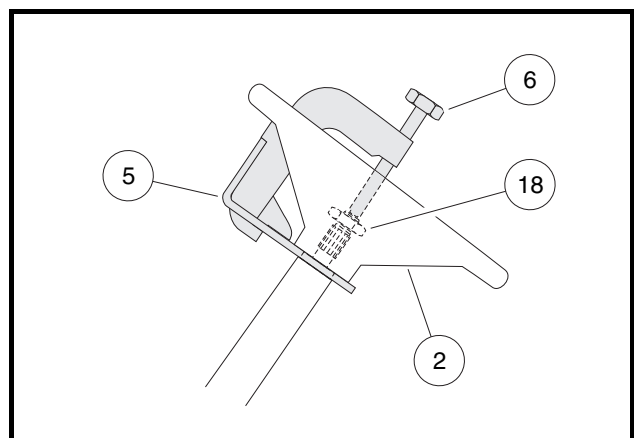


Figure 7-2 Steering Wheel Puller

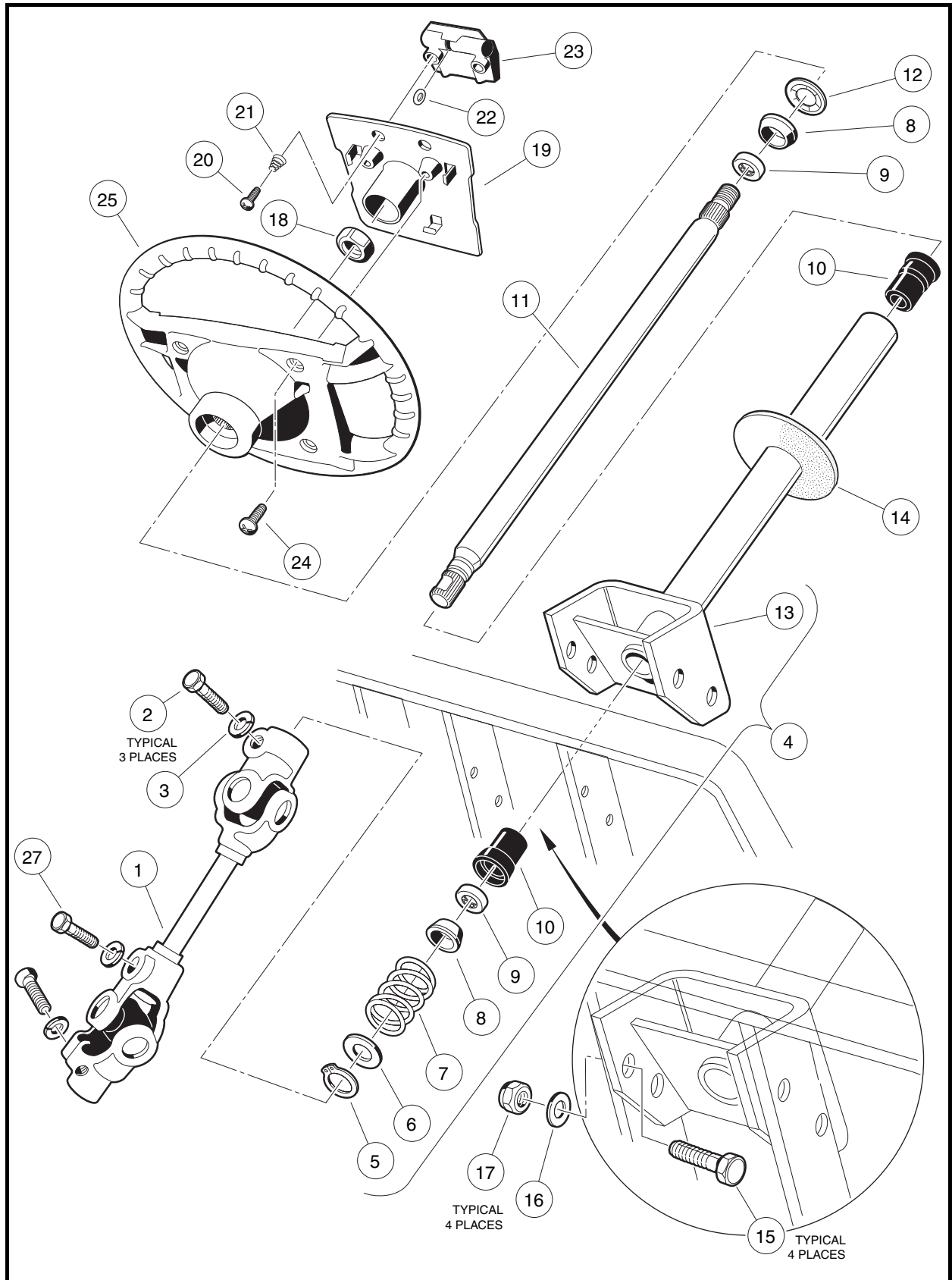


Figure 7-3 Steering Column

## STEERING WHEEL INSTALLATION

**NOTE:** To minimize corrosion, apply a small amount of oil or anti-seize compound to steering shaft splines and taper before installing the steering wheel.

1. Install the steering wheel (25) on the splines of the steering shaft (11) (**Figure 7-3, Page 7-2**). Align the match marks placed on the wheel and steering column shaft in step 4, Steering Wheel Removal on page 7-1.
2. Install the steering wheel nut (18) and tighten to 13 ft-lb (17.6 N·m).
3. Install the steering wheel plate (19) and mounting screws (24) and tighten screws to 16 in-lb (1.8 N·m).
4. Connect battery and spark plug wire(s). **See Connecting The Battery on page 1-3.**

## STEERING COLUMN

**See General Warning, Section 1, Page 1-1.**

### STEERING COLUMN REMOVAL

1. Make sure the key switch is OFF and the Forward/Reverse handle is in the NEUTRAL position. Chock the wheels.
2. Disconnect battery and spark plug wire(s). **See Disconnecting The Battery on page 1-3.**
3. Remove the steering wheel. **See Steering Wheel Removal on page 7-1.**
4. Remove dashboard. **See Dashboard Removal, Section 4, Page 4-3.**
5. Remove the front body. **See Front Body Removal, Section 4, Page 4-5.**
6. Remove the upper bolt (2) and lockwasher (3) from the steering universal joint (1) (**Figure 7-3, Page 7-2**).
7. Remove the nuts (17), bolts (15) and washers (16) from the steering column mount (13) (**Figure 7-3, Page 7-2**).
8. Disconnect the steering universal joint (1) from the steering column shaft and remove the steering column from the vehicle (**Figure 7-3, Page 7-2**).

### STEERING COLUMN DISASSEMBLY

1. While supporting steering column (13) on a workbench, remove snap ring (5) from shaft (**Figure 7-3, Page 7-2**).

**NOTE:** Do not allow the steering shaft to slide out of the steering tube when removing the snap ring.

2. Remove the washer (6), spring (7), and wedge (8) (**Figure 7-3, Page 7-2**).
3. Turn the steering column over and slide the shaft out of the tube to expose the retaining ring (12). Use pliers to twist the retaining ring (12) until it breaks off, then remove the wedge (8).
4. Remove the shaft (11) from the bottom of the tube (13).
5. Use steering shaft (11) to push bearing seat (10) out from the opposite end of the steering tube (13).
6. Insert a flat blade screwdriver between the bottom of the outer race of the bearing (9) and the bottom lip of the bearing seat (10) and remove the bearing (9).

**NOTE:** Use new retaining rings and bearings for reassembly.

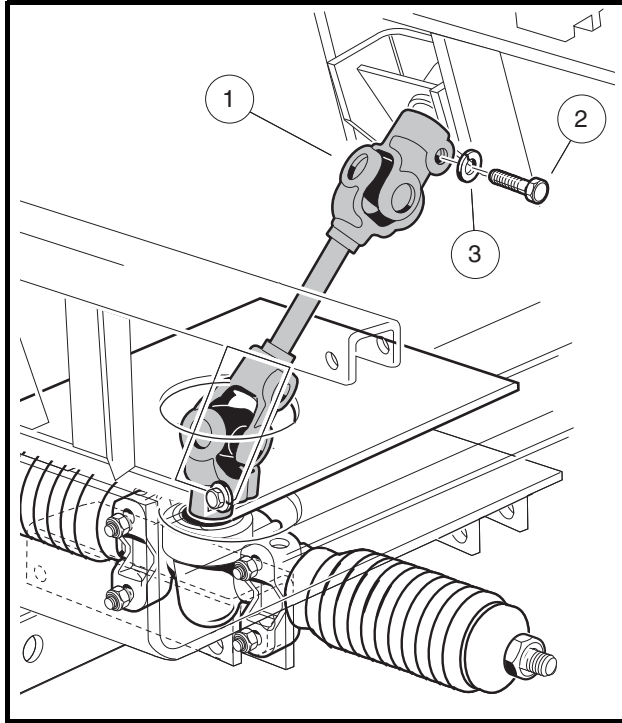


Figure 7-4 Steering Joint Assembly

## STEERING COLUMN ASSEMBLY

1. Insert bearing seat (10) into both ends of steering tube (14). Place a block of wood on bearing seat and tap lightly on block until bearing seat (10) is fully seated in steering tube (14) (**Figure 7-5, Page 7-5 and Figure 7-6, Page 7-5**).
2. Press the bearing (9) all the way into the bearing seat (10) using a steering column bearing press tool (CC P/N 1014264) or a metal tube approximately six inches (15.2 cm) long with a maximum outer diameter of 1-3/16-inches (3.3 cm) and a minimum inside diameter of 7/8-inch (2.2 cm). Be sure the bearing is installed in the bearing seat as shown (**Figure 7-5, Page 7-5**) so the wedge (8) will ride against the inner race of the bearing.
3. Install the wedge (8), spring (7), washer (6) and snap ring (5) onto the bottom end of the steering shaft (11) (**Figure 7-5, Page 7-5**).
4. Insert the shaft (11) from the bottom of the steering tube (13) (**Figure 7-3, Page 7-2**).
5. Turn the assembly over and place the shaft (11) on a bench. Install the wedge (8) and retaining ring (12) onto the top of the shaft. Be sure the prongs on the retaining ring face up and away from the wedge. Use a steering column retaining ring tool (CC P/N 1014259) to seat the retaining ring to the proper depth. Support end of tube while pressing. If you do not have the recommended tool, use the same tube as was used in step 2 to press the retaining ring onto the top of the shaft. The retaining ring should be pressed onto the shaft until 2 to 2-1/8 inches (5.1-5.4 cm) of the shaft extends from the top of the bearing seat in the steering tube (**Figure 7-6, Page 7-5**).

## STEERING COLUMN INSTALLATION

1. Install boot (14) (if previously removed) (**Figure 7-3, Page 7-2**).
2. To minimize corrosion, apply a light coat of anti-seize lubricant to both splined ends of the steering shaft.

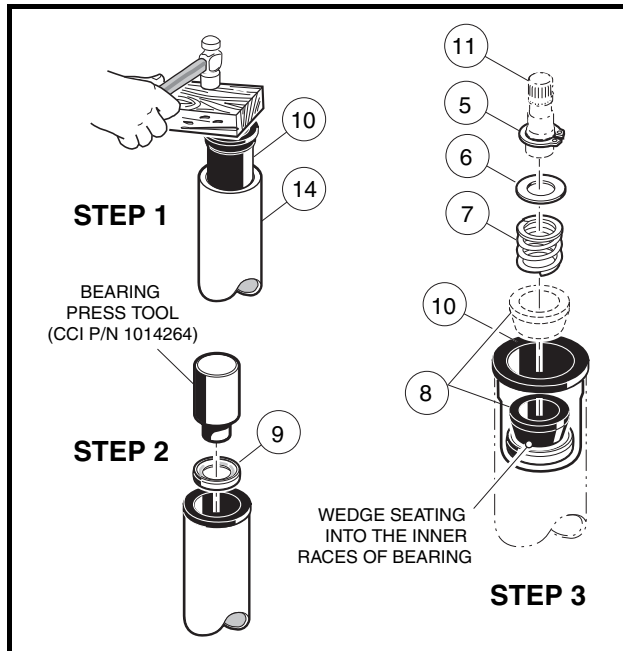


Figure 7-5 Steering Shaft–Bottom End

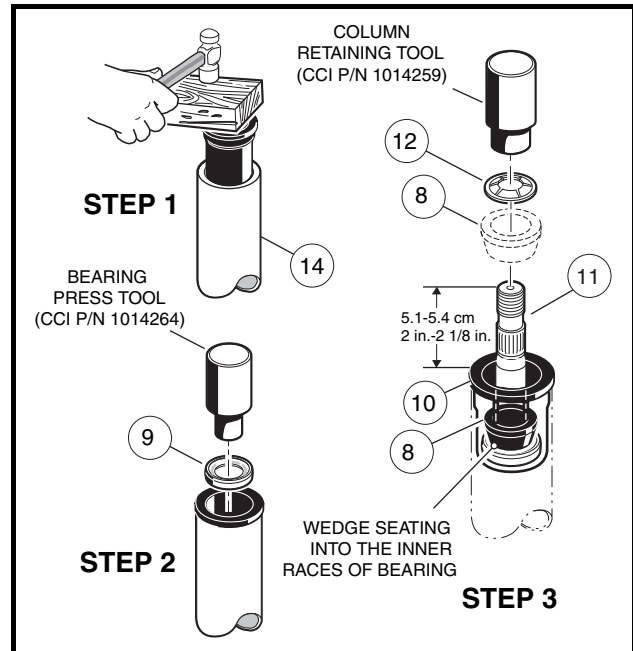


Figure 7-6 Steering Shaft–Top End

3. Position the steering column assembly in the vehicle while inserting the steering column shaft into the upper steering universal joint (1). The flat portion of the steering shaft spline (11) must be aligned with the bolt hole in the steering universal joint (1) before sliding the spline into place (**Figure 7-3, Page 7-2**).
4. Install bolt (2) and lockwasher (3) on the upper steering joint and finger-tighten (**Figure 7-4, Page 7-4**).
5. Hold the steering column in place and attach it to the frame using bolts (15), washers (16) and locknuts (17) (**Figure 7-3, Page 7-2**). Tighten the four bolts, in a crisscross pattern, to 23 ft-lb (31.2 N·m).
6. Tighten the bolt (2) on the upper steering universal joint (1) to 15 ft-lb (20 N·m).
7. Check the other bolts (27) on the lower steering universal joint assembly (1) to ensure that they are properly tightened to 15 ft-lb (20 N·m) (**Figure 7-3, Page 7-2**).
8. Install the front body. **See Front Body Installation, Section 4, Page 4-5.**
9. Install dashboard and dash panel. **See Dashboard Installation, Section 4, Page 4-3.**
10. Install the steering wheel. **See Steering Wheel Removal on page 7-1.**
11. Connect battery and spark plug wire(s). **See Connecting The Battery on page 1-3.**

## RACK AND PINION

---

See General Warning, Section 1, Page 1-1.

### **CAUTION**

- Front impacts that bend tie rods and/or drag links can possibly damage internal steering gear components. See Rack and Pinion Inspection on page 7-6. The manufacturer recommends inspecting the rack and pinion and replacing if damaged.

## RACK AND PINION INSPECTION

Look for obvious damage to the chassis, where the rack and pinion is mounted, and the rack and pinion housing. Particularly check the housing for broken mounting points.

Compare the toe-in against the specification. See **Toe-in Adjustment on page 7-13**.

If obvious visible damage is found, such as a bent tie rod, check the steering gear for abnormal free-play, noise, binding or clunking while it is under a load. With the steering system fully assembled and all four tires on the ground/floor, turn the steering wheel from stop to stop. While turning, feel for any binding, clunking or tight/loose spots. Listen for unusual noises. Replace the rack and pinion as an assembly if any is found.

In the event of an known impact and obvious visible damage is not found in the method described above, disconnect the tie rods and/or drag links from the spindles. Turn the steering wheel from stop to stop. While turning, feel for any binding or tight/loose spots. Listen for unusual noises. Replace the rack and pinion as an assembly if any is found.

## RACK AND PINION REMOVAL

1. Chock the rear wheels, release the park brake, loosen the front wheel lug nuts and lift the front of the vehicle with a chain hoist or floor jack. See **WARNING “lift only one end...” in General Warning, Section 1, Page 1-1**
2. Place jack stands under the outer front frame I-beams and lower onto stands. See **Figure 5-2, Section 5, Page 5-3**.
3. Remove the lug nuts from the front wheels.
4. Remove the cotter pins (18) and ball joint retaining nuts (24) (**Figure 7-19, Page 7-10**).
5. Remove the ball joints (23) from the spindle assemblies.
6. Remove the four bolts (20), washers (21) and nuts (22) from the steering rack and pinion assembly mounting bracket (**Figure 7-19, Page 7-10**). Also see **Figure 7-7, Page 7-7**.
7. Remove the bolt (27) and lockwasher (**Figure 7-3, Page 7-2**) from the universal joint, then remove the rack and pinion assembly and universal joint from the vehicle (**Figure 7-8, Page 7-7**).



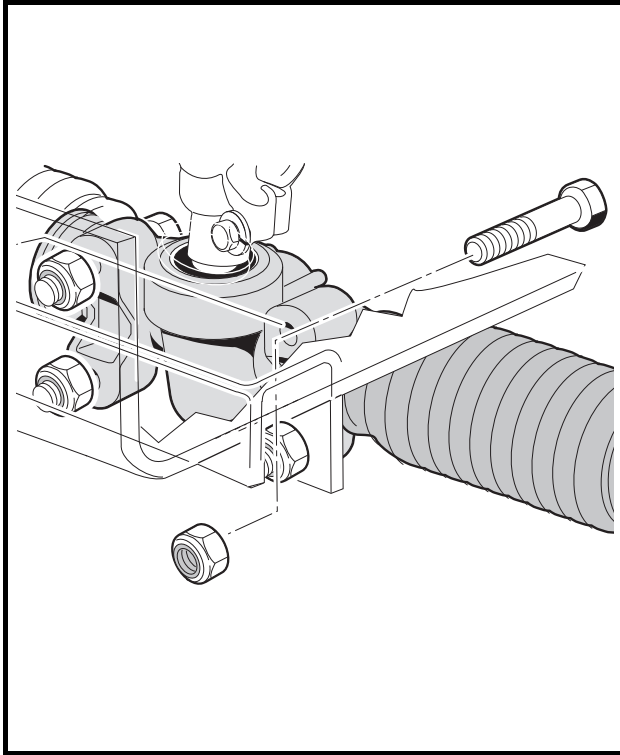


Figure 7-7 Rack and Pinion Bolts

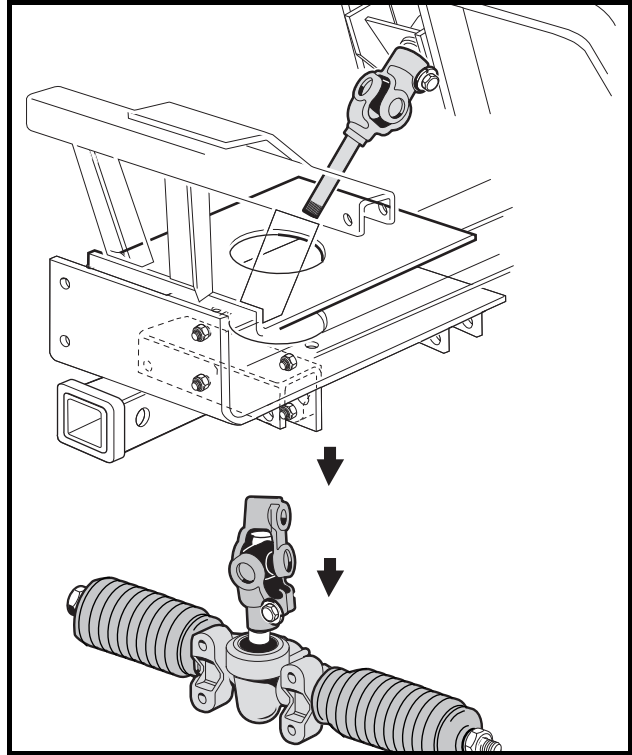


Figure 7-8 Remove Rack and Pinion

## RACK AND PINION DISASSEMBLY

1. Remove the two ball joints and inspect for excessive wear (Figure 7-9, Page 7-7).
2. Remove both drag links (Figure 7-10, Page 7-7).

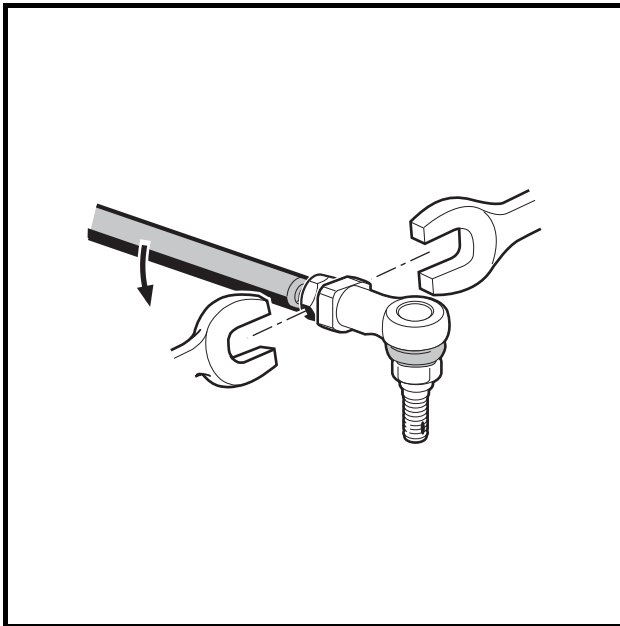


Figure 7-9 Ball Joint

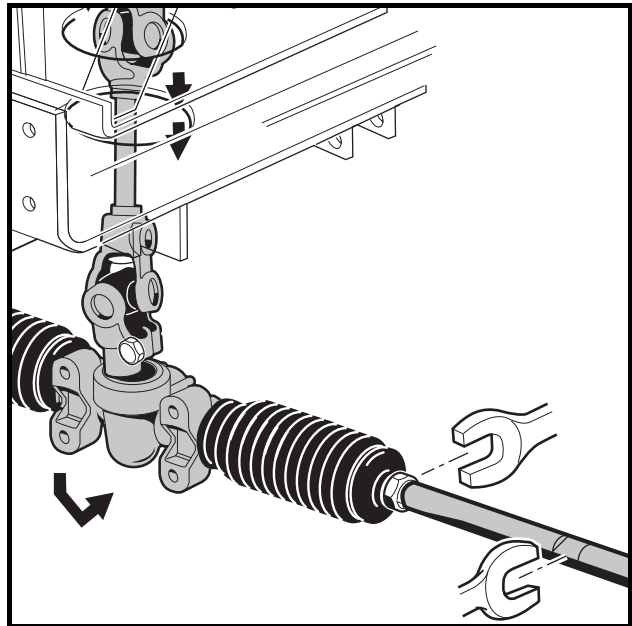
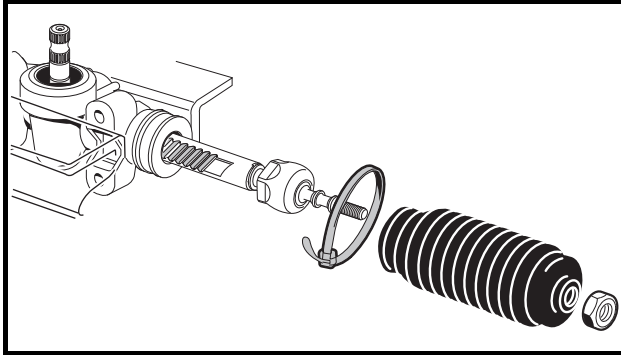


Figure 7-10 Drag Link

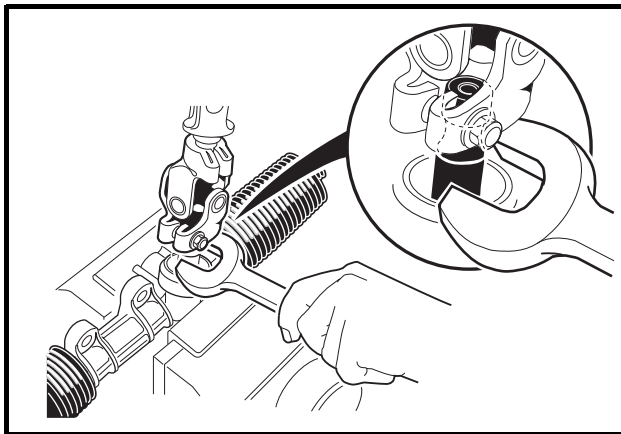
3. Remove both bellows clamps (metal clamps or plastic wire ties) (**Figure 7-11, Page 7-8**).

**NOTE:** If the dust seal bellows are secured with a metal clamp, remove the clamp. Do reuse the clamp when the rack and pinion is reassembled. Use a plastic wire tie to secure the dust seal bellows.

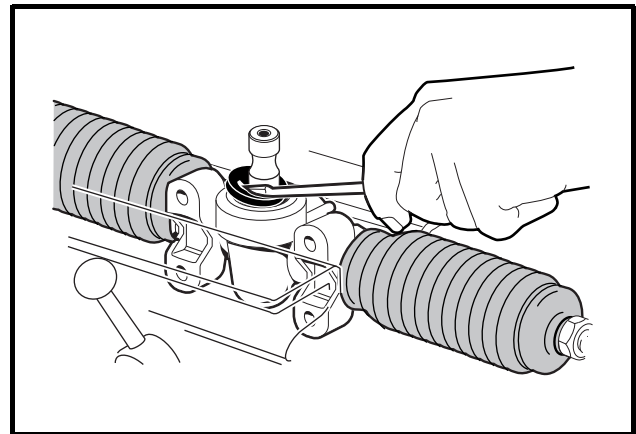


**Figure 7-11 Dust Bellows Clamp**

4. Remove the two hex nuts (12) and slide off both of the dust seal bellows (10) (**Figure 7-19, Page 7-10**).
5. Remove rack screw nut (8), rack guide screw (7), rack guide pressure spring (6) and the rack guide (5).
6. Remove the universal joint assembly from the pinion by removing the bolt and then sliding off the universal joint (**Figure 7-12, Page 7-8**).
7. Remove the dust seal (**Figure 7-13, Page 7-8**).



**Figure 7-12 Remove Universal From Pinion**



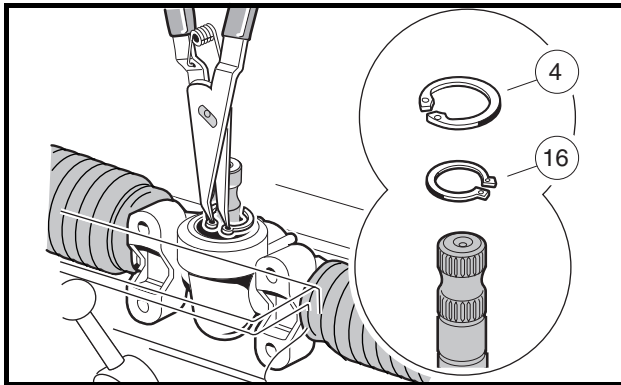
**Figure 7-13 Remove Dust Seal**

8. Remove the snap ring (**Figure 7-14, Page 7-9**).
9. Install the universal joint back onto the pinion and place a large open-end wrench under the universal joint and gently pry the pinion and bearing from the housing (**Figure 7-15, Page 7-9**).
10. If the ball bearing (15) (**Figure 7-19, Page 7-10**) has been damaged, remove the c-type stop ring (16) (**Figure 7-14, Page 7-9**) and press the bearing off (**Figure 7-16, Page 7-9**).
11. Inspect the ball joints (9) for wear. If one or both of the ball joints (9) are excessively worn, remove and replace the ball joint from the rack (**Figure 7-19, Page 7-10**).
  - 11.1. Secure the rack in a vise (**Figure 7-17, Page 7-9**). Use wood blocks between the rack and the jaws

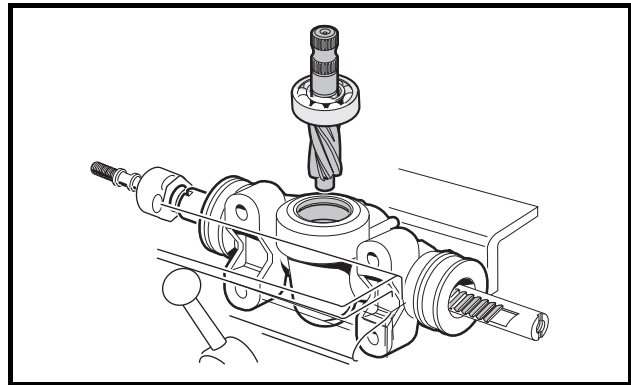
of the vise to protect the rack from damage.

11.2. Tap the flange out of the notch in the rack (**Figure 7-18, Page 7-9**).

11.3. Remove the ball joint (9) from the rack (2) (**Figure 7-19, Page 7-10**).



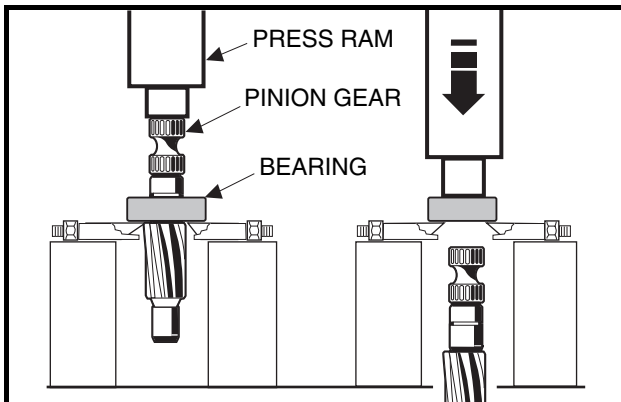
**Figure 7-14 Pinion Snap Rings**



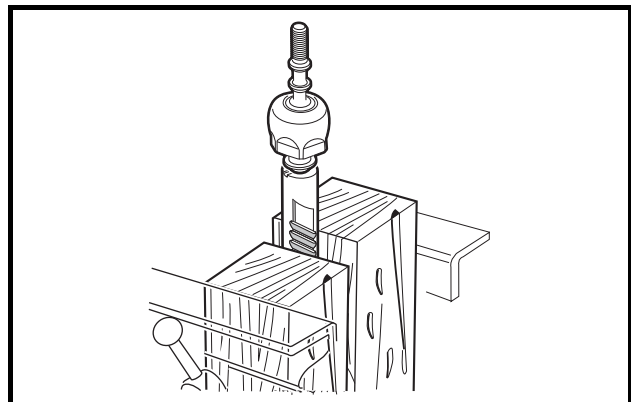
**Figure 7-15 Remove Pinion Gear Assembly**

12. Remove the rack (2) from housing (1).

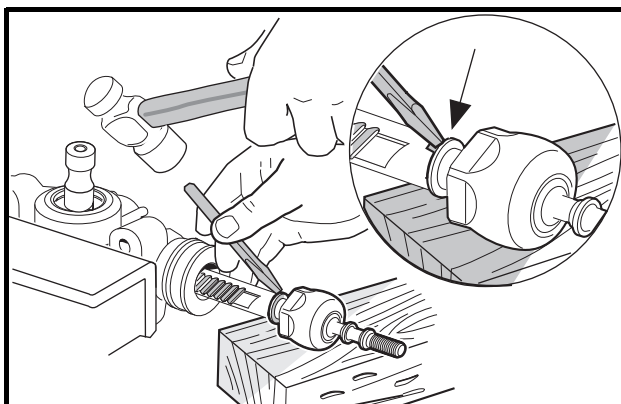
13. Inspect the bushing (17) and needle bearing (14) for excessive wear. If wear is excessive, replace the steering box assembly (CC P/N 102010101) (**Figure 7-19, Page 7-10**).



**Figure 7-16 Remove Bearing from Pinion**



**Figure 7-17 Remove Rack**



**Figure 7-18 Remove Ball Joint**

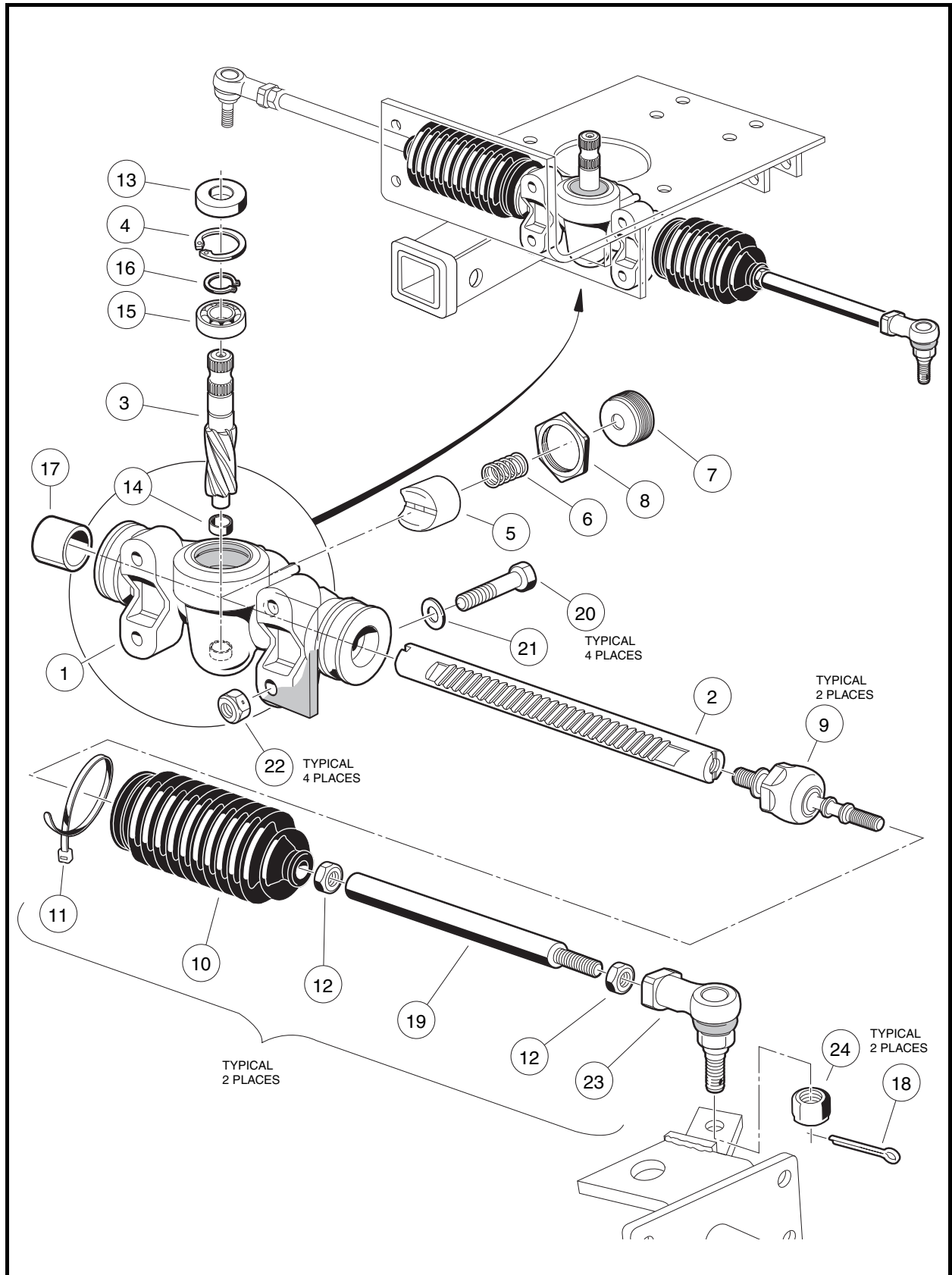


Figure 7-19 Steering Gear

## RACK AND PINION ASSEMBLY

1. Apply a liberal amount of EP grease to the teeth of the rack (2), then slide the rack through the bushing (17) and housing (1) (**Figure 7-19, Page 7-10**).

### CAUTION

- In step 2, do not press against the outer race of the bearing.
2. If the pinion bearing (15) was removed, grease a new bearing before installation. Press new bearing onto pinion shaft, exerting all pressure on the inner race. Then install the c-type stop ring (16). **See previous CAUTION.**
  3. Install pinion (3) and bearing (15) assembly into the housing (1). Make sure the rack gear teeth will mesh with the gear teeth on the pinion. The rack may need to be rotated slightly while lightly tapping on the pinion-bearing assembly with a rubber mallet. **See following CAUTION.**

### CAUTION

- Do not force the pinion-bearing assembly into the housing. The gear teeth or the small bearing could be damaged.
4. Install the snap ring (4).
  5. Use a socket to apply pressure evenly and press in a new dust seal (**Figure 7-20, Page 7-11**).
  6. Apply a small amount of grease to the rack guide (5) where it comes into contact with the rack (2) (**Figure 7-19, Page 7-10**).
  7. Install the rack end ball joints (9) onto the rack (2) by securing the rack in a vise using wood blocks between the rack and the jaws of the vise to protect the rack from damage. Tighten the ball joints to 60 ft-lb (81 N·m).
  8. Tap a flange into the notch on the rack (**Figure 7-23, Page 7-12**).
  9. Place a few drops of Loctite® 222 to the threads of the screw (7).
  10. Install the rack guide (5), pressure spring (6) and screw (7). The screw should be threaded-in until it bottoms out and then backed out 1/4 turn (**Figure 7-21, Page 7-11**).

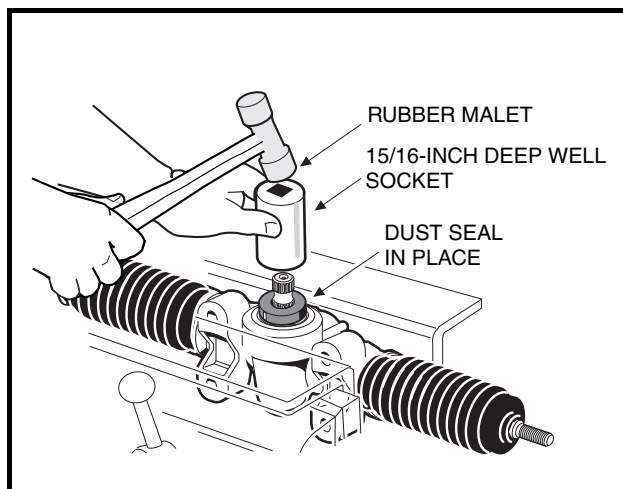


Figure 7-20 Press In Dust Seal

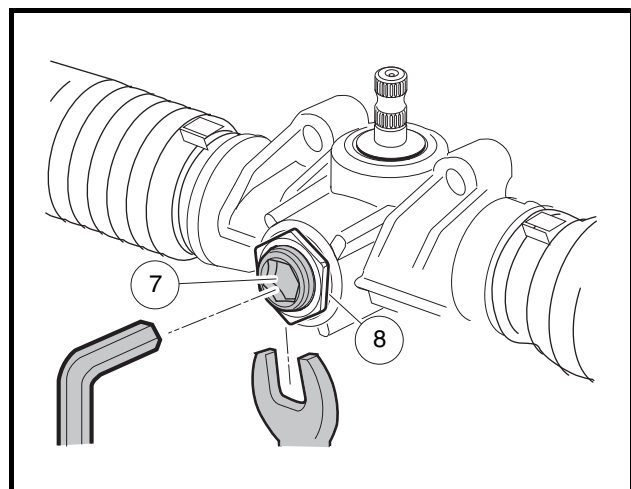
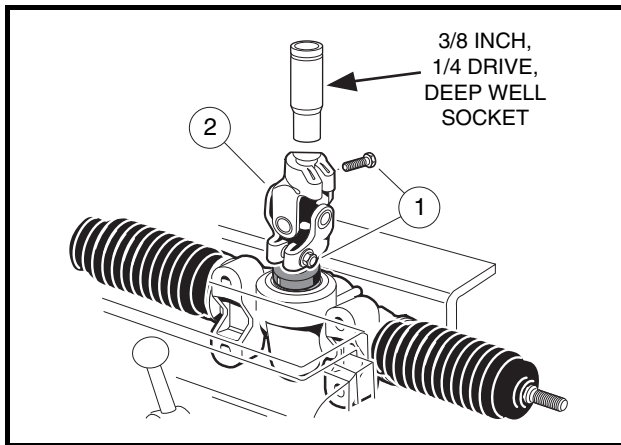


Figure 7-21 Rack and Pinion Adjustment

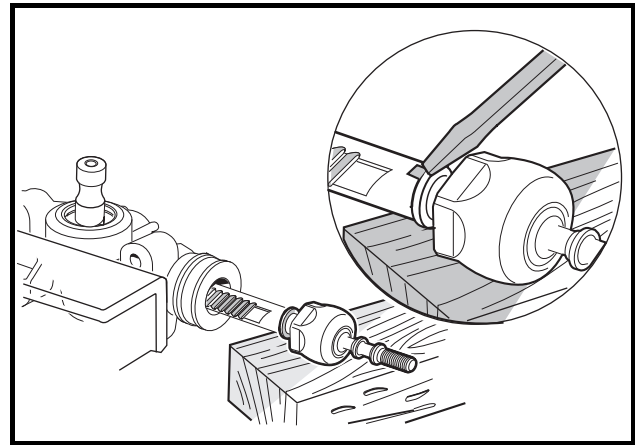
**Rack and Pinion Assembly, Continued:**

11. Insert a 3/8-inch, 1/4-drive, deep-well socket into the steering column end of the universal joint (2) and tighten the bolts (1) to 15 ft-lb (20.3 N·m) (**Figure 7-22, Page 7-12**).
12. Use a torque wrench connected to the 3/8-inch deep-well socket to measure the resistance of the rack and pinion. Rotational resistance should measure 7 to 15 in-lb (.8 to 1.7 N·m).
13. If measured resistance is not 7 to 15 in-lb (0.8 to 1.7 N·m), adjust the screw (7) until correct setting is achieved. Tighten the nut (8) to 28 ft-lb (38 N·m) (**Figure 7-21, Page 7-11**).

**NOTE:** When tightening the nut (8) make sure the screw (7) does not change adjustment (**Figure 7-21, Page 7-11**).



**Figure 7-22 Rack and Pinion Resistance**



**Figure 7-23 Install Ball Joint**

14. Install the two dust seal bellows (10).
15. Install new bellows clamps (wire ties) (11).
16. To minimize corrosion, apply a light coat of anti-seize lubricating compound to the ball joint threads.
17. Loosely install the two nuts (12) and drag links (19). Advance drag links (19) and nuts (12) onto rack end ball joints (**Figure 7-19, Page 7-10**). Nuts will be tightened during toe-in adjustment procedure.
18. Apply a light coat of anti-seize lubricating compound to the drag link threads.
19. Loosely install the two nuts (12) and ball joints (23). Advance ball joints (23) and nuts (12) into drag link ends (19) (**Figure 7-19, Page 7-10**). Nuts will be tightened during toe-in adjustment procedure.
20. Apply a light coat of anti-seize lubrication to the universal joint and install it onto the pinion shaft and tighten the bolt to 15 ft-lb (20 N·m).

**RACK AND PINION INSTALLATION**

1. To minimize corrosion, apply a light coat of anti-seize and lubricating compound to the splined portion of the steering column universal joint.
2. Align the flat portion of the shaft (1) spline with the bolt hole in the upper universal joint and then slide the shaft into the universal joint. Install the bolt (27) and lockwasher (3) and tighten to 15 ft-lb (20.3 N·m) (**Figure 7-3, Page 7-2**).
3. Position the steering rack and pinion assembly on the vehicle frame, sliding the steering universal joint up and through the hole in the mounting plate. Install the bolts (20), washers (21) and nuts (22). Using a crisscross pattern, tighten the four nuts to 20 ft-lb (27.12 N·m) (**Figure 7-19, Page 7-10**).

4. Install remaining bolt and lockwasher on the upper universal joint and tighten it to 15 ft-lb (20 N·m).
5. Check all universal joint bolts for proper torque of 15 ft-lb (20 N·m).
6. Adjust the toe-in. **See Toe-in Adjustment on page 7-13.**

## FRONT SUSPENSION

See General Warning, Section 1, Page 1-1.

### LUBRICATION

Two grease fittings are provided (one for each kingpin). Lubricate these fittings semi-annually with the proper lubricant. **See Periodic Lubrication Schedule, Section 10, Page 10-3. See following CAUTION.**

#### **▲ CAUTION**

- To ensure proper lubrication of the front suspension, raise front of vehicle to lubricate. See General Warning, Section 1, Page 1-1.

### WHEEL ALIGNMENT

Wheel alignment is limited to adjusting the toe-in of the front wheels. **See Toe-in Adjustment on page 7-13. See following NOTE.**

**NOTE:** Prior to making any front suspension adjustments, inspect components for wear or damage and repair or replace as necessary.

### Toe-in Adjustment

1. On a level surface, roll the vehicle forward, then stop. Make sure the front wheels are pointed straight ahead. Do not turn the steering wheel again during this procedure.
2. On each front tire, mark (as closely as possible) the center of the tread face that is oriented toward the rear of the vehicle. The marks should be at the same height as the center of each hub.
3. Measure the distance between the marks on the rear-facing surfaces of the tires, and then roll the vehicle forward one and one-half wheel revolutions until the marks appear on the forward-facing surfaces of the tires at the same height as the center of the hub.

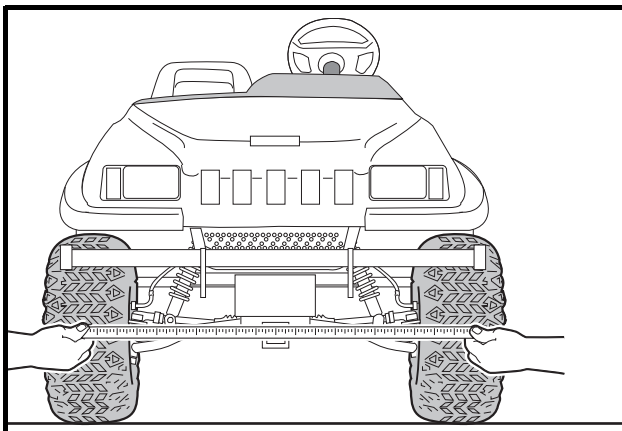


Figure 7-24 Measure Toe-in

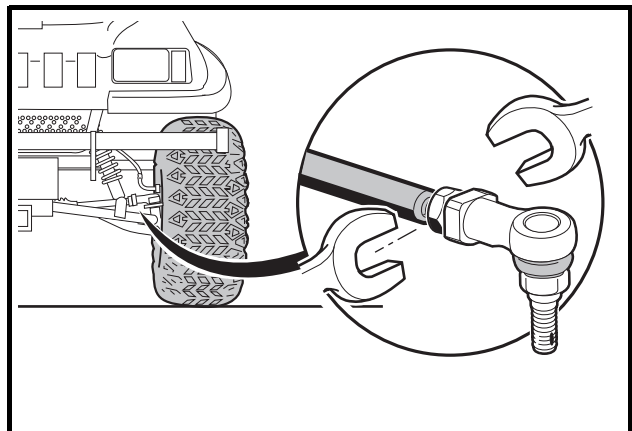


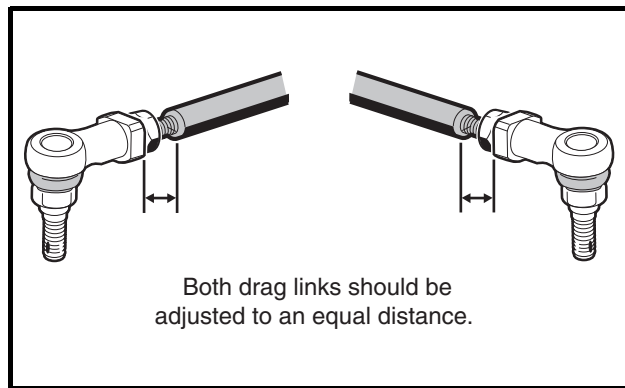
Figure 7-25 Adjust Toe-in

**Toe-in Adjustment, Continued:**

4. Measure the distance between the marks on the forward-facing surfaces of the tires (**Figure 7-24, Page 7-13**). **See following NOTE.**

**NOTE:** The front measurement must be less than the rear measurement.

5. Subtract the measurement on the front of the tires from the measurement on the rear of the tires. The difference is the toe-in. Proper toe-in is 11/16 inch  $\pm$  3/8 of an inch (18 mm  $\pm$  10 mm).
6. If adjustment is necessary:
  - 6.1. Remove the two cotter pins (18) (**Figure 7-19, Page 7-10**).
  - 6.2. Remove the locknuts (24).
  - 6.3. Rotate both of the ball joints an equal amount. To increase the toe-in, rotate both of the ball joints counterclockwise. To decrease the toe-in, rotate both of the ball joints clockwise. Maintain an equal distance from the ball joint to the end of the threads on each drag link (**Figure 7-26, Page 7-14**).
  - 6.4. Tighten the locknuts (24) to 40 ft-lb (54 N·m) (**Figure 7-19, Page 7-10**).



**Figure 7-26 Adjust Toe-in**

7. Check the toe-in. If toe-in is not adjusted properly, repeat step 6.
8. Tighten nuts (12) to 20 ft-lb (27 N·m) and recheck toe-in. Repeat step 6 for further adjustment.
9. Install new cotter pins (18).
10. After toe-in adjustment is made and with wheels in the straight ahead position, the steering wheel should be at the center of its travel. If not at the center of travel, remove and correct position. **See Steering Wheel Removal on page 7-1.**

## FRONT SUSPENSION COMPONENTS

**See General Warning, Section 1, Page 1-1.**

### KINGPIN AND STEERING SPINDLE REMOVAL

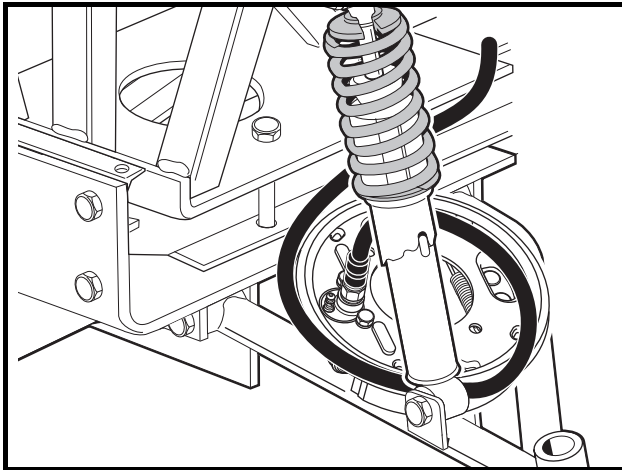
1. Remove the front brake drum. **See Front Wheel Brake Drum Removal, Section 6, Page 6-6.**
2. Remove cotter pin (18) and nut (24) and ball joint from the spindle assembly (**Figure 7-19, Page 7-10**).
3. Remove the four Torx-head bolts (18), washers (19) and locknuts (20) securing the brake cluster to the spindle assembly. **See Figure 6-3, Section 6, Page 6-7.**



4. Rest the brake cluster on the A-arm as shown (**Figure 7-27, Page 7-15**). Ensure that there is no strain on the brake hose. **See following WARNING.**

### **⚠ WARNING**

- **Strain on the brake hose or the brake hose fittings can result in damage to the hose or fittings, causing a leak in the hydraulic system, diminished brake performance, or brake failure.**



**Figure 7-27 Rest Brake Cluster on A-arm**

5. Remove the nut (22) and washer (36) and kingpin (21) (**Figure 7-28, Page 7-17**).
6. Remove the thrust washer (32).
7. Remove the wave washer (33) and inspect it. If the washer is broken or has a wave bottom to wave crest height dimension of less than 0.040 inch (0.10 cm), it must be replaced.
8. Slide the spindle assembly (20) off of the A-arm (13).
9. Repeat steps 1 through 8 for the opposite front wheel if necessary.

## **KINGPIN AND STEERING SPINDLE INSTALLATION**

1. Inspect all parts and replace them as necessary.
2. Inspect the kingpin (21) and spindle (19). If either are worn or damaged, they must be replaced (**Figure 7-28, Page 7-17**).
3. Inspect the kingpin bushings (16 and 18). If the bushings are worn or damaged, remove them and press in new ones. **See following NOTE.**

**NOTE:** *If the bushings are replaced, ream new bushings to 0.750-0.752 of an inch (19.05-19.10 mm) in diameter. The reamer should be long enough to ream both bushings from one direction.*

4. Install the spindle assembly (20) onto the A-arm (13) (**Figure 7-28, Page 7-17**).
5. Install the thrust washer (32), wave washer (33) and kingpin (21).
6. Install the washer (36) and a new locknut (22). Tighten to 18 ft-lb (24.4 N·m).
7. Insert the ball joint (23) into the spindle assembly (**Figure 7-19, Page 7-10**).
8. Install the locknut (24) and tighten to 40 ft-lb (54 N·m).

**Kingpin and Steering Spindle Installation, Continued:**

9. Install a new cotter pin (18) and bend it to secure it to the ball joint.
10. Use a grease gun and apply grease to the grease fitting (17) in the A-arm (13) (**Figure 7-28, Page 7-17**).  
**See Lubrication on page 7-13.**
11. Install the brake cluster. **See Front Brake Cluster Assembly Installation, Section 6, Page 6-17.**
12. Install the wheel and tighten the lug nuts, using a crisscross pattern, to 55 ft-lb (74.6 N·m) for steel wheels or 65 ft-lb (88 N·m) for alloy mag wheels.
13. Repeat steps 1 through 12 for the opposite front wheel if necessary.
14. Check toe-in adjustment and make adjustments if necessary. **See Toe-in Adjustment on page 7-13.**

**A-ARM REMOVAL**

1. Remove the front brake cluster. **See Front Brake Cluster Assembly Removal, Section 6, Page 6-17.**
2. Remove cotter pin (18) nut (24) and ball joint from the spindle assembly (**Figure 7-19, Page 7-10**).
3. Remove the nut (22) washer (36) and kingpin (21) (**Figure 7-28, Page 7-17**).
4. Remove the thrust washer (32).
5. Remove the wave washer (33) and inspect it. If the washer is broken or has a wave bottom to wave crest height dimension of less than 0.040 inch (0.10 cm), it must be replaced (**Figure 7-28, Page 7-17**).
6. Slide the spindle assembly (20) off of the A-arm (13).
7. Remove the lower shock absorber mounting bolt (2), nut (3) and steering stop bracket (34).
8. Remove the two bolts (10) two nuts (11) and the A-arm (13) from the suspension mounting plate.
9. Repeat steps 1 through 8 for the opposite front wheel if necessary.

**A-ARM INSTALLATION**

1. Inspect the bushings (14) and sleeves (15) in the A-arm (13) and replace if necessary (**Figure 7-28, Page 7-17**).
2. Inspect the bushings (16 and 18). If worn or damaged, remove and press in new ones. **See following NOTE.**

**NOTE:** *If the bushings are replaced, ream new bushings to 0.750-0.752 (3/4-inch) (19.05-19.10 mm) in diameter. The reamer should be long enough to ream both bushings from one direction.*

3. Install the A-arm (13) to the front suspension mounting plate using bolt (10) and nut (11) and tighten to 20 ft-lb (27 N·m) (**Figure 7-28, Page 7-17**).
4. Install the spindle assembly (20) onto the A-arm (13).
5. Install the lower shock absorber mount to the A-arm with bolt (2), nut (3) and steering stop brake hose bracket (34) (**Figure 7-28, Page 7-17**). Align the bracket (34) with the shock absorber and tighten hardware to 22 ft-lb (29.7 N·m) (**Figure 7-29, Page 7-18**).
6. Install the thrust washer (32), wave washer (33) and kingpin (21).
7. Install the washer (36) and a new locknut (22). Tighten to 18 ft-lb (24.4 N·m).
8. Insert the ball joint (23) into the spindle assembly (**Figure 7-19, Page 7-10**).
9. Install the locknut (24) to secure the ball joint to the spindle and tighten to 40 ft-lb (54 N·m).
10. Install a new cotter pin (18) and bend to secure it to the ball joint.
11. Use a grease gun and apply grease to the grease fitting (17) in the A-arm (13) (**Figure 7-28, Page 7-17**).  
**See Lubrication on page 7-13.**

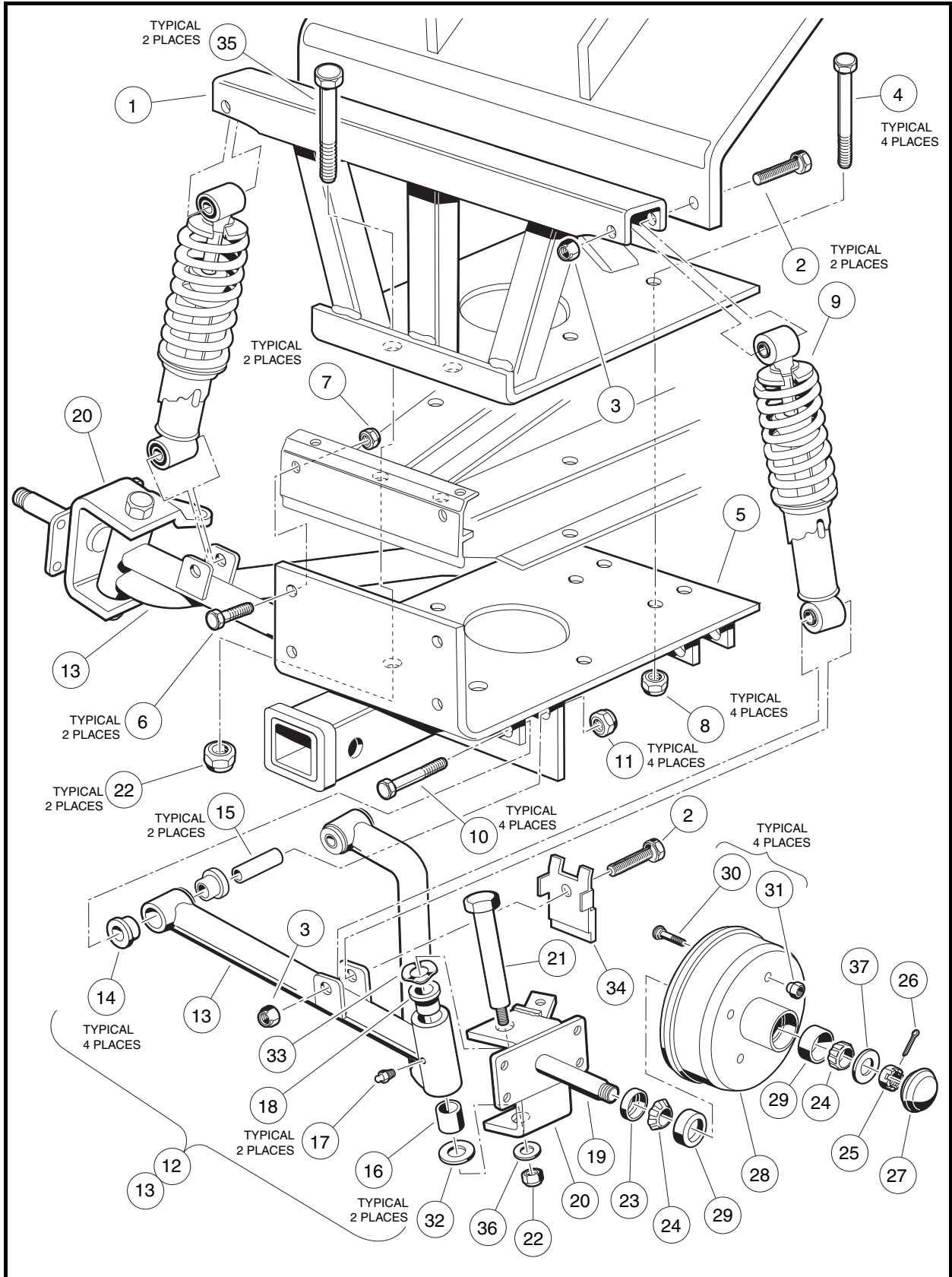


Figure 7-28 Front Suspension

**A-Arm Installation, Continued:**

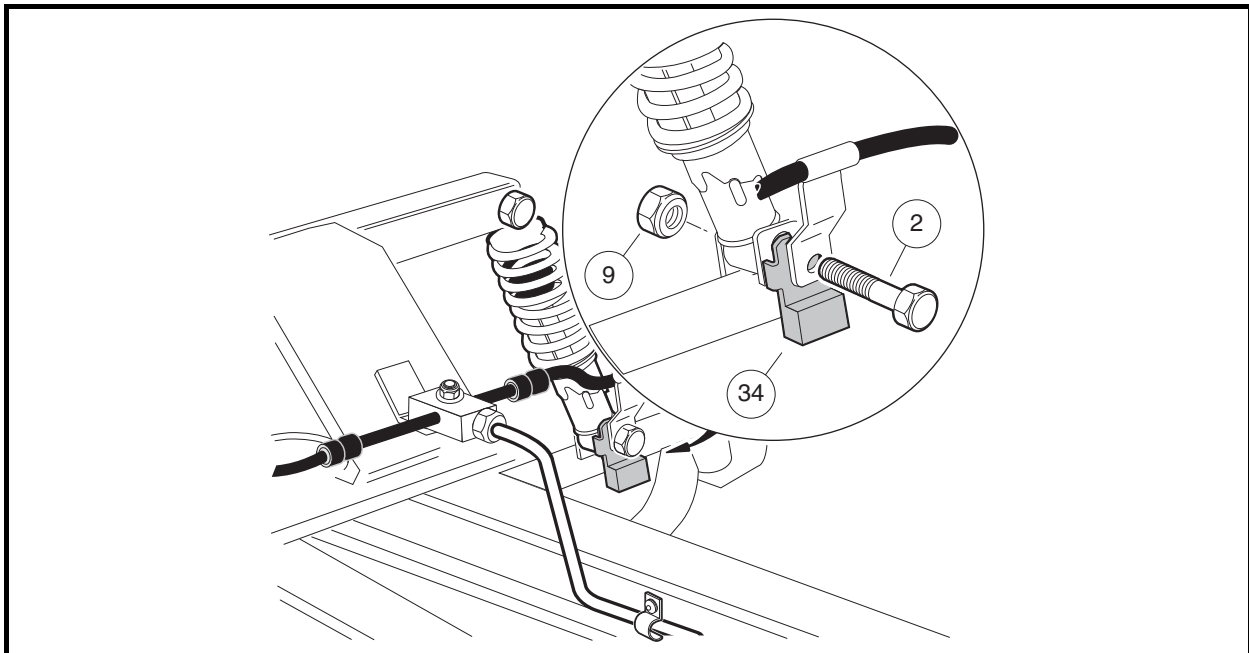
12. Install the brake cluster. **See Front Brake Cluster Assembly Installation, Section 6, Page 6-17.**
13. Install the wheel and tighten the lug nuts, using a crisscross pattern, to 55 ft-lb (74.6 N·m) for steel wheels or 65 ft-lb (88 N·m) for alloy mag wheels.
14. Repeat steps 1 through 13 for the opposite front wheel if necessary.
15. Check toe-in adjustment and make adjustments if necessary. **See Toe-in Adjustment on page 7-13.**
16. Inspect the brake hoses at the front wheels. When turning the steering wheel all the way from left to right and back again, the hoses should not come in contact with any component, especially the wheels or tires.

**SHOCK ABSORBER REMOVAL**

1. Chock the rear wheels, set the park brake, and lift the front of the vehicle with a chain hoist or floor jack. **See WARNING “Lift only one end...” in General Warning, Section 1, Page 1-2.**
2. Place jack stands under the outer front frame I-beams and lower onto jack stands. **See Figure 5-2, Section 5, Page 5-3.**
3. Inspect shock absorbers for damage or fluid leakage on the body and replace if necessary.
4. Remove the bolt (2) and nut (3) attaching the upper shock absorber mount to the A-arm (**Figure 7-28, Page 7-17**).
5. Remove the bolt (2) and nut (3) attaching the lower shock absorber mount and steering stop/brake hose bracket (34) and shock from the A-arm.

**SHOCK ABSORBER INSTALLATION**

1. Install the shock absorber by reversing the removal procedure.
2. Tighten the steering stop weldment/brake hose bracket (34) with the shock absorber and tighten hardware to 20 ft-lb (27 N·m) (**Figure 7-29, Page 7-18**).
3. Inspect the brake hoses at the front wheels. When turning the steering wheel all the way from left to right and back again, the hoses should not come in contact with any component, especially the wheels or tires.

**Figure 7-29 Shock Absorber Removal**

## FRONT WHEEL BEARINGS AND HUBS

See General Warning, Section 1, Page 1-1.

### FRONT WHEEL FREE PLAY INSPECTION

1. Chock rear wheels, loosen the front wheel lug nuts and lift the front of the vehicle with a chain hoist or floor jack. See **WARNING "Lift only one end..."** in General Warning, Section 1, Page 1-2.
2. Place jack stands under the outer front frame I-beams and lower onto jack stands. See **Figure 5-2, Section 5, Page 5-3.**

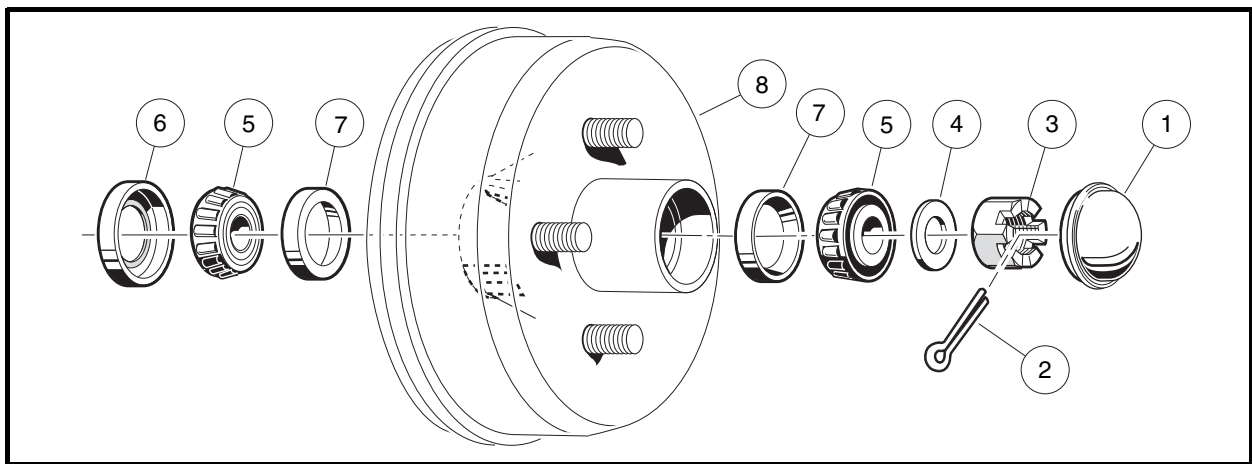


Figure 7-30 Front Wheel Bearings and Hub

3. Rock the wheel and hub assembly back and forth on the spindle. If there is any observable movement of the wheel and hub on the spindle, remove dust cap (1) and cotter pin (2) and then tighten the spindle nut (3) until both bearings (5) fully seat in the bearing cups (7) (**Figure 7-30, Page 7-19**).
4. Loosen spindle nut one cotter pin position. If the hub does not turn freely, loosen spindle nut one more cotter pin position.
5. Install a new cotter pin (2). If movement continues, replace the wheel bearings (5) as required.
6. Finger-tighten the wheel lug nuts and lower the vehicle. Tighten the lug nuts in a crisscross pattern to 55 ft-lb (74.6 N·m) for steel wheels or 65 ft-lb (88 N·m) for alloy mag wheels.

### FRONT WHEEL BEARINGS AND HUB REMOVAL

See Front Wheel Brake Drum Removal, Section 6, Page 6-6.

### FRONT WHEEL BEARINGS AND HUB INSTALLATION

See Front Wheel Brake Drum Installation, Section 6, Page 6-14.



## SECTION 8 – WHEELS AND TIRES

### **⚠ DANGER**

- See General Warning, Section 1, Page 1-1.

### **⚠ WARNING**

- See General Warning, Section 1, Page 1-1.

## GENERAL INFORMATION

- Keep tires properly inflated as follows:

<b>All Terrain Tread</b>	Front: 7-11 psi (.48-.76 Bars) Rear: 14-18 psi (.97-1.24 Bars)
<b>Turf Tread</b>	Front: 12-16 psi (.83-1.10 Bars) Rear: 16-20 psi (1.10-1.38 Bars)
<b>Traks Max II Tread</b>	Front: 14-16 psi (.97-1.10 Bars) Rear: 18-20 psi (1.24-1.38 Bars)

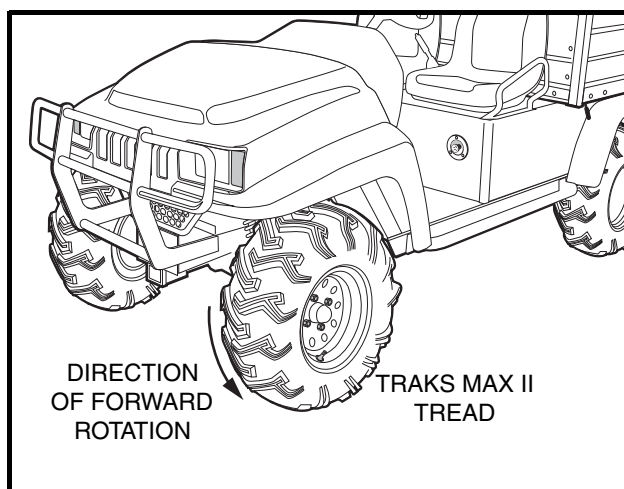
- Keep lug nuts properly tightened to 55 ft-lb (74.6 N·m) for steel wheels or 65 ft-lb (88 N·m) for alloy mag wheels.
- Keep the front end properly aligned and adjusted.
- Inspect the brake hoses at all four wheels. The hoses should not come in contact with any component, especially the wheels or tires.
- Check the park brake cables. The cables should not come in contact with the tires or wheels.

**NOTE:** An air leak could be due to a punctured tire, faulty valve core, improperly seated valve stem, or improperly seated tire bead.

Small holes in the tire can be plugged using a standard automotive tubeless tire repair kit available at auto supply stores.

Tire must be removed or installed from the valve stem side of the rim.

Traks Max II tires are directional. For optimum performance on muddy terrain, install all four tires as shown (**Figure 8-1, Page 8-1**).



**Figure 8-1 Tire Rotation**





## SECTION 9 – REAR SUSPENSION

---

### **▲ DANGER**

- See General Warning, Section 1, Page 1-1.

### **▲ WARNING**

- See General Warning, Section 1, Page 1-1.

## SHOCK ABSORBERS

---

See General Warning, Section 1, Page 1-1.

### SHOCK ABSORBER REMOVAL AND INSPECTION

1. Check shock absorbers (1) for damage or fluid leakage around the housing and replace if necessary (**Figure 9-1, Page 9-2**).
2. Remove the nut (2), cup washers (3) and rubber bushing (4) from the upper shock absorber stem.
3. Remove lower mounting hardware (6, 7 and 8) on lower mount.
4. Compress the shock absorber to remove it.

### SHOCK ABSORBER INSTALLATION

**NOTE:** When installing shock absorbers, make sure front shocks have identical part numbers and rear shocks have identical part numbers.

1. To install, reverse the removal procedure.
2. Tighten nut (2) until rubber bushings (4) expand to the same diameter as the cup washers (3) (**Figure 9-1, Page 9-2**).
3. Install mounting hardware and tighten the nut (6) until the rubber bushings (8) expand to the same diameter as the cup washers (7).

## MULTI-LEAF SPRINGS

---

See General Warning, Section 1, Page 1-1.

### MULTI-LEAF SPRING REMOVAL

1. Remove shock absorbers. **See Shock Absorber Removal and Inspection on page 9-1.**
2. Loosen the lug nuts on wheel(s) to be removed.
3. Chock the front wheels and lift rear of vehicle with a chain hoist or floor jack. If using floor jack, place jack under transaxle as shown (**Figure 9-2, Page 9-3**). **See WARNING “Lift only one end...” in General Warning, Section 1, Page 1-2**

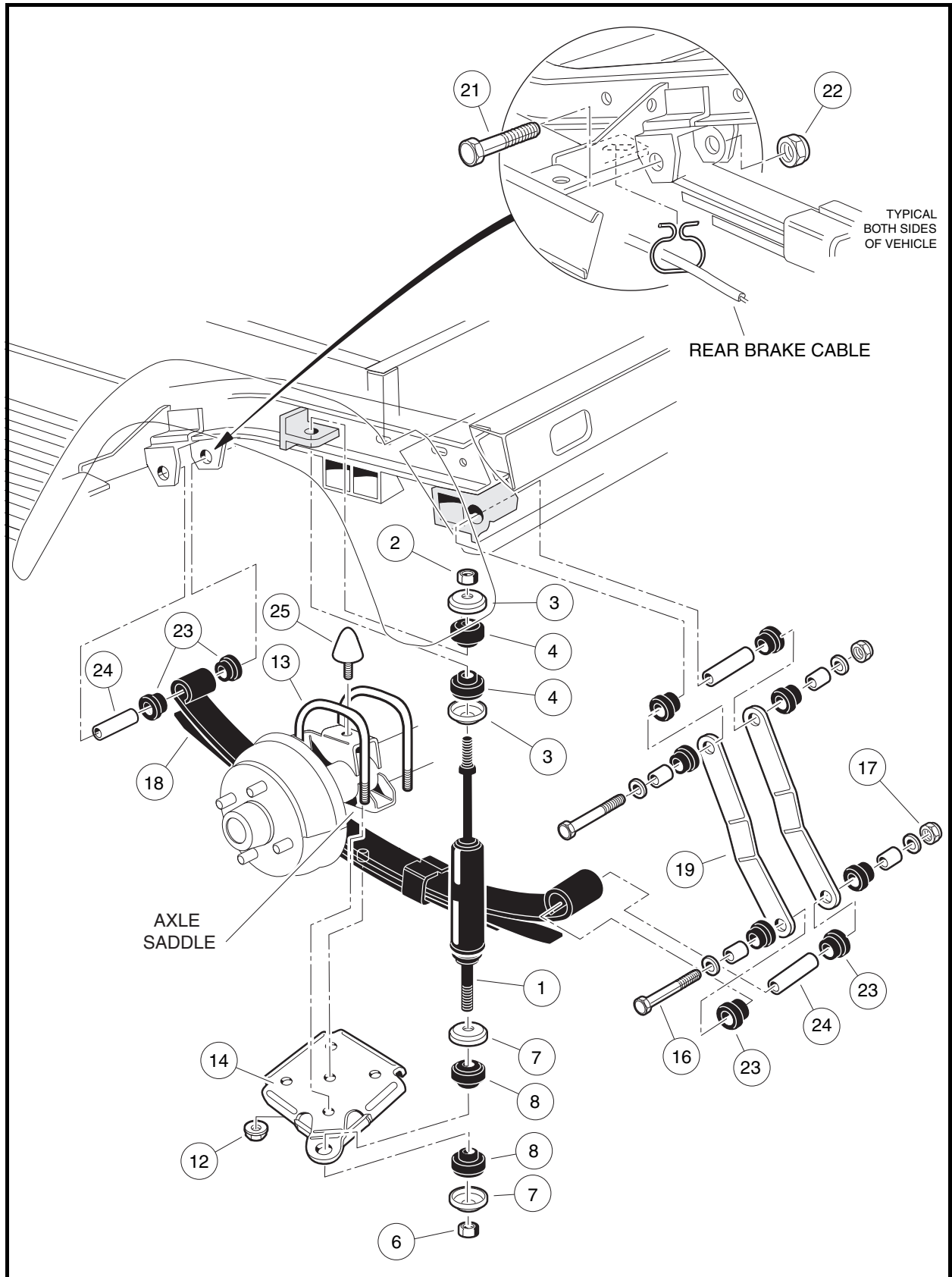


Figure 9-1 Rear Suspension for MC012C-BS00 Transaxle

**Multi-Leaf Spring Removal, Continued:**

4. Position jack stands under the two side stringers as shown (**Figure 9-3, Page 9-3**). Lower the floor jack to let the jack stands support the vehicle. See **WARNING “Lift only one end...”** in **General Warning, Section 1, Page 1-2**.

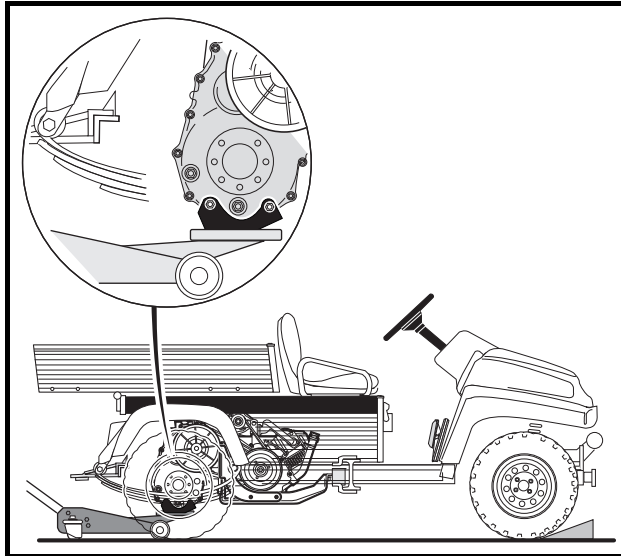


Figure 9-2 Correct Positioning of Floor Jack

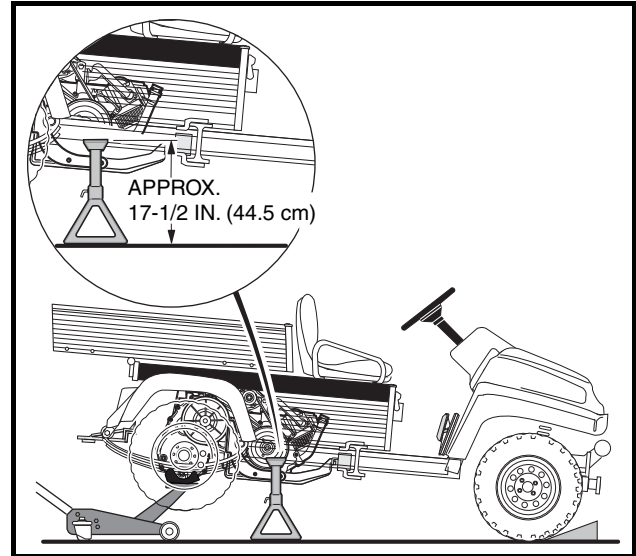


Figure 9-3 Correct Positioning of Jack Stands

5. Remove tire and wheel assembly on the side from which the spring is to be removed. Thread one lug nut onto a stud on the rear hub or bolt flange. This will keep the brake drum on the hub.
6. The jack stands should be supporting the vehicle and the floor jack should be supporting the rear suspension. Lower the floor jack until the leaf springs are unloaded but the floor jack is still supporting the axle.
7. Remove the locknuts (12) attaching the U-bolts (13) to the shock mount bracket (14) (**Figure 9-1, Page 9-2**).
8. Remove bolt (16) and locknut (17) attaching the leaf spring (18) to the rear shackles (19).
9. Allow rear of leaf spring (18) to rest on the ground and remove the bolt (21) and locknut (22) attaching the front of the spring to the vehicle frame. Remove spring from vehicle.
10. Inspect the rubber bushings (23) and steel sleeves (24) in the spring eyes and replace them if they are worn or damaged.

**MULTI-LEAF SPRING INSTALLATION**

**NOTE:** When installing leaf springs, make sure that both springs have identical part numbers.

1. Install rubber bushings (23) and steel sleeves (24) into leaf spring eyes (**Figure 9-1, Page 9-2**).
2. Place front of leaf spring (18) into front mounts and insert grade-eight bolt (21) through mount and leaf spring eye. Attach locknut (22) and tighten to 15 ft-lb (20.3 N·m). See following **CAUTION**.

**⚠ CAUTION**

- Use only grade-eight bolts for the front leaf spring mounts.

**Multi-Leaf Spring Installation, Continued:**

3. Align opposite end of leaf spring with spring shackles (19). Insert bolt (16) through shackles and leaf spring eye. Attach locknut (17) and tighten to 15 ft-lb (20.3 N·m). Lower transaxle onto leaf spring (18) (Figure 9-1, Page 9-2). See following CAUTION.

**⚠ CAUTION**

- When placing transaxle on spring, be sure to position locating bolt on the spring in the center locating hole in the axle saddle (Figure 9-1, Page 9-2).
4. Install shock mount bracket (14) onto locating bolt of leaf-spring.
  5. Install U-bolts (13) and locknuts (12) and tighten locknuts in a crisscross pattern to 35 ft-lb (47.5 N·m).
  6. Install shock absorber. See Shock Absorber Installation on page 9-1.

**SNUBBER**

See General Warning, Section 1, Page 1-1.

**SNUBBER REMOVAL**

1. Support the powertrain with a floor jack under the engine mounting plate so that the snubber is raised slightly and does not rest on the vehicle frame.
2. Working from above, remove the two bolts (2) and two locknuts (1) securing the snubber bracket to the engine mounting plate (Figure 9-4, Page 9-4).
3. Slide snubber and bracket assembly toward battery to remove it from vehicle. See following CAUTION.

**⚠ CAUTION**

- With snubber removed, the powertrain must be supported. Loss of support could result in damage to the vehicle or personal injury.

**SNUBBER INSTALLATION**

1. Install in the reverse order of removal.
2. Tighten snubber bracket mounting nuts (1) to 13 ft-lb (17.6 N·m) (Figure 9-4, Page 9-4).

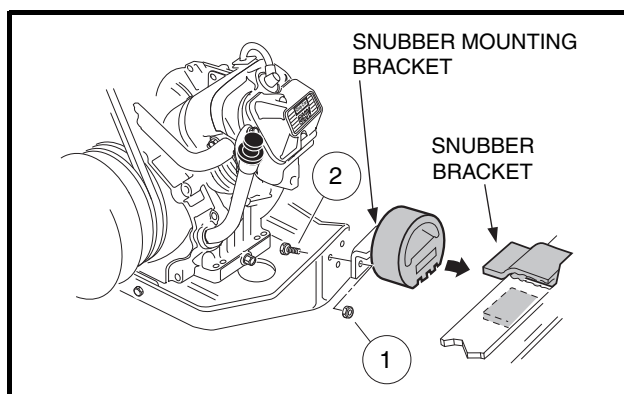


Figure 9-4 Snubber Brackets

# SECTION 10 – PERIODIC MAINTENANCE

---

## **⚠ DANGER**

- See General Warning, Section 1, Page 1-1.

## **⚠ WARNING**

- See General Warning, Section 1, Page 1-1.

## PERIODIC SERVICE SCHEDULE

---

### **⚠ WARNING**

- Service, repairs, and adjustments must be made per instructions in this maintenance and service manual.
- If any problems are found during scheduled inspection or service, do not operate vehicle until repairs are made. Failure to make necessary repairs could result in fire, property damage, severe personal injury, or death.

**NOTE:** *If the vehicle is constantly subjected to heavy use or severe operating conditions, the preventive maintenance procedures should be performed more often than recommended in the periodic service and lubrication schedules.*

*Both the Periodic Service Schedule and the Periodic Lubrication Schedule must be followed to keep the vehicle in optimum operating condition.*

PERIODIC SERVICE SCHEDULE		
REGULAR INTERVAL	SERVICE	
Daily service by owner	Pre-Operation and Daily Safety Checklist	See Pre-Operation and Daily Safety Checklist in the Owner's Manual.
	Performance Inspection	See Performance Inspection in the Owner's Manual.
Monthly service by owner or trained technician	Engine	Check engine oil level; change as required. <b>See Periodic Lubrication Schedule on page 10-3.</b>
		Check engine cooling air intake; visually inspect unshrouded area around engine exhaust for grass and debris and clean if necessary.
	Tires	Check air pressure and adjust if necessary. <b>See Section 2 – Vehicle Specifications.</b>
	General vehicle	Wash engine compartment and underside of vehicle. Do not wash engine when hot.
Semiannual service by trained technician only (or every 50 hours of operation, whichever comes first)	Battery	Clean terminals and wash dirt from casing; check electrolyte level. Add distilled water if necessary. <b>See Battery, Section 12, Page 12-39.</b>
	Front wheel alignment and toe-in	Check and adjust if necessary. <b>See Wheel Alignment on page 7-13.</b>
	Electrical wiring and connections	Check for tightness and damage.
	Brake system	Inspect master cylinder, wheel cylinders, brake lines, and hoses for damage or leakage.
Check park brake cables for damage; replace if necessary.		
Check brake shoes and drums; replace if necessary. <b>See Brake System Inspection on page 6-1.</b>		
Annual service by trained technician only (or every 100 hours of operation, whichever comes first)	Engine	Check for leaks around gaskets, fill plugs, etc.
		Inspect, clean and gap spark plug; replace if necessary.
	Engine air intake system	Check air filter element; clean or replace if necessary.
		Check clamps for tightness; check hose for cracks.
General vehicle	Check for loose hardware and tighten if necessary.	
Two year service by trained technician only (or every 200 hours of operation, whichever comes first)	Fuel filters	Replace. Dispose of used filters properly.

## PERIODIC LUBRICATION SCHEDULE

PERIODIC LUBRICATION SCHEDULE			
REGULAR INTERVAL	SERVICE	LUBRICATION POINT	RECOMMENDED LUBRICANT
Semiannually by owner or trained technician (every 50 hours of operation, whichever comes first)	Brake pedal shaft bearings	1	Dry Moly Lube (CC P/N 1012151)
	Accelerator push rod pivots, mounts, and shifter cable pivots	2	Dry Moly Lube (CC P/N 1012151)
	Front suspension (2 fittings)	3	Chassis Lube (EP NLGI Grade 2)
Annually by trained technician only (every 100 hours of operation, whichever comes first)	Check/fill transaxle to plug level	4	<b>MC012C-BS00</b> – 29 oz. (.85 liters) 80-90 Wt. API class GL-3 or 80-90 Wt. AGMA class 5 EP gear lubricant.
	Inspect front wheel bearings (Repack as necessary)	5	Chassis Lube (EP NLGI Grade 2)
First change 100 hours – additional change every 200 hours of operation or annually, whichever comes first	Change engine oil and oil filter	6	32 oz. (0.95 liter) without filter; 38 oz. (1.12 liters) with filter. <b>See Oil Viscosity on page 10-8.</b>

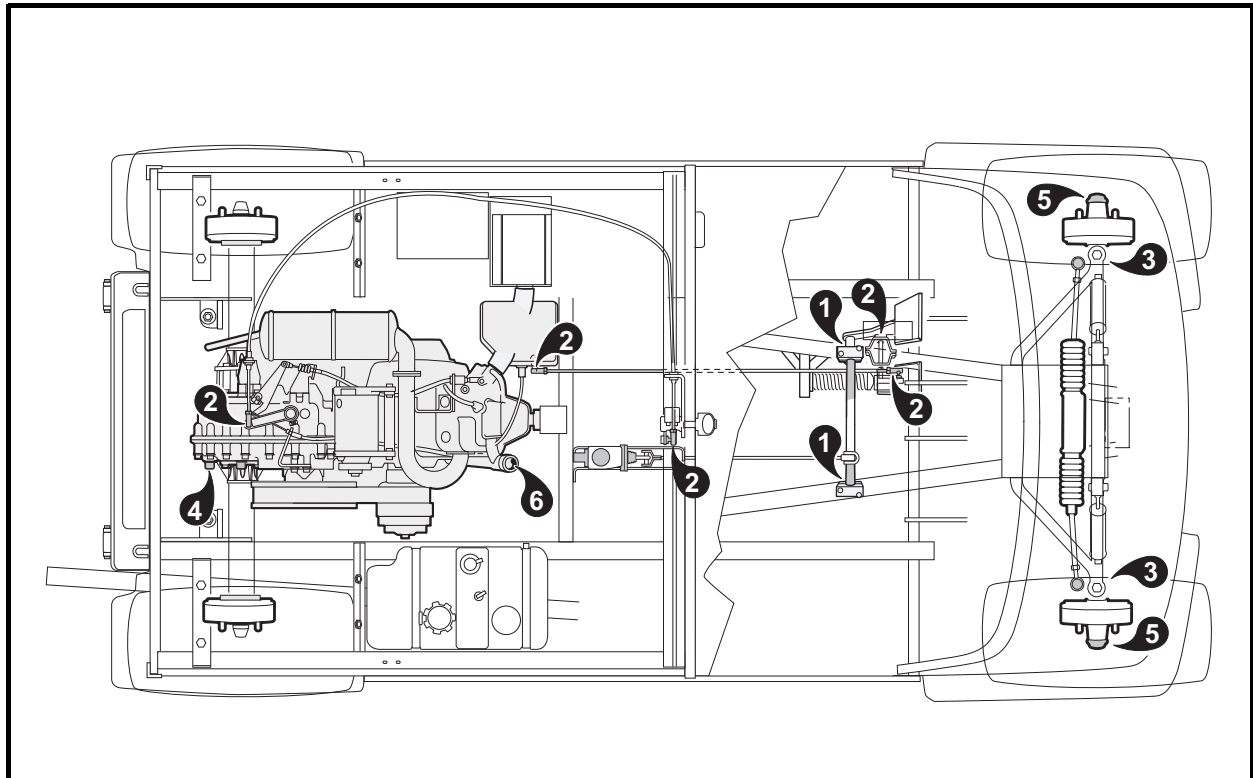
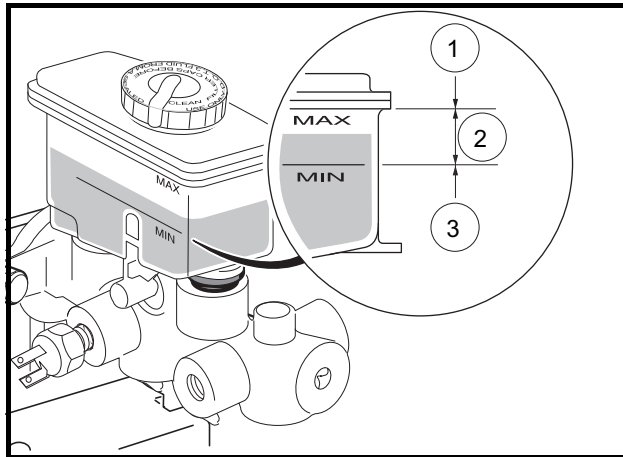


Figure 10-1 Turf 272/Carryall 272/XRT 1200 and Carryall 472/XRT 1200 SE Lubrication Points

## MASTER CYLINDER



**Figure 10-2 Brake Fluid Reservoir**

1. Full Level 2. Safe Level 3. Low Level

The master cylinder is located under the passenger seat toward the center of the vehicle (**Figure 10-2**). Raise or remove the seat to check the brake fluid level.

When checking the brake fluid, also inspect the following:

- The presence of brake fluid on the exterior surface of the master cylinder indicates a leak.
- The vent holes in the reservoir cover should be clean and open.
- The reservoir diaphragm should not have holes or other damage.

## BRAKE FLUID

Brake fluid level should be within 1/4-inch (6 mm) from top of reservoir (**Figure 10-2**). Also, brake fluid should be clean with no residue in bottom of reservoir or other evidence of contamination.

### **⚠ CAUTION**

- Use only DOT-5 (silicone) brake fluid. Use of any other type brake fluid is not recommended.

## ENGINE OIL

Even though the low oil warning light on the instrument panel should illuminate if oil becomes low, the engine oil level should be checked monthly. The vehicle should be on a level surface when checking oil. Do not over-fill with oil.

## ENGINE OIL LEVEL CHECK

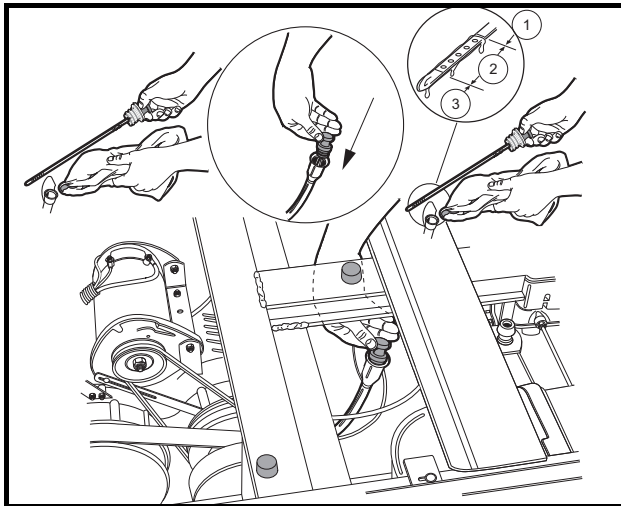
1. Remove the oil level dipstick from the oil filler tube and wipe oil from dipstick. **See Figure 10-3 or Figure 10-4. See following CAUTION.**



## **⚠ CAUTION**

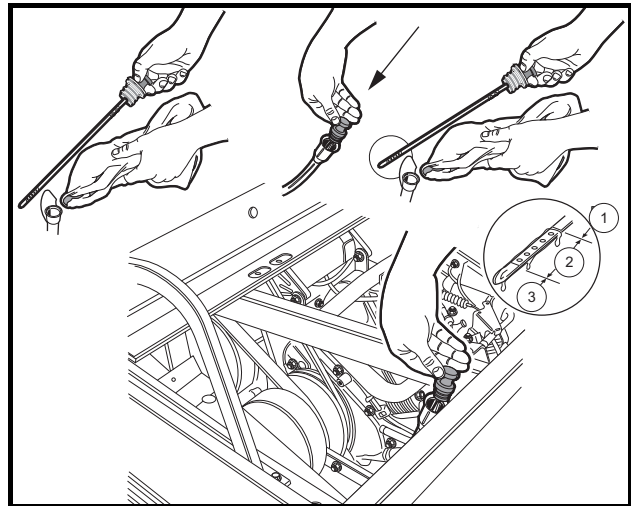
- Do not remove dipstick while engine is running.

2. Check oil by fully inserting the dipstick into the oil filler tube and immediately removing it.
3. If the oil level is at or below the low level mark on the dipstick gauge, add oil until the level is between low and full levels (safe level).



**Figure 10-3 Engine Oil Level Check –  
Turf 272/Carryall 272/XRT 1200**

1. Full Level 2. Safe Level 3. Low Level



**Figure 10-4 Engine Oil Level Check –  
Carryall 472/XRT 1200 SE**

1. Full Level 2. Safe Level 3. Low Level

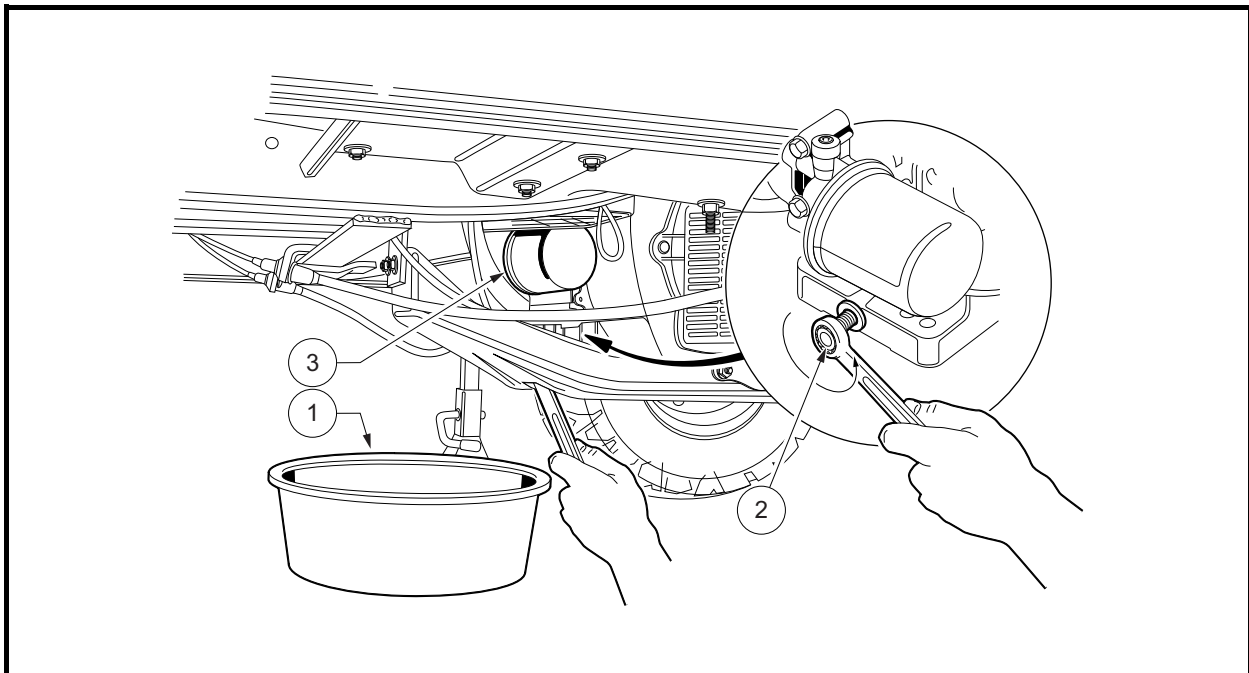
## **ENGINE OIL AND FILTER CHANGE**

Engine oil and oil filter should be changed after the first 100 hours of operation. After that, they should be changed every 200 hours of operation or annually, whichever comes first.

1. Turn the key switch to the OFF position, then remove the key. Place the Forward//Reverse handle in the NEUTRAL position. Chock the front wheels.
2. Access the engine compartment. **See WARNING “For vehicles with cargo beds...” on page 1-2.**
  - **Turf 272/Carryall 272/XRT1200:**
    - 2.1. Tilt the bed and ensure that the prop rod is properly engaged.
  - **Carryall 472/XRT 1200 SE:**
    - 2.2. Remove the rear bench seat.
3. Disconnect battery and spark plug wire(s). **See Disconnecting The Battery on page 1-3.**
4. Position a pan designed for oil changes under the front drain plug (**Figure 10-5**).
5. Use a 14 mm socket or wrench to remove the drain plug, turning it counterclockwise, and allow the engine oil to drain into the pan. **See following WARNING.**

## **⚠ WARNING**

- Do not attempt to change engine oil when the engine is hot or even warm. Engine oil can cause skin burns.
  - Wear safety glasses or approved eye protection when servicing the vehicle. Wear rubber gloves when handling oil drain plug, oil filter, and oil drain pan.
6. Clean the oil drain plug threads with solvent to remove oil and oil residue. Make sure that the compression washer remains on the drain plug.
  7. Use a 14 mm socket or wrench and replace the front oil drain plug, turning it clockwise, and tighten to 18 ft-lb (24.4 N·m).



**Figure 10-5 Engine Oil Drain Plug and Pan**

1. Drain pan 2. Drain plug 3. Oil filter

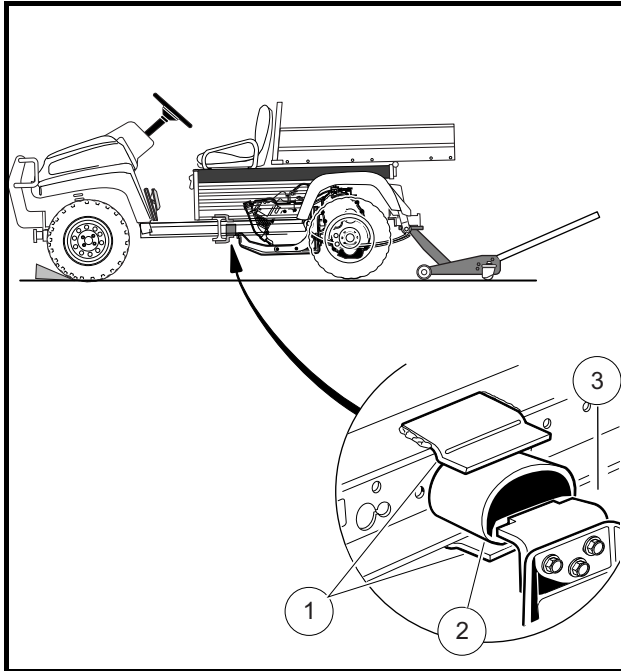
8. Place a floor jack under the rear receiver hitch where the hitch and body frame are fastened. Lift the vehicle body slightly, allowing the front of the engine to tilt slightly downward. This will allow the oil filter more clearance under the electrical component box (**Figure 10-6**).
9. Relocate the oil drain pan to a position under the engine oil filter (**Figure 10-7**).
10. Remove the engine oil filter, turning it counterclockwise, allowing the residual oil in the filter port and filter to drain into the oil drain pan. **See following NOTE**

**NOTE:** An oil drip guard can be used to prevent excess oil from dripping into the engine base plate. Use an empty quart (one liter) container and cut the bottom off at an angle, then slide the open area of the container up and under the oil filter prior to removing. Position the port of the plastic container so oil will be directed into the oil pan (**Figure 10-7, Page 7**). A drip guard can be made by folding a piece of cardboard, thin metal, or plastic under the oil filter forming a channel to direct the filter port oil into the drain pan.

Dispose of used oil according to the environmental laws and regulations for your area.

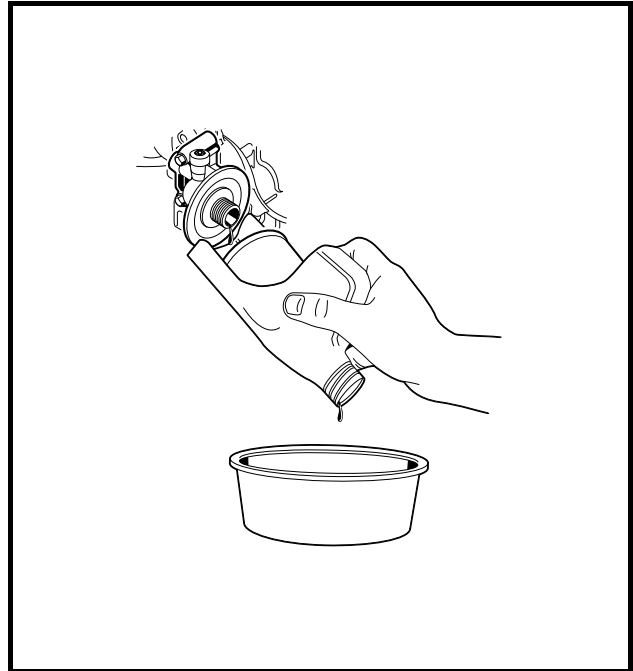
11. Use a clean rag and wipe the oil filter mounting bracket surface clean where the oil filter gasket seats.
12. Coat new oil filter gasket with clean engine oil and install the oil filter onto the engine oil filter port (Figure 10-8). See following NOTE.

**NOTE:** Use only Club Car oil filters (CC P/N 1016467) designed for this engine.

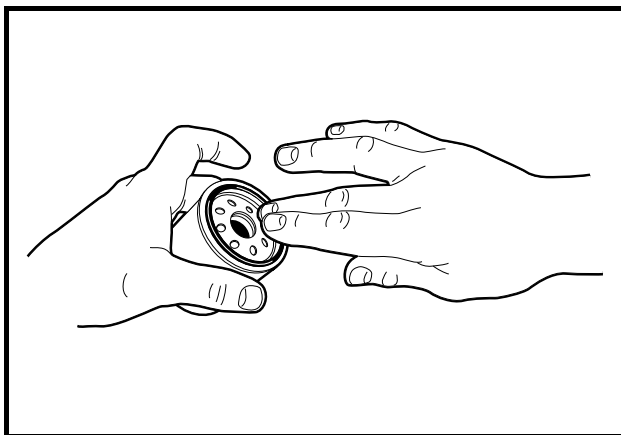


**Figure 10-6 Compress Snubber Downward**

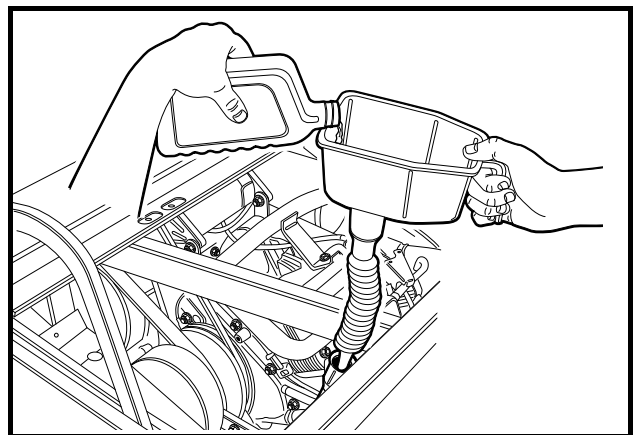
1. Snubber Bracket 2. Snubber 3. Compress Down



**Figure 10-7 Remove Engine Oil Filter**



**Figure 10-8 Coat Rubber Seal**



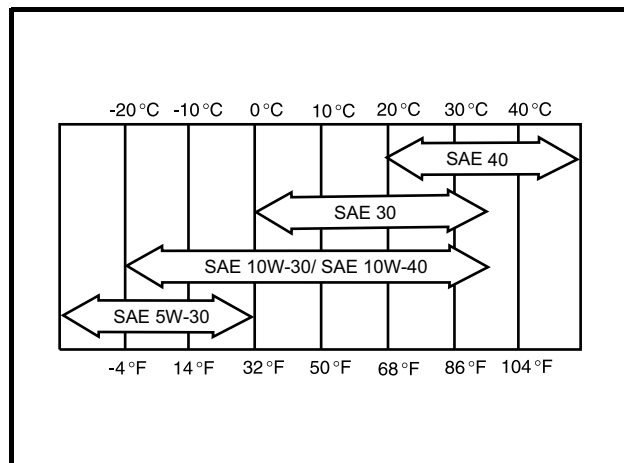
**Figure 10-9 Add Engine Oil**

13. Hand tighten 2/3 to 3/4 turn after filter gasket contacts mounting surface.
14. Lower the vehicle and remove the floor jack from under the rear of the vehicle.

15. Remove the dipstick and add engine oil into the dipstick port. Use a funnel or pour spout to direct the oil into the dipstick port (**Figure 10-9**). With filter change, the engine requires 38 ounces (1.12 liters) of oil per change. Refer to oil viscosity guidelines for selection of oil grade (**Figure 10-10**). Replace the dipstick.
16. Connect battery and spark plug wire(s). **See Connecting The Battery on page 1-3.**
  - **Turf 272/Carryall 272/XRT 1200:**
    - 16.1. Lower the cargo bed. **See WARNING “For vehicles with cargo beds...” on page 1-2.**
  - **Carryall 472/XRT 1200 SE:**
    - 16.2. Replace the rear bench seat.
17. With the Forward/Reverse handle in the NEUTRAL position, run engine for 3 minutes and check for leaks. Observe both the drain plug and the oil filter from under the vehicle and watch for oil leaks. If filter leaks, tighten additional 1/4 turn and retest. If oil drain plug leaks, re-torque and retest.
18. Remove the dip stick and check the engine oil as a final step. Replace the dip stick.

## OIL VISCOSITY

Choose the viscosity according to the temperature as indicated by the oil viscosity chart (**Figure 10-10**).



**Figure 10-10 Oil Viscosity Chart**

**NOTE:** Using multi-grade oils (5W-20, 10W-30, and 10W-40) will increase oil consumption. Check oil level more frequently when using them.

## FUELING INSTRUCTIONS

Read General Warning, Section 1, Page 1-1

### **⚠ DANGER**

- Turn the key switch to the OFF position before fueling.
- Do not pour fuel into the fuel tank when the engine is hot or while it is running.

**DANGER CONTINUED ON NEXT PAGE...**

**⚠ DANGER**

- To help avoid electric arc caused by static electricity, the fuel storage/pumping device must be grounded. If the pump is not grounded, the vehicle must be grounded to the pump before and during the fueling operation.
- If vehicle has an all-weather enclosure installed, be sure the fuel tank is properly vented as shown (Figure 10-11, Page 9 or Figure 10-12, Page 9).
- To help avoid the possibility of fire, clean up any spilled fuel before operating the vehicle.

**⚠ CAUTION**

- To allow for expansion, do not fill higher than 2.54 cm (one inch) from the top of the fuel tank. Avoid spilling fuel.

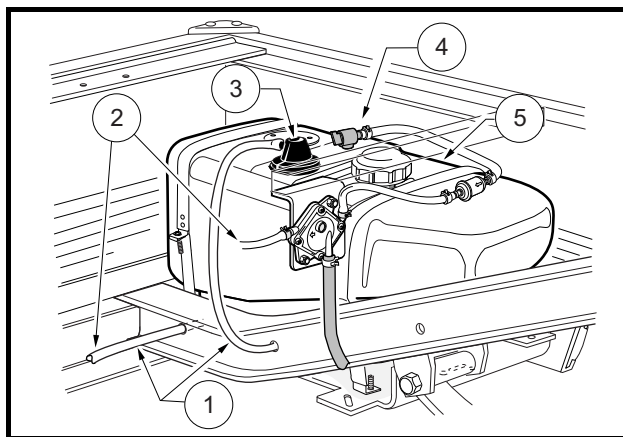
1. Remove the passenger seat.
2. Remove fuel cap and fill tank with fresh unleaded gasoline only. **See preceding DANGER and CAUTION.**

**NOTE:** Whenever possible, avoid using oxygenated fuels and fuels that are blended with alcohol. Vehicles to be stored for extended periods should be prepared for storage as instructed. **See Preparing The Vehicle For Extended Storage on page 3-2.**

3. Replace fuel cap on tank. Ensure cap is tightened securely.
4. Clean any spilled fuel from the tank top and around the tank area.
5. Replace passenger seat.

**⚠ WARNING**

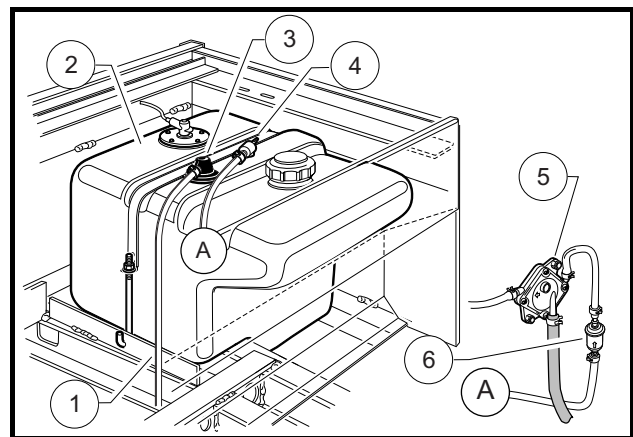
- Make sure seat hinges and latch are securely engaged before operating vehicle.



**Figure 10-11 Fuel Tank – Turf 272/Carryall 272/XRT 1200**

1. Vent Tube\* 2. To Carburetor 3. Vent 4. Fuel Shut-off Valve 5. Fuel Tank

\*Vehicle without carbon canister shown.



**Figure 10-12 Fuel Tank – Carryall 472/XRT 1200 SE**

1. Vent Tube 2. Fuel Tank 3. Vent 4. Fuel Shut-off Valve 5. Fuel Pump (under rear seat) 6. Fuel Filter (under rear seat)

## BATTERY

---

Read General Warning, Section 1, Page 1-1

### **⚠ DANGER**

- **Battery – Explosive gases! Do not smoke. Keep sparks and flames away from the vehicle and service area. Ventilate when charging or operating vehicle in an enclosed area. Wear a full face shield and rubber gloves when working on or near batteries.**
- **Tools, wires and metal objects can cause sparks when shorted across a battery. Follow all instructions carefully when working with batteries.**
- **Charge battery in a well-ventilated area only.**
- **Battery – Poison! Contains acid! Causes severe burns. Avoid contact with skin, eyes or clothing. Antidotes:**
  - **External: Flush with water. Call a physician immediately.**
  - **Internal: Drink large quantities of milk or water followed with milk of magnesia or vegetable oil. Call a physician immediately.**
  - **Eyes: Flush with water for 15 minutes. Call a physician immediately.**

### **⚠ WARNING**

- **Do not jump-start a dead battery using another battery and jumper cables.**

The battery in a Club Car vehicle is a 12-volt, low-maintenance battery that requires infrequent checks (**Figure 10-13**). Electrolyte level should be checked semiannually.

1. Turn the key switch to the OFF position and remove the key. Place the Forward/Reverse handle in the NEUTRAL position. Chock the wheels.
2. Access the engine compartment. **See WARNING “For vehicles with cargo beds...” on page 1-2.**
  - **Turf 272/Carryall 272/XRT 1200:**
    - 2.1. Tilt the bed and ensure that the prop rod is properly engaged.
  - **Carryall 472/XRT 1200 SE:**
    - 2.2. Remove the rear bench seat.
3. Disconnect battery and spark plug wire(s). **See Disconnecting The Battery on page 1-3.**
4. Use a flat blade screwdriver, and carefully remove the battery cell caps from the battery (**Figure 10-13**). **See following WARNING.**

### **⚠ WARNING**

- **Wear safety glasses or approved eye protection when servicing the vehicle. Wear a full face shield and rubber gloves when working on or near batteries.**
5. Carefully check the electrolyte level and add distilled water if necessary. Do not fill above designated fill line. Replace battery cell caps.
  6. Clean both battery terminals with a solution of baking soda and water (1 cup (237 mL) baking soda per gallon (3.8 L) of water). Rinse thoroughly. Do not allow this solution to enter the battery. Tighten battery terminals to 80 in-lb (9 N·m). Let the terminals dry and then spray them with Battery Terminal Protector Spray (CC P/N 1014305). **See following CAUTION.**

**CAUTION**

- If battery wire terminals are damaged or corroded, replace or clean them as necessary. Failure to do so may cause them to overheat during operation and could result in fire, property damage, or personal injury.

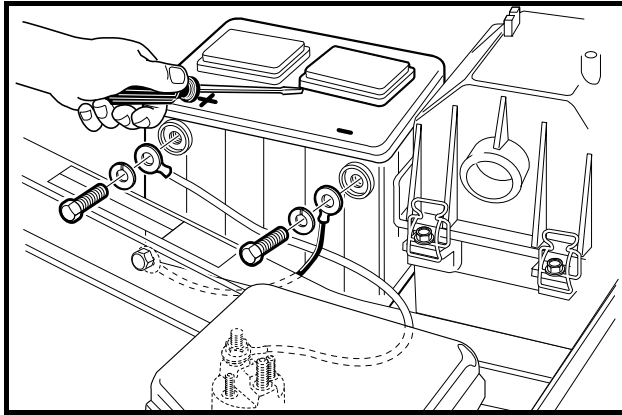


Figure 10-13 Battery

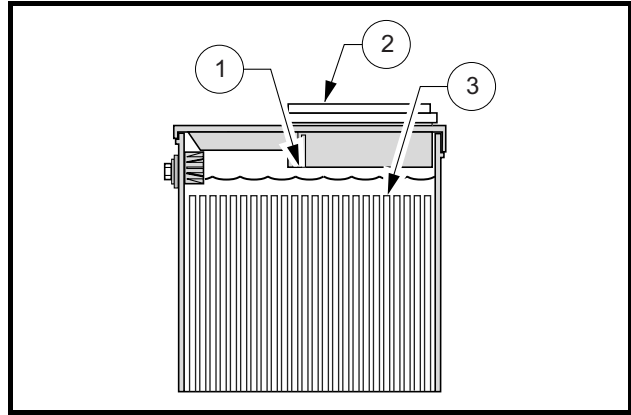


Figure 10-14 Battery Electrolyte Level

1. Level Indicator 2. Cap 3. Plates  
Electrolyte level at least 1/2 inch (13 MM) above plates or to level indicator.

Be sure battery hold-down clamp is properly tightened. Tighten to 144 in-lb (16 N·m). A loose clamp may allow the battery to become damaged from vibration or jarring.

If battery appears weak, have it charged by a trained technician. The battery should never be left discharged any longer than absolutely necessary (do not leave discharged overnight).





# SECTION 11 – TROUBLESHOOTING AND ELECTRICAL SYSTEM: FE400, KEY-START ENGINE

## **⚠ DANGER**

- See General Warning, Section 1, Page 1-1.

## **⚠ WARNING**

- See General Warning, Section 1, Page 1-1.

## TROUBLESHOOTING GUIDE

The following troubleshooting guide will be helpful in identifying operating difficulties should they occur. The guide includes the symptom, probable cause(s) and suggested checks. The procedures used in making these checks can be found in the referenced sections of this maintenance and service manual.

TROUBLESHOOTING GUIDE		
SYMPTOM	POSSIBLE CAUSES	REFER TO
<b>Engine does not start easily.</b>	Spark plug is partially fouled or in poor condition	Section 13 – FE400 Engine
	Spark plug wire is damaged or loose	Section 13 – FE400 Engine
	Loose wire connection at ignition coil or RPM limiter	Section 11 – Troubleshooting and Electrical System: FE400, Key-Start Engine, Test Procedures 14, 15, and 16
	Intermittent ignition coil failure	Section 11 – Troubleshooting and Electrical System: FE400, Key-Start Engine, Test Procedures 14, 15, and 16
	Low cylinder compression	Section 13 – FE400 Engine
	Water or dirt in the fuel system and/or carburetor; dirty or clogged fuel filter	Section 14 – Fuel System
	Carburetor improperly adjusted	Section 14 – Fuel System
	Starter/generator belt is slipping	Section 12 – Electrical Components: FE400, Key-Start Engine Belt Tension Adjustment on page 12-9
<b>Engine starts but does not run smoothly.</b>	Spark plug is fouled or in poor condition	Section 13 – FE400 Engine
	Spark plug wire is damaged or loose	Section 13 – FE400 Engine
	Intermittent ignition coil failure	Section 11 – Troubleshooting and Electrical System: FE400, Key-Start Engine, Test Procedures 14, 15, and 16
	Water or dirt in the fuel system and/or carburetor; dirty or clogged fuel filter	Section 14 – Fuel System
	Fuel pump malfunction; fuel pressure to carburetor too low	Section 14 – Fuel System
<b>Troubleshooting Guide continued on next page...</b>		

<b>TROUBLESHOOTING GUIDE</b>		
<b>SYMPTOM</b>	<b>POSSIBLE CAUSES</b>	<b>REFER TO</b>
<b>Engine turns but fails to start.</b>	Fuel tank is empty	Section 14 – Fuel System
	Fuel line or filters clogged	Section 14 – Fuel System
	Fouled spark plug	Section 13 – FE400 Engine
	Spark plug wire damaged or loose	Section 13 – FE400 Engine
	Loose wire connection at ignition coil or RPM limiter	Section 11 – Troubleshooting and Electrical System: FE400, Key-Start Engine, Test Procedures 14, 15, and 16
	Engine flooded with fuel as result of excess choking	See Owner's Manual, Controls and Indicators. See Choke.
	Fuel pump malfunction or failure	Section 14 – Fuel System
	Ignition coil or RPM limiter failed	Section 11 – Troubleshooting and Electrical System: FE400, Key-Start Engine, Test Procedures 14, 15, and 16
	Kill circuit grounded	Section 11 – Troubleshooting and Electrical System: FE400, Key-Start Engine, Test Procedures 14, 15, and 16
<b>Engine overheats.</b>	Fan screen is partially blocked or plugged	See the Engines and Transaxles manual (CC P/N 102396501)
	Governor is improperly adjusted	Section 14 – Fuel System
	Carburetor is too lean; check main jet size	Section 14 – Fuel System
<b>Engine pre-ignites.</b>	Excessive carbon deposits on piston head or in combustion chamber	See the Engines and Transaxles manual (CC P/N 102396501)
	Spark plug heat range is incorrect	Section 13 – FE400 Engine
	Unsuitable or contaminated fuel	Section 14 – Fuel System
<b>Loss of engine power.</b>	Exhaust valve is restricted with carbon deposit	See the Engines and Transaxles manual (CC P/N 102396501)
	Muffler or exhaust pipe restricted with carbon or other substance	Section 15 – Exhaust System
	Ignition coil failed	Section 11 – Troubleshooting and Electrical System: FE400, Key-Start Engine, Test Procedures 14, 15, and 16
	Air filter is dirty or clogged	Section 14 – Fuel System
	Governor is improperly adjusted	Section 14 – Fuel System
	Throttle linkage out of adjustment	Section 14 – Fuel System
	Low cylinder compression	Section 13 – FE400 Engine
	Spark plug failed	Section 13 – FE400 Engine
	Restricted fuel flow	Section 14 – Fuel System
	Torque converter is not backshifting properly	Section 17 – Torque Converter
<b>Spark plug fouls repeatedly.</b>	Incorrect plug	Section 13 – FE400 Engine
	Unsuitable fuel, or incorrect (rich) fuel mixture	Section 14 – Fuel System
	Spark plug wire is damaged	Section 13 – FE400 Engine
	Dirt entering combustion chamber	Section 14 – Fuel System
<b>Troubleshooting Guide continued on next page...</b>		

<b>TROUBLESHOOTING GUIDE</b>		
<b>SYMPTOM</b>	<b>POSSIBLE CAUSES</b>	<b>REFER TO</b>
<b>Spark plug fouls repeatedly, continued.</b>	Ignition coil failed	Section 11 – Troubleshooting and Electrical System: FE400, Key-Start Engine, Test Procedures 14, 15, and 16
	Rings are heavily worn, low cylinder pressure	See the Engines and Transaxles manual (CC P/N 102396501)
<b>Carburetor floods.</b>	Inlet valve or seat is leaking, dirty, worn, or damaged	Section 14 – Fuel System
	Float is damaged and filled with gasoline	Section 14 – Fuel System
	Carburetor vent is clogged	Section 14 – Fuel System
	Float needle valve not functioning properly	Section 14 – Fuel System
<b>Starter fails to operate.</b>	Lockout cam is in the wrong position	Section 11 – Troubleshooting and Electrical System: FE400, Key-Start Engine, Lockout Cam on page 11-5
	Fuse is blown	Section 11 – Troubleshooting and Electrical System: FE400, Key-Start Engine, Test Procedure 2
	Battery is dead	Section 11 – Troubleshooting and Electrical System: FE400, Key-Start Engine, Test Procedure 1
	Starter control circuit is not operating	Section 11 – Troubleshooting and Electrical System: FE400, Key-Start Engine, Test Procedure 8
	Starter/generator failed	Section 11 – Troubleshooting and Electrical System: FE400, Key-Start Engine, Test Procedure 8
	Starter solenoid failed	Section 11 – Troubleshooting and Electrical System: FE400, Key-Start Engine, Test Procedure 6
	Key switch failed	Section 11 – Troubleshooting and Electrical System: FE400, Key-Start Engine, Test Procedure 4
	Lockout limit switch failed	Section 11 – Troubleshooting and Electrical System: FE400, Key-Start Engine, Test Procedure 7
	Loose or broken wire in starter/generator circuit	Starter/Generator (Model G425419) on page 12-1
	Cylinder and/or crankcase flooded with fuel	Section 14 – Fuel System
<b>Starter/Generator does not charge battery.</b>	Diode failed (open condition)	Section 11 – Troubleshooting and Electrical System: FE400, Key-Start Engine, Test Procedure 10
	Loose or broken wire in the starter/generator circuit	Section 11 – Troubleshooting and Electrical System: FE400, Key-Start Engine, Test Procedure 11
	Generator field coil is shorted	Section 11 – Troubleshooting and Electrical System: FE400, Key-Start Engine, Test Procedure 11
	Brushes are worn or commutator is dirty	Starter/Generator (Model G425419) on page 12-1
<b>Troubleshooting Guide continued on next page...</b>		

<b>TROUBLESHOOTING GUIDE</b>		
<b>SYMPTOM</b>	<b>POSSIBLE CAUSES</b>	<b>REFER TO</b>
<b>Starter/Generator does not charge battery, continued.</b>	Starter/generator belt is loose or slipping	Belt Tension Adjustment on page 12-9
	Voltage regulator failed	Section 11 – Troubleshooting and Electrical System: FE400, Key-Start Engine, Test Procedure 12
	Battery failed	Section 11 – Troubleshooting and Electrical System: FE400, Key-Start Engine, Test Procedure 1
<b>Transmission does not engage or disengage smoothly.</b>	Transmission shifter linkage is binding or is out of adjustment	Forward/Reverse Shifter Cable Adjustment on page 16-25
	Idle RPM Setting is set too high	Section 14 – Fuel System
	Insufficient (low) level of lubricant or wrong type of lubricant in transmission	Lubrication on page 16-2
	Internal gears are damaged or worn	See the Engines and Transaxles manual (CC P/N 102396501)
	Synchronizer rings are worn, damaged or jammed	See the Engines and Transaxles manual (CC P/N 102396501)
<b>Excessive vehicle vibration.</b>	Engine mounting nuts or bolts are loose	Section 13 – FE400 Engine
	Snubber on frame is worn or damaged	Section 13 – FE400 Engine
	Misaligned muffler mounting clamp	Section 15 – Exhaust System
	Damaged drive belt or starter belt	Section 17 – Torque Converter
	Damaged drive clutch	Section 17 – Torque Converter
	Damaged driven clutch	Section 17 – Torque Converter
	Damaged starter/generator pulley	Starter/Generator Removal on page 12-1
	RPM setting is incorrect	Engine RPM Adjustment on page 14-10
<b>Torque converter does not shift smoothly.</b>	Drive belt is worn, cracked, glazed, or frayed	Drive Belt on page 17-3
	Drive clutch malfunction	Drive Clutch Cleaning and Inspection on page 17-5
	Driven clutch malfunction	Drive Clutch Cleaning and Inspection on page 17-5
	Governor is sticking	See the Engines and Transaxles manual (CC P/N 102396501)
<b>Engine won't stop running.</b>	Kill circuit wire is disconnected from the ignition coil	Section 11 – Troubleshooting and Electrical System: FE400, Key-Start Engine, Test Procedure 13
	Key switch failure	Section 11 – Troubleshooting and Electrical System: FE400, Key-Start Engine, Test Procedures 4 and 17
	Carburetor is too lean; check main and pilot jet sizes	Section 14 – Fuel System
	Carburetor throttle stop screw out of adjustment	Section 14 – Fuel System

## ELECTRICAL SYSTEM

---

The electrical system on the FE400 key-start vehicles is 12 volts DC with negative ground to frame. It consists of ten circuits that are easily identified:

- Starter Circuit
- Generator Circuit
- Engine Ignition Circuit
- Engine Kill Circuit
- Reverse Buzzer Circuit
- Low Oil Warning Circuit
- Lockout Cam Circuit
- Fuel Gauge and Sending Unit Circuit
- Hour Meter Circuit
- Lighting Circuit

A key-start vehicle uses the ignition key to activate the electrical system and start the engine. It allows the engine to run at idle or advanced RPM using the accelerator pedal when the Forward/Reverse handle is in the NEUTRAL position. **See Section 13 – FE400 Engine.**

## LOCKOUT CAM

---

This key-start vehicle is equipped with a lockout cam that allows the engine to be started and reved only when the Forward/Reverse handle is in the NEUTRAL position. The lockout cam (yellow) is located on the back of the Forward/Reverse handle, inside the engine compartment.

**NOTE:** Be sure the cam is in the correct position. The cam should activate the limit switch only when the Forward/Reverse handle is in the NEUTRAL position (**Figure 11-1, Page 11-5**).

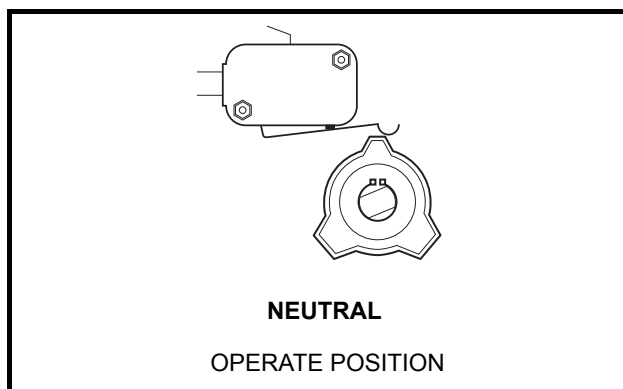


Figure 11-1 Correct Position for Lockout Cam

## CIRCUIT TESTING

---

**See General Warning, Section 1, Page 1-1.**

Test the vehicle battery to determine whether or not it is the source of the problem before testing the electrical circuits. A hydrometer, multimeter and 160-ampere load tester will be required. **See Test Procedure 1 – Battery on page 11-11.**

WIRING DIAGRAMS

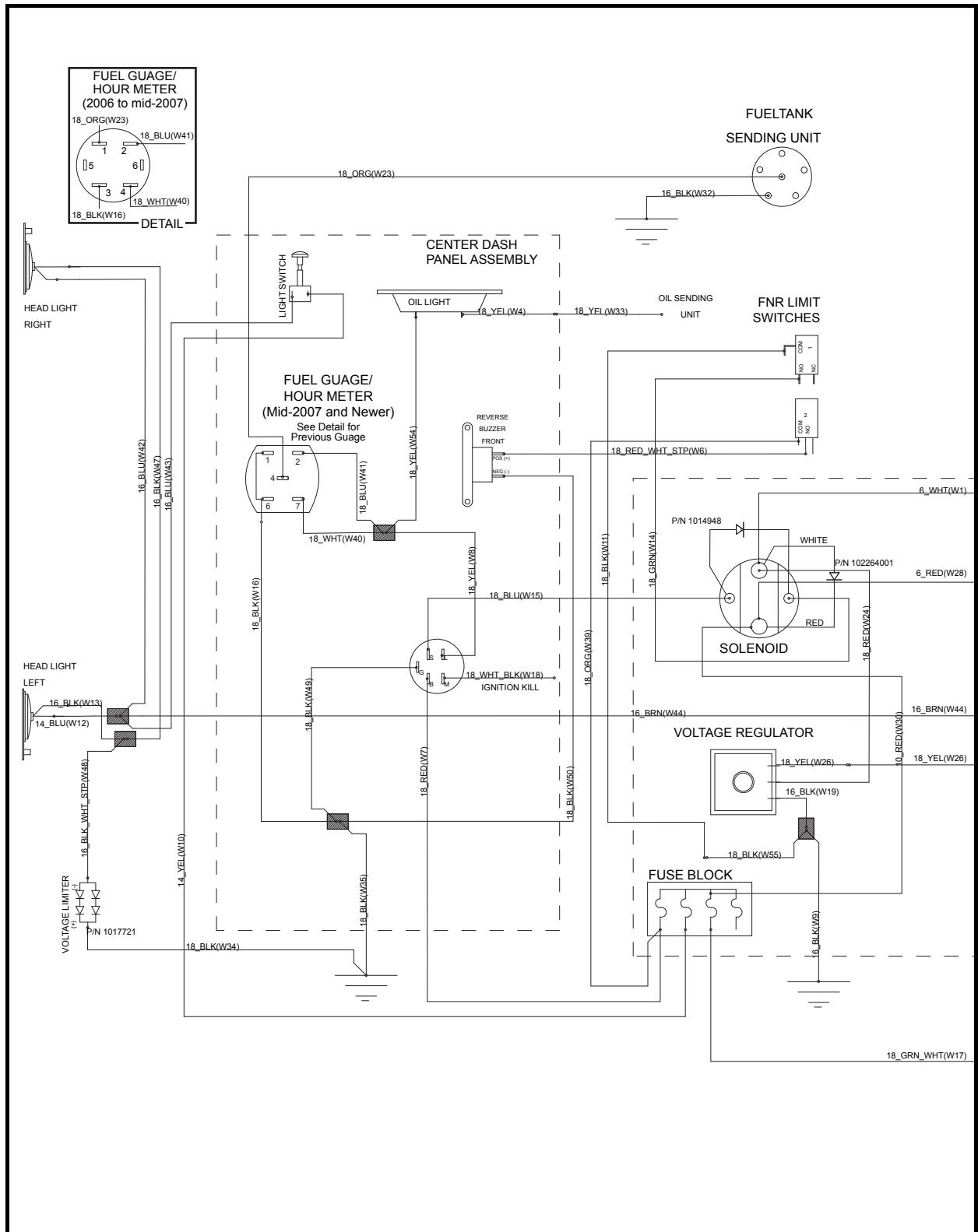


Figure 11-2 Wiring Diagram for FE400 Key-Start 272/1200 Vehicles

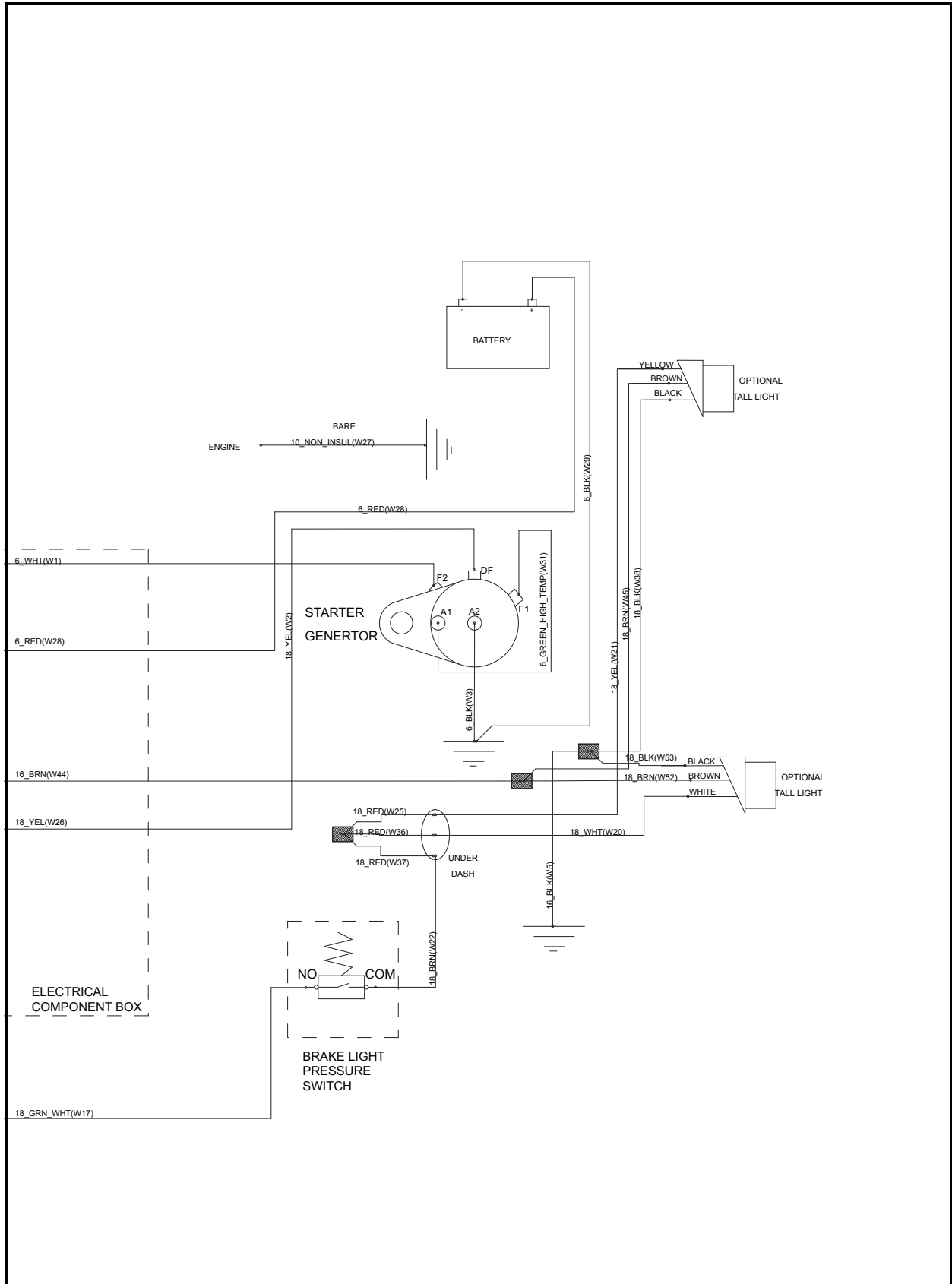


Figure 11-3 Wiring Diagram for FE400 Key-Start 272/1200 Vehicles

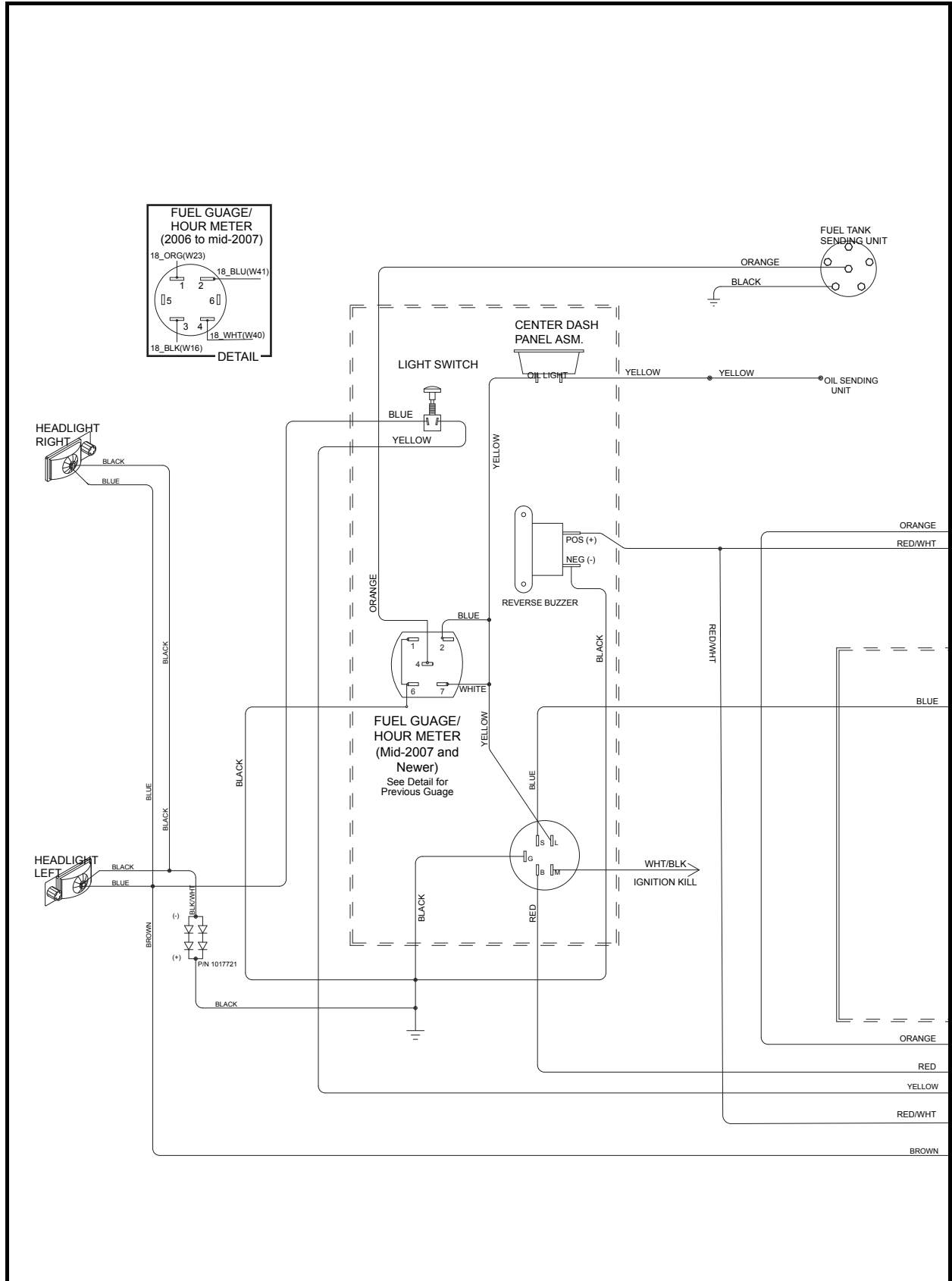


Figure 11-4 Wiring Diagram for FE400 Key-Start 472/1200 SE Vehicles



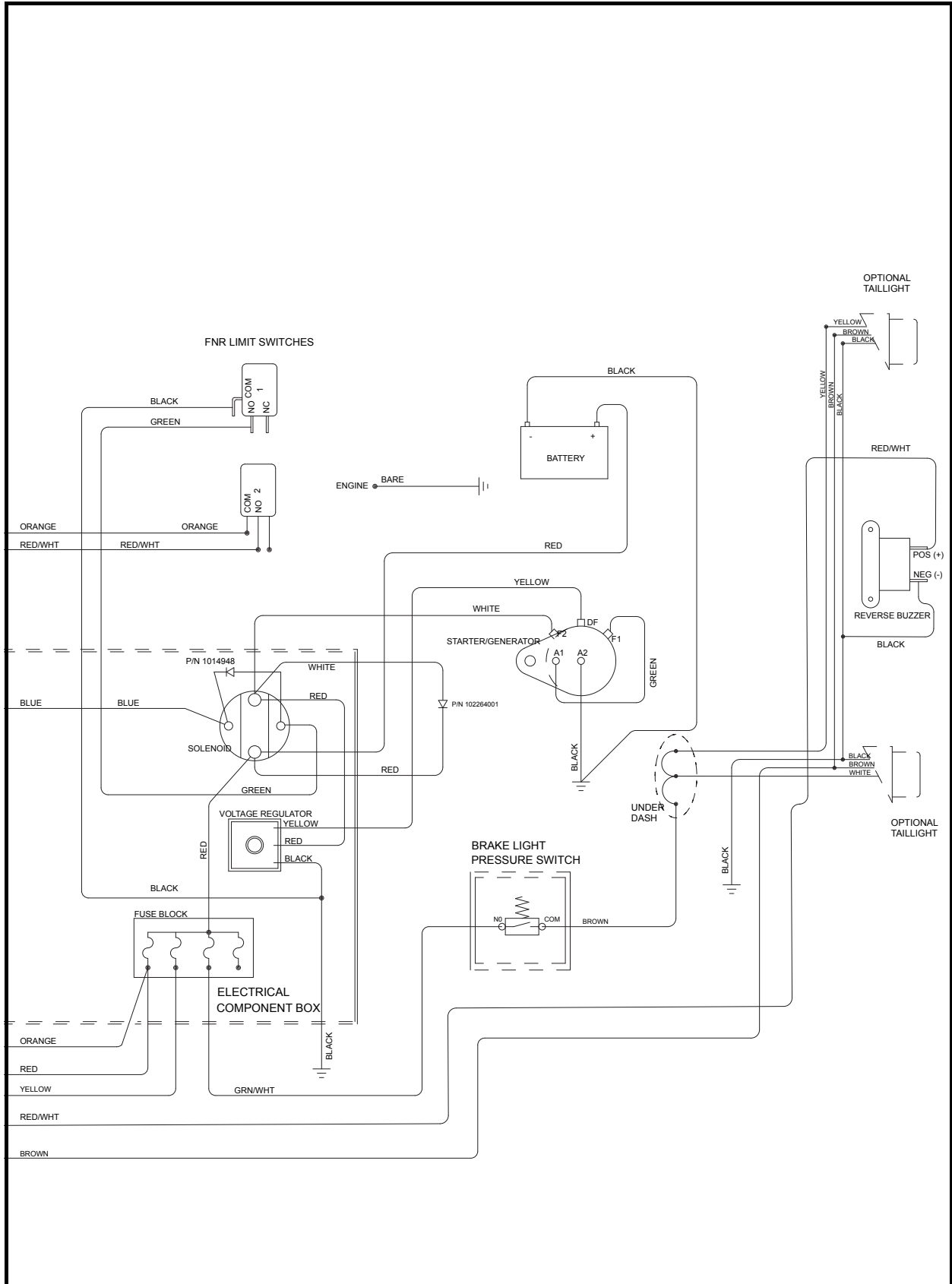


Figure 11-5 Wiring Diagram for FE400 Key-Start 472/1200 SE Vehicles

## TEST PROCEDURES

---

### INDEX OF TEST PROCEDURES

1. Battery
2. Fuse
3. Ground Cables
4. Key Switch (Starter Circuit)
5. Key Switch (Accessory Terminal)
6. Solenoid
7. Lockout Cam Limit Switch
8. Starter/Generator (Starter Function)
9. Wire Continuity
10. Diode (Generator Circuit)
11. Starter/Generator (Generator Function)
12. Voltage Regulator
13. Grounded Kill Wire
14. Ignition Spark
15. RPM Limiter
16. Ignition Coil
17. Key Switch (Engine Kill Circuit)
18. Engine Kill Wire
19. Reverse Buzzer Limit Switch
20. Reverse Buzzer
21. Oil Level Sensor
22. Oil Warning Light
23. Lockout Cam
24. Battery Test (Under Load)
25. Fuel Level Sending Unit
26. Fuel Gauge
27. Hour Meter
28. Light Switch
29. Headlight Diode
30. Voltage at Headlight Socket

## TEST PROCEDURE 1 – BATTERY

See General Warning, Section 1, Page 1-1.

### **⚠ DANGER**

- Due to the danger of an exploding battery, wear a full face shield and rubber gloves when working around a battery.
- **Battery – Explosive gases! Do not smoke. Keep sparks and flames away from the vehicle and service area. Ventilate when charging or using in an enclosed space. Wear a full face shield and rubber gloves when working on or near batteries. For added protection, cover top of the battery when servicing the vehicle.**
- **Battery – Poison! Contains acid! Causes severe burns! Avoid contact with skin, eyes, or clothing.**
  - **External: Flush with water. Call a physician immediately.**
  - **Internal: Drink large quantities of milk or water. Follow with milk of magnesia or vegetable oil. Call a physician immediately.**
  - **Eyes: Flush with water for 15 minutes. Call a physician immediately.**

**NOTE:** The battery must be properly maintained and fully charged in order to perform the following test procedures. Battery maintenance procedures, including watering information and allowable mineral content, can be found in Section 12 of this manual. See **Battery, Section 12, Page 12-39**.

1. Turn the key switch OFF and remove the key. Place the Forward/Reverse handle in the NEUTRAL position. Chock the wheels.
2. Check for loose or corroded battery terminal connections. Clean, tighten and replace connections as necessary.

### **Hydrometer Test**

A hydrometer (CC P/N 1011478) measures the specific gravity. The higher the specific gravity, the higher the state of charge of the battery. A fully charged battery should read between 1.250 and 1.280 at 80 °F (27 °C). Never add acid to the battery to obtain a higher specific gravity (**Figure 11-6, Page 11-12**). See following **CAUTION**.

### **CAUTION**

- **Do not allow battery acid from battery caps or hydrometer to drip onto the body. Battery acid will cause permanent damage. Wash off immediately.**

### **Performing the Hydrometer Test**

1. Be sure that the battery has sufficient water to cover the plates by approximately 1/2-inch (13 mm) and is fully charged prior to beginning the test. If water must be added, recharge the battery before performing the hydrometer test (**Figure 11-7, Page 11-12**).
2. Remove the vent cap.
3. Using a battery thermometer (CC P/N 1011767), record the electrolyte temperature of a center cell.
4. Squeeze the rubber bulb of the hydrometer and insert into the cell. Slowly release the bulb, drawing electrolyte up into the glass tube of the hydrometer.
5. When the float rises off the bottom, adjust the electrolyte level so that the float rides free of the bottom but does not strike the bottom of the rubber bulb. Remove the hydrometer from the cell and release the pressure from the bulb.
6. Hold the hydrometer vertically, ensuring that the float is not contacting the sides of the glass tube. Hold the hydrometer at eye level and read the scale at the level of electrolyte (**Figure 11-6, Page 11-12**).

**Test Procedure 1 – Battery, Continued:**

7. Record the reading.
8. Return the electrolyte to the cell from which it was taken. Replace vent cap.
9. Repeat steps 2 through 8 on all cells.

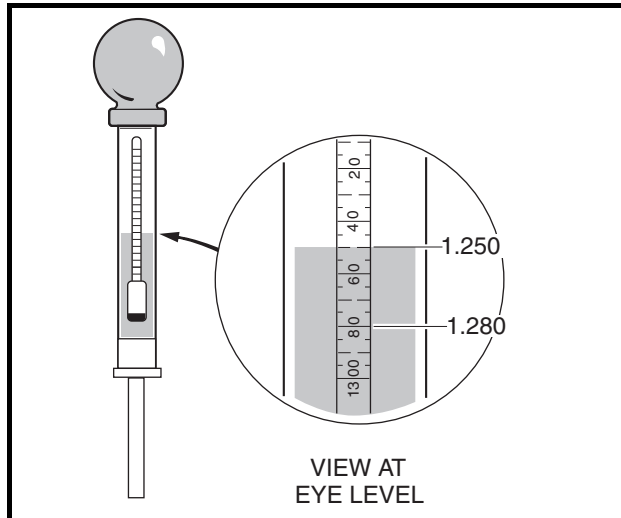


Figure 11-6 Hydrometer Test

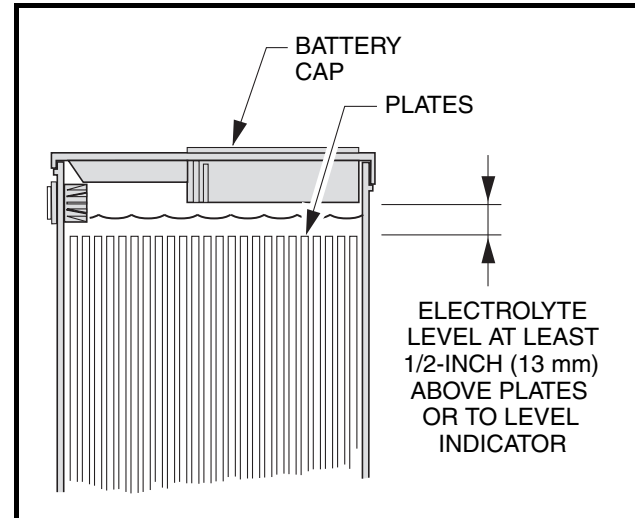


Figure 11-7 Battery Electrolyte Level

**Hydrometer Calibration**

Most hydrometers are calibrated to read correctly at 80 °F (27 °C). The readings obtained as described above must be corrected for temperature. For each 10 °F (5.6 °C) above 80 °F (27 °C), add 0.004 to the reading. For each 10 °F (5.6 °C) below 80 °F (27 °C), subtract 0.004 from the reading.

**Interpreting the Results of the Hydrometer Test**

The approximate state of charge can be determined by referring to the following table:

SPECIFIC GRAVITY (TEMPERATURE CORRECTED)	APPROXIMATE STATE OF CHARGE
1.250-1.280	100%
1.220-1.240	75%
1.190-1.210	50%
1.160-1.180	25%

If the difference between the cells is 0.020 or more, the low cell should be suspected. It may require a catch-up charge or it may be a weak cell. When the variations between cells reach 0.050 or more, the battery should be replaced.

**Voltage Test**

1. Place the red (+) probe of a multimeter set at Volts DC, 20 volt range, on the positive (+) cable and place the black (-) probe on the negative (-) post of the battery and take a voltage reading. If it shows less than 12.4 volts, or if the lowest specific gravity reading from the hydrometer test is less than 1.225, recharge the battery. If battery voltage is greater than 12.4 volts and specific gravity is greater than 1.225, the problem is not with the battery. If the battery does not reach 12.4 volts, or if the specific gravity of a cell is still less than 1.225 after charging, replace the battery. **See following NOTE.**

**NOTE:** A fully charged battery that is in good condition should have a specific gravity of at least 1.225 in all cells, and the difference in the specific gravity of any two cells should be less than 50 points. Open circuit voltage should be at least 12.4 volts.

## Load Test

1. Connect a 160-ampere load tester to the battery posts.
2. Turn the switch on the load tester to the ON position.
3. Read the battery voltage after the load tester has been turned ON for 15 seconds. Compare the battery's voltage reading with the table below. Make sure you have the correct ambient temperature.
4. If the battery is found to be good, or if the electrical problem continues after the battery has been replaced with a good one, test the electrical circuits.

IF TEMPERATURE IS	MINIMUM CRANKING VOLTAGE
70 °F (20 °C) and above	9.6 V
60 °F (16 °C)	9.5 V
50 °F (10 °C)	9.4 V
40 °F (4 °C)	9.3 V
30 °F (-1 °C)	9.1 V
20 °F (-7 °C)	8.9 V
10 °F (-12 °C)	8.7 V
0 °F (-18 °C)	8.5 V

## TEST PROCEDURE 2 – FUSE

**See General Warning, Section 1, Page 1-1.**

The fuse (red 10 amp) is located in the electrical component box.

1. Turn the key switch OFF and remove the key. Place the Forward/Reverse handle in the NEUTRAL position. Chock the wheels.
2. Disconnect battery and spark plug wire(s). **See Disconnecting The Battery on page 1-3.**
3. Remove the cover on the electrical component box.
4. Check that wires are connected correctly and are tight. If they are not, rewire or tighten as necessary.
5. Remove fuse to be tested from the fuse block. **See Fuse Removal, Section 12, Page 12-26.** The red 10 amp fuse protects the solenoid for the starter (cranking) circuit. The 20 amp fuse at the yellow wire connection protects the headlights.
6. Connect the probes of a multimeter set to 200 ohms to the fuse terminals. The reading should be continuity. If there is no continuity, determine and repair the cause of the fuse failure. Replace the fuse with a properly rated new one.

## TEST PROCEDURE 3 – GROUND CABLES

### See General Warning, Section 1, Page 1-1.

1. Turn the key switch OFF and remove the key. Place the Forward/Reverse handle in the NEUTRAL position. Chock the wheels.
2. Disconnect battery and spark plug wire(s). **See Disconnecting The Battery on page 1-3.**
3. Check the starter/generator ground strap.
  - 3.1. Set the multimeter to 200 ohms. Place the red (+) probe on the (A2) terminal of the starter/generator and place the black (-) probe on the vehicle frame (**Figure 11-8, Page 11-14**). The reading should be continuity. If the reading is incorrect, clean and tighten wire connections. If the connections are good and the reading is incorrect, repair or replace the wire.
4. Check the engine ground strap.
  - 4.1. Place the red (+) probe of the multimeter on the ground strap terminal end located on the oil filler bracket on the engine (**Figure 11-9, Page 11-14**). Place the black (-) probe on the vehicle frame. The reading should be continuity. If the reading is incorrect, clean and tighten wire connections. If the connections are good and the reading is incorrect, repair or replace the wire.

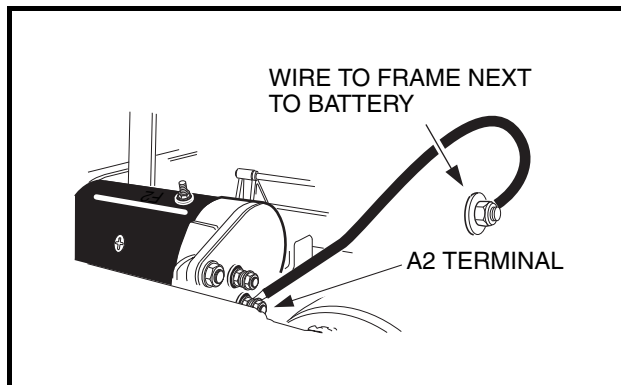


Figure 11-8 Test Starter/Generator Ground Strap

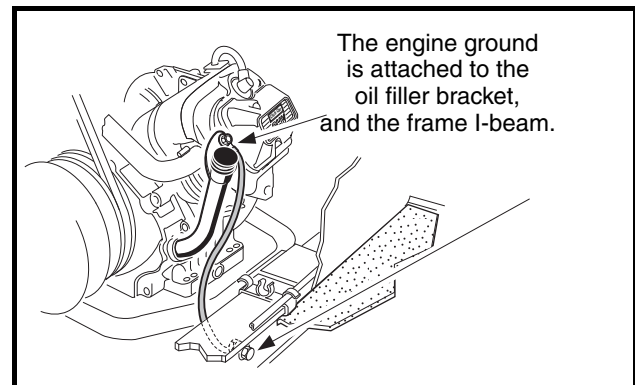


Figure 11-9 Test Engine Ground Strap

5. Check voltage regulator ground connection (at battery frame ground). Make sure it is clean and tight.
6. Check the battery ground cable.
  - 6.1. A 6-gauge black wire connects the negative battery post to the frame. The frame connection should be clean and tight. Visual inspection of the connection on the frame is very difficult. The best check for tightness is to pull on the black wire. If the wire moves at the connection end, disassemble the frame connection and clean the bolt, ring terminal, and nut. Install the frame connection.
  - 6.2. Set the multimeter to 200 ohms. Place the red (+) probe on the unconnected end of the 6-gauge black wire, and place the black (-) probe on the vehicle frame (**Figure 11-10, Page 11-15**). The reading should be continuity. If the reading is incorrect, check that terminal connections are clean and tight. If the connections are good and the reading is incorrect, repair or replace the wire.

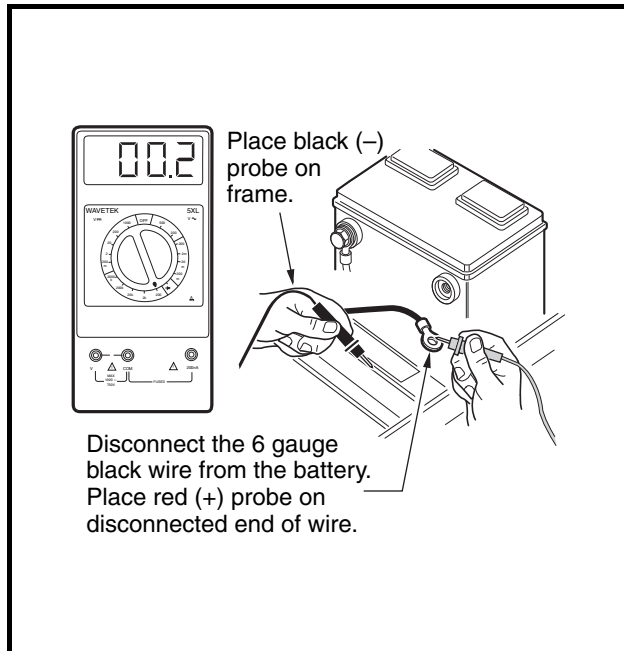


Figure 11-10 Battery Ground Cable Test

## TEST PROCEDURE 4 – KEY SWITCH (STARTER CIRCUIT)

See **General Warning, Section 1, Page 1-1.**

1. Turn the key switch OFF and remove the key. Place the Forward/Reverse handle in the NEUTRAL position. Chock the wheels.
2. Disconnect battery and spark plug wire(s). **See Disconnecting The Battery on page 1-3.**
3. Remove the center dash assembly. **See Key Switch Removal, Section 12, Page 12-24.**
4. Ensure that the connector is connected correctly and is tight. If it is not, repair or replace as necessary.
5. Insert the key and turn the key to ON. Place the red (+) probe of the multimeter on the (B) terminal and the black (-) probe on the (L) terminal of the key switch. The reading should be continuity. If the reading is incorrect, replace the key switch (**Figure 11-11, Page 11-16**). **See Key Switch Removal, Section 12, Page 12-24.**
6. With the key still in the ON position, place the red (+) probe of the multimeter on the (B) terminal and the black (-) probe on the (S) terminal of the key switch. The reading should show no continuity. If the reading is incorrect, replace the key switch. **See Key Switch Removal, Section 12, Page 12-24.** If the reading is correct, leave the probes connected and proceed to the next step.
7. Insert the key and hold the key in the START position. The reading should be continuity. If the reading is incorrect, replace the key switch (**Figure 11-12, Page 11-16**). With the red (+) probe of the multimeter on the (B) terminal and the black (-) probe on the (L) terminal of the key switch, the reading should be continuity. If either reading is incorrect, replace the key switch. **See Key Switch Removal, Section 12, Page 12-24.**

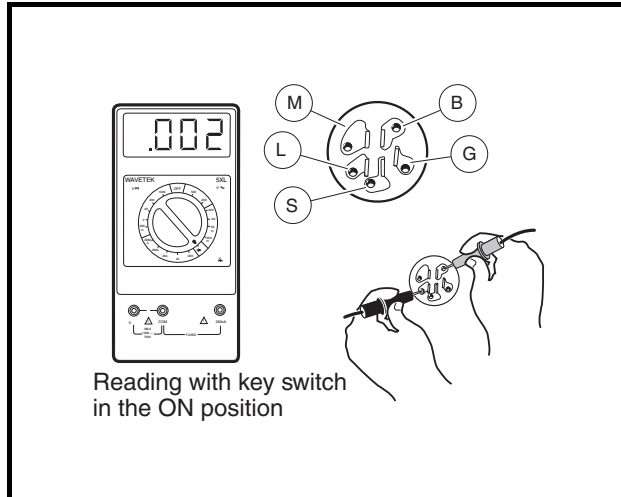


Figure 11-11 Key Switch Test – Accessory Terminal

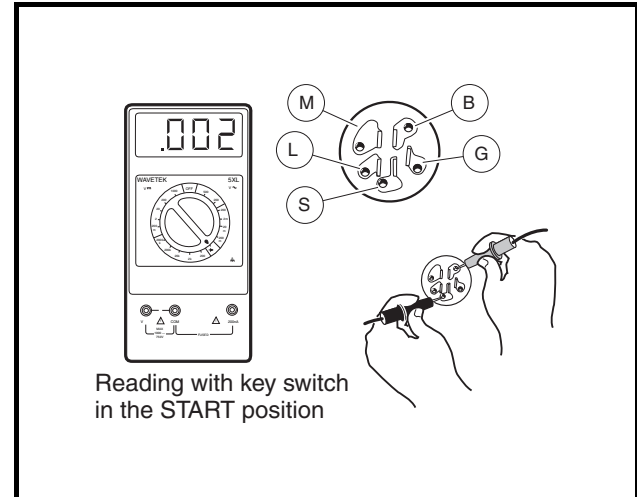


Figure 11-12 Key Switch Test – Starter Circuit

## TEST PROCEDURE 5 – KEY SWITCH (ACCESSORY TERMINAL)

See General Warning, Section 1, Page 1-1.

1. Turn the key switch OFF and remove the key. Place the Forward/Reverse handle in the NEUTRAL position. Chock the wheels.
2. Disconnect battery and spark plug wire(s). See **Disconnecting The Battery** on page 1-3.
3. Remove the center dash assembly. See **Key Switch Removal, Section 12, Page 12-24**.
4. Ensure that the connector is connected correctly and is tight. If it is not, repair or replace as necessary.
5. Insert the key and turn the switch to the ON position. With the multimeter set to 200 ohms, place the red (+) probe of the multimeter on the (B) terminal and the black (–) probe on the (L) terminal of the key switch (**Figure 11-11, Page 11-16**). The reading should be continuity. If the reading is incorrect, replace the key switch. See **Key Switch Removal, Section 12, Page 12-24**.

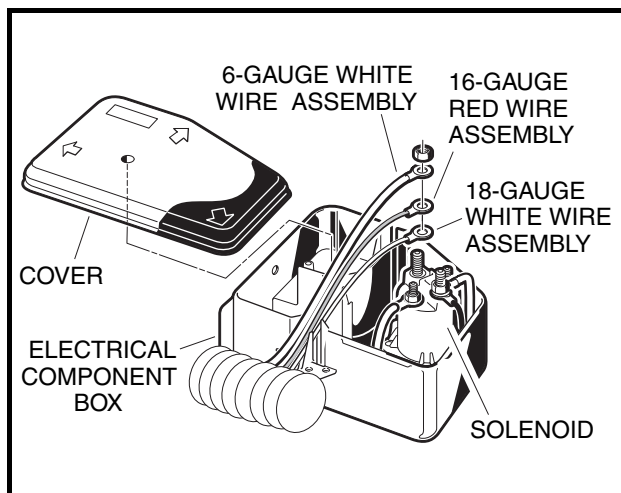


Figure 11-13 Remove Solenoid Wires



## TEST PROCEDURE 6 – SOLENOID

See General Warning, Section 1, Page 1-1.

1. Turn the key switch OFF and remove the key. Place the Forward/Reverse handle in the NEUTRAL position. Chock the wheels.
2. Disconnect battery and spark plug wire(s). **See Disconnecting The Battery on page 1-3.**
3. Remove the electrical component box cover.
4. Check that the wires are connected correctly and are tight. If they are not, rewire or tighten as necessary.
5. Set a multimeter to 200 ohms. Place the red (+) probe on one of the small posts of the solenoid and place the black (–) probe on the other small post. The reading should be 14 to 16 ohms. If the reading is not within limits, replace the solenoid.
6. Remove the 6 and 18-gauge white wires, and the 16-gauge red wire, from the large post of the solenoid. Do not allow the wires to touch the frame or other components of the vehicle (**Figure 11-13, Page 11-16**).
7. Set the multimeter to 200 ohms. Connect the red (+) probe to one of the large posts of the solenoid and connect the black (–) probe to the other large post (**Figure 11-14, Page 11-18**).
8. With the key switch in the OFF position, connect the battery, positive (+) cable first.
9. Place the Forward/Reverse handle in the NEUTRAL position. With the key in the OFF position, the reading on the multimeter should be no continuity. Turn the key switch to the START position and listen for the solenoid click. While holding the key in the START position, there should be continuity. After the key is released, it should rotate to the ON position and should be no continuity. If either reading is incorrect, replace the solenoid.
10. With the Forward/Reverse handle still in the NEUTRAL position, set the multimeter to 20 volts DC and place the red (+) probe on the large post that does *not* have wires connected to it. Place the black (–) probe on the vehicle frame. Turn key switch to the START position and listen for the solenoid click. While holding the key in the START position, the meter should read full battery voltage. If the reading is incorrect, replace the solenoid (**Figure 11-15, Page 11-18**).
11. Disconnect the 6-gauge black wire from the negative post of the battery before reconnecting the wires to the solenoid.
12. Reconnect the solenoid. **See Solenoid Installation, Section 12, Page 12-25. See also following WARNING.**

### **⚠ WARNING**

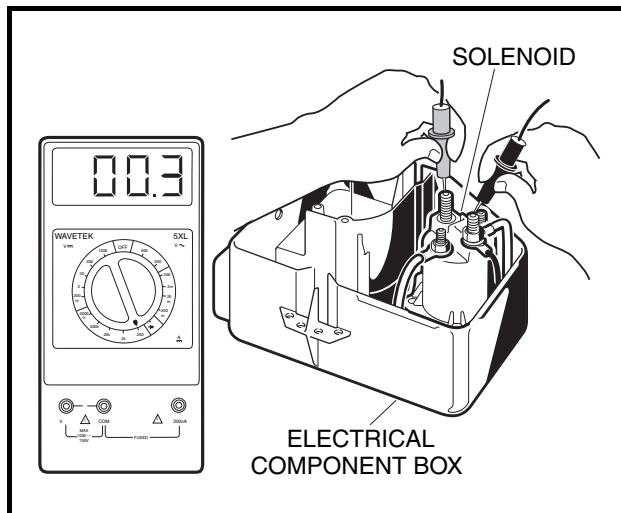
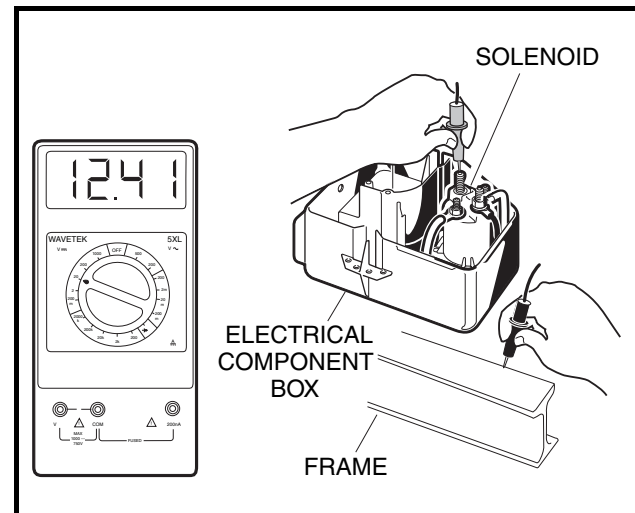
- Incorrect wiring could result in severe injury or death.
- Diode and solenoid connections must have correct polarity.
- Keep all persons clear of engine belts when making final connections.

## TEST PROCEDURE 7 – LOCKOUT CAM LIMIT SWITCH

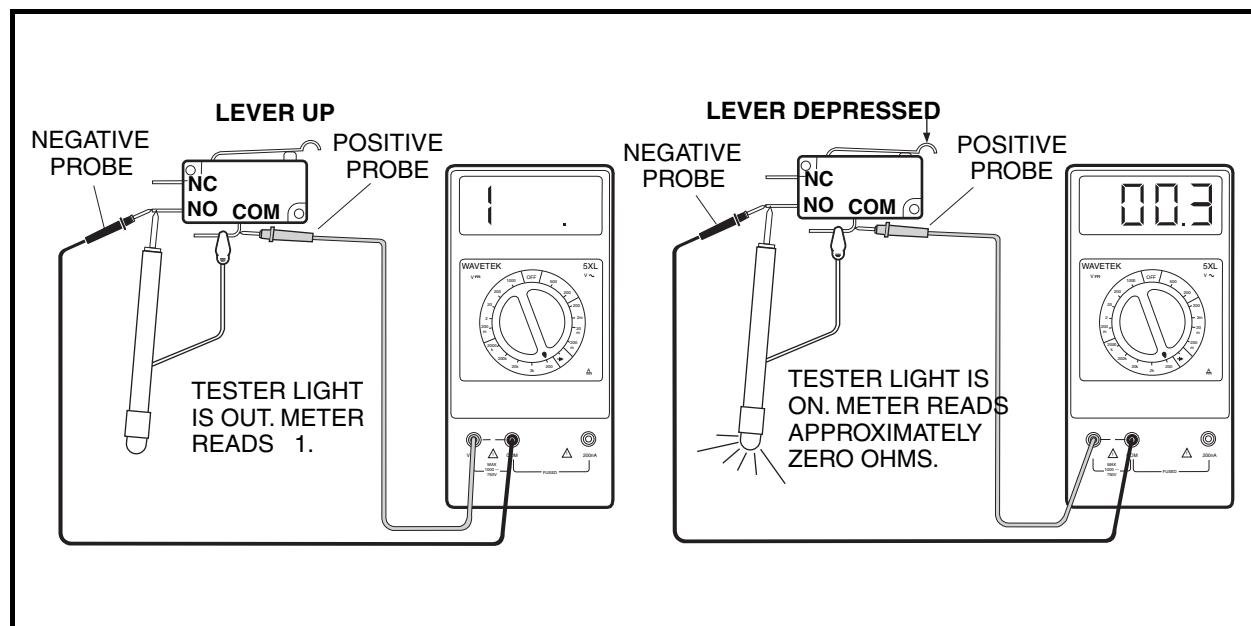
See General Warning, Section 1, Page 1-1.

This limit switch is located on the Forward/Reverse switch assembly. A black wire and a green wire are connected to this limit switch.

1. Turn the key switch OFF and remove the key. Place the Forward/Reverse handle in the NEUTRAL position. Chock the wheels.
2. Disconnect battery and spark plug wire(s). **See Disconnecting The Battery on page 1-3.**
3. Check for proper wiring and tight connections.

**Test Procedure 7 – Lockout Cam Limit Switch, Continued:****Figure 11-14 Test Solenoid Continuity****Figure 11-15 Test Solenoid Ground**

4. Set the multimeter to 200 ohms. Place the red (+) probe of the multimeter on the common (COM) terminal of the limit switch. Place the black (–) probe on the normally open (NO) terminal of the switch. Without the lever pressed, the reading should be no continuity. Press the lever, and the reading should be continuity. If either reading is incorrect, replace the limit switch (**Figure 11-16, Page 11-18**).
5. Check to be sure the lobes on the cam are pressing the lockout cam limit switch when the Forward/Reverse shifter is in the NEUTRAL position only. The limit switch should make an audible click as it is pressed. If it does not, check for wear on the cam lobe. If the cam lobe will not activate the limit switch, replace the cam.

**Figure 11-16 Test Lockout Cam Limit Switch**

## TEST PROCEDURE 8 – STARTER/GENERATOR (STARTER FUNCTION)

### See General Warning, Section 1, Page 1-1.

1. Turn the key switch OFF and remove the key. Place the Forward/Reverse handle in the NEUTRAL position. Chock the wheels.
2. Disconnect battery and spark plug wire(s). **See Disconnecting The Battery on page 1-3.**
3. Check that wires are connected correctly and are tight. If they are not, rewire or tighten as necessary.
4. Disconnect the wires from all the terminals on the starter/generator. Then place the black (–) probe of a multimeter, set to ohms, on the starter/generator housing (scratch through the finish to ensure a good ground). While holding the black probe against the housing, place the red (+) probe (one at a time) on the A1, A2, F1, F2 and DF terminals respectively (**Figure 11-17, Page 11-19**). The readings should be no continuity. If the readings are incorrect, the starter/generator will need to be removed from the vehicle and disassembled by a qualified technician. **See Starter/Generator Removal, Section 12, Page 12-1.**
  - An incorrect reading from the A1 or A2 terminal indicates three possible problems: 1) a grounded A1 or A2 terminal, 2) a grounded wire in the brush area, or 3) a grounded armature/commutator.
  - If the F1 or F2 reading is incorrect, it indicates a possible grounded F1 or F2 terminal or a grounded field coil.
  - If the DF reading is incorrect, it indicates a possible grounded DF terminal or a grounded field coil.
5. Disconnect the ground wire from the A2 terminal and the green wire from the A1 terminal on the starter/generator.
6. Using a multimeter set to 200 ohms, place the red (+) probe on the A1 terminal and the black (–) probe on the A2 terminal. The reading should be continuity. If the reading is incorrect, a possible open or poor contact in a brush assembly and/or open armature windings may be the cause. The starter/generator will need to be removed from the vehicle and disassembled by a qualified technician. **See Starter/Generator Removal, Section 12, Page 12-1.**
7. With the wires still disconnected, using a multimeter set on 200 ohms, place the red (+) probe on the F1 terminal and the black (–) probe on the F2 terminal. The reading should be between approximately 0.1 and 0.3 ohms. If the reading is incorrect, a possible open field coil or bad connections at terminals may be the cause. The starter/generator will need to be removed from the vehicle and disassembled by a qualified technician. **See Starter/Generator Removal, Section 12, Page 12-1.**

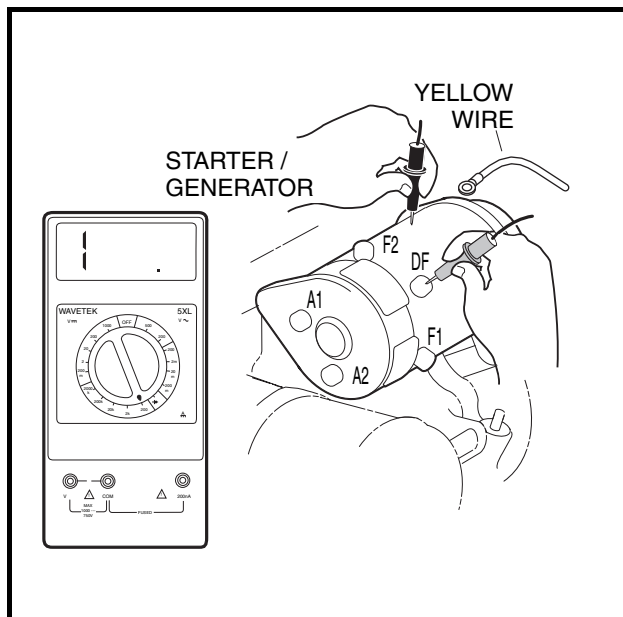


Figure 11-17 Check Starter Terminal Continuity – Model G425419 shown

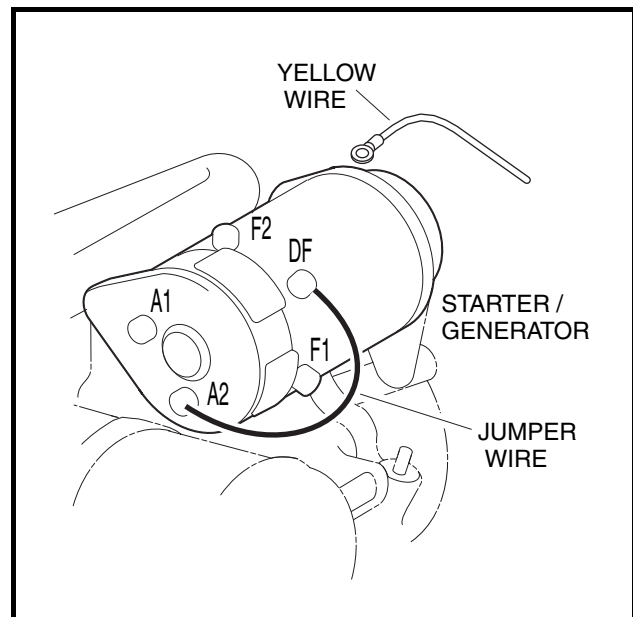


Figure 11-18 Jumper Wire Ground DF to A2 – Model G425419 shown

**Test Procedure 8 – Starter/Generator (Starter Function), Continued:**

8. With the wires still disconnected, using a multimeter set to 200 ohms, place the red (+) probe on the DF terminal and the black (–) probe on the F1 terminal. The reading should be between 4.5 and 5.5 ohms. If the reading is incorrect, a possible grounded DF terminal and/or grounded field coil may be the cause. The starter/generator will need to be removed from the vehicle and disassembled by a qualified technician. **See Starter/Generator Removal, Section 12, Page 12-1.**

**TEST PROCEDURE 9 – WIRE CONTINUITY****See General Warning, Section 1, Page 1-1.**

1. Turn the key switch OFF and remove the key. Place the Forward/Reverse handle in the NEUTRAL position. Chock the wheels.
2. Disconnect battery and spark plug wire(s). **See Disconnecting The Battery on page 1-3.**
3. To test a wire for continuity, disconnect either end from the electrical component it is attached to.
4. Set the multimeter to 200 ohms and place the red (+) probe on the terminal at one end of the wire. Place the black (–) probe on the other terminal end of the wire. The reading should be continuity. If the reading is incorrect, repair or replace the wire.

**TEST PROCEDURE 10 – DIODE (GENERATOR CIRCUIT)****See General Warning, Section 1, Page 1-1.**

1. Turn the key switch OFF and remove the key. Place the Forward/Reverse handle in the NEUTRAL position. Chock the wheels.
2. Disconnect battery and spark plug wire(s). **See Disconnecting The Battery on page 1-3.**
3. Disconnect the red and white wires of the diode assembly from the solenoid posts, located within the electrical component box.
  - 3.1. Remove the intake hose to the carburetor at the carburetor intake port and move the hose to allow easy access to the electrical component box cover.
  - 3.2. Remove the cover retaining screw (5) and electrical component box cover (6) (**Figure 11-19, Page 11-21**).
  - 3.3. Remove the locknuts (7) from the two large solenoid posts and disconnect the diode wires from the solenoid.
4. With the multimeter set to the diode test function (→←), connect the black (–) probe of the multimeter to the white lead of the diode and the red (+) probe of the multimeter to the red lead of the diode (**Figure 11-20, Page 11-21**). The reading should indicate an overload (no continuity). A diode is designed to conduct current in one direction only. If a diode conducts current (shows continuity) with the meter probes as described, the diode has failed and must be replaced. **See Diode Removal, Section 12, Page 12-22.**
5. Reverse the multimeter probes and note the reading. With the black (–) probe of the multimeter to the red lead of the diode and the red (+) probe of the multimeter to the white lead, the meter should read approximately 450 mV, however, a range of 400-500 mV is acceptable (**Figure 11-21, Page 11-21**).
6. Connect either the black (–) or red (+) lead of the multimeter to the diode body (case). Connect the other multimeter lead to both the red and white lead terminals of the diode. The multimeter should indicate an overload, (no continuity). If continuity reading does occur, it indicates that one or both of the diode leads are grounded to the diode body (case) and the diode must be replaced. **See Diode Removal, Section 12, Page 12-22.**
7. If the diode tests good, reconnect the diode leads. **See Diode Installation, Section 12, Page 12-22. See also following WARNING.**

**⚠ WARNING**

- Incorrect wiring could result in severe injury or death.
- Diode and solenoid connections must have correct polarity.
- Keep all persons clear of engine belts when making final connections.

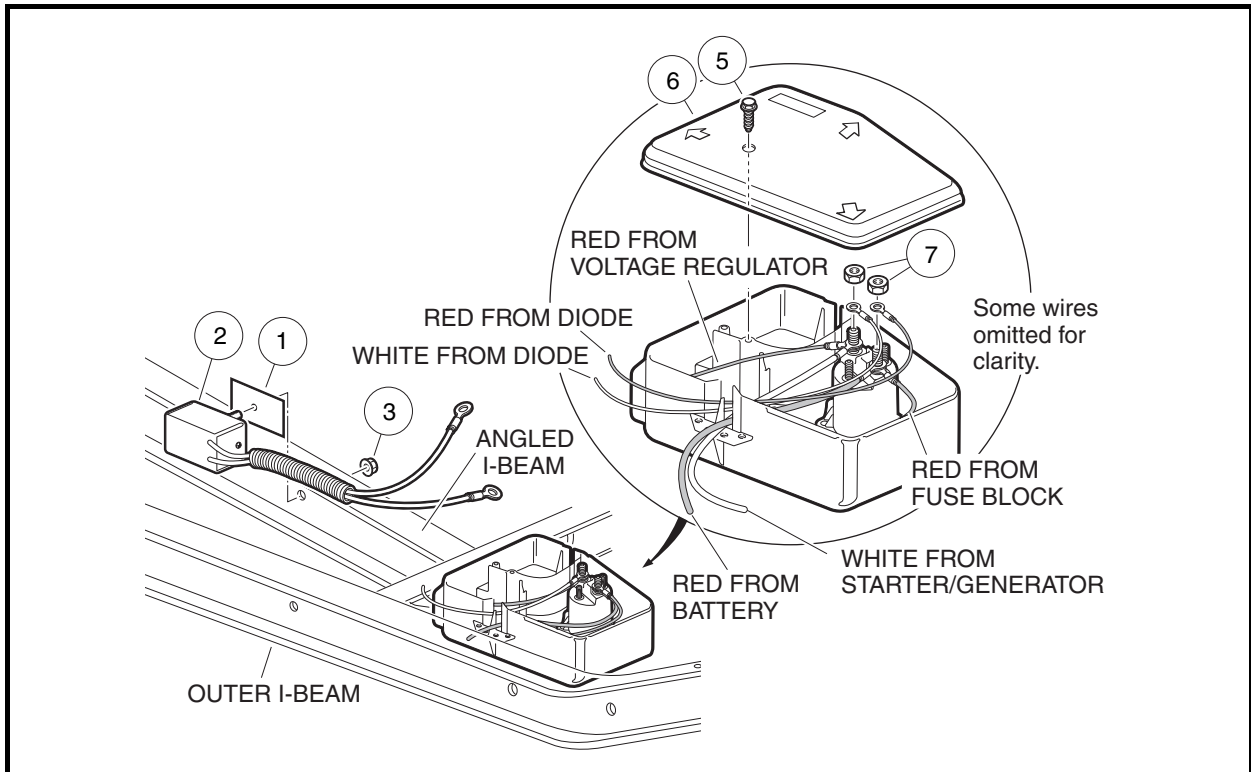


Figure 11-19 Electrical Control Box and Diode Orientation

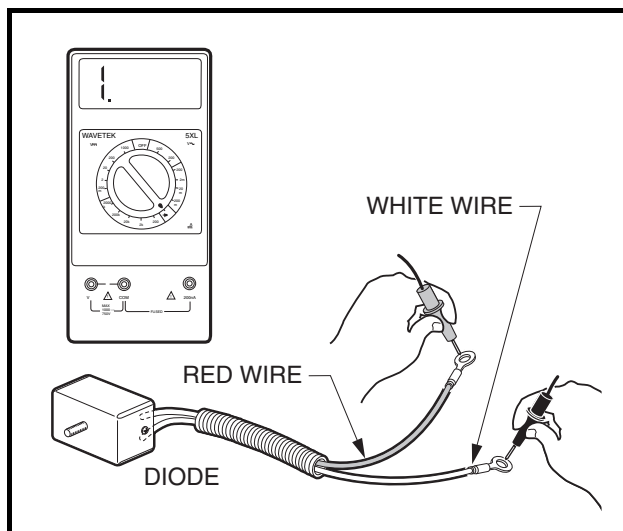


Figure 11-20 Diode Test

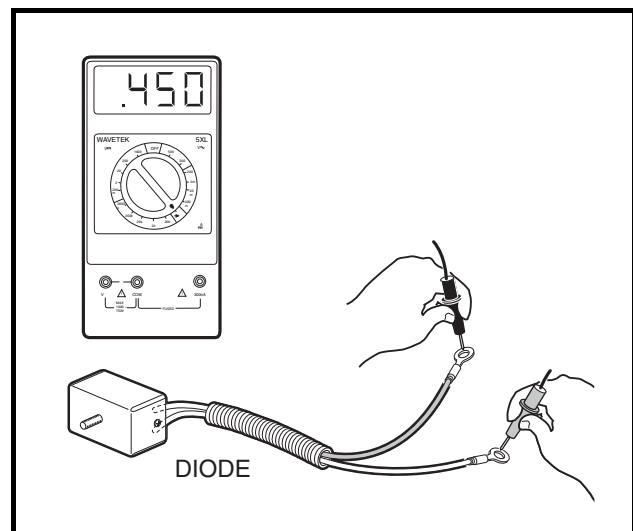


Figure 11-21 Diode Test – Probes Reversed

## TEST PROCEDURE 11 – STARTER/GENERATOR (GENERATOR FUNCTION)

See General Warning, Section 1, Page 1-1.

**NOTE:** Perform Test Procedure 10 before proceeding with this test procedure.

*Keep the battery connected while performing this test procedure.*

1. Turn the key switch OFF and remove the key. Place the Forward/Reverse handle in the NEUTRAL position. Chock the wheels.
2. Ensure that the wires are connected correctly and are tight. If they are not, rewire or tighten as necessary.
3. Disconnect the yellow wire from the DF terminal on the starter/generator. Cover the connector on the yellow wire to make sure the yellow wire will not short to ground. Then, using a jumper wire, ground the DF terminal to the A2 terminal (**Figure 11-18, Page 11-19**).
4. Using a multimeter set to 20 volts DC, place the red (+) probe on the positive (+) cable of the battery, and place the black (–) probe on the negative (–) post. Start the engine and run it at full governed speed. The reading should show the voltage rising on the meter. If the voltage rises, see Test Procedure 12 – Voltage Regulator on page 11-22. If the voltage does not rise, and the diode was found to be functioning properly in Test Procedure 10, a tear-down inspection of the starter/generator will be necessary. **See Starter/Generator Removal, Section 12, Page 12-1.**
5. Reconnect the yellow wire to the DF terminal on the starter/generator.

## TEST PROCEDURE 12 – VOLTAGE REGULATOR

See General Warning, Section 1, Page 1-1.

**NOTE:** Perform Test Procedures 10 and 11 before proceeding with this test procedure.

*Keep the battery connected while performing this test procedure.*

1. Turn the key switch OFF and remove the key. Place the Forward/Reverse handle in the NEUTRAL position. Chock the wheels.
2. Check that the wires are connected correctly and are tight. If they are not, rewire or tighten as necessary.
3. Check the engine RPM setting to ensure that it is adjusted correctly. **See Engine RPM Adjustment, Section 14, Page 14-10.**
4. With the battery in good condition and fully charged, run the engine for several minutes to bring the voltage regulator to operating temperature.
5. Turn the key switch to the OFF position, killing the engine. Using a multimeter set to 20 volts DC, place the red (+) probe on the large post of the solenoid with the red wire from the voltage regulator attached. Place the black (–) probe on the negative (–) battery post (**Figure 11-22, Page 11-23**). With the Forward/Reverse handle in the NEUTRAL position and the wheels chocked, turn the key switch to the START position to start the engine. Press the accelerator to run the engine at full governed speed. If the reading is between 14.7 and 15.3 volts, the regulator is good. If the reading is lower than 14.7 volts but rising steadily, check battery condition. **See Hydrometer Test on page 11-11.** If the reading is lower than 14.7 volts and not rising, and the starter/generator is good; or if the reading is over 15.3 volts and continues to rise, replace voltage regulator. **See Voltage Regulator Removal, Section 12, Page 12-21.**

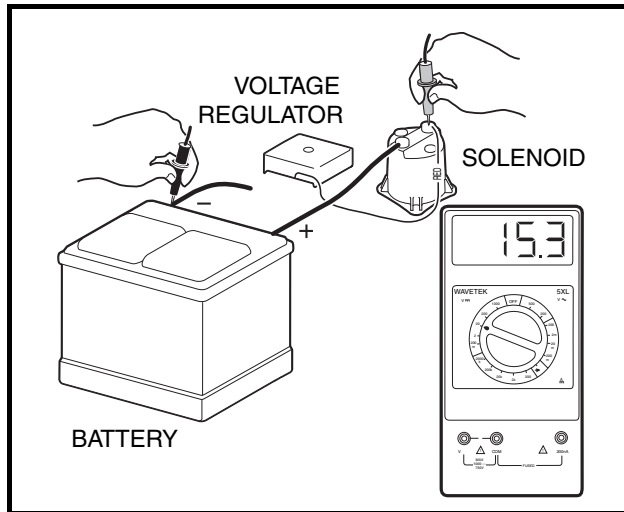


Figure 11-22 Test Voltage Regulator

### TEST PROCEDURE 13 – GROUNDED KILL WIRE

See General Warning, Section 1, Page 1-1.

**NOTE:** Keep the battery connected while performing this test procedure.

1. Turn the key switch OFF and remove the key. Place the Forward/Reverse handle in the NEUTRAL position. Chock the wheels.
2. Disconnect the engine-kill white/black wire at the bullet connector located next to the RPM limiter (Figure 11-24, Page 11-24).

**NOTE:** Disconnecting the engine-kill wire removes it from the start/stop circuit.

3. Turn the key switch to the START position and release after the engine starts. If the engine starts and continues to idle, check the kill-wire for grounding, the kill limit switch, and the key switch. See Test Procedure 18 – Engine Kill Wire on page 11-31. See following WARNING.

#### **⚠ WARNING**

- When the white/black engine kill wire is disconnected, the engine will not stop running after the key switch is turned to the OFF position. It will be necessary to pull and hold the choke handle until the engine stops running.
4. If the engine does not run, connect the white/black wire at the bullet connector next to the RPM limiter and proceed to Test Procedure 14 – Ignition Spark on page 11-23.

### TEST PROCEDURE 14 – IGNITION SPARK

See General Warning, Section 1, Page 1-1.

**NOTE:** Keep the battery connected while performing this test procedure.

1. Turn the key switch OFF and remove the key. Place the Forward/Reverse handle in the NEUTRAL position. Chock the wheels.
2. Remove the plug wire from the spark plug. Using an ignition spark gap test tool (Thexton 404<sup>®</sup> or equivalent), check for correct spark (Figure 11-23, Page 11-24).

**Test Procedure 14 – Ignition Spark, Continued:**

- 2.1. Adjust the tester probes to approximately to 18,000 volts (18 Kv) setting (SE – *Small Engine Setting* on the Thexton 404 tool). Connect the tester to the spark plug wire, and connect the alligator clip to a solid engine ground.
- 2.2. Start the engine. There should be a strong blue spark between the probes of the spark gap tester. If there is no spark, or if the spark is a faint yellow or red color, test components of the ignition circuit.
3. If the spark gap tester tool indicates a strong blue spark, it is possible the spark plug has failed internally. Check the spark plug gap. The gap should be set at 0.027 to 0.031 of an inch (0.69 to 0.79 mm). If the gap is correct, replace the spark plug with a new part and test the engine for proper operation.

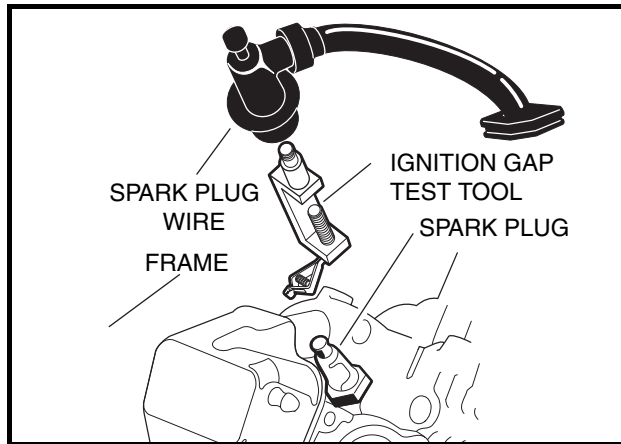


Figure 11-23 Ignition Spark Test

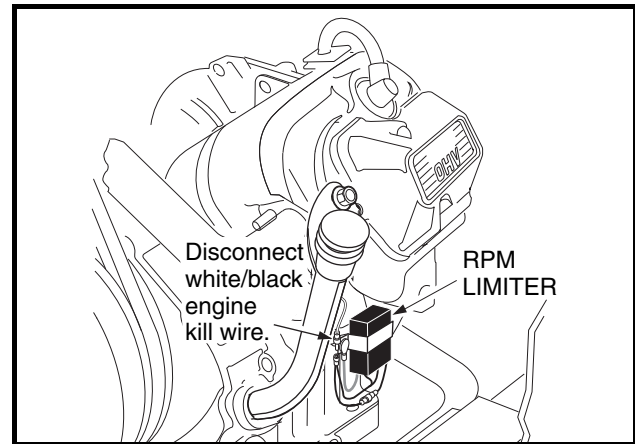


Figure 11-24 Disconnect White/Black Engine Kill Wire

**TEST PROCEDURE 15 – RPM LIMITER****See General Warning, Section 1, Page 1-1.**

1. Turn the key switch OFF and remove the key. Place the Forward/Reverse handle in the NEUTRAL position. Chock the wheels.
2. Disconnect battery and spark plug wire(s). **See Disconnecting The Battery on page 1-3.**
3. Disconnect both of the bullet terminals (**Figure 11-25, Page 11-25**).
4. Using a multimeter set to 200 ohms, place the red (+) probe on the brown ground wire and place the black (-) probe on one of the black wire female bullet connectors. The reading should be no continuity. If the reading is not correct, replace the RPM limiter.
5. This test will find most bad RPM limiters. Some of them may bench test okay but fail under a load due to heat while operating. Another method of testing is to replace the RPM limiter and then run the engine. If the engine runs properly, keep the new RPM limiter in the circuit.

**TEST PROCEDURE 16 – IGNITION COIL****See General Warning, Section 1, Page 1-1.**

The following test procedures will properly detect a coil that has failed in most cases; however, in rare cases, some ignition coils can fail to operate at normal (warmer) operating temperatures. If the ignition coil has tested okay in the vehicle and on the bench, but fails to operate reliably, replace the coil with a known good coil and operate the engine for several minutes to ensure that the coil functions at normal operating temperature. If the new coil functions properly, keep the new coil in the circuit.



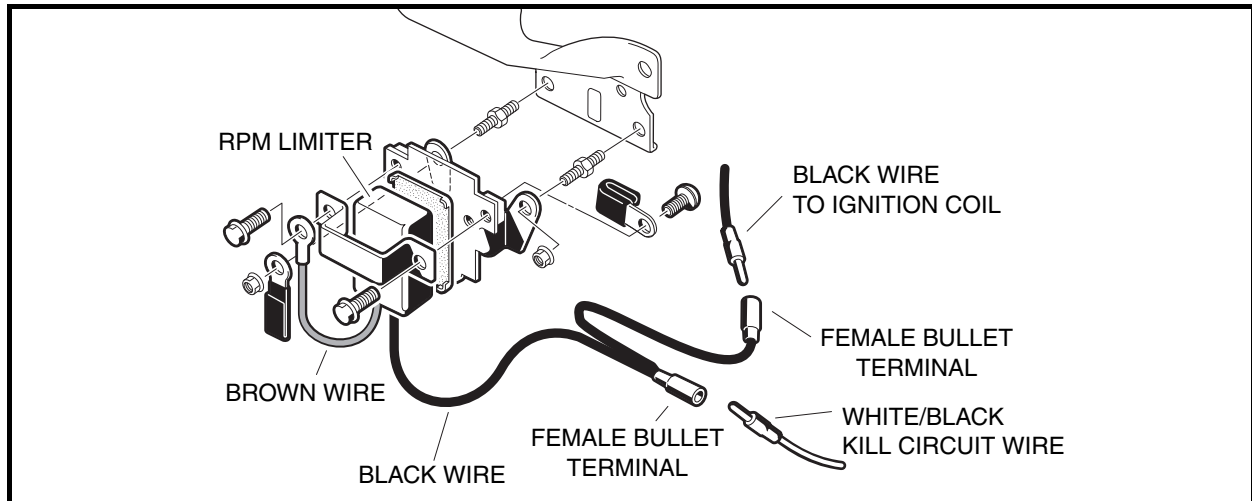


Figure 11-25 RPM Limiter

### Ignition Coil – In Vehicle Test

1. Turn the key switch OFF and remove the key. Place the Forward/Reverse handle in the NEUTRAL position. Chock the wheels.
2. Disconnect battery and spark plug wire(s). **See Disconnecting The Battery on page 1-3.**
3. Using a multimeter set to 200 ohms, measure the primary coil resistance.
  - 3.1. Disconnect both of the bullet terminals at the RPM limiter (**Figure 11-25, Page 11-25**). Place the red (+) probe of the meter on the male bullet terminal of the wire connecting to the ignition coil under the fan housing, and place the black (-) probe on a clean unpainted surface of the engine or frame (**Figure 11-26, Page 11-25**).
  - 3.2. If the resistance is not between 0.6 - 1.7 ohms, bench test the ignition coil. **See Ignition Coil – Bench Test on page 11-28.**

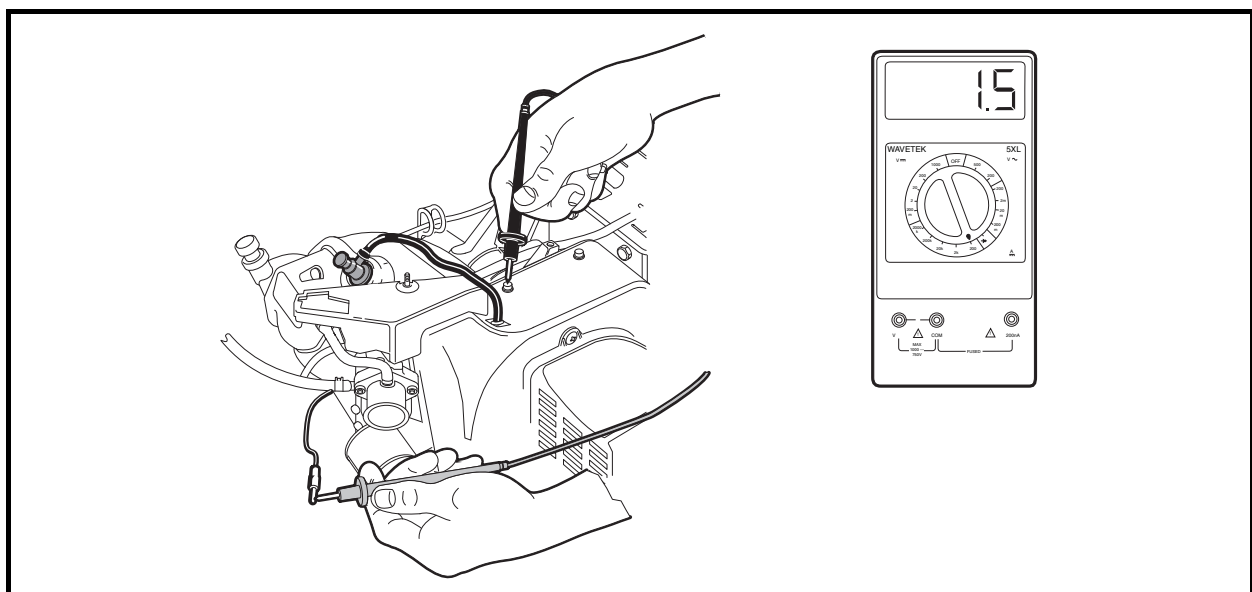
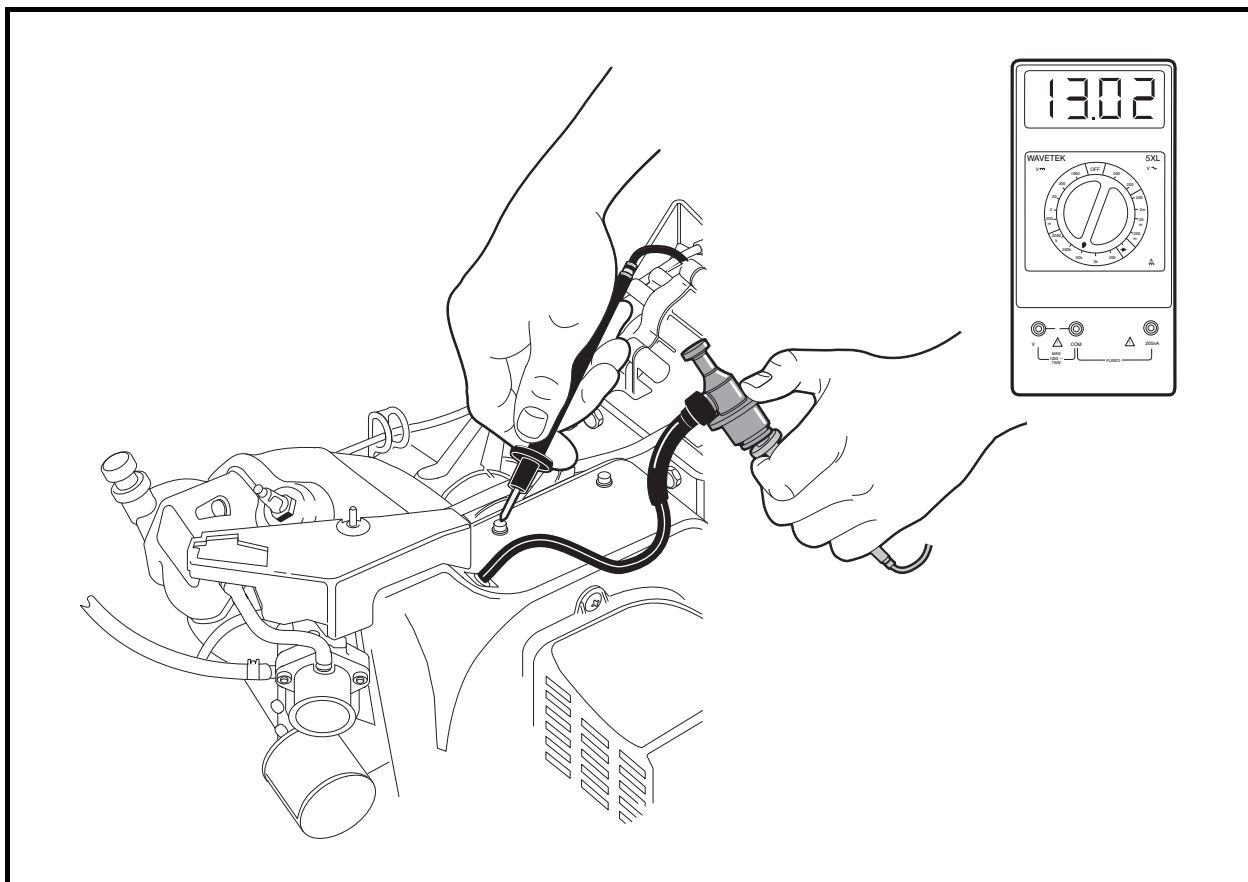


Figure 11-26 Primary Coil Resistance – In Vehicle Test

**Test Procedure 16 – Ignition Coil, Continued:**

4. Using a multimeter set to 20k ohms, measure the resistance of the secondary coil and spark plug cap together.
  - 4.1. Place the red (+) probe of the meter into the end of the spark plug cap that normally connects to the spark plug and place the black (–) probe on a clean unpainted surface of the engine or frame (**Figure 11-27, Page 11-26**).
  - 4.2. If the resistance is between 12.0k - 14.0k ohms, the secondary coil and spark plug cap are within acceptable limits; proceed to step 7 on page 11-27. If the resistance is not between 12.0k - 14.0k ohms, the spark plug cap and secondary coil must be tested independently from each other.
5. Test the spark plug cap separately from the secondary coil.
  - 5.1. Remove the rubber gasket (1) on the plug cap (2) by rolling back the gasket onto the spark plug wire (3) (**Figure 11-28, Page 11-27**).
  - 5.2. Remove the cap from the wire by turning the cap counterclockwise three or four revolutions while gently pulling it off the wire (**Figure 11-29, Page 11-27**).
  - 5.3. Using a multimeter set to 20k ohms, place the red (+) probe of the multimeter into the end of the spark plug cap that normally connects to the spark plug and place the black (–) probe into the end of the cap with the internal screw (**Figure 11-30, Page 11-27**). If the resistance is not between 4.5k - 6.0k ohms, the cap has failed and must be replaced. Proceed to the next step with the spark plug cap still removed.

**Figure 11-27 Secondary Coil Test – In Vehicle Test**

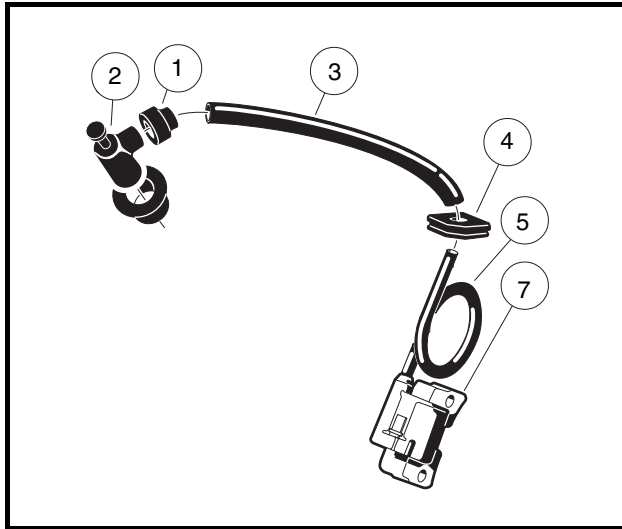


Figure 11-28 Ignition Coil and Cap

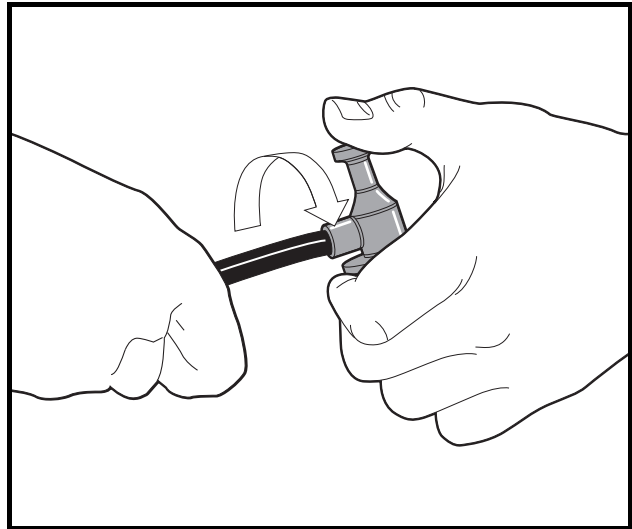


Figure 11-29 Spark Plug Cap Removal

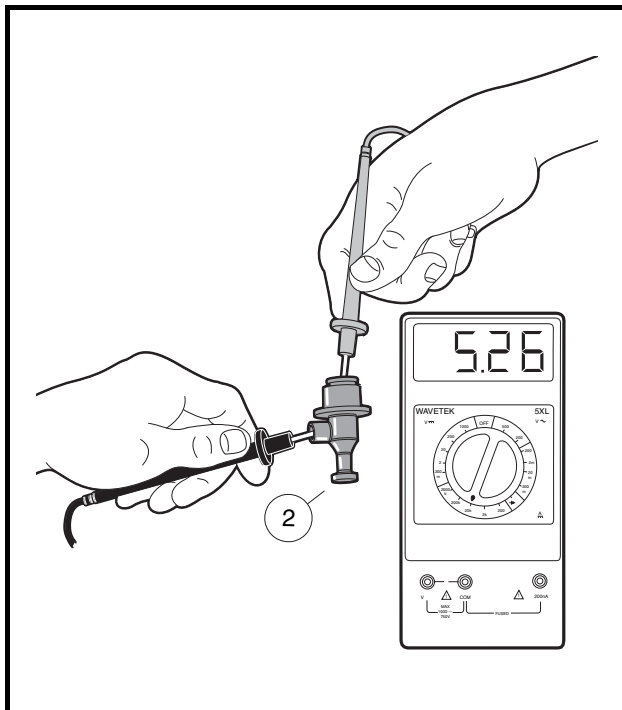


Figure 11-30 Spark Plug Cap Test

6. Test the secondary coil separately from the spark plug cap.
  - 6.1. Using a multimeter set to 20k ohms, place the red (+) probe of the meter into the end of the spark plug wire and place the black (-) probe on a clean unpainted surface of the engine or frame (**Figure 11-31, Page 11-28**). If the resistance is between 6.0k - 11.0k ohms, the secondary coil is within acceptable limits. If the resistance is not between 6.0k - 11.0k ohms, bench test the ignition coil.
7. If the preceding procedures indicate that the ignition coil resistance readings are within acceptable ranges, but the coil fails to function properly, proceed to the following bench test procedures.

## Ignition Coil – Bench Test

1. Remove the coil from the engine. **See Ignition Coil Removal, Section 12, Page 12-34.**
2. Using a multimeter set to 200 ohms, measure the primary coil resistance.
  - 2.1. Place the black (–) probe of the meter on the terminal on the ignition coil (1), and place the red (+) probe on the core (2) (**Figure 11-32, Page 11-29**).
  - 2.2. If the resistance is not between 0.6 - 1.7 ohms, replace the ignition coil.
3. Using a multimeter set to 20k ohms, measure the resistance of the secondary coil and spark plug cap together.
  - 3.1. Place the red (+) probe of the meter into the end of the spark plug cap that normally connects to the spark plug (3) and place the black (–) probe on the core (2) (**Figure 11-33, Page 11-29**).
  - 3.2. If the resistance is between 12.0k - 14.0k ohms, the secondary coil and spark plug cap are within acceptable limits; proceed to step 6 on page 11-30. If the resistance is not between 12.0k - 14.0k ohms, the spark plug cap and secondary coil must be tested independently from each other.

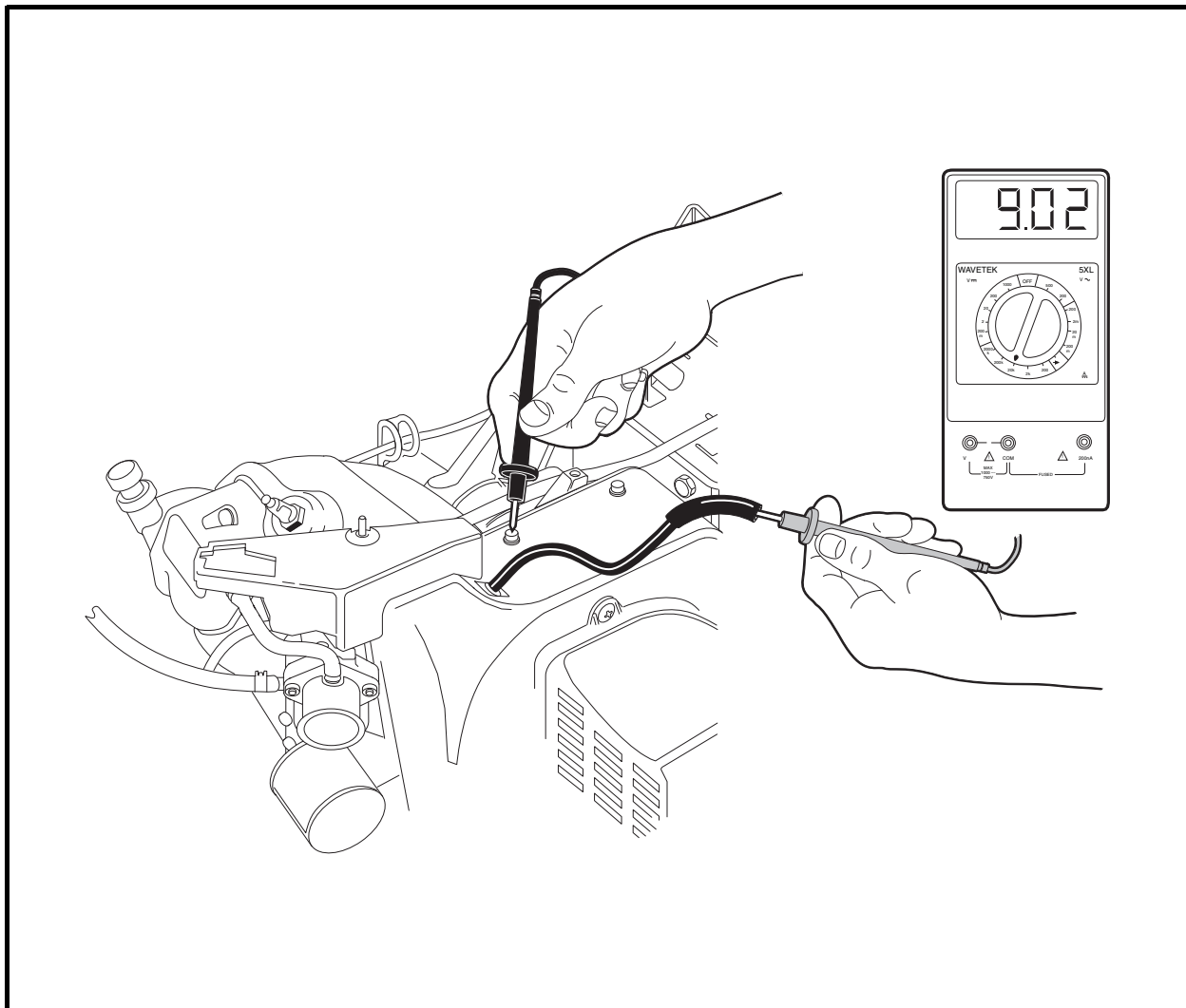


Figure 11-31 Secondary Coil Test Without Cap

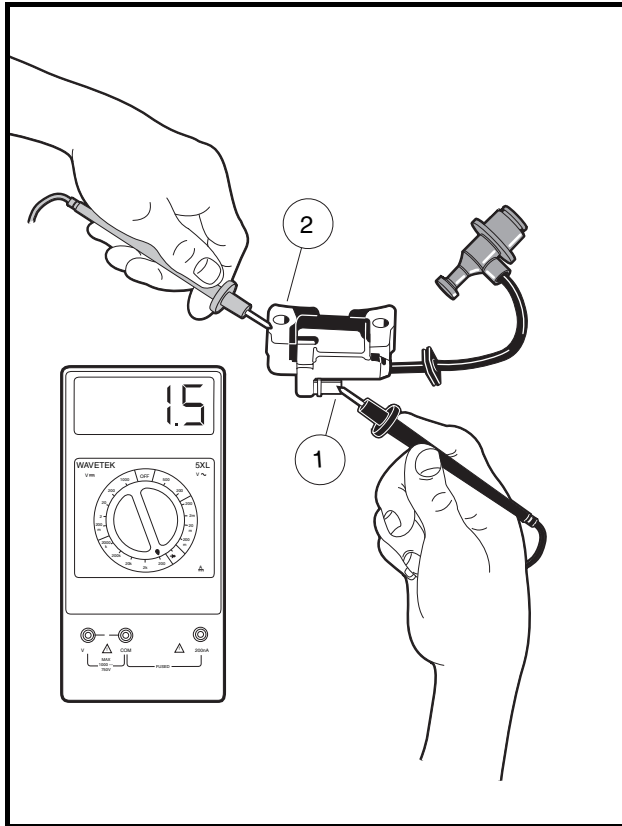


Figure 11-32 Primary Coil Resistance – Bench Test

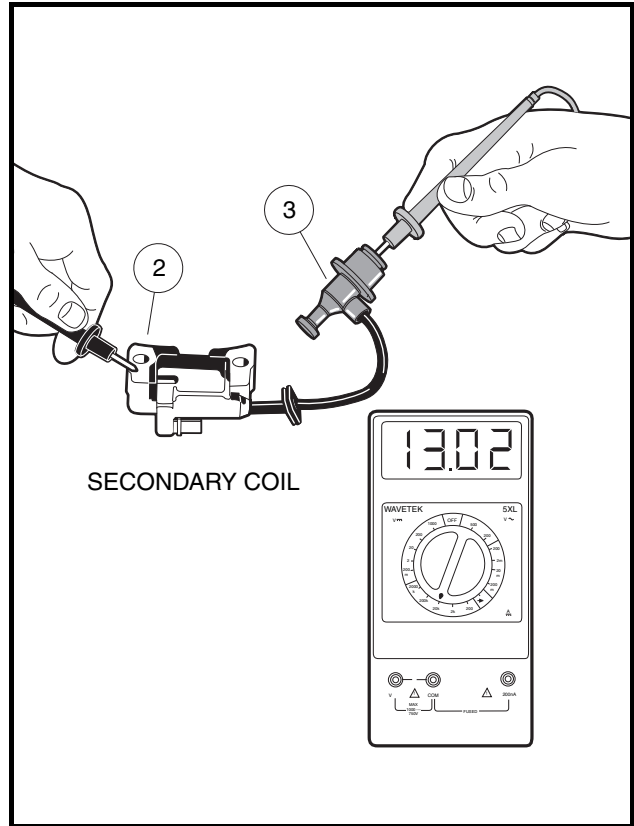


Figure 11-33 Secondary Coil and Cap Resistance – Bench Test

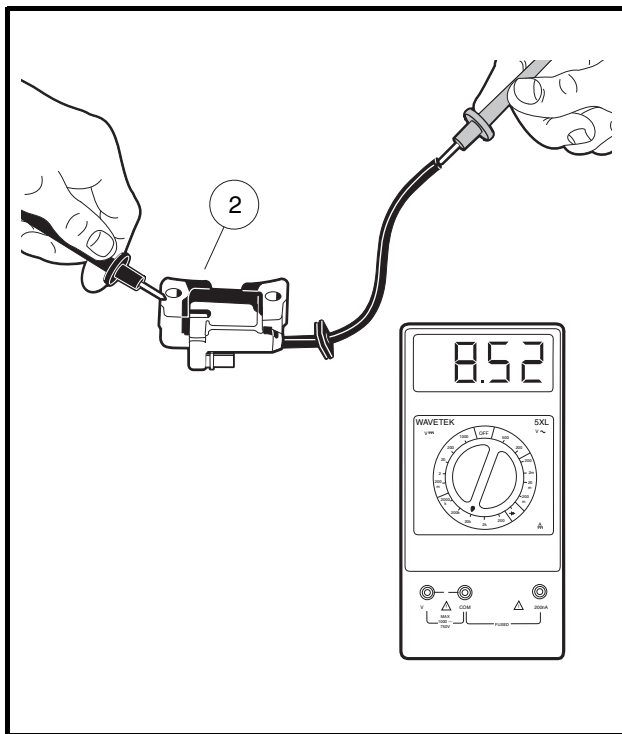


Figure 11-34 Secondary Coil Resistance – Bench Test

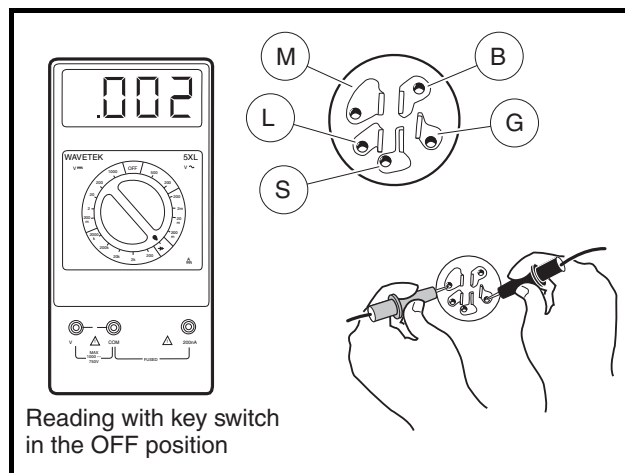
**Test Procedure 16 – Ignition Coil, Continued:**

4. If not previously tested, test the spark plug cap separately from the secondary coil.
  - 4.1. Remove the rubber gasket (1) on the plug cap (2) by rolling back the gasket onto the spark plug wire (3) (**Figure 11-28, Page 11-27**).
  - 4.2. Remove the cap from the wire by turning the cap counterclockwise three or four revolutions while gently pulling it off the wire (**Figure 11-29, Page 11-27**).
  - 4.3. Using a multimeter set to 20k ohms, place the red (+) probe of the multimeter into the end of the spark plug cap that normally connects to the spark plug and place the black (–) probe into the end of the cap with the internal screw (**Figure 11-30, Page 11-27**). If the resistance is not between 4.5k - 6.0k ohms, the cap has failed and must be replaced. Proceed to the next step with the spark plug cap still removed.
5. Test the secondary coil separately from the spark plug cap.
  - 5.1. Using a multimeter set to 20k ohms, place the red (+) probe of the meter into the end of the spark plug wire and place the black (–) probe on the core (2) (**Figure 11-34, Page 11-29**). If the resistance is between 6.0k - 11.0k ohms, the secondary coil is within acceptable limits. If the resistance is not between 6.0k - 11.0k ohms, the ignition coil has failed and must be replaced.
6. If the preceding procedures indicate that the ignition coil resistance readings are within acceptable ranges, but the coil fails to function properly, replace the ignition coil and cap.

**TEST PROCEDURE 17 – KEY SWITCH (ENGINE KILL CIRCUIT)**

See **General Warning, Section 1, Page 1-1**.

1. Turn the key switch OFF and remove the key. Place the Forward/Reverse handle in the NEUTRAL position. Chock the wheels.
2. Disconnect battery and spark plug wire(s). See **Disconnecting The Battery on page 1-3**.
3. Remove the center dash assembly. See **Key Switch Removal, Section 12, Page 12-24**.
4. Remove the connector from the key switch.
5. Place the red (+) probe on the (M) terminal and the black (–) probe on the (G) terminal. With the key switch OFF, the reading should be continuity. With the key switch turned ON, the reading should be no continuity. If either reading is incorrect, replace the key switch (**Figure 11-35, Page 11-30**).
6. Reconnect the key switch to the wire harness. Ensure that the connector is connected correctly and is tight. If it is not, repair or replace as necessary.



**Figure 11-35 Test Key Switch – Engine Kill Circuit**

## TEST PROCEDURE 18 – ENGINE KILL WIRE

See General Warning, Section 1, Page 1-1.

1. Turn the key switch OFF and remove the key. Place the Forward/Reverse handle in the NEUTRAL position. Chock the wheels.
2. Disconnect battery and spark plug wire(s). **See Disconnecting The Battery on page 1-3.**
3. Disconnect white/black wire bullet connector located at the engine RPM limiter (**Figure 11-24, Page 11-24**).
4. Connect red (+) probe of multimeter to the male bullet terminal on the white/black wire and connect the black (-) probe to the vehicle frame.
5. With the Forward/Reverse handle in the NEUTRAL position, turn the key switch to the ON position and note the multimeter reading. Turn the key and hold it in the START position while noting the multimeter reading. There should be no continuity when the key switch is in the ON or START position. If there is continuity, check for worn insulation on the white/black wire that is allowing the wire to ground to the frame.

## TEST PROCEDURE 19 – REVERSE BUZZER LIMIT SWITCH

See General Warning, Section 1, Page 1-1.

**NOTE:** Keep the battery connected while performing this test procedure.

The reverse buzzer limit switch is located on the Forward/Reverse shifter; red/white and orange wires are connected to it.

1. Turn the key switch OFF and remove the key. Place the Forward/Reverse handle in the NEUTRAL position. Chock the wheels.
2. Move the Forward/Reverse handle to REVERSE and listen for an audible click from the limit switch. If there is no click, check the switch for proper alignment and switch arm movement.
3. If the switch is being activated but the buzzer does not function, place the red (+) probe of the multimeter on one terminal and the black (-) probe on the other terminal of the limit switch. Without the lever pressed, the reading should be no continuity. Press the lever and the reading should be continuity. If either reading is incorrect, replace limit switch.

## TEST PROCEDURE 20 – REVERSE BUZZER

See General Warning, Section 1, Page 1-1.

The front reverse buzzer is mounted to the center dash assembly under the front body on the Turf/Carryall 272 and XRT 1200, with an additional rear reverse buzzer mounted up under the rear of the bed on the Carryall 472 and XRT 1200 SE.

1. Turn the key switch OFF and remove the key. Place the Forward/Reverse handle in the NEUTRAL position. Chock the wheels.
2. Disconnect battery and spark plug wire(s). **See Disconnecting The Battery on page 1-3.**
3. To test the front reverse buzzer, remove the center dash panel. **See Key Switch Removal, Section 12, Page 12-24.** To test the rear reverse buzzer, raise the bed on the Carryall 472/XRT 1200 SE.
4. Check for proper wiring and tight connections. Using a multimeter, individually check for continuity through each wire that connects to the reverse buzzer. If the buzzer will not function when properly wired, replace the buzzer. **See Reverse Warning Buzzer, Section 12, Page 12-29.**

## TEST PROCEDURE 21 – OIL LEVEL SENSOR

See General Warning, Section 1, Page 1-1.

**NOTE:** Keep the battery connected while performing this test procedure.

1. Turn the key switch OFF and remove the key. Place the Forward/Reverse handle in the NEUTRAL position. Chock the wheels.
2. Disconnect battery and spark plug wire(s). See **Disconnecting The Battery on page 1-3**.
3. Ensure that the low oil warning light and all connecting wires are functioning correctly. See **Test Procedure 22 – Oil Warning Light on page 11-32**.
4. Drain the engine oil into an approved container and properly dispose of used oil.
5. Turn the key switch ON, closing the circuit. The oil light should illuminate. If the low oil warning light does not illuminate, the oil level sensor may need to be replaced. Refer to Test Procedure 22 before replacing sensor. See **Oil Level Sensor Removal, Section 13, Page 13-5**.
6. Fill the engine with new oil and install a new oil filter before returning the vehicle to service. See **Engine Oil And Filter Change on page 10-5**.

## TEST PROCEDURE 22 – OIL WARNING LIGHT

See General Warning, Section 1, Page 1-1.

1. Turn the key switch OFF and remove the key. Place the Forward/Reverse handle in the NEUTRAL position. Chock the wheels.
2. Disconnect battery and spark plug wire(s). See **Disconnecting The Battery on page 1-3**.
3. Remove the center dash assembly. See **Key Switch Removal, Section 12, Page 12-24**.
4. Ensure that the wires are connected correctly and are tight. If they are not, rewire or tighten as necessary.
5. Disconnect the yellow wire (to the oil level sensor) from the terminal on the oil light. Using an alligator clip jumper wire, connect the oil light terminal to the vehicle frame. Connect the red (+) battery cable to the positive (+) battery post, then attach the black (–) cable to the negative (–) battery post.
6. Turn the key switch to the ON position. The oil light should illuminate. If it does not, check continuity of the yellow wire that connects the key switch to the oil light through a sonic weld connection within the wire harness. If there is no continuity in the wire, replace the wire. Then test the key switch. See **Test Procedure 4 – Key Switch (Starter Circuit) on page 11-15**. If the yellow wire and the key switch test okay, then replace the oil light.

## TEST PROCEDURE 23 – LOCKOUT CAM

See General Warning, Section 1, Page 1-1.

1. Check to be sure the lobes on the cam are pressing the lockout cam limit switch when the Forward/Reverse shifter is in the NEUTRAL position only. The limit switch should make an audible click as it is pressed. If it does not, check for wear on the cam lobe. If the cam lobe will not activate the limit switch, replace the cam.



**TEST PROCEDURE 24 – BATTERY TEST (UNDER LOAD)****See General Warning, Section 1, Page 1-1.****NOTE:** *Keep the battery connected while performing this test procedure.*

1. Turn the key switch OFF and remove the key. Place the Forward/Reverse handle in the NEUTRAL position. Chock the wheels.
2. Set a multimeter to 20 volts and place the red (+) probe on the F2 (white wire) terminal on the starter/generator. Place the black (–) probe on the negative battery post.
3. Turn the key switch to the START position and hold it in the START position while noting the voltage reading on the multimeter (with the key in the START position the battery is under load).
  - 3.1. If the voltage reading is over 9.6 volts at 70 °F (21 °C) (electrolyte temperature) check the starter/generator. **See following NOTE.**

**NOTE:** *The voltage reading is taken at 70 °F (21 °C). At lower electrolyte temperatures the voltage reading will be lower.*

- 3.2. If the reading is below 9.6 volts at 70 °F (21 °C) (electrolyte temperature), check the battery. **See Test Procedure 1 – Battery on page 11-11.**
- 3.3. If the reading is zero, there may be NO continuity across the large posts of the solenoid. **See Test Procedure 6 – Solenoid on page 11-17.**
4. If all of the test results are good and the voltage reading is zero, there may be a broken or damaged 6-gauge white wire from the solenoid to the starter/generator. **See Test Procedure 8 – Starter/Generator (Starter Function) on page 11-19.**

**TEST PROCEDURE 25 – FUEL LEVEL SENDING UNIT****See General Warning, Section 1, Page 1-1.**** WARNING**

- **To avoid the possibility of fire or explosion, make sure the fuel tank cap is securely in place while performing this test procedure.**

1. Turn the key switch to OFF and remove the key. Place the Forward/Reverse handle in the NEUTRAL position. Chock the wheels.
2. Disconnect battery and spark plug wire(s). **See Disconnecting The Battery on page 1-3.**
3. Disconnect the orange wire from the center post of the fuel level sending unit.
4. With a multimeter set to 2k ohms, place the red (+) probe of the multimeter on the center post of the sending unit. Place the black (–) probe on the ground connection of the sending unit (**Figure 11-36, Page 11-34**).
5. The following resistance readings (in ohms) should be obtained depending on the position of the float inside the fuel tank. The resistance reading will vary according to the exact position of the float. The chart below may be used as a guideline to determine if the fuel level sending unit is operating correctly. Make sure the float is at the surface of the fuel in the tank.

FLOAT POSITION	RESISTANCE READING	FUEL GAUGE READINGS
Lower position (tank empty)	240 ± 20 ohms	Empty
Center position (tank half full)	120 ± 20 ohms	Half full
Upper position (tank full)	60 ± 20 ohms	Full

**Test Procedure 25 – Fuel Level Sending Unit, Continued:**

6. If the readings are within the specifications listed above, the fuel level sending unit is working properly. If the readings are incorrect, the fuel level sending unit has failed and the fuel tank must be replaced. **See Fuel Tank Removal, Section 14, Page 14-22.**
7. If the readings are correct and the fuel gauge does not function correctly, check the continuity of the orange wire from the fuel level sending unit to the fuel gauge/hour meter. Leave the battery disconnected while checking continuity. Also check the continuity of the yellow wire from the fuel gauge/hour meter to the key switch, and the black ground wires at the fuel level sending unit and at the fuel gauge/hour meter. **See Fuel Gauge/Hour Meter Removal, Section 12, Page 12-32.**
8. If the readings are correct according to the position of the float, but give an incorrect reading on the fuel gauge/hour meter, test the fuel gauge/hour meter. **See Test Procedure 26 – Fuel Gauge on page 11-34.**

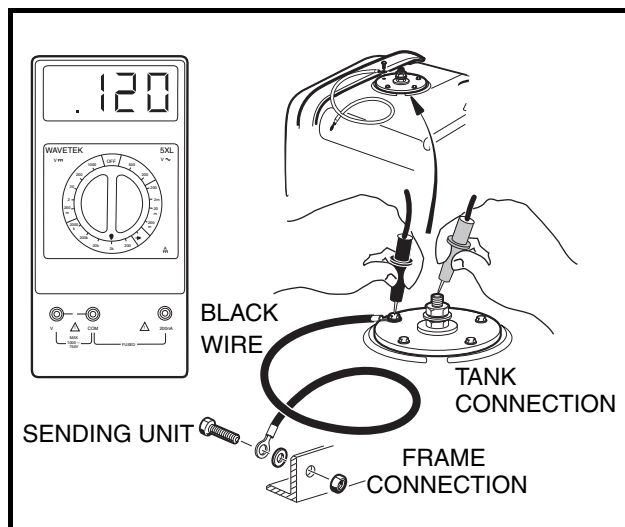


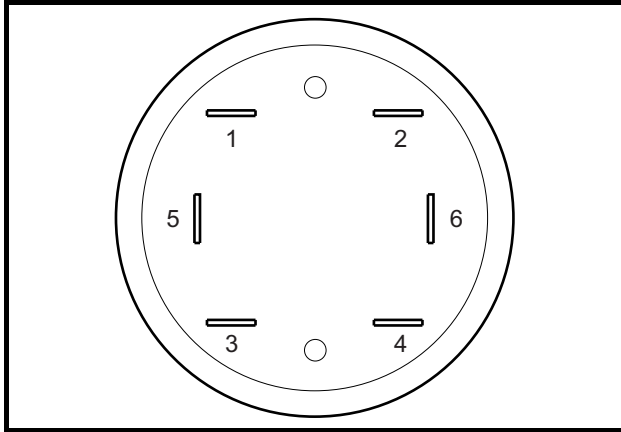
Figure 11-36 Test Fuel Level Sending Unit

**TEST PROCEDURE 26 – FUEL GAUGE**

**See General Warning, Section 1, Page 1-1.**

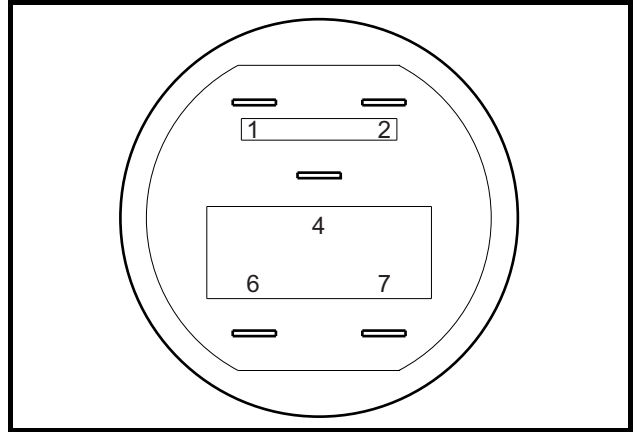
Two fuel gauges were used for model year 2007 (**Figure 11-37, Page 11-35 and Figure 11-38, Page 11-35**). The terminal configuration on the back of the gauge easily denotes the type. Follow the appropriate procedure. The gauge used through mid-2007 has the orange wire connected to terminal 1 whereas the gauge used from mid-2007 has it connected to terminal 4 in the center of the gauge. In addition, the gauge used through mid-2007 has one terminal (3) to ground it whereas the gauge used from mid-2007 has two ground terminals (1 and 6) with a black jumper wire connecting them. **See following NOTE.**

**NOTE:** Keep the battery connected during this test procedure.



**Figure 11-37 Fuel Gauge/Hour Meter – Through mid-2007**

1. Orange 2. Blue 3. Black 4. White 5. Not used 6. Not used



**Figure 11-38 Fuel Gauge/Hour Meter – From mid-2007**

1. Black(Jumper Wire From 6) 2. Blue 4. Orange 6. Black 7. White

### Test Procedure 26A – Fuel Gauge (Through mid-2007)

1. Turn the key switch OFF and remove the key. Place the Forward/Reverse handle in the NEUTRAL position. Chock the wheels.
2. Remove the instrument panel to gain access to the back of the fuel gauge/hour meter. **See Key Switch Removal, Section 12, Page 12-24.**
3. Place a sheet of insulating material between the front frame and the electrical connections on the rear of the instrument panel to prevent contact between the two.
4. Disconnect the orange wire from the fuel gauge/hour meter.
5. Set a multimeter to 20 volts DC and place the red (+) probe of the multimeter on the positive post of the battery. Place the black (–) probe on the negative post of the battery. Record the voltage reading.
6. Set a multimeter to 20 volts DC and place the red (+) probe of the multimeter on the (2) terminal of the fuel gauge/hour meter with the blue wire. Place the black (–) probe on the (3) terminal of the fuel gauge/hour meter with the black wire (**Figure 11-39, Page 11-36**).
7. Connect battery and spark plug wire(s). **See Connecting The Battery on page 1-3.**
8. Turn the key switch ON. The voltage reading should be the same as the battery voltage reading recorded earlier. If not, check the continuity of the blue and black wires (**Figure 11-39, Page 11-36**).
9. The orange wire should remain disconnected for this step. With the black probe still on the (3) terminal of the fuel gauge/hour meter, place the red (+) probe of the multimeter on the (1) terminal of the fuel gauge/hour meter (**Figure 11-40, Page 11-36**). The voltage reading should be approximately 1.81 volts. If the reading is incorrect, replace fuel gauge/hour meter.

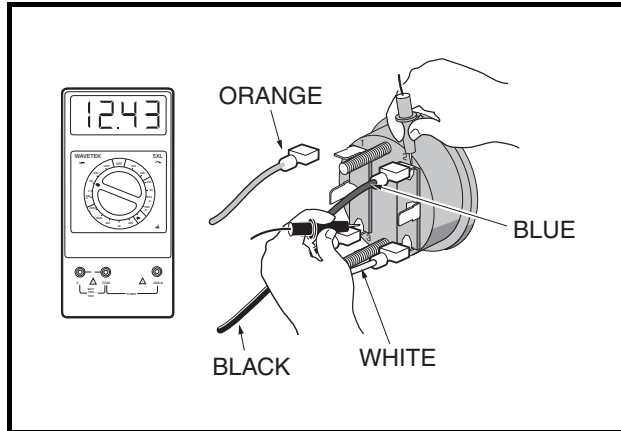


Figure 11-39 Test Fuel Gauge Continuity

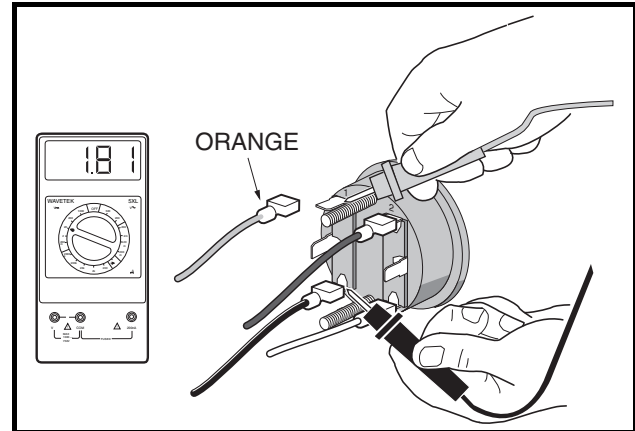


Figure 11-40 Test Fuel Gauge Voltage

### Test Procedure 26B – Fuel Gauge (From mid-2007)

1. Turn the key switch OFF and remove the key. Place the Forward/Reverse handle in the NEUTRAL position. Chock the wheels.
2. Remove the center dash assembly to gain access to the back of the fuel gauge/hour meter. **See Key Switch Removal, Section 12, Page 12-24.**
3. Place a sheet of insulating material between the front frame and the electrical connections on the rear of the center dash assembly to prevent contact between the two.
4. Disconnect the orange wire from the fuel gauge/hour meter.
5. Set a multimeter to 20 volts DC and place the red (+) probe of the multimeter on the positive post of the battery. Place the black (-) probe on the negative post of the battery. Record the voltage reading.
6. Set a multimeter to 20 volts DC and place the red (+) probe on the (2) terminal of the fuel gauge/hour meter where the blue wire (w25) is connected. Place the black (-) probe on the (1) terminal of the fuel gauge/hour meter with the black wire (w22) (**Figure 11-41, Page 11-37**).
7. Connect battery and spark plug wire(s). **See Connecting The Battery on page 1-3.**
8. Turn the key switch ON. The voltage reading should be the same as the battery voltage reading recorded earlier. If not, check the continuity of the blue and black wires (**Figure 11-41, Page 11-37**).
9. The orange wire should remain disconnected for this step. Place the black probe of the multimeter on the (1) terminal of the fuel gauge/hour meter and place the red (+) probe on the (4) terminal of the fuel gauge/hour meter (**Figure 11-42, Page 11-37**). The voltage reading should be approximately 4.94 volts. If the reading is incorrect, replace the fuel gauge/hour meter.

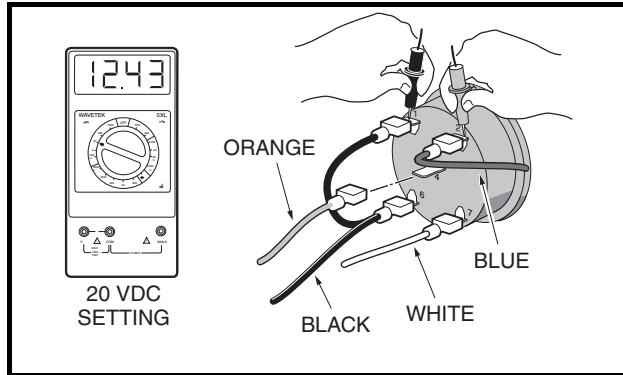


Figure 11-41 Fuel Gauge Voltage Test - Terminal 2

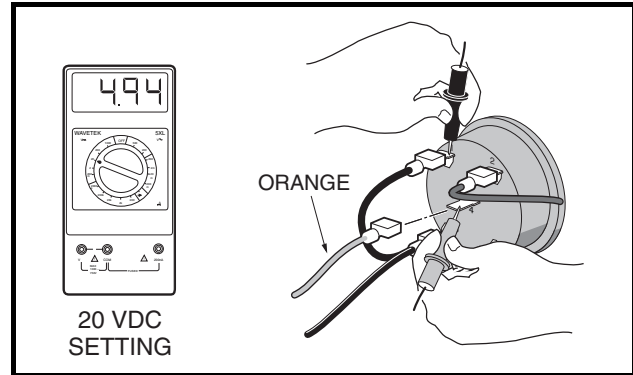


Figure 11-42 Fuel Gauge Voltage Test - Terminal 4

## TEST PROCEDURE 27 – HOUR METER

### See General Warning, Section 1, Page 1-1.

Two hour meters were used for model year 2007 (Figure 11-37, Page 11-35 and Figure 11-38, Page 11-35). The display and the terminal configuration on the back of the meter easily denotes the type. Follow the appropriate procedure. The display on the meter used through mid-2007 only appears when the key switch is ON whereas the display on the meter used from mid-2007 is always on. The meter used through mid-2007 has the orange wire connected to terminal 1 whereas the meter used from mid-2007 has it connected to terminal 4 in the center of the meter. In addition, the meter used through mid-2007 has one terminal (3) to ground it whereas the meter used from mid-2007 has two ground terminals (1 and 6) with a black jumper wire connecting them. **See following NOTE.**

**NOTE:** Keep the battery connected while performing this test procedure.

### Test Procedure 27A – Hour Meter (Through mid-2007)

1. Place the Forward/Reverse handle in NEUTRAL. Chock the wheels.
2. Turn the key switch ON to verify the display appears.
3. Start the engine and let it idle. **See following DANGER.**

#### **⚠ DANGER**

- Do not operate vehicle in an enclosed area without proper ventilation. The engine produces carbon monoxide, which is an odorless, deadly poison.

4. With engine idling, the "hour glass" icon should flash slowly. If not, check the low oil warning light and the oil pressure switch. **See following NOTE.** **See also Test Procedure 22 – Oil Warning Light on page 11-32.**

**NOTE:** The hour meter is designed to record actual engine running time and will not start adding increments until the engine is running and the oil pressure switch has opened.

5. If the hour meter still does not function after the low oil warning light, oil pressure switch, and all of the appropriate wires have been checked for continuity, replace the fuel gauge/hour meter.

### Test Procedure 27B – Hour Meter (From mid-2007)

1. Place the Forward/Reverse handle in NEUTRAL. Chock the wheels.

2. With the key switch OFF, check the hour meter display. It is powered by an internal battery and should always be on, even with the engine off and the key removed.
3. Start the engine and let it idle. **See following DANGER.**

### **DANGER**

- **Do not operate vehicle in an enclosed area without proper ventilation. The engine produces carbon monoxide, which is an odorless, deadly poison.**
4. With engine idling, the "hour glass" icon should flash. If not, check the low oil warning light and the oil pressure switch. **See following NOTE. See also Test Procedure 22 – Oil Warning Light on page 11-32.**

**NOTE:** *The hour meter is designed to record actual engine running time and will not start adding increments until the engine is running and the oil pressure switch has opened.*

5. If the hour meter still does not function after the low oil warning light, oil pressure switch, and all of the appropriate wires have been checked for continuity, replace the fuel gauge/hour meter.

## **TEST PROCEDURE 28 – LIGHT SWITCH**

**See General Warning, Section 1, Page 1-1.**

1. Turn the key switch OFF and remove the key. Place the Forward/Reverse handle in the NEUTRAL position. Chock the wheels.
2. Disconnect battery and spark plug wire(s). **See Disconnecting The Battery on page 1-3.**
3. Remove the center dash assembly. **See Key Switch Removal, Section 12, Page 12-24.**
4. Using a multimeter set on 20 volts DC, place alligator clips on the multimeter probes. Connect the red (+) probe to the light switch terminal with the blue wire connected to it (**Figure 11-43, Page 11-39**).

### **CAUTION**

- **Before connecting battery cables, make sure none of the electrical components touch the front body trim or other parts of the vehicle frame. Place a dry towel between the body trim and the center dash to prevent an electrical short.**
5. Connect battery and spark plug wire(s). **See Connecting The Battery on page 1-3.**
  6. Connect the black (–) probe of the multimeter to the negative (–) post of the battery.
  7. With the light switch in the OFF position, the reading should be zero volts. With the light in the ON position, the reading should be between 11 and 12.5 volts. If there is no voltage reading, check continuity of the 10-gauge red wire from the fuse block to the solenoid. Check continuity of the 14-gauge yellow wire from the light switch to the fuse block. Check the fuse. **See Test Procedure 2 – Fuse on page 11-13.** If the headlight diode is functioning correctly, the wires and fuse show continuity and the readings are still incorrect, replace the switch. **See Light Switch Removal, Section 12, Page 12-39.**

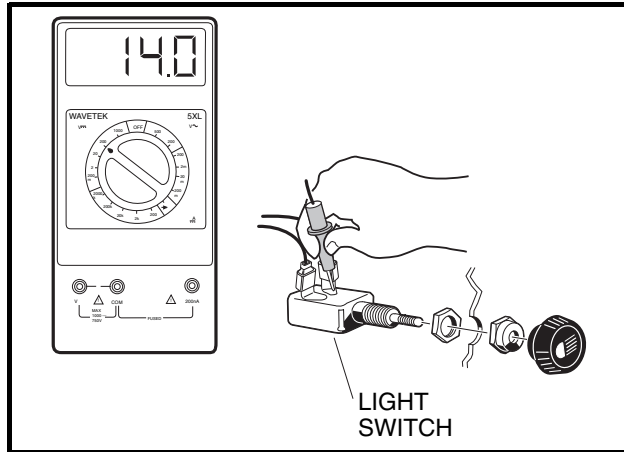


Figure 11-43 Light Switch Test

## TEST PROCEDURE 29 – HEADLIGHT DIODE

See General Warning, Section 1, Page 1-1.

1. Turn the key switch OFF and remove the key. Place the Forward/Reverse handle in the NEUTRAL position. Chock the wheels.
2. Disconnect battery and spark plug wire(s). **See Disconnecting The Battery on page 1-3.**
3. Remove the center dash assembly. **See Key Switch Removal, Section 12, Page 12-24.**
4. Using a multimeter set on 20 volts DC, connect the red (+) probe to the light switch terminal with the yellow wire (**Figure 11-44, Page 11-40**).
5. Loosen the black wire connector (on the end of the long black wire) at the headlight diode assembly just enough to maintain the connection and yet expose part of the metal terminal in the connector. Place black (-) probe on the connector (**Figure 11-44, Page 11-40**). **See following CAUTION.**

### **⚠ CAUTION**

- **Before connecting battery cables, make sure no electrical components touch the front body trim or other parts of the vehicle frame. Place a dry towel between the body trim and the center dash to prevent an electrical short circuit.**

6. Connect battery and spark plug wire(s). **See Connecting The Battery on page 1-3.**
7. Pull the light switch to the ON position. The reading should be 11-12 volts. If there is no voltage reading, check continuity of the 16-gauge black wire from the headlight to the headlight diode. Check continuity of the 16-gauge black wire from headlight diode to the vehicle frame. If the wires show continuity and the readings are still incorrect, replace the headlight diode. **See Headlight Diode Removal, Section 12, Page 12-38.**
8. With the Forward/Reverse handle in the NEUTRAL position and the wheels chocked, start the engine and press the accelerator pedal to the floor.
9. Push the light switch to the OFF position. The reading should be 14.7-15.3 volts.
10. Pull the light switch to the ON position. The reading should be 11-13 volts. If the reading does not drop from 14.5-15.5 volts to 11-13 volts, replace the voltage limiter.

## TEST PROCEDURE 30 – VOLTAGE AT HEADLIGHT SOCKET

See General Warning, Section 1, Page 1-1.

**NOTE:** Keep the battery connected while performing this test procedure.

1. Turn the key switch OFF and remove the key. Place the Forward/Reverse handle in the NEUTRAL position. Chock the wheels.
2. Inspect wires at light bulb socket. Make sure wires are securely fastened to the contacts inside socket.

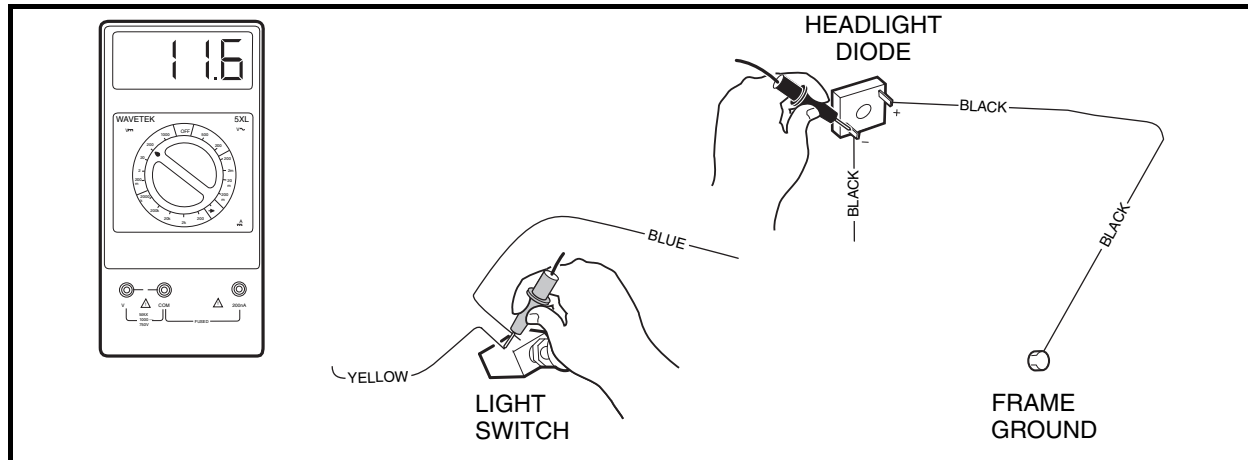


Figure 11-44 Headlight Diode Circuit Test

3. Remove the wire harness from the headlight (**Figure 11-45, Page 11-41**).
4. Using a multimeter set to 20 volts DC, place the black (–) probe of multimeter into the black wire terminal of the wire harness. Place the red (+) probe into the blue wire terminal.
5. Pull the light switch to the ON position. If the multimeter reads approximately 12 volts, replace the headlight bulb.
6. If there is no voltage reading at the wire harness, check continuity of the 16-gauge blue wire from the headlight to the light switch. Using a multimeter set to 20 volts DC, attach using an alligator clip, the black (–) probe of multimeter onto the negative battery terminal and place the red (+) probe into the blue wire terminal of wire harness. If the multimeter reading is approximately 12 volts, the blue wire has continuity.
7. Check continuity of the 16-gauge black wire from the headlight to the ground terminal. Using a multimeter set to 20 volts DC, place the black (–) probe of multimeter into the black wire terminal of the wire harness and attach using an alligator clip, the red (+) probe onto the positive battery terminal. If the multimeter reading is approximately 12 volts, the black wire has continuity.



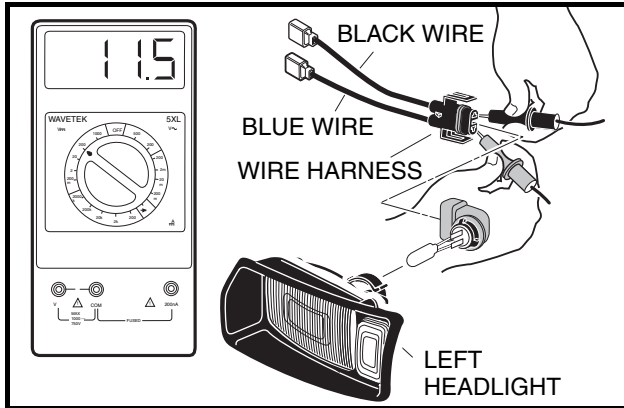


Figure 11-45 Check Voltage to Headlight Socket



## SECTION 12 – ELECTRICAL COMPONENTS: FE400, KEY-START ENGINE

### **⚠ DANGER**

- See General Warning, Section 1, Page 1-1.

### **⚠ WARNING**

- See General Warning, Section 1, Page 1-1.

### STARTER/GENERATOR (MODEL G425419)

See General Warning, Section 1, Page 1-1.

#### Testing the Starter/Generator

See Test Procedure 8, Section 11, Page 11-19. Also See Test Procedure 11, Section 11, Page 11-22.

#### Starter/Generator Removal

1. Disconnect battery and spark plug wire(s). **See Disconnecting The Battery on page 1-3.**
2. Mark and disconnect the wires from the starter/generator (1). Loosen the two pivot nuts (7) and bolts (5) (Figure 12-1, Page 12-1).

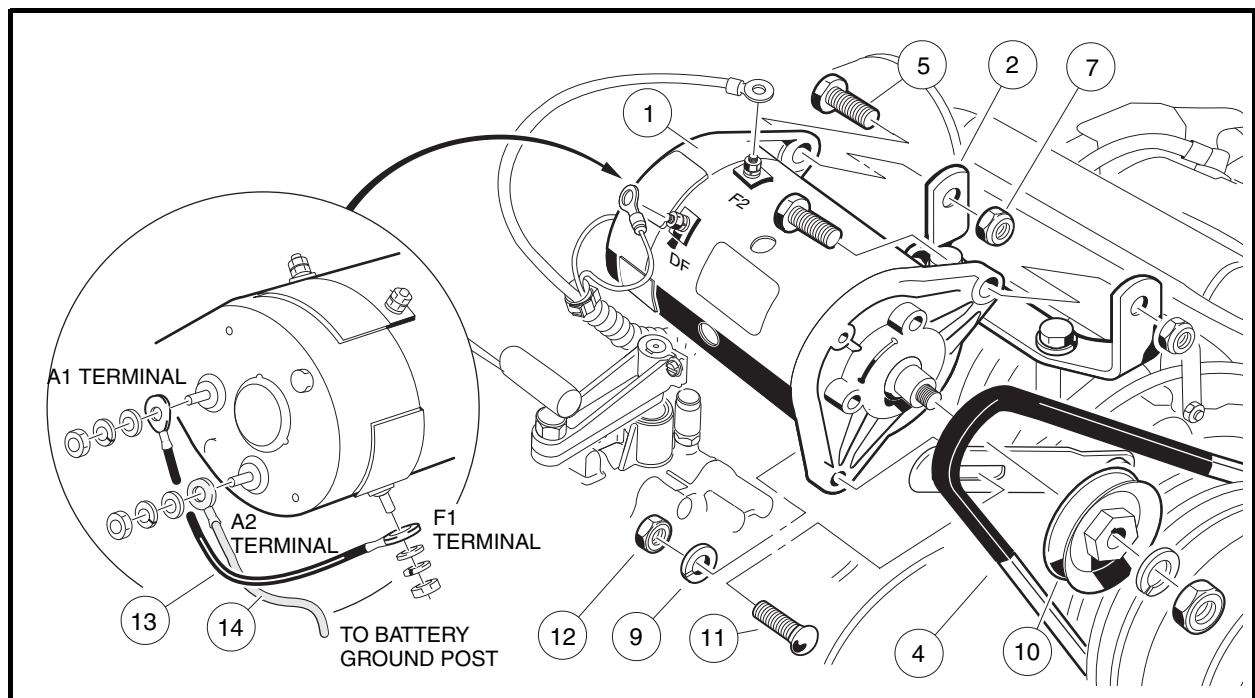


Figure 12-1 Starter/Generator Mounting

3. Remove the mounting/adjustment nut (12), washer (9) and bolt (11). Lower the starter/generator and slip the belt (4) off the pulley (10).
4. Support the starter/generator so that when the pivot bolts are removed the starter/generator will not fall to the ground. Remove the two pivot nuts (7) and bolts (5) from the mounting bracket.
5. Remove the starter/generator.

### Disassembly of the Starter/Generator to Service the Brushes

1. Remove the two bolts (20) and pull commutator end cover (23) free of starter/generator housing (24) (Figure 12-2, Page 12-2). See following NOTE.

**NOTE:** Brushes must be removed to avoid damage from commutator removal. Lift the brush springs out of the notches in the brushes and pull the brushes back from the center of the commutator end cover. The springs will help prevent them from sliding back towards the center (Figure 12-6, Page 12-4).

2. Remove brush covers (29 and 30), screws (25), lockwashers (26), brush springs (28) and brushes (27) (Figure 12-3, Page 12-2). See following NOTE.

**NOTE:** To clean and inspect the armature/commutator and the bearings, see *Disassembly of the Starter/Generator to Service the Armature/Commutator on page 12-3*.

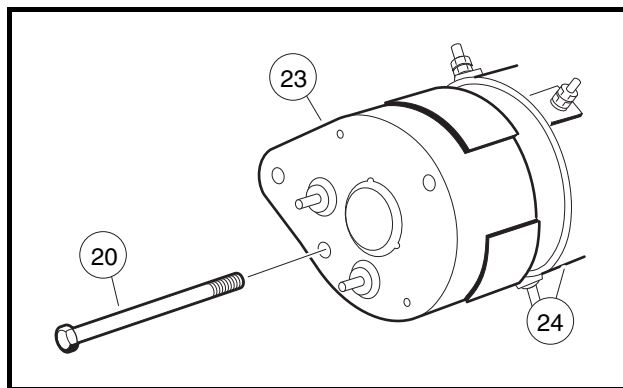


Figure 12-2 Commutator End Cover

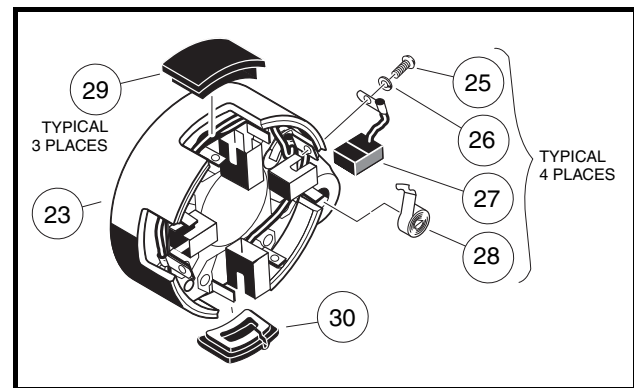


Figure 12-3 Brush Covers and Brushes

### Brush Inspection and Replacement

1. Visually inspect brushes. Replace brushes that are cracked or severely chipped.
2. Check the wear line on the side of the brush. If the end of the brush is within 1/16-inch (1.6 mm) of the wear line, replace all four brushes (Figure 12-4, Page 12-2).

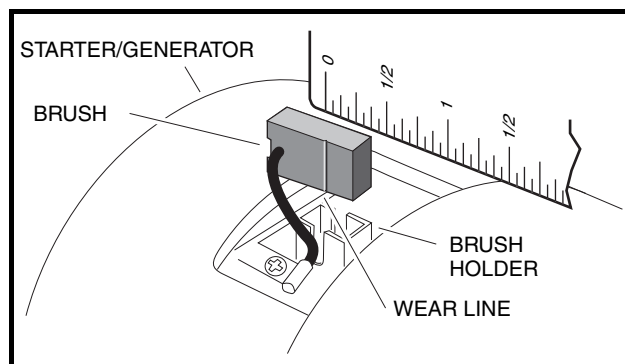


Figure 12-4 Inspect Brushes

## Brush Spring Inspection and Replacement

1. Visually inspect springs. Replace all four springs if any spring is discolored from heat (straw or bluish in color).
2. Install the four brushes (27) into their holders and insert the four brush springs (28) (**Figure 12-3, Page 12-2**). Using a spring scale, test brush spring tension. If any spring has a tension less than 24 ounces (6.67 N), replace all four springs (**Figure 12-5, Page 12-3**). See following **CAUTION**.

### **CAUTION**

- When checking brush spring tension, do not push springs beyond the point they would normally be if there were new brushes installed. Exerting excessive force or pushing brush springs beyond their normal maximum extension point will damage springs.

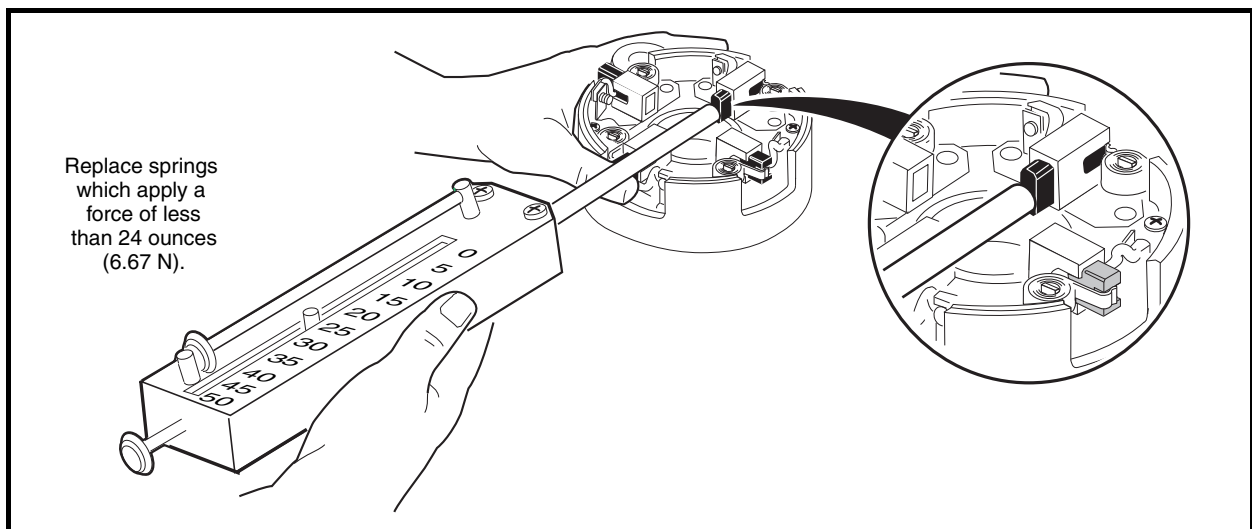


Figure 12-5 Brush Spring Tension Test

## Starter/Generator Assembly

1. Connect the brush wires to the holders using four lockwashers (26) and four screws (25). Make sure the crossover leads are also connected. Tighten the screws to 31 in-lb (3.5 N·m) (**Figure 12-3, Page 12-2**).
2. Install the commutator. Lift the brush springs out of the notches in the brushes and pull the brushes back from the center of the commutator end cover to avoid interference. The springs will rest on the sides of the brushes and help prevent them from sliding to the center (**Figure 12-6, Page 12-4**).
3. Install the commutator end cover (23) onto the armature shaft. Align the locating pin and hole in the cover. Install two M6 x 180 mm bolts (20) and tighten to 100 in-lb (11.3 N·m) (**Figure 12-2, Page 12-2**).
4. Push the brushes down into the holders. Place springs into the notches in the brushes. Install the brush cover (30) that has the drain hole in it next to the A2 terminal. Install the remaining three brush covers (29) onto the openings in the commutator end cover (23) (**Figure 12-3, Page 12-2**).

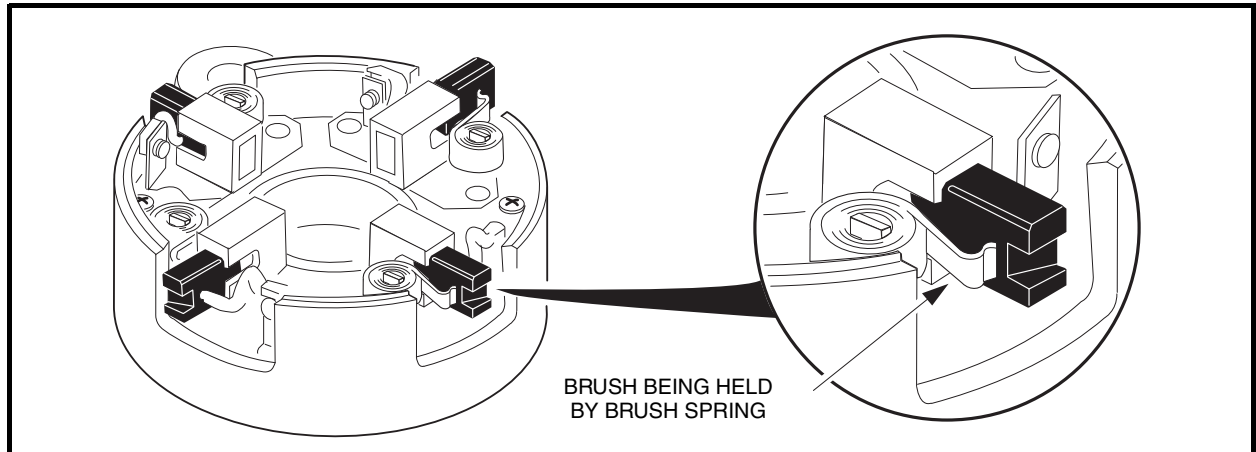
## Disassembly of the Starter/Generator to Service the Armature/Commutator

1. Remove the two bolts (20), and pull commutator end cover (23) free of the starter/generator housing (24) (**Figure 12-2, Page 12-2**). See following **NOTE**.

**NOTE:** Brushes must be removed to avoid damaged from commutator removal. Lift the brush springs out of the notches in the brushes and pull the brushes back from the center of the commutator and

cover. The springs will help prevent them from sliding back towards the center (**Figure 12-6, Page 12-4**).

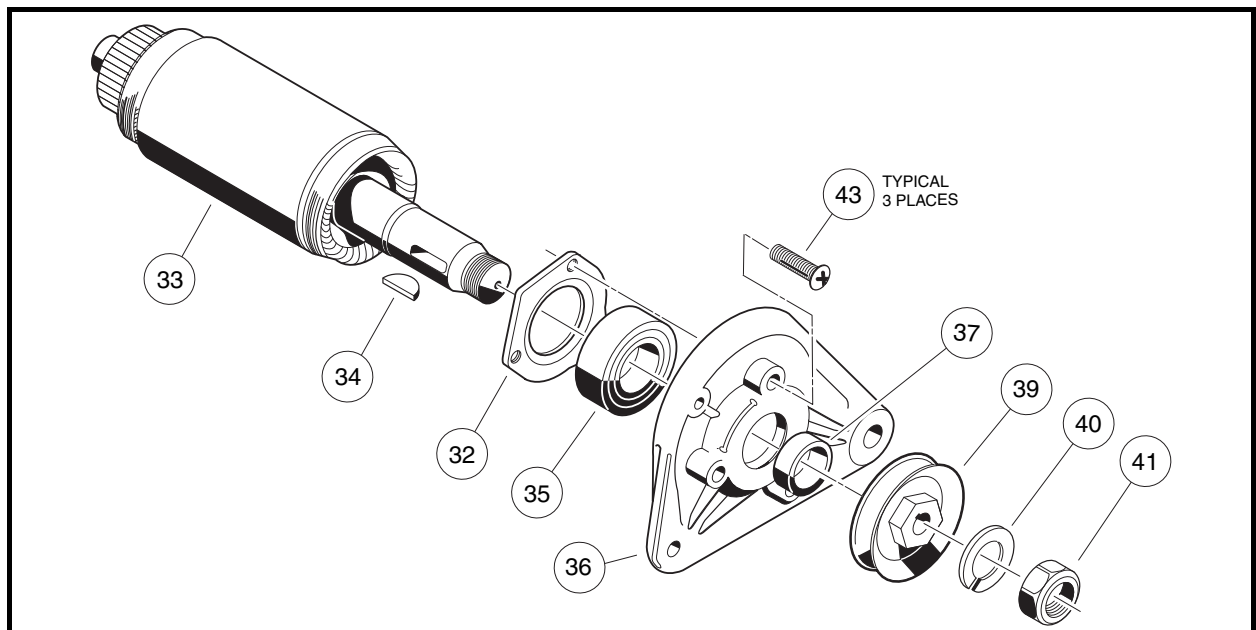
2. Remove nut (41), lockwasher (40), pulley (39), shaft key (34), spacer (37) and bearing retainer screws (43) and separate armature (33) from output end cover (36) (**Figure 12-7, Page 12-4**).



**Figure 12-6 Pull Brushes Away From Center of the Commutator End Cover**

### Bearing Cleaning and Inspection

1. Wipe the carbon dust from the two bearings. Inspect bearings by spinning them by hand and checking for both axial (A) and radial (B) play (**Figure 12-8, Page 12-5**).
2. Replace the bearing if it is noisy, does not spin smoothly or has excessive play. Replace if rusted, worn, cracked, or if there is an abnormal color change in the metal of the bearing. Replace if there is extensive wear or pitting on the balls or rolling surfaces. Do not remove bearings unless they are to be replaced.



**Figure 12-7 Armature and Output End Cover Assembly**

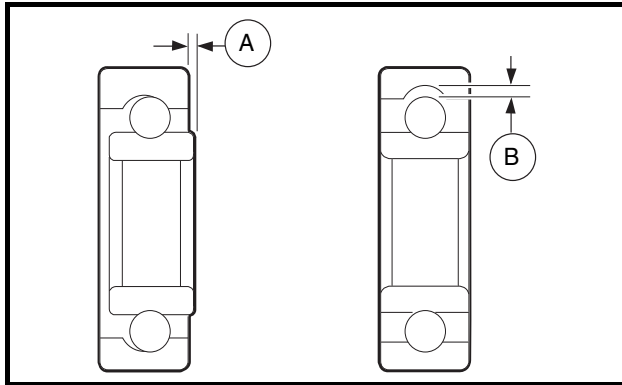


Figure 12-8 Bearing Play Inspection

## Bearing Removal

1. Place the wedge attachment tool (CC P/N 1012812) between the bearing and the armature. Make sure the wedge attachment tool is supporting the inner race of the bearing. If a press is not available, secure a bearing puller (CC P/N 1012811) to the wedge attachment tool and pull the bearing off of the end of the armature shaft. Support the armature so that it will not drop when the bearing is removed (Figure 12-9, Page 12-5).
2. Discard the bearings.
3. Slide the bearing retainer (32) off of the output end of the shaft (Figure 12-7, Page 12-4).

## Field Coil Removal

1. Remove the retaining nut from each field coil terminal and slide the insulator out of the slots in the housing. Remove the four pole piece screws from the housing. Remove the four pole pieces from inside the housing. Remove the field coils from the inside of the housing (Figure 12-10, Page 12-6). See following NOTE.

**NOTE:** Do not remove the insulators or the field coils unless an electrical test indicates that it is necessary (Figure 12-10, Page 12-6). See Test Procedure 8, Section 11, Page 11-19.

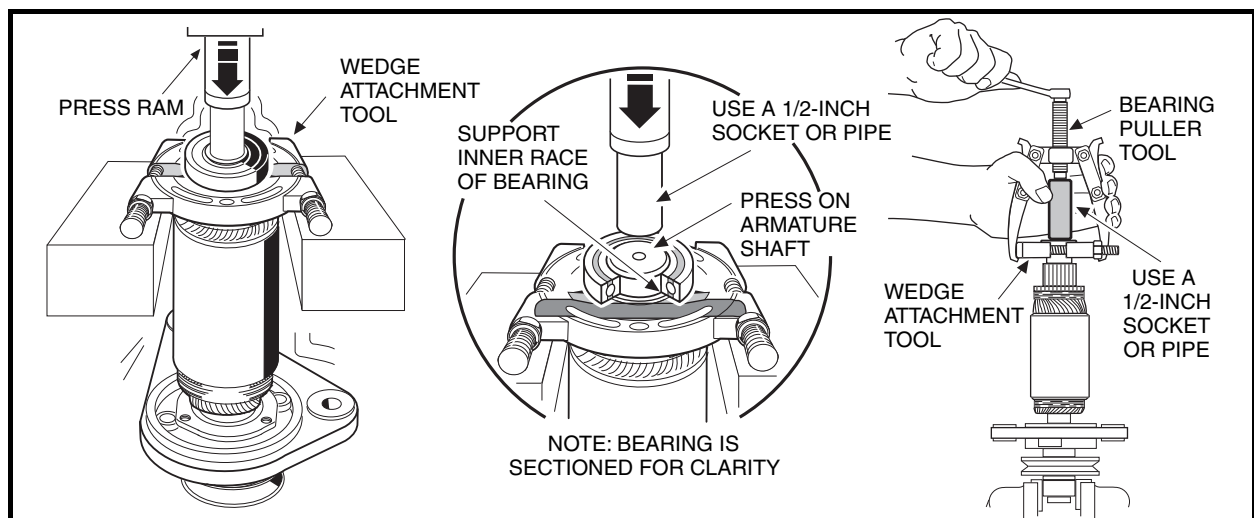


Figure 12-9 Bearing Removal

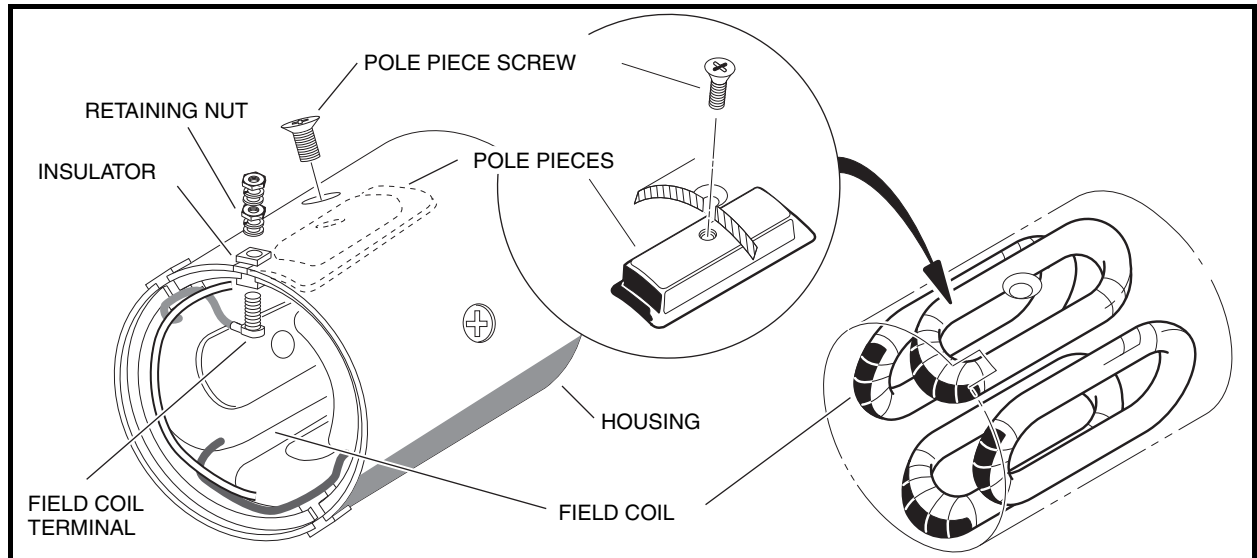


Figure 12-10 Field Coil Removal

### Visual Inspection of Armature and Commutator

Some defects can be seen by examining the armature and commutator. Defects seen during the visual inspection can aid in diagnosing the original cause of the failure. Items to look for are listed below.

- Burned, charred or cracked insulation
- Improperly cured varnish
- Thrown solder
- Flared armature windings
- Worn, burned or glazed commutator
- Loose or raised commutator bars
- Bruised or damaged armature core laminations
- Worn armature bearing or shaft
- Dirty or oily commutator

### Commutator Cleaning and Inspection

1. Clean the carbon dust, dirt and oil from the commutator. Slight roughness of the commutator can be polished away with 400 grit (or finer) sandpaper. **See following CAUTION.**

#### **CAUTION**

- **Never use emery cloth on the commutator. Particles of emery are conductive and may short-circuit the commutator bars. Never use oil or lubricants on the commutator or brushes.**
2. Use a micrometer and measure the outside diameter at four points: two points 90° to each other to the outside end of the commutator (A<sup>1</sup> and A<sup>2</sup>), and two points 90° to each other to the inside of the commutator (B<sup>1</sup> and B<sup>2</sup>). If the commutator diameter is less than 1.535 inches (39 mm) at any of the four locations, replace the armature assembly and bearings (**Figure 12-11, Page 12-7**).



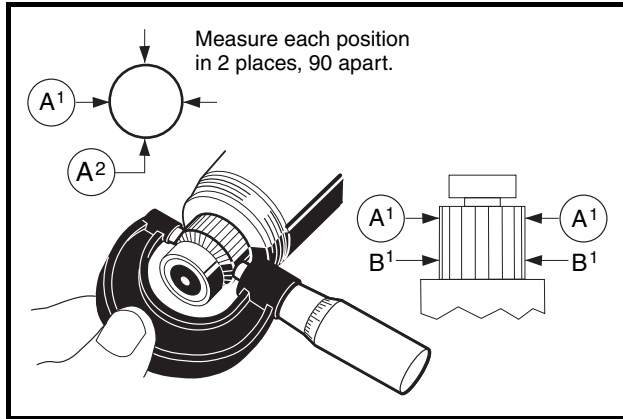


Figure 12-11 Inspect Commutator

## Armature Ground Test

### CAUTION

- Do not submerge armature in solvent.

**NOTE:** Before testing, wipe the armature with a clean cloth and remove carbon dust and metal particles from between commutator bars.

1. Use a multimeter set on 200 ohms and place the positive (+) probe on the commutator bars and the negative (–) probe on the armature core. The reading should be no continuity. If the reading is incorrect, replace the armature and the two bearings (**Figure 12-12, Page 12-7**).

## Visual Inspection of Field Coils

Burned, blackened, charred or scorched coil insulation indicates the starter/generator has overheated due to overloads, grounding or shorted coil windings and should be replaced. Be sure the insulators are tight in the housing.

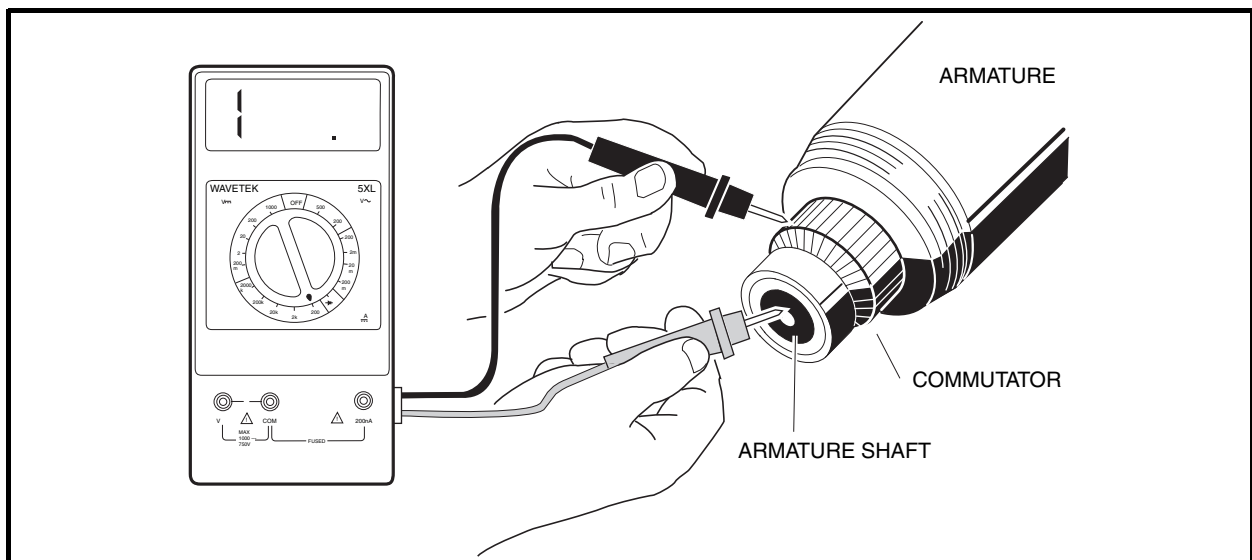


Figure 12-12 Armature Ground Test

## Starter/Generator Rework

Any rework must be performed by a qualified technician. Starter/Generator service specifications are listed in the following table.

ITEM	SERVICE LIMIT
Commutator diameter (minimum)	1.535 in. (39 mm)
Concentric with armature shaft within	0.002 in. (0.051 mm)
Limit depth of cut when machining commutator	0.007 in. (0.2 mm)
If undercut of segment insulator is less than 0.016 inch (0.406 mm), then it should be undercut to	0.031 in. (0.8 mm)
Dielectric strength	500 VAC for one minute
Armature insulation resistance	0.2M ohms at 500 VDC
Starter field coil resistance	0.006-0.01 ohms
Generator field coil resistance	4.5-5.5 ohms

## Starter/Generator Assembly

1. Place the field coil into the housing. The two insulators that look alike fit into the slots next to the F1 and F2 markings on the outside of the housing. The insulator that looks different slides into the slot next to the DF marking.
2. After the insulators are seated in the slots, install the threaded terminals through the wire connectors and then through the insulators. Install a flat washer, lockwasher and nut onto each threaded terminal on the outside of the housing. Tighten nuts to 47.5 in-lb (5.4 N·m) (**Figure 12-10, Page 12-6**). **See following CAUTION.**

### **CAUTION**

- **Route the field terminal wires so that they will not contact the armature.**
3. Install the four pole pieces into the housing. Use the four screws to secure pole pieces to the inside of the housing to retain the field wires. Tighten screws to 9 ft-lb (12.2 N·m) (**Figure 12-10, Page 12-6**).
  4. Slide the bearing retainer onto the output end of the armature shaft (33) so that it will hold the outside of the bearing (35) only (**Figure 12-7, Page 12-4**).
  5. Press a new ball bearing (35) onto the output end of the armature (**Figure 12-7, Page 12-4**). Press a new ball bearing onto the commutator end of the armature shaft. **See following CAUTION.**

### **CAUTION**

- **Use care while pressing new bearing onto the output end of the shaft to prevent damage to the retainer.**
  - **Press against the inner race of the new bearing until it is fully seated.**
6. Install the output end cover (36) onto the armature. Secure the bearing retainer (32) to the cover and tighten the screws (43) to 39 in-lb (4.4 N·m) (**Figure 12-7, Page 12-4**).

7. Slide the housing with field coils over the armature. Use the locating pin to align housing to the cover.

**NOTE:** The terminal insulators should be on the commutator end of the housing.

8. Install the commutator. Lift the brush springs out of the notches in the brushes and pull the brushes back from the center of the commutator end cover to avoid interference. The springs will rest on the sides of the brushes and help prevent them from sliding to the center of the cover (**Figure 12-6, Page 12-4**).
9. Install the commutator end cover (23) onto the armature shaft. Align the locating pin and hole in the cover. Install the two M6 x 180 mm bolts (20) and tighten to 100 in-lb (11.3 N·m) (**Figure 12-2, Page 12-2**).
10. Push the brushes down into the holders. Place springs into the notches in the brushes. Install the brush cover (30) that has the drain hole in it next to the A2 terminal. Install the remaining three brush covers (29) onto the openings in the commutator end cover (23) (**Figure 12-3, Page 12-2**).
11. Slide the spacer (37) onto the end of the shaft. Insert the shaft key (34) into the shaft. Install the belt pulley (39) onto the shaft and install the lockwasher (40) and M14 nut (41) and tighten the nut to 28 ft-lb (38 N·m) (**Figure 12-7, Page 12-4**).

## Starter/Generator Installation

1. Install the green wire from the F1 terminal to the A1 terminal on the starter/generator (**Figure 12-1, Page 12-1**). Install a flat washer, lockwasher, and nut onto each terminal and tighten to 48 in-lb (5.4 N·m).
2. Install two 3/8-inch hex-head pivot bolts (5) into the mounting bracket with the heads of the bolts facing towards the driver side of the vehicle. Position the starter/generator in the mounting bracket so that the bolts will go through the starter/generator before going through the bracket. Install a locknut (7) onto each bolt and tighten to finger-tight (**Figure 12-13, Page 12-10**).
3. Install the adjustment bolt (11) through the adjusting bracket (4) and then through the starter/generator. Install a lockwasher (9) and 5/16-inch nut (12) onto the end of the adjustment bolt (11) and tighten to finger-tight (**Figure 12-13, Page 12-10**).
4. Install the belt (3), then tighten the mounting bolts. **See Belt Tension Adjustment on page 12-9.**
5. Connect the yellow wire from the voltage regulator to the DF terminal on the starter/generator. Install a flat washer, lockwasher and nut onto the terminal and tighten the nut to 31 in-lb (3.5 N·m).
6. Install the white wire from the solenoid to the F2 terminal on the starter/generator. Install the black wire from the frame to the A2 terminal on the starter/generator. Install a flat washer, lockwasher and nut onto each terminal, and tighten the nut to 48 in-lb (5.4 N·m).
7. Connect battery and spark plug wire(s). **See Connecting The Battery on page 1-3.**

## Belt Tension Adjustment

Belt tension should be checked periodically. If the belt slips when starter/generator motor operates, adjust belt to correct tension.

1. Turn the key switch is OFF and remove the key. Place the Forward/Reverse handle in the NEUTRAL position. Chock the wheels.
2. Disconnect battery and spark plug wire(s). **See Disconnecting The Battery on page 1-3.**
3. Make sure the two pivot bolts (5) on the mounting bracket, carriage bolt (11) and hex nut (12) are finger-tight (**Figure 12-13, Page 12-10**).
4. Push the starter/generator down to its lowest point of adjustment travel. With the starter/generator belt in place around the drive clutch pulley, install the starter/generator belt (3).

- Place a pry bar (13) between the top of the starter/generator mounting bracket (2) and the underside of the starter/generator, by passing the pry bar under the exhaust header.

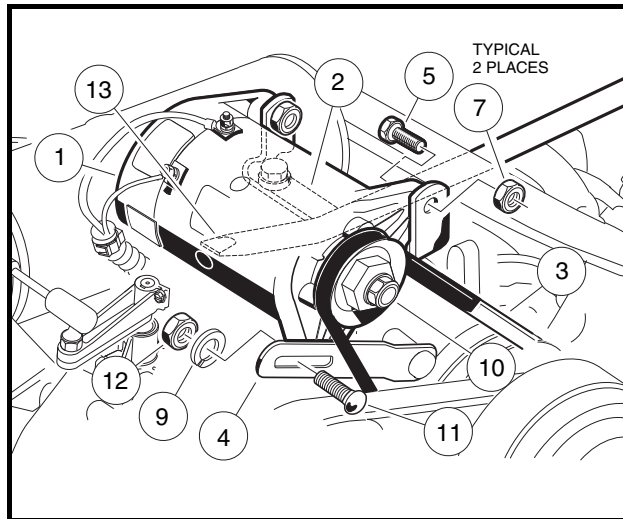


Figure 12-13 Starter/Generator Assembly

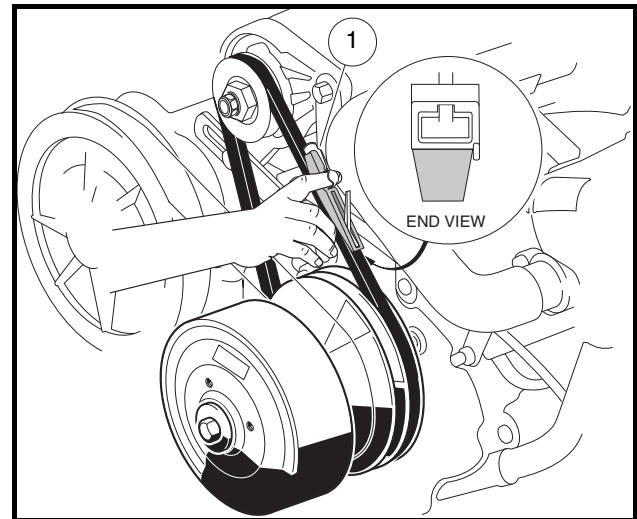


Figure 12-14 Belt Tension Gauge

- Hold the pry bar and measure the belt tension using a Krikit<sup>®</sup> gauge (1) (available at NAPA<sup>®</sup> Auto Parts stores), or equivalent. Proper tension for a new starter/generator belt should be 75 ft-lb (101.7 N·m), or 45 ft-lb (61 N·m) for an existing belt (**Figure 12-14, Page 12-10**).
- While maintaining the tension, tighten the adjustment nut (12) to 144 in-lb (16.3 N·m). Tighten the two pivot bolts (5) and hex nuts (7) to 23 ft-lb (31.2 N·m) (**Figure 12-13, Page 12-10**). **See following CAUTION.**

### **⚠ CAUTION**

- Remove pry bar before starting engine.

- Connect battery and spark plug wire(s). **See Connecting The Battery on page 1-3.**

## **STARTER/GENERATOR (MODEL 114-01-4005)**

**See General Warning, Section 1, Page 1-1.**

### **Testing the Starter/Generator**

**See Test Procedure 8, Section 11, Page 11-19. Also See Test Procedure 11, Section 11, Page 11-22.**

### **Starter/Generator Removal**

- Disconnect battery and spark plug wire(s). **See Disconnecting The Battery on page 1-3.**
- Remove the access panel on the vehicle.

3. Mark and disconnect the wires from the starter/generator (1). Loosen the two pivot nuts (7) and bolts (5) (Figure 12-15, Page 12-11).

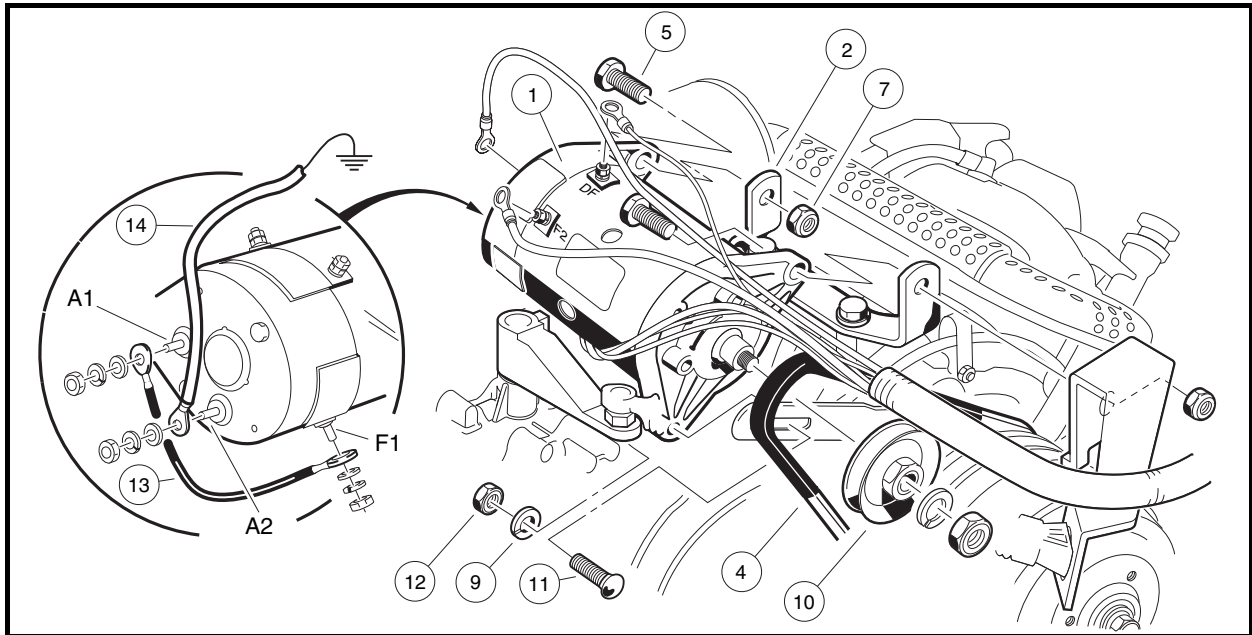


Figure 12-15 Starter/Generator Removal

4. Remove the mounting/adjustment nut (12), washer (9) and bolt (11). Lower the starter/generator and remove the belt (4) from the pulley (10).
5. Support the starter/generator so that when the pivot bolts are removed the starter/generator will not fall to the ground. Remove the two pivot nuts (7) and bolts (5) from the mounting bracket.
6. Remove the starter/generator.

### Disassembly of the Starter/Generator to Service the Brushes

1. Remove brush covers (29 and 30). (Figure 12-17, Page 12-12). Pull back each brush spring and pull the brushes back from the center of the commutator end cover. The springs will rest on the sides of the brushes and help prevent them from sliding towards the center of the cover. (Figure 12-20, Page 12-14). See following NOTE.

**NOTE:** If the brushes are not removed, contact between the brushes and commutator as the commutator end cover is being removed or installed could damage the brushes.

2. Remove the two bolts (20) and pull commutator end cover (23) free of starter/generator housing (24) (Figure 12-16, Page 12-12).
3. Remove terminal hardware (31), screws and lock washers (25), brush holder assembly (26), brush springs (28), and brushes (27). Make note of the routing of the brushes and wires between the brush holder assembly and the inside of the commutator end cover for later reassembly (Figure 12-17, Page 12-12). See following NOTE.

**NOTE:** Clean and inspect the armature/commutator and the bearings. See **Disassembly of the Starter/Generator to Service the Armature/Commutator on page 12-14.**

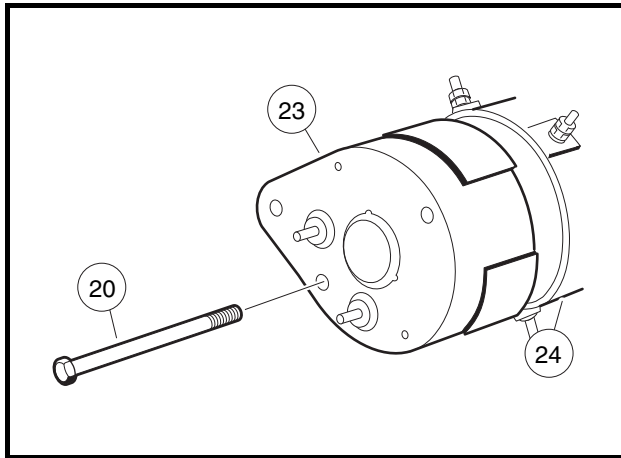


Figure 12-16 Commutator End Cover

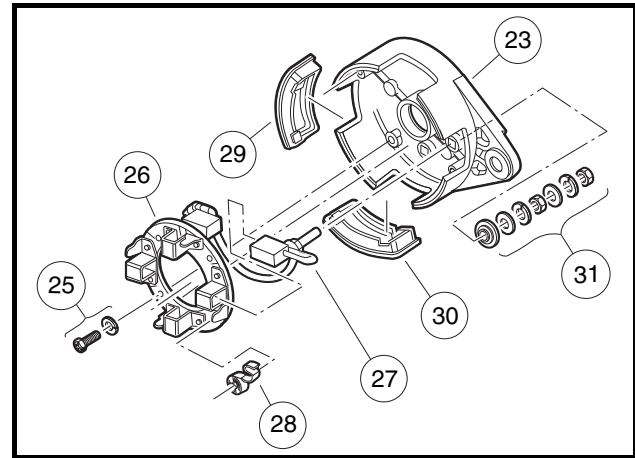


Figure 12-17 Brush Covers and Brushes

## Brush Inspection and Replacement

1. Visually inspect brushes. Replace brushes that are cracked or severely chipped.
2. Check the length of each brush. If the overall length of any brush is less than 0.79 inch (20 mm), replace all four brushes (**Figure 12-18, Page 12-12**).

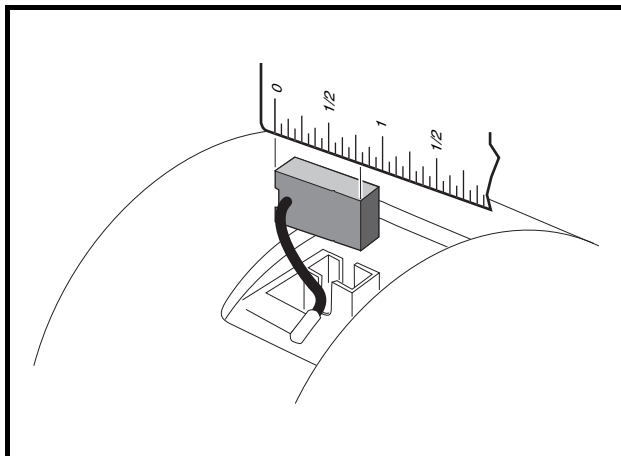


Figure 12-18 Inspect Brushes

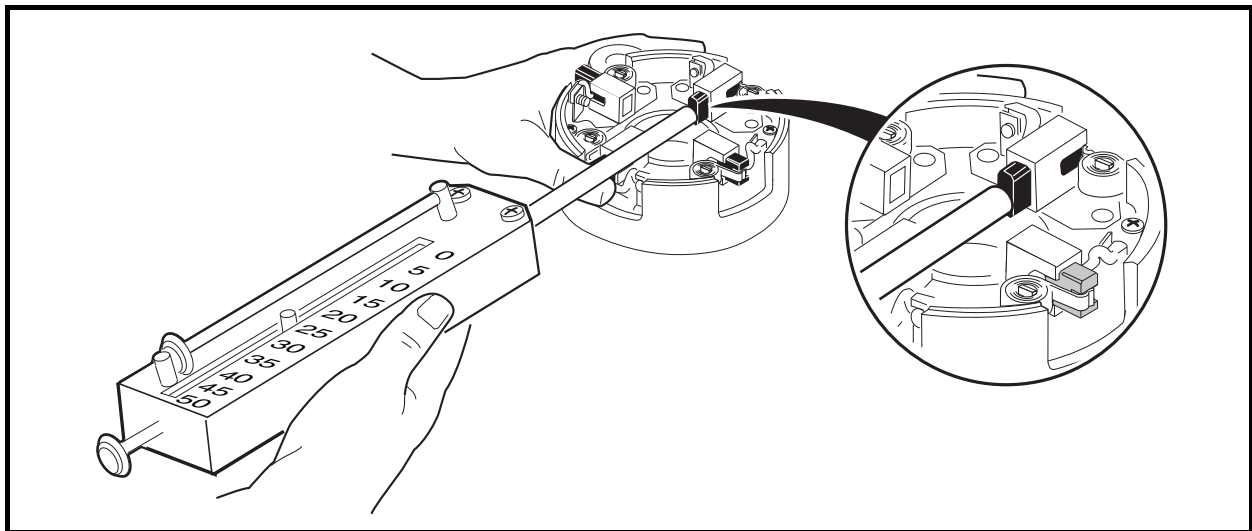
## Brush Spring Inspection and Replacement

1. Visually inspect springs. Replace all four springs if any spring is discolored from heat (straw or bluish in color).

2. Install the four brushes (27) into their holders and insert the four brush springs (28) (**Figure 12-17, Page 12-12**). Insert the brush wiring terminal studs through the commutator end cover (23) and assemble using the terminal hardware (31). Route the brush wiring between the brush holder assembly (26) and the inside of the commutator end cover (23) and assemble using the screws and lock washers (25). Using a spring scale, test brush spring tension. If any spring has a tension less than 14.8 ounces (4.1 N), replace all four springs (**Figure 12-19, Page 12-13**). See following **CAUTION**.

### **▲ CAUTION**

- When checking brush spring tension, do not push springs beyond the point they would normally be if there were new brushes installed. Exerting excessive force or pushing brush springs beyond their normal maximum extension point will damage springs.



**Figure 12-19 Brush Spring Tension Test**

### **Starter/Generator Assembly**

1. To prevent contact between the brushes and commutator as the commutator is installed, and possible damage to the brushes, pull back each brush spring and pull the brushes back from the center of the commutator end cover. The springs will rest on the sides of the brushes and help prevent them from sliding towards the center of the cover (**Figure 12-20, Page 12-14**).
2. Install the commutator end cover (23) onto the armature shaft. Orient the commutator end cover with the field coil housing as shown. Install two M5 x 20 mm bolts (20) and tighten to 60 in-lb (6.8 N·m) (**Figure 12-16, Page 12-12**).
3. Push the brushes down into the holders. Position springs so that brushes are being held against the commutator. Install the brush cover (30) that has the drain hole in it next to the A2 terminal. Install the remaining three brush covers (29) in the openings in the commutator end cover (23) (**Figure 12-17, Page 12-12**).

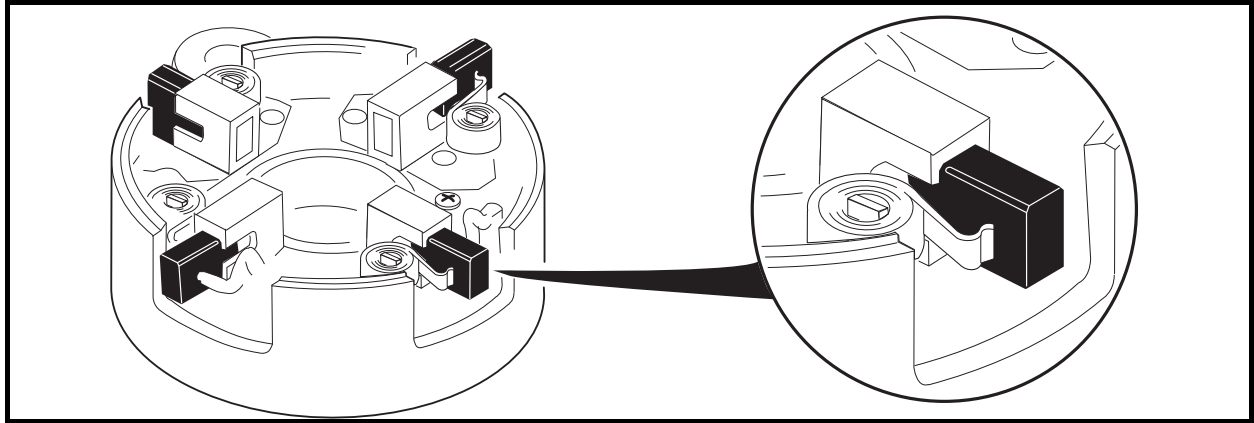


Figure 12-20 Pull Brushes Away from Center of the Commutator End Cover

### Disassembly of the Starter/Generator to Service the Armature/Commutator

1. Remove the commutator end cover to prevent damage to the brushes and armature. **See *Disassembly of the Starter/Generator to Service the Brushes on page 12-11.***
2. To separate armature and output end cover assembly from the field coil housing, first remove the two securing bolts (43). Carefully remove armature and output end cover assembly from the field coil housing so components are not damaged.
3. To separate armature (33) from output end cover (36), remove nut (41), lock washer (40), pulley (39). It may be necessary to use the wedge attachment tool (CCI P/N 1012812) to remove the pulley from the shaft.
4. Remove the internal retaining ring (32) to release the bearing (35) and armature (33) from the output end cover (36). (**Figure 12-21, Page 12-14.**)

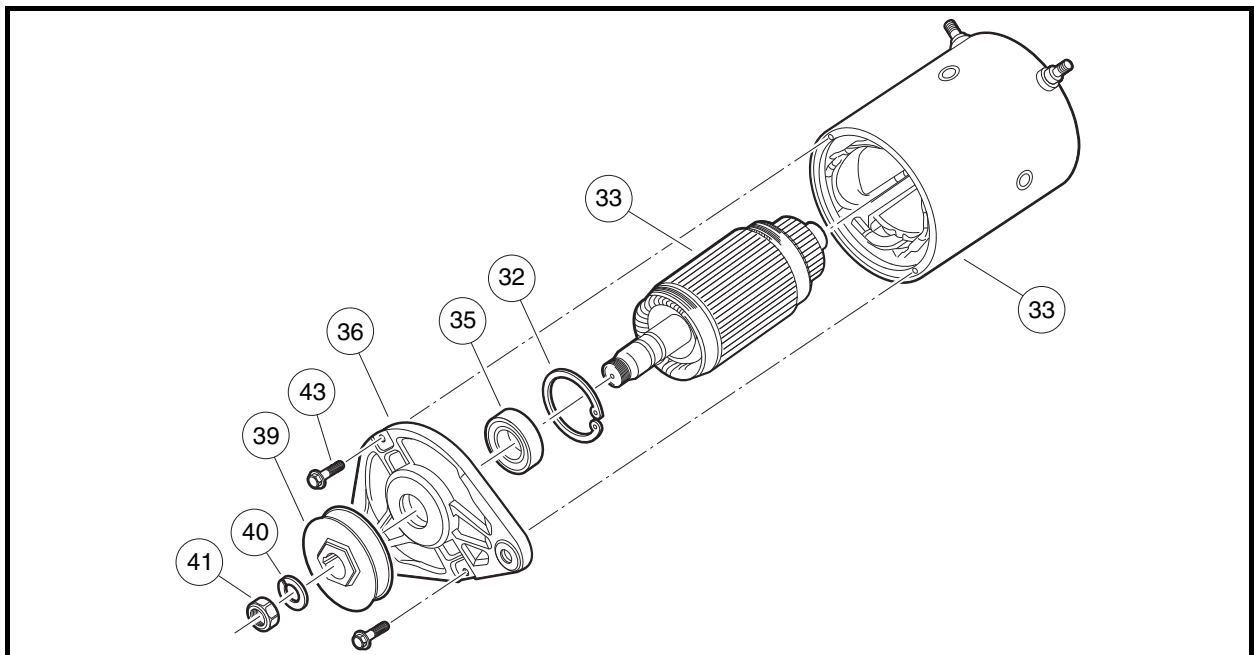
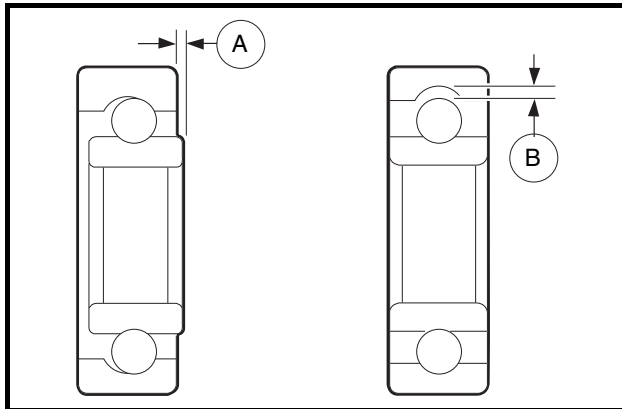


Figure 12-21 Output End Cover Assembly, Armature and Housing



## Bearing Cleaning and Inspection

- Using a clean cloth, wipe the carbon dust from the two bearings. Inspect bearings by spinning them by hand and checking for both axial (A) and radial (B) play (**Figure 12-22, Page 12-15**).

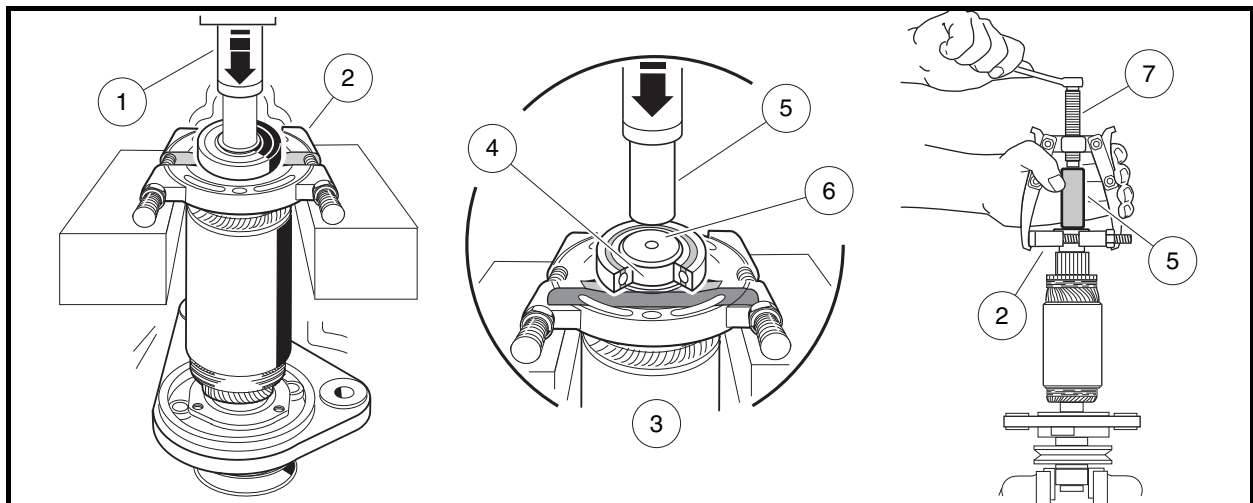


**Figure 12-22 Bearing Play Inspection**

- Replace the bearing if it is noisy, does not spin smoothly, or has excessive play. Check the bearings and replace if rusted, worn, cracked, or if there is an abnormal color change in the metal of the bearing. Bearings should be replaced if there is extensive wear or pitting on the balls or on the rolling surfaces. Do not remove the bearings unless they are to be replaced.

## Bearing Removal

- Place the wedge attachment tool (CCI P/N 1012812) between the bearing and the armature. Make sure the wedge attachment tool is supporting the inner race of the bearing. If a press is not available, secure a bearing puller (CCI P/N 1012811) to the wedge attachment tool and pull the bearing off of the end of the armature shaft. Support the armature so that it will not drop when the bearing is removed (**Figure 12-23, Page 12-15**).
- Slide the bearing retainer ring (32) off of the output end of the shaft (**Figure 12-21, Page 12-14**).



**Figure 12-23 Bearing Removal**

- Press Ram
- Wedge Attachment Tool
- Bearing sectioned for clarity
- Support inner race of bearing
- Use a 1/2 inch socket or pipe
- Press against armature shaft
- Use bearing puller if a press is not available

## Field Coil Assembly

1. Replace entire field coil housing assembly if coils, pole shoes or terminals are damaged. (**Figure 12-24, Page 12-16**).

## Visual Inspection of Armature

Obvious defects can be seen by examining the armature. If an armature has frayed or charred insulation, broken wires or thrown solder, it is obvious without testing that it should be replaced. Faults seen during the visual inspection can aid in diagnosing the original cause of the failure. Items to look for are listed below.

- Burned, charred, or cracked insulation
- Improperly cured varnish
- Thrown solder
- Flared armature windings
- Worn, burned, or glazed commutator
- Loose or raised commutator bars
- Bruised or damaged armature core laminations
- Worn armature bearing or shaft
- Dirty or oily commutator

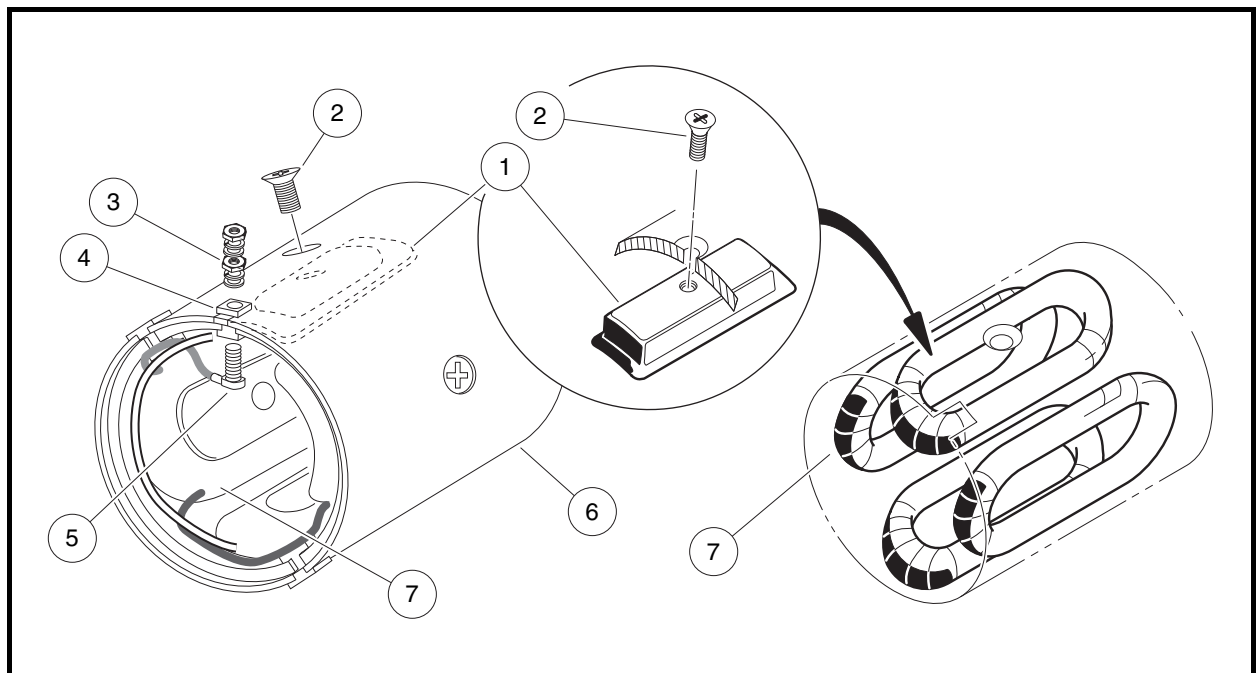


Figure 12-24 Field Coil Assembly

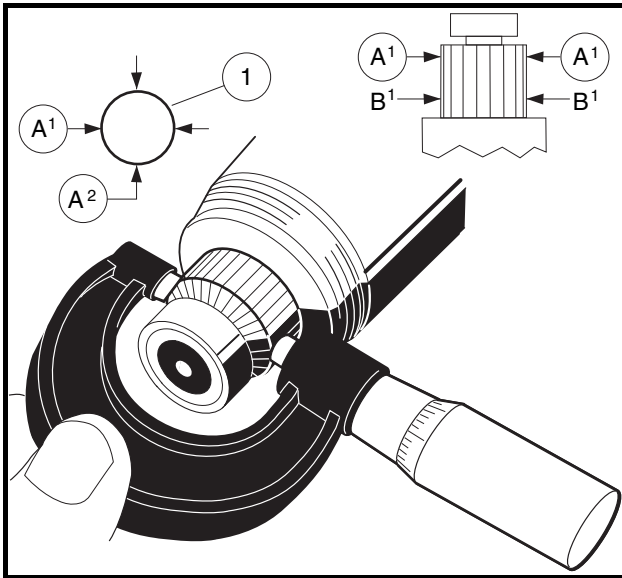
## Commutator Cleaning and Inspection

1. Clean the carbon dust, dirt and oil from the commutator. Visually inspect the commutator for worn, burned or glazed areas. Check for loose or raised commutator bars. Slight roughness of the commutator can be polished away with 400 grit (or finer) sandpaper. **See following CAUTION.**

**⚠ CAUTION**

- Do not use emery cloth on the commutator. Particles of emery are conductive and may short-circuit the commutator bars. Do not use oil or lubricants on the commutator or brushes.

2. Using a micrometer, measure the outside diameter at two points along the commutator. If the commutator outside diameter is less than 1.60 inches (40.6 mm), replace the armature and bearings (Figure 12-25, Page 12-17).



**Figure 12-25 Inspect Commutator**

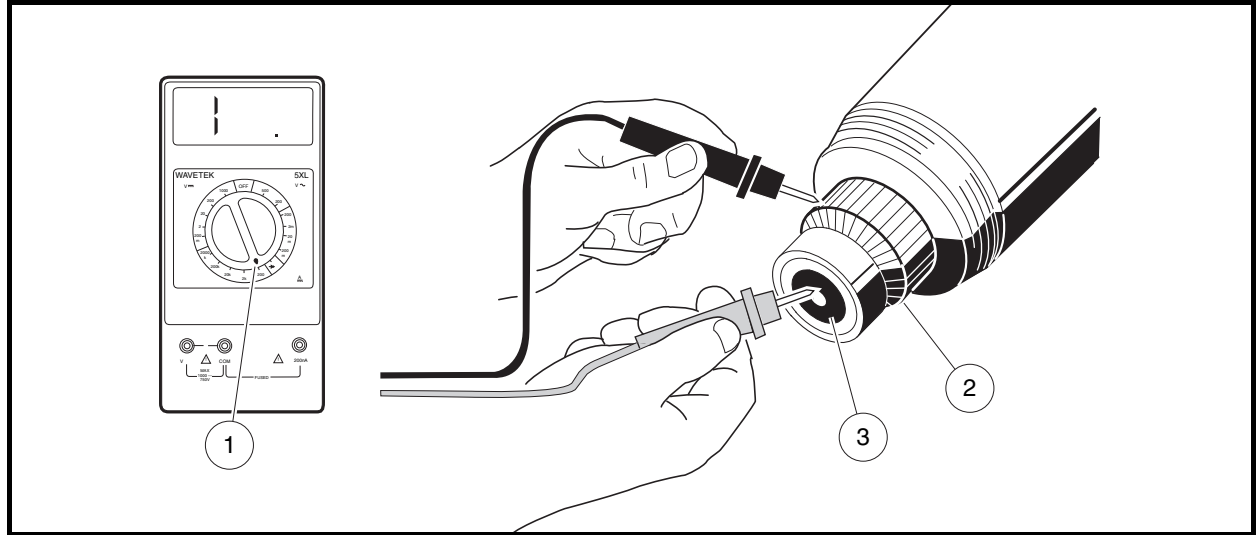
1. Measure each position in two places, 90 degrees apart

**Armature Ground Test****⚠ CAUTION**

- Do not submerge armature in solvent.

**NOTE:** Before testing, wipe the armature with a clean cloth and remove carbon dust and metal particles from between commutator bars.

1. Using a multimeter set on 200 (ohms), place the positive (+) probe on the commutator bars and the negative (–) probe on the armature core. The reading should be no continuity. If the reading is incorrect, replace the armature and the two bearings (Figure 12-26, Page 12-18).



**Figure 12-26 Armature Ground Test**

1. 200 Ohms Setting 2. Commutator 3. Armature Shaft

## Visual Inspection of Field Coils

If the insulation on the field coils appears blackened or charred, the serviceability of the coils is questionable. Burned or scorched coil insulation indicates the starter/generator has overheated due to overloads or grounded or shorted coil windings. Be sure the insulators are tight in the housing.

## Starter/Generator Rework

Any rework must be performed by a qualified technician. Starter/generator service specifications are listed in the following table.

ITEM	SERVICE LIMIT
Commutator diameter (minimum)	1.60 in. (41 mm)
Concentric with armature shaft within	0.002 in. (0.051 mm)
Minimum commutator diameter for reslotting	1.65 in. (42 mm)
Undercut (Commutator must have a minimum diameter of 1.65 in (42 mm) for reslotting):	0.050 in. (1.3 mm)
Dielectric strength	500 VAC for one minute
Armature insulation resistance	0.2M (ohms) at 500 VDC
Starter field coil resistance	0.006-0.01 (ohms)
Generator field coil resistance	4.5-5.5 (ohms)

## Starter/Generator Assembly

1. Slide the bearing retainer (32) onto the output end of the armature shaft (33) (**Figure 12-21, Page 12-14**).

2. Press a new ball bearing (35) onto the output end of the armature (**Figure 12-21, Page 12-14**). Press a new ball bearing onto the commutator end of the armature shaft. **See following CAUTION.**

### **⚠ CAUTION**

- To prevent damage to the retainer, use care while pressing new bearing onto the output end of the shaft.
  - Press against the inner race of the new bearing until it is fully seated.
3. Install the drive end cover (36) onto the armature. Secure the bearing retainer ring (32) (**Figure 12-21, Page 12-14**).
  4. Slide the housing with field coils over the armature. Use the tapped mounting holes to align housing to the cover, rotate and orient as shown.

**NOTE:** The terminal insulators should be on the commutator end of the housing.

5. To prevent contact between the brushes and commutator as the commutator cover is installed, and possible damage to the brushes, lift the brush springs out of the notches in the brushes and pull the brushes back from the center of the commutator end cover. The springs will rest on the sides of the brushes and help prevent them from sliding towards the center of the cover (**Figure 12-20, Page 12-14**).
6. Install the commutator end cover (23) onto the armature shaft. Use the tapped mounting holes to align housing to the cover, rotate and orient as shown. Install the two M6 x 180 mm bolts (20), and tighten to 60 in-lb (6.8 N·m) (**Figure 12-16, Page 12-12**).
7. Push the brushes down into the holders. Place springs into the notches in the brushes. Install the brush cover (30) that has the drain hole in it next to the A2 terminal. Install the remaining three brush covers (29) in the openings in the commutator end cover (23) (**Figure 12-17, Page 12-12**).
8. Install the belt pulley (39) onto the shaft, and install the lock washer (40) and M14 nut (41). Tighten the nut to 30 ft-lb (40.7 N·m) (**Figure 12-21, Page 12-14**).

## **Starter/Generator Installation**

1. Install the green wire from the F1 terminal to the A1 terminal on the starter/generator (**Figure 12-15, Page 12-11**). Install a flat washer, lock washer, and nut onto each terminal and tighten to 48 in-lb (5.4 N·m).
2. Install two 3/8-inch hex-head pivot bolts (5) into the mounting bracket with the heads of the bolts facing toward the driver-side of the vehicle. Position the starter/generator in the mounting bracket so that the bolts will go through the starter/generator before going through the bracket. Install a lock nut (7) onto each bolt. Tighten to finger tight (**Figure 12-27, Page 12-20**).
3. Install the adjustment bolt (11) through the adjusting bracket (4) and then through the starter/generator. Install a lock washer (9) and 5/16-inch nut (12) onto the end of the adjustment bolt (11). Tighten to finger tight.
4. Install the belt (3), then tighten the mounting bolts. **See Belt Tension Adjustment on page 12-20.**
5. Connect the yellow wire from the voltage regulator to the DF terminal on the starter/generator. Install a flat washer, lock washer, and nut onto the terminal. Tighten the nut to 18 in-lb (2.0 N·m).
6. Install the white wire from the solenoid to the F2 terminal on the starter/generator. Install the black wire from the frame to the A2 terminal on the starter/generator. Install a flat washer, lock washer and nut onto each terminal, and tighten the nut to 45 in-lb (5.1 N·m). Bundle and tie wrap excess wire.

7. Connect battery and spark plug wire(s). **See Connecting The Battery on page 1-3.**

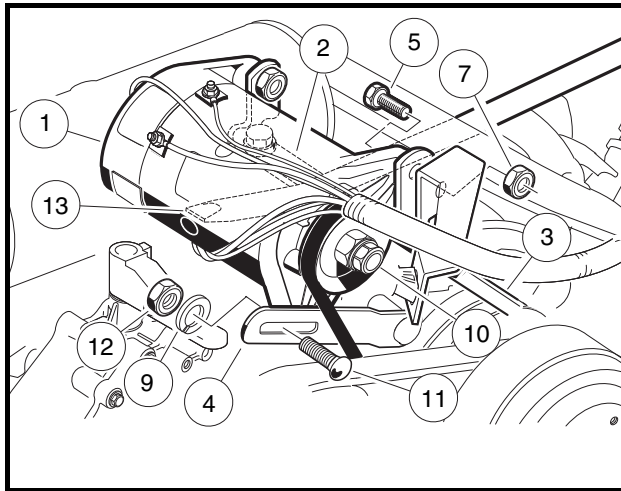


Figure 12-27 Starter/Generator Installation

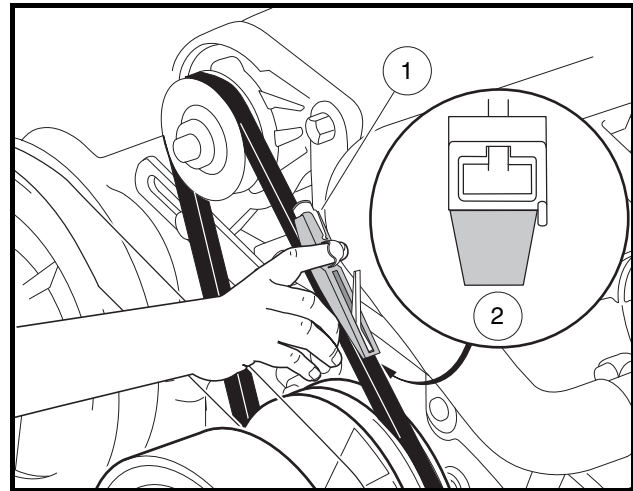


Figure 12-28 Belt Tension Gauge

1. Belt Tension Gauge 2. End View

## Belt Tension Adjustment

Belt tension should be checked periodically. If the belt slips when starter/generator motor operates, adjust belt to correct tension.

1. Disconnect battery and spark plug wire(s). **See Disconnecting The Battery on page 1-3.**
2. Remove the access panel on the vehicle.
3. Make sure the two pivot bolts (5) on the mounting bracket are finger tight. The carriage bolt (11) and hex nut (12) are to be finger tight also (**Figure 12-27, Page 12-20**).
4. Push the starter/generator down so it is at the lowest point of its adjustment travel. With the starter/generator belt in place around the drive clutch pulley, install the starter/generator belt (3) around the pulley (10) on the end of the starter/generator.
5. Position a pry bar (13) between the top of the starter/generator mounting bracket (2) and the underside of the starter/generator by passing the pry bar under the exhaust header.
6. While holding the pry bar, measure the belt tension using a Krikit<sup>®</sup> gauge (1) (available at NAPA<sup>®</sup> Auto Parts stores), or equivalent. Proper tension for a new starter/generator belt should be 120 lb (534 N) or 70 lb (311 N) for an existing belt (**Figure 12-28, Page 12-20**).
7. While maintaining the tension, tighten the adjustment nut (12) to 144 in-lb (16.3 N·m). Tighten the two pivot bolts (5) and hex nuts (7) to 23 ft-lb (31.2 N·m) (**Figure 12-27, Page 12-20**). **See following CAUTION.**

### **⚠ CAUTION**

- Remove pry bar before starting engine.

8. Connect battery and spark plug wire(s). **See Connecting The Battery on page 1-3.**

## VOLTAGE REGULATOR

See **General Warning, Section 1, Page 1-1.**

### Testing the Voltage Regulator

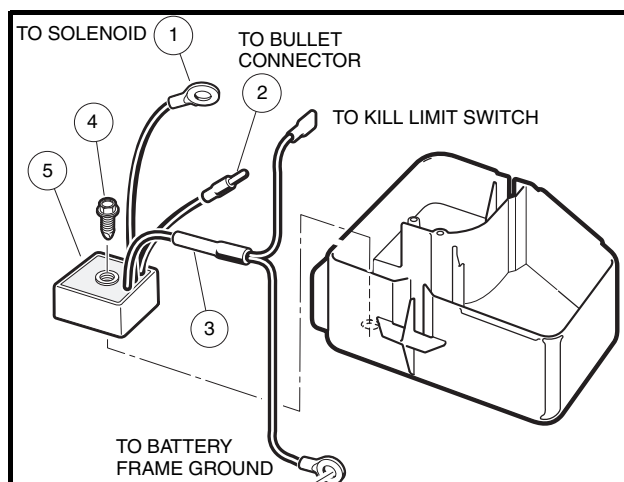
See **Test Procedure 12, Section 11, Page 11-22.**

### Voltage Regulator Removal

1. Disconnect battery and spark plug wire(s). **See Disconnecting The Battery on page 1-3.**
2. Remove the air intake hose from the carburetor.
3. Remove the electrical component box cover.
4. Disconnect the voltage regulator red wire (1) at the large post on the solenoid, the yellow wire (4) at the bullet connector and the black wire (7) from the wire harness and at the battery frame ground (**Figure 12-29, Page 12-21**).
5. Remove the voltage regulator mounting screw (8) and remove the voltage regulator (9).

### Voltage Regulator Installation

1. Position the voltage regulator (9) in the electrical component box and install the mounting screw (8) and tighten screw to 23 in-lb (2.6 N·m) (**Figure 12-29, Page 12-21**).
2. Connect the voltage regulator red wire (1) at the large post on the solenoid with the other red wires, the yellow wire (4) at the bullet connector and the black wire (7) to the wire harness and the battery frame ground (**Figure 12-29, Page 12-21**).
3. Install electrical component box cover. Be sure to firmly press down all corners. Install screw and tighten to 18 in-lb (2 N·m).
4. Install the air intake hose onto the carburetor.
5. Connect battery and spark plug wire(s). **See Connecting The Battery on page 1-3.**
6. With the Forward/Reverse handle in the NEUTRAL position, start the engine and check regulator for proper functioning as described in the voltage regulator test procedure. **See Test Procedure 12, Section 11, Page 11-22.**



**Figure 12-29 Voltage Regulator**

## DIODE

See General Warning, Section 1, Page 1-1.

### Testing the Diode

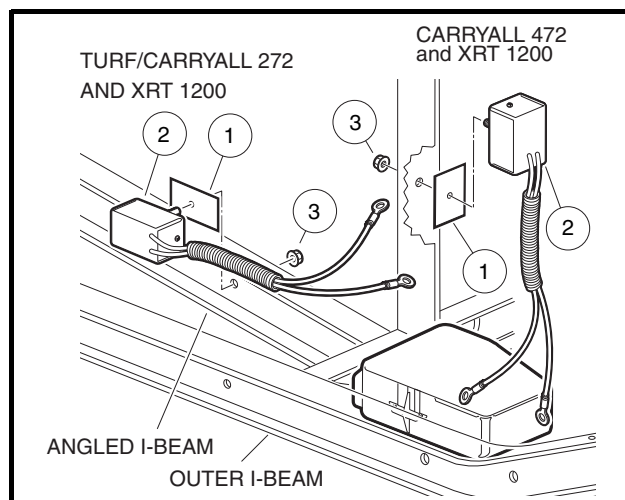
See Test Procedure 10, Section 11, Page 11-20.

### Diode Removal

1. Turn the key switch OFF and remove the key. Place the Forward/Reverse handle in the NEUTRAL position. Chock the wheels.
2. Disconnect battery and spark plug wire(s). **See Disconnecting The Battery on page 1-3.**
3. Remove the carburetor air intake hose to allow easy access to the electrical component box cover.
4. Remove the cover screw (5) and electrical component box cover (6) (**Figure 12-31, Page 12-23**).
5. Remove the nuts (7) from the two large solenoid posts and disconnect the diode wires from the solenoid.
  - 5.1. Observe color orientation of the wires with the terminal locations on the solenoid. The 12-gauge red wire from the diode should be attached to the same terminal as the red wire from the fuse block, and the red wire from the battery. The 12-gauge white wire should be attached to the other large solenoid post, along with the red wire from the voltage regulator and the white wire from the starter/generator.
6. Remove the nut (3) and remove the diode (2) and thermal transfer pad (1) from the vehicle frame (**Figure 12-30, Page 12-22**).

### Diode Installation

1. Thoroughly clean and dry the area of the I-beam where the new diode is to be attached.
2. Peel the protective film from both sides of the new thermal pad (1) (**Figure 12-31, Page 12-23**). **See following CAUTION.**



**Figure 12-30** Location of Diodes



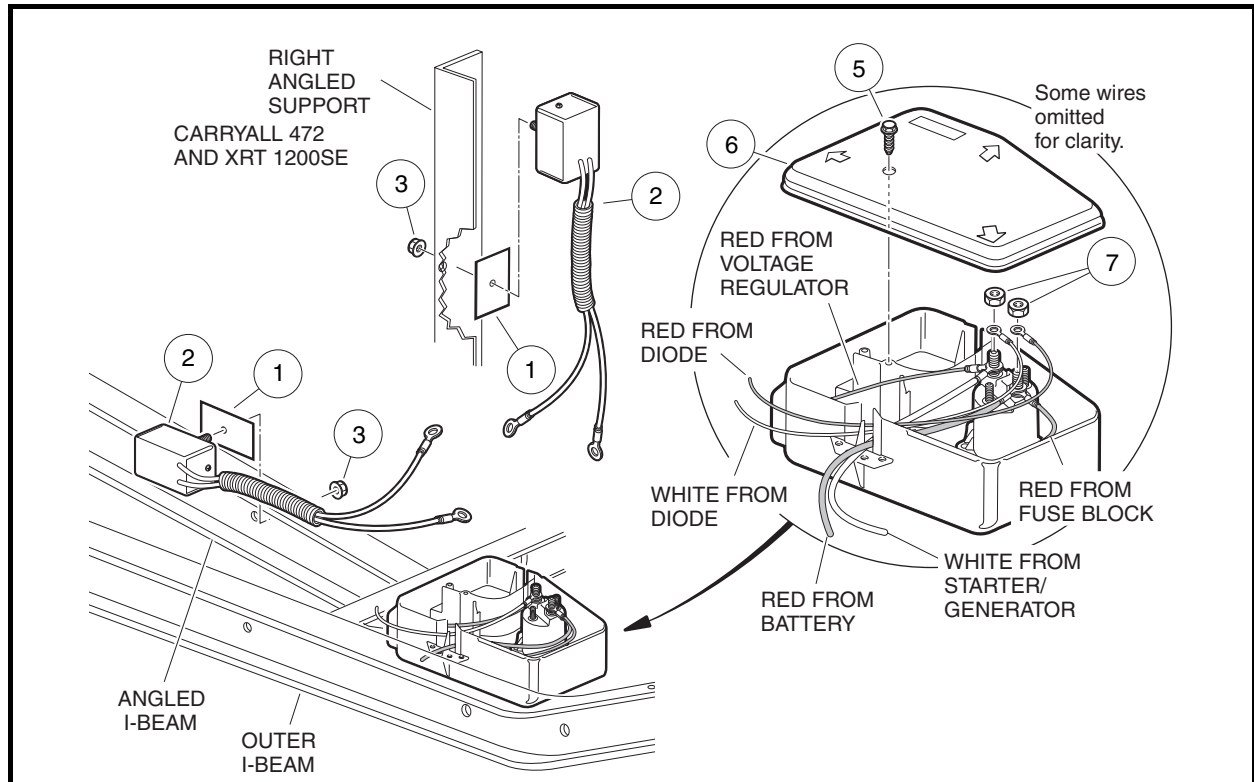


Figure 12-31 Electrical Component Box and Diode Orientation

## CAUTION

- Be sure to remove and discard the protective film from both sides of the thermal pad before installing it. If not removed, the film will reduce the thermal heat transfer and therefore reduce the power handling capability of the diode, causing it to overheat and damage the electrical system.

3. Mount the diode (2) using the thermal transfer pad (1) and mounting nut (3) and tighten to 25 in-lb (2.8 N·m) (Figure 12-31, Page 12-23). See following NOTE.

**NOTE:** Diodes are mounted in one of two different locations, depending on the vehicle model (Figure 12-30, Page 12-22).

4. Route and connect the red and white diode wires to the solenoid posts in the electrical component box. See following WARNING.

## ⚠ WARNING

- Incorrect wiring could result in severe injury or death.
  - Diode and solenoid connections must have correct polarity.
  - Keep all persons clear of engine belts when making final connections.
- 4.1. Connect the 12-gauge red wire from the diode to the solenoid post with the fuse block and battery red wires and tighten locknut (7) to 55 in-lb (6.2 N·m) (Figure 12-31, Page 12-23).
  - 4.2. Connect the 12-gauge white wire to the other large solenoid post, along with the red wire from the voltage regulator and white wire from the starter/generator and tighten nut (7) to 55 in-lb (6.2 N·m).

5. Replace the electrical component box cover (6) and screw (5) and tighten the screw to 18 in-lb (2.0 N·m).
6. Connect the intake hose to the carburetor and secure the hose with the hose clamp.
7. Connect battery and spark plug wire(s). **See Connecting The Battery on page 1-3.**

## KEY SWITCH

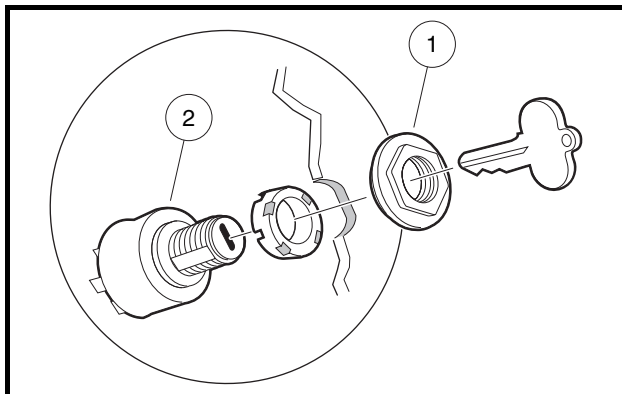
**See General Warning, Section 1, Page 1-1.**

### Testing the Key Switch

**See Test Procedure 4, Section 11, Page 11-15. Also see Test Procedure 17 – Key Switch (Engine Kill Circuit) on page 11-30.**

### Key Switch Removal

1. Turn the key switch OFF and remove the key. Place the Forward/Reverse handle in the NEUTRAL position. Chock the wheels.
2. Disconnect battery and spark plug wire(s). **See Disconnecting The Battery on page 1-3.**
3. Remove the dash panel.
  - 3.1. Loosen seven Tuflok screws, but do not remove screws completely, as shown in Detail A (**Figure 12-33, Page 12-25**).
  - 3.2. Remove Tuflok screws from dash panel as shown in Detail B.
  - 3.3. Pull forward on top of dash panel to access back side of key switch.
  - 3.4. Disconnect the wire connector from the key switch.
4. Remove the key switch.
  - 4.1. Remove the key switch nut (1) (**Figure 12-32, Page 12-24**).
  - 4.2. Remove key switch (2) from back side of dash panel.



**Figure 12-32 Key Switch Removal**

### Key Switch Installation

1. Install the key switch in the dash in reverse order of removal. Tighten the key switch nut firmly. Reconnect the wire connector to the key switch.
2. Install the dash in reverse order of removal. **See Key Switch Removal on page 12-24.**
3. Connect battery and spark plug wire(s). **See Connecting The Battery on page 1-3.**

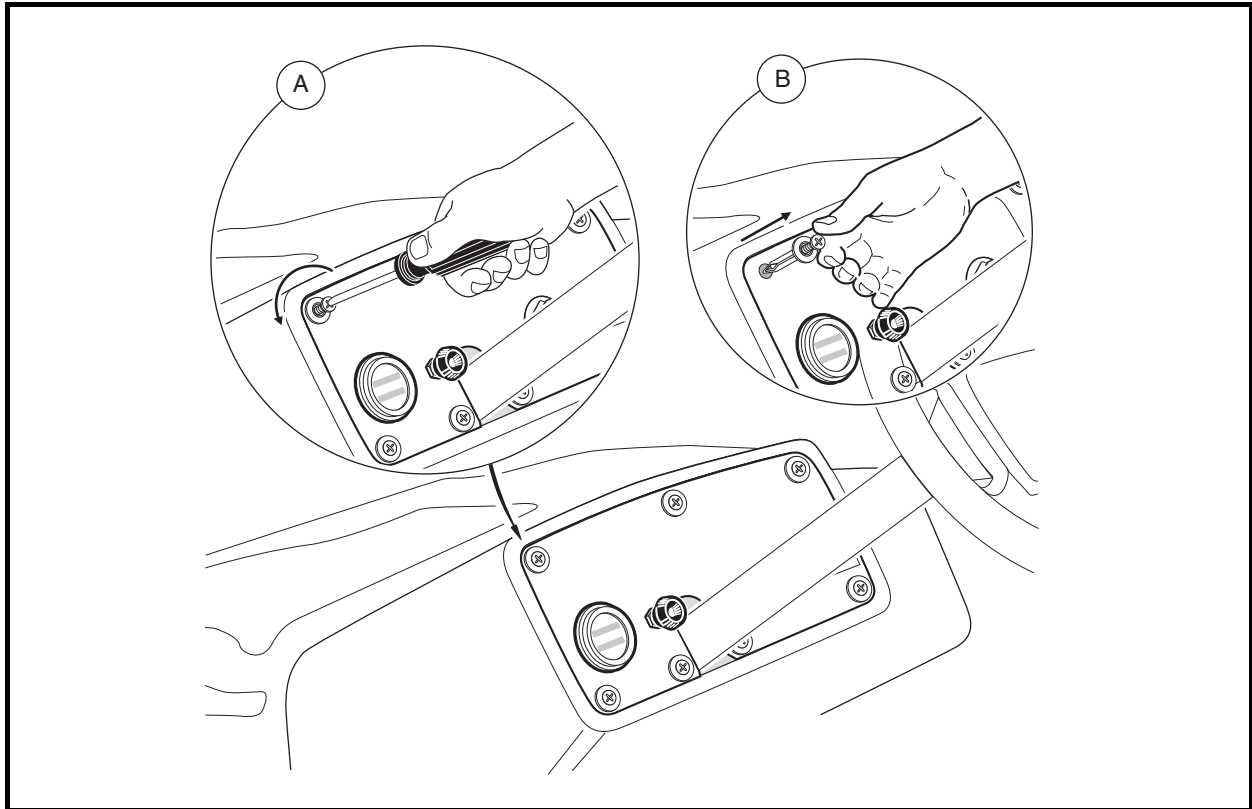


Figure 12-33 Center Dash Panel Removal

## SOLENOID

See General Warning, Section 1, Page 1-1.

### Testing the Solenoid

See Test Procedure 6, Section 11, Page 11-17.

### Solenoid Removal

1. Turn the key switch OFF and remove the key. Place the Forward/Reverse handle in the NEUTRAL position. Chock the wheels.
2. Disconnect battery and spark plug wire(s). **See Disconnecting The Battery on page 1-3.**
3. Remove the air intake hose from the carburetor.
4. Remove electrical component box cover.
5. Disconnect all the wires from the solenoid.
6. Remove the two screws securing the solenoid in place.

### Solenoid Installation

1. Install the solenoid in the electrical component box using two screws to secure the solenoid to the box and tighten to 14 in-lb (1.6 N·m). **See following WARNING.**

## **⚠ WARNING**

- **Incorrect wiring could result in severe injury or death.**
  - **Diode and solenoid connections must have correct polarity.**
  - **Keep all persons clear of engine belts when making final connections.**
2. Connect all wires as indicated.
    - 2.1. Connect the 6-gauge white wire from the starter/generator, 18-gauge red wire from the voltage regulator, and the 12-gauge white wire from the diode to the large post on the solenoid. **See Wiring Diagrams, Section 11, Page 11-6.**
    - 2.2. Connect the 6-gauge red wire from the battery, the 10-gauge red wire from the fuse block, and the 12-gauge red wire from the diode to the other large post on the solenoid.
    - 2.3. Connect the 18-gauge blue wire from the key switch to the small post on the solenoid.
    - 2.4. Connect the 18-gauge green wire from the Forward/Reverse limit switch to the other small post on the solenoid.
  3. Tighten the hex nuts on the large solenoid posts to 55 in-lb (6.2 N·m). Tighten the nuts on the small solenoid posts to 22 in-lb (2.5 N·m).
  4. Install the snap-on electrical box cover by firmly pressing down on all corners and install the screw and tighten to 18 in-lb (2 N·m).
  5. Install the air intake hose onto the carburetor.
  6. Connect battery and spark plug wire(s). **See Connecting The Battery on page 1-3.**

## **FUSE**

**General Warning, Section 1, Page 1-1.**

### **Testing the Fuse**

**See Test Procedure 2, Section 11, Page 11-13.**

### **Fuse Removal**

1. Turn the key switch OFF and remove the key. Place the Forward/Reverse handle in the NEUTRAL position. Chock the wheels.
2. Disconnect battery and spark plug wire(s). **See Disconnecting The Battery on page 1-3.**
3. Remove the air intake hose from the carburetor.
4. Remove electrical component box cover.
5. Remove the fuse from the fuse block.

### **Fuse Installation**

1. Install the fuse. **See following WARNING.**

## **⚠ WARNING**

- **If a fuse is blown, determine the cause of the failure and make necessary repairs before installing a new fuse. Use the appropriately rated fuse; if a fuse with a higher amp rating is used, damage to the vehicle electrical system may occur.**

2. Install the snap-on electrical box cover by firmly pressing down on all corners and install the screw and tighten to 18 in-lb (2 N·m).
3. Install the air intake hose onto the carburetor.
4. Connect battery and spark plug wire(s). **See Connecting The Battery on page 1-3.**

## LOCKOUT CAM LIMIT SWITCH

---

**See General Warning, Section 1, Page 1-1.**

### Testing the Lockout Cam Limit Switch

**See Test Procedure 7, Section 11, Page 11-17.**

### Lockout Cam Limit Switch Removal

1. Turn the key switch OFF and remove the key. Place the Forward/Reverse handle in the NEUTRAL position. Chock the wheels.
2. Disconnect battery and spark plug wire(s). **See Disconnecting The Battery on page 1-3.**
3. Disconnect the wires from the lockout cam limit switch (5) located on the back of the Forward/Reverse shifter assembly (**Figure 12-34, Page 12-28**).
4. Remove two nuts (2) and washers (6) from the lockout cam limit switch (5) and slide the lockout cam limit switch off of the screws.

### Lockout Cam Limit Switch Installation

1. Install the limit switch (5) with washers (6) and nuts (2) and tighten to 5 in-lb (0.6 N·m) (**Figure 12-34, Page 12-28**). Place the Forward/Reverse handle in REVERSE to make sure that both switches actuate. **See following CAUTION.**

#### **⚠ CAUTION**

- **Do not overtighten the retaining nuts. If the nuts are overtightened, limit switches could be damaged.**
2. Connect the black wire to the common (COM) terminal and the green wire to the normally open (NO) terminal of the lockout cam limit switch. **See Wiring Diagrams, Section 11, Page 11-6.**
  3. Connect battery and spark plug wire(s). **See Connecting The Battery on page 1-3.**
  4. With the Forward/Reverse handle in the NEUTRAL position, the lockout cam should be activating the lockout cam limit switch. Make sure everyone is clear of the vehicle.
  5. Turn the key switch to the START position. The engine should crank only when the Forward/Reverse handle is in the NEUTRAL position.
  6. Test drive the vehicle in both forward and reverse for proper operation.

## LOCKOUT CAM

See General Warning, Section 1, Page 1-1.

If the cam lobes have worn to the point where they will no longer actuate the lockout cam limit switch, the cam must be replaced.

### Testing the Lockout Cam

See Test Procedure 23, Section 11, Page 11-32.

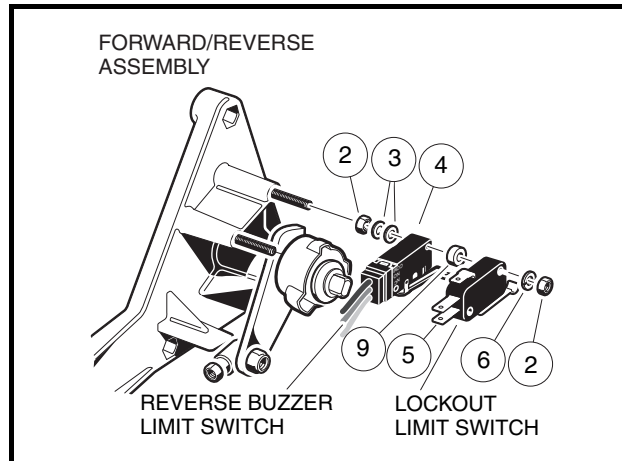


Figure 12-34 Lockout Cam and Reverse Buzzer Limit Switches

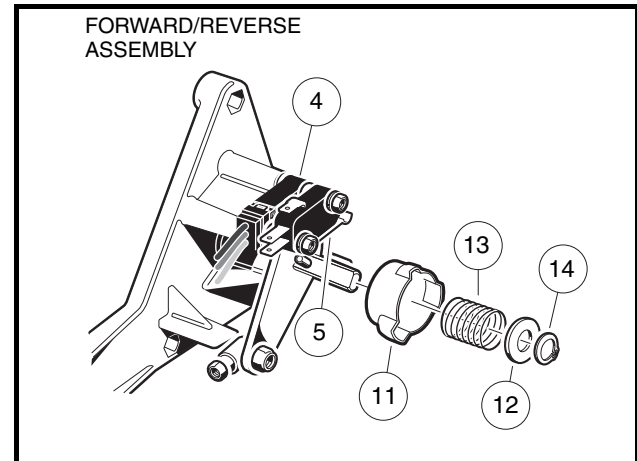


Figure 12-35 Lockout Cam

### Lockout Cam Removal

1. Turn the key switch OFF and remove the key. Place the Forward/Reverse handle in the NEUTRAL position. Disconnect battery and spark plug wire(s). **See Disconnecting The Battery on page 1-3.**
2. Remove the external snap ring (14) (**Figure 12-35, Page 12-28**).
3. Remove the plastic washer (12) and the spring (13).
4. Remove the cam (11).

### Lockout Cam Installation

1. Install the cam (11) (**Figure 12-35, Page 12-28**).
2. Install the spring (13) and the plastic washer (12).
3. Install the external snap ring (14) into the groove on the shaft. The lockout limit switch should be activated only when the Forward/Reverse handle is in the NEUTRAL position.
4. Connect battery and spark plug wire(s). **See Connecting The Battery on page 1-3.**

## REVERSE WARNING BUZZER

See **General Warning, Section 1, Page 1-1.**

### Testing the Reverse Warning Buzzer

See **Test Procedure 20, Section 11, Page 11-31.**

### Reverse Warning Buzzer Removal

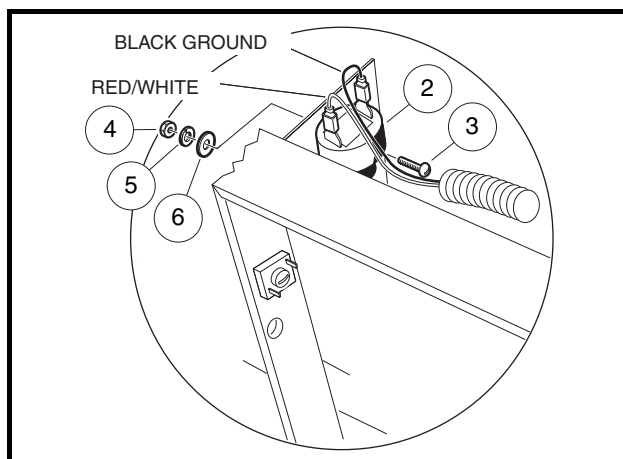
1. Turn the key switch OFF and remove the key. Place the Forward/Reverse handle in the NEUTRAL position. Chock the wheels.
2. Disconnect battery and spark plug wire(s). **See Disconnecting The Battery on page 1-3.**
3. Remove the dash panel for front mounted buzzer removal. **See Key Switch Removal on page 12-24.**
4. Raise the bed on the Carryall 472/XRT 1200 SE for rear mounted buzzer removal.
5. Disconnect the wires from the reverse warning buzzer (2) (**Figure 12-36, Page 12-29**).
6. Remove the screw (3), nut (4), lockwasher (5) and flat washer (6) securing the front buzzer to the vertical frame support.
7. Remove the screws, nuts, lockwashers and flat washers securing the rear buzzer to the cross frame support between the bed hinges under the rear of the bed.

### Reverse Warning Buzzer Installation

1. Install the screw (3) through the buzzer (2) bracket tab and frame for front and/or rear warning buzzer, secure with hardware, and tighten to 14 in-lb (1.6 N·m) (**Figure 12-36, Page 12-29**). **See following NOTE.**

**NOTE:** The reverse warning buzzer is secured at one hole only in the front and both holes in the rear.

2. Connect the black wire from the wire harness to the negative (–) terminal on the buzzer.
3. Connect the red/white wire from the wire harness to the positive (+) terminal on the buzzer.
4. Install the dash in reverse order of removal. **See Key Switch Removal on page 12-24.**
5. Connect battery and spark plug wire(s). **See Connecting The Battery on page 1-3.**



**Figure 12-36 Front Reverse Warning Buzzer**

## REVERSE BUZZER LIMIT SWITCH

---

See General Warning, Section 1, Page 1-1.

### Testing the Reverse Buzzer Limit Switch

See Test Procedure 19, Section 11, Page 11-31.

### Reverse Buzzer Limit Switch Removal

1. Turn the key switch OFF and remove the key. Place the Forward/Reverse handle in the NEUTRAL position. Chock the wheels.
2. Disconnect battery and spark plug wire(s). **See Disconnecting The Battery on page 1-3.**
3. Disconnect the wires from the reverse buzzer limit switch (4) located on the back of the Forward/Reverse assembly (**Figure 12-34, Page 12-28**).
4. Remove the nuts (2) and washers (6) from the lockout cam limit switch (5) and slide the lockout cam limit switch off of the screws. Do not disconnect the wires.
5. Remove the spacers (9) from the reverse buzzer limit switch (4) and slide the reverse buzzer limit switch off the screws.

### Reverse Buzzer Limit Switch Installation

1. Install the reverse buzzer limit switch (4), and then install two spacers (9) against the limit switch.
2. Install the lockout cam limit switch (5) with two washers (6) and two nuts (2) and tighten to 5 in-lb (0.6 N·m). **See following CAUTION.**

### **⚠ CAUTION**

- **Do not overtighten the retaining nuts. If the nuts are overtightened, limit switches could be damaged.**
3. Place the Forward/Reverse handle in REVERSE to make sure that only the reverse buzzer limit switch is actuated.
  4. Connect the orange wire to the black wire (COM) terminal and the red/white wire to the blue wire, normally open (NO) terminal of the reverse buzzer limit switch (4) (**Figure 12-34, Page 12-28**).
  5. Connect battery and spark plug wire(s). **See Connecting The Battery on page 1-3.**
  6. Turn the key switch to the ON position. With the Forward/Reverse handle in REVERSE, the buzzer should sound.

## OIL WARNING LIGHT

---

See General Warning, Section 1, Page 1-1.

### Testing the Oil Warning Light

See Test Procedure 22, Section 11, Page 11-32.

### Oil Warning Light Removal

1. Turn the key switch OFF and remove the key. Place the Forward/Reverse handle is in the NEUTRAL position. Chock the wheels.
2. Disconnect battery and spark plug wire(s). **See Disconnecting The Battery on page 1-3.**



3. Remove the dash panel. **See Key Switch Removal on page 12-24.**
4. Disconnect the wires from the oil warning light (1) (**Figure 12-37, Page 12-31**). Do not allow wires to touch.
5. Press the retaining tabs and remove the light from the center dash.

### Oil Warning Light Installation

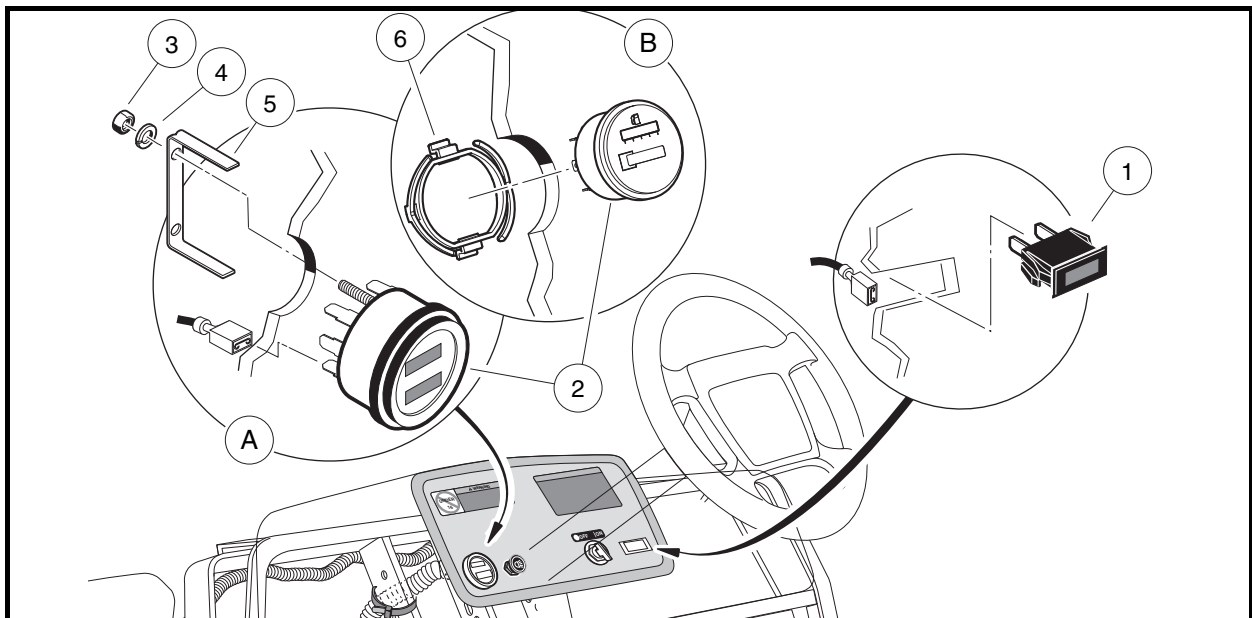
1. Push a new unit into hole in dash until plastic tabs engage dash (**Figure 12-37, Page 12-31**).
2. Connect the two yellow wires from the wire harness to the oil warning light.
3. Install the dash in reverse order of removal. **See Key Switch Removal on page 12-24.**
4. Connect battery and spark plug wire(s). **See Connecting The Battery on page 1-3.**

## FUEL GAUGE/HOUR METER

See General Warning, Section 1, Page 1-1.

### Testing the Fuel Gauge/Hour Meter

See Test Procedure 26, Section 11, Page 11-34. Also see Test Procedure 27 – Hour Meter on page 11-37.



**Figure 12-37 Fuel Gauge/Hour Meter and Oil Warning Light Assembly**

A. Used 2006 through mid-2007 Model Year B. Started mid-2007 Model Year

**2006 to mid-2007 vehicles:** With the key switch in the OFF position, the fuel gauge/hour meter fields are blank. When the key switch is turned to ON, both fields activate. **Mid-2007 and newer vehicles:** With the key switch in the OFF position, the fuel gauge field is blank; however, the hour meter field is always ON. When the key switch is turned to ON, the fuel gauge field activates. **All model years:** The fuel gauge initially registers full before indicating the actual fuel level.

The hour meter displays the number of hours of use in increments of 0.1 (one tenth) hour, but does not record additional time unless the key switch is in the ON position and the engine is on. When recording, the hour-glass icon on the left blinks (slowly on Early 2007 vehicles).

### Fuel Gauge/Hour Meter Removal

1. Turn the key switch OFF and remove the key. Place the Forward/Reverse handle in the NEUTRAL position. Chock the wheels.
2. Disconnect battery and spark plug wire(s). **See Disconnecting The Battery on page 1-3.**
3. Remove the dash panel. **See Key Switch Removal on page 12-24.**
4. Disconnect the wires from the fuel gauge/hour meter (2) (**Figure 12-37, Page 12-31**). Do not allow wires to touch.
5. Remove the fuel gauge/hour meter.
  - 5.1. **2006 to mid-2007 vehicles:** Remove the two hex nuts (3) and lockwashers (4) from the threaded studs on the back of the gauge. Remove the mounting bracket (5) from the back side of the gauge/meter and remove it from the instrument panel.
  - 5.2. **Mid-2007 and newer vehicles:** Remove the mounting clip (14) that secures the gauge/meter. Alternate pulling the lower and upper tabs away from the gauge housing to remove clip. Pull gauge/meter from the instrument panel.

### Fuel Gauge/Hour Meter Installation

1. Install a new gauge/meter into hole in dash until flange seats against dash (**Figure 12-37, Page 12-31**).
2. Secure the fuel gauge/hour meter.
  - 2.1. **2006 to mid-2007 vehicles:** Slide the mounting bracket onto the two threaded studs on the fuel gauge/hour meter. Secure the fuel gauge/hour meter with two lockwashers and two hex nuts. Tighten to 2.5 in-lb (.28 N·m). Place one drop of Loctite on each hex nut. Do not allow Loctite to come into contact with the fuel gauge/hour meter casing.
  - 2.2. **Mid-2007 and newer vehicles:** Force the mounting clip (14) onto the back of the fuel gauge/hour meter until fully seated.
3. Connect the wires to the fuel gauge/hour meter. **See Wiring Diagrams, Section 11, Page 11-6.**
4. Coat the terminals with Battery Terminal Protector Spray (CC P/N 1014305).
5. Install the dash in reverse order of removal. **See Key Switch Installation on page 12-24.**
6. Connect battery and spark plug wire(s). **See Connecting The Battery on page 1-3.**

## FUEL LEVEL SENDING UNIT

---

### See General Warning, Section 1, Page 1-1.

The fuel level sending unit is an integral part of the fuel tank and should never be removed. Thoroughly test the fuel level sending unit before replacing the fuel tank.

### Testing the Fuel Level Sending Unit

**See Test Procedure 25, Section 11, Page 11-33.**

## RPM LIMITER

See General Warning, Section 1, Page 1-1.

### Testing the RPM Limiter

See Test Procedure 15, Section 11, Page 11-24.

### RPM Limiter Removal

1. Turn the key switch OFF and remove the key. Place the Forward/Reverse handle in the NEUTRAL position. Chock the wheels.
2. Disconnect battery and spark plug wire(s). **See Disconnecting The Battery on page 1-3.**
3. Disconnect the white/black wire from the black wire at the bullet connector located near the RPM limiter (**Figure 12-38, Page 12-33**).
4. Disconnect the other black wire at the other bullet connector near the RPM limiter.
5. Remove the flange head bolts from the RPM limiter band and remove the RPM limiter and damper (**Figure 12-38, Page 12-33**).

### RPM Limiter Installation

1. Place the RPM limiter on the damper squarely so that RPM limiter fits tightly against the damper.
2. Place the RPM limiter with damper on the front of the RPM limiter mounting bracket (**Figure 12-38, Page 12-33**).
3. Place the band over the RPM limiter and align the holes. Place the brown wire ring connector onto the flange head bolt and secure the left side of the band. Use another flange head bolt to secure the other side of the band. Make sure the band holds the RPM limiter securely in place. Tighten fasteners to 7 ft-lb (9.5 N·m).
4. Connect the black wire at the two wire female bullet connector to the white/black kill circuit wire.
5. Connect other female bullet of the black coil wire to the ignition coil bullet terminal.
6. Connect battery and spark plug wire(s). **See Connecting The Battery on page 1-3.**

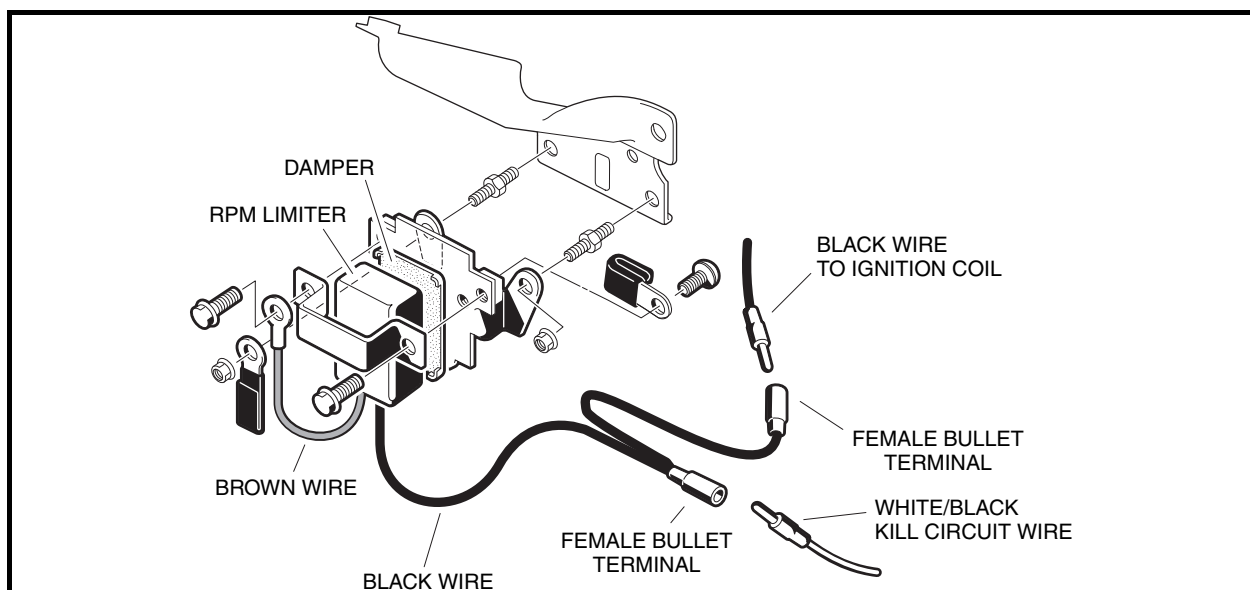


Figure 12-38 RPM Limiter Assembly

## IGNITION COIL

---

**See General Warning, Section 1, Page 1-1.**

The ignition coil is located under the flywheel shroud of the engine. To replace it requires the removal and installation of the engine and transaxle. It is recommended that the ignition coil be thoroughly tested prior to replacement.

### Testing the Ignition Coil

**See Test Procedure 14, Section 11, Page 11-23. Also see Test Procedure 15 – RPM Limiter on page 11-24 and Test Procedure 16 – Ignition Coil on page 11-24.**

### Ignition Coil Removal

Removing the ignition coil requires the removal of the engine and unitized transaxle. **See Unitized Transaxle Removal, Section 16, Page 16-6. See following CAUTION.**

#### **CAUTION**

- **Before removal and disassembly, clean the engine.**

1. Remove the starter/generator. **See Starter/Generator Removal on page 12-1. See following NOTE.**

**NOTE:** *The crankshaft has left-hand threads at the clutch mounting hole.*

2. Remove the muffler. **See Muffler Removal, Section 15, Page 15-1.**
3. Remove the engine mounting hardware (items 1, 2, and 5). **See Figure 13-1, Section 13, Page 13-4.**
4. Remove the two nuts (6) and washers (3) from the stud bolts on the engine body.
5. Slide the engine away from the transaxle housing and lift the engine from the mounting plate.
6. Place the engine on a solid, flat surface, preferably on a sturdy work bench.
7. Remove the pan head bolts (5) securing the fan shroud (8) to the fan housing (9) (**Figure 12-39, Page 12-35**).
8. Loosen, but do not remove, three bolts (6) attaching the fan housing as shown.
9. Remove the remaining four bolts (10) attaching the fan housing (**Figure 12-39, Page 12-35**), then while opening the housing, detach the spark plug wire grommet (4) from the housing (**Figure 12-41, Page 12-36**).
10. Disconnect the 18-gauge black wire (12) from the spade terminal (13) on the ignition coil (11) and remove the coil by removing two bolts (10) (**Figure 12-40, Page 12-35**).

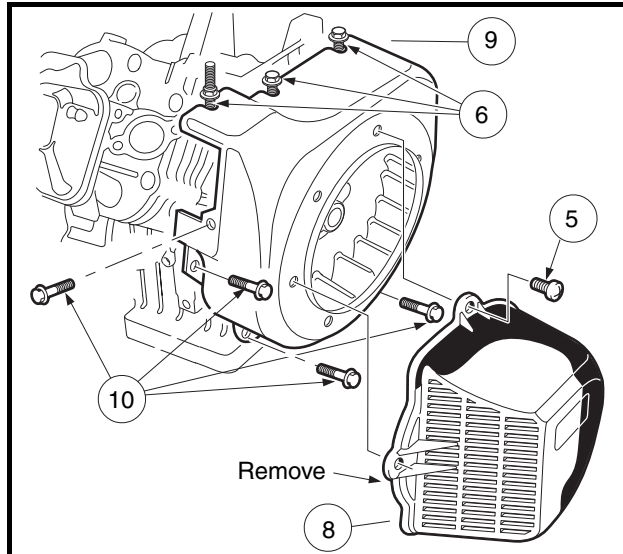


Figure 12-39 Remove Fan Housing

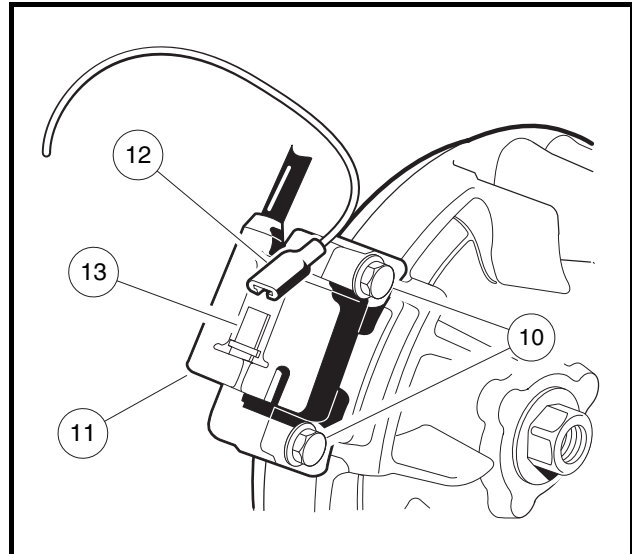


Figure 12-40 Black Wire and Ignition Coil

## Ignition Coil Installation

**NOTE:** If a new ignition coil is being installed, the spark plug cap, gasket, protector tube and grommet must be removed from the old coil and installed on the new coil. See steps 1 through 8 for procedures to remove and install these existing parts.

If the existing ignition coil will be remounted, proceed to step 9.

1. Remove the rubber gasket (1) on the plug cap (2) by rolling back the gasket onto the spark plug wire.
2. Remove the cap (2) from the wire by turning the cap counterclockwise three or four revolutions while gently pulling it off the wire (Figure 12-41, Page 12-36).
3. Remove the gasket (1) and protector tube (3) from the old coil. See following NOTE.

**NOTE:** Moisten the spark plug wire with water to make gasket removal and installation easier.

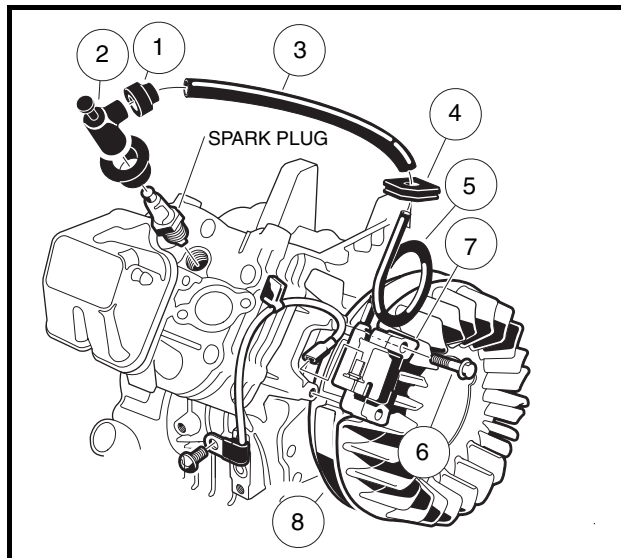
4. Remove the grommet (4) from the old spark plug wire. Clean the grommet and place it on the new spark plug wire (5).
5. Install the protector tube (3) onto the new wire (Figure 12-41, Page 12-36).
6. Slide the gasket (1) onto the end of the new spark plug wire.
7. Install the cap (2) on the new coil spark plug wire by rotating it clockwise three or four revolutions while applying light pressure on the cap.
8. Install the gasket (1) on the cap (2).
9. Position the ignition coil (7) onto the cast mounting bosses on the engine crankcase and tighten the two mounting bolts (6) finger-tight.
10. Rotate the flywheel (8) until the magnet is positioned directly under the ignition coil. Use a 0.012 inch (0.304 mm) bronze feeler gauge to set the air gap between the ignition coil and the flywheel magnet. Tighten the two mounting bolts (6) to 30 in-lb (3.4 N·m) (Figure 12-42, Page 12-36).
11. Connect 18-gauge black (12) wire to the spade terminal (13) on the coil (Figure 12-40, Page 12-35).
12. Position the fan housing close to the engine crankcase and slide the plug wire grommet into the notch on the housing.

13. When installing fan housing, make sure the top front corner of the housing is above the upper cylinder shroud. The front edge of the fan housing should be behind the lower cylinder shroud. Align the slots in the housing with the flanged bolts (6) loosened earlier (**Figure 12-39, Page 12-35**).
14. Install the four remaining flanged bolts (10) that secure the fan housing to the engine crankcase. Tighten all seven mounting bolts (6) and (10) to 90 in-lb (10.2 N·m).
15. Install the fan shroud with four pan-head bolts (5) and tighten to 50 in-lb (5.7 N·m).
16. Place the engine onto the engine mounting plate and slide the two washers (3) onto the two engine body bolts, then slide the bolts through the mounting plate and transaxle housing. Loosely attach the two nuts (6) finger-tight. **See Figure 13-1, Section 13, Page 13-4.**
17. Attach the engine to the bottom of the engine mounting plate using the bolts (1), washers (2) and nuts (5). Tighten hardware to 21 ft-lb (28.4 N·m). **See Figure 13-1, Section 13, Page 13-4.**
18. Tighten the two engine body bolt nuts (6) to 17 ft-lb (23.1 N·m).
19. Install the engine and transaxle assembly. **See Unitized Transaxle Installation, Section 16, Page 16-15. See following CAUTION.**

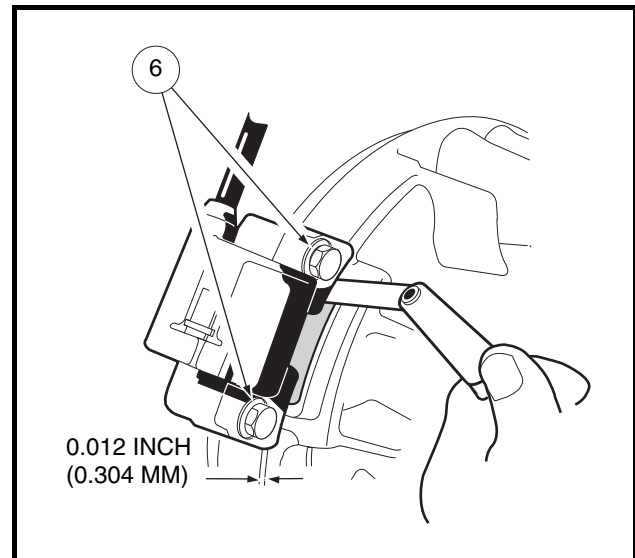
### **CAUTION**

- **Make sure wire harness is routed and secured away from the muffler.**

20. Install the muffler. **See Muffler Installation, Section 15, Page 15-1.**



**Figure 12-41 Clean Grommet**



**Figure 12-42 Mount Ignition Coil Using Feeler Gauge**

21. Install the starter/generator and belt. **See Starter/Generator Installation on page 12-9.**
22. Connect battery and spark plug wire(s). **See Connecting The Battery on page 1-3.**

## OIL LEVEL SENSOR

See General Warning, Section 1, Page 1-1.

### Testing the Oil Level Sensor

See Test Procedure 21, Section 11, Page 11-32.

### Oil Level Sensor Removal

See Oil Level Sensor Installation, Section 13, Page 13-5.

### Oil Level Sensor Installation

See Oil Level Sensor Installation, Section 13, Page 13-5.

## HEADLIGHTS

See General Warning, Section 1, Page 1-1.

### Testing the Headlight Socket

See Test Procedure 30, Section 11, Page 11-40.

### Headlight Bulb Removal

1. Turn the key switch OFF and remove the key. Place the Forward/Reverse handle in the NEUTRAL position. Chock the wheels.
2. Disconnect battery and spark plug wire(s). **See Disconnecting The Battery on page 1-3.**
3. From the front of vehicle, reach under cowl and turn the wire harness/halogen bulb assembly (4 and 6) clockwise one-quarter turn (**Figure 12-43, Page 12-37**).
4. Remove the wire harness/halogen bulb assembly (4 and 6) from the headlight lens (7).
5. Lift the retaining tabs on the connector (4) and remove halogen bulb assembly (6).

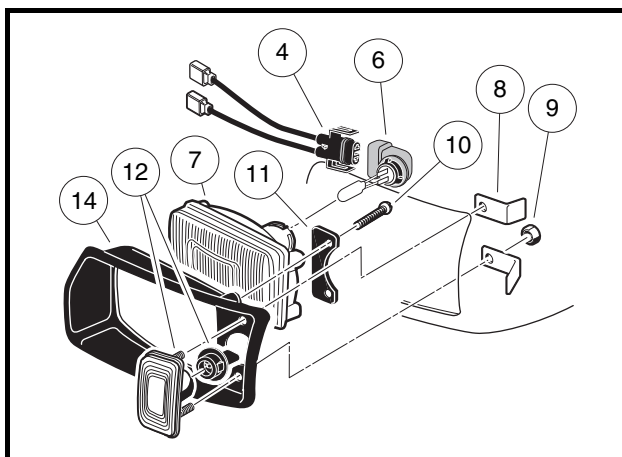


Figure 12-43 Headlight Assembly

### Headlight Bulb Installation

**NOTE:** When handling halogen bulbs, do not touch glass portion of bulb. Oil from finger tips can cause premature failure of bulb.

1. Connect wire harness (4) to the halogen bulb assembly (6). The retaining tab should lock onto the halogen bulb assembly (**Figure 12-43, Page 12-37**).
2. From the front of vehicle, reach under cowl and insert wire harness/halogen bulb assembly (4 and 6) into the headlight lens (7).
3. Turn the wire harness/halogen bulb assembly (4 and 6) counterclockwise one-quarter turn.
4. Connect battery and spark plug wire(s). **See Connecting The Battery on page 1-3.**

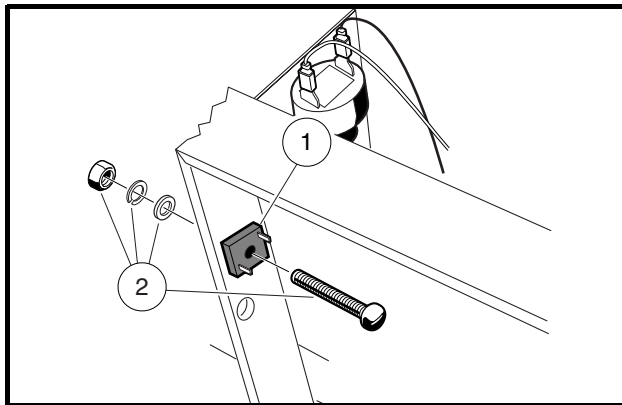


Figure 12-44 Headlight Diode

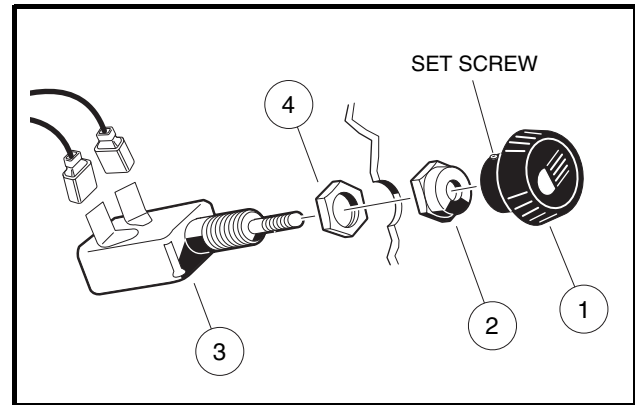


Figure 12-45 Light Switch

## HEADLIGHT DIODE

See **General Warning, Section 1, Page 1-1.**

### Testing the Headlight Diode

See **Test Procedure 29, Section 11, Page 11-39.**

### Headlight Diode Removal

1. Turn the key switch OFF and remove the key. Place the Forward/Reverse handle in the NEUTRAL position. Chock the wheels.
2. Disconnect battery and spark plug wire(s). **See Disconnecting The Battery on page 1-3.**
3. Remove the center dash panel. **See Key Switch Removal on page 12-24.**
4. Disconnect wires from the headlight diode (1). Do not allow wires to touch (**Figure 12-44, Page 12-38**).

**NOTE:** Identify terminal for solid black wire and terminal for black/white wire.

5. Remove the mounting hardware (2) from the headlight diode and remove it from the vehicle.

### Headlight Diode Installation

1. Mount the headlight diode to the frame using the mounting hardware and tighten to 25 in-lb (2.8 N·m) (**Figure 12-44, Page 12-38**).
2. Connect the black/white wire from harness to the negative (–) terminal on the diode.
3. Connect the solid black wire from the ground terminal block to the positive (+) terminal on the diode.
4. Install the dash panel in reverse order of removal. **See Key Switch Removal on page 12-24.**
5. Connect battery and spark plug wire(s). **See Connecting The Battery on page 1-3.**



## LIGHT SWITCH

---

See General Warning, Section 1, Page 1-1.

### Testing the Light Switch

See Test Procedure 28, Section 11, Page 11-38.

### Light Switch Removal

1. Turn the key switch OFF and remove the key. Place the Forward/Reverse handle in the NEUTRAL position. Chock the wheels.
2. Disconnect battery and spark plug wire(s). **See Disconnecting The Battery on page 1-3.**
3. Loosen the set screw locking the light switch knob (1) to the shaft (**Figure 12-45, Page 12-38**).
4. Remove the dash panel. **See Key Switch Removal on page 12-24.**
5. Disconnect the wires from the light switch.
6. Remove the outer nut (2) from the light switch (3) and remove.

### Light Switch installation

1. Connect the wires to the light switch. **See Wiring Diagrams, Section 11, Page 11-6.**
2. Thread the check nut (4) onto the switch until an equal number of threads show on both sides. Install to the dash panel with nut (2) on the outside of the dash and tighten the nut to 14 in-lb (1.6 N·m) (**Figure 12-45, Page 12-38**).
3. Push the light switch shaft in. Screw the knob onto the end of the shaft until the knob touches the outer nut. Then turn the knob in the opposite direction until the headlight beams on the knob are horizontal to the ground. Tighten the set screw to lock the knob to the shaft.
4. Install the dash panel in reverse order of removal. **See Key Switch Removal on page 12-24.**
5. Connect battery and spark plug wire(s). **See Connecting The Battery on page 1-3.**

## BATTERY

---

See General Warning, Section 1, Page 1-1.

### **⚠ DANGER**

- Due to the danger of an exploding battery, wear a full face shield and rubber gloves when working around a battery.
- **Battery – Explosive gases! Do not smoke. Keep sparks and flames away from the vehicle and service area. Ventilate when charging or using in an enclosed space. Wear a full face shield and rubber gloves when working on or near batteries. For added protection, cover top of the battery when servicing the vehicle.**
- **Battery – Poison! Contains acid! Causes severe burns! Avoid contact with skin, eyes, or clothing.**
  - **External: Flush with water. Call a physician immediately.**

- **Internal: Drink large quantities of milk or water. Follow with milk of magnesia or vegetable oil. Call a physician immediately.**
- **Eyes: Flush with water for 15 minutes. Call a physician immediately.**

## General Information

### See preceding DANGER statement.

Club Car gasoline vehicles are equipped with 12-volt, low-maintenance batteries. When changing a 12-volt battery in any Club Car gasoline-powered vehicle, the same size battery with adequate amperage ratings should be used as a replacement.

Club Car recommends a group 70, side-post battery (CC P/N 1012328), with a 650 cranking amp rating at 32 °F (0 °C) (500 CCA at 0 °F (-17.8 °C)) and a reserve capacity of at least 105 minutes. The group 70 classification indicates battery size: 8-1/4 inches W x 6-1/2 inches D x 7-1/4 inches H (21.0 cm W x 16.5 cm D x 18.4 cm H). It is important to use the proper size to ensure that the battery clamp will fit correctly.

## Testing the Battery

See Test Procedure 1, Section 11, Page 11-11. Also see Test Procedure 24 – Battery Test (Under Load) on page 11-33.

## Preventive Maintenance

1. To keep the battery in good operating condition, remove any corrosion immediately. Post connections should be clean and tight. Any frayed or worn wires should be replaced. After all cables have been connected and properly tightened to 80 in-lb (9 N·m), coat terminals with Battery Terminal Protector Spray (CC P/N 1014305) to prevent future corrosion.
2. The battery should be kept clean and dry to prevent self-discharge. Any dirt, grime or acid spillage should be removed. Wash the battery with a bristle brush using water and bicarbonate of soda (1 cup (237 mL) baking soda per 1 gallon (3.8 L) of water). Rinse with water. Do not allow solution to enter battery through the vent cap holes. **See Self-Discharge on page 12-40.**
3. Maintain proper water level. **See Water Level on page 12-40.**
4. Check battery periodically to see that it is in a full state of charge. **See Charging the Battery on page 12-42.**
5. Keep battery hold-down clamp tight. **See Vibration Damage on page 12-40.**

## Self-Discharge

Dirt and battery acid can provide a path for a small current draw that slowly discharges the battery. To prevent self-discharge, the battery should always be kept clean.

Hot weather also has an effect on a battery's self-discharge rate. The higher the temperature, the quicker a battery will discharge. In hotter climates, therefore, the battery should be checked more often. When storing the battery, keep in a cool place. **See Battery Storage on page 12-43.**

## Water Level

The water level should be checked semi-annually to be sure water is at its proper level. Never allow the water level to fall below the tops of the plates because this will cause the exposed part of the plate to become permanently inactive. Check the water level more frequently in hot weather or when the battery becomes old. **See Figure 11-7, Section 11, Page 11-12.**

## Vibration Damage

The battery hold-down clamp should always be tight enough to keep the battery from bouncing. Battery life may be severely shortened if the clamp is too loose. Excessive vibration shortens the life of the battery. It may

also cause acid to leak out of the vent caps and corrosion to build up on surrounding metal parts. The acid that is lost reduces the capacity of the battery and cannot be replaced.

## Mineral Content

For the longest battery life, distilled water should be used in the battery. However, if tap water is going to be used, contact your local water department to be sure mineral contents are below the levels listed in the following table. **See following NOTE.**

**NOTE:** Contact your local water department for mineral content analysis.

IMPURITY	ALLOWABLE CONTENT (PARTS PER MILLION)	EFFECTS OF IMPURITY
Suspended matter	Trace	–
Total solids	100.0	–
Calcium	40.0	Increase of positive shedding
Magnesium	40.0	Reduced life
Iron	3.0	Increased self-discharge at both plates, lower on-charge voltage
Ammonia	8.0	Slight self-discharge of both plates
Organic and volatile matter	50.0	Corrosion of positive plate
Nitrates	10.0	Increased sulfation at negative
Nitrites	5.0	Corrosion at both plates, loss of capacity, reduced life
Chloride	5.0	Loss of capacity in both plates, greater loss in positive
Color	Clear and “White”	–
Antimony	5.0	Self-discharge by local action, reduces life, lower on-charge voltage
Arsenic	0.5	Self-discharge, can form poisonous gas at negative
Copper	5.0	Increased self-discharge, lower oncharge voltage
Nickel	None Allowed	Intense lowering of on-charge voltage
Platinum	None Allowed	Violent self-discharge, lower on-charge voltage
Selenium	2.0	Positive shedding
Zinc	4.0	Slight self-discharge at negative

## Battery Removal

**See General Warning, Section 1, Page 1-1 and DANGER on page 12-39.**

1. Turn the key switch OFF and remove the key. Place the Forward/Reverse handle in the NEUTRAL position. Chock the wheels.
2. Disconnect battery and spark plug wire(s). **See Disconnecting The Battery on page 1-3.**
3. **Turf 272/Carryall 272/XRT 1200:**
  - 3.1. Remove the four bolts (8), eight washers (9) and four locknuts (10) from the armrests. **See Figure 4-3, Section 4, Page 4-8.**
  - 3.2. Remove the two armrests (11 and 12) from the vehicle.
  - 3.3. Carefully lift and rotate the seat support 90° counterclockwise and allow it to rest on the vehicle

body as illustrated (Figure 12-46, Page 12-42). See following NOTE.

**NOTE:** It is not necessary to remove the park brake cable or differential lock cable to service or remove the battery.

#### 4. Carryall 472/XRT 1200 SE:

- 4.1. Remove the rear seat.
  - 4.2. Remove the choke cable and bracket from the air filter box.
5. Remove the battery hold-down clamp from the battery and remove. See following WARNING.

### **⚠ WARNING**

- Keep the battery in an upright position to prevent electrolyte leakage. Tipping the battery beyond a 45° angle in any direction can allow a small amount of electrolyte to leak out of the vent hole. Do not exceed this 45° angle when lifting, carrying or installing battery. The battery acid could cause severe personal injury when accidentally coming in contact with the skin or eyes, and could damage clothing.

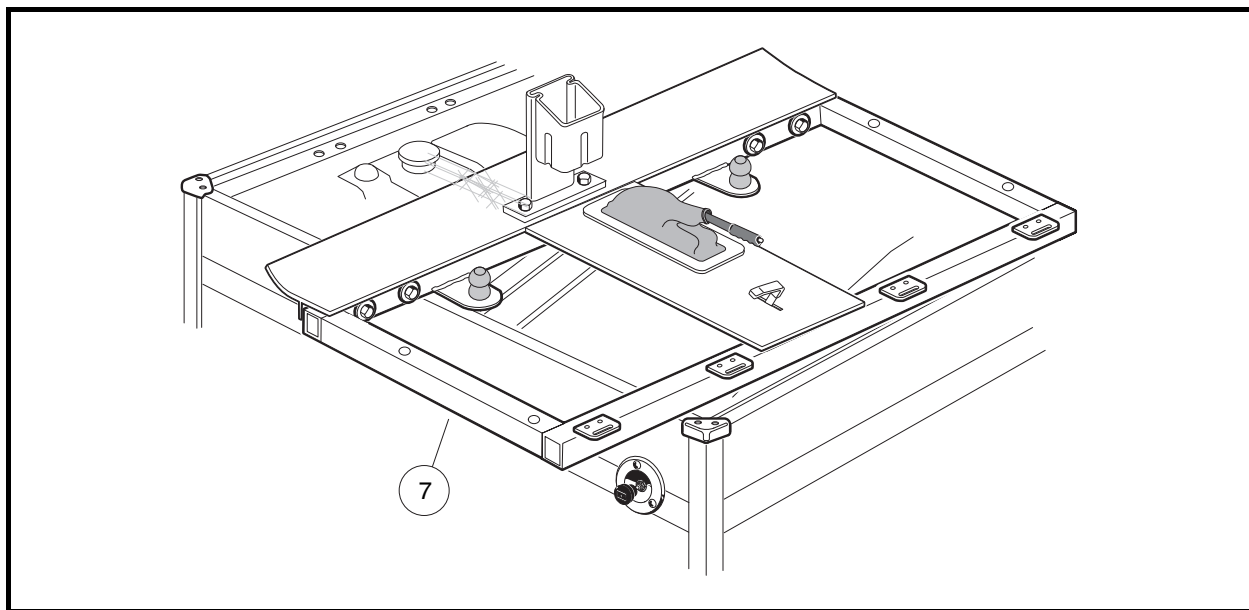


Figure 12-46 Turf 272/Carryall 272/XRT 1200 Battery Removal

## Charging the Battery

See General Warning, Section 1, Page 1-1 and DANGER on page 12-39.

1. Charge the battery using an automotive type 12-volt battery charger. Follow all warnings and procedures supplied by the battery charger manufacturer.
2. Attach the charger, positive (+) cable to the positive (+), and negative (-) cable to the negative (-) battery post.
3. The battery may be charged with a slow charge (3-10 amps) or a fast charge (20-30 amps). Charge until the specific gravity reaches 1.250. See following WARNING.

### **⚠ WARNING**

- If the battery case feels hot (approximately 125 °F (52 °C) or more), emits gases, or fluid boils from vents, stop charging immediately. Failure to stop charging battery when any of these conditions are present could result in an explosion, personal injury and/or damage to the battery.
- Do not disconnect the charger DC leads from the battery when the charger is on. The resulting arcing between the DC leads and battery post could cause an explosion.
- If the charger must be stopped, disconnect the AC supply cord from the wall outlet before disconnecting the DC leads from the battery. Allow the battery to cool to room temperature and resume charging battery at a lower amp rate.

## Battery Installation

See General Warning, Section 1, Page 1-1 and DANGER on page 12-39.

1. Place the battery into the vehicle with the battery posts facing the engine.
2. Secure the battery to the vehicle with the clamp and install bolt, washer and locknut and tighten to 144 in-lb (16.3 N·m).
3. Connect battery and spark plug wire(s). See Connecting The Battery on page 1-3.
4. **Turf 272/Carryall 272/XRT 1200:**
  - 4.1. Return the seat support to its original position by rotating it 90° clockwise. Install the armrests using four bolts, eight washers and four locknuts. Tighten bolts (8) to 13 ft-lb (17.6 N·m). See Figure 4-3, Section 4, Page 4-8.
  - 4.2. Check the park brake and differential lock lever for proper adjustment and operation.
5. **Carryall 472/XRT 1200 SE:**
  - 5.1. Install the choke cable end into the choke lever and attach the support bracket with an #8 x 1/2-inch screw and tighten to 15 in-lb (1.7 N·m).
  - 5.2. Install the rear seat.

## Battery Storage

See General Warning, Section 1, Page 1-1 and DANGER on page 12-39.

1. Keep the battery clean and free of corrosion. See Preventive Maintenance on page 12-40.
2. The battery cables should be disconnected from the vehicle so it can be connected to the charger. The battery can be left in the vehicle. Disconnect battery and spark plug wire(s). See Disconnecting The Battery on page 1-3.
3. Fully charge the battery prior to storage.
4. Store in a cool, dry area. The colder the area in which the battery is stored, the less the battery will self-discharge. A battery stored at 0 °F (-17.8 °C) will discharge very little over a four-month period. A battery stored at 80 °F (27 °C) will have to be recharged every few weeks.
5. Check the state of charge periodically. A battery that is discharged and left in a cold environment can freeze and crack. If the specific gravity drops below 1.220, the battery should be recharged. See following WARNING.

### **⚠ WARNING**

- If the battery is frozen or the container is bulged, discard battery. A frozen battery can explode.

6. The frequency of recharging required depends on the temperature of the storage area, but it is recommended that the battery be monitored for state of charge every month. Also, if the storage area is unheated in a cold climate and recharging is required, it is recommended that the area be heated to at least 60 °F (16 °C) prior to charging. The battery will not charge effectively in cold temperatures for the same reasons that it does not discharge as rapidly in cold temperatures.

### Charging a Dead Battery

**See General Warning, Section 1, Page 1-1 and DANGER on page 12-39.**

The vehicle is equipped with a starter/generator. The generator is not designed to charge a dead battery. If the vehicle battery has become discharged, it must be charged using a properly rated automotive type charger. **See following WARNING.**

#### **WARNING**

- Do not jump-start a dead battery using another battery and jumper cables.

## GROUND CABLES

---

### Testing the Ground Cables

**See Test Procedure 3, Section 11, Page 11-14.**

# SECTION 13 – FE400 ENGINE

---

## **⚠ DANGER**

- See General Warning, Section 1, Page 1-1.

## **⚠ WARNING**

- See General Warning, Section 1, Page 1-1.

## GENERAL INFORMATION

---

### See General Warning, Section 1, Page 1-1.

The Turf 272, Carryall 272, Carryall 472, XRT 1200 and XRT 1200 SE model vehicles are powered by an FE400 engine and key-start with neutral "rev".

**NOTE:** Engine rotation on the engine is clockwise as viewed from the clutch side of the engine.

This Section contains information on removing and replacing the FE400 engine. For complete instructions on engine disassembly, repair, rebuilding, and reassembly, see the Engines and Transaxles Manual (CC P/N 102396501).

## BEFORE SERVICING

Carefully read the applicable information and instructions before beginning engine service. Diagrams, DANGER, WARNING, CAUTION and NOTE statements and detailed descriptions have been included wherever necessary. Anyone attempting engine service should have knowledge and experience in small engine service and repair.

1. Turn the key switch OFF and remove the key. Place the Forward/Reverse handle in the NEUTRAL position. Chock the wheels.
2. Disconnect battery and spark plug wire(s). **See Disconnecting The Battery on page 1-3.**

## Molybdenum Disulfide (MoS<sub>2</sub>) Grease

**NOTE:** This manual makes reference to molybdenum disulfide grease in the assembly of certain engine and chassis parts. Always refer to manufacturer's recommendations printed on the container before using such special lubricants.

## Engine Rotation

When turning the crankshaft by hand, always turn it clockwise as viewed from the clutch side of the engine. This will ensure proper adjustments.

## LUBRICATION SYSTEM

FE400 engines are equipped with hydraulic lifters and a pressurized lubrication system.

## SPARK PLUG

Spark plugs are selected to suit specific engine design and vehicle operating conditions. The spark plug (CC P/N AM1232301) is designed for FE400 engines, providing maximum life and efficient combustion of fuel. The spark gap should be set to 0.027 - 0.031 inches (0.69 - 0.79 mm).

### Spark Plug Removal

See General Warning, Section 1, Page 1-1.

#### **CAUTION**

- Before removal and disassembly, clean the engine.

Remove all dirt from plug base in the cylinder head before removing plug. Use a 13/16 deep well socket wrench or 13/16-inch plug wrench to loosen the plug.

### Spark Plug Cleaning, Inspection and Repair

Examine the plug. The deposits on the plug base and electrode are an indication of the correct heat range and efficiency as well as a guide to the general condition of the engine, fuel and air mixture and ignition system. If all of the above conditions are proper, the spark plug should be a light brown color. There should be no bridging between the electrode and base. The electrode should not be eroded. Black color, excessive carbon and/or a wet plug indicate a too rich condition. White, burned or melted electrodes indicate a too lean condition or pre-ignition. Oily deposits on the plug electrode are an indication of worn rings, valve guides, cylinder wall, etc. Also examine the spark plug wire. Remove rubber boot and inspect internal spring for damage. Inspect spark plug wire for damage and be sure spring coil is securely attached to spark plug. **See following WARNING.**

#### **⚠ WARNING**

- Remove spark plug wire to avoid accidental start up of the engine when servicing vehicle. To avoid ignition of fuel and serious personal injury or death, never try to start the engine with plug removed from engine.

### Testing the Spark Plug

Check the sparking ability of a cleaned and regapped plug on a sparking comparator if possible. Spark should be blue and strong and able to jump a 5/16-inch (8 mm) gap.

### Setting the Spark Gap

1. Pass a contact point file between the electrodes to produce flat, parallel surfaces to facilitate accurate gauging.
2. Use a wire type gauge. Bend the outside or ground electrode so only a slight drag on the gauge is felt when passing it between the electrode. Never make an adjustment by bending the center electrode. Set gap (A) to 0.027 - 0.031 inches (0.69 - 0.79 mm).

### Spark Plug Installation

**NOTE:** Before installing the plug, check the condition of the threads in the cylinder head. Soften deposits in cylinder head threads with penetrating oil and clean the threads with a tap if necessary.

Use a high temperature, anti-seize lubricant on the threads of the spark plug to reduce friction when installing a new plug and reduce gauling and thread seizing for future replacements.

1. Install the spark plug and thread it in until finger-tight, then tighten the spark plug to 20 ft-lb (27 N·m).



---

## CYLINDER

---

**See General Warning, Section 1, Page 1-1.**

Test cylinder compression using a standard compression tester. Low compression would normally indicate a problem in the cylinder assembly such as defective rings, gaskets, etc.

FE400 model engines are equipped with an automatic compression release valve (ACR). This valve releases compression pressure at normal cranking RPM, resulting in lower compression. At a normal cranking speed of 550 - 600 RPM, the compression should be typically 71 psi. This value could vary slightly depending on wear of components affecting compression.

### BREATHER VALVE (REED VALVE)

The function of the breather is to create a vacuum in the crankcase which prevents oil from being forced out of the engine through the piston rings, oil seals or gaskets. The breather has a reed valve which limits the direction of air flow caused by the piston moving up and down. Air can flow out of the crankcase, but the one-way reed valve blocks return flow. It thus maintains a vacuum in the crankcase.

Oil laden air in the crankcase passes through the reed valve and expands into the rocker chamber. In the rocker chamber most oil separates from the air and drains back to the crankcase. The air passes through a tube and vents to the intake manifold.

### VALVE CLEARANCE CHECK AND ADJUSTMENT

No clearance check or adjustments are required. The FE400 engine is equipped with hydraulic lifters that automatically eliminate all clearance in the valve train components.

---

## CRANKCASE

---

**See General Warning, Section 1, Page 1-1.**

### ENGINE REMOVAL

To perform repairs on crankcase components, remove engine from the vehicle. **See following CAUTION.**

#### **CAUTION**

- Before removal and disassembly, clean the engine.

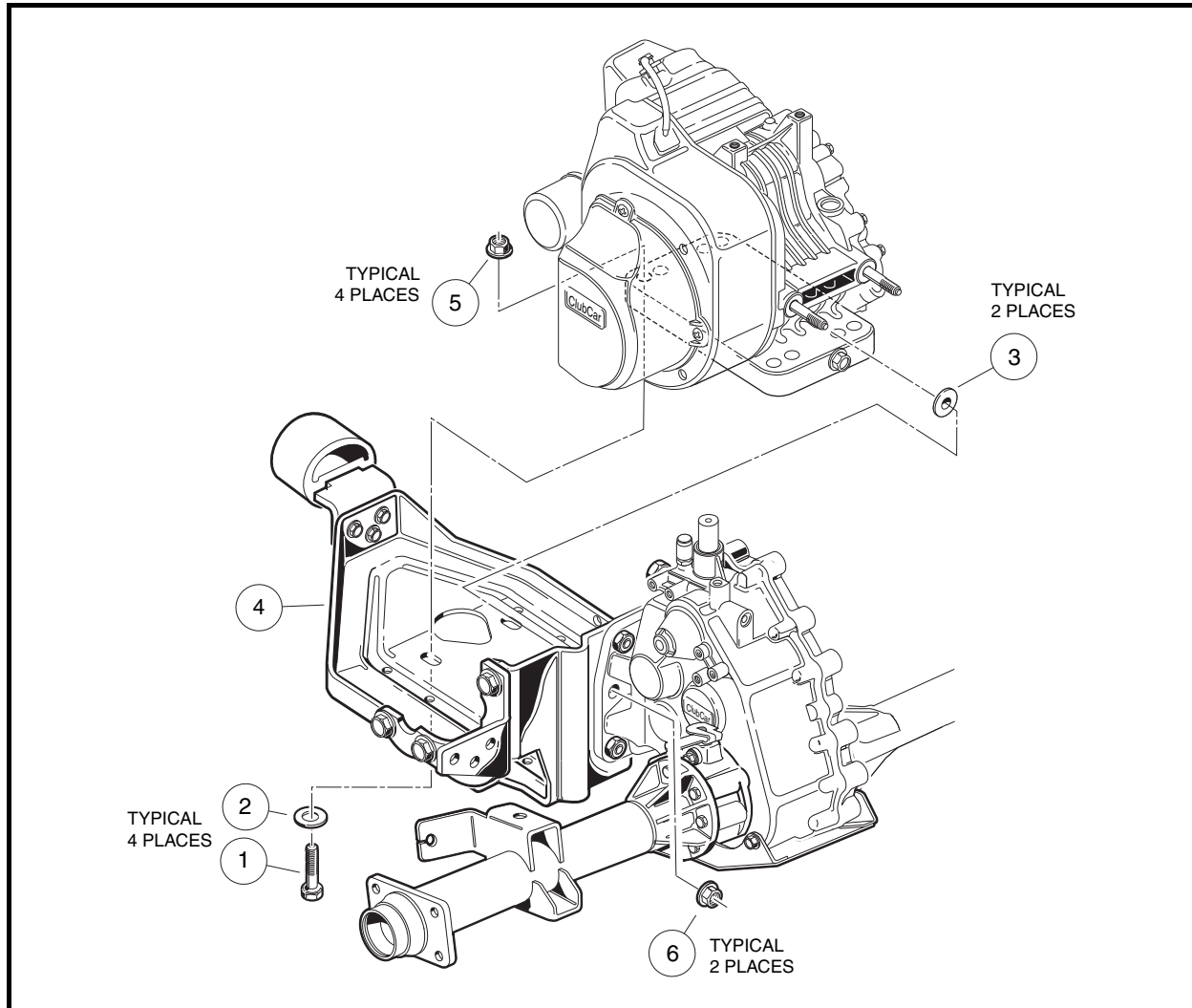
1. Remove the powertrain. **See Unitized Transaxle Removal, Section 16, Page 16-6. See following NOTE.**

**NOTE:** *The crankshaft has left-hand threads at the clutch mounting hole.*

2. Remove starter/generator. **See Starter/Generator (Model G425419), Section 12, Page 12-1.**
3. Remove drive clutch. **See Drive Clutch, Section 17, Page 17-4.**

**Engine Removal, Continued:**

4. Remove muffler. **See Muffler Removal, Section 15, Page 15-1.**
5. Remove engine mounting hardware (items 1, 2, 5 and 6) (**Figure 13-1, Page 13-4**).
6. Lift engine from the mounting plate.
7. Remove crankcase oil drain plug and filler tube. Tip the engine slightly to allow all of the oil to drain from the crankcase. Dispose of engine oil properly.



**Figure 13-1 Engine Mounting Plate - with MC012C-BS00 Transaxle**

**CRANKCASE COVER REMOVAL**

1. Remove yellow jumper wire (11) from cord connector (12) (**Figure 13-2, Page 13-5**).
2. Remove nuts and clamps at two-ended bolts (1 and 2) (**Figure 13-3, Page 13-5**).
3. Remove eight bolts (3) and remove the crankcase cover (4). **See following NOTE.**

**NOTE:** *If the crankcase cover sticks, tap lightly with a plastic mallet on alternate sides near the dowel pins (5) (**Figure 13-3, Page 13-5**).*

4. Remove the crankcase cover gasket completely. It may stick to the flanged surface of the crankcase.

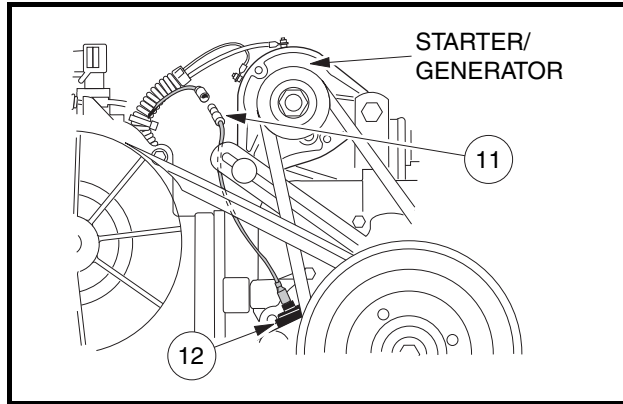


Figure 13-2 Oil Level Sensor Wire

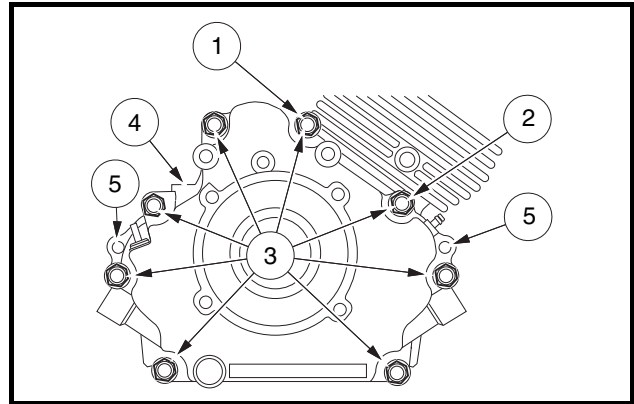


Figure 13-3 Crankcase Cover

## OIL LEVEL SENSOR

### Testing the Oil Level Sensor

See Test Procedure 21, Section 11, Page 11-32.

### Oil Level Sensor Removal

1. If not already removed, remove crankcase cover. **See Crankcase Cover Removal on page 13-4.**
2. Disconnect the oil level sensor wire (2) from the cord connection (1) (**Figure 13-4, Page 13-5**).
3. Remove the two mounting screws (8) from inside of the crankcase cover and remove the oil level sensor and bracket.

### Oil Level Sensor Installation

1. If the oil level sensor was removed from the bracket, install sensor (6) into bracket (5) and secure with three screws (7) and tighten to 17 in-lb (1.9 N·m) (**Figure 13-4, Page 13-5**).
2. Position the sensor and bracket on inside of crankcase and install two mounting screws (8).
3. Connect sensor wire (2) to cord connector (1) (**Figure 13-4, Page 13-5**).
4. Install screw (3) through wire clamp and into crankcase cover. Tighten to 30 in-lb (3.4 N·m).

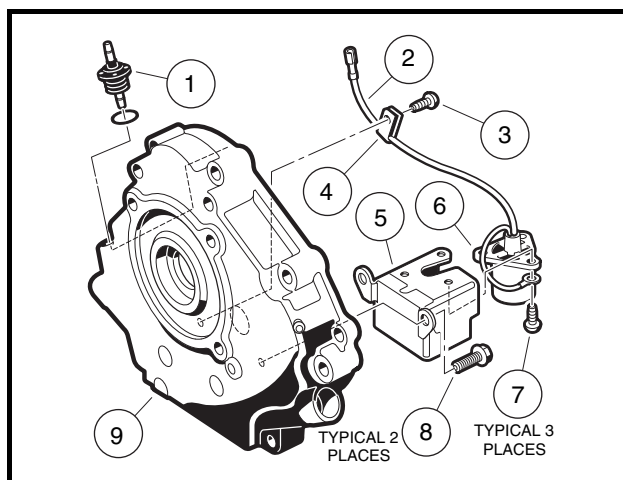


Figure 13-4 Oil Level Sensor

## IGNITION COIL AND FLYWHEEL

See General Warning, Section 1, Page 1-1.

### Ignition Coil and Flywheel Removal

1. Loosen three screws and remove the remaining four screws attaching the flywheel housing as shown, then remove the housing (**Figure 13-5, Page 13-6**).
2. Disconnect the ignition coil (1) from its primary lead wire at the connector (2). Remove the two bolts (3) and take out the ignition coil (**Figure 13-6, Page 13-6**).
3. Hold the flywheel (4), not the fan (7), with a strap wrench (5) and, using a 25 mm socket, remove the flywheel nut (and flat washer) by turning it counterclockwise (**Figure 13-7, Page 13-7**). See following **CAUTION**.

### CAUTION

- The flywheel nut has right-hand threads. Turn it clockwise to tighten, or counterclockwise to loosen.
  - Do not damage the fan blades with the strap wrench. Do not place screwdriver or pry bar in the fan blades.
4. Remove the flywheel with a puller.
  5. Remove the flywheel key from its groove.

### Flywheel Installation

See Flywheel Installation on page 13-7.

### Ignition Coil Inspection and Repair

See Test Procedure 16, Section 11, Page 11-24.

### Ignition Coil Installation

1. Installation is the reverse of removal.
2. Tighten the two bolts (3) and use a bronze feeler gauge to adjust the ignition coil air gap to 0.012 inch (0.304 mm) (**Figure 13-8, Page 13-7**).
3. Tighten the two ignition coil bolts to 30 in-lb (3.4 N·m).

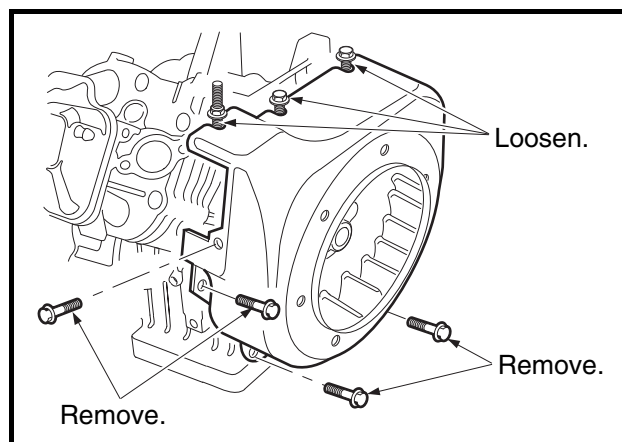


Figure 13-5 Flywheel Housing

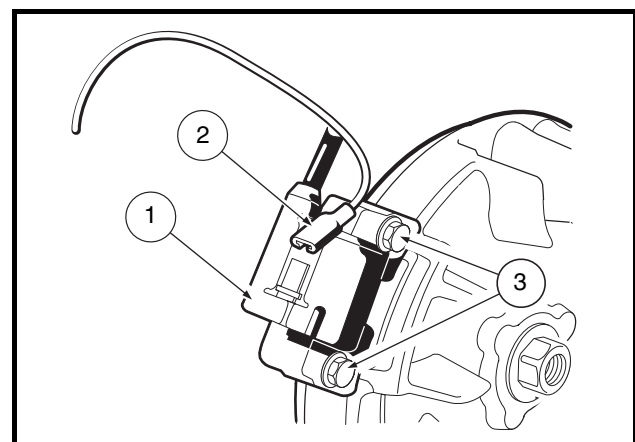


Figure 13-6 Ignition Coil

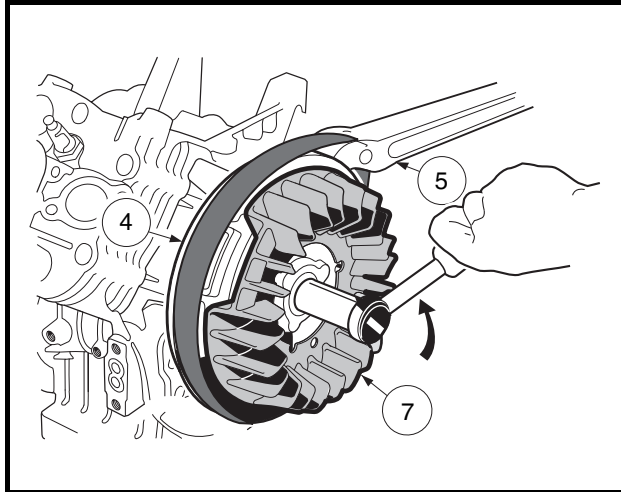


Figure 13-7 Flywheel Nut Removal

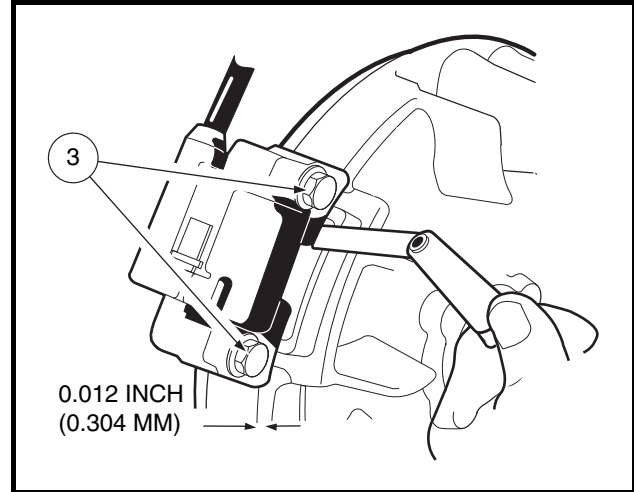


Figure 13-8 Adjust Ignition Coil Air Gap

## CRANKCASE COVER INSTALLATION

### **CAUTION**

- Before assembly, make sure parts are clean.
- Do not reuse the gasket. Install a new one.
- Install and tighten crankcase cover bolts as instructed. Failure to do so could cause the cover to become warped.

1. Clean the gasket surfaces on the crankcase cover to fit a new gasket during installation and inspect the oil seal for wear and damage.
2. Install crankcase cover. Using HANDS ONLY, seat cover completely against the crankcase.
3. Install and finger tighten evenly the eight cover mounting bolts (**Figure 13-9, Page 13-8**).
4. Tighten the cover mounting bolts in two steps. First, in the sequence shown, tighten all eight bolts to approximately 130 in-lb (14 N·m). Then, repeating the sequence, tighten them to 250 in-lb (28.2 N·m).

## FLYWHEEL INSTALLATION

See General Warning, Section 1, Page 1-1.

1. Connect the yellow jumper wire (11) to the cord connector (12) (**Figure 13-2, Page 13-5**).

### **CAUTION**

- Before assembly, make sure parts are clean.
2. Insert the flywheel key into the keyway in the crankshaft and align the flywheel keyway. Push the flywheel and fan onto the crankshaft until it seats. Install flat washer and nut finger-tight.
  3. Use a strap wrench (3) to keep the flywheel and fan (1) from turning. Tighten the flywheel nut to 63 ft-lb (85.4 N·m) (**Figure 13-10, Page 13-8**). See following CAUTION.

**Flywheel Installation, Continued:****CAUTION**

- The flywheel nut has right-hand threads. Turn it clockwise to tighten, or counterclockwise to loosen.
  - Be careful not to damage the fan blades. Use a strap wrench to hold flywheel. Do not place screwdriver or pry bar between fan blades.
4. Install the fan housing and tighten the seven screws to 90 in-lb (10 N·m).
  5. Install the fan shroud and tighten the four screws to 25 in-lb (2.8 N·m).

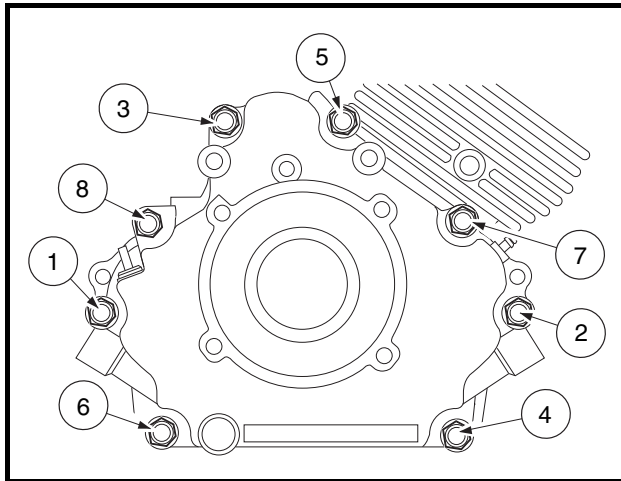


Figure 13-9 Crankcase Cover Installation

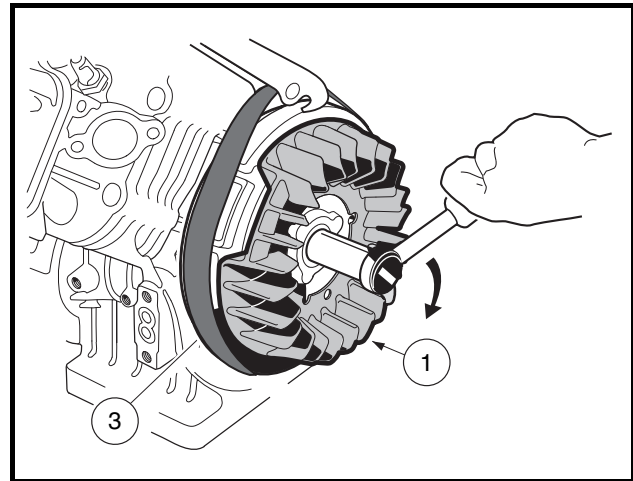


Figure 13-10 Fan and Flywheel Assembly

**ENGINE INSTALLATION**

1. Place engine onto engine mounting plate and tighten the mounting hardware (1, 2 and 5) to 13 ft-lb (18 N·m). Tighten nuts (6) to 17 ft-lb (23.1 N·m) (**Figure 13-1, Page 13-4**).
2. Install drive clutch. **See Drive Clutch Installation, Section 17, Page 17-11.**
3. Install drive belt. **See Drive Belt Installation, Section 17, Page 17-3.**
4. Install muffler. **See Muffler Installation, Section 15, Page 15-1.**
5. Install starter/generator and belt. **See Starter/Generator (Model G425419), Section 12, Page 12-1.**
6. Install the powertrain. **See Unitized Transaxle Installation, Section 16, Page 16-15.**
7. Install oil drain plug in the crankcase and tighten to 20 ft-lb (27.1 N·m). Apply a light film of oil on the seal of a new oil filter and install the filter on the crankcase. Fill the crankcase to the proper level with the correct type of oil (**Figure 13-12, Page 13-9**). **See Periodic Lubrication Schedule, Section 10, Page 10-3.**
8. Check all hardware for proper torque/tightness.
9. Check engine oil level (**Figure 13-11, Page 13-9**).
  - 9.1. Vehicle should be on a level surface when checking oil. Do not overfill.
10. Install a new or cleaned spark plug, gap 0.027 - 0.031 inch (0.69 - 0.79 mm).
11. Connect battery and spark plug wire(s). **See Connecting The Battery on page 1-3.**

12. Adjust the engine RPM setting. **See Engine RPM Adjustment, Section 14, Page 14-10.**
13. Test-drive vehicle to ensure all systems are functional and correctly adjusted.

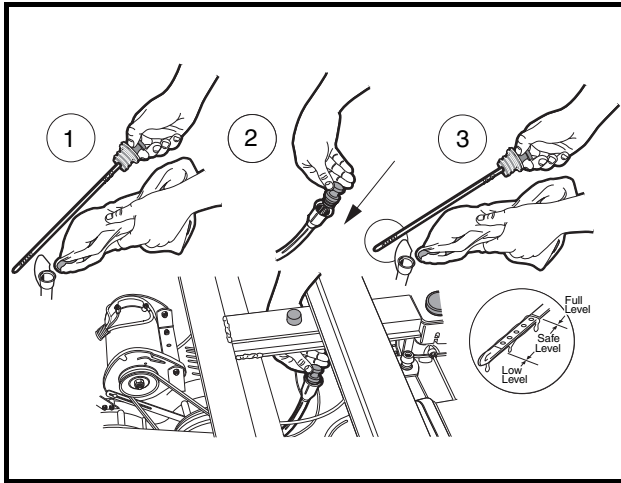


Figure 13-11 Check Engine Oil Level

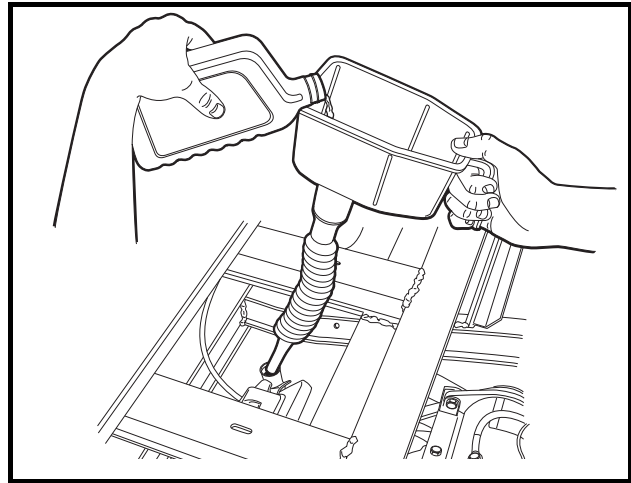


Figure 13-12 Add Engine Oil

## TORQUE SPECIFICATIONS

ITEM	SIZE	FE400 LIMITS
Flywheel retaining nut	M18	100 ft-lb (135 N·m)
Crankcase cover to block bolts	M8	22 ft-lb (31 N·m)
Starter/Generator bracket to block bolts	M8	16.5 ft-lb (23 N·m)
Oil drain plug	M14	16.5 ft-lb (23 N·m)
Fan housing screws	M6	90 in-lb (10 N·m)
Fan shroud screws	M6	25 in-lb (2.8 N·m)

## ADJUSTMENT AND SETTINGS

ITEM	SERVICE LIMIT FE400 ENGINE
Spark plug gap (standard)	0.027 to 0.031 in. (0.69 to 0.79 mm)
Ignition coil air gap (standard)	0.012 in. (0.304 mm)
Compression pressure (min.) (with automatic compression release)	71 psi (4.83 Bars)
Engine RPM	3850 (±30) RPM





# SECTION 14 – FUEL SYSTEM

---

## **▲ DANGER**

- See General Warning, Section 1, Page 1-1.

## **▲ WARNING**

- See General Warning, Section 1, Page 1-1.

## GENERAL INFORMATION

---

The FE400 engine is equipped with a float bowl type carburetor with fixed jets that require no adjustment. The size of the jets are determined by the altitude where the engine will be operating. The engines are equipped with the jets sized for the operating elevation at the time of manufacture.

## CARBURETOR

---

**See General Warning, Section 1, Page 1-1.**

Before suspecting the carburetor as the cause of poor engine performance, make sure the fuel and ignition systems are in proper operating condition. Check the following items:

- Spark plug and gap condition. **See Spark Plug, Section 13, Page 13-2.**
- Air filter element. **See Air Filter on page 14-18.**
- Fuel filters. **See Fuel Filters on page 14-18.**
- Choke and air intake system (for restriction of air flow). **See Choke and Air Intake System on page 14-12.**
- Fuel pump. **See Fuel Pump on page 14-19.**
- Fuel lines (from fuel tank to filter to pump to filter to carburetor). **See Fuel Lines on page 14-27.**
- Exhaust system (for restrictions). **See Section 15 – Exhaust System.**

If the carburetor floods or leaks fuel at the float bowl gasket or carburetor vent tube, the fuel inlet valve could be worn or dirty or have a damaged float that has filled with fuel and sinks.

The following chart lists the elevation ratings for various jet sizes. No adjustment is required for the pilot jet. If the vehicle idles rough, turn the pilot air screw out until the vehicle idles smoothly.

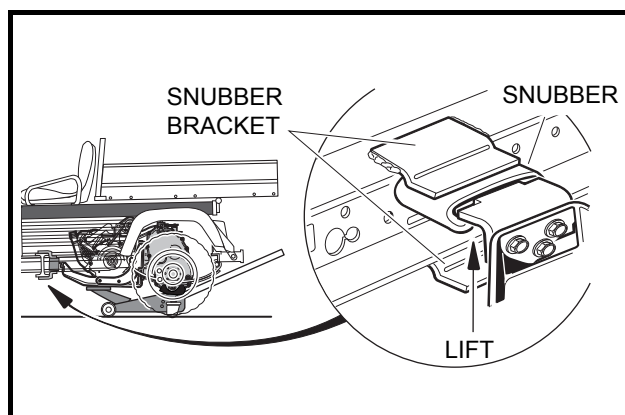
## MAIN JET ELEVATION/SIZE CHART

ALTITUDE	FE400 ENGINE MAIN JET SIZE
0-3280 ft. (0-1000 m)	88
3280-6562 ft. (1000-2000 m)	85
6562 ft. and over (2000 m and over)	82

## CHANGING THE MAIN JET

See General Warning, Section 1, Page 1-1.

1. Remove the carburetor (**Figure 14-2, Page 14-4**).
  - 1.1. Make sure the key switch is OFF and the Forward/Reverse handle is in the NEUTRAL position. Chock the wheels.
  - 1.2. Disconnect battery and spark plug wire(s). **See Disconnecting The Battery on page 1-3.**
  - 1.3. Turn fuel shut-off valve on gas tank to the closed (OFF) position.
  - 1.4. Loosen the intake air hose clamp (22) and disconnect the hose (23) at the carburetor end only (**Figure 14-2, Page 14-4**).
  - 1.5. Remove the Z-shaped end of the governor cable (carburetor end only).
  - 1.6. Disconnect the carburetor vent line (14).
  - 1.7. Disconnect the fuel supply line (26) at the carburetor end only. Temporarily plug the end of the fuel line to prevent fuel leakage.
  - 1.8. Chock the front wheels and place a floor jack under the engine mounting plate, and raise the engine until the front bracket snubber is fully compressed. This will allow the carburetor to pass the electrical box assembly. (**Figure 14-1, Page 14-2**).



**Figure 14-1 Compress Engine Snubber**

- 1.9. Remove the carburetor retaining nuts (19), intake pipe (17) and carburetor (12) (**Figure 14-2, Page 14-4**). **See following NOTE.**

**NOTE:** Note the orientation of the gasket (16), between the carburetor intake pipe (17) and the carburetor body (12) so that it can be replaced in the same orientation (**Figure 14-2, Page 14-4**).

Disconnect the throttle return spring (11). Note the orientation so that it can be replaced the same. The carburetor must be kept upright during removal.

2. Position the carburetor with the drain screw (11) over a catch basin (**Figure 14-3, Page 14-5**).
3. Drain all the fuel from the bowl into the catch basin. Tighten the drain screw to 10 in-lb (1.1 N·m) and return fuel to the fuel tank or dispose of properly.
4. Mark the body of the carburetor and the carburetor fuel bowl with an indelible ink marker so that, after removal, the bowl can be installed again in the same position.
5. Remove the carburetor fuel bowl retaining screw and washer (12), then remove the fuel bowl (10) and clean it with a nonflammable solvent. **See following NOTE.**

**NOTE:** Make sure the fuel bowl gasket (9) remains properly seated in the carburetor body when the fuel bowl is removed.

*During normal operation, the fuel bowl retains the float pivot pin (6). Make sure that the float pivot pin does not fall out of the carburetor body after the fuel bowl is removed.*

6. Remove the main jet (8) from the carburetor body and discard it.

**NOTE:** Keep the fuel nozzle (7) with the carburetor body after removal of the main jet by positioning the carburetor upside down during main jet removal.

7. Select the proper size main jet. **See chart on page 14-2.** Check the size designation on the jet to make sure it is the correct part.
8. Install the new main jet and tighten it to 12 in-lb (1.4 N·m). **See following CAUTION and NOTE.**

### **CAUTION**

- **Do not remove the valve/spring assembly from the float assembly. Doing so will damage the spring.**

**NOTE:** Inspect the main jet nozzle (7) and pilot jet (4) to ensure they are free from contamination. Replace any part that is clogged. Replace the float or float valve if damaged or worn. Confirm the float valve/spring assembly is installed correctly.

9. Install the fuel bowl and position with aligning marks applied in step 4. **See following CAUTION.**

### **CAUTION**

- **Make sure the fuel bowl is properly seated against the carburetor fuel bowl gasket, and the gasket is not pinched.**

10. Install the fuel bowl retaining screw and tighten it to 61 in-lb (6.9 N·m).
11. Write the size of the main jet on the fuel bowl with an indelible ink marker in a location that will be visible when the carburetor is installed on the engine.
12. Loosely attach the throttle return spring (11) to the carburetor throttle (12) and throttle bracket (4).
13. Install the carburetor (12), gasket (10), throttle spring (11), bracket (4), gaskets (1) and (3), and carburetor insulator (2) onto the manifold bolts (18) (**Figure 14-2, Page 14-4**).
14. Install the intake pipe gasket (16) (check for proper orientation) and intake pipe (17).
15. Attach the carburetor retaining nuts (19) and tighten them to 50 in-lb (5.7 N·m).
16. Lower the floor jack from under the engine mounting plate, allowing the front bracket snubber to return to normal condition (**Figure 14-1, Page 14-2**).
17. Connect fuel supply line (26) and tighten screw clamp to 9 in-lb (1.0 N·m) (**Figure 14-2, Page 14-4**).
18. Install carburetor vent line (14) and clamp (13).

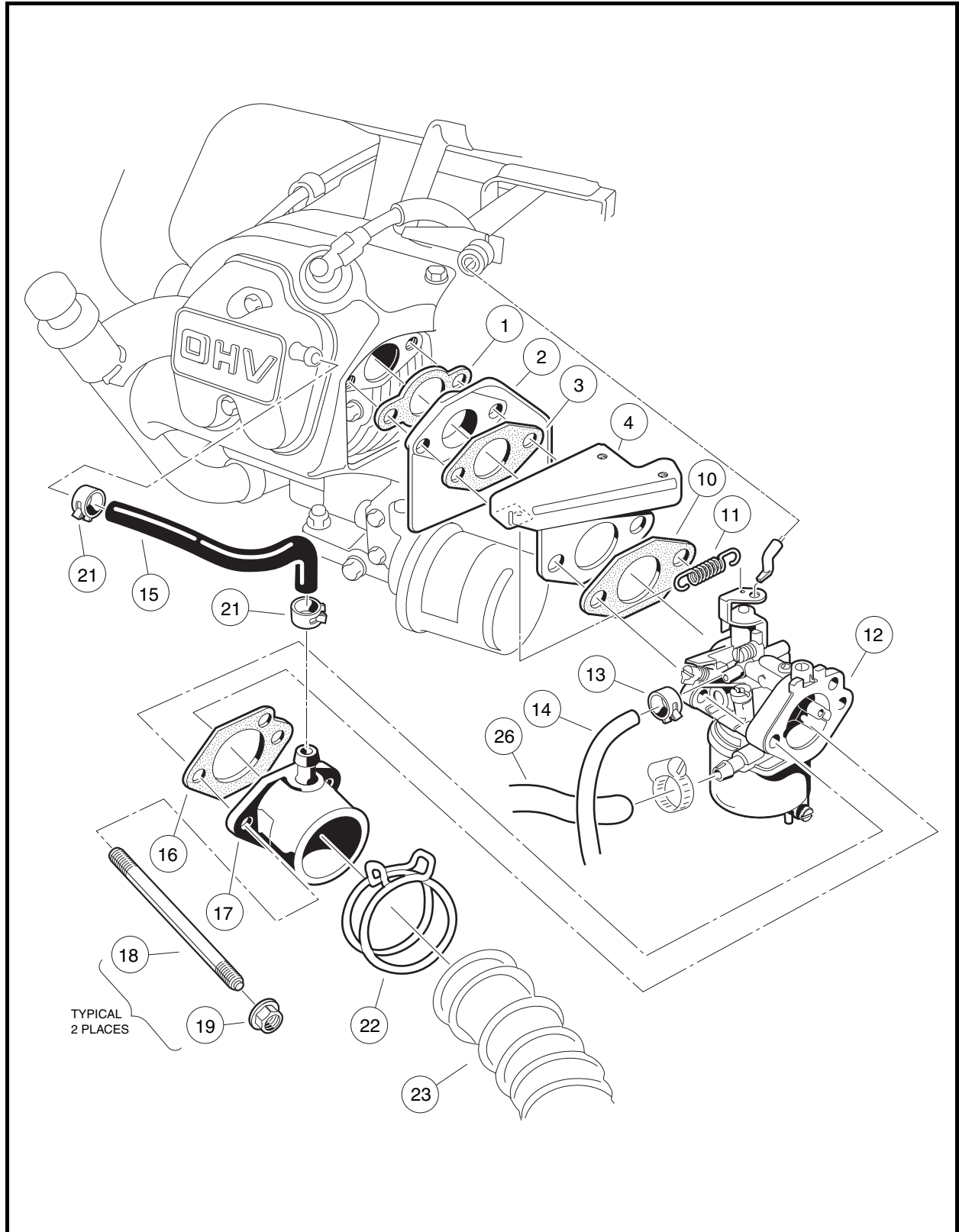


Figure 14-2 Carburetor Installation

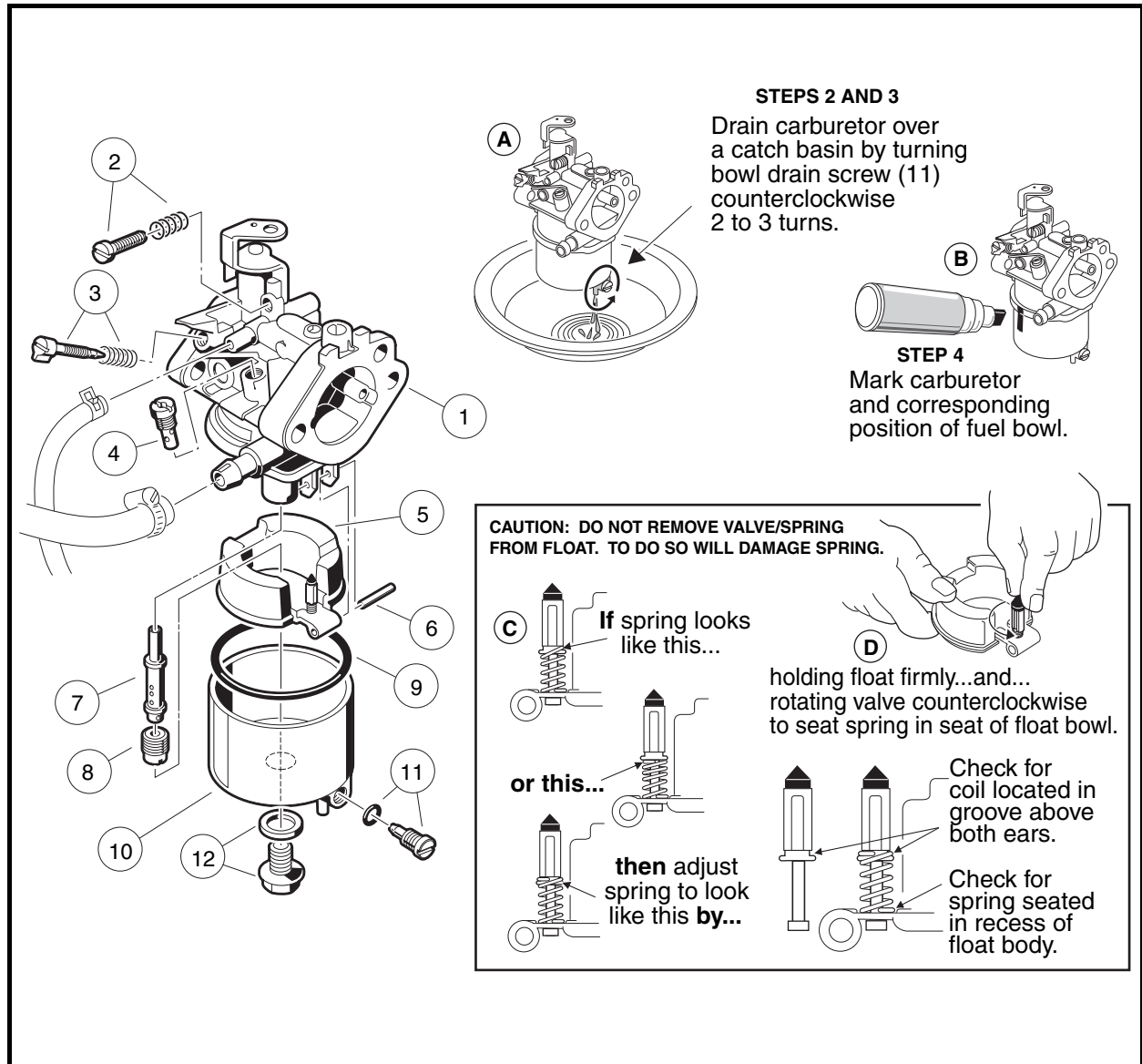


Figure 14-3 Changing the Main Jet

19. Install the Z-shaped end of the governor cable into the throttle bracket.
20. Install the intake hose (23) and secure with hose clamp (22) (Figure 14-2, Page 14-4).

**NOTE:** Make sure the intake hose is not twisted during installation.

21. Turn fuel shut-off valve (on fuel tank) to the ON position (Figure 14-20, Page 14-28, and Figure 14-21, Page 14-28).
22. Connect battery and spark plug wire(s). See Connecting The Battery on page 1-3.
23. Test drive the vehicle.

## ENGINE CONTROL LINKAGE

See General Warning, Section 1, Page 1-1.

### GENERAL INFORMATION

It is important that the accelerator pedal, governor linkage, and throttle adjustments are done correctly and in the proper sequence. See following **CAUTION**.

#### **CAUTION**

- Improper adjustment can result in poor vehicle performance and/or damage to the engine components.

### ACCELERATOR ROD

#### **DANGER**

- To ensure the vehicle does not run over you while you disconnect or adjust the accelerator push rod, do the following:
  - Turn key switch OFF, place Forward/Reverse handle in the NEUTRAL position and remove key before servicing the vehicle.
  - Disconnect battery and spark plug wire(s). See Disconnecting The Battery on page 1-3.

### Accelerator Rod Removal

1. Place chocks at the rear wheels and lift the front of the vehicle with a chain hoist or floor jack. Place jack stands under the outer front frame I-beam of the vehicle and lower onto stands. See **Figure 5-2, Section 5, Page 5-3**. See preceding **DANGER**. See **WARNING “Lift only one end...”** in **General Warning, Section 1, Page 1-1**.
2. Disconnect the ball joint (1) from the ball stud (2) on the accelerator pedal (**Figure 14-4, Page 14-6**) and from the bell crank at the electrical box (**Figure 14-6, Page 14-8**).

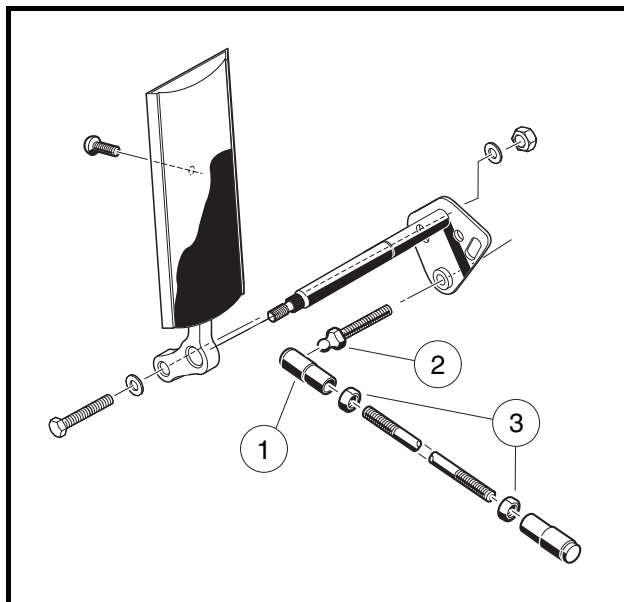


Figure 14-4 Accelerator Rod

## Accelerator Rod Installation and Adjustment

1. Turn the key switch to OFF and remove the key. Place the Forward/Reverse handle in the NEUTRAL position. Chock the wheels.
2. Adjust accelerator pedal position. **See Accelerator Pedal Adjustment, Section 5, Page 5-6.**
3. Install the ball joint on the ball stud at the accelerator pedal (**Figure 14-4, Page 14-6**).
4. Remove the air intake hose from the carburetor.
5. Remove the electrical box screw and cover.
6. With the ball joint jam nuts (3) loose (**Figure 14-4, Page 14-6**), adjust the length of the accelerator rod so the indicated cam edge is parallel with the edge of the electrical component box (**Figure 14-5, Page 14-8**). **See following CAUTION.**

### **⚠ CAUTION**

- **After accelerator rod adjustment, make sure that approximately the same number of threads are exposed at each end of the accelerator rod.**
7. Install the accelerator rod on the bell crank ball joint on the electrical component box (**Figure 14-6, Page 14-8**). **See following CAUTION and NOTE.**

### **⚠ CAUTION**

- **Inspect the limit switch inside the electrical box. If the limit switch lever is bent, replace the switch.**

**NOTE:** Use the inside hole location, or hole closest to the bell crank shaft as shown.

8. Confirm proper accelerator rod operation before tightening jam nuts:
  - 8.1. The carburetor throttle should begin to move when the pedal is pressed approximately 8° to 12°.
9. Tighten the jam nuts against the ball joints at each end of the accelerator rod, accelerator ball joint first, while holding the ball joints with pliers.
10. Check rod adjustment for proper switch activation.
11. Adjust the engine RPM setting. **See Engine RPM Adjustment on page 14-10.**
12. Install the electrical component box cover and tighten retaining screw to 18 in-lb (2.0 N·m).
13. Install the air intake hose onto the carburetor.

## GOVERNOR CABLE

### Governor Cable Removal

1. Turn the key switch OFF and remove the key. Place the Forward/Reverse handle in the NEUTRAL position. Chock the wheels
2. Remove the governor cable (8) from the engine bracket (19) and lift the Z-shaped cable end from the carburetor throttle bracket (**Figure 14-8, Page 14-11**).
3. Remove the cable from engine bracket (18) and lift the Z-shaped cable end from the governor bracket.

### Governor Cable Installation and Adjustment

1. Install the Z-shaped end into the governor bracket (18) and push cable down into bracket slot to secure. Be sure the bellows dust shield is attached (**Figure 14-8, Page 14-11**).

2. Install the Z-shaped end into carburetor throttle and push cable down into bracket (19) slot to secure. Be sure the bellows dust shield is attached.
3. Use a 1/8-inch punch or scratch awl to turn the governor arm shaft counterclockwise until it stops. Then pull the governor lever arm rearward until the carburetor throttle is in the "wide open throttle" (WOT) position.
4. Hold the arm and shaft in the fully counterclockwise position and tighten the governor arm lever nut to 36 in-lb (4.0 N·m).
5. Check engine RPM adjustment. **See Engine RPM Adjustment on page 14-10.**

## ACCELERATOR CABLE

### Accelerator Cable Removal

1. Turn the key switch OFF and remove the key. Place the Forward/Reverse handle in the NEUTRAL position. Chock the wheels.
2. Disconnect battery and spark plug wire(s). **See Disconnecting The Battery on page 1-3.**
3. Remove the air intake hose from the carburetor.
4. Remove the electrical component box cover and loosen the cable housing retaining nuts (**Figure 14-5, Page 14-8**).
5. Disconnect cable from cam in the electrical component box (**Figure 14-5, Page 14-8**).

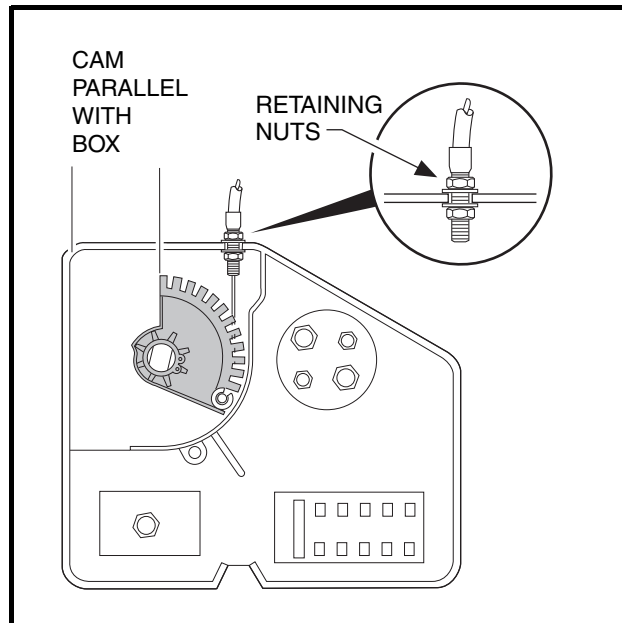


Figure 14-5 Cam Position

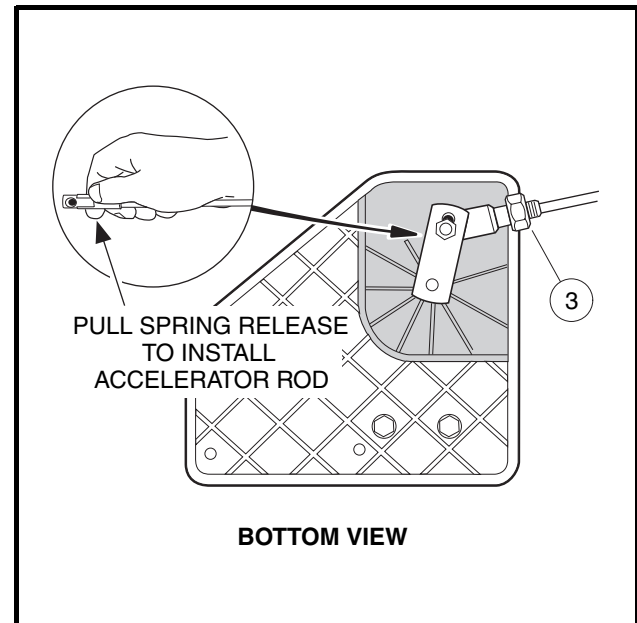


Figure 14-6 Accelerator Rod

6. Remove the accelerator cable (7) from the engine bracket (17) and lift the Z-shaped cable end from the bracket (**Figure 14-8, Page 14-11**).
7. Disconnect the spring (16) from the engine governor arm by rotating the arm counterclockwise one-half turn. Remove the cable assembly from the vehicle.

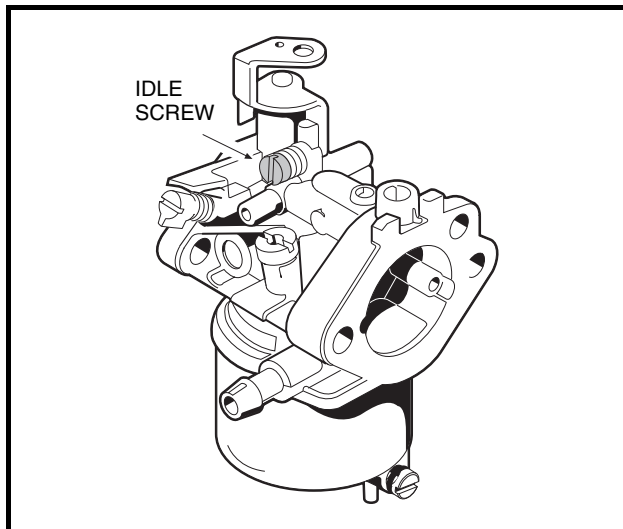


## Accelerator Cable Installation

1. Connect the accelerator cable (7) to the cam in the electrical box (**Figure 14-8, Page 14-11**).
2. Insert the cable housing into the mounting slot in the wall of the electrical box, with approximately the same number of threads visible between the jam nuts as are visible from the nut inside the box to the end of the cable housing (**Figure 14-5, Page 14-8**). Tighten the nuts finger-tight.
3. Connect the spring (16) to the engine governor arm (**Figure 14-8, Page 14-11**).
4. Install cable (7) in accelerator cable bracket (17) and push down to snap into bracket slot to secure.
5. Confirm that the engine RPM adjustment is correct. **See Engine RPM Adjustment on page 14-10.**
6. Install the electrical component box cover, and tighten the retaining screw to 18 in-lb (2.0 N·m).
7. Install the air intake hose onto the carburetor.
8. Connect battery and spark plug wire(s). **See Connecting The Battery on page 1-3.**

## CLOSED THROTTLE OR IDLE ADJUSTMENT

1. With the engine running and the Forward/Reverse handle in the NEUTRAL position, attach a tachometer (CC P/N 1016112) to the spark plug wire and adjust the low idle screw on the carburetor until the tachometer reads 1200 to 1250 RPM (**Figure 14-7, Page 14-9**).



**Figure 14-7 Idle Screw**

## ENGINE RPM ADJUSTMENT

### **DANGER**

- **Do not operate gasoline vehicle in an enclosed area without proper ventilation. The engine produces carbon monoxide, which is an odorless, deadly poison.**
1. Adjust the governor, then proceed to step 2. **See Governor Cable Installation and Adjustment on page 14-7.**
  2. Connect battery and spark plug wire(s). **See Connecting The Battery on page 1-3.**
  3. Place the Forward/Reverse handle in the NEUTRAL position. Chock the wheels.
  4. With the engine running at normal operating temperature, position a tachometer (CC P/N 1016112) close to the spark plug wire and plug and adjust the high speed RPM. With the accelerator pedal pressed to the floor, the tachometer should read:
    - 4.1. After the accelerator pedal and rod are adjusted, the final governed engine RPM should be set to 3850 ( $\pm 30$ ) RPM.
  5. To reduce RPM, loosen the accelerator cable retaining nut on the outside of the electrical box wall and tighten the retaining nut on the inside of the wall until the specified RPM is reached (**Figure 14-5, Page 14-8**). To increase RPM, loosen the cable retaining nut inside the electrical box and tighten the nut outside the box until the desired RPM is reached.
  6. Be sure both retaining nuts are locked against the electrical box and then check the RPM again. If the RPM needs to be adjusted, repeat step 4.
  7. If more adjustment is required than the cable housing will allow, make sure the spring on the other end of the accelerator cable is properly positioned. Excessive belt and torque converter wear can also prevent proper RPM adjustment. Check them for excessive wear. **See Section 17 – Torque Converter.**

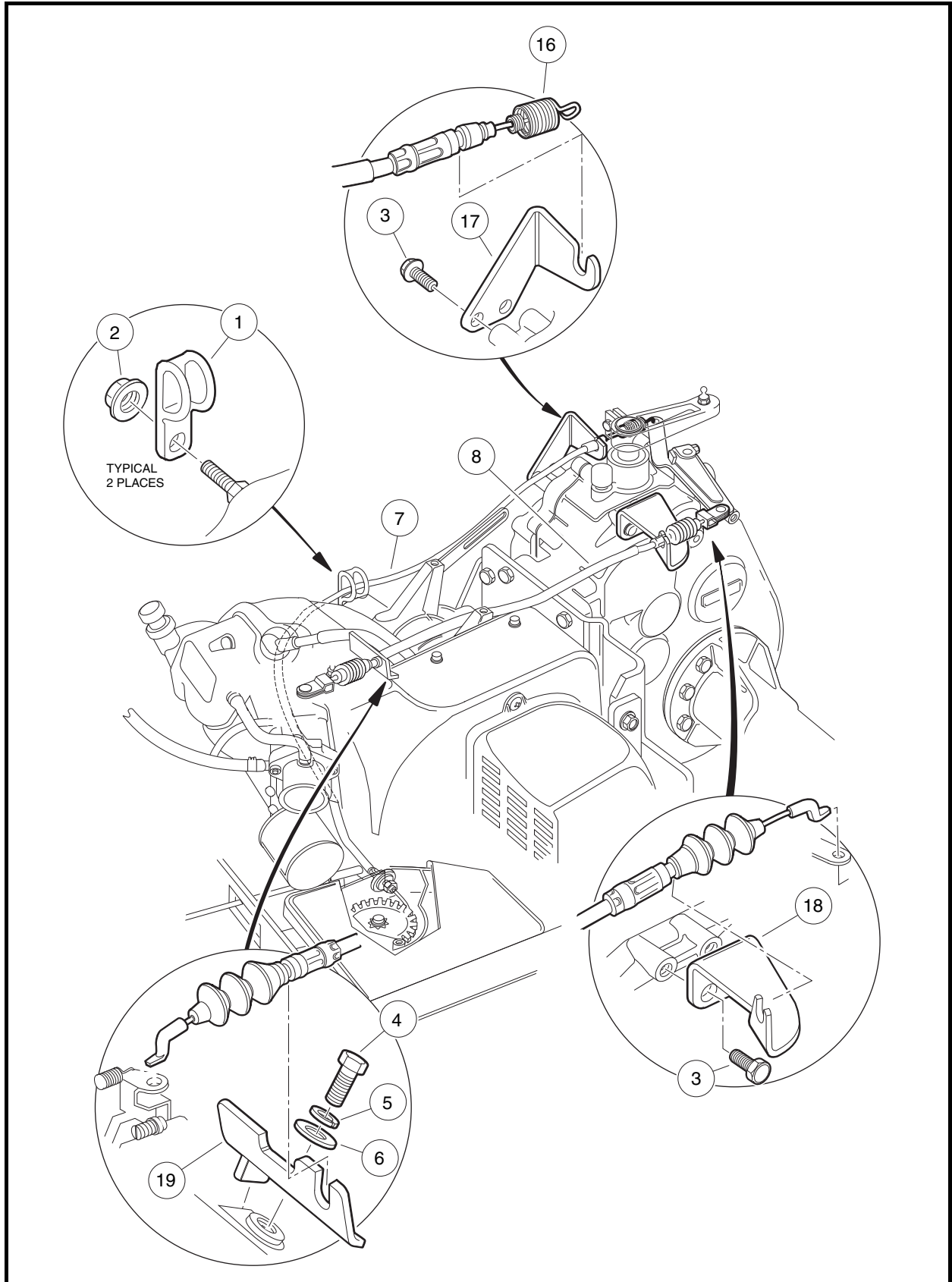


Figure 14-8 Governor and Accelerator Cables

## CHOKE AND AIR INTAKE SYSTEM

---

See General Warning, Section 1, Page 1-1.

### CHOKE CABLE REMOVAL

1. Turn the key switch to OFF and remove the key. Place the Forward/Reverse handle in the NEUTRAL position. Chock the wheels.
2. Remove the screw (17) securing cable to air box and detach cable end from choke lever (6) (**Figure 14-10, Page 14-15 or Figure 14-11, Page 14-16**).
3. Remove three screws (19), nuts (21) and washers (20) from body and remove choke cable assembly from body.
4. **Carryall 472/XRT 1200 SE:**
  - 4.1. Cut wire tie (23) around cable and air duct (**Figure 14-11, Page 14-16**).

### CHOKE CABLE INSTALLATION

1. Insert choke cable through hole in body until choke lever assembly seats against body.
2. Install three screws (19), washers (20), and locknuts (21) (**Figure 14-10, Page 14-15 or Figure 14-11, Page 14-16**). Tighten to 18 in-lb (2.0 N·m).
3. Check the hex nut on the cable at the back of the choke lever assembly and tighten it until the lockwasher beside it collapses completely.
4. Attach choke cable to choke lever (6) on air box top (4) and install screw (17) to secure cable to air box. Tighten screw to 18 in-lb (2.0 N·m).
5. **Carryall 472/XRT 1200 SE:**
  - 5.1. Attach a new wire tie (23) around the cable and air duct (**Figure 14-11, Page 14-16**).

### AIR BOX REMOVAL

1. Turn the key switch OFF and remove the key. Place the Forward/Reverse handle in the NEUTRAL position. Chock the wheels.
2. Remove choke cable bracket screw (17) and cable (18) from air box top (4) (**Figure 14-10, Page 14-15 or Figure 14-11, Page 14-16**).
3. **Turf 272/Carryall 272/XRT 1200:**
  - 3.1. Remove air intake box (12) from the vehicle by removing hose clamp (15), intake hose (16), three screws (23) and washers (22) (**Figure 14-10, Page 14-15**).
4. **Carryall 472/XRT 1200 SE:**
  - 4.1. Remove air intake box (12) from the vehicle by removing hose clamp (15), intake hose (16), three screws (25) and washers (24) (**Figure 14-11, Page 14-16**).

### AIR BOX INSTALLATION

**NOTE:** The intake duct must be in place before the air box can be installed.

1. Check to be sure the intake seal (13) is tightly seated (**Figure 14-10, Page 14-15 or Figure 14-11, Page 14-16**). The seal fits tightly onto the bottom side of the air box. If seal is not in place, moisture will enter the air intake system.
2. **Turf 272/Carryall 272/XRT 1200:**
  - 2.1. Place air box assembly into vehicle and install three flat washers (22) and screws (23) from underside of air box mounting plate into air box (12) (**Figure 14-10, Page 14-15**). Tighten to 33 in-lb (3.7 N·m).

- 2.2. Place hose (16) onto air box top (4) and secure with wire clamp (15).
- 2.3. Attach choke cable (18) to the air box top (4). **See Choke Cable Installation on page 14-12.**
3. **Carryall 472/XRT 1200 SE:**
  - 3.1. Place air box assembly into vehicle and install three flat washers (24) and screws (25) from underside of air box mounting plate into air box (12) (**Figure 14-11, Page 14-16**). Tighten to 33 in-lb (3.7 N·m).
  - 3.2. Place hose (16) onto air box top (4) and secure with wire clamp (15).
  - 3.3. Attach choke cable (18) to the air box top (4) **See Choke Cable Installation on page 14-12.**
4. Test choke for proper operation.

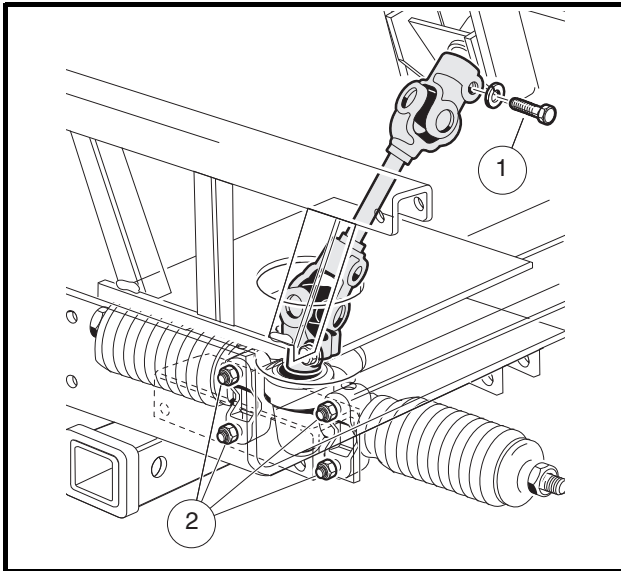


Figure 14-9 Compound Steering Joint

## INTAKE DUCT REPAIR

If the intake duct is badly torn or has large holes, it will need to be replaced.

## INTAKE DUCT REMOVAL

**NOTE:** This procedure is best accomplished using two people.

1. Turn the key switch OFF and remove the key. Place the Forward/Reverse handle in the NEUTRAL position. Chock the wheels.
2. **Turf 272/Carryall 272/XRT 1200:**
  - 2.1. Remove the front body. **See Front Body Removal, Section 4, Page 4-5.**
  - 2.2. Slightly loosen the lug nuts on the both front wheels.
  - 2.3. Raise the front of the vehicle with a floor jack.
  - 2.4. Place jack stands under the vehicle outer front frame I-beam and lower onto jack stands. **See Figure 5-2, Section 5, Page 5-3. See WARNING “Lift only one end...” in General Warning, Section 1, Page 1-1.**
  - 2.5. Remove the front wheels.
  - 2.6. Remove the bolt (1) that connects the steering joint to the steering column shaft (**Figure 14-9, Page 14-13**). **See following NOTE.**

**NOTE:** The bolt must be removed completely before the splined coupling can be separated.

Make an alignment mark on the steering column shaft and the steering joint for use during replacement.

- 2.7. Remove the four bolts and locknuts (2) from the rack and pinion assembly mount and gently disconnect the steering joint from steering column shaft at the bolt (1) location (**Figure 14-9, Page 14-13**). Gently allow both the rack and pinion assembly and the steering column shaft to drop down, remaining suspended between both rod ball joint ends.
- 2.8. Remove the two bolts (26), locknuts and flat washers that secure the top of the strap plate (27) to the vehicle frame (**Figure 14-10, Page 14-15**).
- 2.9. Remove the two bolts (28) and nuts that connect the upper shock mounts to the shock tower and bottom of the strap plate (27). Remove the strap plate. **See following CAUTION.**

### **⚠ CAUTION**

- **When removing the two bottom bolts (28) from the strap plate and shock tower, the A-arm assemblies will drop. It's best to have one person hold the front brake drum assembly while a second person removes each bolt from their respective shock and shock tower, and gently allow the A-arm assembly to rest in a suspended condition.**
- 2.10. Roll the floormat from underneath the dashboard and drill out the one bottom pop rivet (30) that secures the air intake shield (29) to the floorboard.
  - 2.11. Use a putty knife or other thin bladed device and gently pry apart the adhesive strip that holds the shield to the vehicle frame. **See following NOTE.**

**NOTE:** It may become necessary to re-form the shield prior to installation.

- 2.12. Remove the shield (29) from the vehicle frame.
  - 2.13. Drill out the pop rivet (24) securing the top of the intake duct to the floorboard (**Figure 14-10, Page 14-15**).
  - 2.14. Remove the air box assembly. **See Air Box Removal on page 14-12.**
  - 2.15. Lift air box assembly off the intake duct. Be careful that the intake seal on the bottom of the air box assembly is not dislodged in the process.
  - 2.16. Pull the intake duct forward, and out of the vehicle.
- 3. Carryall 472/XRT 1200 SE:**
- 3.1. Remove the air box assembly (**Figure 14-11, Page 14-16**). **See Air Box Removal on page 14-12.**
  - 3.2. Lift rear floor mat on the drivers side and drill out pop rivets (27) and remove strap (14).
  - 3.3. Cut wire tie (23) holding Forward/Reverse cable and choke cable to the air duct under the vehicle.
  - 3.4. Slide the air duct toward the front of the vehicle and down until it clears the chassis plate.

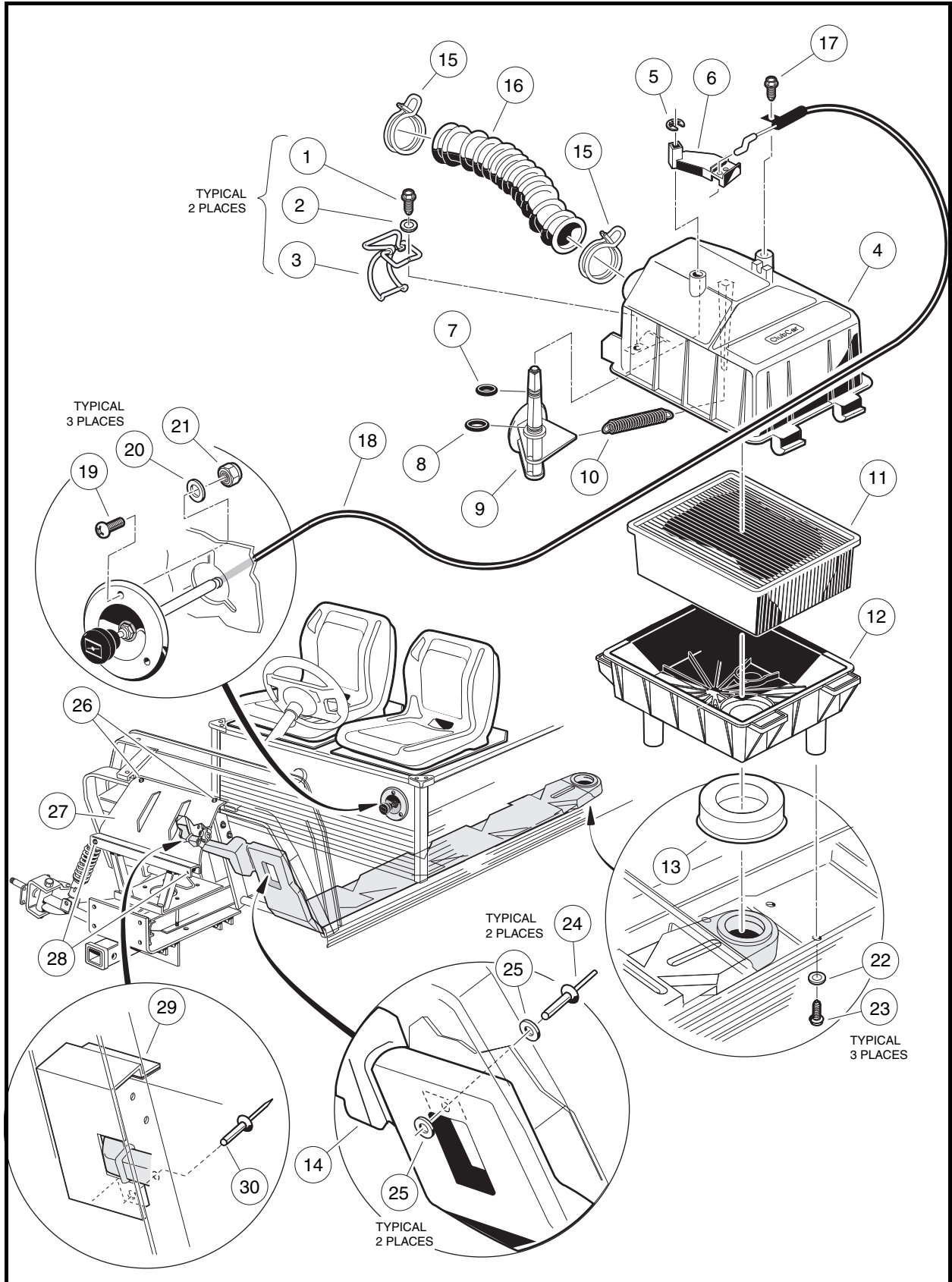


Figure 14-10 Turf 272/Carryall 272/XRT 1200 Air Intake and Choke Assemblies

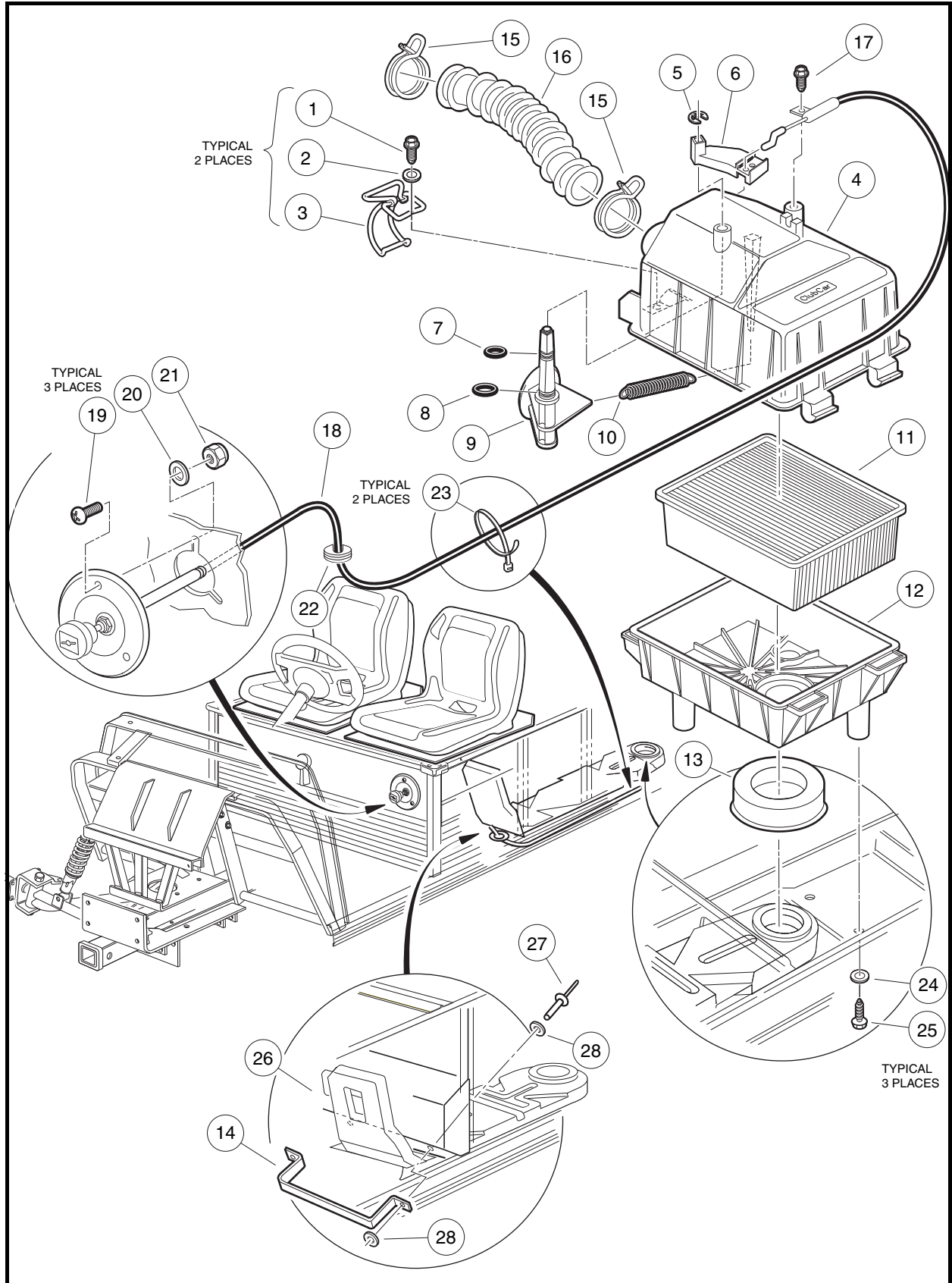


Figure 14-11 Carryall 472/XRT 1200 SE Air Intake and Choke Assemblies



## INTAKE DUCT INSTALLATION

**NOTE:** The intake duct assembly is installed from the front of the vehicle, in reverse order of removal. This procedure is best accomplished using two people. **See following NOTE.**

1. Slide the intake duct between the round crossmember and the floorboard, moving it to the rear along the underside of the floorboard. **See following NOTE.**

**NOTE:** It is best to have a second person guide the air box end of the duct into position as it is pushed from the front of the vehicle. Insert the end of the intake duct through the slot in the front of the air box mounting plate.

2. Secure the front of the duct to the underside of the floorboard with pop rivet (24) and flat washers (25) (**Figure 14-10, Page 14-15**).
3. Place a piece of double-sided adhesive tape on the intake shield and remove the adhesive backing. **See following NOTE.**

**NOTE:** If necessary reform any minor deformation of the shield and clean the old double-sided adhesive tape cleanly from both the shield and vehicle frame before installation of the shield.

4. Install the shield to the frame with the adhesive strip and pop rivet (30).
5. Install air box. **See Air Box Installation on page 14-12.**
6. Assemble front end components. **See following NOTE.**

**NOTE:** This procedure is best accomplished using two people.

- 6.1. Attach each of the front A-arms to the shock tower at the top shock mount and bottom hole locations of the strip plate (27) using bolts (28) and locknuts. Do not tighten (**Figure 14-10, Page 14-15**).
- 6.2. Position the top edge of the strap plate (27) onto the frame and install the two bolts (26), flat washers and locknuts. Do not tighten.
- 6.3. Tighten bolts (28) at the shock tower and strip plate (27) to 20 ft-lb (27 N·m).
- 6.4. Tighten bolts (26) at the top of the strip plate (27) and frame to 20 ft-lb (27 N·m).
- 6.5. Install steering joint. **See following NOTE.**

**NOTE:** Make sure steering wheel and front wheels are properly aligned before installing steering joint.

*The steering column shaft has a machined flat area provided for passage of the bolt when assembled to the steering joint.*

- 6.6. Slip the splined steering joint over the splined steering column shaft, aligning with the mark made during disassembly. Attach the bolt (1) through the steering joint flange and loosely attach the nut (**Figure 14-9, Page 14-13**).
- 6.7. Attach the rack and pinion assembly to the shock tower plate using the four bolts (2) and locknuts (**Figure 14-9, Page 14-13**). Tighten to 20 ft-lb (27 N·m).
- 6.8. Tighten the bolt (1) of the steering joint flange to 15 ft-lb (20.3 N·m).

### 7. Carryall 472/XRT 1200 SE:

- 7.1. Slide the rear portion of the air duct up under the rear floor board area and through the opening provided in the bottom of the engine compartment.
  - 7.2. Attach strap (14) on each end with 3/16-inch x 1/2-inch pop rivets (27) and washers (28) (**Figure 14-11, Page 14-16**).
  - 7.3. Attach a long wire tie (23) around the air duct body, Forward/Reverse cable, and choke cable, positioning the cables between the air duct and vehicle frame.
  - 7.4. Install air box. **See Air Box Installation on page 14-12.**
8. Install the front wheels and tighten the wheel lug nuts finger-tight.

9. Lower the vehicle and tighten the wheel lug nuts, using a crisscross pattern, to 55 ft-lb (75 N·m) for steel wheels or 65 ft-lb (88 N·m) for alloy mag wheels.
10. Install front body. **See Front Body Installation, Section 4, Page 4-5.**
11. Check for proper operation.

## AIR FILTER

### General Information

The air filter should be checked every year or 100 hours. More frequent service may be required in extremely dirty operating environments. Need for immediate servicing will be indicated by a loss of power, sluggish acceleration or an engine that runs rough with excessive black exhaust smoke.

### Air Filter Replacement

1. Turn the key switch OFF and remove the key. Place the Forward/Reverse handle in the NEUTRAL position. Chock the wheels.
2. Lift two latches (3) on the side of the air box (**Figure 14-10, Page 14-15 or Figure 14-11, Page 14-16**).
3. Remove the hose clamp (15) from the air hose and remove hose from the air box assembly.
4. Stand on the driver side of vehicle, grasp air hose mounting inlet and open and remove filter element (11).
5. Wipe away any dust or dirt from inside the air box with a clean cloth. Remove all dirt build-up around the inside lip of the box.
6. Install new air filter seat evenly onto inside lip of air box. Ensure filter fits correctly and that the wire latches are not caught between lid and air box.
7. Fasten wire latches (3) and make sure latches securely engage the bottom half of the box. **See following CAUTION.**

### CAUTION

- **Engine damage will occur if the air box cover is not properly secured.**
  - **If air box is extremely dirty, remove air box from vehicle and clean thoroughly.**
  - **Use only Club Car replacement air filters (CC P/N 1015426). The use of other air filters could result in engine damage. If the air filter is too thin, the cover will seat before the filter can seal, leaving space for dirt to pass into the engine on all sides of the element. This will damage the engine and void the warranty.**
8. Install hose (16) and hose clamp (15) and make sure clamp ends are located in the 12:00 o'clock position (**Figure 14-10, Page 14-15 or Figure 14-11, Page 14-16**).

## FUEL FILTERS

### See General Warning, Section 1, Page 1-1.

***NOTE:** 2009 and 2010 model year vehicles do not necessarily have a secondary fuel filter. The secondary fuel filter was determined to be unnecessary due to a change in the assembly process and thus eliminated.*

One or two in-line filters are installed between the fuel tank and the carburetor (**Figure 14-16, Page 14-24 or Figure 14-17, Page 14-25**). Fuel filters, fuel lines and the fuel tank vent should be inspected periodically for leaks and replaced when necessary with filter changes not to exceed two years or 200 hours.

### FUEL FILTER REMOVAL

1. Turn the key switch OFF and remove the key. Place the Forward/Reverse handle in the NEUTRAL position. Chock the wheels.

2. Disconnect battery and spark plug wire(s). **See Disconnecting The Battery on page 1-3.**
3. Turn the fuel shut-off valve (15) on the gas tank to the closed (OFF) position (**Figure 14-20, Page 14-28 or Figure 14-21, Page 14-28**).
4. Remove the primary fuel filter (17) (**Figure 14-16, Page 14-24 or Figure 14-17, Page 14-25**).
  - 4.1. Remove clamps (16) and fuel lines (1 and 2). Remove the filter and plug the fuel lines (1 and 2).
5. If equipped, remove the secondary filter (22).
  - 5.1. Remove clamps (16) from fuel lines (3 and 4). Remove the filter and plug the fuel lines (3 and 4).

## FUEL FILTER INSTALLATION

### **CAUTION**

- **Fuel filters are marked with flow direction arrows. Make sure that filters are installed with arrows pointing in the direction of fuel flow from tank to carburetor.**

1. Install the primary fuel filter (17) in reverse of removal. Use new clamps (16) (**Figure 14-16, Page 14-24 or Figure 14-17, Page 14-25**).
2. If equipped, install the secondary fuel filter (22) in reverse of removal. Use new clamps (16).
3. Turn the fuel shut-off valve to the ON position (**Figure 14-20, Page 14-28**).
4. Connect battery and spark plug wire(s). **See Connecting The Battery on page 1-3.**
5. Start the engine and check for fuel leaks. **See following DANGER.**

### **DANGER**

- **Repair any fuel leaks before operating the vehicle.**

## FUEL PUMP

**See General Warning, Section 1, Page 1-1.**

***NOTE:** A plastic fuel pump replaced the metal fuel pump during the 2010 model year. This plastic pump can not be disassembled and must be replaced.*

## GENERAL INFORMATION

If the fuel pump is not operating properly, perform the following tests:

- Make sure all hose clamps are tight.
- Inspect the impulse line and fuel lines for damage or clogging.
- Make sure the air vent on the fuel pump is not clogged with dirt. **See following NOTE.**
- Make sure the fuel filters are not clogged.

***NOTE:** To clean the air vent, the fuel pump must be disassembled (metal pump) or replaced (plastic pump).*

## FUEL PUMP REMOVAL

1. Turn the key switch OFF and remove the key. Place the Forward/Reverse handle in the NEUTRAL position. Chock the wheels.
2. Disconnect battery and spark plug wire(s). **See Disconnecting The Battery on page 1-3.**

3. Turn fuel shut-off valve on top of the gas tank to the closed (OFF) position (**Figure 14-20, Page 14-28 or Figure 14-21, Page 14-28**).
4. Remove hardware (25) attaching the fuel pump (18) and lift the fuel pump out of the engine compartment (**Figure 14-16, Page 14-24 or Figure 14-17, Page 14-25**).
5. Remove the clamp (20) and impulse line (7) from fuel pump.
6. Remove the clamps (16) and fuel lines (2 and 3) from the pump. Plug lines to prevent gasoline leakage. **See following WARNING.**

### **⚠ WARNING**

- Carefully drain any fuel remaining in the pump into a container. Add drained fuel back into gas tank or dispose of properly.

## FUEL PUMP DISASSEMBLY (METAL PUMP ONLY)

**NOTE:** A fuel pump rebuild kit is available from Club Car (CC P/N 1014524).

1. Remove four screws (24) and lockwashers (25) from front of the fuel pump (**Figure 14-12, Page 14-20**).
2. Remove the front cover of the fuel pump while holding the rest of the pump intact.
3. Note the orientations of the impulse gasket (27), the diaphragm (28) and the gasket (29), then remove them from the pump. **See following CAUTION.**

### **CAUTION**

- Fuel pump gaskets and diaphragms must be installed in exactly the same positions and orientations they were in before disassembly, or the pump could leak. If leaking occurs, all new gaskets and diaphragms must be installed.

4. Remove the pumping chamber (30).
5. Remove the back cover (36), the fuel diaphragm (34) and gasket (35).

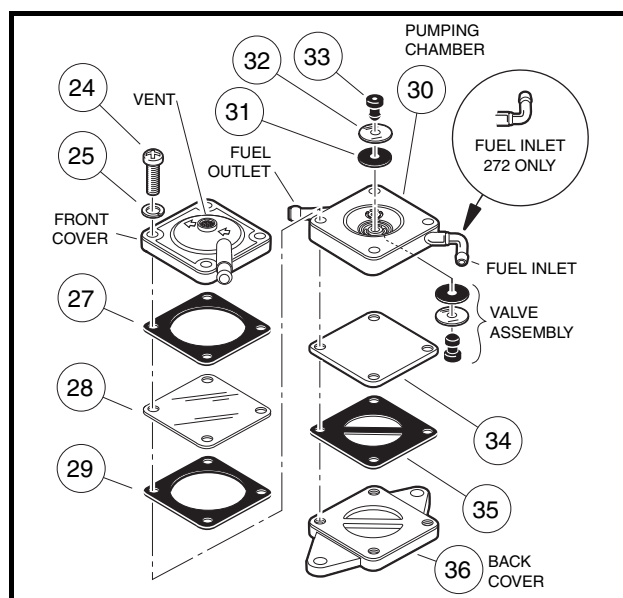


Figure 14-12 Fuel Pump

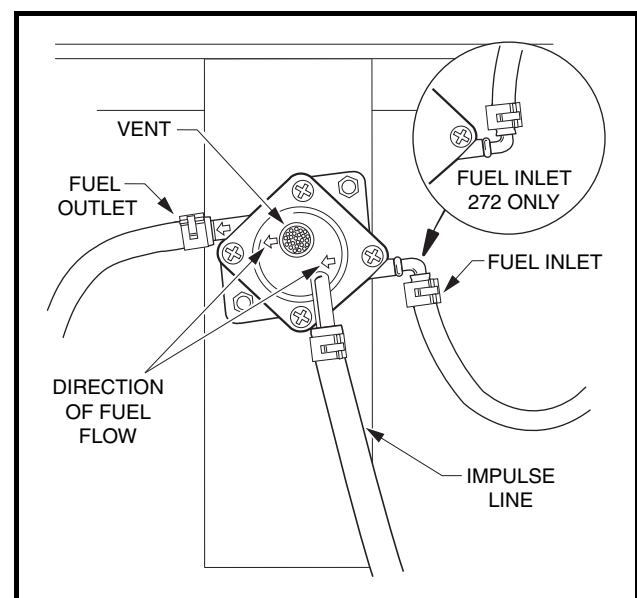


Figure 14-13 Fuel Pump Mount

## FUEL PUMP CLEANING AND INSPECTION (METAL PUMP ONLY)

1. Use a nonflammable solvent to clean the front cover, pumping chamber and back cover. Be sure the vent on the front cover is clean both inside and out.
2. Inspect the valve assemblies (31, 32, and 33), gaskets and diaphragms for damage (**Figure 14-12, Page 14-20**).
3. If a valve assembly is damaged, the rubber retaining plug (33) and valve assembly must be replaced.

## FUEL PUMP ASSEMBLY (METAL PUMP ONLY)

1. Install the fuel gasket (35) and diaphragm (34) on the back cover (36) (**Figure 14-12, Page 14-20**).
2. Install the valve assembly in the pumping chamber (30). **See following CAUTION.**

### **CAUTION**

- **If the valve assembly is not installed exactly as shown, the impulse fuel pump will not operate properly.**
3. Install the pumping chamber (30) on top of the fuel diaphragm (34). Be sure the fuel inlet and the fuel outlet align with the arrows on the front of the front cover (**Figure 14-12, Page 14-20**).
  4. Install the gasket (29), clear impulse diaphragm (28) and the paper impulse gasket (27) to the pumping chamber (30).
  5. Install the front cover and then the lockwashers (25) and four screws (24) on the assembly. Be sure the arrows on the front cover point from the fuel inlet to the fuel outlet (**Figure 14-13, Page 14-20**). Tighten the screws to 26 in-lb (3.0 N·m).

## FUEL PUMP INSTALLATION

1. Connect the fuel line (2) that comes from the fuel filter (17) to the fuel pump (18). Install a new clamp (16) (**Figure 14-16, Page 14-24 or Figure 14-17, Page 14-25**). **See same figure for proper routing of fuel lines. See following NOTE.**

**NOTE:** Be sure to connect the fuel line (2), that comes from the primary fuel filter (17), to the inlet nipple on the pump. Direction of fuel flow is indicated by the arrows on the fuel pump.

2. Connect the fuel line (3) to the fuel pump (18) that goes to the secondary fuel filter (22). Install a new clamp (16).
3. Connect the impulse line (7) to the bottom nipple on the fuel pump (18). Use a new clamp (20).
4. Install the fuel pump onto the mounting bracket with two thread-rolling screws (25) and tighten to 40 in-lb (4.5 N·m).
5. Turn the fuel shut-off valve on top of the gas tank to the open position (**Figure 14-20, Page 14-28**).
6. Connect battery and spark plug wire(s). **See Connecting The Battery on page 1-3.**
7. With the Forward/Reverse handle in the NEUTRAL position, start the engine and check for fuel leaks. If the fuel pump leaks, a rebuild kit or new fuel pump must be installed to replace all gaskets and diaphragms, or entire pump. **See following DANGER.**

### **DANGER**

- **Repair any fuel leaks before using the vehicle.**

## FUEL TANK

See General Warning, Section 1, Page 1-1.

### **⚠ WARNING**

- If the fuel tank is damaged, replace it. Do not attempt to repair it. See the following tank removal and disposal procedure.

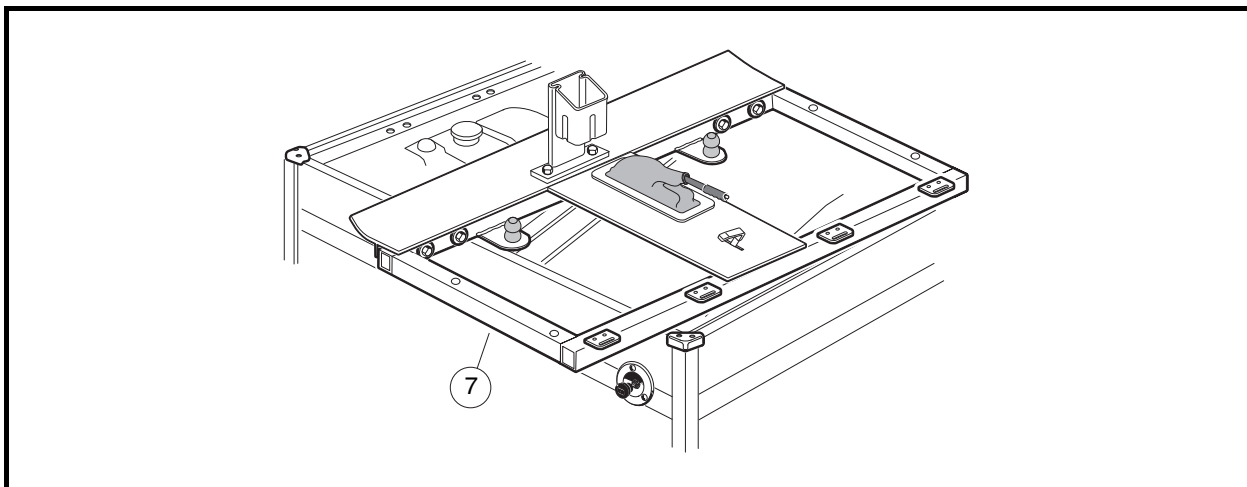
### **CAUTION**

- Add only unleaded gasoline to the tank. Do not put oil into the fuel tank.

## FUEL TANK REMOVAL

1. Turn the key switch to OFF and remove the key. Place the Forward/Reverse handle in the NEUTRAL position. Chock the wheels.
2. Turn fuel shut-off valve to the closed (OFF) position (**Figure 14-20, Page 14-28 or Figure 14-21, Page 14-28**).
3. Run the engine until fuel remaining in the carburetor, fuel pump and fuel lines is used up and the engine stalls.
4. Disconnect battery and spark plug wire(s). **See Disconnecting The Battery on page 1-3.**
5. Remove the four bolts (8), eight washers (9) and four locknuts (10) from the seat support and remove the two armrests (11 and 12) from the vehicle. **See Figure 4-3, Section 4, Page 4-8.**
6. Carefully remove and rotate the seat support (7) 90° clockwise and allow it to rest on the vehicle body (**Figure 14-14, Page 14-22**). **See following NOTE.**

**NOTE:** It is not necessary to remove the park brake cable or differential lock cable to service or remove the fuel tank.



**Figure 14-14 Seat Support Removal**

7. Loosen, but do not remove, the carburetor drain screw (11) (**Figure 14-3, Page 14-5**) and drain fuel remaining in the carburetor bowl into an approved container.
8. Use a siphon with a suction device and siphon all fuel out of the tank and into an approved container. **See following DANGER and WARNING.**

**⚠ DANGER**

- Gasoline! Flammable! Explosive! Do not smoke. Keep sparks and flames away from the vehicle and service area.

**⚠ WARNING**

- Never attempt to siphon fuel using a hose that does not have a built-in suction device.
- Never attempt to siphon fuel using your mouth.

9. Disconnect the black wire and orange wire from the fuel level sending unit on the tank (Figure 14-15, Page 14-23). Do not remove the lower nut on the center stud of the sending unit. See following WARNING.

**⚠ WARNING**

- Make sure the key switch is OFF and key removed before disconnecting wiring.

10. Loosen clamp (16) and remove the fuel line (1) from fuel tank shut-off valve (15) (Figure 14-16, Page 14-24 or Figure 14-17, Page 14-25).
11. Loosen clamp (7) and remove vent tube (6) from the fuel tank.
12. Turf 272/Carryall 272/XRT 1200:
  - 12.1. Loosen the straps (13 and 10) by removing screws (12 and 14) from the speed nuts (11) (Figure 14-16, Page 14-24).
13. Carryall 472/XRT 1200 SE:
  - 13.1. Loosen the strap (13) by removing nut (12) from J-bolt (8) (Figure 14-17, Page 14-25).
14. Lift the fuel tank out of the vehicle.

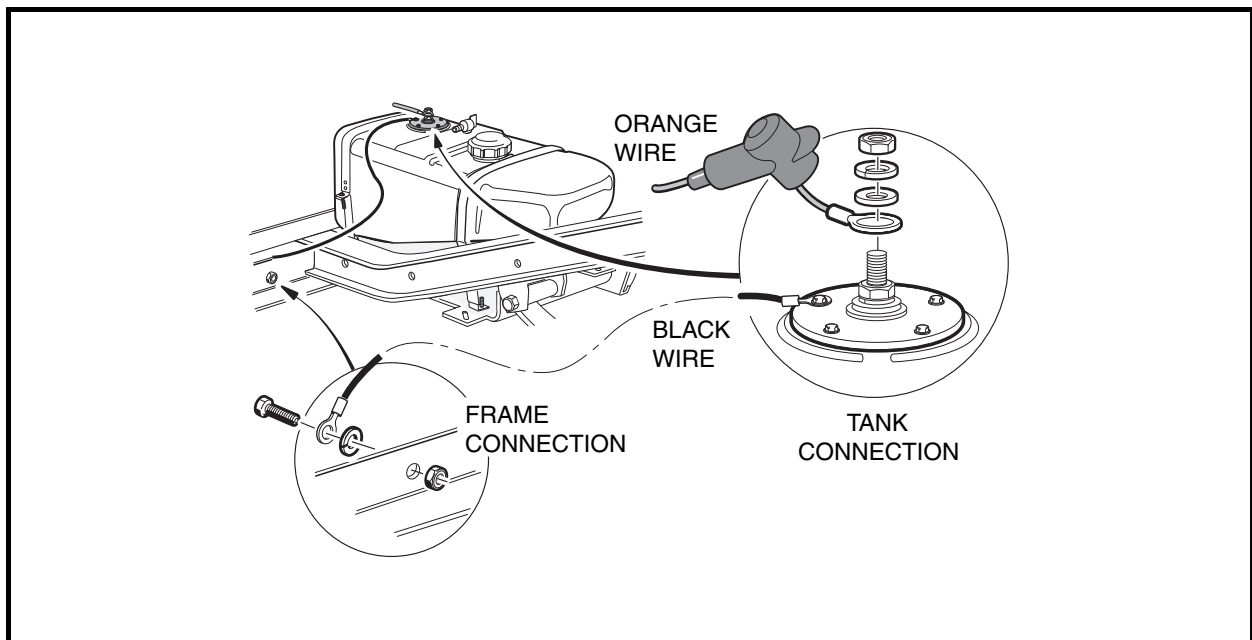


Figure 14-15 Fuel Level Sending Unit

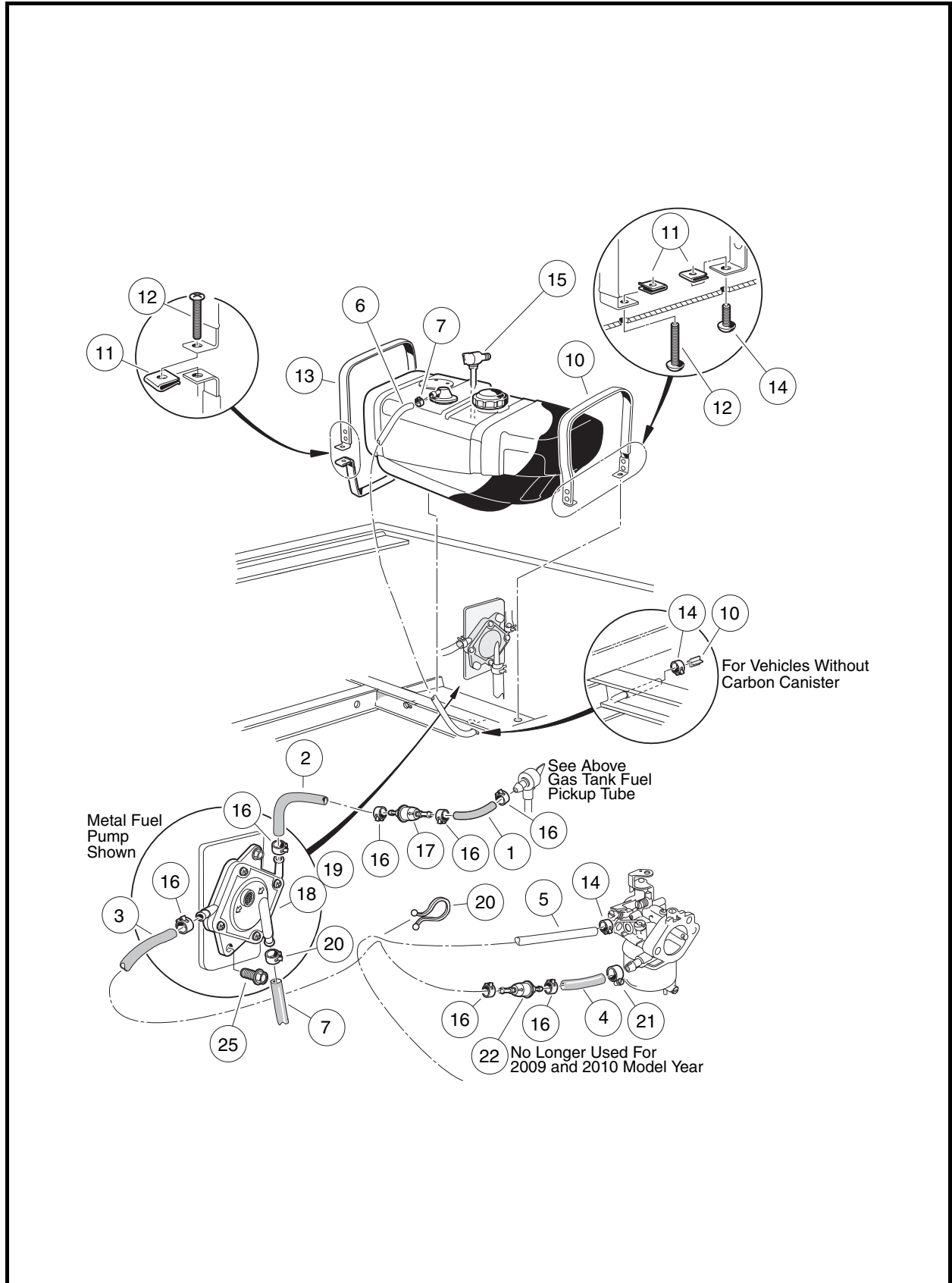


Figure 14-16 Turf 272/Carryall 272/XRT 1200 Fuel and Vent Lines



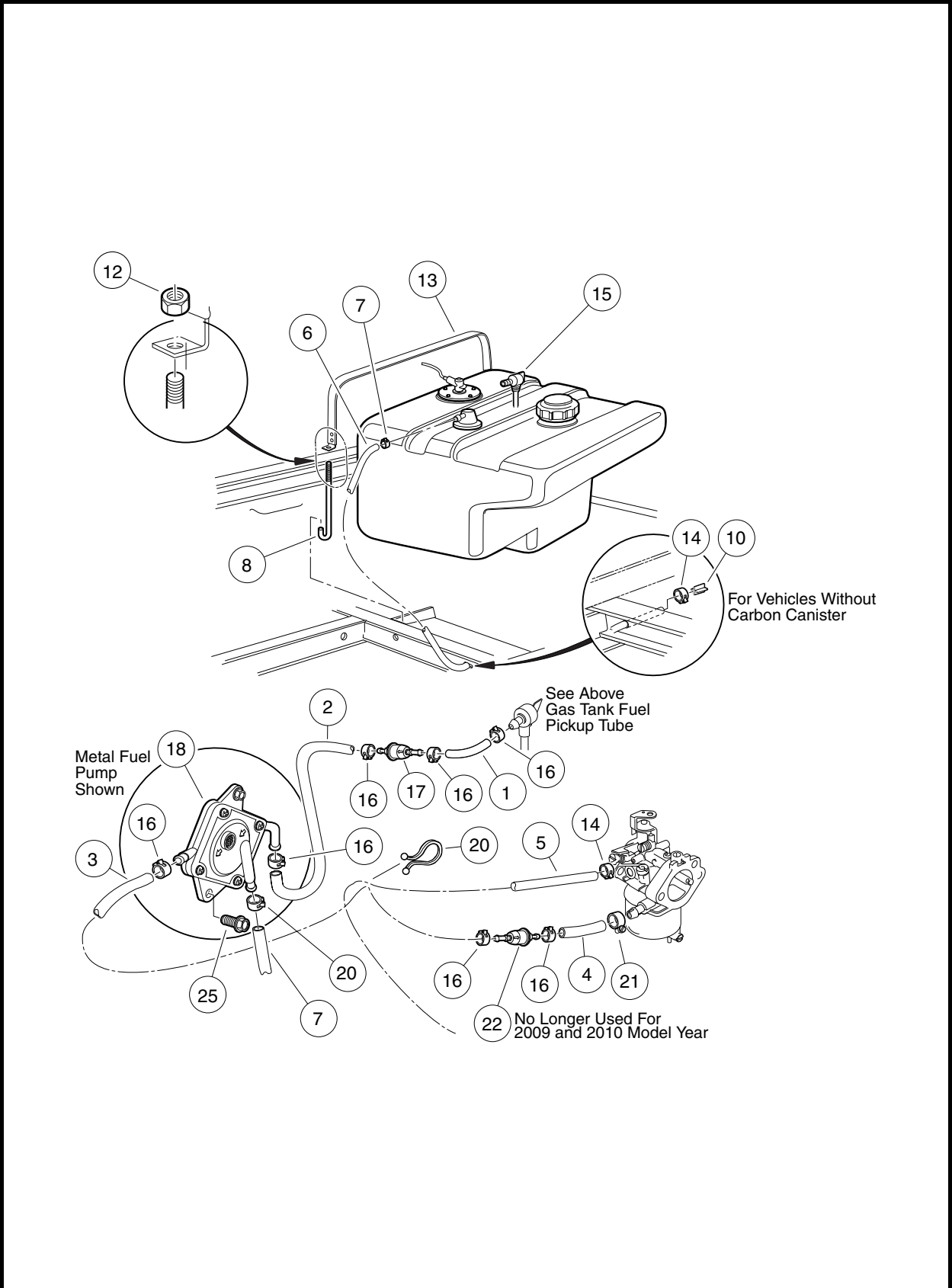


Figure 14-17 Carryall 472/XRT 1200 SE Fuel and Vent Lines

## FUEL TANK STORAGE OR DISPOSAL

1. Remove the cap from the tank and thoroughly rinse it with water. The cap may be discarded or kept as a spare.
2. Flush the fuel tank with water to remove any remaining gasoline. Use a well-ventilated area.
3. Set the tank upside down so that the water can drain. Use a well-ventilated area. Allow the tank to sit for 24 hours to dry. **See following WARNING.**

### **⚠ WARNING**

- **Dispose of wastewater and fuel tank in accordance with federal, state and local laws and ordinances.**
4. Store the tank upside down, with the cap installed. Use a well-ventilated area.

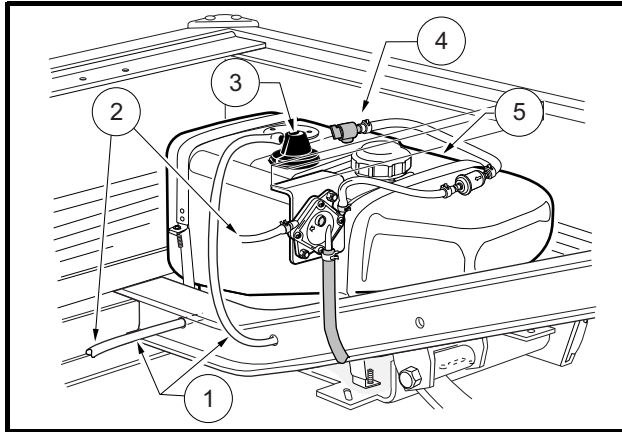
## FUEL TANK INSTALLATION

1. **Turf 272/Carryall 272/XRT 1200:**
  - 1.1. Position the retaining straps (13 and 10) and install the fuel tank (**Figure 14-16, Page 14-24**).
    - 1.1.1. Position the straps in the indentions on the tank.
  - 1.2. Install the screws (12 and 14) into the speed nuts (11) and tighten screws to 25 in-lb (2.8 N·m) (**Figure 14-16, Page 14-24**).
2. **Carryall 474/XRT 1200 SE:**
  - 2.1. Position the retaining strap (13) and install the fuel tank (**Figure 14-17, Page 14-25**).
  - 2.2. Install the nut (12) onto the J-bolt (8) and tighten to 25 in-lb (2.8 N·m).
  - 2.3. Return the seat support (1) to its original position by rotating it 90° counterclockwise (**Figure 14-14, Page 14-22**).
  - 2.4. Install the seat support and seat handles and tighten bolts (8) to 13 ft-lb (17.6 N·m). **See Figure 4-3, Section 4, Page 4-8.**
3. Connect the vent tube (6) to the gas tank vent (**Figure 14-16, Page 14-24 or Figure 14-17, Page 14-25**).
4. Connect fuel line (1) to the fuel tank shut-off valve (15). Use a new clamp.
5. Connect the black wire from the fuel gauge to one of the fuel level sending unit screws. Connect the orange wire to the center stud and install the flat washer, lockwasher and nut and tighten to 18 in-lb (2.0 N·m) (**Figure 14-15, Page 14-23**).
6. Slide the rubber boot over the stud.
7. Check the park brake and differential lock lever for proper adjustment and operation.
8. Add gasoline to the fuel tank.
9. Connect battery and spark plug wire(s). **See Connecting The Battery on page 1-3.**
10. Check to be sure the fuel shut-off valve on top of the gas tank is in the open (ON) position (**Figure 14-20, Page 14-28 and Figure 14-21, Page 14-28**).
11. Start the engine and allow it to idle. **See following DANGER.**

### **⚠ DANGER**

- **The engine produces carbon monoxide, which is an odorless, deadly poison. Do not operate the engine in an enclosed area without proper ventilation.**
- **After installing the fuel tank and adding gasoline, carefully check all fuel lines and connections for leaks. Repair any leaks before using the vehicle.**

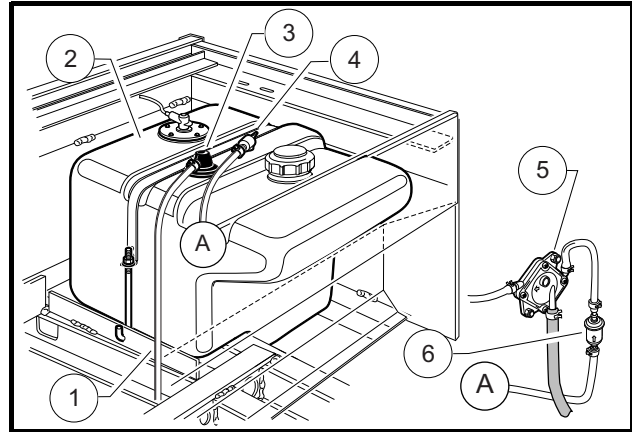
12. Allow the engine to run for a few minutes to ensure that the fuel lines are full of fuel.
13. Inspect each fuel line for leaks.
  - 13.1. Check all of the fuel line clamps at the carburetor, fuel filters, fuel pump and fuel tank for leaks.
  - 13.2. Inspect each fuel line to ensure that the lines are not cracked, cut or worn.
14. Turn the key switch to OFF.



**Figure 14-18 Turf 272/Carryall 272/XRT 1200 Fuel System**

1. Vent Tube\* 2. To Carburetor 3. Vent 4. Fuel Shut-off Valve 5. Fuel Tank

\*Vehicle without carbon canister shown.



**Figure 14-19 Carryall 472/XRT 1200 SE Fuel System**

1. Vent Tube 2. Fuel Tank 3. Vent 4. Fuel Shut-off Valve 5. Fuel Pump (under rear seat) 6. Fuel Filter (under rear seat)

## FUEL LINES

### See General Warning, Section 1, Page 1-1.

The fuel lines must be properly routed, and all hose clamps must be tight. The fuel lines should be kept clean. See following **WARNING**.

### **⚠ WARNING**

- **Make sure fuel lines are the right length and are properly routed. Failure to heed this warning could result in damage to fuel lines and fire.**

Fuel line no. 1 runs directly from the fuel tank to the primary fuel filter (17). Arrow indicates flow (**Figure 14-16, Page 14-24 or Figure 14-17, Page 14-25**).

Fuel line no. 2 runs directly from the primary fuel filter (17) to the fuel inlet of the fuel pump (18).

Fuel line no. 3 runs directly from the fuel outlet of the fuel pump (18) to the secondary fuel filter (22), if equipped. Arrow indicates flow. If vehicle is not equipped with secondary fuel filter (22), fuel line no. 3 runs directly to the carburetor.

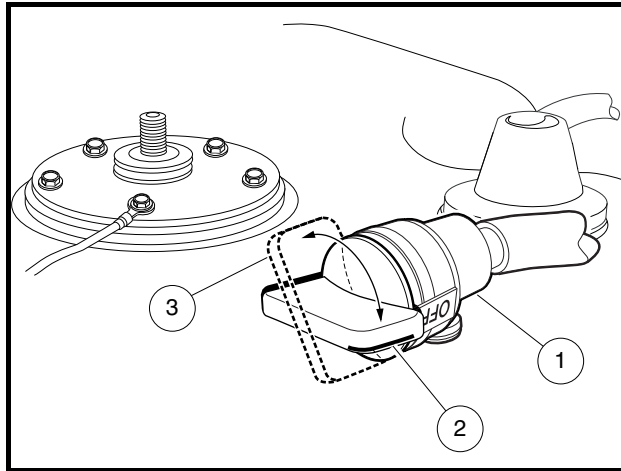
**For vehicles equipped with a secondary fuel filter only:** Fuel line no. 4 runs from the outlet of the secondary fuel filter (22) to the carburetor. Arrow indicates flow.

A screw band clamp should be used at the carburetor.

## FUEL SHUT-OFF VALVE

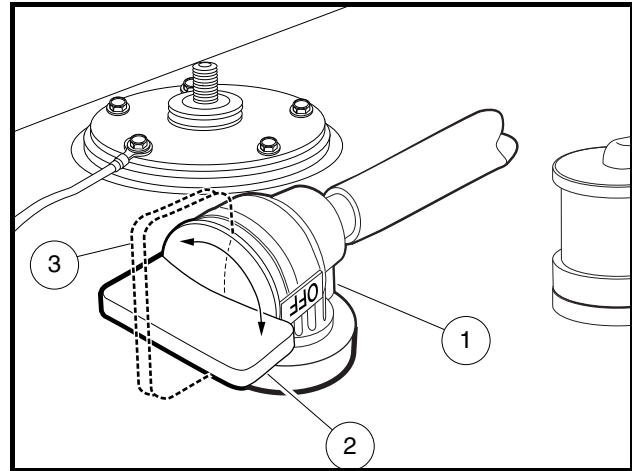
See General Warning, Section 1, Page 1-1.

The fuel shut-off valve is located on top of the fuel tank (**Figure 14-20, Page 14-28** or **Figure 14-21, Page 14-28**). The fuel shut-off valve should always be turned to the closed (OFF) position during vehicle storage, towing or trailering. Unless the engine will be run as part of a procedure, the fuel shut-off valve should also be closed (OFF) before performing maintenance or service procedures.



**Figure 14-20 Fuel Shut-off Valve – 49-State Fuel Tank**

1. Fuel Shut-off Valve 2. Closed (OFF) 3. Open (ON) NOTE: When selecting valve position, ensure that it is fully opened or fully closed.



**Figure 14-21 Fuel Shut-off Valve – California Fuel Tank**

1. Fuel Shut-off Valve 2. Closed (OFF) 3. Open (ON) NOTE: When selecting valve position, ensure that it is fully opened or fully closed.

## CARBON CANISTER (IF EQUIPPED)

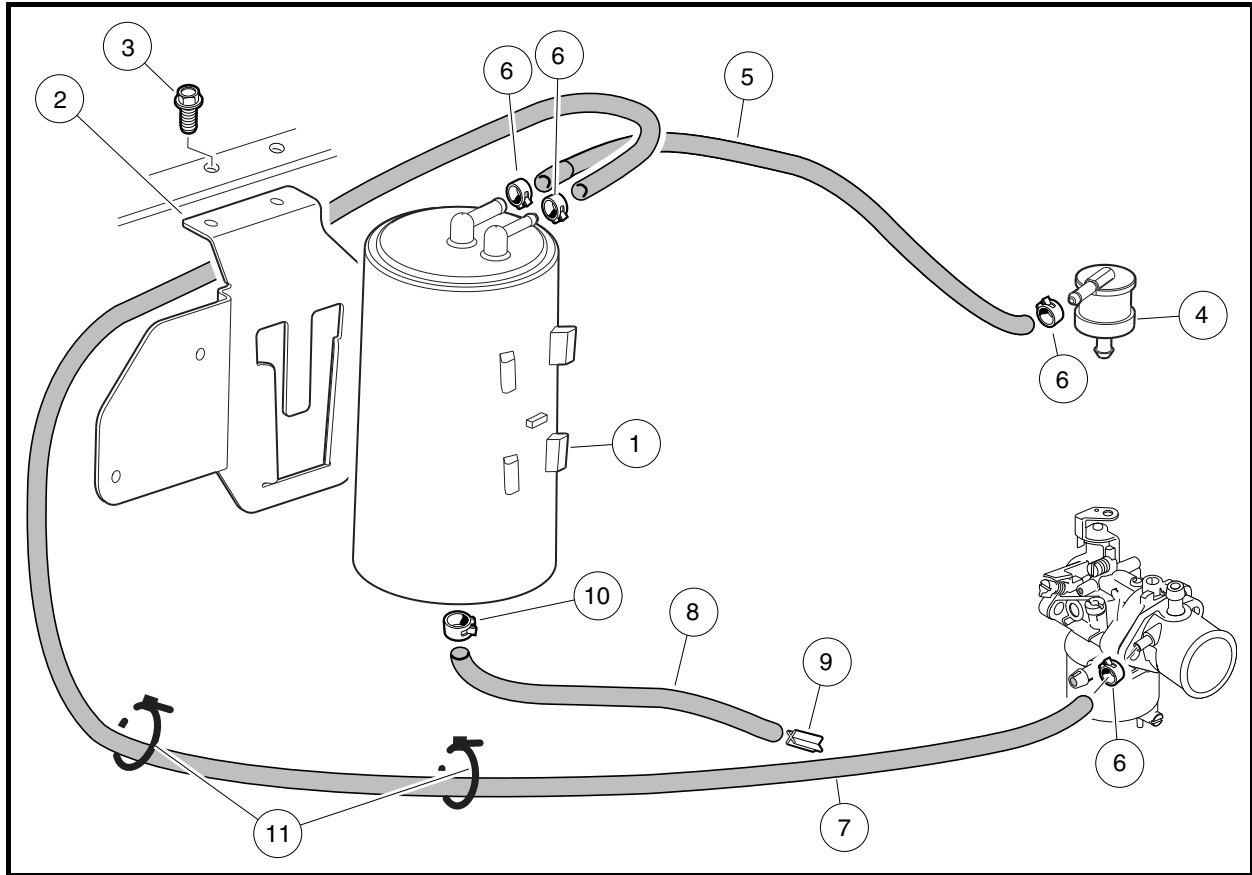
See General Warning, Section 1, Page 1-1.

### **⚠ WARNING**

- If the carbon canister is damaged, replace it. Do not attempt to repair it. See the following canister removal procedure.

## CARBON CANISTER REMOVAL

1. Disable the vehicle. See **Disabling The Vehicle** on page 1-3.
2. Remove seat bottom from vehicle or raise and secure cargo bed.
3. Remove hose clamps (6), securing three hoses (5, 7 and 8) to canister (1), and disconnect hoses (**Figure 14-22, Page 14-29**).
4. Push/pull the canister to force it from its mounting bracket (2).



**Figure 14-22 Carbon Canister, Hoses and Routing**

1. Carbon Canister 2. Molded Vent Tube (Fuel Tank to Canister) 3. Vent Tube (Canister to Engine) 4. Vent Tube (Canister to Atmosphere)

## CARBON CANISTER INSTALLATION

1. Align canister mounting tabs with slots in mounting bracket (2) and push/pull the canister (1) into bracket (**Figure 14-22, Page 14-29**). Force it in until fully seated.
2. Attach hoses (5, 7 and 8) to appropriate locations on carbon canister and secure with hose clamps (6).
3. Install seat bottom or lower cargo bed.



# SECTION 15 – EXHAUST SYSTEM

---

## **⚠ DANGER**

- See General Warning, Section 1, Page 1-1.

## **⚠ WARNING**

- See General Warning, Section 1, Page 1-1.

## MUFFLER

---

### MUFFLER REMOVAL

1. Turn the key switch to OFF and remove the key. Place the Forward/Reverse handle in the NEUTRAL position. Chock the wheels.
2. Disconnect battery and spark plug wire(s). **See Disconnecting The Battery on page 1-3.**
3. Remove the spark plug wire. **See WARNING “To avoid unintentionally starting...” in General Warning, Section 1, Page 1-1.**
4. Remove the muffler clamp (6) from the muffler (1) and clamp bracket (2) (**Figure 15-1, Page 15-2**).
5. Remove the hex-head cap screw (7), lockwasher (8) and flat washer (9) from mounting bracket. Retain the governor cable bracket (13).
6. Remove the hex nuts (10) and lockwashers (11) from the manifold.
7. Remove the muffler (1) from the vehicle.

### MUFFLER INSTALLATION

**NOTE:** Any time the muffler is removed from the vehicle, install a new muffler clamp (6) (CC P/N 1017689) and muffler gasket (12) (**Figure 15-1, Page 15-2**).

1. Loosely attach muffler (1) to muffler bracket (2) with clamp (6) (**Figure 15-1, Page 15-2**).
2. Place a new gasket (12) on the cylinder block exhaust stud bolts.
3. Attach muffler manifold with lockwashers (11) and hex nuts (10) and tighten finger-tight.
4. Loosely attach muffler (1) mounting bracket and governor cable bracket (13) using hex-head cap screw (7), lockwasher (8) and flat washer (9).
5. Tighten manifold hex nuts (10) to 11 ft-lb (14.9 N·m).
6. Tighten hex-head cap screw (7) to 14 ft-lb (18.9 N·m).
7. Tighten muffler clamp (6) to 40 in-lb (4.5 N·m).

**NOTE:** Removing and installing the governor cable bracket may change the RPM setting. **See Engine RPM Adjustment, Section 14, Page 14-10.**

**Muffler Installation, Continued:**

8. Connect battery and spark plug wire(s). **See Connecting The Battery on page 1-3.**
9. With the Forward/Reverse handle in the NEUTRAL position, start the engine and check for exhaust leaks and proper engine operation. **See following DANGER.**
10. Start the engine and check for exhaust leaks and proper engine operation. **See following DANGER**

**⚠ DANGER**

- The engine produces carbon monoxide, which is an odorless, deadly poison. Do not operate the engine in an enclosed area without proper ventilation.

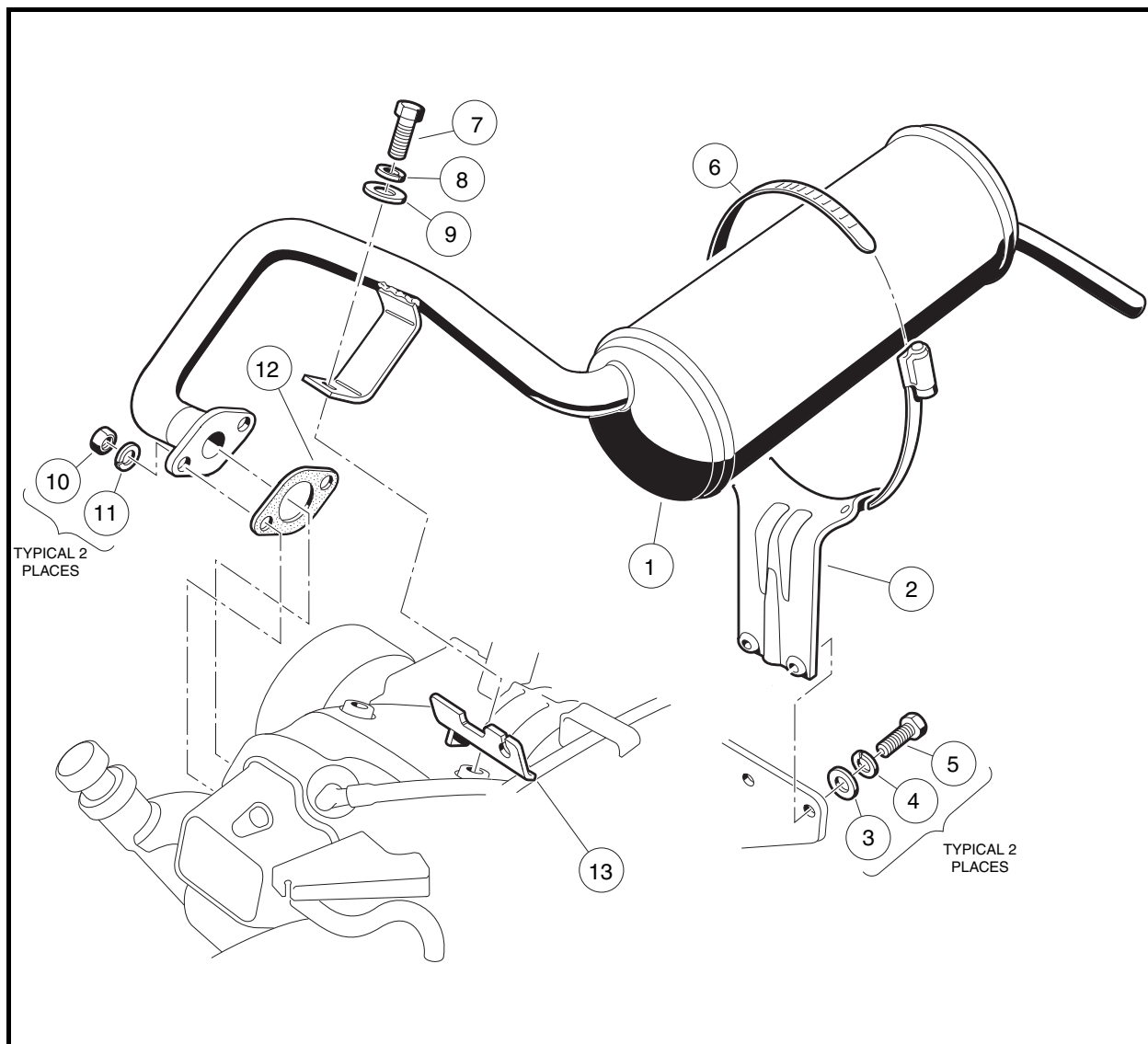


Figure 15-1 Exhaust System – FE400 Engine



# SECTION 16 – MC012C-BS00 UNITIZED TRANSAXLE WITH DIFFERENTIAL LOCK

---

## **⚠ DANGER**

- See General Warning, Section 1, Page 1-1.

## **⚠ WARNING**

- See General Warning, Section 1, Page 1-1.

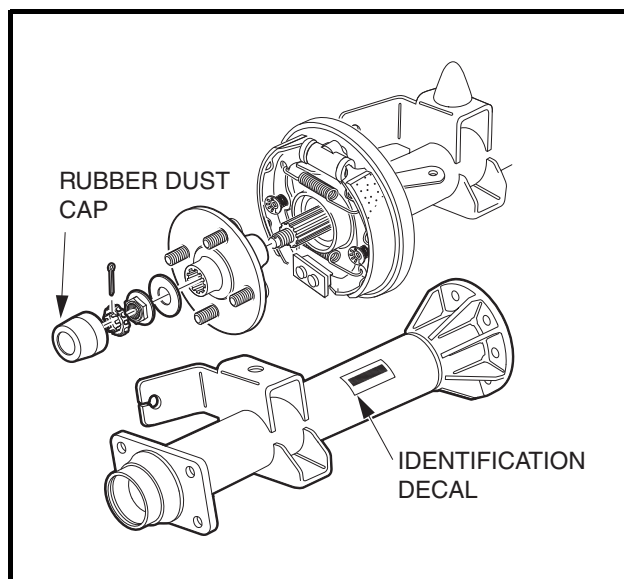
## GENERAL INFORMATION

---

The Turf 272/Carryall 272/XRT 1200 and Carryall 472/XRT 1200 SE vehicles are equipped with a heavy-duty, fully-synchronized unitized transaxle with differential lock. The unitized transaxle utilizes fully-synchronized internal gearing to change vehicle direction. Because the unitized transaxle is used to reverse vehicle direction, the engine, drive clutch, belt and driven clutch rotate in the same direction; therefore, the engine and clutches are not subjected to reversing loads. This reduces maintenance requirements on the engine and clutches. With the unitized transaxle, power is transferred from the engine through the drive clutch, the drive belt, the driven clutch, and then through the unitized transaxle to the wheels.

This transaxle is designed with removable wheel bolt flanges that attach to the ends of the axle shafts using a splined coupling configuration (**Figure 16-1, Page 16-1**). Components for this transaxle are identified in the respective illustrated parts list manual.

This Section contains information on removing and replacing the MC012C-BS00 unitized transaxle. For complete instructions on transaxle disassembly, repair, rebuilding, and reassembly see the Engines and Transaxles Manual (CC P/N 102396501).



**Figure 16-1** MC012C-BS00 Transaxle

## Shifter Lever

A shifter lever, connected to a shifter arm, is used to change the gears to one of three shift positions: FORWARD (F), NEUTRAL (N), or REVERSE (R) (**Figure 16-2, Page 16-2**). Bring the vehicle to a complete stop before changing FORWARD or REVERSE direction.

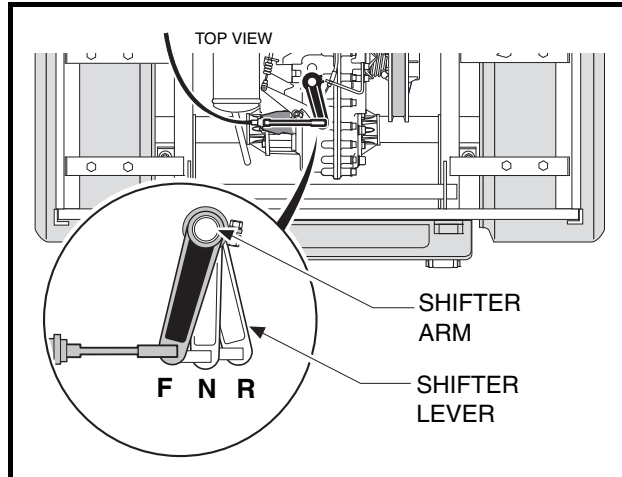


Figure 16-2 Shifter Positions

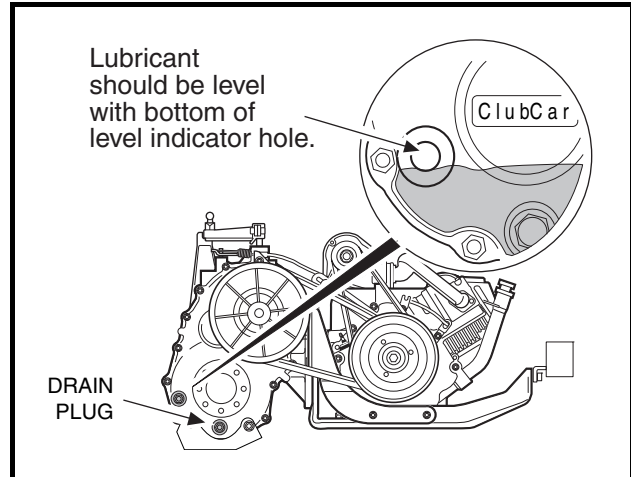


Figure 16-3 Lubricant Level

## LUBRICATION

There are two oil port plugs located on the right (driven clutch) side of the unitized transaxle (**Figure 16-3, Page 16-2**). When the vehicle is on a level surface, use the upper plug as a lubricant level indicator. Lubricant level should be even with the bottom of the hole. The lower plug is used for draining. When draining lubricant, both plugs should be removed to allow the lubricant to drain faster. Be sure the drain plug and gasket are cleaned and installed before filling the transaxle with new lubricant. Use a funnel when filling the transaxle through the lubricant fill hole. Fill with MC012C-BS00 – 29 oz. (.85 liters) 80-90 Wt. API class GL-3 or 80-90 Wt. AGMA class 5 EP gear lubricant. Tighten the plug to 20 ft-lb (27.1 N-m).

## Differential Lock Lever

The differential lock lever is located between the driver and passenger seats (**Figure 16-4, Page 16-2**).



Figure 16-4 Differential Lock Lever

## Neutral Lockout

The neutral lockout feature is not a serviceable component on key-start vehicles. The neutral lockout should remain in the correct position at all times. **See Lockout Cam, Section 11, Page 11-5.**

## Governor System

The governor system regulates vehicle ground speed. It is mounted inside the unitized transaxle and is driven by transaxle gears. If any of the governor linkages are removed in order to service other components, readjustment of the governor linkage is required. **See Governor Cable Installation and Adjustment, Section 14, Page 14-7.**

## Unitized Transaxle Service

The unitized transaxle is extremely durable and should require very little service under normal operating conditions. The only service required is to maintain proper lubricant level. **See Periodic Lubrication Schedule, Section 10, Page 10-3.**

## AXLE SHAFT

---

**See General Warning, Section 1, Page 1-1.**

Removal of the unitized transaxle is not required for servicing or replacing axle shafts, axle bearings, or axle shaft oil seals. If the unitized transaxle is to be removed from the vehicle, then do not remove the wheels, axle shafts, or axle tubes first. Instructions for removing the unitized transaxle from the vehicle begin on page 16-6.

## AXLE SHAFT, BEARING, AND OIL SEAL REMOVAL

1. Chock the front wheels and lift the rear of the vehicle with a floor jack. Then place jack stands under the axle tubes to support the vehicle. **See WARNING “Lift only one end of the vehicle...” in General Warning, Section 1, Page 1-1.**
2. Remove the wheel from the vehicle.
3. Remove the brake drum. If the brake drum was easily removed, proceed to step 5.
4. To remove tight brake drums:
  - 4.1. Locate the bolt heads for the two brake shoe adjusters on the back of each brake cluster assembly.
  - 4.2. Use a torque wrench and a Torx #T-27 driver, or hydraulic brake adjuster (CC P/N 102169401), and gently rotate the adjuster bolt to increase the clearance between the brake shoes and the brake drum. **See Figure 6-2, Section 6, Page 6-7.**
  - 4.3. Rotate the brake drum slightly and remove it from the brake shoe cluster assembly.

**Axle Shaft, Bearing, and Oil Seal Removal, Continued:**

5. To remove the wheel bolt flange on the MC012C transaxle (**Figure 16-5, Page 16-4**):
  - 5.1. Remove rubber boot (26) from large flat washer (23).
  - 5.2. Remove cotter pin (25) from locking nut cap (27).
  - 5.3. Remove the locking nut cap (27) from the flanged nut (24).
  - 5.4. Remove the flanged nut (24) and large flat washer (23) from the axle end.
  - 5.5. Remove the wheel bolt flange (22) from the splined axle end.

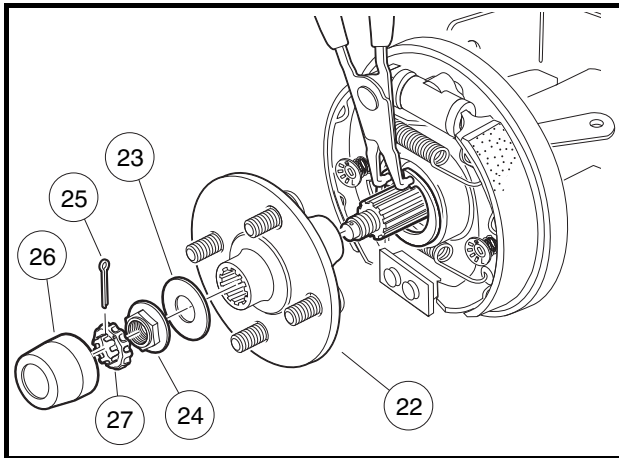


Figure 16-5 Axle Retaining Ring Pliers

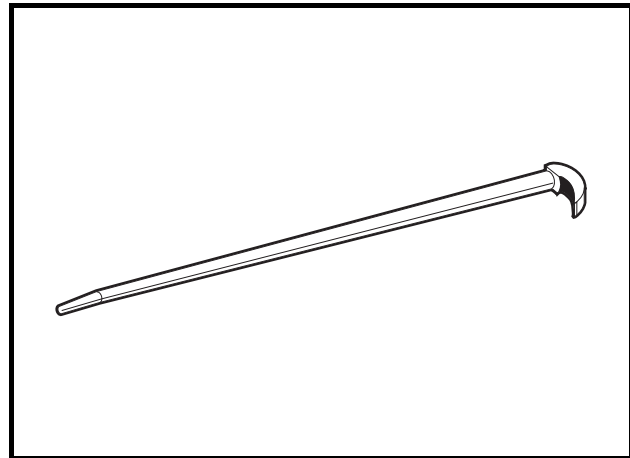


Figure 16-6 Rolling Head Prybar

6. Use a 90° internal snap ring pliers (0.090-inch tip) to remove internal retaining ring from axle tube (**Figure 16-5, Page 16-4**).
7. Carefully pull the axle shaft and bearing straight out of the axle tube.
8. Position a 16-inch (40 cm) rolling head prybar (**Figure 16-6, Page 16-4**) under the inside lip of the seal and pull the oil seal out (**Figure 16-7, Page 16-4**). Discard the oil seal. **See following CAUTION.**

**⚠ CAUTION**

- Do not scar or damage the inside surfaces of the tube when removing the oil seal. A damaged tube might have to be replaced.

9. Inspect the bearing. Remove and replace if damaged or worn (**Figure 16-8, Page 16-6**).

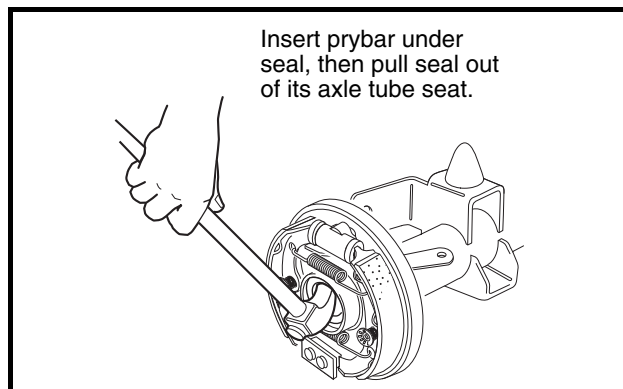


Figure 16-7 Axle Seal

## AXLE SHAFT, BEARING, AND OIL SEAL INSTALLATION

1. Replace the old oil seal with a new seal (89). Make sure the axle tube hub is free of debris.
2. Replace the old bearing with a new bearing (88). Slip the new bearing onto the machined journal, adjacent to the machined seal hub on the end of the axle (**Figure 16-8, Page 16-6**).
3. Clean the axle shaft and spline and carefully slide it through the axle seal, and advance until the splined end meshes with the splined hub inside the gear box assembly, and the bearing slips into the axle tube hub adjacent to the oil seal.
4. Use a 90° internal snap ring pliers and insert the internal retaining ring (87) into the groove in the axle tube hub, adjacent to the outside surface of the bearing. **See following WARNING.**

### **▲ WARNING**

- **Be sure retaining ring is properly seated in its groove. If ring is not properly installed, the axle assembly will separate from the transaxle and damage the axle assembly and other components. Loss of vehicle control could result in severe personal injury or death.**

5. Install the wheel bolt flange (22) on the MC012C transaxle (**Figure 16-5, Page 16-4**). **See following NOTE.**

**NOTE:** Clean splined components before axle installation. Use a small brush and carefully apply a light coat of white lithium NLGI Number 2 grease (Dow Corning® BR2-Plus or equivalent) to splined components before assembly.

- 5.1. Slide wheel bolt flange (22) onto splined end of the axle.
- 5.2. Slide the large flat washer (23) onto the end of the axle and up against the wheel bolt flange. **See following NOTE.**

**NOTE:** It is recommended that a light film of white lithium NLGI Number 2 grease (Dow Corning BR2-Plus or equivalent) be applied to both surfaces of the large washer (23) before the flanged nut (24) is installed and tightened to specification.

- 5.3. Attach the flanged nut (24) and tighten to 150 ft-lb (203 N·m).
- 5.4. Install the locking nut cap (27) onto the flanged nut (24) and position the locking nut cap (27) to provide clear passage for a new cotter pin (25).
- 5.5. Install a new cotter pin (25) through the locking nut cap and axle, bending the split ends of the pin to secure the locking nut cap (27). **See following WARNING.**

### **▲ WARNING**

- **Make sure to install and bend the cotter pin. Failure to bend the cotter pin could result in the separation of the wheel bolt flange from the splined end of the axle. Loss of vehicle control could result, causing severe personal injury.**

- 5.6. Install the rubber boot (26) onto the large washer (23). **See following NOTE.**

**NOTE:** Push the rubber boot onto the washer so that the washer edge fits into the boot-lip groove.

- 5.7. Install the brake drum and wheel.
6. Repeat steps 2 through 5 for the remaining rear axle if necessary.

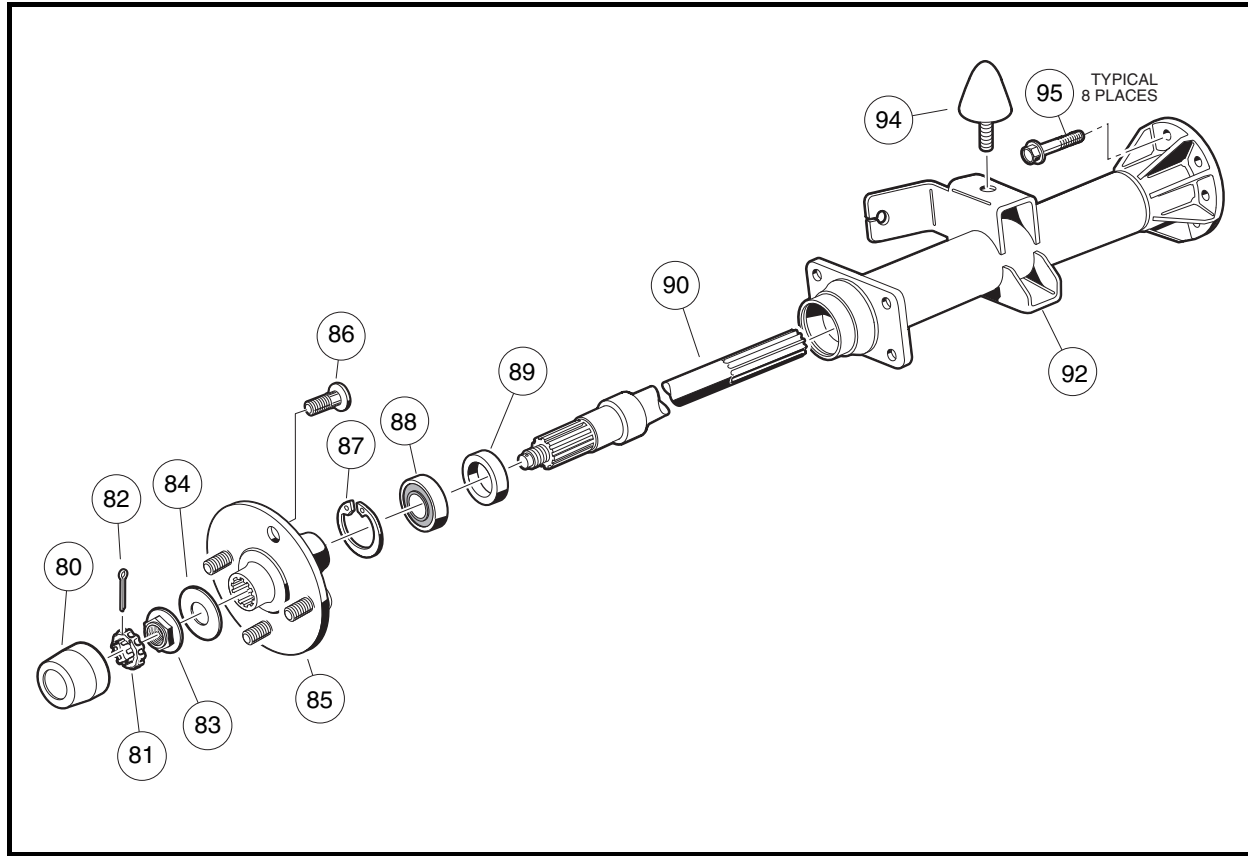


Figure 16-8 Differential Axle and Wheel Hub Assembly

## UNITIZED TRANSAXLE REMOVAL

See General Warning, Section 1, Page 1-1.

### **⚠ WARNING**

- To perform this procedure, the hydraulic system must be opened. As a result, the brakes must be bled after the correct installation of the brake components. Failure to bleed the brakes could result in decreased braking performance due to air being trapped in the hydraulic system. Use only DOT 5 brake fluid. See Bleeding the Hydraulic Brake System, Section 6, Page 6-31.
1. Turn the key switch OFF and remove the key. Place the Forward/Reverse handle in the NEUTRAL position. Chock the front wheels.
  2. Disconnect battery and spark plug wire(s). **See Disconnecting The Battery on page 1-3.**
  3. Close the fuel shut-off valve on fuel tank. **See Fuel Shut-Off Valve, Section 14, Page 14-28.**
  4. Detach all wires, hoses, etc. connecting the powertrain to the vehicle.
    - 4.1. Disconnect the carburetor vent tube from the carburetor (**Figure 16-9, Page 16-7**).

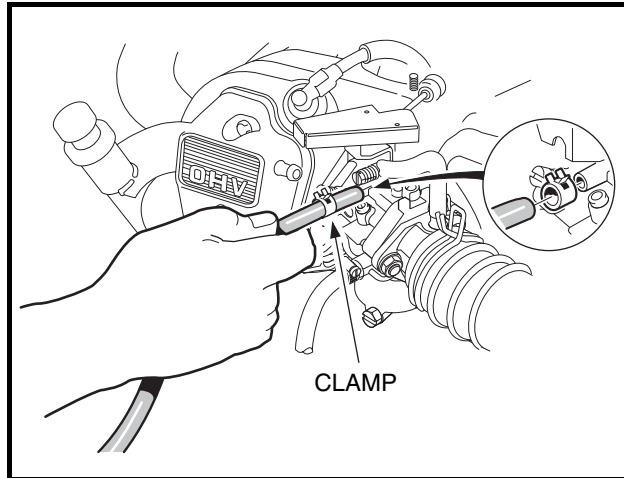


Figure 16-9 Carburetor Vent Tube

- 4.2. Disconnect the air intake hose from the carburetor (Figure 16-10, Page 16-7).
- 4.3. Disconnect impulse line from fuel pump (Figure 16-11, Page 16-7).

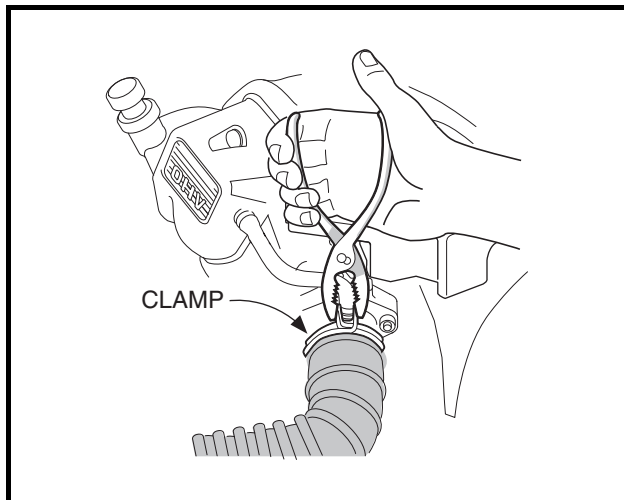


Figure 16-10 Air Intake Hose

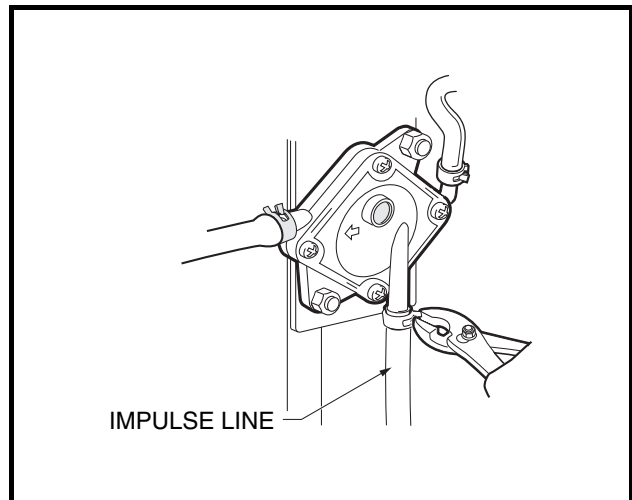
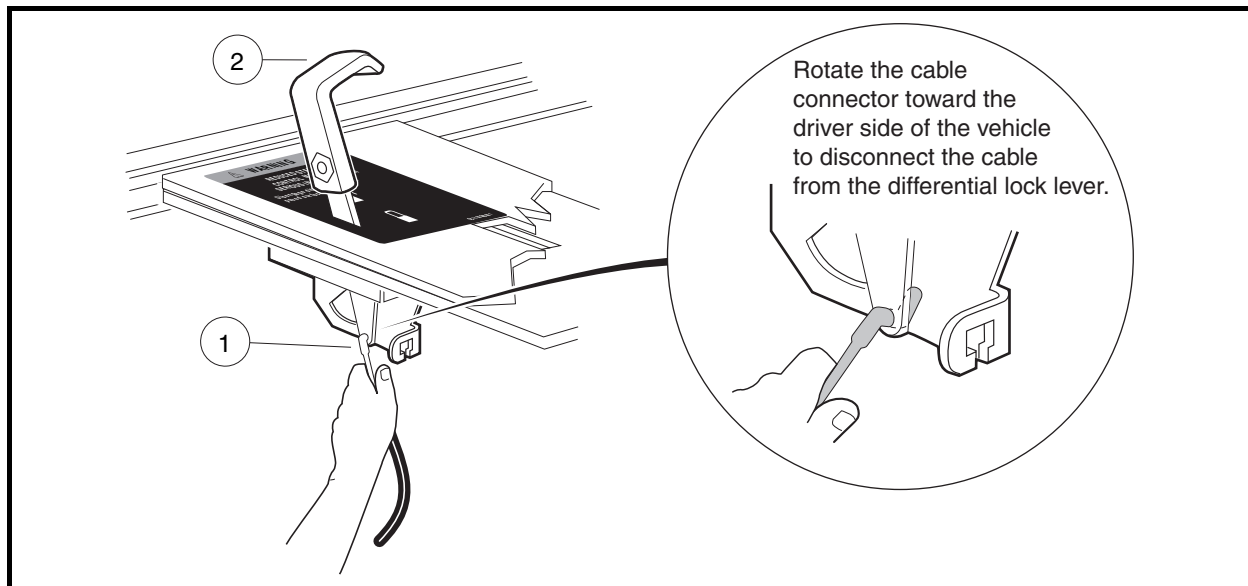
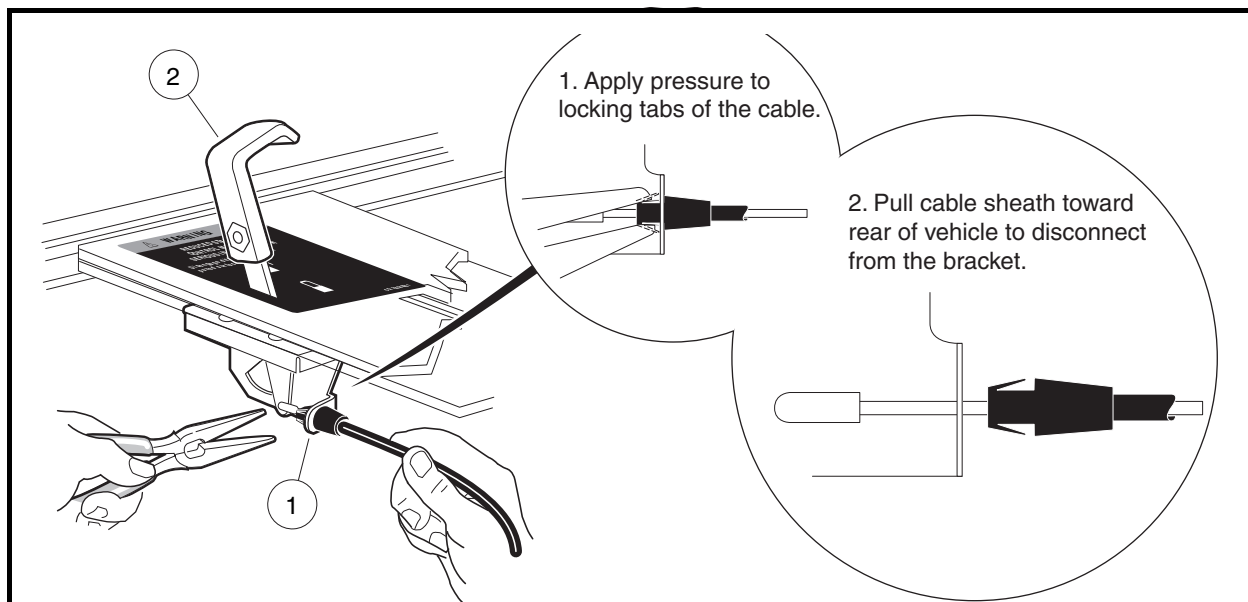


Figure 16-11 Impulse Line

- 4.4. Disconnect the fuel line from the carburetor (Figure 16-14, Page 16-9). Temporarily push the disconnected end of the line onto the impulse line fitting of the fuel pump.
5. Remove the differential lock cable.
  - 5.1. Place differential lock handle in the disengaged direction.
  - 5.2. Use a pair of pliers and apply pressure to the locking tabs of the cable end (1) where it attaches to the differential lock handle mounting bracket (Figure 16-12, Page 16-8). Pull the differential lock cable toward the rear of the vehicle to disconnect the cable from the bracket (Figure 16-12, Page 16-8).
  - 5.3. Rotate the cable connector toward the driver side of the vehicle to disconnect the cable from the differential lock lever (1) (Figure 16-13, Page 16-8).

**Unitized Transaxle Removal, Continued:****Figure 16-12 Differential Lock Cable Bracket****Figure 16-13 Differential Lock Cable Removal**

- 5.4. Remove wire tie (6) securing the cable to the vertical support (**Figure 16-60, Page 16-27**).
- 5.5. Remove the air intake hose from the carburetor.
- 5.6. Remove the cover from the electrical component box.
- 5.7. Loosen the hardware securing the accelerator cable to the box and disconnect the cable from the actuator cam and remove it from the box (**Figure 16-15, Page 16-9**).
- 5.8. Disconnect the engine ground wire from the oil filler tube mounting bracket (**Figure 16-16, Page 16-9**).



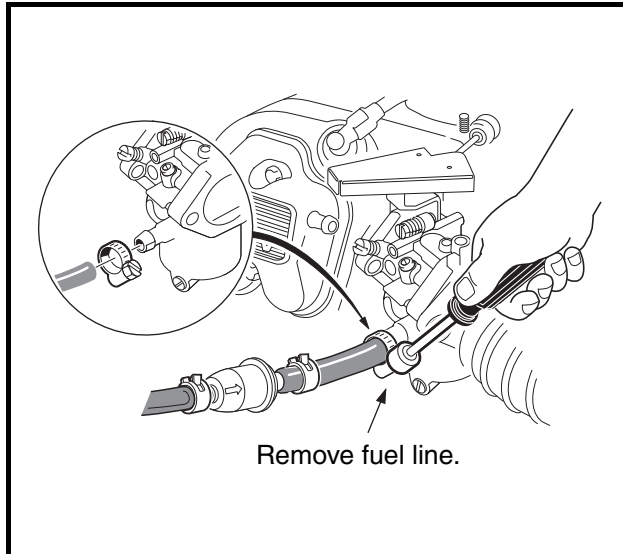


Figure 16-14 Fuel Line

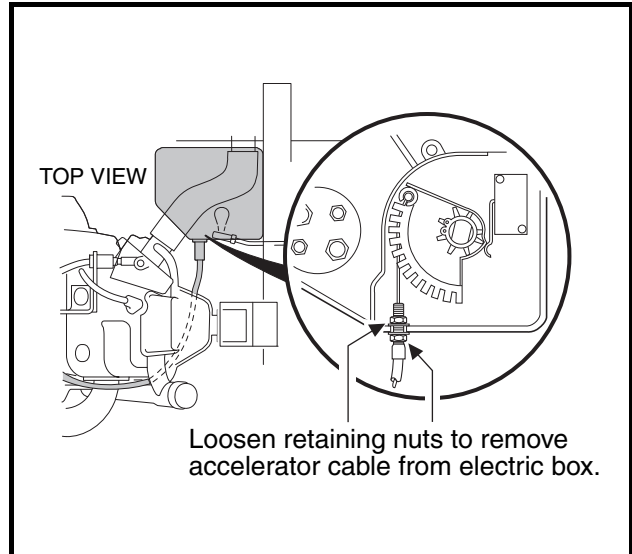


Figure 16-15 Accelerator Cable

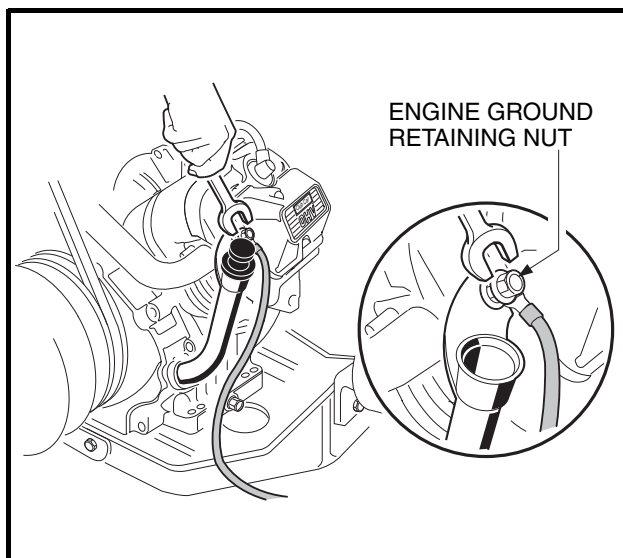


Figure 16-16 Engine Ground Wire

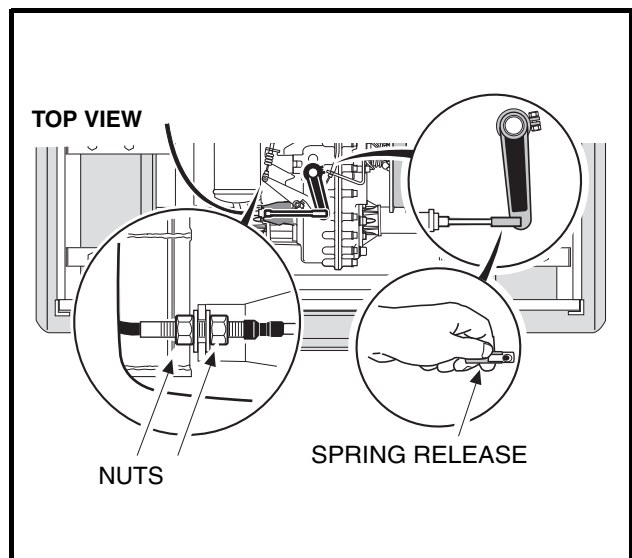


Figure 16-17 Shifter Cable

- 5.9. Loosen nuts securing shifter cable to the mounting bracket and disconnect the shifter cable rod end from the shifter arm on the unitized transaxle. Remove the cable from the cable mounting bracket (**Figure 16-17, Page 16-9**).
- 5.10. Remove screws (2) securing the Forward/Reverse shifter cable bracket (1) to transaxle and remove the shifter bracket (**Figure 16-35, Page 16-15**).
- 5.11. Loosen nut (3) and bolt (7) on transaxle shifter lever (6) and remove lever from shaft.
- 5.12. Remove woodruff key (9) from shifter shaft.
- 5.13. Mark for reference then disconnect the 6-gauge white wire (F2 post), 6-gauge black ground wire (A2 post), and 16-gauge yellow wire (DF post) from starter/generator (**Figure 16-18, Page 16-10**).
- 5.14. Disconnect the engine oil level sensor wire (18-gauge yellow) at the bullet connector just to the rear of the starter/generator (**Figure 16-19, Page 16-10**).

## Unitized Transaxle Removal, Continued:

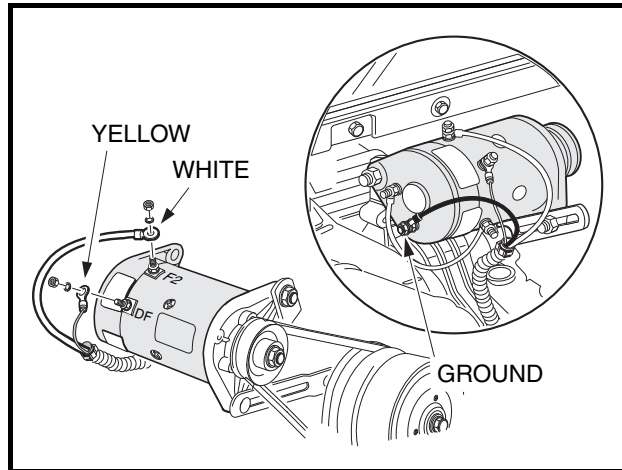


Figure 16-18 Generator Wires

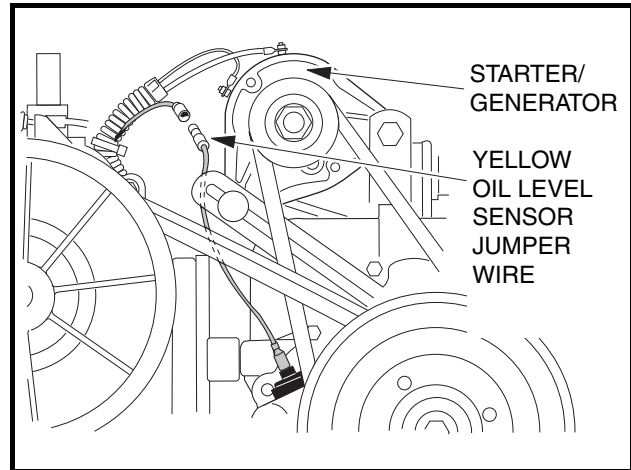


Figure 16-19 Oil Level Sensor Jumper Wire

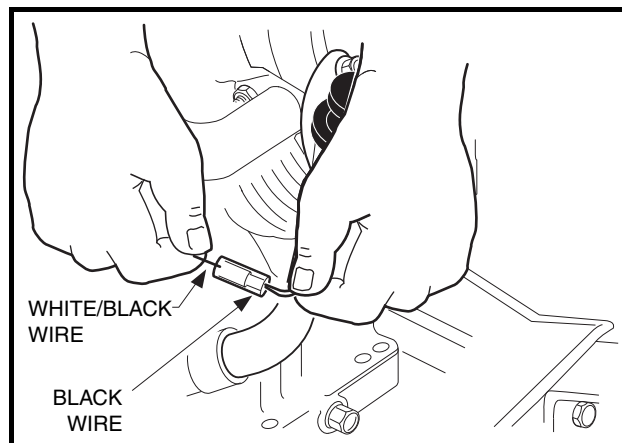


Figure 16-20 Engine Kill Switch Wire

- 5.15. Disconnect the engine kill switch wire (18-gauge white/black) from the bullet connector at the lower right front of the engine (**Figure 16-20, Page 16-10**).
- 5.16. Cut away the wire ties securing the kill switch wire at the lower right front of the engine (below the exhaust header), the wire harness at the governor cable bracket, and the wire harness to the plate beneath the muffler.
6. Remove the lower shock mounting hardware from both rear shocks (**Figure 16-24, Page 16-12**).
7. Disconnect the brake hoses and park brake cables.
  - 7.1. Remove the park brake cable clip (1), hair spring cotter pin (2) and clevis pin (3) (**Figure 16-22, Page 16-11**).
  - 7.2. Remove the cable from the cable support bracket (**Figure 16-22, Page 16-11**).
  - 7.3. Remove the upper shock mounting hardware from the rear shock absorber and remove the shock absorber.
  - 7.4. Use a 3/8 inch flare nut wrench and remove the brake hose from the rear brake cluster. To avoid spilling brake fluid, lift the hose above the brake cluster assembly (**Figure 16-23, Page 16-11**).
  - 7.5. To ensure that no dirt or trash enters the hydraulic braking system, place the hose fitting in a plastic bag and secure to the vehicle frame (**Figure 16-21, Page 16-11**).
  - 7.6. Repeat steps 7.1 through 7.5 for the opposite side of the vehicle.

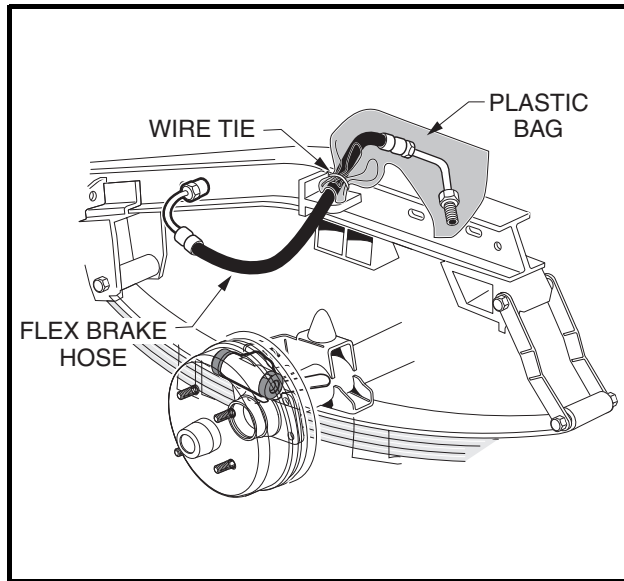


Figure 16-21 Cover Brake Hose Fitting

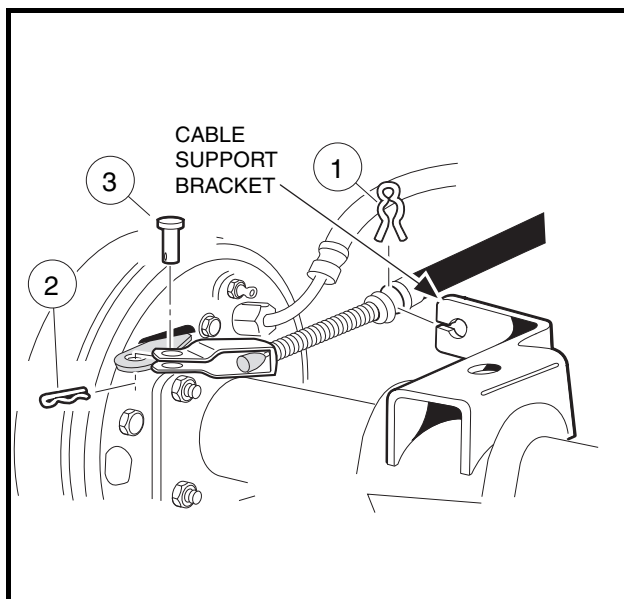


Figure 16-22 Park Brake Cable

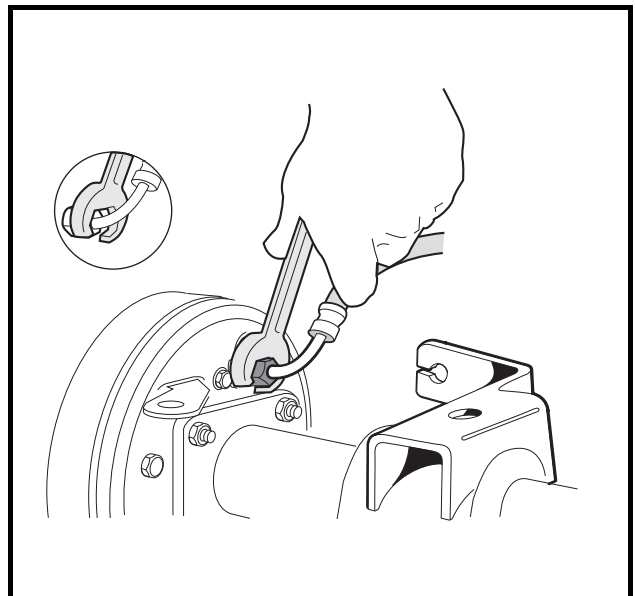
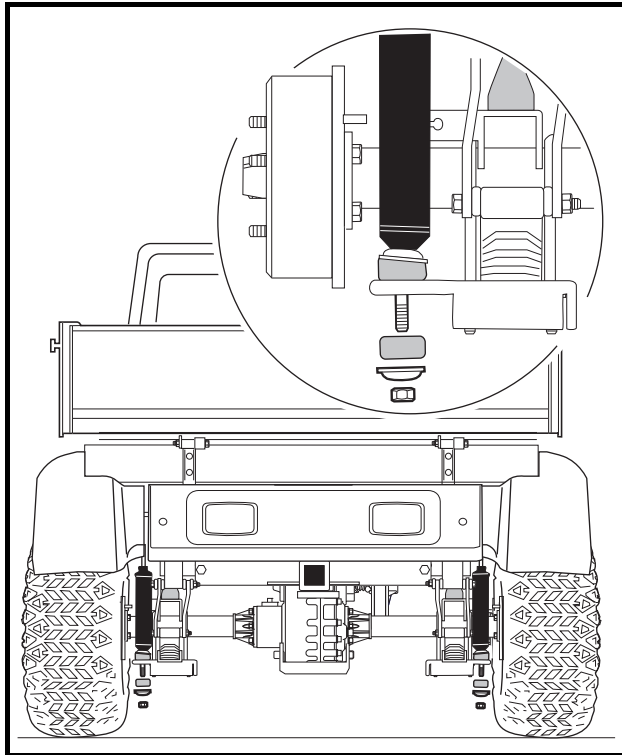


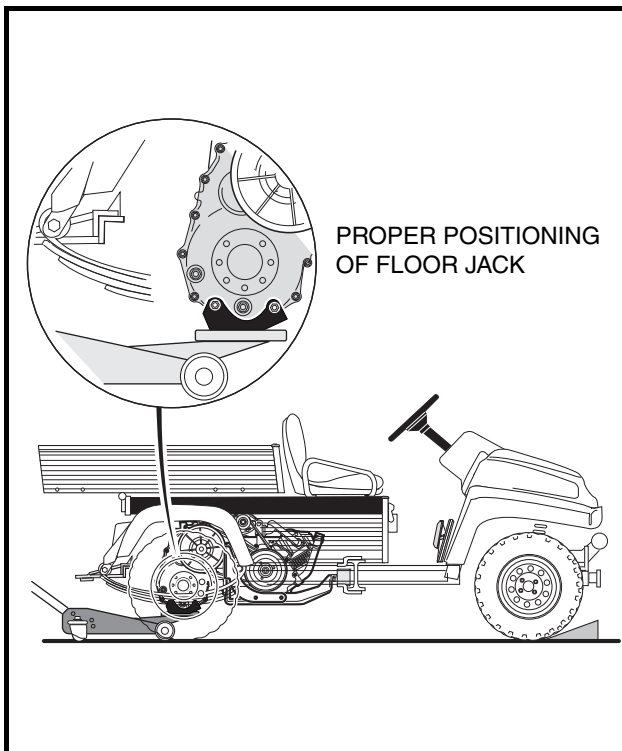
Figure 16-23 Brake Hose

8. Use a hydraulic jack under the transaxle (**Figure 16-25, Page 16-12**) and raise the vehicle. Place jack stands, set at approximately 17-1/2 inches (44.5 cm) in height, under the frame (**Figure 16-26, Page 16-12**).
9. Lower the hydraulic jack, allowing the vehicle I-beam frame to rest on the jack stands but allow the jack to remain under, and in contact with the transaxle case guard (**Figure 16-26, Page 16-12**).
10. Remove the bolts securing the leaf springs to their front mounts (**Figure 16-27, Page 16-13**).
11. Remove the bolts that secure the leaf springs to the shackles (**Figure 16-28, Page 16-13**).
12. With the hydraulic jack, slowly lower the transaxle and powertrain until both of the rear tires are resting on the floor.

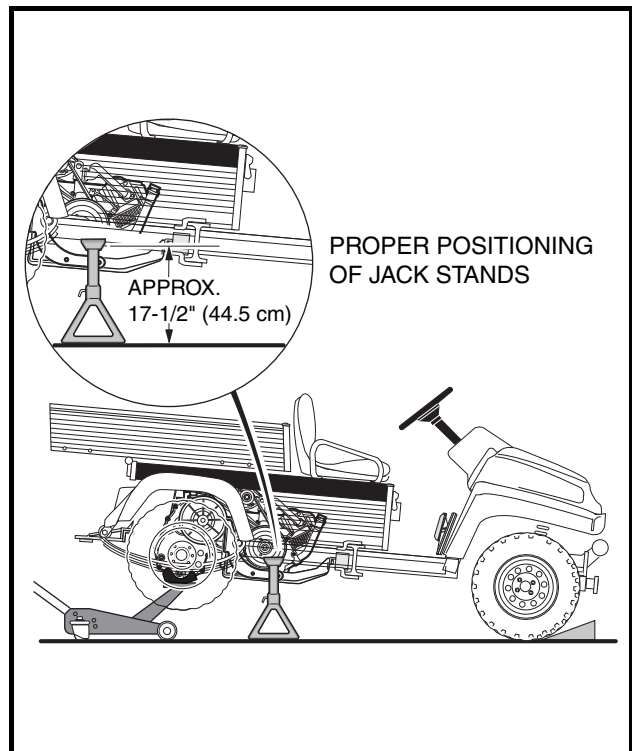
**Unitized Transaxle Removal, Continued:**



**Figure 16-24 Shock Absorbers**



**Figure 16-25 Raise Vehicle**



**Figure 16-26 Position Jack Stands**

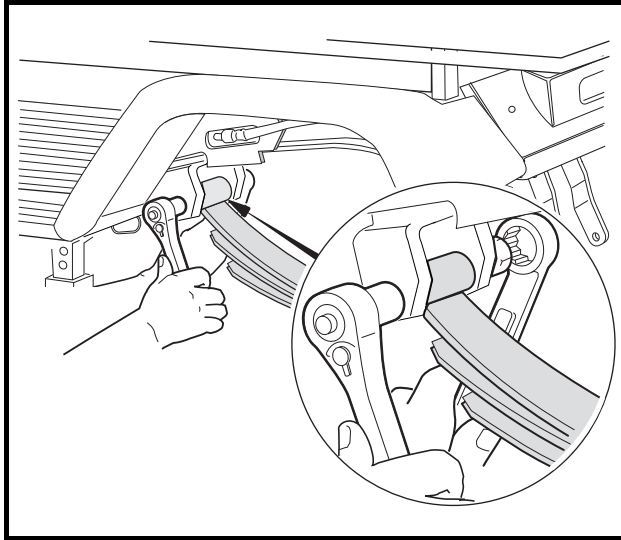


Figure 16-27 Spring Retainer Bolts

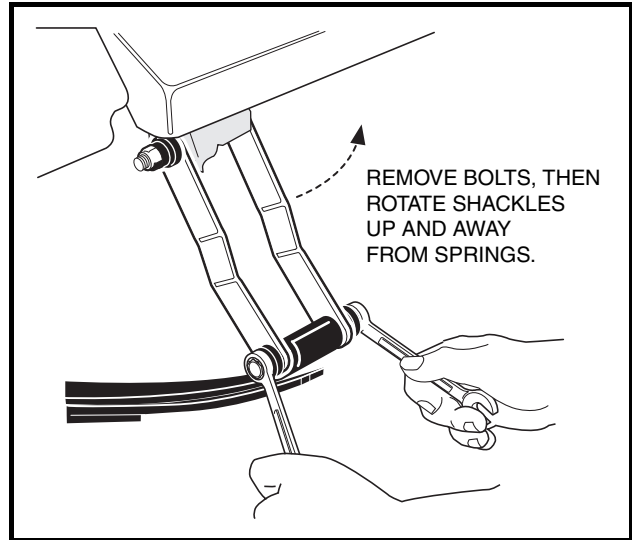


Figure 16-28 Rear Shackles

13. Carefully lift the snubber out of the snubber bracket in the vehicle frame and lower it to the floor (**Figure 16-29, Page 16-13**). The powertrain should be completely disconnected from the vehicle and resting on the floor.
14. Grasp the ends of the leaf springs at the rear of the powertrain and roll the powertrain out from under the vehicle (**Figure 16-30, Page 16-13**).
15. Place blocks under the engine pan so they will completely support the engine and keep it level to the floor (**Figure 16-31, Page 16-14**). See following **NOTE**.

**NOTE:** Place the blocks so they will support the engine when the transaxle is detached and moved away from the engine.

16. Remove the drive belt.
  - 16.1. Grasp belt midway between drive and driven clutch and pull up on belt to force the driven clutch sheaves apart. Roll the belt counterclockwise while pulling it off driven clutch (**Figure 16-32, Page 16-14**).

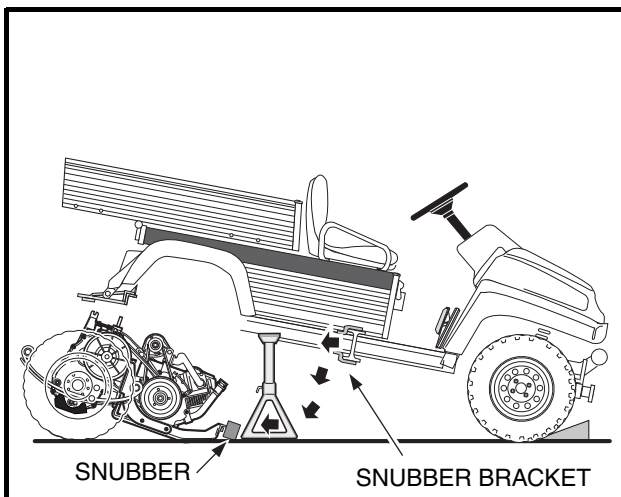


Figure 16-29 Snubber

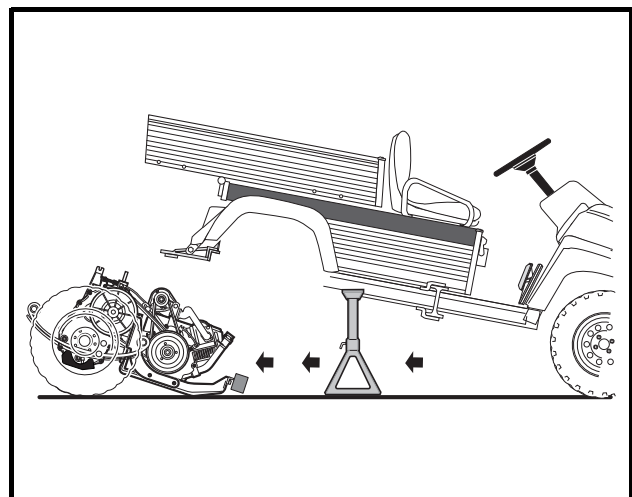


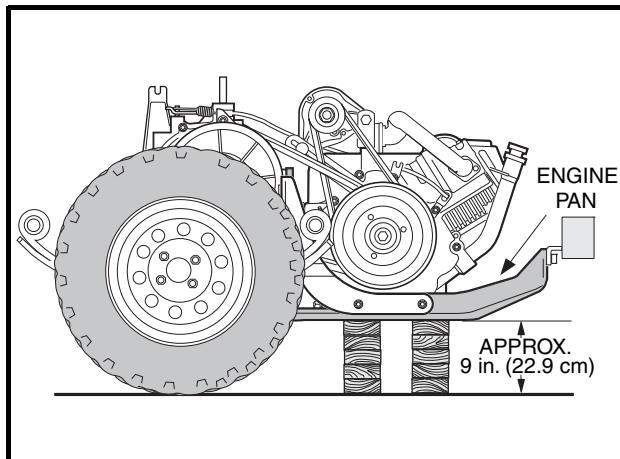
Figure 16-30 Remove Powertrain

**Unitized Transaxle Removal, Continued:**

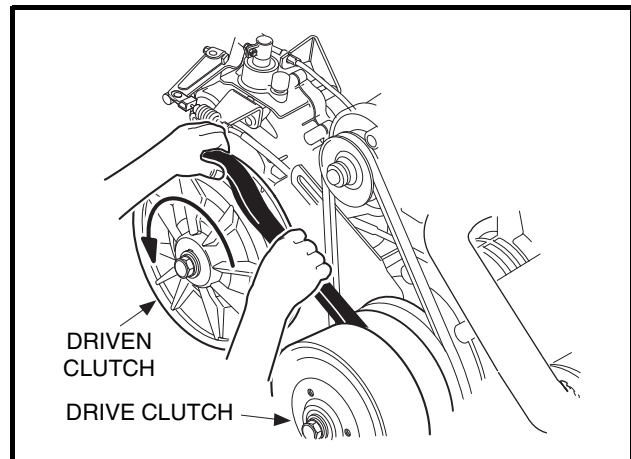
17. Remove the driven clutch retaining bolt and remove the driven clutch from the unitized transaxle (**Figure 16-33, Page 16-14**).
18. Loosen, but do not remove, the governor arm retaining bolt. Remove the governor arm from the shaft (**Figure 16-34, Page 16-14**).
19. Remove screws securing the governor cable bracket to transaxle.
20. Remove screws securing the accelerator cable bracket to transaxle (**Figure 16-38, Page 16-16**). See following **NOTE**.

**NOTE:** The governor cable and the accelerator cable should remain attached to the governor arm.

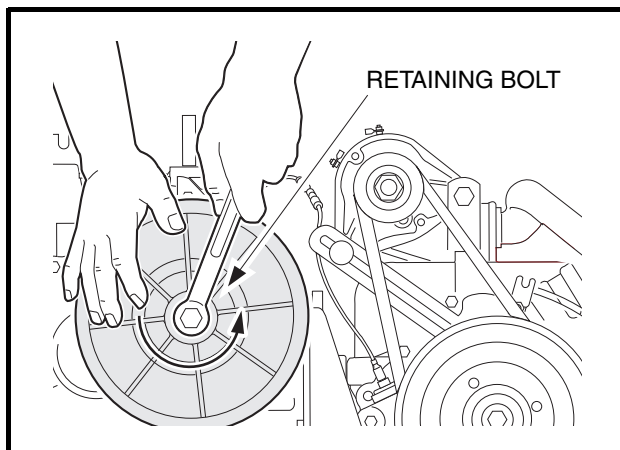
21. Remove the two bolts that secure the differential lock cable bracket to the transaxle housing and unhook the cable spring from the differential lock arm (**Figure 16-36, Page 16-16**).
22. Remove the six bolts mounting the unitized transaxle to the engine.
  - 22.1. Remove four transaxle mounting bolts (one at each corner of the transaxle mounting plate) as shown (**Figure 16-37, Page 16-16**).
  - 22.2. Remove two middle transaxle mounting nuts as shown (**Figure 16-37, Page 16-16**).
23. Remove leaf springs, wheels and brake assemblies from transaxle.



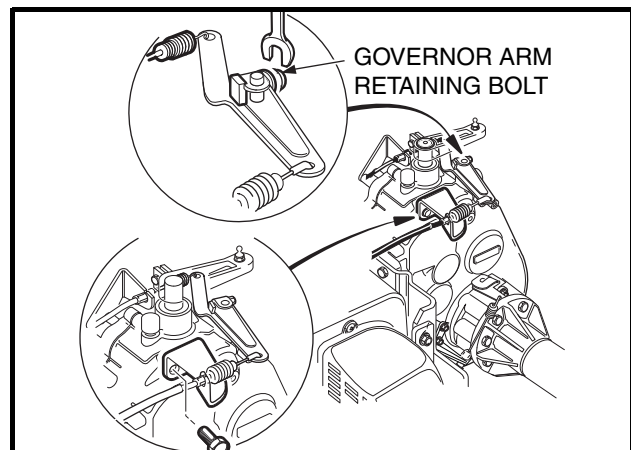
**Figure 16-31** Position Powertrain



**Figure 16-32** Remove Drive Belt



**Figure 16-33** Driven Clutch



**Figure 16-34** Governor Arm and Cable Bracket

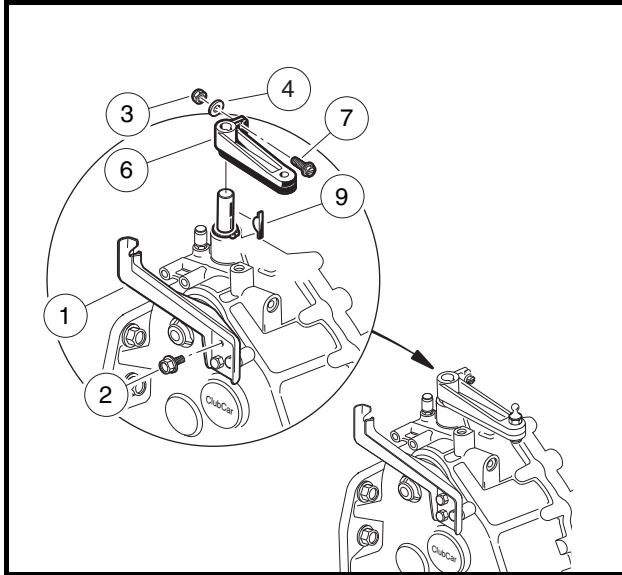


Figure 16-35 Forward/Reverse Shifter Bracket

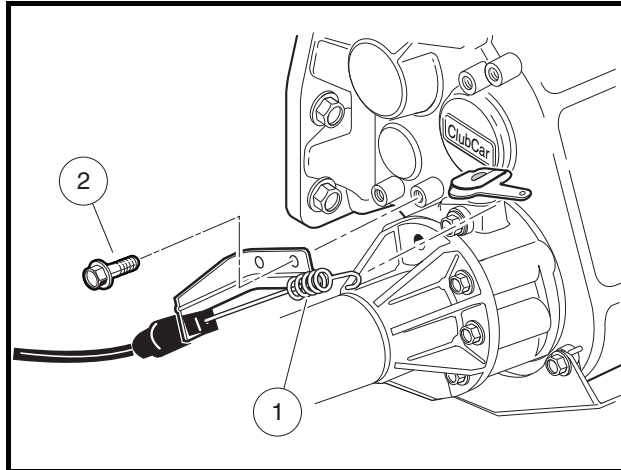
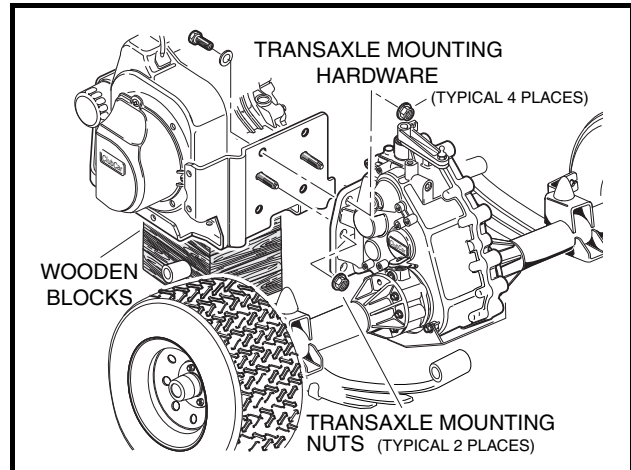
## UNITIZED TRANSAXLE INSTALLATION

See General Warning, Section 1, Page 1-1.

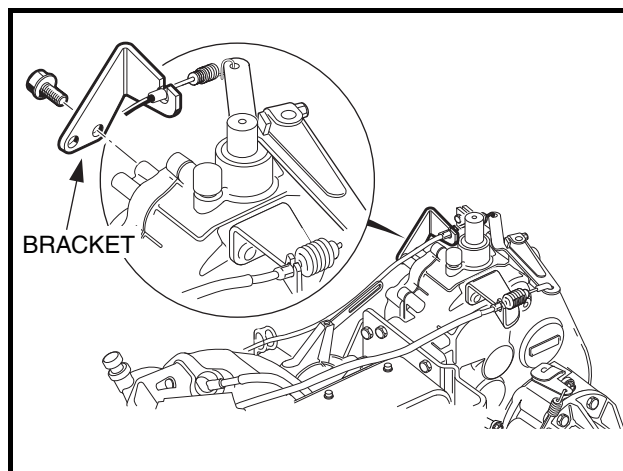
1. Install the wheels. See General Information, Section 8, Page 8-1.
2. Install the leaf springs. See Multi-Leaf Spring Installation, Section 9, Page 9-3.
3. Position the transaxle mounting plate on the two mounting studs at the rear of the engine, and install the two mounting nuts (Figure 16-37, Page 16-16).
4. Install the remaining four mounting bolts and four nuts (one bolt and nut at each corner of the mounting plate) (Figure 16-37, Page 16-16).
5. Tighten the four corner nuts (with bolts) to 23 ft-lb (31 N·m). Tighten the two center nuts (on the studs) to 17 ft-lb (23.1 N·m).

**Unitized Transaxle Installation, Continued:**

6. Install the differential lock cable and bracket.
  - 6.1. Connect the differential lock cable spring (1) to the differential lock arm on the housing (**Figure 16-36, Page 16-16**).
  - 6.2. Install two bolts (2) to secure cable bracket to the transaxle case and tighten to 134 in-lb (15.1 N·m).

**Figure 16-36 Differential Lock Bracket Installation****Figure 16-37 Transaxle Mounting**

7. Install the accelerator cable bracket on transaxle case and tighten screws to 134 in-lb (15.1 N·m) (**Figure 16-38, Page 16-16**).
8. Install the governor cable bracket on transaxle case and tighten the mounting screws to 134 in-lb (15.1 N·m) (**Figure 16-39, Page 16-17**).
9. Loosely install governor lever arm on governor shaft (**Figure 16-40, Page 16-17**). Turn the governor arm shaft counterclockwise until it stops. Pull the governor lever arm rearward until the carburetor throttle is in the “wide open throttle” (WOT) position.

**Figure 16-38 Accelerator Cable Bracket**

10. Hold the arm and shaft in the fully counterclockwise position and tighten the governor arm lever nut to 35 in-lb (4.0 N·m) (**Figure 16-40, Page 16-17**).

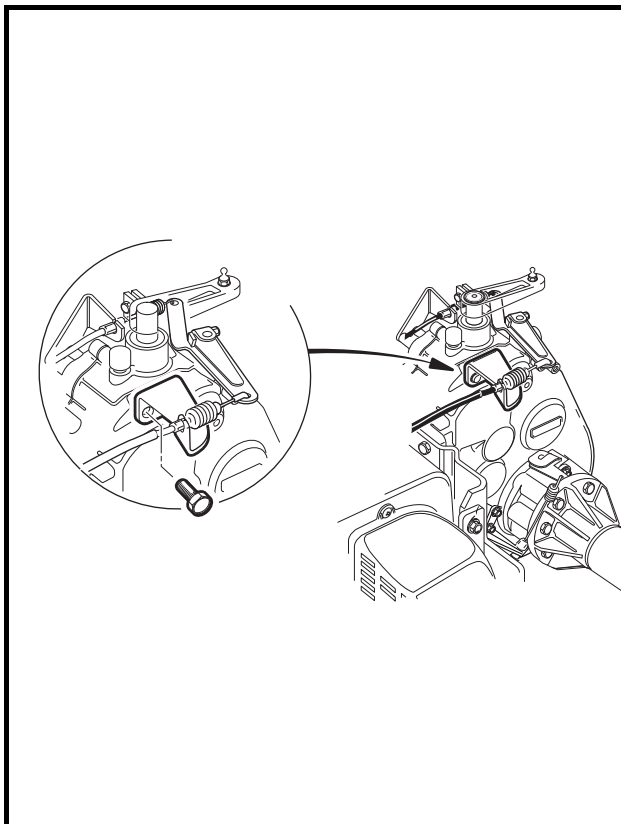


11. Install the key onto the input shaft (**Figure 16-44, Page 16-19**).
12. Position the driven clutch on the transaxle input shaft and install the washer (yellow side facing out) and mounting bolt and tighten to 14 ft-lb (19.0 N·m) (**Figure 16-44, Page 16-19**).
13. Install the drive belt. **See Drive Belt Installation, Section 17, Page 17-3.**
14. Remove the blocks from under the engine and roll the powertrain into position under the vehicle. Lift the front of the powertrain and place the snubber into the snubber bracket in the vehicle frame (**Figure 16-45, Page 16-19**).
15. Position the powertrain, using the floor jack, to align the leaf springs in the front spring mounts and install the grade eight bolts and locknuts and tighten to 15 ft-lb (20.3 N·m) (**Figure 16-42, Page 16-18**). **See following CAUTION.**

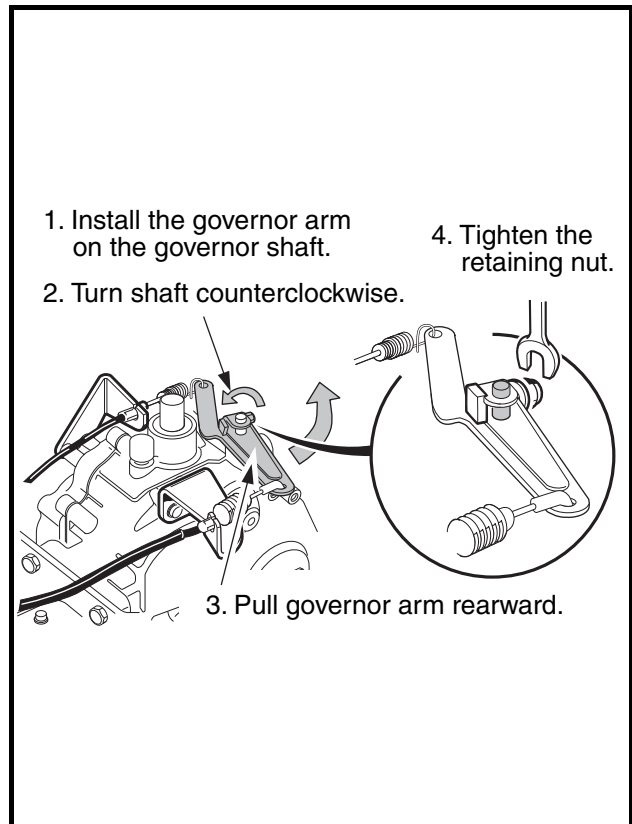
### **⚠ CAUTION**

- Use only grade eight bolts for the front leaf spring supports.

16. Adjust the powertrain height, using the floor jack, to align the leaf springs for mounting in the shackles and install the mounting bolts and locknuts and tighten to 15 ft-lb (20.3 N·m) (**Figure 16-43, Page 16-18**).
17. Raise the vehicle with the floor jack and remove the jack stands. Gently lower the vehicle and finish tightening the lug nuts, using a crisscross pattern, to 55 ft-lb (74.6 N·m) for steel wheels or 65 ft-lb (88 N·m) for alloy mag wheels.
18. Position shocks in the shock mounts and install cushions, mounting washers and nuts and tighten until cushions expand to be the same diameter as the mounting washers (**Figure 16-41, Page 16-18**).

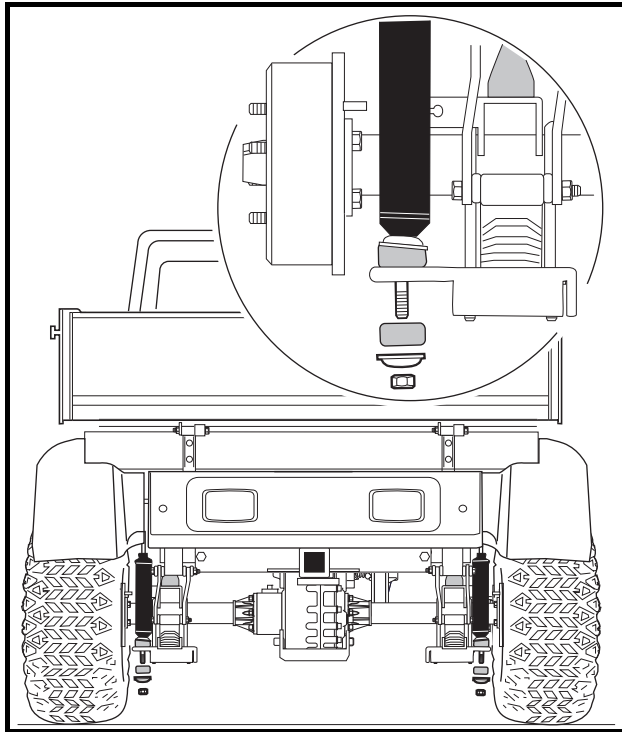


**Figure 16-39 Governor Cable Bracket**

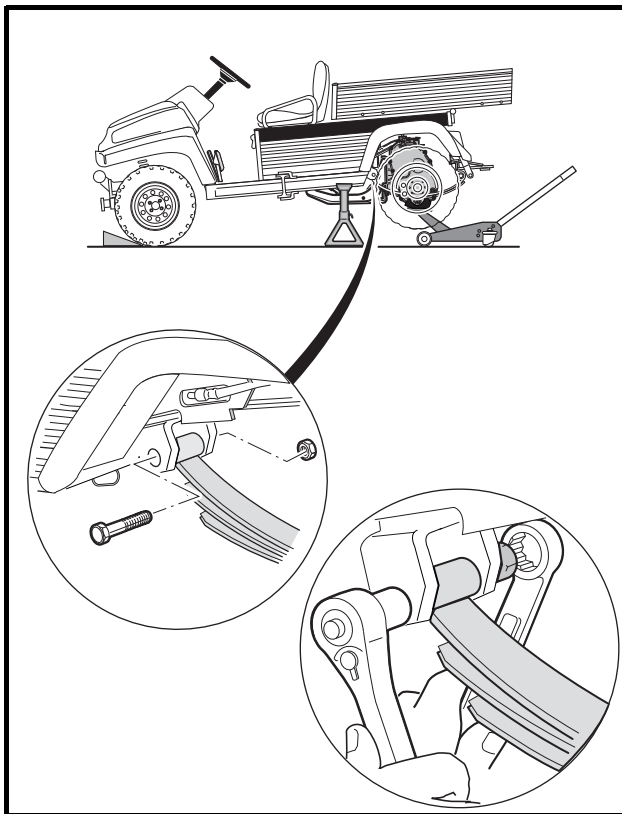


**Figure 16-40 Governor Arm**

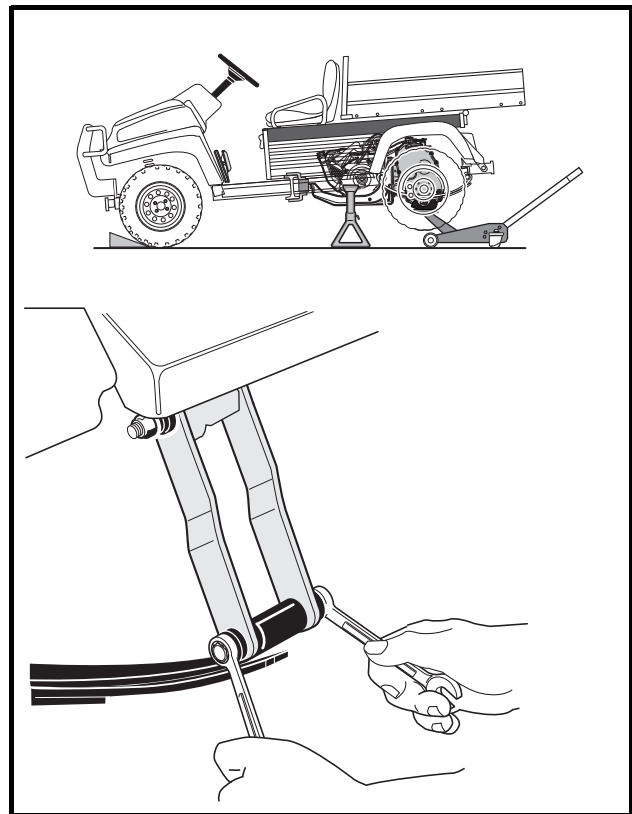
**Unitized Transaxle Installation, Continued:**



**Figure 16-41 Shock Absorber**



**Figure 16-42 Leaf Springs**



**Figure 16-43 Leaf Springs and Shackles**

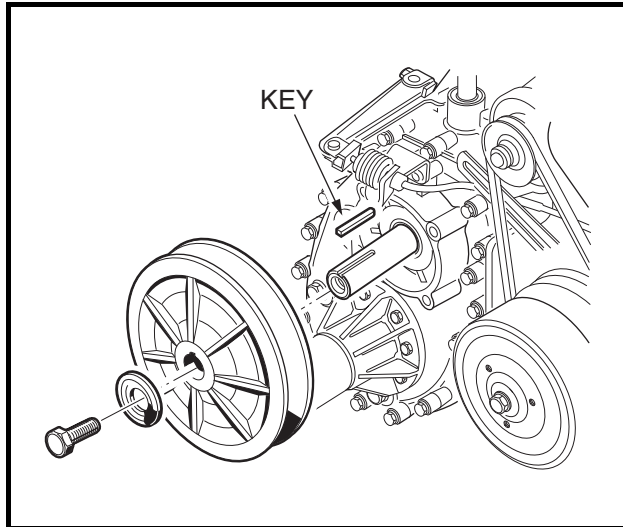


Figure 16-44 Driven Clutch

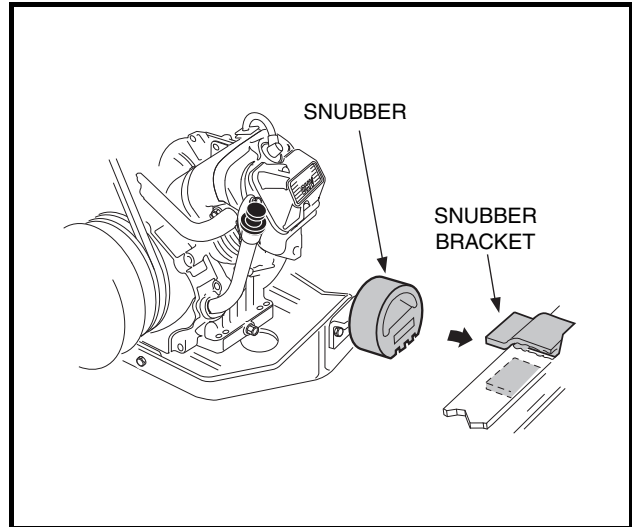


Figure 16-45 Snubber

19. Connect the park brake cables. **See Park Brake Cable Installation, Section 6, Page 6-34.**
20. Use a 3/8-inch flare nut wrench to connect the brake hoses to the left and right rear brake clusters and bleed the air from the brake lines. **See Bleeding the Hydraulic Brake System, Section 6, Page 6-31.**
21. Check the brake system to ensure that there are no leaks and that proper brake operation has been restored. **See following WARNING.**

### **▲ WARNING**

- **The brakes must be bled after the correct installation of the brake components. Failure to bleed the brakes could result in decreased braking performance due to air being trapped in the hydraulic system. See Bleeding the Hydraulic Brake System, Section 6, Page 6-31.**

22. Connect the engine kill switch wire (18-gauge white/black stripe) to the bullet connector at the lower right front of the engine (**Figure 16-46, Page 16-19**).
23. Install three wire ties to secure the engine kill wire and accelerator cable.
24. Connect the oil level sensor wire (18-gauge yellow) to the jumper wire (**Figure 16-47, Page 16-20**).

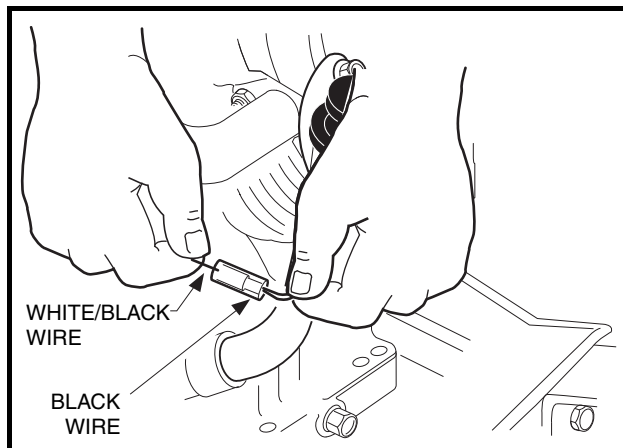


Figure 16-46 Ignition Kill Wire

**Unitized Transaxle Installation, Continued:**

25. Connect the 6-gauge white wire to the F2 post and the 6-gauge black ground wire to the A2 post of the starter generator and tighten to 48 in-lb (5.4 N·m). Connect the 16-gauge yellow wire to the DF post and tighten to 30 in-lb (3.4 N·m) (**Figure 16-48, Page 16-20**).
26. Connect the Forward/Reverse shifter and bracket to the transaxle.
  - 26.1. Install the three screws (2) securing the Forward/Reverse shifter cable bracket (1) to transaxle and tighten them to 135 in-lb (15.3 N·m) (**Figure 16-35, Page 16-15**).
  - 26.2. Place the woodruff key (9) on the shifter shaft.
  - 26.3. Place the shifter lever (6) (aligned with the woodruff key) onto the Forward/Reverse shaft (15).
  - 26.4. Install the nut (3), washer (4), and bolt (7) on the Forward/Reverse shifter lever and tighten to 23 in-lb (2.6 N·m).
  - 26.5. Position the shifter cable in the shifter cable mounting bracket on the transaxle and tighten the mounting nuts to 22 ft-lb (29.8 N·m). Connect shifter cable rod end to the shifter arm (**Figure 16-49, Page 16-20**).
27. Attach the ground wire to the mounting screw on the oil filler tube mounting bracket and tighten to 50 in-lb (5.7 N·m) (**Figure 16-50, Page 16-20**).

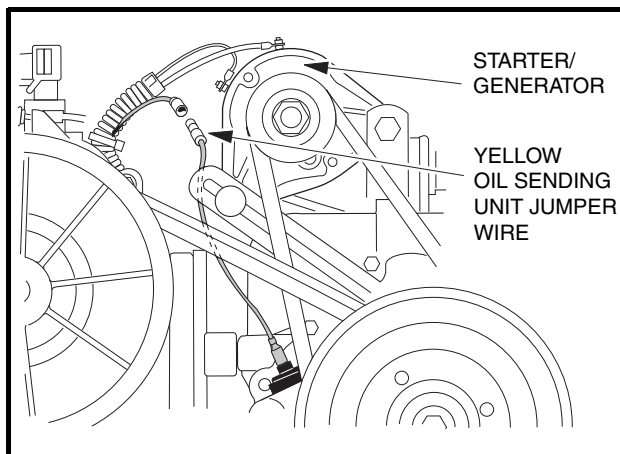


Figure 16-47 Oil Level Sensor Jumper Wire

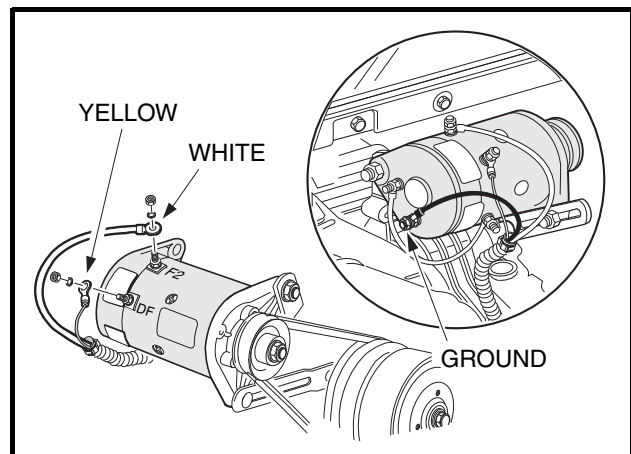


Figure 16-48 Starter/Generator

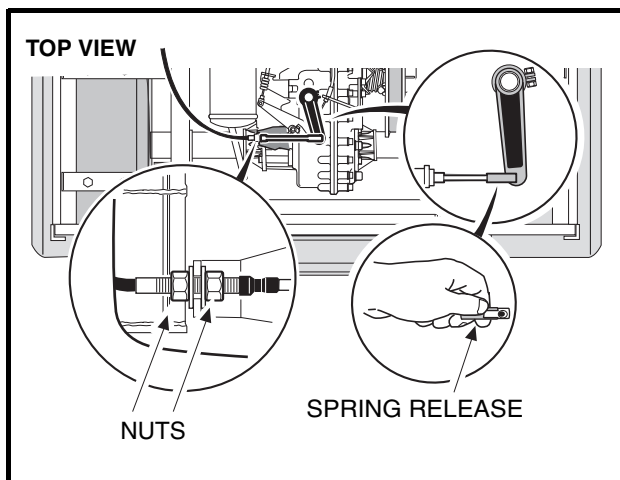


Figure 16-49 Connect Shifter Cable

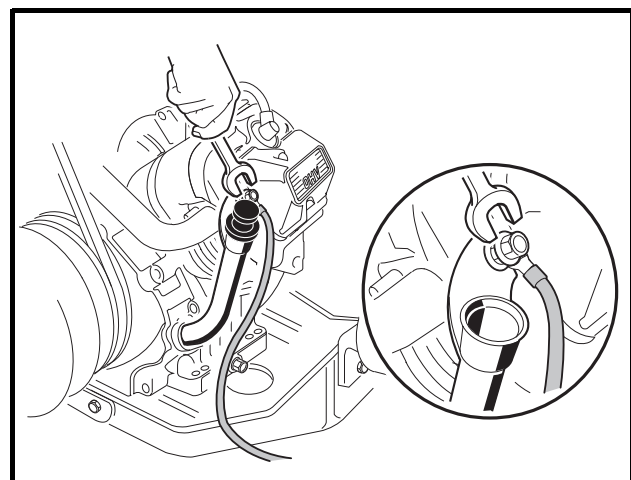


Figure 16-50 Engine Ground

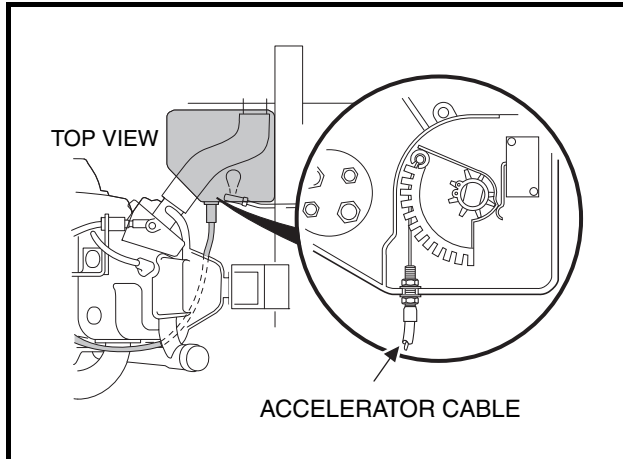


Figure 16-51 Connect Cable to Cam

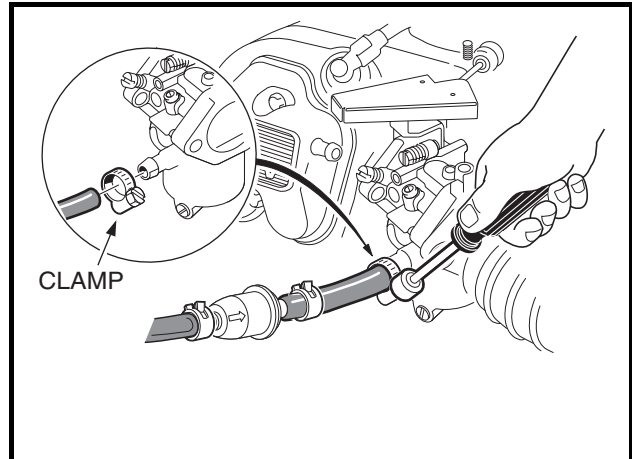


Figure 16-52 Connect Fuel Line

28. Connect accelerator cable to actuator cam in the electrical box. Position the accelerator cable in mounting slot in the wall of the electrical box and tighten mounting nuts to 18 in-lb (2.0 N·m) (**Figure 16-51, Page 16-21**). Install electrical box cover and tighten mounting screw to 18 in-lb (2.0 N·m).
29. Pull fuel line from impulse line fitting of the fuel pump and connect it to the carburetor and secure with a hose clamp (**Figure 16-52, Page 16-21**).
30. Connect the impulse line to the fuel pump and secure it with the hose clamp (**Figure 16-53, Page 16-21**).
31. Connect air intake hose to carburetor and secure hose clamp (**Figure 16-54, Page 16-21**).
32. Connect carburetor vent tube to carburetor and secure with hose clamp (**Figure 16-55, Page 16-22**).

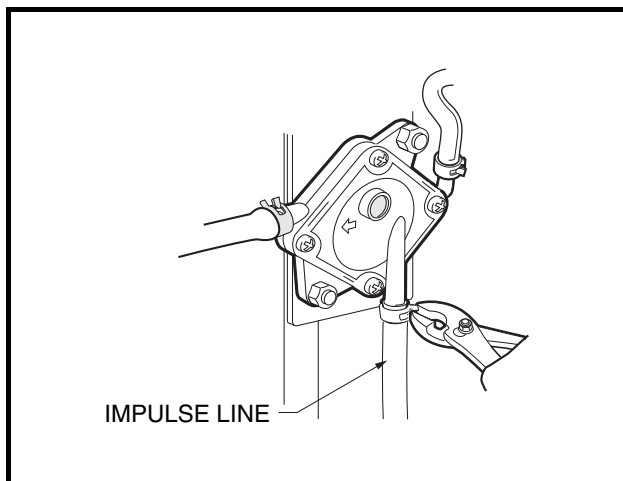


Figure 16-53 Impulse Line

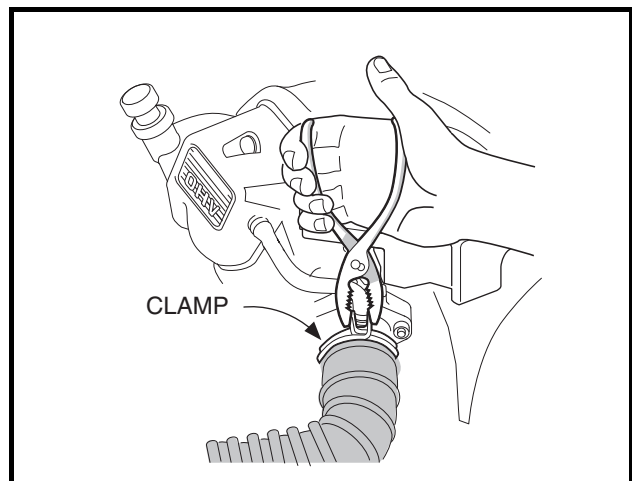
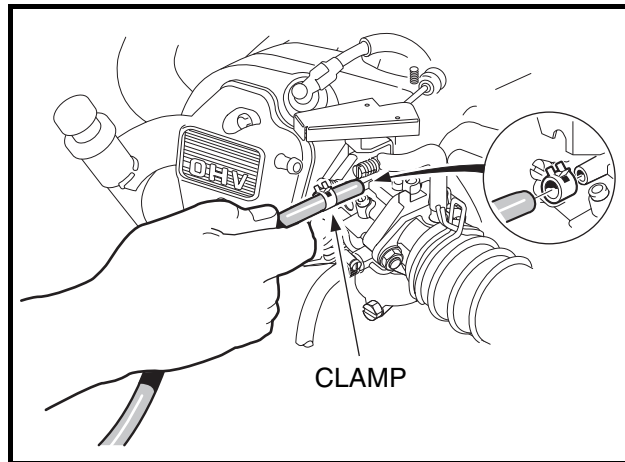


Figure 16-54 Air Intake Hose

33. Connect the differential lock cable end to the differential lock handle.
  - 33.1. Connect the end of the differential lock cable to the differential lock handle (Step 1) (**Figure 16-56, Page 16-22**).
  - 33.2. Push down on the cable to secure the end of the cable to the differential lock handle (Step 2).
  - 33.3. Rotate the cable counterclockwise to route the cable through the bracket (Step 3).
  - 33.4. Push the cable sheath toward the front of the vehicle to secure the cable to the bracket (**Figure 16-60, Page 16-27**).
  - 33.5. Secure the cable to the vertical support with a wire tie (6).

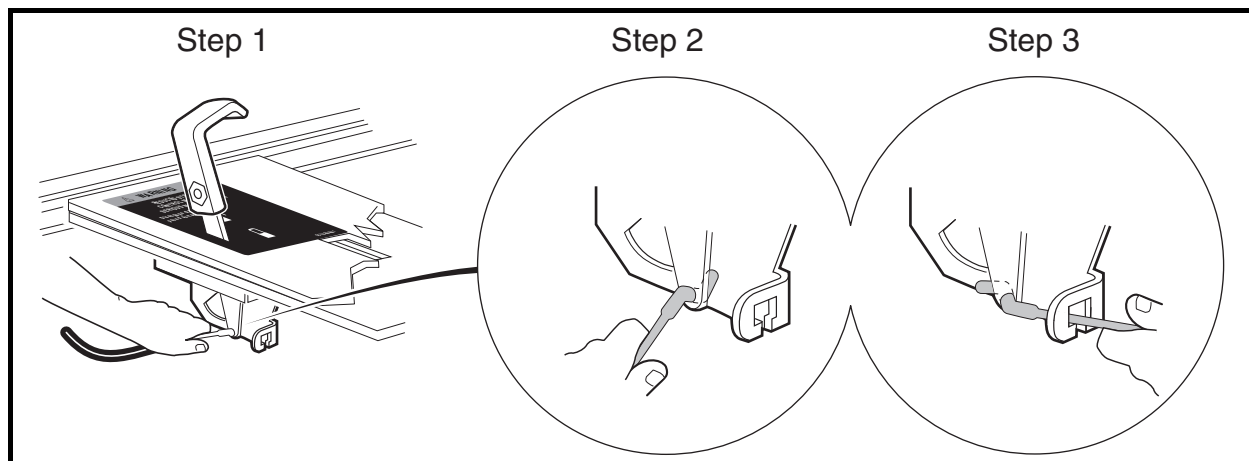
**Unitized Transaxle Installation, Continued:****Figure 16-55 Carburetor Vent Tube**

34. Install transaxle drain plug and tighten to 21 ft-lb (28.5 N·m).
35. Fill transaxle with 29 oz. (.85 liter) 80-90 WT. API Class GL-3 or 80-90 WT. AGMA Class 5 EP gear lubricant. Install and tighten the level indicator hole plug to 21 ft. lb. (28.5 N·m).
36. Check that all wiring is secured properly. **See following WARNING.**

**⚠ WARNING**

- If wires are removed or replaced make sure wiring and wiring harness is properly routed and secured to vehicle frame. Failure to properly route and secure wiring could result in vehicle malfunction, property damage or personal injury.

37. Connect battery and spark plug wire(s). **See Connecting The Battery on page 1-3.**
38. Adjust the engine RPM setting. **See Engine RPM Adjustment, Section 14, Page 14-10.**

**Figure 16-56 Differential Cable End Installation**

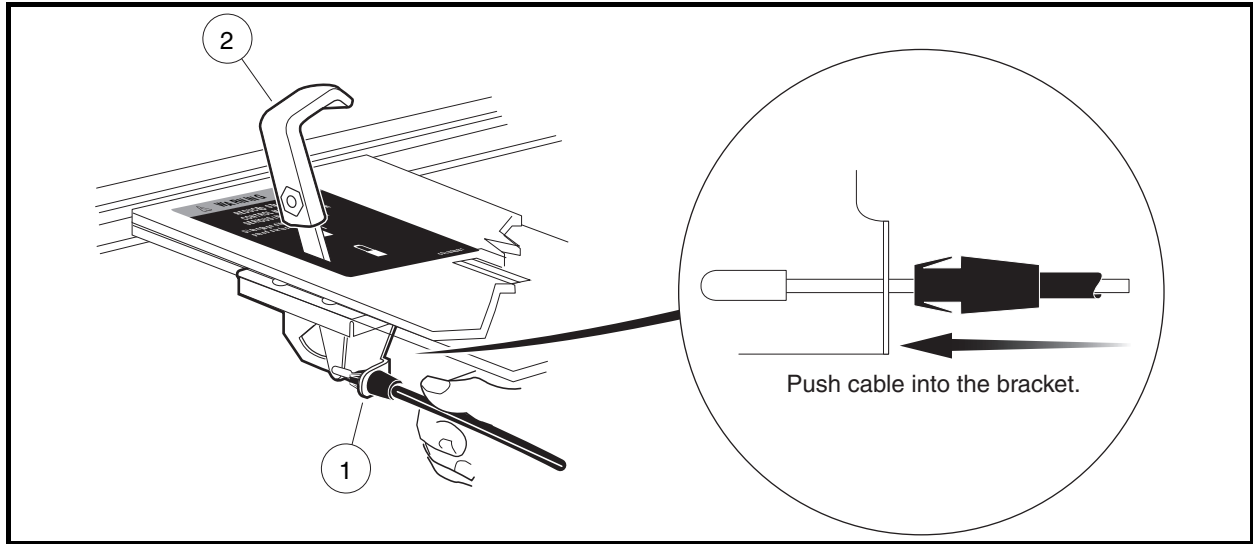


Figure 16-57 Differential Cable Installation

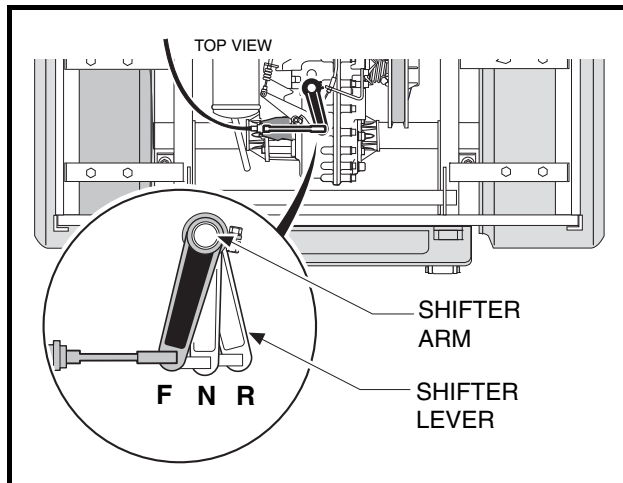


Figure 16-58 Forward/Reverse Positions

## FORWARD/REVERSE SHIFTER CABLE

See General Warning, Section 1, Page 1-1.

If the Forward/Reverse shifter cable is damaged in any way, it must be replaced.

### FORWARD/REVERSE SHIFTER CABLE REMOVAL

**NOTE:** Before removing cable, note cable routing and positions of wire ties or other devices securing the cable to the vehicle. When installed, cable must be routed and secured as it was originally.

1. Remove the ball joint socket (2) from the Forward/Reverse shifter assembly ball stud (3) (Figure 16-59, Page 16-24).
2. Remove the ball joint socket (10) from the shifter arm ball stud (11) on the transaxle.
3. Loosen the retaining nuts (5) on both ends of the cable and remove the wire tie and cable.

## FORWARD/REVERSE SHIFTER CABLE INSTALLATION

1. Route the cable to the transaxle shifter lever, beginning at the Forward/Reverse shifter.
2. Secure the cable with retaining nut (5) on each side of the shifter cable support bracket at the transaxle (**Figure 16-59, Page 16-24**) and tighten nuts to 22 ft-lb (29.8 N·m).
3. Secure the cable with retaining nut (5) on each side of the shifter cable support bracket at the Forward/Reverse assembly and tighten nuts to 22 ft-lb (29.8 N·m).
4. Install the ball joint socket (10) on the shifter lever ball stud (11) on the transaxle.
5. Install the ball joint socket (2) on the Forward/Reverse shifter assembly ball stud (3).
6. Install wire tie (8) to secure wire harness to cable at the support bracket near the Forward/Reverse shifter assembly. **See following WARNING.**

### **⚠ WARNING**

- If wires are removed or replaced, make sure wiring and/or wiring harness is properly routed and secured to vehicle frame. Failure to properly route and secure wiring could result in vehicle malfunction, property damage or personal injury.

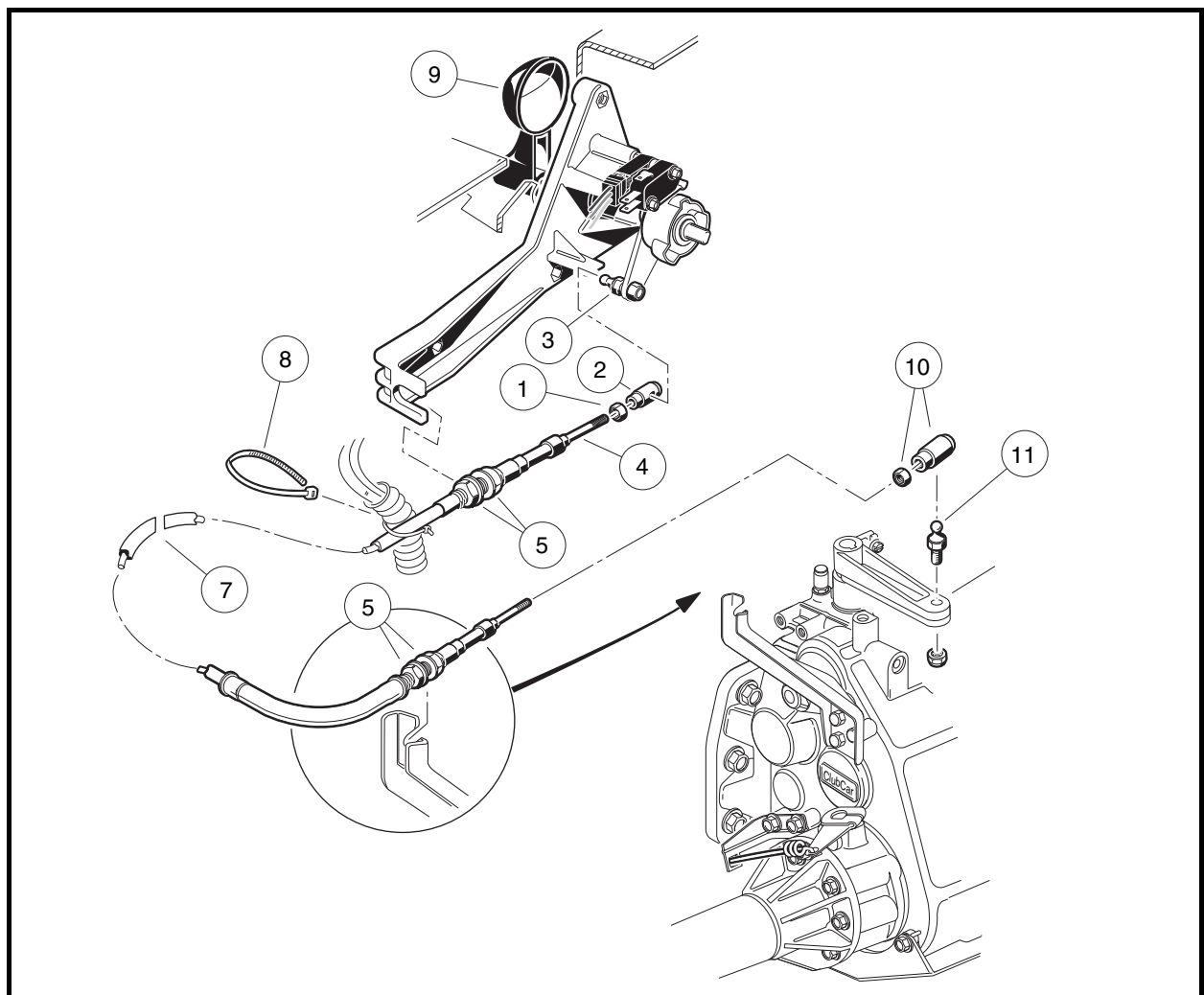


Figure 16-59 Forward/Reverse Shifter Cable



## FORWARD/REVERSE SHIFTER CABLE ADJUSTMENT

Place the shifter lever in the NEUTRAL position (straight up) (**Figure 16-58, Page 16-23**). For minor adjustments, the nut (1) may be loosened and the ball joint socket (2) rotated to get the proper adjustment (**Figure 16-59, Page 16-24**). **See following CAUTION.**

### **▲ CAUTION**

- **Be sure threads of cable are engaged in ball joint socket at least 1/4-inch (6.35 mm). If ball joint socket comes loose from the cable, the Forward/Reverse shifter will not operate properly.**

For major adjustments, the cable retaining nuts (5) must be loosened and adjusted. When the cable is properly adjusted, with the Forward/Reverse handle (9) (**Figure 16-59, Page 16-24**) in the NEUTRAL position, the shifter lever of the transaxle will also be in the NEUTRAL position (**Figure 16-58, Page 16-23**). Retighten nuts to 22 ft-lb (29.8 N·m).

## DIFFERENTIAL LOCK SYSTEM

**See General Warning, Section 1, Page 1-1.**

If the differential lock cable is damaged in any way, it must be replaced. **See following WARNING.**

### **▲ WARNING**

- **If for any reason the differential lock system is not operating correctly, the system must be repaired or replaced before attempting to operate the vehicle. With the differential lock engaged, vehicle turning functions are greatly reduced. Failure to heed this warning could result in loss of vehicle control and severe personal injury.**

## DIFFERENTIAL LOCK SYSTEM INSPECTION

The differential lock system should periodically be inspected for proper operation.

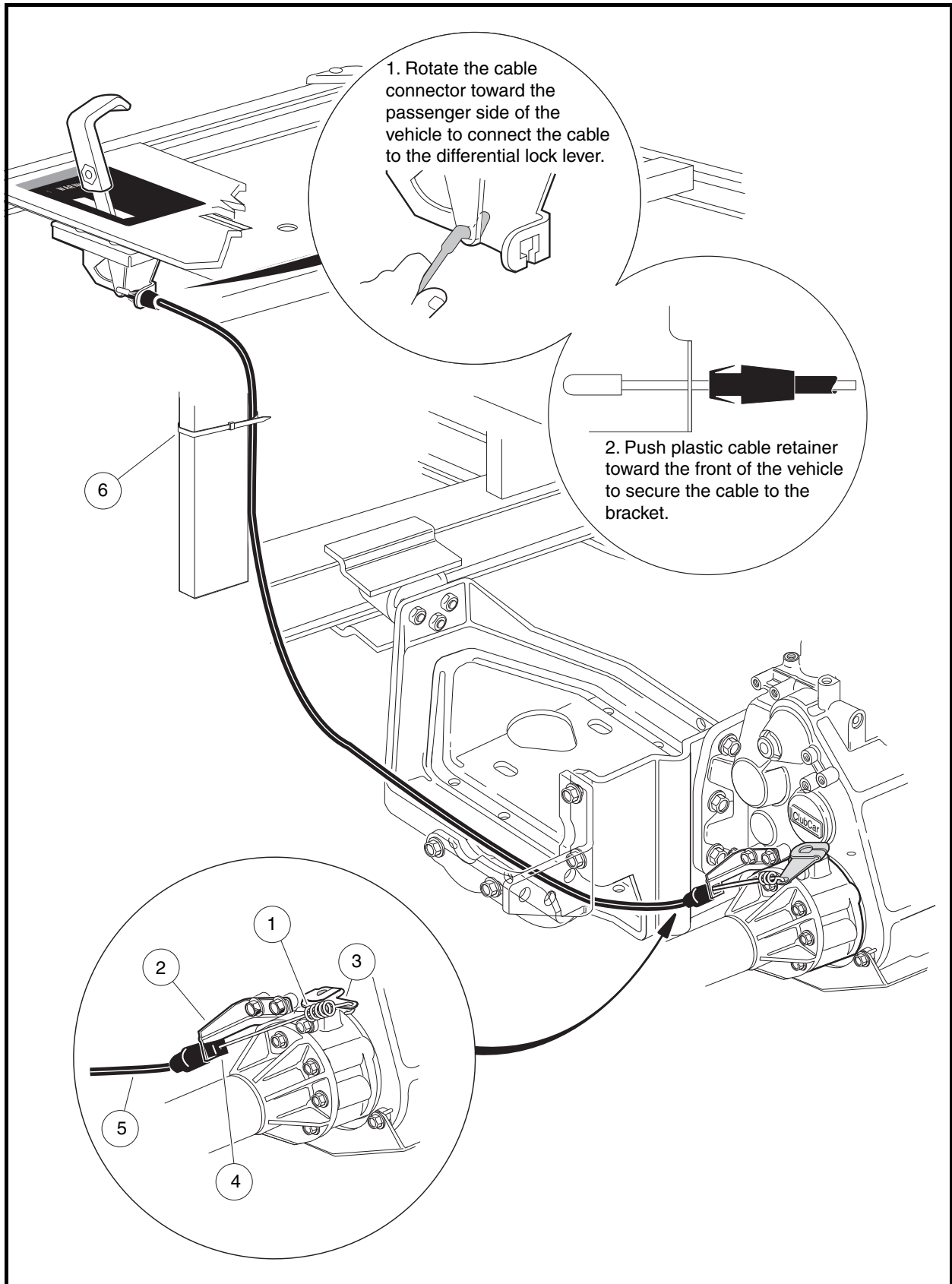
1. Place chocks at the front wheels, lift the rear of the vehicle with a floor jack and place jack stands under the axle tubes to support the vehicle. **See WARNING “Lift only one end...” in General Warning, Section 1, Page 1-1.**
2. With the differential lock handle in the forward position (unlocked), rotate one of the rear wheels by hand. The wheel should be fairly easy to rotate and the other rear wheel should rotate in the opposite direction, indicating that the differential lock is not engaged. If this is not the case, the differential handle, cable or housing must be repaired or replaced before attempting to drive the vehicle.
3. With the wheels at rest, pull the differential lock handle toward the rear of the vehicle (locked position). Observe the cable end and differential lock arm on the differential lock housing. The cable should move freely when the handle is moved. Initially, there may be slack in the cable at the differential housing. Rotation of the rear tire will eliminate this slack when the differential lock is fully engaged.
4. With the differential lock handle in the rear position (locked), rotate one of the rear wheels by hand. The wheel should be harder to rotate than in the unlocked position and the other rear wheel should rotate in the same direction, indicating that the differential lock is engaged. If this is not the case, the differential handle, cable or housing must be repaired or replaced before attempting to drive the vehicle.

## DIFFERENTIAL LOCK CABLE REMOVAL

1. Place the differential lock handle in the disengaged position.
2. Remove wire tie (6) securing the cable to the vertical support (**Figure 16-60, Page 16-27**).
3. Use a pair of pliers and apply pressure to the locking tabs of the cable end (1) where it attaches to the differential lock handle mounting bracket (**Figure 16-12, Page 16-8**).
4. Pull the differential lock cable toward the rear of the vehicle while maintaining pressure on the locking tabs and disconnect the cable from the bracket (**Figure 16-12, Page 16-8**).
5. Rotate the cable connector toward the driver side of the vehicle to disconnect the cable from the differential lock lever (1) (**Figure 16-13, Page 16-8**).
6. Unhook the cable spring (1) from the differential lock arm (3) (**Figure 16-60, Page 16-27**).
7. Use a pair of pliers and apply pressure to the locking tabs of the cable end (4) where it attaches to the cable mounting bracket (2) at the transaxle.
8. Pull cable (5) toward the front of the vehicle to remove the cable from the bracket (2) and vehicle.

## DIFFERENTIAL LOCK CABLE INSTALLATION

1. Route the cable through the engine mounting plate as illustrated (**Figure 16-60, Page 16-27**).
2. Route the cable spring (1) through the cable bracket (2).
3. Connect the differential lock cable spring end (1) to the differential lock arm (3) on the differential lock housing.
4. Push the cable (5) toward the rear of the vehicle in order to secure the cable to the bracket (2).
5. Connect the differential lock cable end to the differential lock handle.
  - 5.1. Connect the end of the differential lock cable to the differential lock handle (Step 1) (**Figure 16-56, Page 16-22**).
  - 5.2. Push down on the cable to secure the end of the cable to the differential lock handle (Step 2).
  - 5.3. Rotate the cable sheath counterclockwise to route the cable through the bracket (Step 3).
  - 5.4. Push the cable toward the front of the vehicle to secure the cable to the bracket (**Figure 16-57, Page 16-23**).
  - 5.5. Secure the cable to the vertical support as shown with a wire tie (6) (**Figure 16-60, Page 16-27**).
6. Inspect the differential lock system for proper operation. **See Differential Lock System Inspection on page 16-25.**

**Figure 16-60 Differential Lock Cable Routing**



# SECTION 17 – TORQUE CONVERTER

---

## **⚠ DANGER**

- See General Warning, Section 1, Page 1-1.

## **⚠ WARNING**

- See General Warning, Section 1, Page 1-1.

## GENERAL INFORMATION

---

The torque converter consists of a drive clutch, a driven clutch, and a drive belt. To provide optimum performance for the OHV engines and powertrain, the vehicle uses a pair of tuned clutches. The drive clutch, which is mounted to the engine, is in the open position when the engine is at idle. At this point, the belt is riding at a low position (smaller diameter) on the drive clutch. The driven clutch, which is mounted to the transaxle, is in the closed position when the engine is at idle. At this point, the belt is riding at its highest position (large diameter).

At the point of clutch engagement, the speed ratio of the drive clutch to the driven clutch is 3.5 to 1. This ratio provides excellent starting and low-speed torque.

As engine speed increases, centrifugal force on internal weights close the drive clutch, pushing the belt up to a higher position on the clutch (increasing the diameter of the belt loop). As the diameter of the belt loop increases at the drive clutch, the driven clutch is forced open as the diameter of its belt loop decreases. At governed top speed, the ratio of drive clutch to driven clutch is 0.92 to 1.

On steep grades, or when the vehicle is heavily loaded, higher torques are achieved through the use of a torque-sensing ramp device on the driven clutch. This device overcomes the force of the centrifugal weights to close the driven clutch and open the drive clutch, thus increasing axle torque with little or no change in engine RPM.

The engine and torque converter rotate clockwise as viewed from the clutch side of the engine.

To properly assemble and disassemble the torque converter, the following tools should be used:

- Torque Converter Tool Kit (CC P/N 1014510) (**Figure 17-1, Page 17-2**)
- Scribe or small pick (not included in torque converter tool kit)

## TROUBLESHOOTING

---

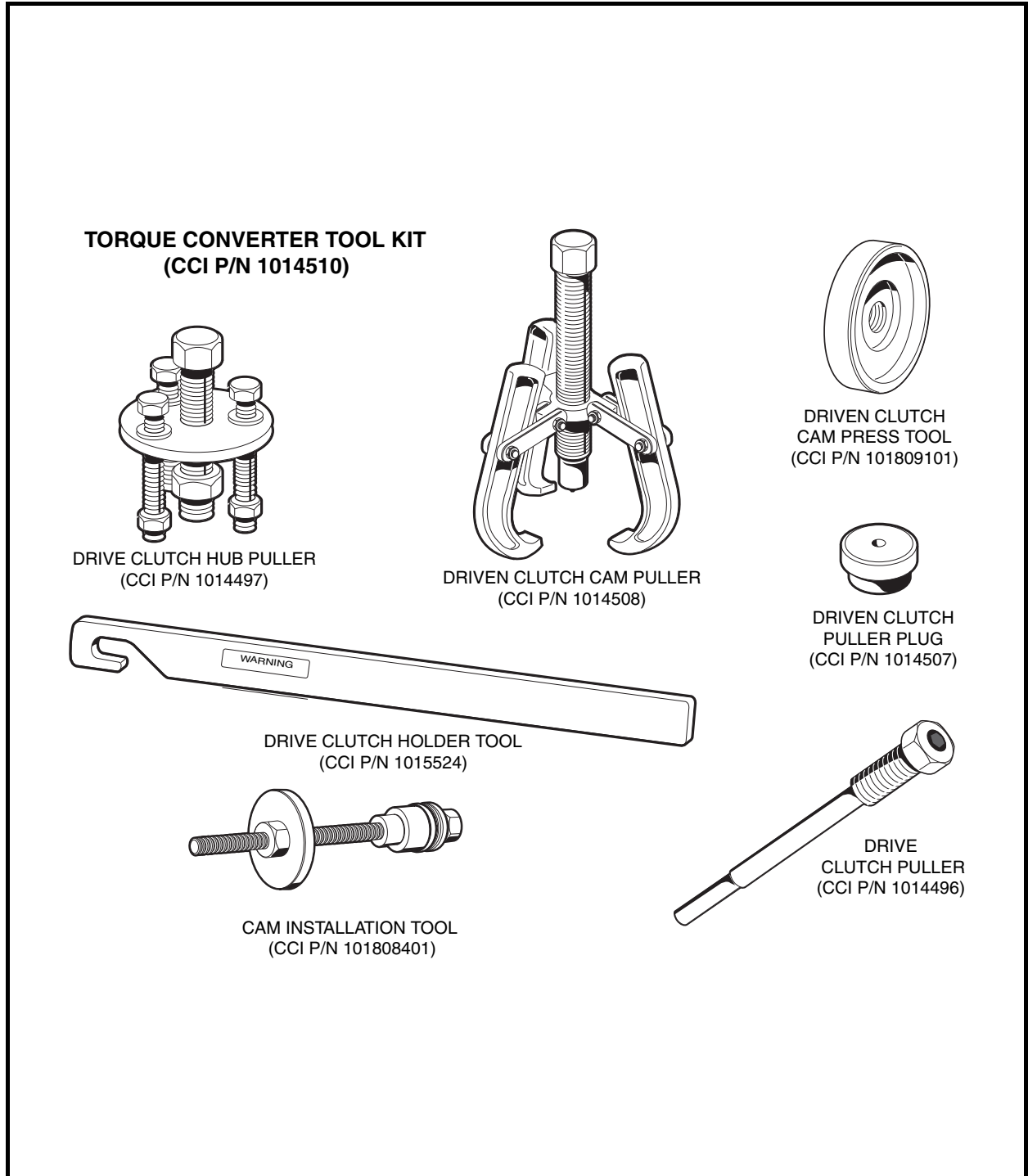
**See General Warning, Section 1, Page 1-1.**

Maintaining proper adjustment of the engine and governor, as well as the torque converter, is essential to the troubleshooting process. If these adjustments are within Club Car specifications and, when climbing a steep hill, the engine begins to lose RPM before the drive belt reaches the top of the driven clutch, there is a torque converter problem.

If the torque converter is not operating properly:

1. Check the governor and throttle settings. **See Governor Cable Installation and Adjustment, Section 14, Page 14-7.**

2. Inspect both clutches for dirt and debris buildup on component parts. Clean the exterior surfaces of both with water to remove any dust or dirt, then drive the vehicle and check for proper operation.
3. If cleaning both clutches does not solve the problem, disassemble and thoroughly clean all parts in the drive clutch. Be sure to clean the plastic drive buttons (10) (**Figure 17-7, Page 17-8**).



**Figure 17-1 Torque Converter Tool Kit**

## DRIVE BELT

See General Warning, Section 1, Page 1-1.

The drive belt should be inspected semiannually for wear and glazing. If it is excessively worn, frayed, or glazed, replace the belt.

As the drive belt wears, the engine RPM will increase to compensate for the change in torque converter ratio. This will keep the vehicle's maximum ground speed correct at 17-19 mph (27-31 km/h).

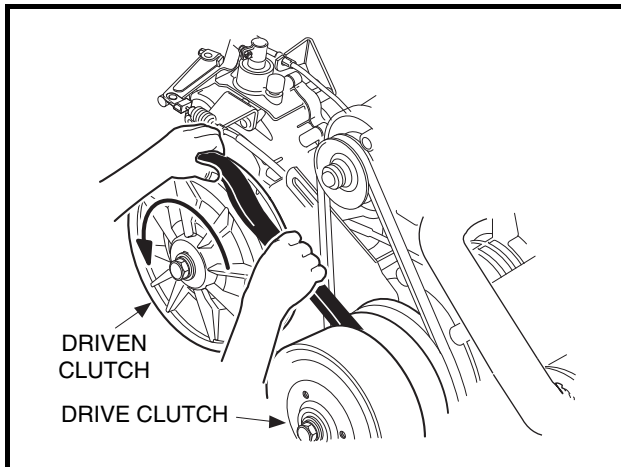


Figure 17-2 Drive Belt Removal

### DRIVE BELT REMOVAL

1. Turn the key switch OFF and remove the key. Place the Forward/Reverse handle in the NEUTRAL position. Chock the wheels.
2. Disconnect battery and spark plug wire(s). **See Disconnecting The Battery on page 1-3.**
3. Grasp the belt midway between the drive and driven clutches. Lift upward on the belt to force the sheaves of the driven clutch apart, then roll the belt off the driven clutch by rotating the clutch counterclockwise (**Figure 17-2, Page 17-3**). **See following CAUTION.**

#### **⚠ CAUTION**

- **Make sure fingers are not underneath the belt when rolling the belt off the driven clutch.**

### DRIVE BELT INSTALLATION

1. Position the new belt on the drive clutch, then start the belt over the top of the driven clutch.
2. With the belt started onto the driven clutch, rotate the driven clutch counterclockwise and roll the belt over the driven clutch sheaves and onto the clutch.
3. Connect battery and spark plug wire(s). **See Connecting The Battery on page 1-3.**

## DRIVE CLUTCH

---

See General Warning, Section 1, Page 1-1.

### **CAUTION**

- Be very careful when handling the clutches. A clutch that has been dropped will not be properly balanced. If either clutch is dropped, assume that it is damaged and replace it.

## DRIVE CLUTCH REMOVAL

1. Turn the key switch OFF and remove the key. Place the Forward/Reverse handle in the NEUTRAL position. Chock the wheels.
2. Disconnect battery and spark plug wire(s). **See Disconnecting The Battery on page 1-3.**
3. Remove the drive belt. **See Drive Belt Removal on page 17-3.**
4. Loosen the starter/generator mounting and adjusting hardware and then remove the starter belt. **See WARNING “Moving parts! Do not...” in General Warning on page 1-2.**
5. Remove the drive clutch retaining bolt (18) and flat washer (19) (**Figure 17-7, Page 17-8**). **See also Figure 17-3, Page 17-5. See following NOTE.**

**NOTE:** *The drive clutch mounting bolt has left-hand threads.*

*The crankshaft has left-hand threads at the clutch mounting hole.*

6. Lubricate threaded portion of clutch puller tool with a light oil and thread the clutch puller tool into the clutch retaining bolt hole.
7. Use a 1/2-inch drive air wrench to tighten the clutch puller tool. The drive clutch will come free of the crankshaft (**Figure 17-4, Page 17-5**).
8. Support the drive clutch assembly in your hand and back the clutch puller tool out of the crankshaft. **See following CAUTION.**

### **CAUTION**

- Do not hit or tap the clutch with a hammer. Do not pry the clutch. These actions will damage the clutch.



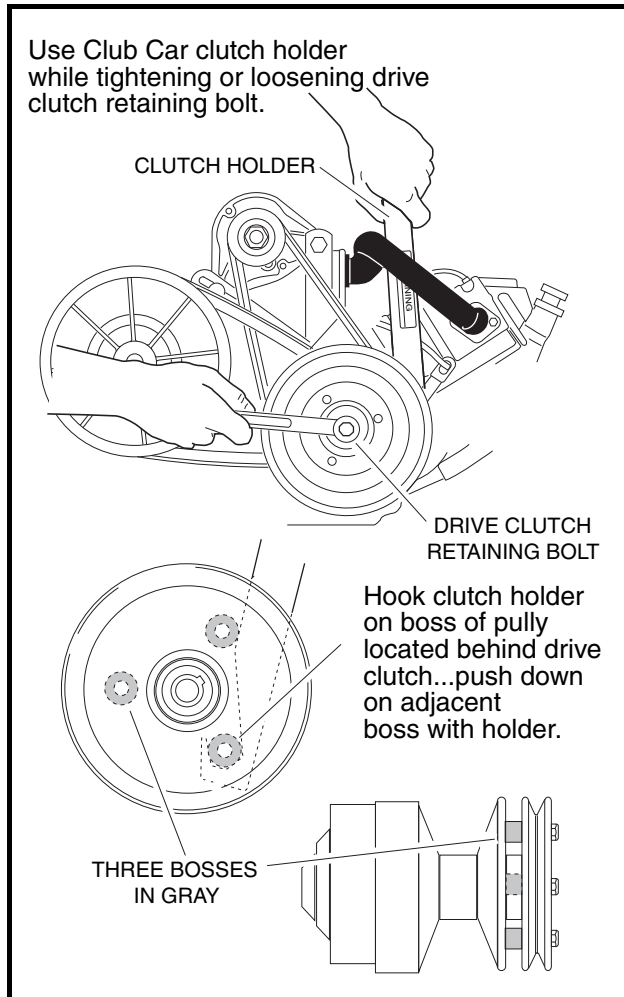


Figure 17-3 Loosen Retaining Bolt

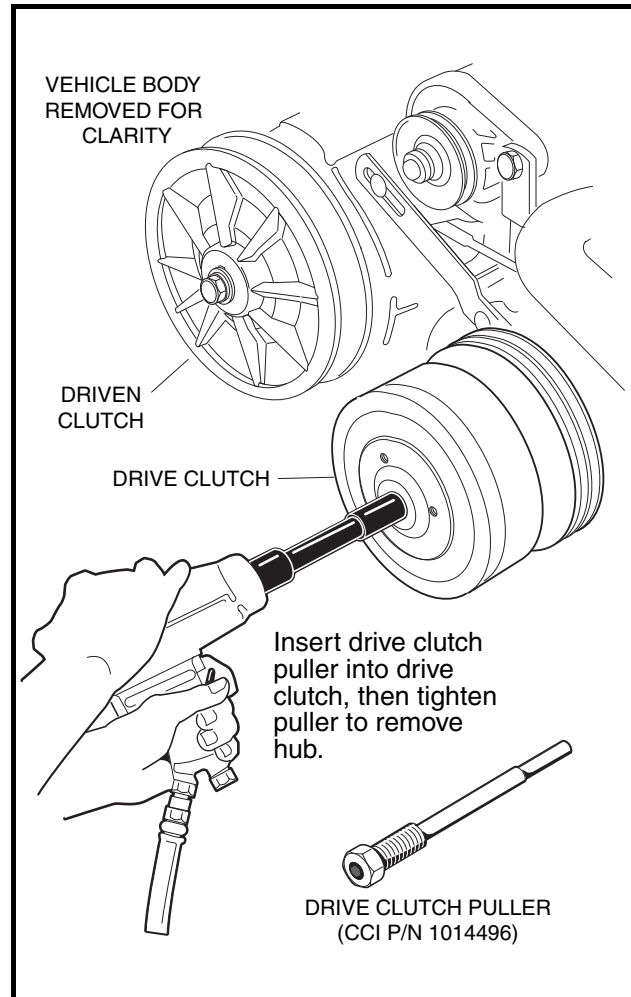


Figure 17-4 Drive Clutch Removal

## DRIVE CLUTCH CLEANING AND INSPECTION

1. Use a dry, lint-free cloth to clean clutch parts. **See following CAUTION.**

### **CAUTION**

- Do not lubricate the drive clutch. Lubricants attract dirt and dust, which interfere with proper clutch operation.
  - Use only a dry cloth to lightly wipe the shaft (2) of the fixed face assembly (Figure 17-7, Page 17-8). Do not use a brush or steel wool. These will damage the surface of the shaft.
  - Do not use solvents. Solvents will damage the lubricating characteristics of the bushings.
2. Inspect the belt contact surfaces of the clutch sheaves for wear. If any area of a sheave contact surface has wear of 0.060-inch (1.52-mm) or more, the clutch should be replaced.

## DRIVE CLUTCH DISASSEMBLY

### CAUTION

- The drive clutch is balanced as an assembly. Before disassembly, make match marks on the clutch cover and on the moveable face assembly so they can be reassembled in the same positions (Figure 17-5, Page 17-6).

1. Make match marks on the clutch drive hub and on the moveable face casting (Figure 17-5, Page 17-6).

**NOTE:** The following procedure applies to the Drive Clutch Hub Puller (CC P/N 1014497). Other types of pullers may vary in operation and sequence of procedure.

2. Remove the clutch drive hub (8) (Figure 17-7, Page 17-8).
  - 2.1. Remove the three plastic plugs (9) from the clutch puller attachment holes in the drive hub (8) (Figure 17-7, Page 17-8).
  - 2.2. Thread the center bolt of the Drive Clutch Hub Puller (CC P/N 1014497) into clutch until the stop nut touches the clutch hub or the bolt bottoms out, then back the bolt out one-half turn (Figure 17-6, Page 17-6).

**NOTE:** The stop nut has been mechanically crimped and locked into position acting as an integrated assembly with the bolt.

- 2.3. Thread the three small bolts of the puller into the puller attachment holes in the clutch. Tighten bolts evenly, making sure the face of the puller plate is parallel to the clutch face (Figure 17-6, Page 17-6).

**NOTE:** The nuts on each of the three, small puller bolts are mechanically crimped and locked into position.

- 2.4. Unscrew the hub puller center bolt from the clutch, forcing the stop nut up against the puller plate, lifting the drive hub (8) from the fixed face shaft (2) (Figure 17-7, Page 17-8).
3. Remove the thrust washer (11) from the moveable face (13).
4. Remove the drive buttons.
  - 4.1. Remove the screws, flat washers, drive button take-up spring, and drive buttons (Figure 17-8, Page 17-9).

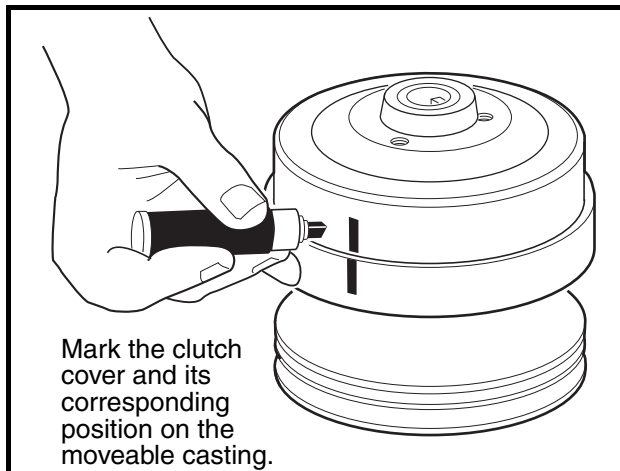


Figure 17-5 Mark Clutch Cover

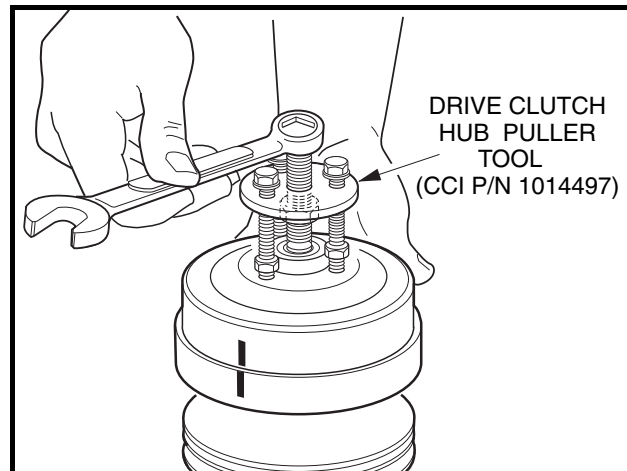


Figure 17-6 Remove Clutch Drive Hub

5. Remove the clutch weights.
  - 5.1. Remove the screws and flat washers attaching the weights (**Figure 17-9, Page 17-9**).
  - 5.2. Pull the weight assemblies, with pins, from the clutch.
  - 5.3. Remove the plastic washers, weights and wave washer from the pins. Before removing, note the orientations of the wave washer and of the primary and secondary weights to one another (**Figure 17-12, Page 17-10 and Figure 17-13, Page 17-10**). Retain all parts.
6. Remove the retaining ring (7) from the shaft of the fixed face assembly (2) and slide the moveable face (13) off the shaft (**Figure 17-7, Page 17-8**). **See following NOTE.**

**NOTE:** *When the moveable face is removed from the hub of the fixed face, the spiral back-up rings (12) must be replaced with new ones at time of reassembly (**Figure 17-7, Page 17-8**).*

7. Remove the spacer (6), spring (5) and retainer (4). The spring retainer (4) can be removed from the spring if necessary (**Figure 17-7, Page 17-8**).
8. Remove idler bearing if necessary. Use a press to remove the bearing (**Figure 17-10, Page 17-9**). **See following NOTE.**

**NOTE:** *Do not remove the idler bearing unless it needs to be replaced. If idler bearing is removed, replace it with a new bearing.*

9. Use a scribe or small pick to remove the spiral backup rings (12) from each end of the bore in the fixed face assembly (**Figure 17-7, Page 17-8**). **See also Figure 17-11, Page 17-9.** Discard the rings.

## INSPECTION OF DRIVE CLUTCH PARTS

1. Inspect the idler bearing (3) for smooth rotation or seal damage (**Figure 17-7, Page 17-8**).

**NOTE:** *It is normal for a small amount of grease to be present at the edge of seal.*

2. Inspect the bore of the moveable face assembly (13) for scarring or wear. The moveable face assembly must be replaced if the bore is worn to a diameter of 0.883-inch (22.4-mm) or larger (**Figure 17-7, Page 17-8**).
3. Inspect the steel shaft (2) on the fixed face assembly. There should be no noticeable wear anywhere on the shaft. Replace the shaft if it is worn, scratched, or damaged.
4. Inspect the thrust washer (11) for wear. If it is worn more than 0.030-inch (0.76-mm), turn it over or replace it with a new one.
5. Inspect the primary weights and the hub casting for wear. If the primary weights show signs they are touching the casting, the tips of the weights have worn beyond specification and they must be replaced (**Figure 17-12, Page 17-10**).
6. Inspect the pins on the primary weights. There should be no noticeable wear. Replace them if they are worn, scratched, or damaged.
7. Inspect the drive belt pulley sheaves for excessive wear or damage. If the sheaves are excessively worn or damaged, replace the entire fixed face drive assembly.

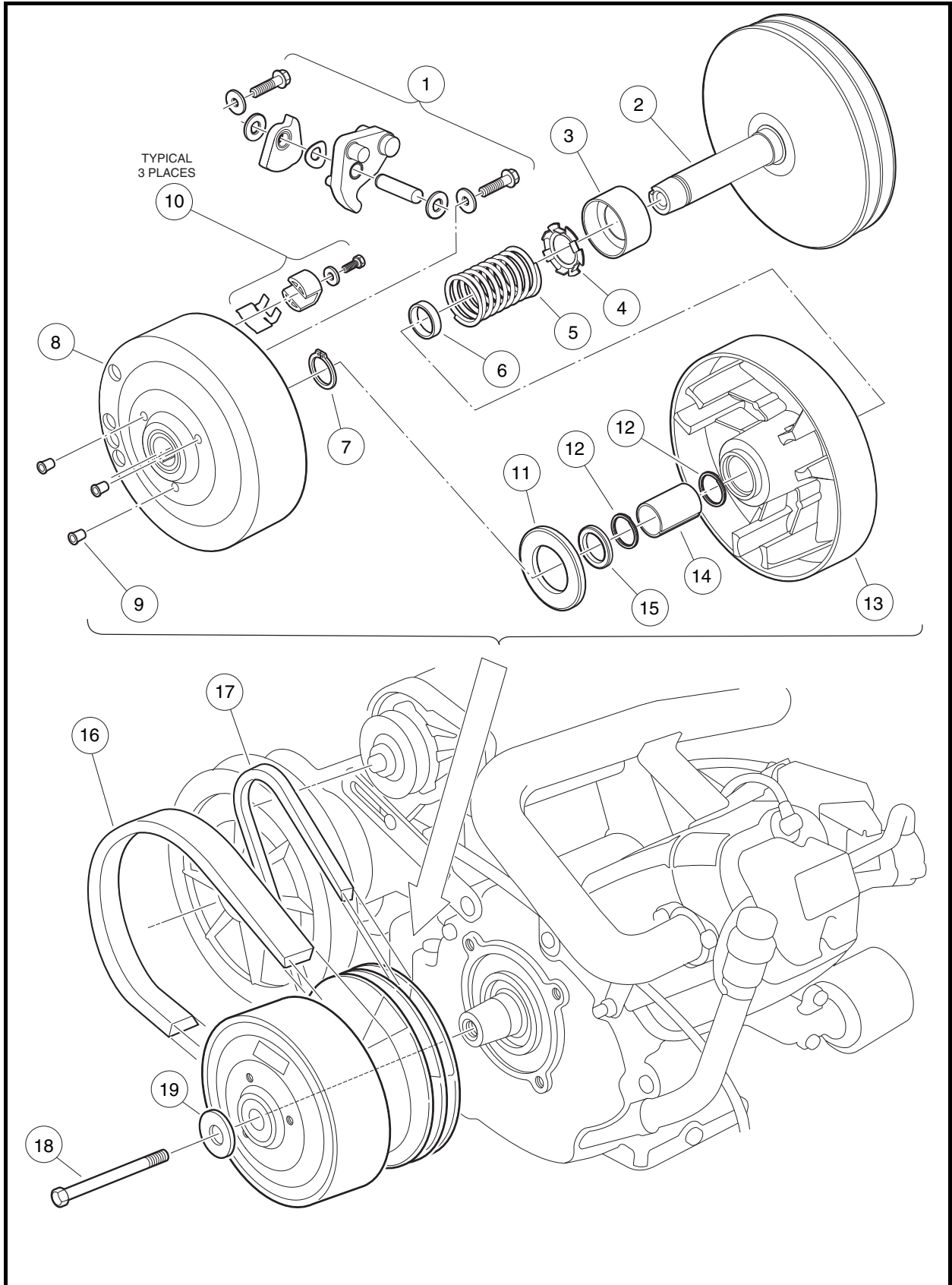


Figure 17-7 Drive Clutch Assembly

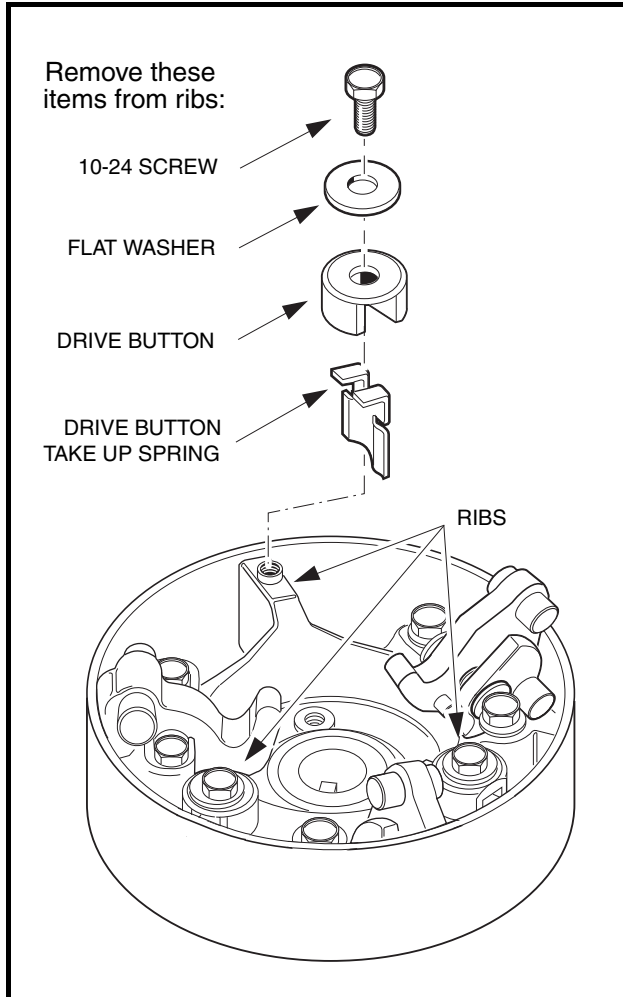


Figure 17-8 Drive Button Mounting

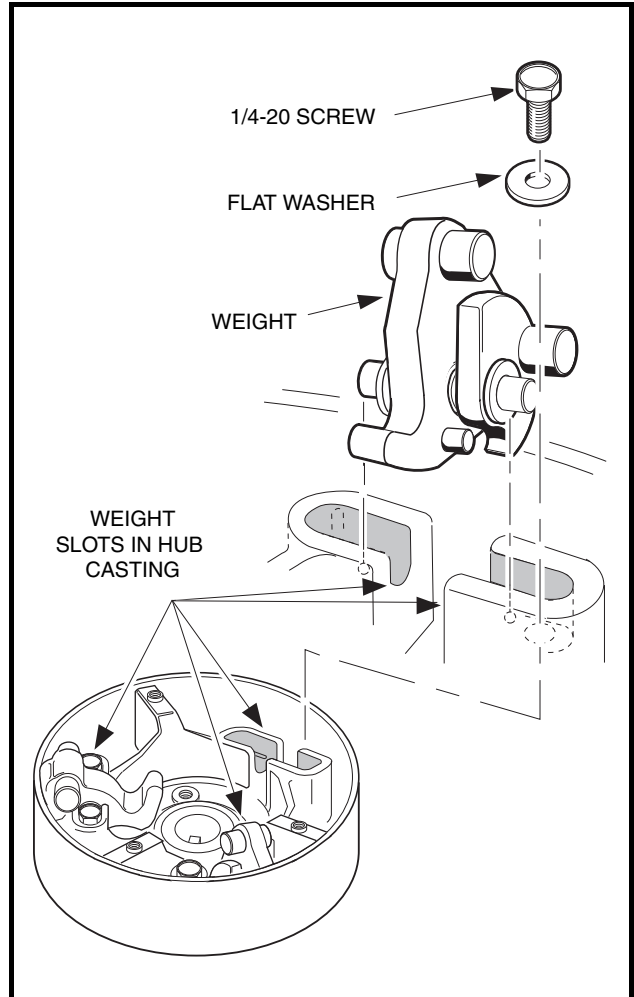


Figure 17-9 Weight Position

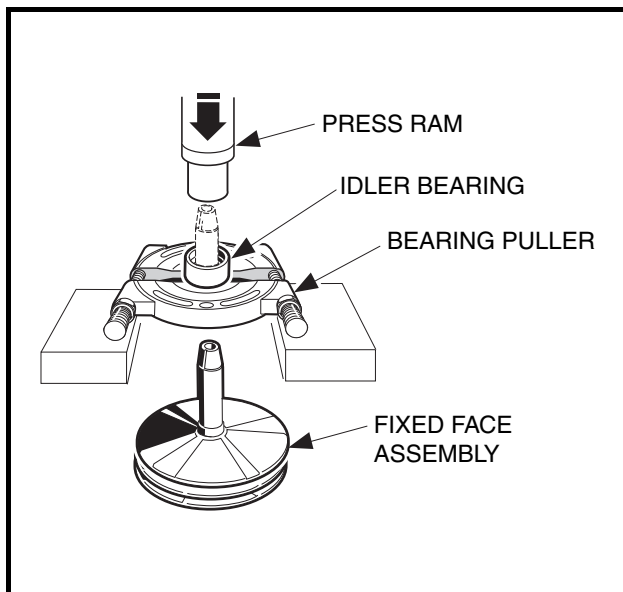


Figure 17-10 Remove Idler Bearing

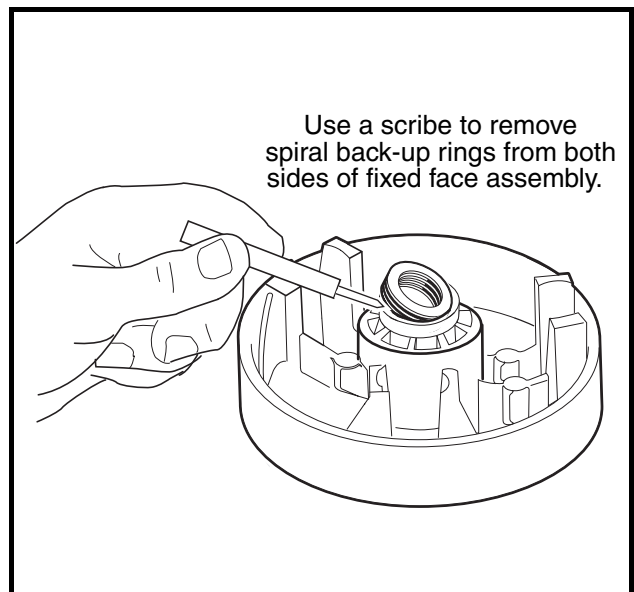


Figure 17-11 Spiral Back-up Rings

## DRIVE CLUTCH ASSEMBLY

1. Press idler bearing (3) onto the shaft of the fixed face assembly (2). Press on the inner race of the bearing only. Make sure that the cup side of bearing is facing away from the fixed face (**Figure 17-7, Page 17-8**).
2. Use a needle nose pliers to install the spring retainer (4) onto the spring (5).
3. Install the spring (5) and retainer (4) into the cup of the idler bearing (3).
4. Install the spacer (6) onto the shaft of the fixed face.
5. Install a new spiral backup ring (12) in each end of the bore of the moveable face assembly (13).
6. Install the moveable face assembly (13) onto the shaft of the fixed face assembly (2). **See following CAUTION.**

### CAUTION

- To avoid damaging the spiral back-up rings, be very careful when installing the moveable face.

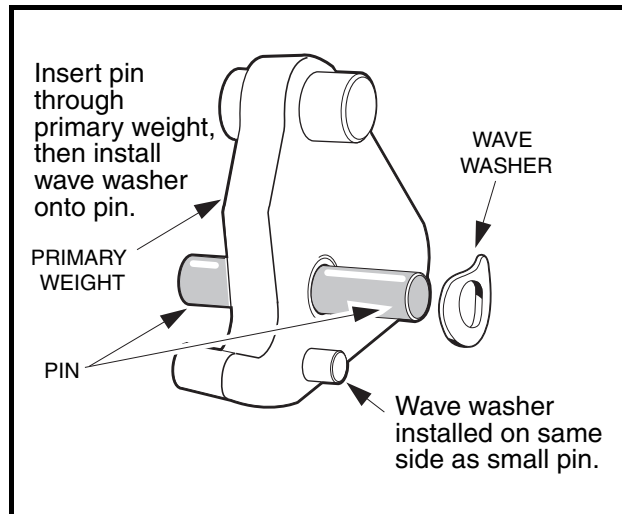


Figure 17-12 Install Pin and Washer

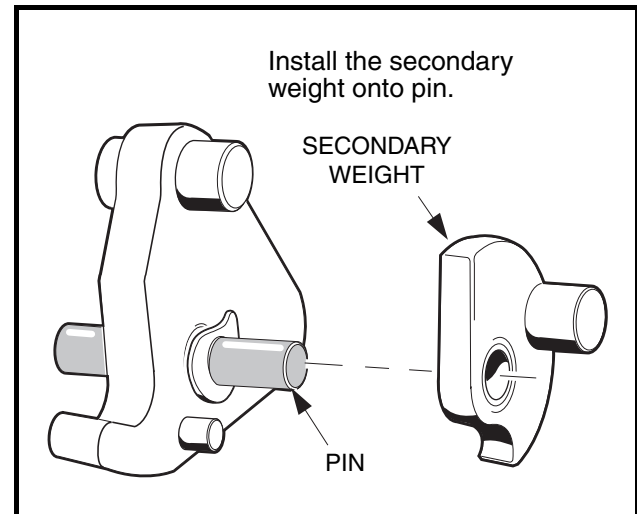
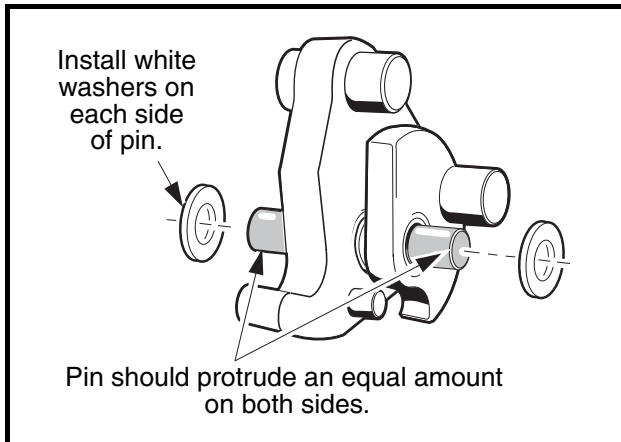


Figure 17-13 Install Secondary Weight

- 6.1. Rotate the moveable face assembly clockwise while installing it onto the shaft.
- 6.2. Install the retaining ring (7) (**Figure 17-7, Page 17-8**).
7. Install the primary weights on the mounting pins (**Figure 17-12, Page 17-10**).
8. Install a wave washer on each mounting pin. Make sure that the concave side of the washer faces the side of the primary weight with the small guide pin protruding from it (**Figure 17-12, Page 17-10**).
9. Install the secondary weights onto the mounting pins with the weight pins on the secondary weights pointing away from the primary weights. The wave washers should be between the primary and secondary weights (**Figure 17-13, Page 17-10**).
10. Install white plastic flat washers on each end of the mounting pin and push them against the outside surfaces of the weights. Center the weights and washers on the mounting pin (**Figure 17-14, Page 17-11**).
11. Install the weight assemblies into the slots in the hub casting (**Figure 17-9, Page 17-9**). Make sure the mounting pin protrudes an equal amount on each side of the weights when the assemblies are in position (**Figure 17-14, Page 17-11**).



**Figure 17-14 Install White Washers**

12. Install the 1/4-20 screws and washers (1) and tighten them to 10 ft-lb (13 N·m) (**Figure 17-7, Page 17-8**).  
**See following NOTE.**

**NOTE:** Make sure there is at least a (minimum) gap of 0.020-inch (0.51-mm) between each end of the mounting pin and the mounting screw.

13. Install three drive button take-up springs.
  - 13.1. Install each spring on right-hand side of the three button mounting posts (when looking into the interior of the clutch drive hub, and with a rib at a twelve o'clock position) as shown (**Figure 17-15, Page 17-12**).
14. Compress each take-up spring and install the drive button over the rib and take-up spring (**Figure 17-8, Page 17-9**).
15. Install a no. 10-24 button retaining screw with flat washer through each button and into the rib. Tighten the screws to 34 in-lb (3.8 N·m) (**Figure 17-9, Page 17-9**).
16. Install the thrust washer (11) onto the moveable face assembly (**Figure 17-7, Page 17-8**).
17. Install the hub assembly (8) on the moveable face assembly and align the match marks made before disassembling the clutch. Press the hub assembly on by hand.
18. Replace the three plastic plugs (9) into the hole protectors (**Figure 17-7, Page 17-8**).

## DRIVE CLUTCH INSTALLATION

1. Place the drive clutch assembly on the crankshaft taper. Position the flat washer (19) on the bolt (18) and start the bolt into the crankshaft (**Figure 17-7, Page 17-8**). **See following NOTE.**

**NOTE:** The drive clutch retaining bolt has left-hand threads. The manufacturer recommends replacing the drive clutch retaining bolt (CC PN 103345701) when installing the drive clutch. If a new bolt is not available, clean the threads of the original bolt and apply Loctite® 242 to the threaded end prior to installation.

2. Tighten the drive clutch retaining bolt (17) to 25 ft-lb (33.9 N·m).
3. Install the starter/generator belt and adjust belt tension as instructed. **See Starter/Generator Installation, Section 12, Page 12-9.** Tighten the starter/generator mounting hardware to 23 ft-lb (31.2 N·m) and the adjusting hardware to 13 ft-lb (17.6 N·m).

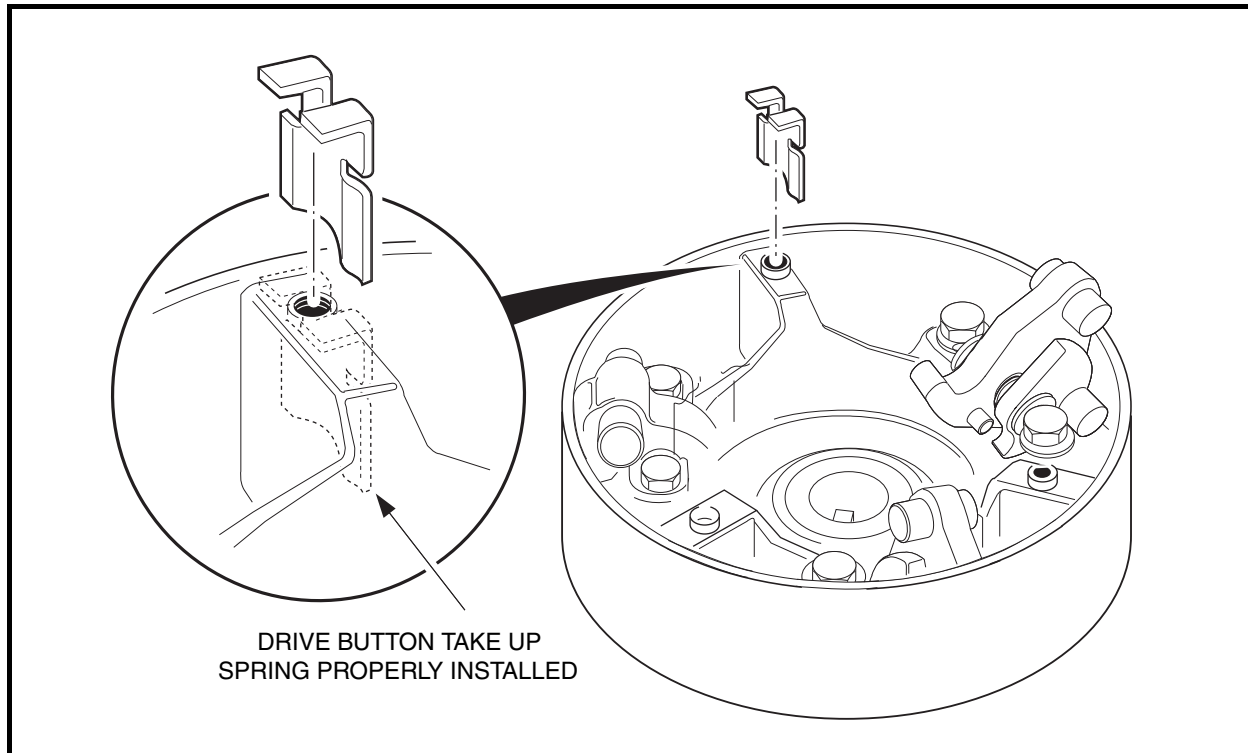


Figure 17-15 Correct Orientation of Drive Button Take-up Spring

4. Install the drive belt as instructed. **See Drive Belt Installation on page 17-3.**
5. Connect battery and spark plug wire(s). **See Connecting The Battery on page 1-3.**
6. Drive the vehicle and check for proper operation.

## DRIVEN CLUTCH

**See General Warning, Section 1, Page 1-1.**

### DRIVEN CLUTCH REMOVAL

1. Turn the key switch OFF and remove the key. Place the Forward/Reverse handle in the NEUTRAL position. Chock the wheels.
2. Disconnect battery and spark plug wire(s). **See Disconnecting The Battery on page 1-3.**
3. Remove the drive belt as instructed. **See Drive Belt Removal on page 17-3.**
4. Remove the bolt (11) and mounting washer (12) from the clutch shaft (**Figure 17-16, Page 17-14**).
5. Grasp the driven clutch assembly and slide it off the shaft.
6. Leave the key (9) in the keyway (**Figure 17-16, Page 17-14**).

### DRIVEN CLUTCH DISASSEMBLY

1. Using external snap ring pliers, remove the retaining ring (2) (**Figure 17-17, Page 17-15**). **See following WARNING.**



### **WARNING**

- **Do not place fingers under the cam when removing the cam. The moveable face may spin when the cam buttons release from the cam ramps, resulting in severe personal injury.**
2. Insert a puller plug (CC P/N 1014507) (**Figure 17-18, Page 17-15**) into the shaft bore and use a driven clutch cam puller (CC P/N 1014508) to remove the cam (4) from the fixed face shaft (8). Retain the key (3) (**Figure 17-16, Page 17-14**).
  3. Remove the spring (5) (**Figure 17-16, Page 17-14**).
  4. Slide the moveable face (7) off the fixed face shaft (8) (**Figure 17-16, Page 17-14**).

### **DRIVEN CLUTCH INSPECTION**

1. Inspect the cam (4) for excessive wear. Replace it if necessary (**Figure 17-16, Page 17-14**).
2. Inspect the drive buttons (6) for excessive wear. Replace if necessary. To remove the drive buttons, remove the socket-head cap screws and then the buttons.
3. Inspect the smooth surface on the fixed and moveable face assemblies. Assemblies must be replaced if surfaces are worn more than 0.060-inch (1.5-mm).
4. Inspect the bronze bearing in the moveable face. If the bearing bore diameter is more than 1.384-inch (35.15-mm), the entire moveable face assembly must be replaced.
5. Inspect the shaft of the fixed face assembly. There should be no noticeable wear. Replace the shaft if it is worn, scratched or damaged.

### **DRIVEN CLUTCH ASSEMBLY**

1. Place the three drive buttons (6) in position. Apply one drop of Loctite<sup>®</sup> 222 to each of the socket head cap screws and then install and tighten them to 8 in-lb (0.9 N·m) (**Figure 17-16, Page 17-14**).
2. Slide the moveable face assembly (7) onto the fixed face shaft (8).
3. Place the end of the spring (5) into hole in the moveable face assembly.
4. Install the key (3) into the keyway of the fixed face assembly (8) shaft.
5. Holding the cam (4) in position for assembly on the shaft, install the other end of the spring (5) into the center spring hole of the cam. Rotate the cam until the keyway is aligned with the key (3) on the fixed face assembly, and then start the cam onto the shaft approximately 1/4 to 3/8-inch (6.3 to 9.5-mm).

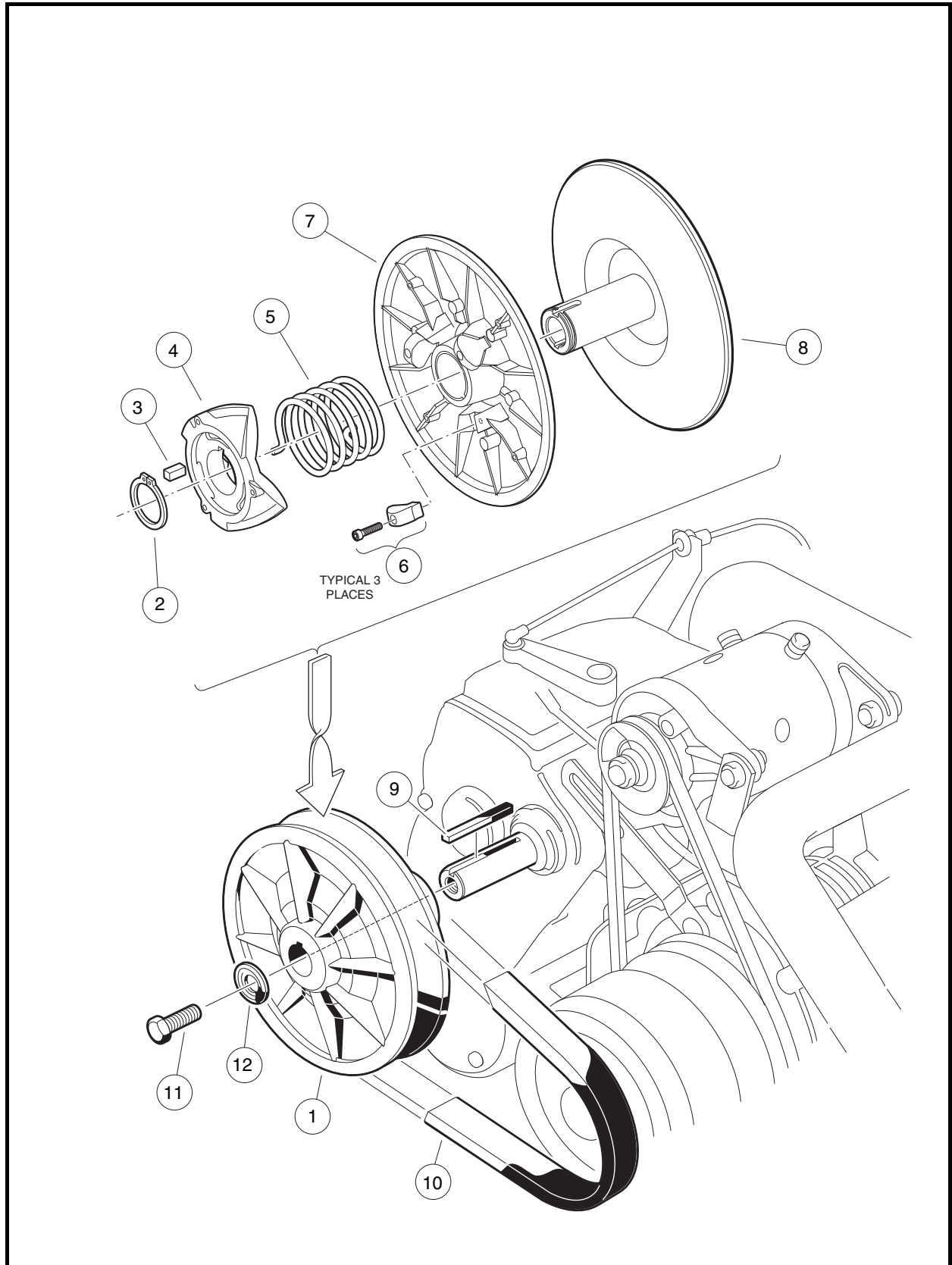


Figure 17-16 Driven Clutch Assembly

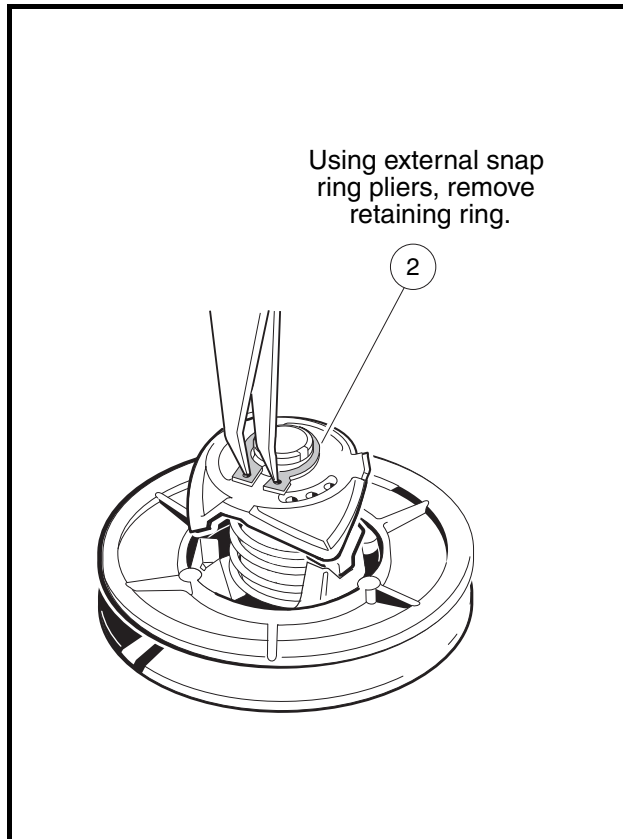


Figure 17-17 Remove Retaining Ring

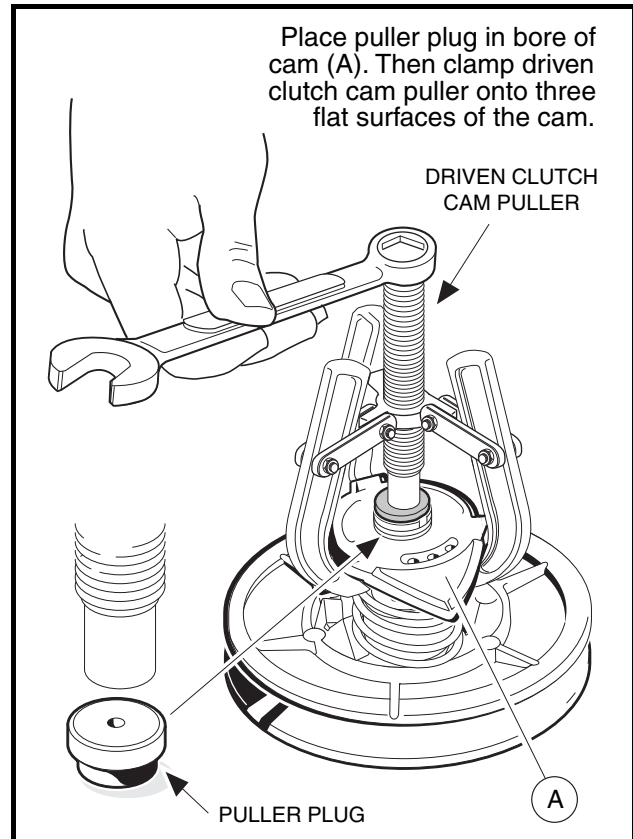


Figure 17-18 Driven Clutch Disassembly

### 5.1. Press Assembly Process:

- 5.1.1. Place the clutch assembly in a press and position the cam press tool (CC P/N 101809101) on the cam as shown (Figure 17-19, Page 17-16).
- 5.1.2. Hold the fixed face assembly (3) and rotate the moveable face assembly (1) one-third turn clockwise, then press the cam (2) onto the fixed face assembly (Figure 17-19, Page 17-16).
- 5.1.3. Install the retaining ring (2) (Figure 17-16, Page 17-14). See following NOTE.

**NOTE:** The cam has an interference fit with the keyed shaft and should remain in position when the cam installation tool is removed, providing for the assembly of the retaining ring.

The retaining ring can be reused provided the O.D. does not exceed 1.607 inches (40.82 mm). Otherwise it must be replaced with a new ring (CC P/N 1014080).

- 5.1.4. While holding onto the cam, tap the end of the fixed face shaft lightly with a plastic mallet until the cam seats against the retaining ring. See following CAUTION.

### **CAUTION**

- Do not use a metal hammer to tap the fixed face hub. A metal hammer will damage the shaft.

### 5.2. Field Assembly Process:

**NOTE:** This process is for field or remote assembly requirements where hydraulic and pneumatic press equipment is not available. Use the Cam Installation Tool (CC P/N 101808401) for this process (Figure 17-20, Page 17-16).

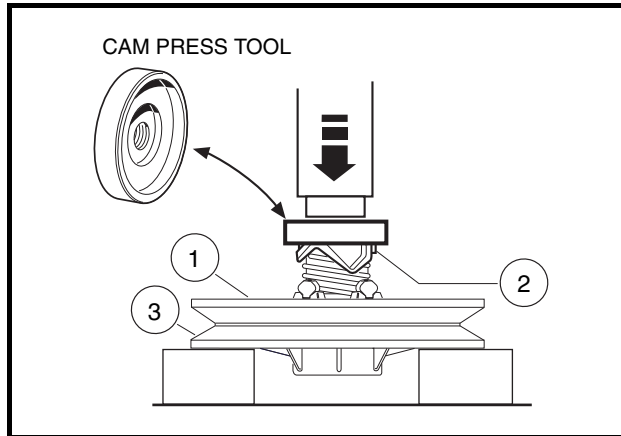


Figure 17-19 Cam Press Tool

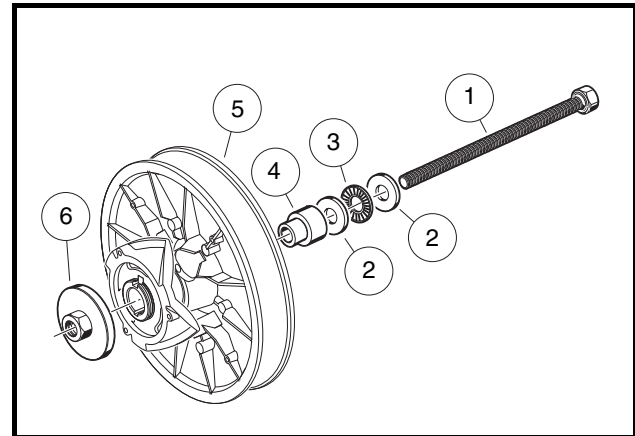


Figure 17-20 Cam Installation Tool

- 5.2.1. With the clutch loosely assembled, set the edge of the clutch body (5) on a clean, flat surface.
- 5.2.2. Assemble the threaded bolt (1) through the washer (2), the thrust bearing assembly (3), the second washer (2), and the hub guide (4) (Figure 17-20, Page 17-16).

**NOTE:** It is very important that the bolt, washers and thrust bearing assembly be assembled in the order described and shown.

- 5.2.3. Slide the bolt (1) through the clutch body (5) until the threaded bolt, washers, bearing, and hub guide are against the fixed face hub (Figure 17-20, Page 17-16).
- 5.2.4. Hold the clutch assembly and cam installation tool together and place the fixed face down on spaced blocks as illustrated (Figure 17-19, Page 17-16).
- 5.2.5. Place the cam press hub (6) onto the cam installation bolt and thread it down onto the cam hub, centering the press hub onto the cam hub.
- 5.2.6. Hold the fixed face assembly of the clutch (5) and rotate the moveable face of the clutch one-third turn clockwise.
- 5.2.7. Use two wrenches, and hold the bolt head while tightening the cam press hub (6), pressing the cam onto the keyed shaft. Advance the press hub until it is firm against the shaft end.
- 5.2.8. Remove the cam press hub (6) and installation tool, and install the retaining ring.

**NOTE:** The cam has an interference fit with the keyed shaft and should remain in position when the cam installation tool is removed, providing for the assembly of the retaining ring.

The retaining ring can be reused provided the O.D. does not exceed 1.607 inches (40.82 mm). Otherwise it must be replaced with a new ring (CC P/N 1014080).

- 5.2.9. While holding onto the cam, tap the end of the fixed face shaft lightly with a plastic mallet until the cam seats against the retaining ring. **See following CAUTION.**

### **CAUTION**

- Do not use a metal hammer to tap the fixed face hub. A metal hammer will damage the shaft.

## DRIVEN CLUTCH INSTALLATION

1. To install the driven clutch, reverse the removal procedure. Make sure that the washer (12) is mounted with the flat portion of the washer against the driven clutch as shown (**Figure 17-16, Page 17-14**). Secure with a *new* bolt (11). **See following NOTE.**

**NOTE:** *The bolt (11) must be replaced with a new bolt (CC P/N 102242101) containing a locking patch that will prevent the bolt from loosening.*

2. Tighten the bolt (11) to 18 ft-lb (24 N·m).
3. Connect battery and spark plug wire(s). **See Connecting The Battery on page 1-3.**



**A**

**accelerator**  
 pedal  
     adjustment .....5-6  
     removal .....5-5  
**air filter** .....14-18  
**axle**  
 bearing  
     installation .....16-5  
     removal .....16-3

**B**

**battery**  
 hydrometer test .....11-11  
 installation .....12-43  
 load test .....11-13  
 storage .....12-43  
 testing .....11-11, 11-33  
 voltage test .....11-12  
**belt, drive**  
 see drive belt  
**body, front**  
 components .....4-3  
 installation .....4-5  
**brakes**  
 adjuster, rear  
     installation .....6-22  
 bell crank  
     installation .....6-28  
     removal .....6-28  
 cluster  
     inspection .....6-3  
     replacement .....6-17  
 cluster, front  
     removal .....6-17  
 hose assembly, front  
     removal .....6-24  
 hydraulic system  
     bleeding .....6-31  
     purging .....6-32  
 line, rear  
     installation .....6-25  
 master cylinder  
     see master cylinder  
 pedal  
     inspection .....6-1  
     troubleshooting .....6-3  
 wheel cylinder, front  
     removal .....6-19  
**brush guard**  
 removal .....4-2

**bumper, tube**

installation .....4-2  
 removal .....4-2

**C**

**cargo bed**  
 bumper adjustment .....4-13  
**CAUTION**  
 definition of .....1-1  
**cleaning**  
 vehicle body .....4-1  
**column, steering**  
 assembly .....7-4

**D**

**DANGER**  
 definition of .....1-1  
**dashboard**  
 removal .....4-3  
**differential lock**  
 system inspection .....16-25  
**diode**  
 testing .....11-20  
**diode, headlight**  
 testing .....11-39  
**drive belt**  
 installation .....17-3  
 removal .....17-3

**E**

**electrical system**  
 circuits .....11-5  
 electrical testing .....11-5  
 FE400 and key-start .....11-5  
 lockout cam circuit .....11-5  
**exhaust system**  
 muffler .....15-1  
     installation .....15-1  
     removal .....15-1

**F**

**fender, front**  
 installation .....4-5  
**filter, air** .....14-18  
**front body**  
 see body, front  
**fuel filter**  
 installation .....14-19  
 removal .....14-18  
**fuel gauge/hour meter**  
 fuel gauge circuit  
     testing .....11-34

- fuel level sending unit  
testing ..... 11-33
- hour meter circuit  
testing ..... 11-37  
operation ..... 12-31
- fuel gauge/hour meter (gasoline vehicles)**  
operation ..... 12-31
- fuel level sending unit**  
testing ..... 11-33
- fuel lines** ..... 14-27
- fuel pump**  
installation ..... 14-21  
removal ..... 14-19
- fuel tank**  
installation ..... 14-26  
removal ..... 14-22
- fuse**  
testing ..... 11-13
- G**
- generator circuit**  
troubleshooting ..... 11-22
- ground cables**  
testing ..... 11-14
- H**
- headlight switch**  
testing ..... 11-38
- headlights**  
*see also* lighting circuit  
testing ..... 11-40
- hydrometer test** ..... 11-11
- I**
- ignition**  
testing ..... 11-23
- ignition coil**  
testing ..... 11-24
- inspection**  
brake cluster ..... 6-3  
brake pedal ..... 6-1  
differential lock ..... 16-25  
starter/generator  
armature ..... 12-16  
bearing ..... 12-15  
brush spring ..... 12-12  
brushes ..... 12-12  
commutator ..... 12-16  
field coils ..... 12-8, 12-18
- K**
- key switch**  
engine kill circuit testing ..... 11-30  
installation ..... 12-24, 12-26  
removal ..... 12-24  
starter circuit testing ..... 11-15
- kill circuit, engine**  
testing ..... 11-30
- kill wire, engine**  
testing ..... 11-31
- L**
- lockout cam**  
limit switch ..... 11-17  
testing ..... 11-32
- lockout cam circuit**  
function ..... 11-5
- low oil warning light**  
testing ..... 11-32
- M**
- master cylinder**  
installation ..... 6-29  
removal ..... 6-28
- O**
- oil level sensor**  
testing ..... 11-32
- P**
- park brake**  
adjustment ..... 6-35
- pedal, accelerator**  
*see* accelerator
- pedal, brake**  
*see* brakes
- R**
- rack and pinion**  
assembly ..... 7-11  
installation ..... 7-12
- reverse buzzer**  
installation ..... 12-29  
limit switch  
installation ..... 12-30  
removal ..... 12-30  
testing ..... 11-31  
removal ..... 12-29  
testing ..... 11-31
- RPM limiter**  
testing ..... 11-24



**S****safety**

statements ..... 1-1

**serial number, vehicle** ..... 3-1**shock absorber**see suspension, front *and* suspension, rear**solenoid**

testing ..... 11-17

**spark plug**

gap adjustment ..... 13-2

**specifications**

vehicle ..... 2-1

**starter/generator**

armature ..... 12-14

ground test ..... 12-7, 12-17

armature inspection ..... 12-16

assembly ..... 12-3, 12-8, 12-13, 12-18

## bearing

cleaning ..... 12-15

inspection ..... 12-15

removal ..... 12-15

belt tension adjustment ..... 12-9, 12-20

## brush spring

inspection ..... 12-12

replacement ..... 12-12

brushes ..... 12-11

inspection ..... 12-12

replacement ..... 12-12

commutator ..... 12-14

armature replacement ..... 12-16

cleaning ..... 12-16

inspection ..... 12-16

disassembly ..... 12-11, 12-14

## field coil

inspection ..... 12-8, 12-18

removal ..... 12-16

installation ..... 12-9, 12-19

removal ..... 12-1, 12-10

rework ..... 12-18

testing ..... 11-19, 11-22

**steering**

## rack and pinion

assembly ..... 7-11

installation ..... 7-12

**steering column**

assembly ..... 7-4

**steering wheel**

installation ..... 7-3

removal ..... 7-1

**storage**

vehicle storage ..... 3-2

**suspension, front**

## a-arm

installation ..... 7-16

## kingpin and steering spindle

installation ..... 7-15

toe-in adjustment ..... 7-13

**suspension, rear**

## shock absorber

removal and inspection ..... 9-1

## snubber

installation ..... 9-4

**T****test procedure**

battery ..... 11-11, 11-33

diode ..... 11-20

engine kill circuit ..... 11-31

fuel gauge ..... 11-34

fuel level sending unit ..... 11-33

fuse ..... 11-13

ground cables ..... 11-14

headlight ..... 11-40

headlight diode ..... 11-39

headlight switch ..... 11-38

hour meter ..... 11-37

ignition coil ..... 11-24

ignition test ..... 11-23

## key switch

engine kill circuit ..... 11-30

starter circuit ..... 11-15

lockout cam ..... 11-32

lockout cam limit switch ..... 11-17

low oil warning light ..... 11-32

oil level sensor ..... 11-32

reverse buzzer ..... 11-31

reverse buzzer limit switch ..... 11-31

RPM limiter ..... 11-24

solenoid ..... 11-17

starter/generator ..... 11-19, 11-22

voltage regulator ..... 11-22

wire continuity ..... 11-20

**test procedures, index of** ..... 11-10**testing**

circuit testing ..... 11-5

## starter/generator

armature ground test ..... 12-7

ground test ..... 12-17

**tire**

pressure ..... 8-1

**troubleshooting**see *also* testing

brake system ..... 6-3

**tube bumper**  
see bumper, tube

**V**

**voltage regulator**  
testing ..... 11-22

**W**

**WARNING**  
definition of ..... 1-1

**wheel cylinder**  
see brakes, wheel cylinder

**wire continuity testing** ..... 11-20  
**wiring diagram** ..... 11-6













**Club Car, LLC**  
P.O. Box 204658  
Augusta, GA 30917-4658  
USA

**Web** [www.clubcar.com](http://www.clubcar.com)  
**Phone** 1.706.863.3000  
1.800.ClubCar  
**Int'l** +1 706.863.3000  
**Fax** 1.706.863.5808