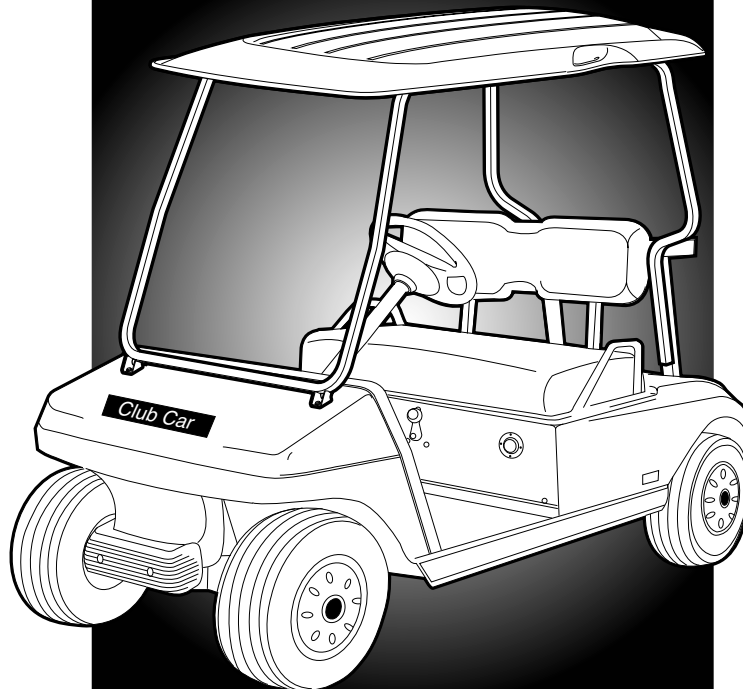


Club Car

®

2005 MAINTENANCE SERVICE SUPPLEMENT



POWERDRIVE SYSTEM 48 ELECTRIC VEHICLES

MANUAL NUMBER 102680407
EDITION CODE 0305A00000

FOREWORD

Club Car vehicles are designed and built to provide the ultimate in performance efficiency; however, proper maintenance and repair are essential for achieving maximum service life and continued safe and reliable operation.

This supplement provides detailed information for the maintenance and repair of PowerDrive System 48 electric vehicles and should be used in conjunction with the appropriate maintenance and service manual.

If you do not have the appropriate maintenance and service manual, you may order one from your local Club Car or Carryall representative. Maintenance and service manuals available include the following:

2005 Turf/Carryall Vehicle Maintenance & Service Manual

Publication Part No. 102680404

2005 Transportation Vehicle Maintenance & Service Manual

Publication Part No. 102680405

This supplement and corresponding maintenance and service manual should be thoroughly reviewed prior to servicing the vehicle. The procedures provided must be properly implemented, and the DANGER, WARNING, and CAUTION statements must be heeded.

This supplement was written for the trained technician who already has knowledge and skills in electrical and mechanical repair. If the technician does not have such knowledge and skills, attempted service or repairs to the vehicle may render the vehicle unsafe. For this reason, Club Car advises that all repairs and/or service be performed by an authorized Club Car or Carryall distributor/dealer representative or by a Club Car factory-trained technician.

It is the policy of Club Car, Inc. to assist its distributors and dealers in continually updating their service knowledge and facilities so they can provide prompt and efficient service for vehicle owners. Regional technical representatives, vehicle service seminars, periodic service bulletins, maintenance and service manuals, and other service publications also represent Club Car's continuing commitment to customer support.

This service supplement, used in conjunction with the appropriate maintenance and service manual, covers all aspects of typical vehicle service; however, unique situations do sometimes occur when servicing a vehicle. If it appears that a service question is not answered in this supplement, you may write to us at: Club Car, Inc., P.O. Box 204658, Augusta, Georgia 30917-4658, USA, Attention: Technical Services, or contact a Club Car Technical Service Representative at (706) 863-3000, ext. 3580.

This supplement does not contain maintenance and service procedures for the battery charger. Contact your local Club Car representative for information on how to obtain the appropriate battery charger maintenance and service manual.

Copyright © 2005 Club Car, Inc.
Club Car, Carryall, and PowerDrive
are registered trademarks of Club Car, Inc.
This manual effective August 2, 2004.

WARNING

- **Read Section 1 – Safety in the appropriate maintenance and service manual before attempting any service on the vehicle.**
- **Before servicing vehicle, read complete section(s) and any referenced information that may be relevant to the service or repair to be performed.**

NOTE: *This manual represents the most current information at the time of publication. Club Car, Inc. is continually working to further improve its vehicles and other products. These improvements may affect servicing procedures. Any modification and/or significant change in specifications or procedures will be forwarded to all Club Car distributors/dealers and will, when applicable, appear in future editions of this manual.*

Club Car, Inc. reserves the right to change specifications and designs at any time without notice and without the obligation of making changes to units previously sold.

There are no warranties expressed or implied in this supplement. See the limited warranty found in the vehicle owner's manual or write to: Club Car, Inc., P.O. Box 204658, Augusta, Georgia 30917-4658, USA, Attention: Warranty Administration.

CONTENTS

SECTION 10 – PERIODIC MAINTENANCE

General Warning	10-1
General Information	10-3
Periodic Service Schedule	10-3
Periodic Lubrication Schedule	10-5

SECTION 11 – ELECTRICAL SYSTEM AND TESTING

General Information	11-1
Wiring Diagrams	11-2
Troubleshooting Guide	11-12
Test Procedures	11-15
Index of Test Procedures	11-15
Communication Display Module (CDM)	11-45
Using the CDM to Retrieve Data from the Onboard Computer	11-47
CDM Troubleshooting Guide	11-47

SECTION 12 – ELECTRICAL COMPONENTS

Key Switch	12-1
Battery Condition Indicator	12-3
Forward/Reverse Switch	12-3
Forward/Reverse Limit Switches	12-5
Half-Speed Resistor – to Half-Speed Reverse Limit Switch	12-6
Reverse Buzzer	12-7
Solenoid	12-8
Diode – Solenoid	12-9
Resistor – Solenoid	12-10
Onboard Computer (OBC)	12-11
Solid State Speed Controller	12-13
Charger Receptacle	12-13
Receptacle Fuse Link	12-15
Motor Controller Output Regulator (MCOR)	12-15
Voltage Limiter	12-17
Brake Pedal Limit Switch	12-18
Park Brake Pedal Limit Switch	12-19
Brake Light Relay	12-20
Light Switch	12-21

Battery Warning Light	12-22
Horn	12-23
Horn Switch	12-24
Hour Meter	12-24

SECTION 13 – BATTERIES

General Information	13-1
Battery Replacement	13-1
Battery Care	13-2
Preventive Maintenance	13-2
Self-Discharge	13-3
Electrolyte Level	13-3
Mineral Content	13-4
Vibration Damage	13-4
Battery Charging	13-4
Charger Shuts Off After 16 Hours	13-4
Deep-Discharge	13-5
Early Excessive Discharging	13-5
Incoming AC Service	13-5
Fleet Rotation	13-5
Numbering Vehicles and Chargers	13-5
Battery Troubleshooting Chart	13-6
Battery Testing	13-7
Battery Charger Test	13-7
On-Charge Voltage Test	13-7
Hydrometer Test	13-7
Discharge Test	13-9
Battery Troubleshooting Examples	13-11
Battery Storage	13-12
Charging a Battery Pack that has Low Voltage	13-12

SECTION 14 – POWERDRIVE BATTERY CHARGER

Refer to the appropriate battery charger maintenance and service manual.

SECTION 15 – MOTOR

General Information	15-1
External Motor Testing	15-1
Motor	15-2

Motor Component Testing and Inspection	15-5
Armature	15-5
Field Windings Inspection	15-6
Motor Components	15-6
Bearing Inspection	15-8
Bearing Removal	15-8
Bearing Installation	15-8
Reconditioning the Motor	15-9
Motor Assembly	15-10
Motor Installation	15-11

SECTION 16 – TRANSAXLE (TYPE G)

Lubrication	16-1
Axle Bearing and Shaft	16-1
Axle Shaft	16-1
Axle Bearing	16-4
Transaxle	16-5
Transaxle Removal	16-5
Transaxle Disassembly, Inspection, and Assembly	16-7
Transaxle Disassembly and Inspection	16-7
Transaxle Assembly	16-9
Transaxle Installation	16-10

SECTION i – INDEX

SECTION 10 – PERIODIC MAINTENANCE

GENERAL WARNING

The following safety statements must be heeded whenever the vehicle is being operated, repaired, or serviced. Service technicians should become familiar with these general safety statements, which can be found throughout this manual. Also, other specific safety statements appear throughout this manual and on the vehicle.

DANGER

- **Battery – Explosive gases! Do not smoke. Keep sparks and flames away from the vehicle and service area. Ventilate when charging or operating vehicle in an enclosed area. Wear a full face shield and rubber gloves when working on or near batteries.**
- **Battery – Poison! Contains acid! Causes severe burns. Avoid contact with skin, eyes, or clothing. Antidotes:**
 - **External: Flush with water. Call a physician immediately.**
 - **Internal: Drink large quantities of milk or water. Follow with milk of magnesia or vegetable oil. Call a physician immediately.**
 - **Eyes: Flush with water for 15 minutes. Call a physician immediately.**

WARNING

- **Follow the procedures exactly as stated in this manual, and heed all DANGER, WARNING, and CAUTION statements in this manual as well as those on the vehicle and battery charger.**
- **Only trained technicians should service or repair the vehicle or battery charger. Anyone doing even simple repairs or service should have knowledge and experience in electrical and mechanical repair. The appropriate instructions must be used when performing maintenance, service, or accessory installation.**
- **Prior to servicing the vehicle or leaving the vehicle unattended, turn the key switch OFF, remove the key, and place the Forward/Reverse handle in the NEUTRAL position. Chock the wheels when servicing the vehicle.**
- **To avoid unintentionally starting the vehicle, disconnect the batteries as shown (Figure 10-1, Page 10-2).**
- **After disconnecting the batteries, discharge the controller capacitors as follows:**
 - **Turn key switch to ON and place the Forward/Reverse handle in REVERSE.**
 - **Slowly press the accelerator pedal and keep it pressed until the reverse warning buzzer can no longer be heard. When the buzzer stops sounding, the controller capacitors are discharged.**
- **Wear safety glasses or approved eye protection when servicing the vehicle or battery charger. Wear a full face shield and rubber gloves when working on or near batteries.**
- **Do not wear loose clothing or jewelry such as rings, watches, chains, etc., when servicing the vehicle or battery charger.**

WARNING CONTINUED ON NEXT PAGE...

⚠ WARNING

- **Moving parts! Do not attempt to service the vehicle while it is running.**
- **Hot! Do not attempt to service hot motor. Failure to heed this warning could result in severe burns.**
- **Use insulated tools when working near batteries or electrical connections. Use extreme caution to avoid shorting of components or wiring.**
- **Check the vehicle owner's manual for proper location of all vehicle safety and operation decals and make sure they are in place and are easy to read.**
- **Any modification or change to the vehicle that affects the stability or handling of the vehicle, or increases maximum vehicle speed beyond factory specifications, could result in severe personal injury or death.**
- **Lift only one end of the vehicle at a time. Use a suitable lifting device (chain hoist or hydraulic floor jack) with 1000 lb. (454 kg) minimum lifting capacity. Do not use lifting device to hold vehicle in raised position. Use approved jack stands of proper weight capacity to support the vehicle and chock the wheels that remain on the floor. When not performing a test or service procedure that requires movement of the wheels, lock the brakes.**
- **If wires are removed or replaced, make sure wiring and wire harness are properly routed and secured. Failure to properly route and secure wiring could result in vehicle malfunction, property damage, personal injury, or death.**
- **For vehicles with cargo beds, remove all cargo before raising the bed or servicing the vehicle. If the vehicle is equipped with a prop rod, ensure that it is securely engaged while bed is raised. Do not close bed until all persons are clear of cargo bed area. Keep hands clear of all crush areas. Do not drop cargo bed; lower gently and keep entire body clear. Failure to heed this warning could result in severe personal injury or death.**
- **Improper use of the vehicle or failure to properly maintain it could result in decreased vehicle performance, severe personal injury, or death.**
- **Do not leave children unattended on vehicle.**

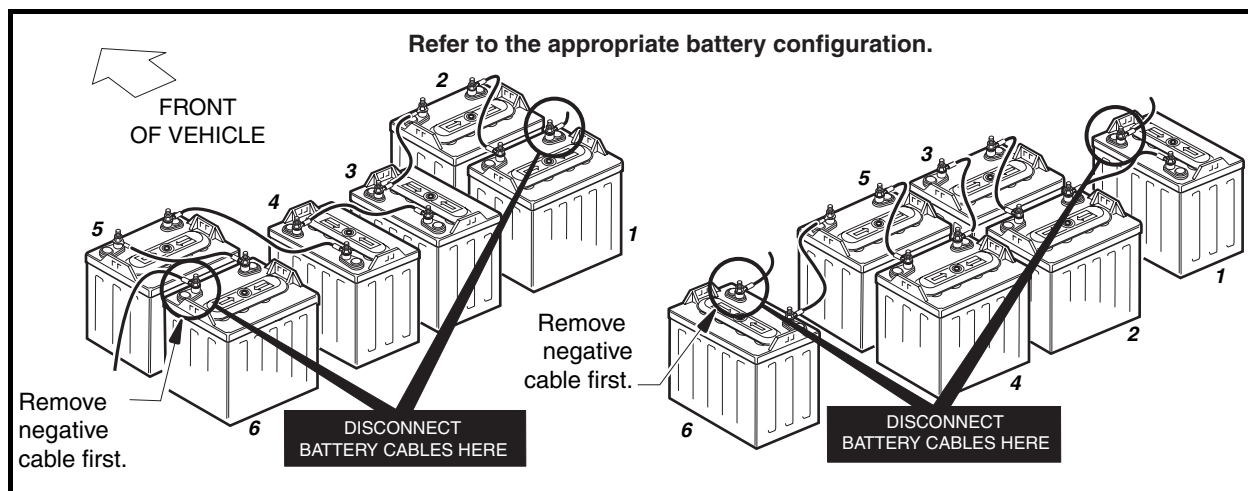


Figure 10-1 Battery Configuration

GENERAL INFORMATION

See General Warning on page 10-1.

To ensure trouble-free vehicle performance, it is very important to follow an established preventive maintenance program. Regular and consistent vehicle maintenance can prevent vehicle downtime and expensive repairs that can result from neglect. Any vehicle not functioning correctly should be removed from use until it is properly repaired. This will prevent further damage to the vehicle and avoid the possibility of injury due to unsafe conditions.

Contact your local Club Car distributor/dealer to perform all repairs and semiannual and annual periodic service.

PERIODIC SERVICE SCHEDULE

⚠ WARNING

- **Service, repairs, and adjustments must be made per instructions in the appropriate maintenance and service manual and this supplement.**

NOTE: *If the vehicle is constantly subjected to heavy use or severe operating conditions, the preventive maintenance procedures should be performed more often than recommended in the periodic service and lubrication schedules.*

Both the Periodic Service Schedule and the Periodic Lubrication Schedule must be followed to keep the vehicle in optimum operating condition.

PERIODIC SERVICE SCHEDULE		
REGULAR INTERVAL	SERVICE	
Daily service by owner	Batteries	Charge batteries (after each use only).
Weekly service by owner	Batteries	Check electrolyte level. Add water if necessary. See Section 13 – Batteries.
Monthly service by owner or trained technician	Batteries	Wash battery tops and clean terminals with baking soda/water solution. Dispose of waste water properly.
	Tires	Check air pressure and adjust if necessary. See Section 2 – Specifications in the appropriate maintenance and service manual.
	General vehicle	Wash battery compartment and underside of vehicle.
Periodic Service Schedule continued on next page...		

PERIODIC SERVICE SCHEDULE		
REGULAR INTERVAL	SERVICE	
Semiannual service by trained technician only (or every 50 hours of operation, whichever comes first)	Brake system	Check brake shoes; replace if necessary. See Section 6 – Wheel Brake Assemblies in the appropriate maintenance and service manual.
		Lubricate brake slides. See Periodic Lubrication Schedule on page 10-5. See also Section 6 – Wheel Brake Assemblies in the appropriate maintenance and service manual.
		Check brake cables for damage; replace if necessary.
	Electrical wiring and connections	Check for tightness and damage.
	Forward/Reverse switch	Check condition of contacts and wire connections; make sure connections are tight.
	Front wheel alignment and camber	Check and adjust if required. See Section 7 – Steering and Front Suspension in the appropriate maintenance and service manual.
	Motor Controller Output Regulator (MCO _R)	Check for loose hardware, cracks, or other damage.
Annual service by trained technician only (or every 100 hours of operation, whichever comes first)	Batteries	If batteries are not performing as expected, refer to Section 13 – Batteries.

WARNING

- If any problems are found during scheduled inspection or service, do not operate the vehicle until repairs are made. Failure to make necessary repairs could result in fire, property damage, severe personal injury, or death.

PERIODIC LUBRICATION SCHEDULE

PERIODIC LUBRICATION SCHEDULE			
REGULAR INTERVAL	SERVICE	LUBRICATION POINTS	RECOMMENDED LUBRICANT
Semiannually by owner or trained technician (every 50 hours of operation or 100 rounds of golf)	Brake pedal shaft bearings	1	Dry Moly Lube (CCI P/N 1012151)
	Brake linkage and pivots	2	Dry Moly Lube (CCI P/N 1012151)
	Accelerator pivot rod supports	3	Dry Moly Lube (CCI P/N 1012151)
	Charger receptacle (vehicles with charger receptacles only) and Forward/Reverse switch contacts	4	WD 40
	Brake slides	5	Dry Moly Lube (CCI P/N 1012151)
	Front suspension (5 fittings)	6	Chassis Lube (EP NLGI Grade 2)
Annually by trained technician only (every 100 hours of operation or 200 rounds of golf)	Check/fill transaxle to plug level	7	22 oz. (0.67 liter) SAE 30 WT. API, class SE, SI, or SG oil (or higher)
	Inspect front wheel bearings (Repack as necessary) (Four-wheel brake vehicles only)	8	Chassis Lube – EP NLGI Grade 2

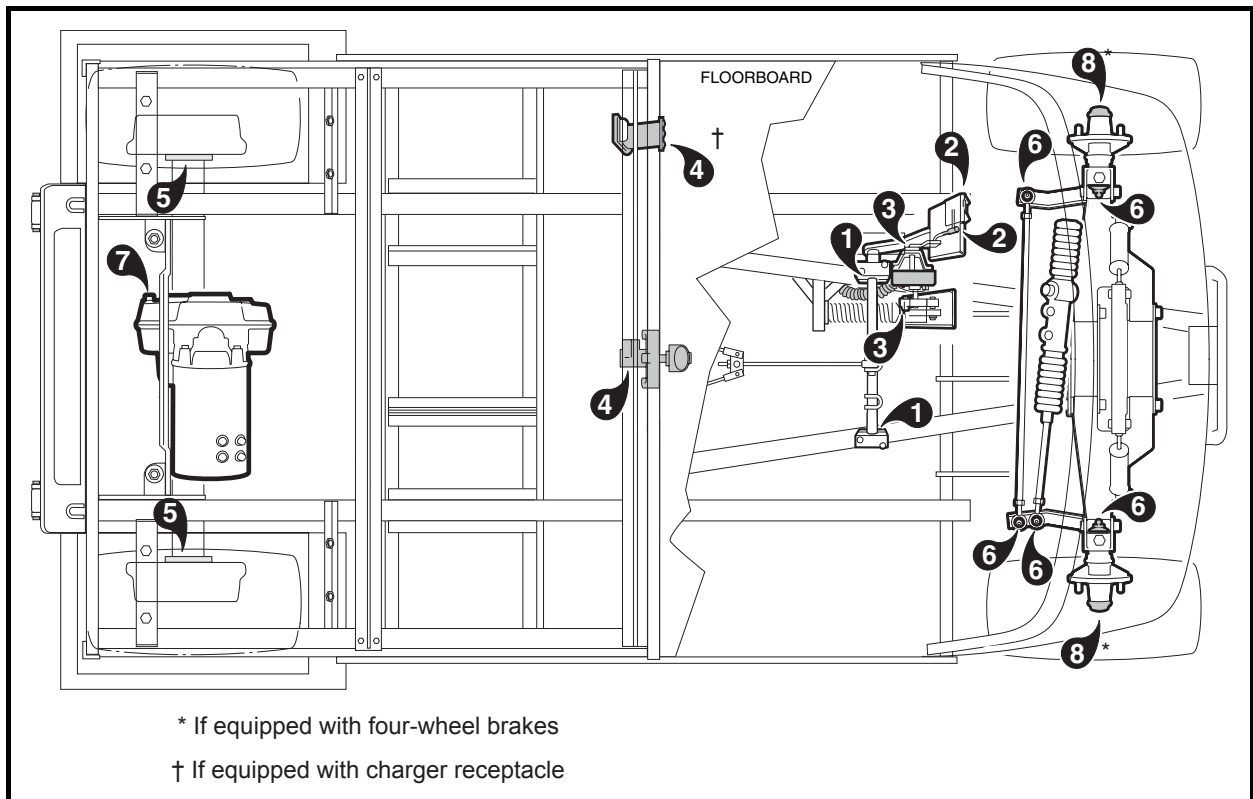


Figure 10-2 Vehicle Lubrication Points

SECTION 11 – ELECTRICAL SYSTEM AND TESTING

⚠ DANGER

- See General Warning, Section 10, Page 10-1.

⚠ WARNING

- See General Warning, Section 10, Page 10-1.

GENERAL INFORMATION

The PowerDrive System 48 vehicle uses a 48-volt electrical system that is powered by six 8-volt lead-acid batteries and includes an onboard computer. The PowerDrive System 48 vehicle uses a solid state speed controller which increases or decreases the current (amperage) through the armature and field coils of a series-wound motor.

WIRING DIAGRAMS

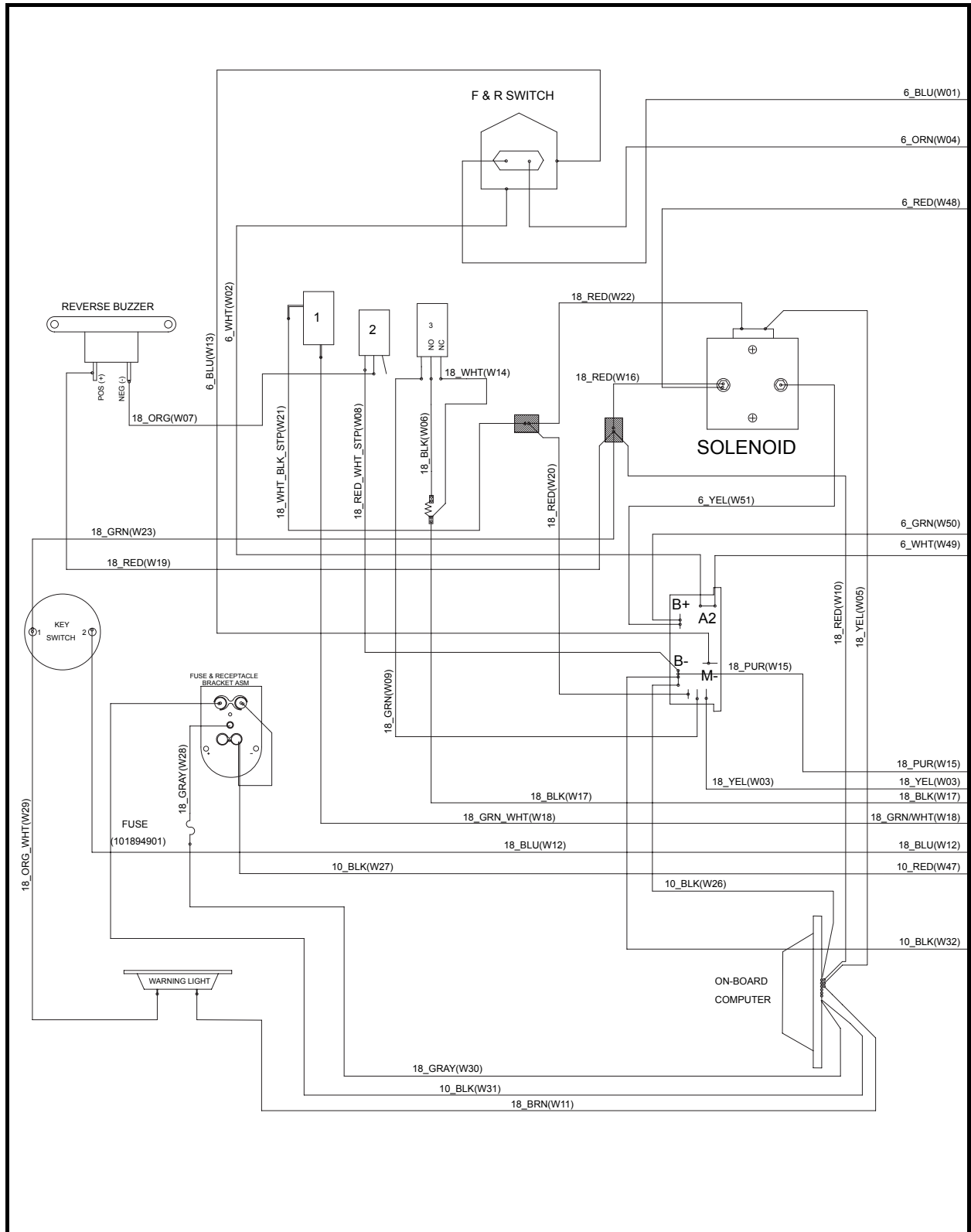


Figure 11-1 Wiring Diagram – Turf 1/Carryall 1 Electric Vehicle

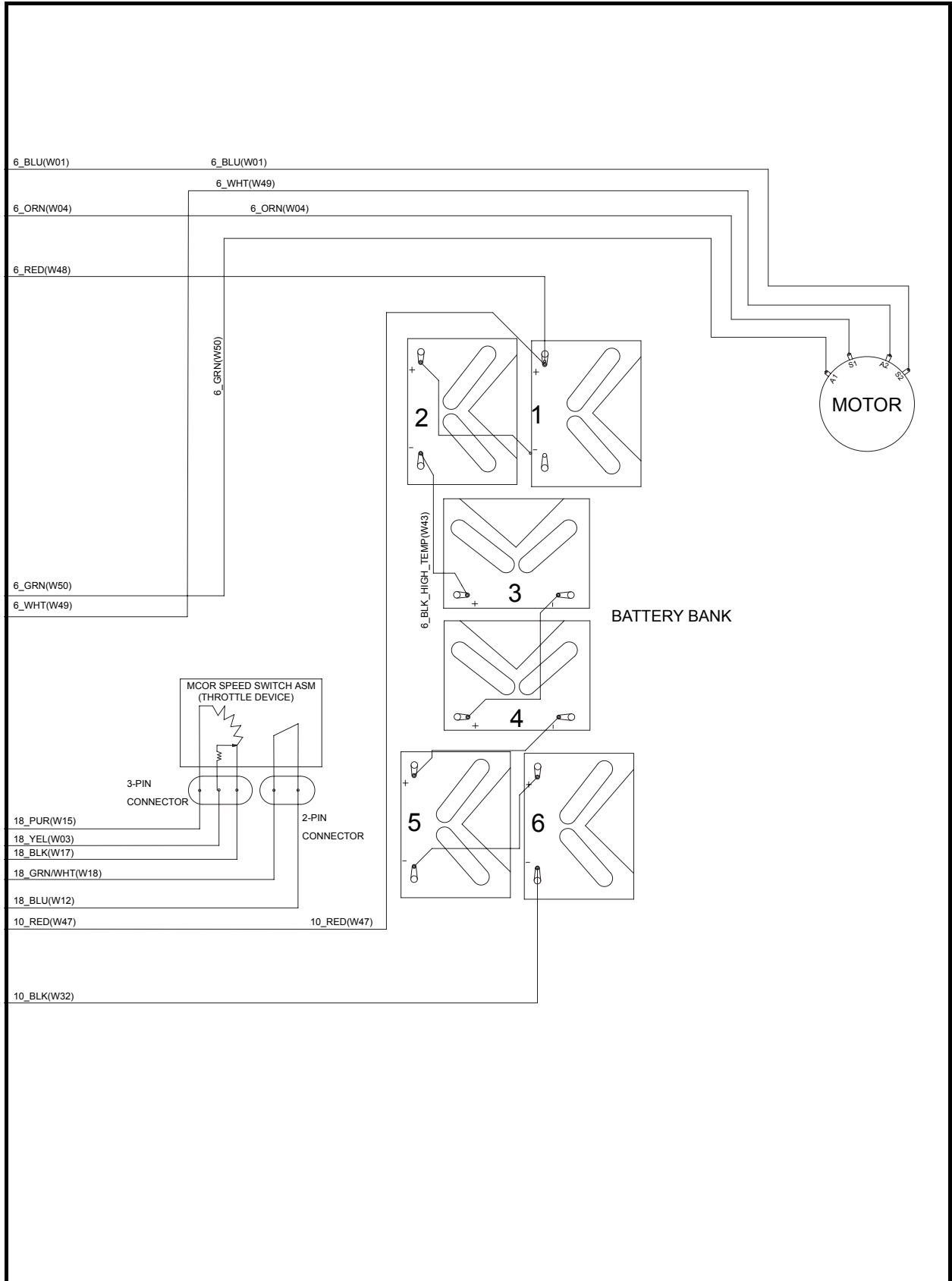


Figure 11-2 Wiring Diagram – Turf 1/Carryall 1 Electric Vehicle

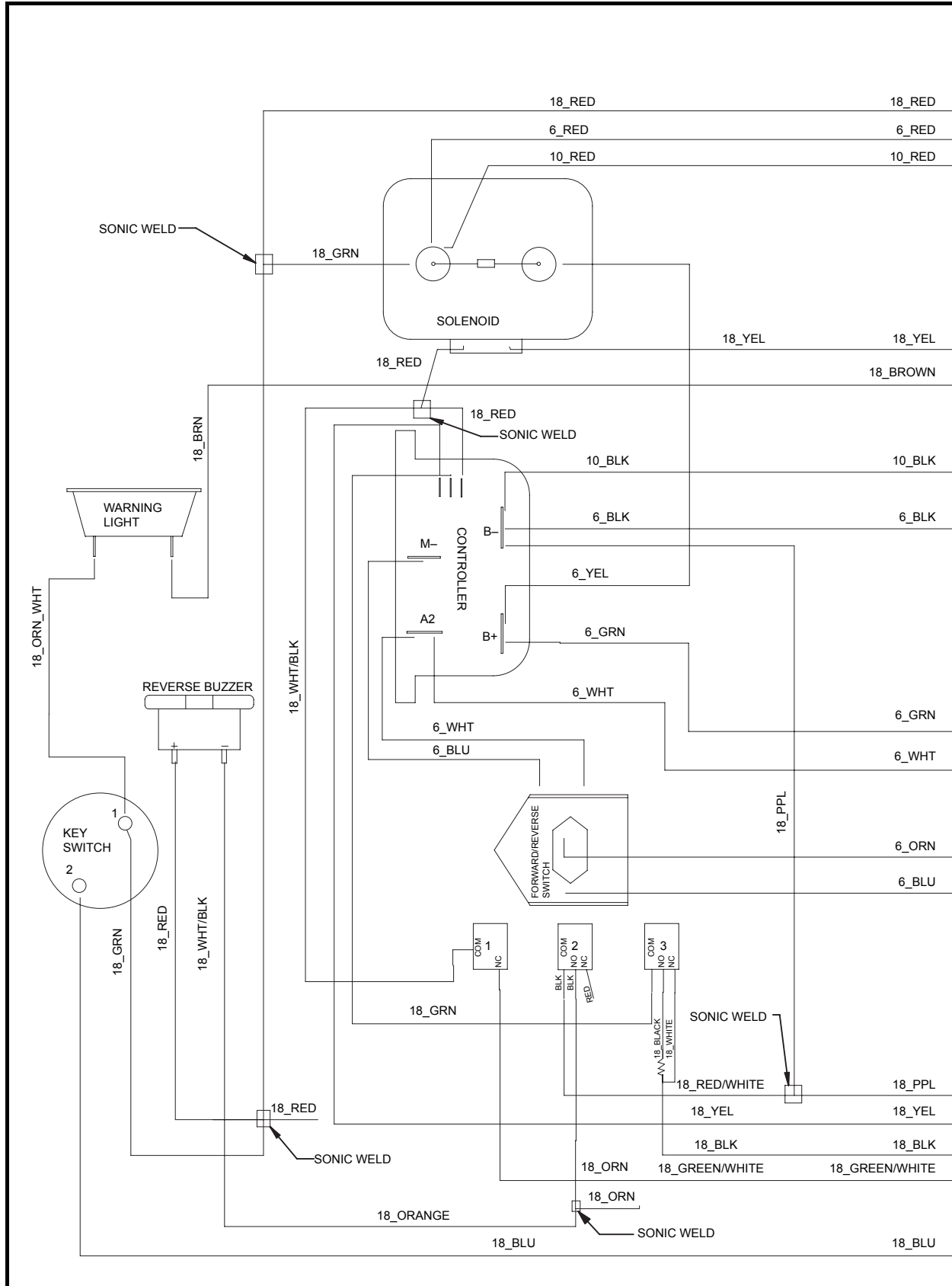


Figure 11-3 Wiring Diagram – Turf 2/Carryall 2 Electric Vehicle

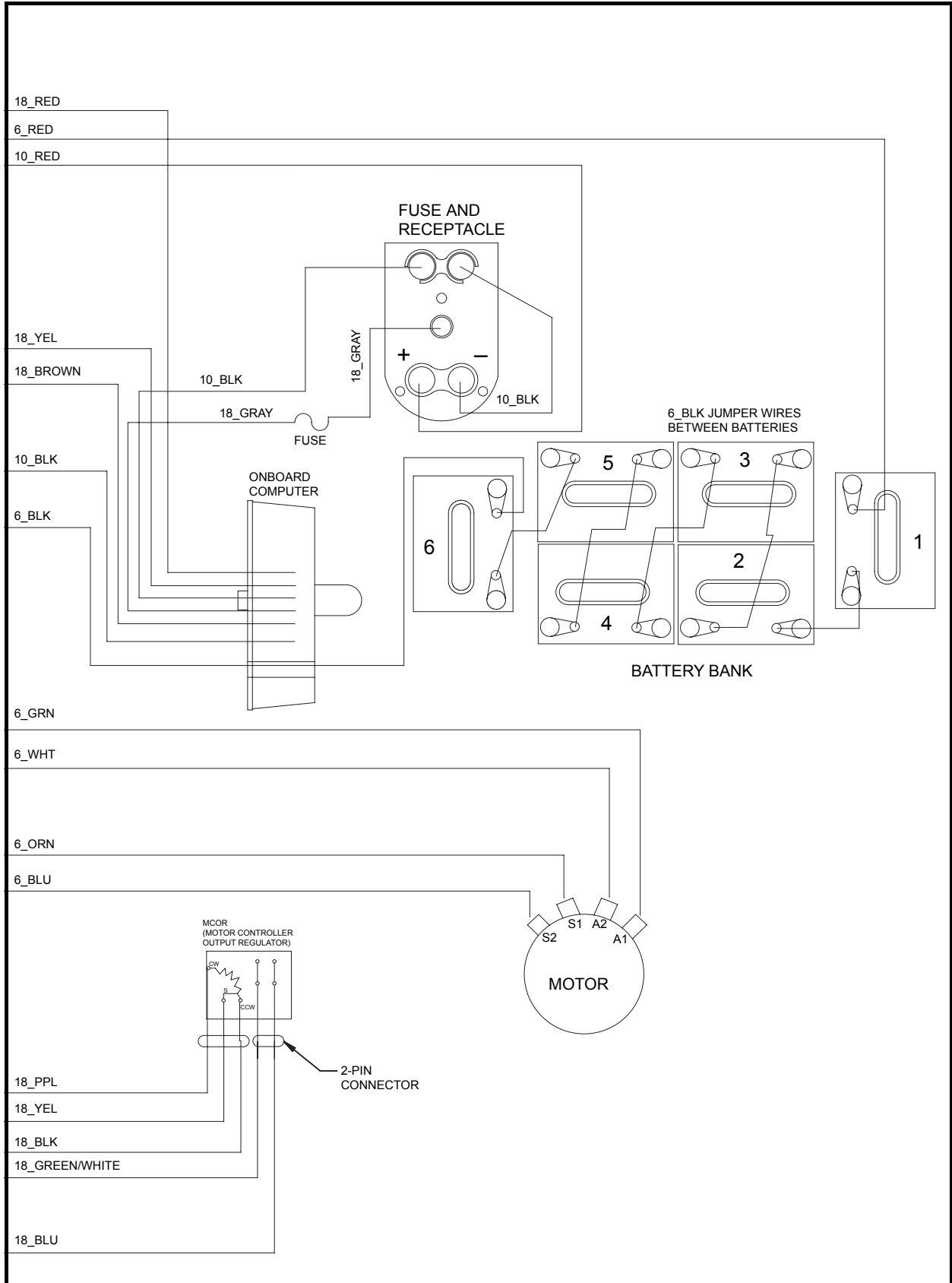


Figure 11-4 Wiring Diagram – Turf 2/Carryall 2 Electric Vehicles

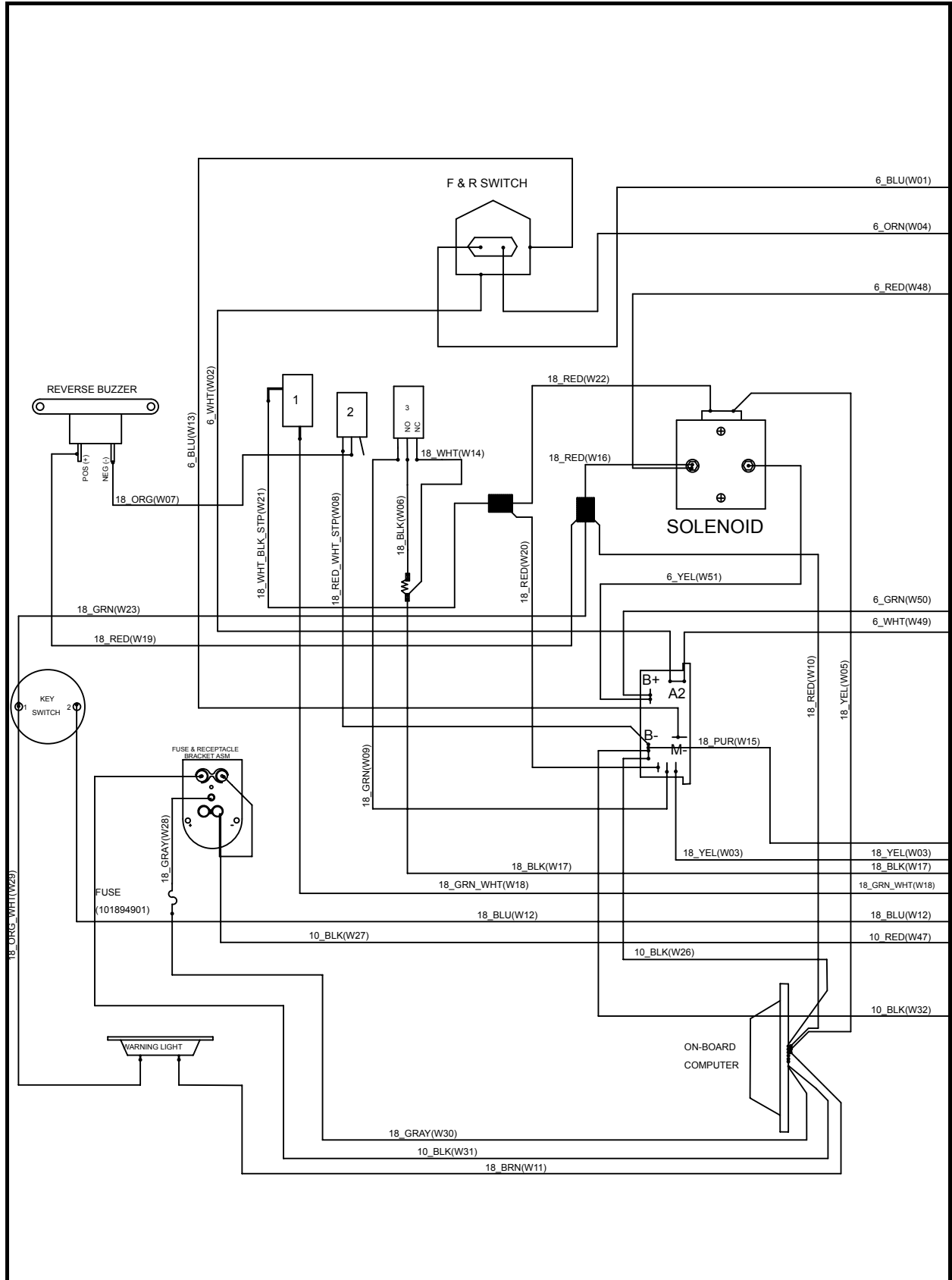


Figure 11-5 Wiring Diagram – Carryall 6 and TransPorter Electric Vehicles

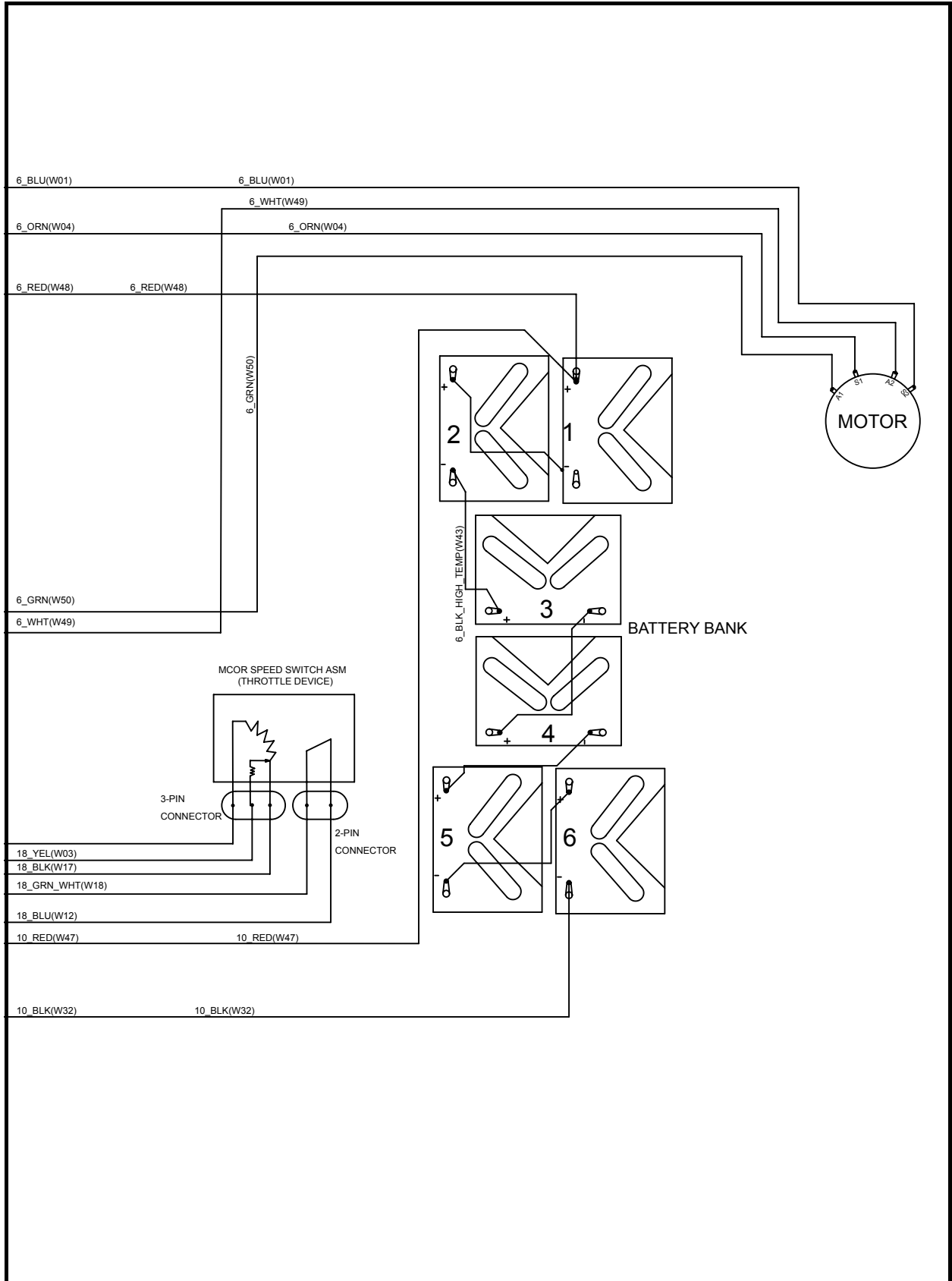


Figure 11-6 Wiring Diagram – Carryall 6 and TransPorter Electric Vehicles

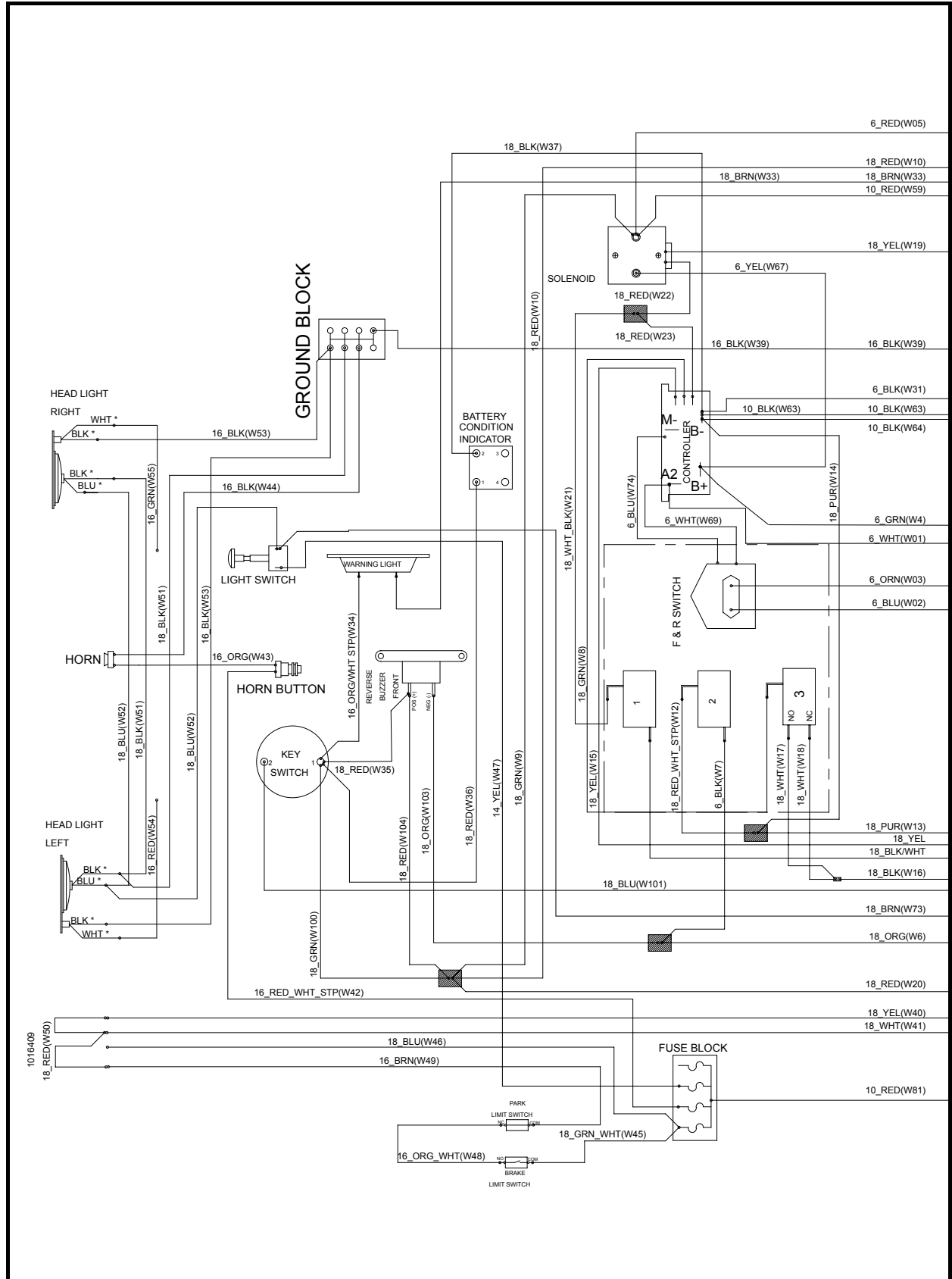


Figure 11-7 Wiring Diagram – Villager 6 Electric Vehicles

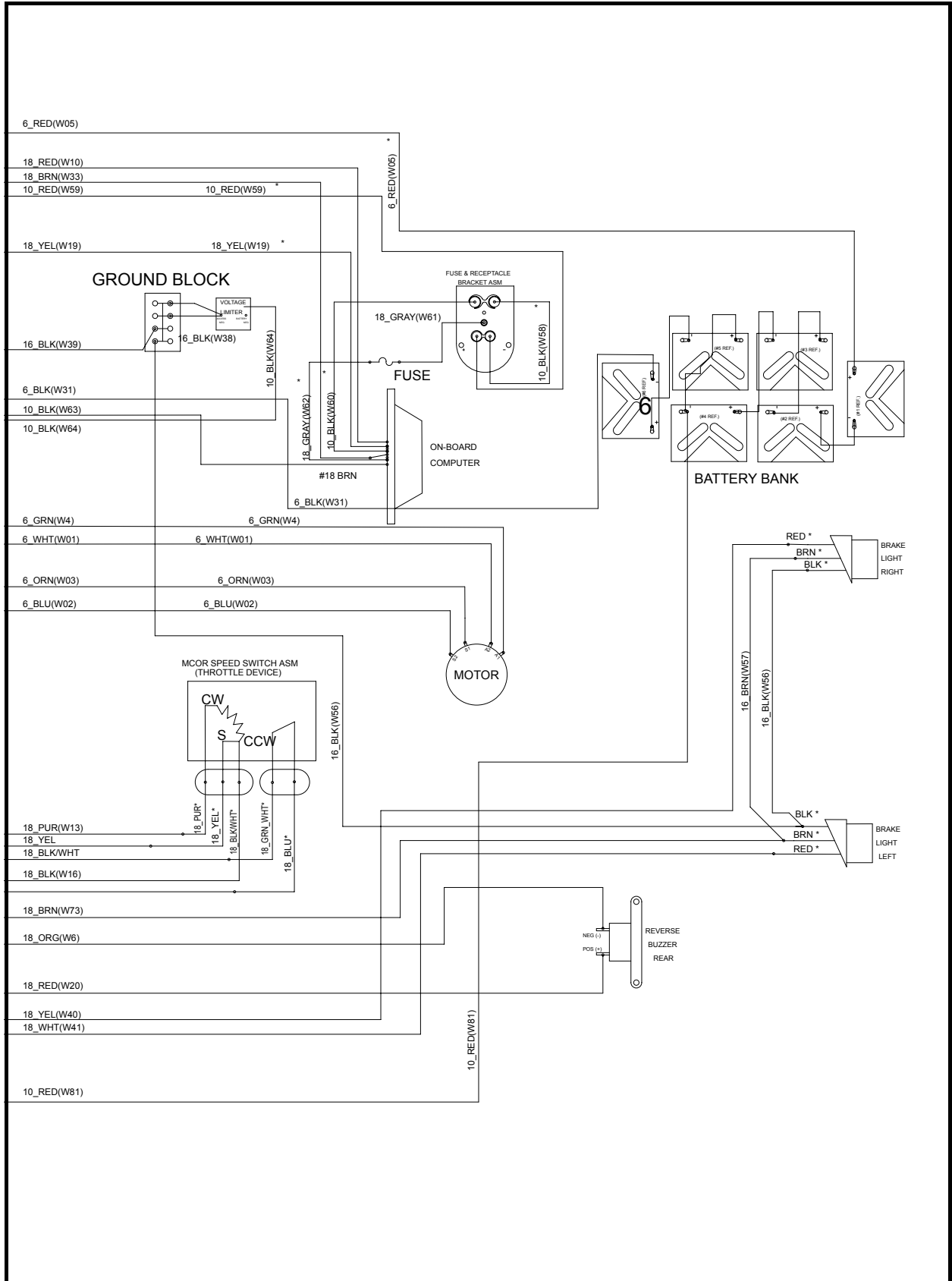


Figure 11-8 Wiring Diagram – Villager 6 Electric Vehicles

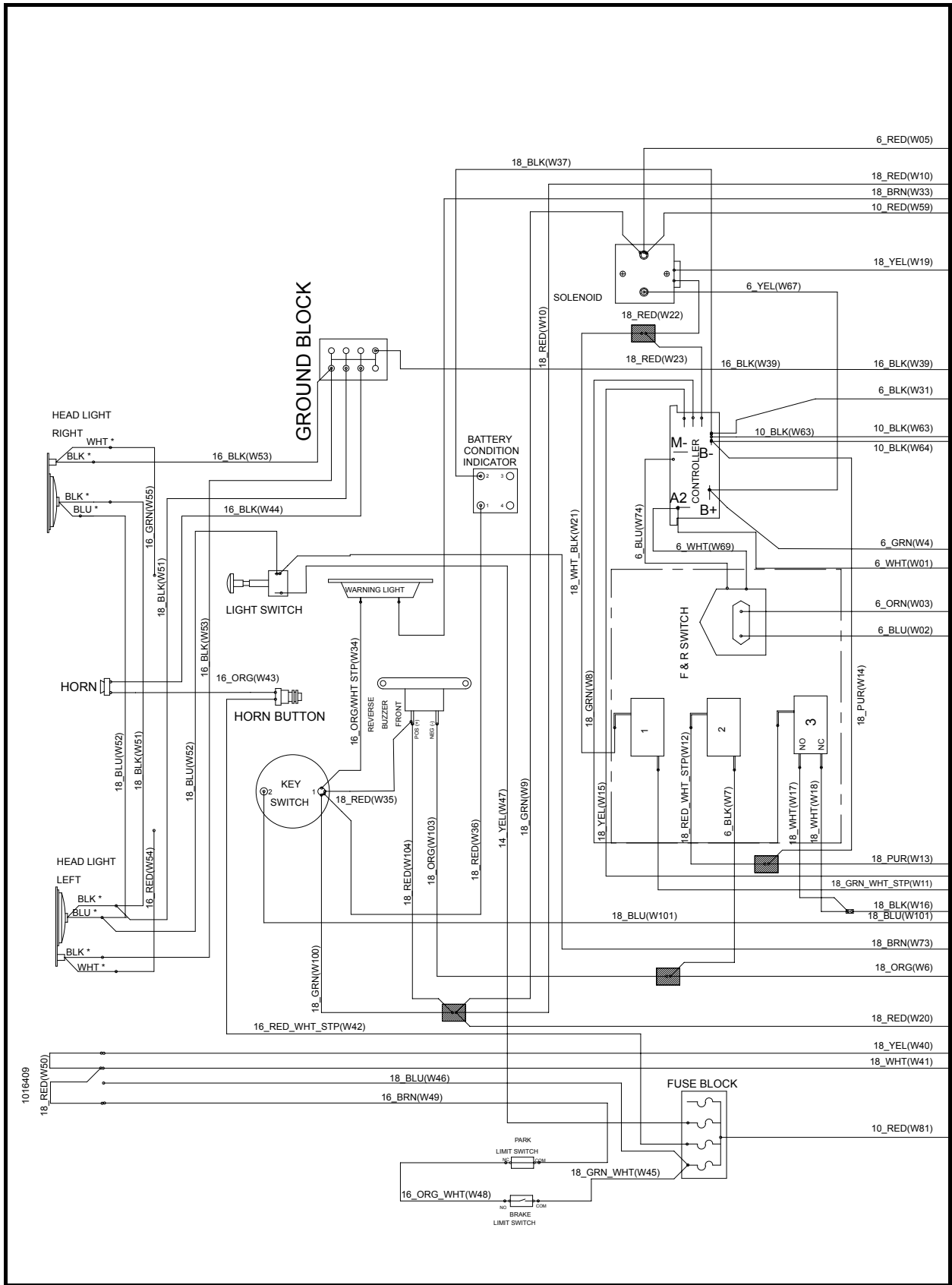


Figure 11-9 Wiring Diagram – Villager 8 Electric Vehicles

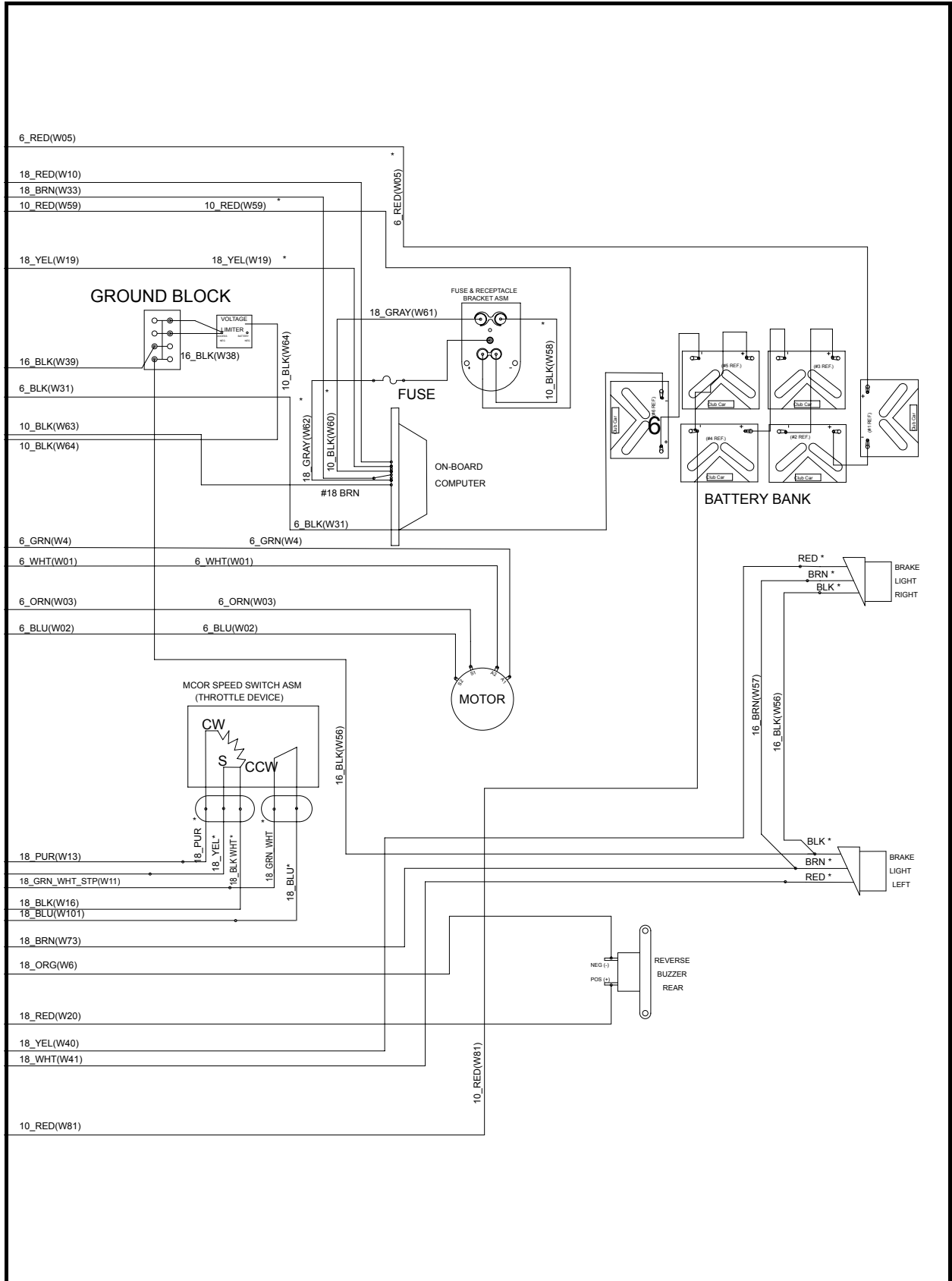


Figure 11-10 Wiring Diagram – Villager 8 Electric Vehicles

TROUBLESHOOTING GUIDE

TROUBLESHOOTING GUIDE		
SYMPTOM	POSSIBLE CAUSES	CORRECTIVE ACTION
Vehicle will not operate – no solenoid click	Improper or poor battery connections	Test Procedure 1 – Batteries / Voltage Check on page 11-16
	Batteries discharged	Test Procedure 1 – Batteries / Voltage Check on page 11-16
	Key switch – Loose wires	Test Procedure 2 – Key Switch on page 11-16
	Key switch – Failed switch	Test Procedure 2 – Key Switch on page 11-16
	Forward/Reverse Anti-arcing limit switch – Loose wires	Test Procedure 3 – Forward/Reverse Anti-Arcing Limit Switch on page 11-17
	Forward/Reverse Anti-arcing limit switch – Failed switch	Test Procedure 3 – Forward/Reverse Anti-Arcing Limit Switch on page 11-17
	Forward/Reverse Anti-arcing limit switch – Cam is not activating switch	See Section 12 – Electrical Components
	Accelerator pedal limit switch – Loose wire	Test Procedure 7 – Motor Controller Output Regulator (MCO) on page 11-21
	Accelerator pedal limit switch – Failed switch	Test Procedure 7 – Motor Controller Output Regulator (MCO) on page 11-21
	Accelerator pedal limit switch – Disconnected or improperly connected wires	See Wiring Diagrams beginning on page 11-2
	Solenoid – Loose wires	Test Procedure 4 – Solenoid Activating Coil and Diode on page 11-18
	Solenoid – Failed coil	Test Procedure 4 – Solenoid Activating Coil and Diode on page 11-18
	Solenoid – Failed solenoid diode	Test Procedure 4 – Solenoid Activating Coil and Diode on page 11-18
	Controller electrical leakage – Dirt or acid residue on the controller	Test Procedure 8 – Solid State Speed Controller on page 11-24
	Onboard computer – Battery connections	See Wiring Diagrams beginning on page 11-2
Onboard computer – Onboard computer solenoid lockout failure	Test Procedure 9 – Onboard Computer Lockout Circuit on page 11-26	
Vehicle will not operate – solenoid clicks	Improper or poor battery connections	Test Procedure 1 – Batteries / Voltage Check on page 11-16
	Batteries discharged	Test Procedure 1 – Batteries / Voltage Check on page 11-16
	Solenoid – Loose wires	Test Procedure 4 – Solenoid Activating Coil and Diode on page 11-18
	Solenoid – Failed contacts	Test Procedure 6 – Solenoid Contacts (Power Off) and Resistor on page 11-20
	Forward/Reverse switch – Loose wires	Test Procedure 5 – Forward/Reverse Switch on page 11-19
Troubleshooting Guide continued on next page...		

TROUBLESHOOTING GUIDE		
SYMPTOM	POSSIBLE CAUSES	CORRECTIVE ACTION
Vehicle will not operate – solenoid clicks, continued	Forward/Reverse switch – Failed contacts	Test Procedure 5 – Forward/Reverse Switch on page 11-19
	MCOR – Loose wires	See Wiring Diagrams beginning on page 11-2
	MCOR – Improperly wired	See Wiring Diagrams beginning on page 11-2
	MCOR – Short or open circuit	Test Procedure 7B – MCOR Voltage on page 11-22
	Controller – Loose wires	Test Procedure 8 – Solid State Speed Controller on page 11-24
	Controller – Failed speed controller	Test Procedure 8 – Solid State Speed Controller on page 11-24
	Motor – Loose wires	See Section 15 – Motor
	Motor – Open/shorted windings	See Section 15 – Motor
Vehicle runs slowly	Wiring – Improperly wired	See Wiring Diagrams beginning on page 11-2
	Improper or poor battery connections	Test Procedure 1 – Batteries / Voltage Check on page 11-16 and Section 13 – Batteries
	Improper or poor battery connections	See Wiring Diagrams beginning on page 11-2
	Batteries failed	Test Procedure 1 – Batteries / Voltage Check on page 11-16 and Section 13 – Batteries
	Batteries not fully charged	Test Procedure 1 – Batteries / Voltage Check on page 11-16 and Section 13 – Batteries
	Motor – Loose wires	See Section 15 – Motor
	Motor – Failed motor	See Section 15 – Motor
	Half-speed reverse limit switch – Failed in the closed position	Test Procedure 12 – Half-Speed Reverse Limit Switch (Limit Switch No. 3) on page 11-27
	Half-speed reverse limit switch – Improperly wired	See Wiring Diagrams beginning on page 11-2
	Controller – Vehicle overload	Let controller cool, remove part of load
	Controller – Failed speed controller	Test Procedure 8 – Solid State Speed Controller on page 11-24
	Brakes – Dragging brakes	See Section 6 – Wheel Brake Assemblies in the appropriate maintenance and service manual.
	Tires – Under-inflated or flat tires	See Section 8 – Wheel and Tires in the appropriate maintenance and service manual
Troubleshooting Guide continued on next page...		

TROUBLESHOOTING GUIDE		
SYMPTOM	POSSIBLE CAUSES	CORRECTIVE ACTION
Vehicle runs full speed in reverse	Forward/Reverse half-speed reverse limit switch – Loose or disconnected wires	See Section 12 – Electrical Components
	Forward/Reverse half-speed reverse limit switch – Failed switch	See Section 12 – Electrical Components
	Half speed (5100-ohm) resistor – Resistor is disconnected or has failed	Test Procedure 13 – Half-Speed Reverse Resistor on page 11-28
Vehicle will run in forward but not in reverse, or will run in reverse but not in forward	Forward/Reverse anti-arcing limit switch – Loose or broken wires	Test Procedure 3 – Forward/Reverse Anti-Arcing Limit Switch on page 11-17 and Section 12 – Electrical Components
	Forward/Reverse anti-arcing limit switch – Improper actuation of switch	Test Procedure 3 – Forward/Reverse Anti-Arcing Limit Switch on page 11-17 and Section 12 – Electrical Components
	Forward/Reverse anti-arcing limit switch – Improperly wired	Test Procedure 3 – Forward/Reverse Anti-Arcing Limit Switch on page 11-17 and Section 12 – Electrical Components
	Forward/Reverse switch – Poor continuity of switch contacts	Test Procedure 5 – Forward/Reverse Switch on page 11-19
Vehicle not being fully charged	Charger connections – Loose wires at receptacle or batteries	See Section 14 – PowerDrive Battery Charger
	Charger – Incorrect incoming AC voltage	See Section 14 – PowerDrive Battery Charger
	Battery charger output is low	See Section 14 – PowerDrive Battery Charger
	Battery charger cord and plugs	See Section 14 – PowerDrive Battery Charger
	Battery charger relay	See Section 14 – PowerDrive Battery Charger
	Battery charger fuse is blown	See Section 14 – PowerDrive Battery Charger
	Charger/Onboard computer – Improper charging	See Section 14 – PowerDrive Battery Charger
Vehicle runs without pressing accelerator when key switch is ON and the Forward/Reverse handle is in FORWARD or REVERSE	Accelerator – Improper pedal adjustment	See Section 5 – Accelerator and Brake Pedal Group in the appropriate maintenance and service manual

TEST PROCEDURES

Using the following procedures, the entire PowerDrive electrical system can be tested without major disassembly of the vehicle. **See following WARNING.**

WARNING

- **If wires are removed or replaced, make sure wiring and wire harness are properly routed and secured. Failure to properly route and secure wiring could result in vehicle malfunction, property damage, personal injury, or death.**

INDEX OF TEST PROCEDURES

1. Batteries / Voltage Check
2. Key Switch
3. Forward/Reverse Anti-Arcing Limit Switch
4. Solenoid Activating Coil and Diode
5. Forward/Reverse Switch
6. Solenoid Contacts (Power Off) and Resistor
7. Motor Controller Output Regulator (MCOR)
8. Solid State Speed Controller
9. Onboard Computer Lockout Circuit
10. Battery Warning Light
11. Voltage at Charger Receptacle Red Wire Socket
12. Half-Speed Reverse Limit Switch (Limit Switch No. 3)
13. Half-Speed Reverse Resistor
14. Reverse Buzzer Limit Switch
15. Reverse Buzzer
16. Wire Continuity
17. Battery Voltage Supply (Only for Vehicles with Headlights)
18. Light Switch
19. Brake Light Relay
20. Voltage Limiter
21. Voltage at Taillight Socket (Vehicles with Taillights)
22. Taillight Bulb Socket
23. Voltage at Headlight Socket
24. Brake Pedal Limit Switch
25. Park Brake Pedal Limit Switch
26. Horn Switch
27. Voltage at Horn
28. Battery Condition Indicator
29. Hour Meter

TEST PROCEDURE 1 – BATTERIES / VOLTAGE CHECK

See General Warning, Section 10, Page 10-1.

1. With batteries connected and using a multimeter set to 200 volts DC, place red (+) probe on the positive (+) post of battery no. 1 and the black (–) probe on the negative (–) post of battery no. 6 (**Figure 11-11, Page 11-16**). The multimeter should indicate at least 48 volts with the batteries fully charged. If not, check for loose battery connections or a battery installed in reverse polarity. The batteries are explained in detail in another section. See **Section 13 – Batteries**.

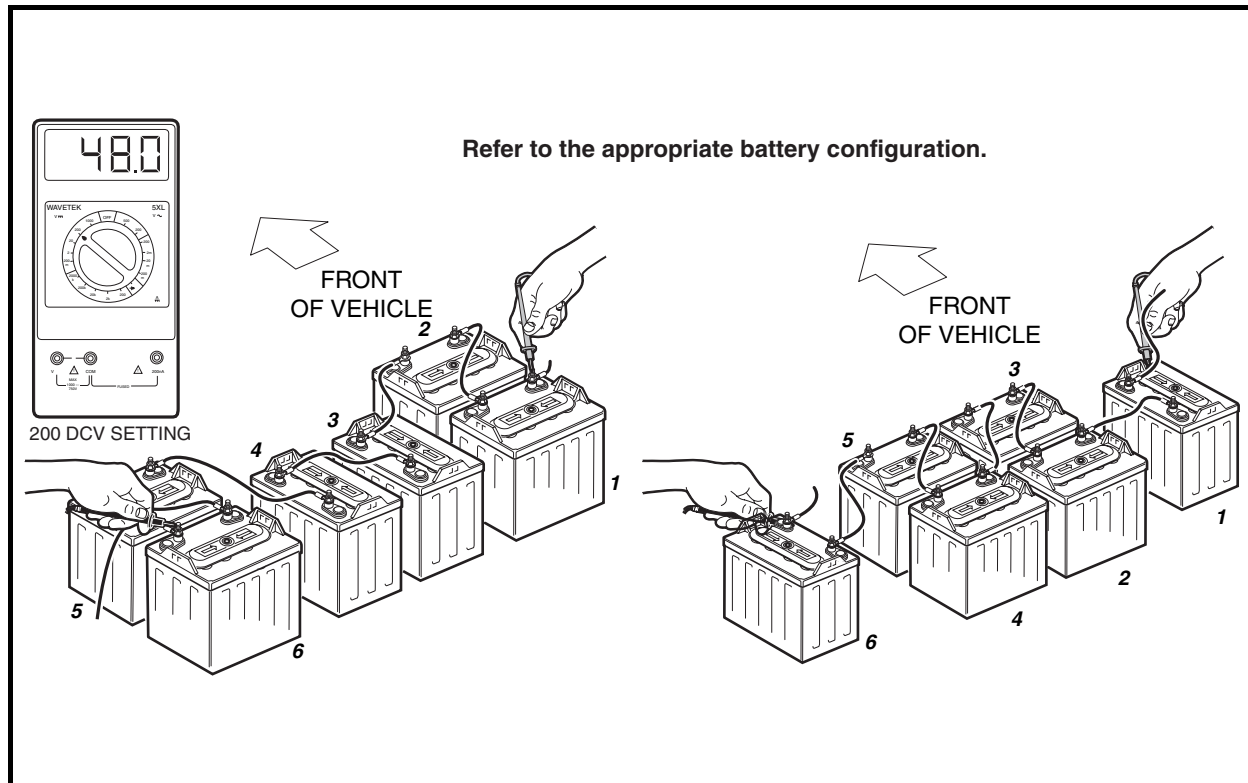


Figure 11-11 Battery Test

TEST PROCEDURE 2 – KEY SWITCH

See General Warning, Section 10, Page 10-1.

1. With batteries disconnected, place red (+) probe of multimeter set to 200 ohms on large terminal of solenoid (with red wire attached) (**Figure 11-12, Page 11-17**).
2. Disconnect the two-pin connector from the MCOR and use an insulation-piercing probe to connect the black (–) multimeter probe on the blue wire near the two-pin connector.
3. With the key switch OFF, the reading should be no continuity. If continuity is shown, check the key switch, wires and terminals, then replace parts as required.
4. Insert the key and turn the switch ON. The reading should be continuity (less than 100 ohms).
5. If the reading is incorrect, check the key switch, wires and terminals, then replace parts as required.
6. Connect the two-pin connector to the MCOR.
7. Place red (+) probe of multimeter on large terminal of solenoid (with red wire attached) and place black (–) probe at green/white wire from the Forward/Reverse limit switch no. 1 (**Figure 11-12, Page 11-17**).

8. Press and hold the accelerator pedal to activate the accelerator pedal limit switch.
9. With the key switch OFF the reading should be no continuity (less than 100 ohms).
10. Insert key and turn switch ON while continuing to press accelerator pedal. Reading should be continuity.
11. If the reading is incorrect, check the key switch, MCOR limit switch, wires and terminals, then replace parts as required.

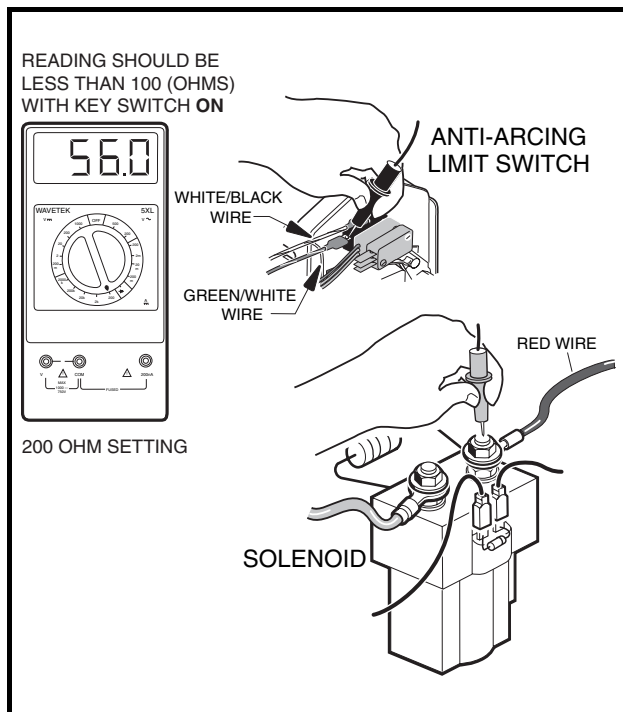


Figure 11-12 Key Switch Test

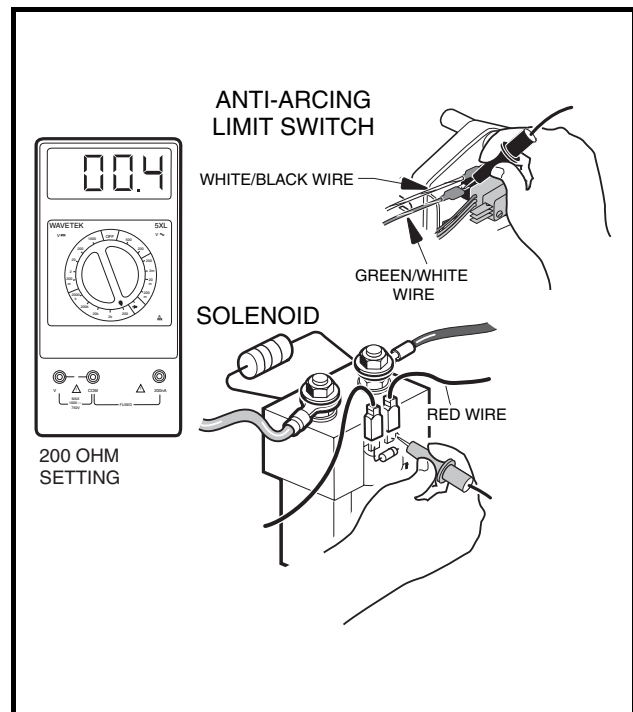


Figure 11-13 Forward/Reverse Anti-Arcing Limit Switch Test

TEST PROCEDURE 3 – FORWARD/REVERSE ANTI-ARCING LIMIT SWITCH

See General Warning, Section 10, Page 10-1.

NOTE: There are three limit switches on the Forward/Reverse switch. The Forward/Reverse anti-arcing limit switch is the one closest to the vehicle body.

1. Disconnect the battery cables as instructed. See **WARNING “To avoid unintentionally starting...”** in **General Warning, Section 10, Page 10-1.**
2. Place the red (+) probe of the multimeter (set for 200 ohms) on the small activating coil terminal of the solenoid that has the red wire connected. Place the black (–) probe on the no. 1 anti-arcing limit switch at the normally open (NO) terminal (**Figure 11-13, Page 11-17**).
3. Reading should show continuity when Forward/Reverse handle is placed in either FORWARD or REVERSE and no continuity when in NEUTRAL. If not, check wires and terminals. If readings are still incorrect, replace switch.

TEST PROCEDURE 4 – SOLENOID ACTIVATING COIL AND DIODE

See General Warning, Section 10, Page 10-1.

1. Disconnect the battery cables as instructed. See WARNING “To avoid unintentionally starting...” in General Warning, Section 10, Page 10-1.
2. Remove the two small wire terminals from the solenoid.
3. The diode must be checked and found to be functioning correctly **before** the activating coil resistance can be accurately measured. The diode can **only** be tested using a continuity test light (CCI P/N 1011273).
 - 3.1. Place the probe end of the tester on the small terminal of the solenoid marked positive (+) and place the alligator clip of the tester on the other small activating coil terminal (**Figure 11-14, Page 11-18**). The tester should illuminate, indicating continuity.
 - 3.2. Reverse the positions of the probe and alligator clip (**Figure 11-15, Page 11-18**). The tester should **not** illuminate. If any other reading is obtained, the diode must be replaced. If the diode is functioning correctly, proceed to step 5.

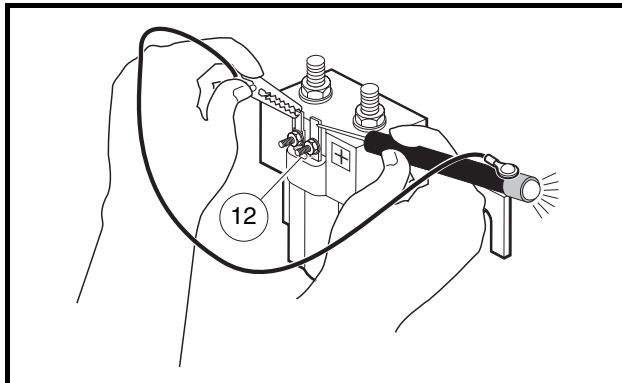


Figure 11-14 Diode Test – Probe Position One

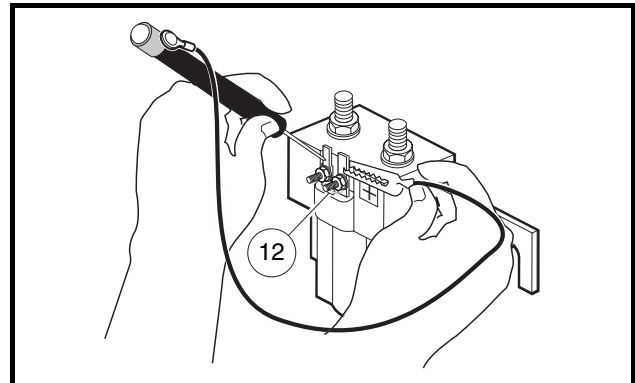


Figure 11-15 Diode Test – Probe Position Two

4. To remove the diode, carefully clip the two leads where they attach to the solenoid terminals (**Figure 11-16, Page 11-18 and Figure 11-17, Page 11-18**). See following NOTE.

NOTE: The diode must be functioning correctly before checking the resistance of the activating coil. In the case of a failed diode, the diode must be removed before the coil resistance can be checked.

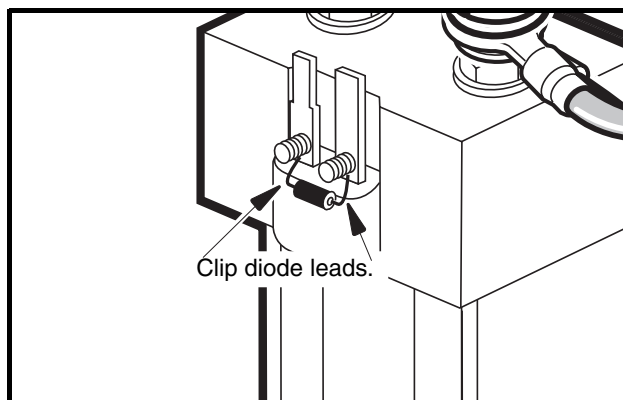


Figure 11-16 Diode Removal

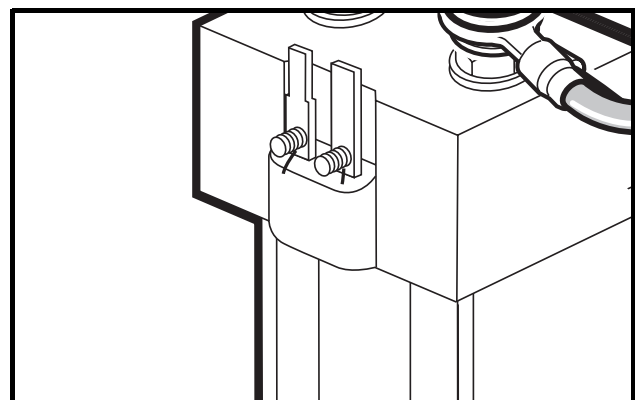


Figure 11-17 Solenoid with Diode Removed

- Place red (+) probe of the multimeter on the positive (+) solenoid terminal. Place the black (–) probe on the other small solenoid terminal. A reading of 180 to 190 ohms should be obtained (**Figure 11-18, Page 11-19**). If not, replace the solenoid.
- If a failed diode was removed, replace the diode by installing a new diode assembly (CCI P/N 1014948), making sure that the red ring terminal of the replacement diode is connected to the positive (+) solenoid terminal.

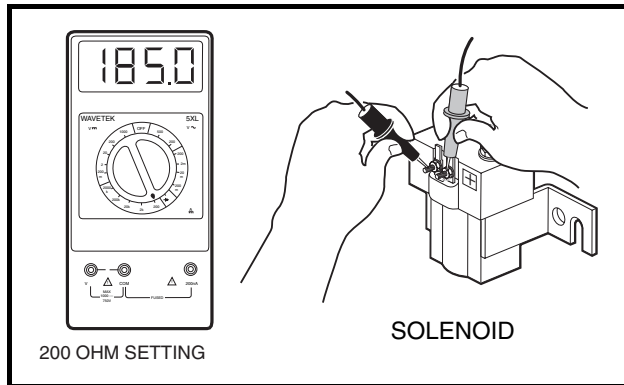


Figure 11-18 Solenoid Activating Coil Test

TEST PROCEDURE 5 – FORWARD/REVERSE SWITCH

See General Warning, Section 10, Page 10-1.

- Disconnect the battery cables as instructed. See **WARNING “To avoid unintentionally starting...”** in General Warning, Section 10, Page 10-1.
- Use a multimeter set to 200 ohms to test the Forward/Reverse switch in both directions. With Forward/Reverse handle in FORWARD, place red (+) probe of multimeter on M– terminal of speed controller and place black (–) probe on S1 motor terminal. Meter should indicate continuity (**Figure 11-19, Page 11-19**).
- With Forward/Reverse handle in FORWARD, place red (+) probe on A2 motor terminal and place the black (–) probe on the S2 motor terminal. Meter should indicate continuity (**Figure 11-20, Page 11-19**).

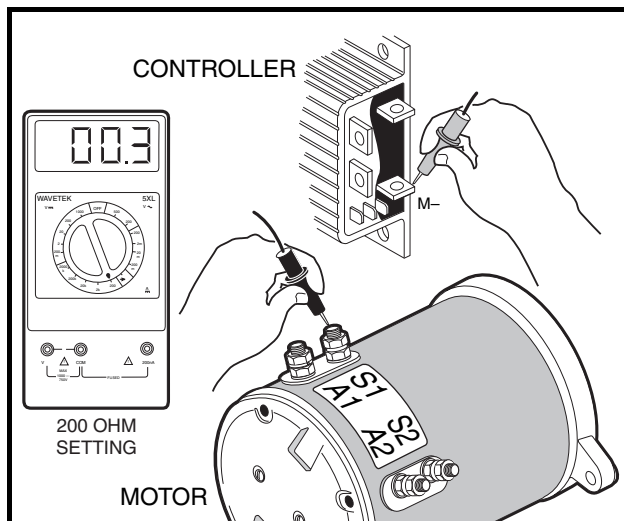


Figure 11-19 Forward/Reverse Test (Forward Position)

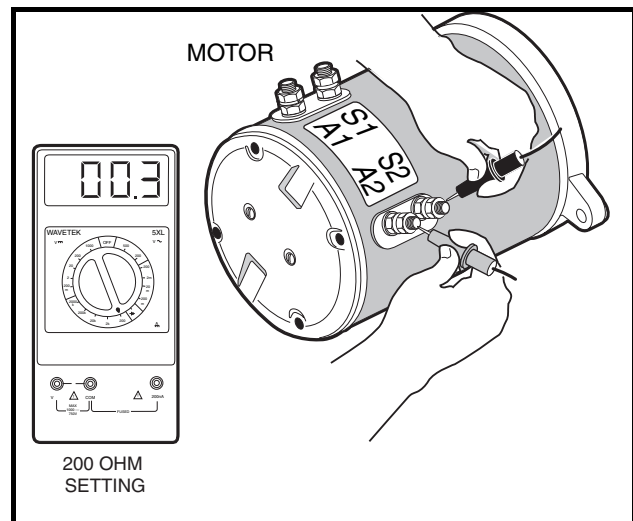


Figure 11-20 Forward/Reverse Continuity Test (Forward Position)

Test Procedure 5 – Forward/Reverse Switch, Continued:

4. With Forward/Reverse handle in REVERSE, place red (+) probe on speed controller M– terminal and place black (–) probe on S2 motor terminal. Meter should indicate continuity (**Figure 11-21, Page 11-20**).
5. With Forward/Reverse handle in REVERSE, place red (+) probe on the A2 motor terminal and the black (–) probe on the S1 motor terminal. Meter should indicate continuity. If continuity is not obtained, and all wires and connections are correct, replace Forward/Reverse switch (**Figure 11-22, Page 11-20**).

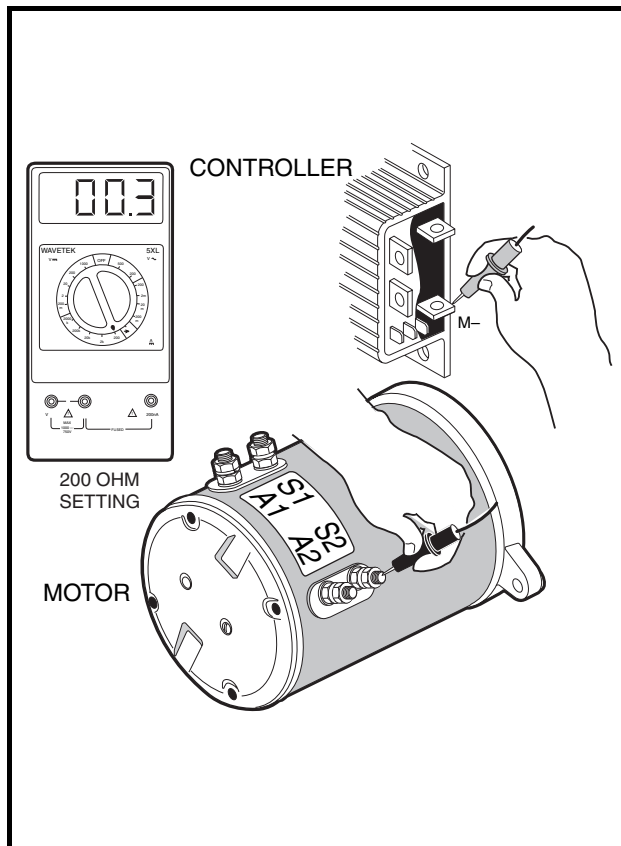


Figure 11-21 Forward/Reverse Test (Reverse Position)

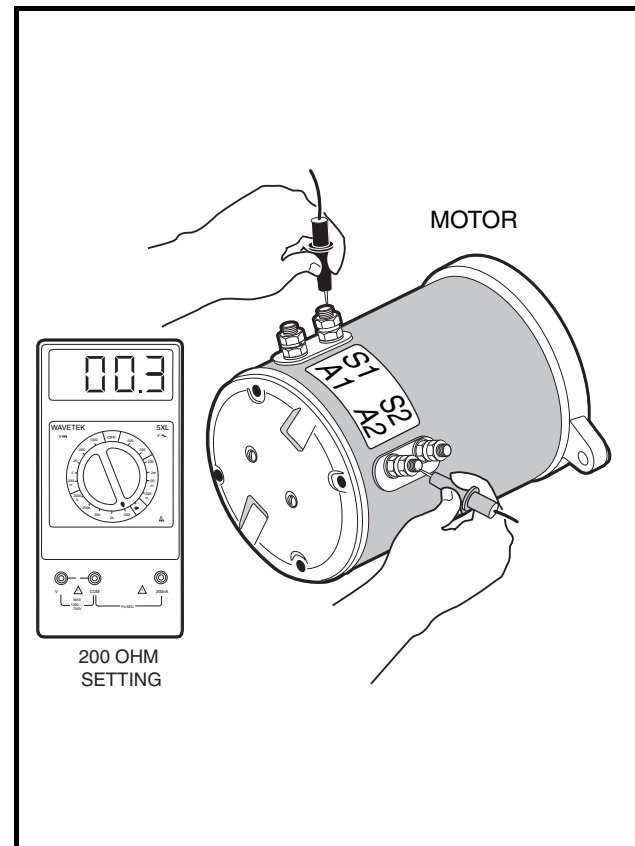


Figure 11-22 Forward/Reverse Continuity Test (Reverse Position)

TEST PROCEDURE 6 – SOLENOID CONTACTS (POWER OFF) AND RESISTOR

See General Warning, Section 10, Page 10-1.

1. Disconnect the battery cables as instructed. See **WARNING “To avoid unintentionally starting...”** in **General Warning, Section 10, Page 10-1**.
2. Remove all wires from the large posts of the solenoid. Remove resistor assembly. Place the red (+) probe of the multimeter on one of the large posts of the solenoid and the black (–) probe of the meter on the other large post on the solenoid. Multimeter should indicate no continuity. If multimeter indicates continuity, replace solenoid (**Figure 11-23, Page 11-21**).
3. Use a multimeter set to 2k ohms to check for resistance between both resistor terminals. If reading is not approximately 250 ohms, replace the resistor (**Figure 11-24, Page 11-21**).

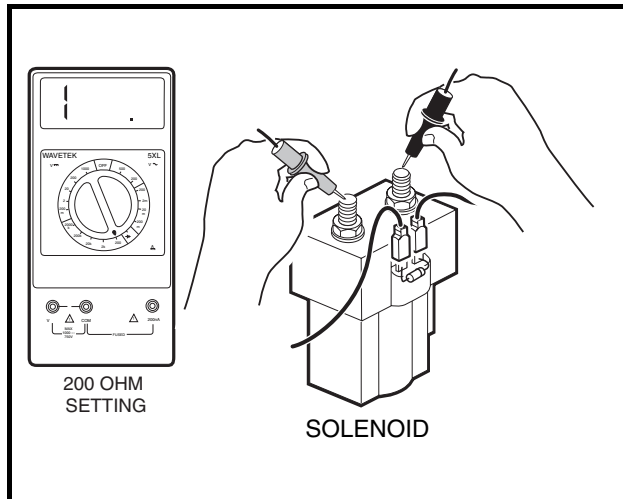


Figure 11-23 Solenoid Contact Test

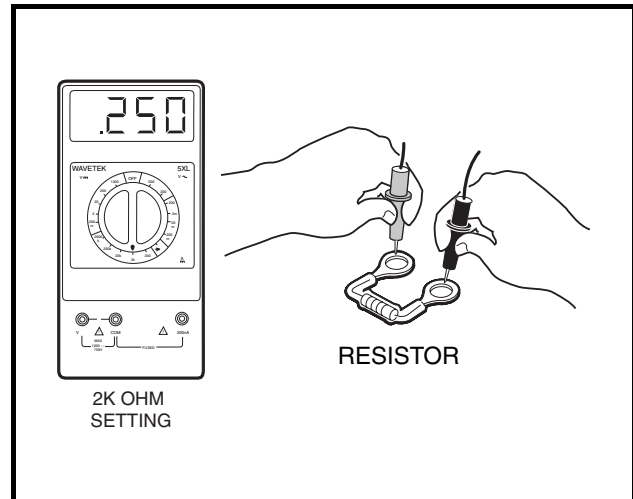


Figure 11-24 Resistor Test

TEST PROCEDURE 7 – MOTOR CONTROLLER OUTPUT REGULATOR (MCOR)

See General Warning, Section 10, Page 10-1.

Test Procedure 7A – MCOR Limit Switch Continuity Test

1. Disconnect the battery cables as instructed. See **WARNING “To avoid unintentionally starting...”** in **General Warning, Section 10, Page 10-1.**
2. Place chocks at the front wheels and lift the rear of the vehicle with a chain hoist or floor jack. Position jack stands under the frame crossmember between the spring mount and side stringer, just forward of each rear wheel. See **WARNING “Lift only one end...”** in **General Warning, Section 10, Page 10-2.**
3. Turn the key switch to the OFF position and place the Forward/Reverse switch in the NEUTRAL position.
4. Test the key switch.
 - 4.1. Remove the center dash panel. See **step 2 of Key Switch Removal, Section 12, Page 12-1.**
 - 4.2. Using a multimeter set to 200 ohms, place the red (+) probe on the key switch terminal with the blue wire. Place the black (–) probe on the other key switch terminal.
 - 4.3. With the key switch in the OFF position, the multimeter should indicate that continuity is not present.
 - 4.4. With the key switch in the ON position, the multimeter should indicate that continuity is present.
 - 4.5. If any other reading is obtained, replace the key switch. See **Key Switch Removal, Section 12, Page 12-1.**
 - 4.6. If the key switch operates as described in the previous steps, install the dash panel in the reverse order of removal and proceed to the following step.
5. Test the MCOR limit switch. See following **NOTE.**

NOTE: Make sure that the key switch is operating correctly and that the key switch and dash panel are properly installed before proceeding.

- 5.1. With batteries connected and using a multimeter set to 200 volts DC, place the black (–) probe on the battery no. 6 negative (–) post and place the red (+) probe (with insulation-piercing probe) on the green/white wire close to the two-pin connector on the MCOR.
- 5.2. With the key switch in the ON position, and Forward/Reverse switch in the NEUTRAL position, the voltage reading should be zero volts. When the accelerator pedal is pressed, the voltage reading should be approximately 48 volts (full battery voltage).

Test Procedure 7A – MCOR Limit Switch Continuity Test, Continued:

- 5.3. If the voltage reading is 48 volts when the accelerator pedal is not pressed, check the pedal group for proper adjustment. **See Section 5 – Accelerator and Brake Pedal Group in the appropriate maintenance and service manual.**
- 5.4. If the voltage reading is zero volts when the accelerator pedal is pressed, check the limit switch circuit using the following test procedures.
 - 5.4.1. Using a multimeter set to 200 volts DC, place black (–) probe on battery no. 6 negative (–) post and the place red (+) probe (with insulation-piercing probe) on the blue wire where it connects to the MCOR. With the key switch ON, the reading should be approximately 48 volts (full battery voltage).
 - 5.4.2. If the reading is zero volts, check the continuity of the blue wire that goes from the key switch to the MCOR.
 - 5.4.3. If the reading is approximately 48 volts, proceed to the step 5.4.4.
 - 5.4.4. Using a multimeter set to 200 volts DC, place the black (–) probe on the battery no. 6 negative (–) post and place the red (+) probe (with insulation-piercing probe) on the green/white wire where it connects to the MCOR. With the key switch ON, the Forward/Reverse switch in NEUTRAL and the accelerator pedal pressed, the reading should be approximately 48 volts (full battery voltage).
 - 5.4.5. If the reading is zero volts, test the continuity of the MCOR limit switch and the green/white wire. If the limit switch does not pass the continuity test, replace the MCOR. **See MCOR Removal, Section 12, Page 12-15.**

Test Procedure 7B – MCOR Voltage

1. Disconnect the battery cables as instructed. **See WARNING “To avoid unintentionally starting...” in General Warning, Section 10, Page 10-1.**
2. Disconnect the 6-gauge green wire from the A1 motor terminal and insulate the wire terminal by wrapping electrical tape around it.
3. Place chocks at the front wheels and lift the rear of the vehicle with a chain hoist or floor jack. Position jack stands under the frame crossmember between the spring mount and side stringer, just forward of each rear wheel. **See WARNING “Lift only one end...” in General Warning, Section 10, Page 10-2.**
4. Connect the battery cables, positive (+) cable first, and tighten to 110 in-lb (12.4 N·m). Coat with Battery Terminal Protector Spray (CCI P/N 1014305) to minimize corrosion.
5. Using a multimeter set to 200 volts DC, place red (+) probe on battery no. 1 positive post and place black (–) probe (with insulation-piercing probe) on the purple wire at a point close to the three-pin connector at the MCOR. The reading should be approximately 48-50 volts (full battery voltage).
6. If reading is zero volts, check the purple wire continuity from the three-pin connector at the MCOR to the speed controller. Check terminal positions in three-pin connector at the MCOR and the speed controller. If all of the continuity readings are correct and the connectors are wired correctly, replace the speed controller.
7. With multimeter set to 20 volts DC, place the black (–) probe on battery no. 6 negative post and the red (+) probe (with insulation-piercing probe) on the black wire at a point close to the three-pin connector at the MCOR. The reading should be zero volts.
8. With the key switch in the ON position and the Forward/Reverse switch in the FORWARD position, press the accelerator pedal until the solenoid clicks. The reading should be approximately 7.8 volts.

9. If reading is zero volts with the key switch ON, Forward/Reverse switch in FORWARD, and the accelerator pedal pressed, check the black wire continuity and the three-pin connector at the MCOR. Check terminal positions in three-pin connector at the MCOR and the 16-pin connector. If all of the continuity readings are correct and the connectors are wired correctly, replace the speed controller.
10. With multimeter set to 20 volts DC, place the black (–) probe on battery no. 6 negative post and the red (+) probe (with insulation-piercing probe) on the 18-gauge yellow wire at a point close to three-pin connector at the MCOR. The reading should be approximately zero volts. With the key switch in the ON position and the Forward/Reverse switch in the FORWARD position, slowly press the accelerator pedal and note the readings on the multimeter. As the pedal is pressed, the reading should increase until it reaches approximately 7.8 volts when the pedal is fully pressed.
11. If reading does not increase as the pedal is pressed, replace the MCOR.
12. If the reading is not approximately 7.8 volts with the pedal fully pressed, the vehicle will not operate at rated top speed. Check the MCOR resistance.
 - 12.1. Disconnect the battery cables as instructed. **See WARNING “To avoid unintentionally starting...” in General Warning, Section 10, Page 10-1.**
 - 12.2. Disconnect the 18-gauge yellow wire at the speed controller J3 terminal and disconnect the 18-gauge green wire from the half-speed reverse limit switch (limit switch no. 3).
 - 12.3. Using a multimeter set for 20k ohms, connect the red (+) probe of the multimeter to the yellow wire at the MCOR three-pin connector with an insulation-piercing probe. Connect black (–) probe to the purple wire with an insulation-piercing probe.
 - 12.4. With the accelerator pedal fully up (not pressed), the multimeter should read approximately 1k ohms.
 - 12.5. Slowly press the accelerator pedal while monitoring the multimeter. The resistance should rise as the pedal is pressed. When the pedal is all the way to the floor, the multimeter should indicate between 5.67k ohms and 7.43k ohms. **See following NOTE.**
- NOTE:** *Failure to disconnect the 18-gauge yellow and green wires, as instructed in step 12.2 will result in resistance readings other than those described in steps 12.4 through 12.8.*
- 12.6. Using a multimeter set for 20k ohms, connect the red (+) probe of the multimeter to the yellow wire at the MCOR three-pin connector with an insulation-piercing probe. Connect black (–) probe to the black wire with an insulation-piercing probe.
- 12.7. With the accelerator pedal fully up (not pressed), the multimeter should indicate between 5.67k ohms and 7.43k ohms.
- 12.8. Slowly press the accelerator pedal while monitoring the multimeter. The resistance should drop as the pedal is pressed. When the pedal is all the way to the floor, the multimeter should indicate approximately 1k ohms.
- 12.9. If the MCOR does not operate as described, replace the MCOR.
13. Connect the 18-gauge yellow wire to the speed controller J3 terminal and connect the 18-gauge green wire to the half-speed reverse limit switch (limit switch no. 3).
14. Connect the 6-gauge green wire to the A1 motor terminal.
15. Connect the battery cables, positive (+) cable first, and tighten to 110 in-lb (12.4 N·m). Coat with Battery Terminal Protector Spray (CCI P/N 1014305) to minimize corrosion.

TEST PROCEDURE 8 – SOLID STATE SPEED CONTROLLER

See General Warning, Section 10, Page 10-1.

⚠ DANGER

- Turn the key switch OFF, place the Forward/Reverse handle in NEUTRAL, and disconnect the battery cables as instructed. See WARNING “To avoid unintentionally starting...” in General Warning, Section 10, Page 10-1. Failure to do so may cause the vehicle to run over you, resulting in severe injury or death.
1. Because the solid state speed controller is a sealed solid state unit, it requires almost no maintenance. It is recommended, however, the following two operations be done occasionally.
 - 1.1. Make sure electrical connections to controller are tight. When checking controller bus bar connections for tightness, be sure to use double-wrench technique to avoid stressing bus bars and cracking seals.
 - 1.2. Remove any corrosion or accumulation of dirt, acid, fertilizer etc., from the terminal area. It is especially important that the controller terminal face be free of dirt and debris to help prevent electrical leakage that could cause faulty operation.
 2. Check for solenoid input. **See following NOTE and WARNING.**

NOTE: Before attempting the following tests, the rear of the vehicle must be raised and secured on jack stands with the drive wheels off the ground.

⚠ WARNING

- Lift only one end of the vehicle at a time. Use a suitable lifting device (chain hoist or hydraulic floor jack) with 1000 lb. (454 kg) minimum lifting capacity. Do not use lifting device to hold vehicle in raised position. Use approved jack stands of proper weight capacity to support the vehicle and chock the wheels that remain on the floor. When not performing a test or service procedure that requires movement of the wheels, lock the brakes.
- 2.1. Disconnect the battery cables as instructed. **See WARNING “To avoid unintentionally starting...” in General Warning, Section 10, Page 10-1.**
 - 2.2. Remove the 6-gauge white wire from the A2 motor terminal and secure wire so it will not make contact with any live components or connections. Connect the battery cables, positive (+) cable first.
 - 2.3. Place Forward/Reverse handle in either FORWARD or REVERSE, turn key switch to ON, and press accelerator pedal until limit switches activate. This should cause solenoid to operate with an audible click.
 - 2.4. Using a multimeter set for 200 volts DC, place the red (+) probe on the small solenoid activating terminal with the red wire attached, and place the black (–) probe on the other small terminal. Multimeter should read full battery voltage when accelerator is pressed to the floor.
3. Check for controller input voltage.
 - 3.1. Remove the 18-gauge red wire from controller input terminal 1.
 - 3.2. Place Forward/Reverse handle in either FORWARD or REVERSE, turn key switch ON, and press accelerator pedal until limit switches activate. This should cause solenoid to operate with an audible click.
 - 3.3. Place multimeter (set for 200 volts DC) black probe (–) on B– terminal of controller (with 6-gauge black wire attached) and red probe (+) into terminal end of red wire removed from controller terminal 1. Multimeter should indicate full battery voltage with accelerator pedal pressed to floor (**Figure 11-25, Page 11-25**).

- 3.4. If the controller input terminal is not getting full battery voltage, then check wire and connections between the solenoid small post and controller 1 terminal. Replace failed parts.
- 3.5. Disconnect the battery cables as instructed. **See WARNING “To avoid unintentionally starting...” in General Warning, Section 10, Page 10-1.**
- 3.6. Connect the 6-gauge white wire to the A2 motor terminal. Connect the battery cables, positive (+) cable first, and tighten to 110 in-lb (12.4 N·m).

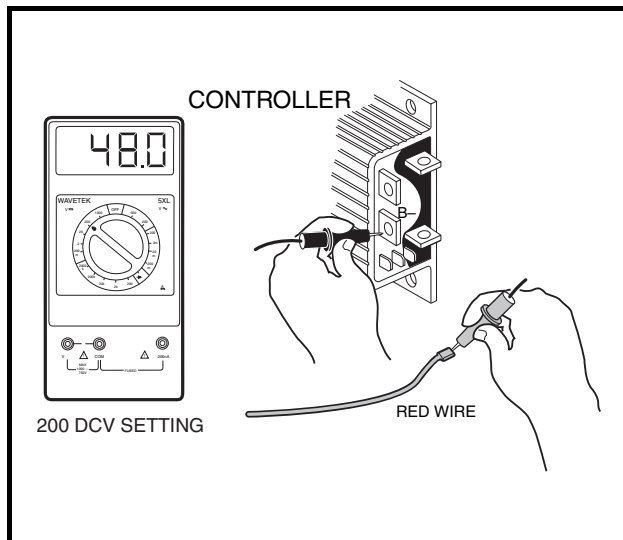


Figure 11-25 Input Voltage Test

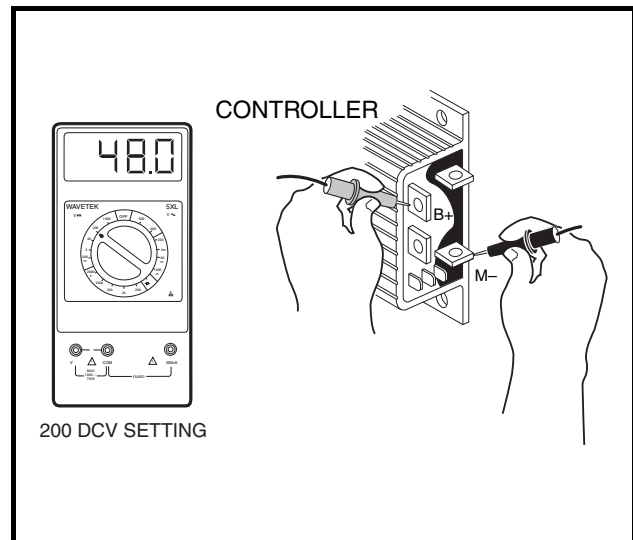


Figure 11-26 Output Voltage Test

4. Check for controller output.
 - 4.1. Disconnect the battery cables as instructed. **See WARNING “To avoid unintentionally starting...” in General Warning, Section 10, Page 10-1.**
 - 4.2. Remove 6-gauge white wire from A2 motor terminal and secure wire so that it cannot make contact with any live components or connections. Connect the battery cables, positive (+) cable first.
 - 4.3. Connect the multimeter (set for 200 volts DC) red probe (+) to the controller B+ terminal and the black probe (-) to the controller M- terminal. The multimeter should display less than 48 volts, which is controller capacitor voltage (**Figure 11-26, Page 11-25**).
 - 4.4. Turn key switch ON, place Forward/Reverse handle in FORWARD and watch multimeter as you press the accelerator pedal. With the accelerator pedal fully pressed, the multimeter should indicate full battery voltage. If the multimeter reading does not rise to full battery voltage (with a properly functioning potentiometer and correct pedal adjustment), then the controller has failed.
 - 4.5. Discharge the controller as instructed. **See WARNING “After disconnecting the batteries...” in General Warning, Section 10, Page 10-1.** Attach the 6-gauge white wire to the A2 motor terminal. Connect the battery cables, positive (+) cable first, and tighten to 110 in-lb (12.4 N·m).
5. Check for plug diode.
 - 5.1. Disconnect the battery cables as instructed. **See WARNING “To avoid unintentionally starting...” in General Warning, Section 10, Page 10-1.**
 - 5.2. Remove wires from controller B+ terminal using two wrenches to keep the posts from turning.

Test Procedure 8 – Solid State Speed Controller, Continued:

- 5.3. Use a multimeter (set to diode) to test the resistance between the controller A2 and B+ terminals. This test is for the presence of a functioning diode inside the controller. If the diode is shorted either open or closed, the controller has failed. With the black (–) probe on the B+ terminal and the red (+) probe on the A2 terminal, reading should indicate continuity. Reverse the probes and the multimeter should indicate no continuity.
- 5.4. Connect wires to controller B+ terminal. Connect the battery cables, positive (+) cable first, and tighten to 110 in-lb (12.4 N·m).

TEST PROCEDURE 9 – ONBOARD COMPUTER LOCKOUT CIRCUIT**See General Warning, Section 10, Page 10-1.**

NOTE: Step 1 is for vehicles with charger receptacles only. For vehicles with onboard chargers, proceed to step 2.

1. Inspect the charger receptacle for water in the contacts. If water is found, proceed as follows:

NOTE: If battery pack is wet, make sure 18-gauge gray wire from OBC is not touching batteries. Wire tie the 18-gauge gray lead and 18-gauge gray wire to wire harness if necessary.

- 1.1. Disconnect the battery cables as instructed. **See WARNING “To avoid unintentionally starting...” in General Warning, Section 10, Page 10-1.**
- 1.2. Remove the receptacle from the vehicle. **See Charger Receptacle Removal, Section 12, Page 12-14.**
- 1.3. Dry the receptacle by wiping it with a clean dry cloth and by blowing into contacts with compressed air.
- 1.4. Reinstall the charger receptacle.
2. With batteries disconnected, inspect the sense lead fuse in the gray wire from OBC. Using a multimeter (set to 200 ohms), check fuse for continuity. If continuity is present, fuse is good. If no continuity is present, the fuse is blown and must be replaced.
3. It is possible the OBC can become “locked-up”, causing the OBC solenoid lockout circuit to malfunction. If this condition is suspected, restart the computer as follows:
 - 3.1. Disconnect the battery cables as instructed. **See WARNING “To avoid unintentionally starting...” in General Warning, Section 10, Page 10-1.**
 - 3.2. Connect the battery cables, positive (+) cable first, and tighten to 110 in-lb (12.4 N·m). Drive the vehicle. If the problem has been corrected, the vehicle will function normally.
4. With batteries disconnected, inspect the wire terminals. Make sure wire terminals are not touching corresponding solenoid terminal posts. Connect the battery cables, positive (+) cable first, and attempt to drive the vehicle.
5. Bypass the OBC solenoid lockout circuit to isolate the problem. Use the following procedure:
 - 5.1. Make sure the batteries are disconnected as instructed and that the controller has been discharged. **See WARNING “To avoid unintentionally starting...” in General Warning, Section 10, Page 10-1.**
 - 5.2. Connect one end of a jumper wire to the small (coil) post of the solenoid (with 18-gauge yellow wire attached). Connect the other end of the jumper wire to the negative (–) post of battery no. 6.
 - 5.3. Connect the battery cables, positive (+) cable first, and tighten terminals to 110 in-lb (12.4 N·m).
 - 5.4. If vehicle can be driven with jumper wire attached, then OBC has failed and must be replaced. If vehicle cannot be driven with jumper wire attached, then refer to the Troubleshooting Guide beginning on page 11-12.

TEST PROCEDURE 10 – BATTERY WARNING LIGHT

See General Warning, Section 10, Page 10-1.

1. Turn key switch OFF and place the Forward/Reverse handle in NEUTRAL. Leave battery cables connected.
2. Disconnect the 18-gauge brown wire from the onboard computer at the three-pin connector (located near the onboard computer).
3. Connect one end of a jumper wire to the brown wire that was removed from the three-pin connector, and connect the other end of the jumper wire to the negative (–) post of battery no. 1. The battery warning light should illuminate. If it does not, proceed to step 4.
4. Remove the center dash. **See step 2 of Key Switch Removal, Section 12, Page 12-1.**
5. Disconnect the spade connector on the 18-gauge brown wire from the battery warning light.
6. Set the multimeter to 200 ohms and connect the black (–) probe to the male side of the brown wire spade connector. Connect the red (+) probe to the brown wire female spade. The multimeter should indicate continuity. If reading is incorrect, repair or replace the wire.
7. Disconnect the 18-gauge orange/white wire from the key switch.
8. Set the multimeter to 200 ohms, connect the black (–) probe to the ring terminal connector on the orange/white wire and connect the red (+) probe to the other end of the wire. The multimeter should indicate continuity. If the reading is incorrect, repair or replace the wire.
9. If both wires test operational, then replace the battery warning light.

TEST PROCEDURE 11 – VOLTAGE AT CHARGER RECEPTACLE RED WIRE SOCKET

See General Warning, Section 10, Page 10-1.

1. Using a multimeter set to 200 volts DC, place the black (–) probe on the negative (–) post of battery no. 6 and place the red (+) probe on the charger receptacle socket connected to the red 10-gauge wire. The reading should be 48-50 volts (full battery voltage).
2. If the reading is zero volts, check the continuity of the 10-gauge red wire at the vehicle receptacle.

TEST PROCEDURE 12 – HALF-SPEED REVERSE LIMIT SWITCH (LIMIT SWITCH NO. 3)

See General Warning, Section 10, Page 10-1.

1. Disconnect the battery cables as instructed. **See WARNING “To avoid unintentionally starting...” in General Warning, Section 10, Page 10-1.**
2. Check for proper wiring and tight connections.
3. Using a multimeter set to 200 ohms, check continuity across common (COM) and normally open (NO); and across common (COM) and normally closed (NC) (**Figure 11-27, Page 11-28 and Figure 11-28, Page 11-28**). With the limit switch lever up (not pressed), readings should be:

COM to NC: Zero (or continuity tester is illuminated)

COM to NO: Infinity (or continuity tester is not illuminated)

With the limit switch lever pressed, readings should be:

COM to NC: Infinity (or continuity tester is not illuminated)

COM to NO: Zero (or continuity tester is illuminated)

4. If meter readings are not correct, replace limit switch.

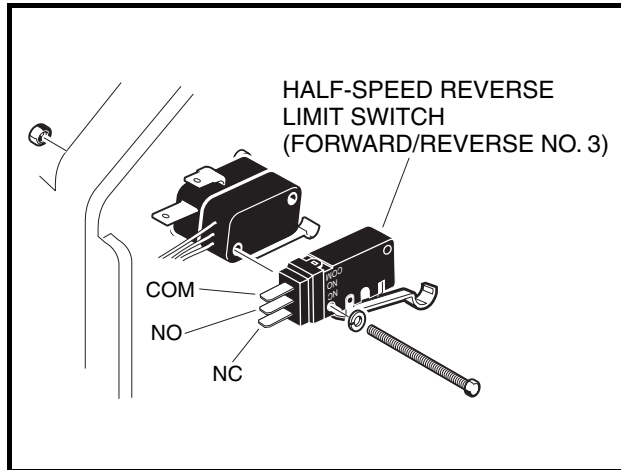
Test Procedure 12 – Half-Speed Reverse Limit Switch (Limit Switch No. 3), Continued:

Figure 11-27 Forward/Reverse Limit Switch

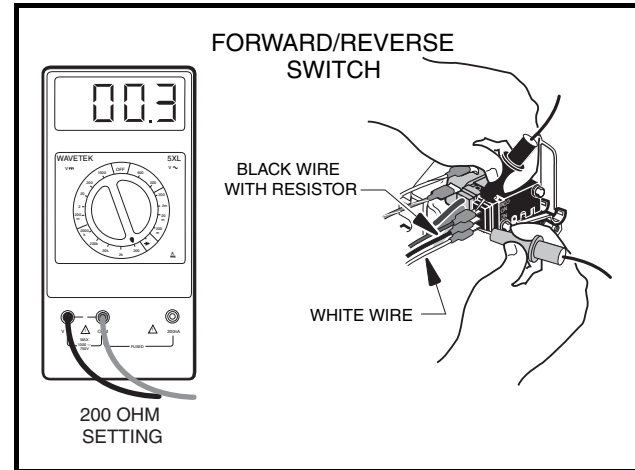


Figure 11-28 Half-Speed Reverse Limit Switch Test

TEST PROCEDURE 13 – HALF-SPEED REVERSE RESISTOR

See General Warning, Section 10, Page 10-1.

1. Disconnect the battery cables as instructed. See **WARNING “To avoid unintentionally starting...”** in **General Warning, Section 10, Page 10-1.**
2. Disconnect black wire from half-speed reverse limit switch located on Forward/Reverse switch (**Figure 11-29, Page 11-28**).
3. Measure resistance.
 - 3.1. Disconnect the three-pin connector (which connects the MCOR to the Forward/Reverse wire harness). See **Wiring Diagrams on page 11-2.**
 - 3.2. With multimeter set to 20k ohms, measure resistance through 18-gauge black wire from Forward/Reverse wire harness (at disconnect from three-pin connector) to end disconnected from half-speed reverse limit switch. Resistance should measure approximately 5100 ohms ($\pm 10\%$) (**Figure 11-29, Page 11-28**).
4. If the meter reading is not correct, replace the wire assembly to the half-speed reverse limit switch.

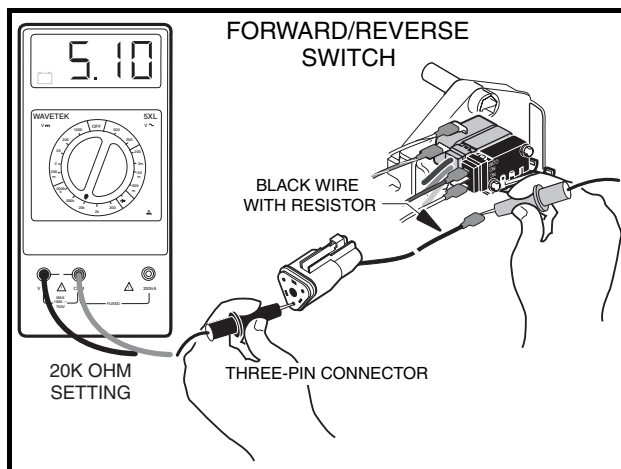


Figure 11-29 Half-Speed Reverse Resistor Test

TEST PROCEDURE 14 – REVERSE BUZZER LIMIT SWITCH

See General Warning, Section 10, Page 10-1.

1. Disconnect the battery cables as instructed. See **WARNING “To avoid unintentionally starting...”** in **General Warning, Section 10, Page 10-1.**
2. Disconnect red/white wire and orange wire from limit switch located on the Forward/Reverse switch assembly.
3. Connect black (–) probe of a multimeter to top terminal of limit switch and connect red (+) probe to the middle (NO) terminal. With the Forward/Reverse handle in NEUTRAL or FORWARD reading should be no continuity. Place the Forward/Reverse handle in REVERSE and reading should be continuity. If readings are not correct replace limit switch.

TEST PROCEDURE 15 – REVERSE BUZZER

See General Warning, Section 10, Page 10-1.

With the batteries connected, use the flow chart (**Figure 11-30, Page 11-29**) as a starting point for troubleshooting the reverse buzzer circuit.

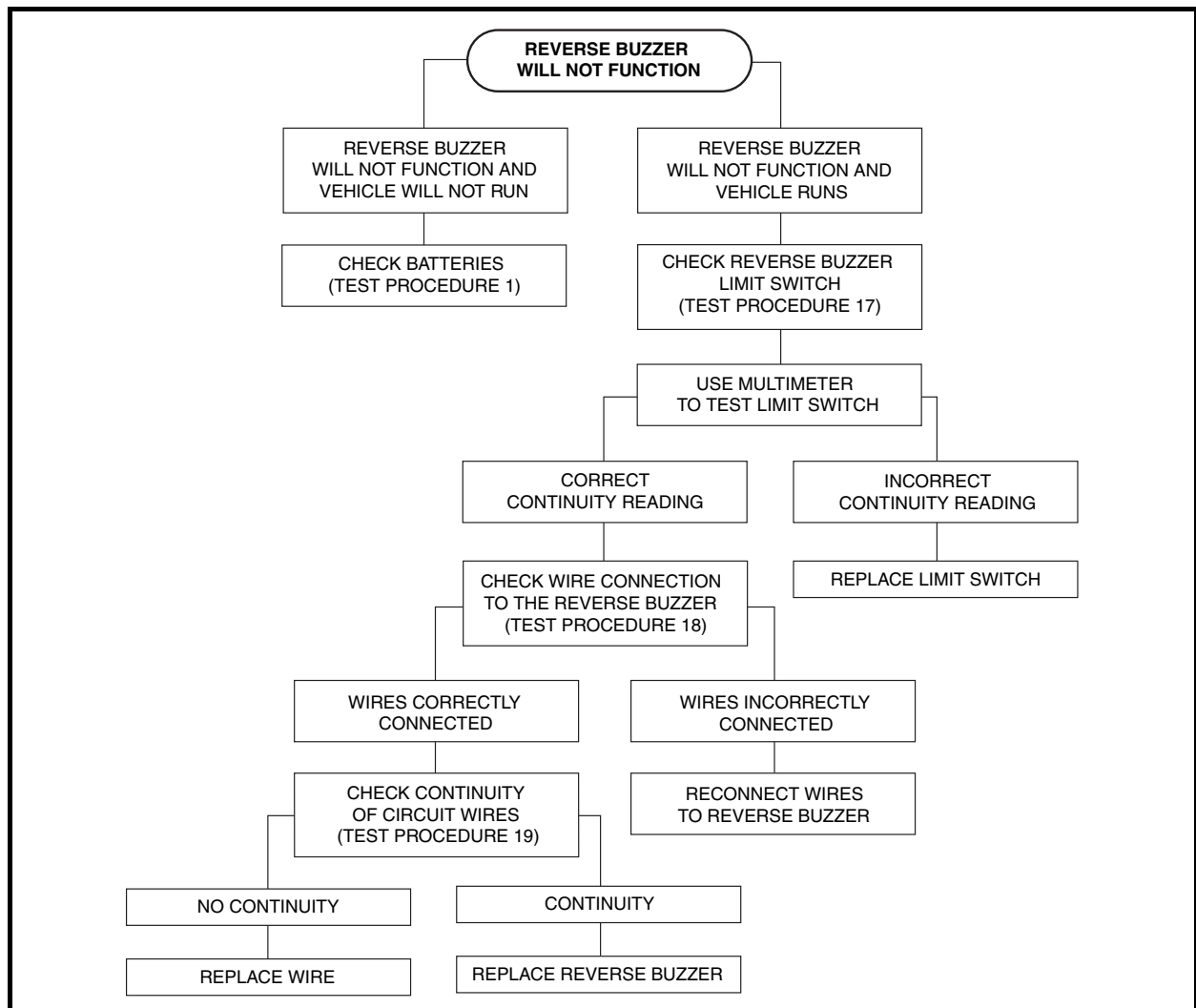


Figure 11-30 Reverse Buzzer Will Not Function

Testing the Reverse Buzzer Wire Connections

1. Before checking wire connections, make sure batteries are disconnected. The red 18-gauge wire should be connected to the (+) terminal of the reverse buzzer. The orange 18-gauge wire should be connected to the (-) terminal on the reverse buzzer.

Testing the Front Mounted Reverse Buzzer Circuit

NOTE: Batteries should remain connected for this test.

1. Disconnect the red/white wire from Forward/Reverse limit switch no. 2 and place the black probe of a multimeter (set to 200 volts DC) on the wire. Place the red probe of the multimeter on the positive (+) post of battery no. 1. The multimeter should register battery voltage. If it does not, replace the red/white wire.
2. Disconnect both wires from Forward/Reverse limit switch no. 2 and place the probes of a continuity tester on the wire terminals of the limit switch. With the limit switch lever down (open circuit), the tester light should not illuminate. With the limit switch lever up (closed circuit), the tester light should illuminate. If tester light does not illuminate (with the limit switch up), replace the limit switch. If the tester light illuminates, replace the reverse buzzer.

Testing the Rear Mounted Reverse Buzzer Circuit (Caryall 6, Villager 6 and 8 and TransPorter vehicles)

1. Disconnect the battery cables as instructed. **See WARNING “To avoid unintentionally starting...” in General Warning, Section 10, Page 10-1.**
2. **Caryall 6 Vehicles:** Remove two bed hold-down bolts that secure the bed to the vehicle frame. Raise bed and secure prop rod to bed frame.
3. Disconnect the orange wire from the reverse buzzer and from the Forward/Reverse limit switch no. 2. Place the red (+) probe of a continuity tester on the orange wire at the Forward/Reverse limit switch end. Place the black (-) probe on the orange wire at the reverse buzzer end. The continuity tester light should illuminate. If it does not, replace the orange wire.
4. Disconnect the red wire from the reverse buzzer. Place the red (+) probe of a continuity tester on the red wire and place the black (-) probe on the large post (with 6-gauge red wire attached) of the solenoid. If the tester light does not illuminate, replace the red wire. If the tester light does illuminate, replace the buzzer.

TEST PROCEDURE 16 – WIRE CONTINUITY

See General Warning, Section 10, Page 10-1.

1. Disconnect the battery cables as instructed. **See WARNING “To avoid unintentionally starting...” in General Warning, Section 10, Page 10-1.**
2. Disconnect one end of the wire to be tested and connect probe of multimeter to each end of the wire. Multimeter should indicate continuity. If reading is incorrect, repair or replace wire.

TEST PROCEDURE 17 – BATTERY VOLTAGE SUPPLY (ONLY FOR VEHICLES WITH HEADLIGHTS)

See General Warning, Section 10, Page 10-1.

1. Place the Forward/Reverse handle in the NEUTRAL position, and chock the wheels.
2. Disconnect the battery cables as instructed. **See WARNING “To avoid unintentionally starting...” in General Warning, Section 10, Page 10-1.**
3. Remove the center dash assembly. **See step 2 of Key Switch Removal, Section 12, Page 12-1.**

4. Connect the battery cables, positive (+) cable first.
5. Place an alligator clip on the black (–) probe of the multimeter and connect the alligator clip to the terminal block located on the frame under the front body (**Figure 11-31, Page 11-31**).
6. Place the red (+) probe of the multimeter on the positive post of battery no. 5. **See following NOTE.**

NOTE: The position and orientation of battery no. 5 varies depending on the vehicle model.

7. Set the multimeter to 20 volts DC. The reading should be 15-17 volts with the headlight switch in the off position.
8. If the reading is incorrect, check the following items:
 - Battery voltage. **See Test Procedure 1 – Batteries / Voltage Check on page 11-16.**
 - Continuity of all ground terminal block wires. **See Test Procedure 16 – Wire Continuity on page 11-30.**
 - Voltage limiter. **See Test Procedure 20 – Voltage Limiter on page 11-37.**

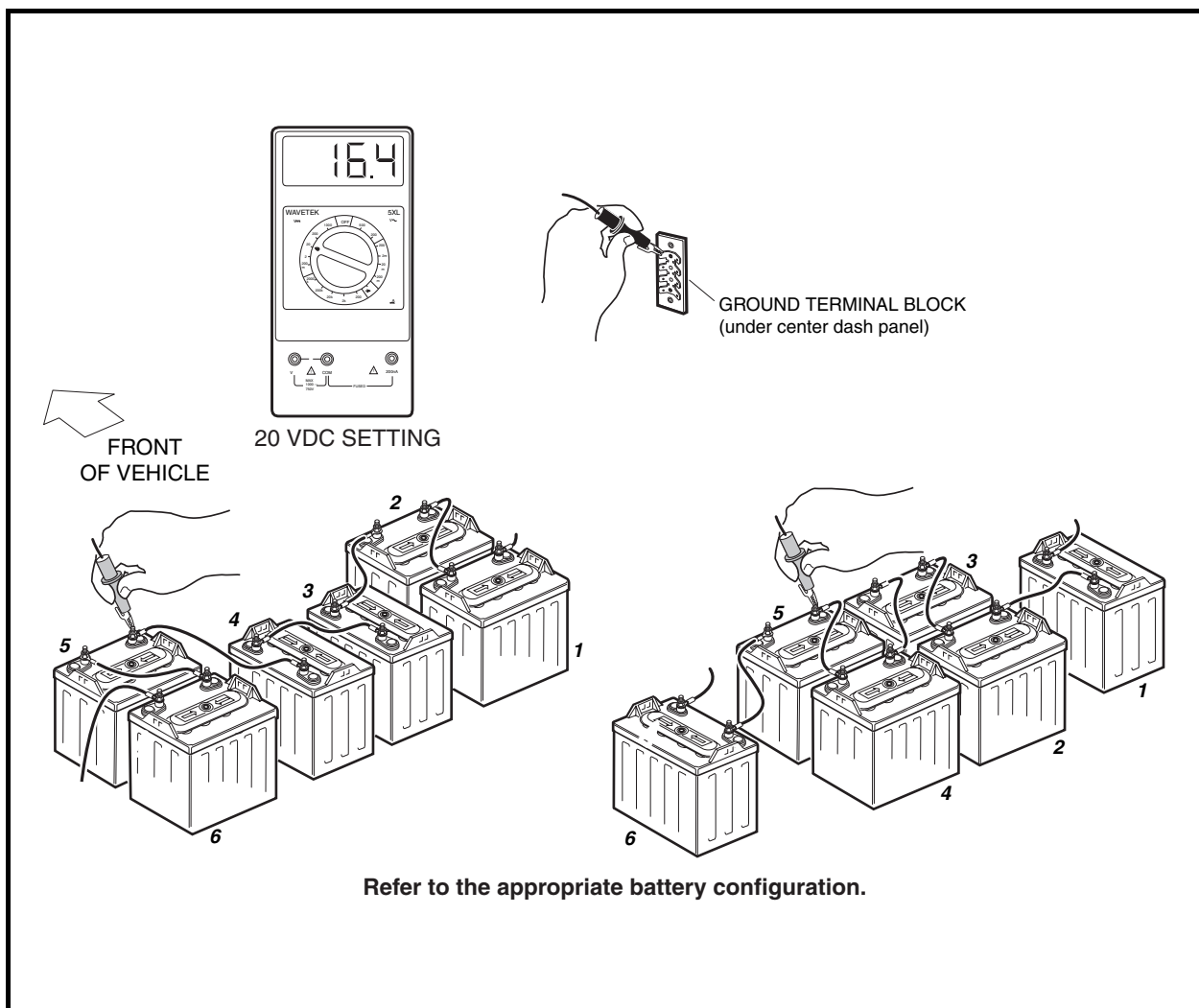


Figure 11-31 Battery Voltage Supply Test

TEST PROCEDURE 18 – LIGHT SWITCH

See **General Warning, Section 10, Page 10-1.**

1. Place the Forward/Reverse handle in the NEUTRAL position, and chock the wheels.
2. Disconnect the battery cables as instructed. See **WARNING “To avoid unintentionally starting...” in General Warning, Section 10, Page 10-1.**
3. Remove the center dash assembly. See **step 2 of Key Switch Removal, Section 12, Page 12-1.**
4. Connect the battery cables, positive (+) cable first.
5. Using a multimeter set to 20 volts DC, place alligator clips on multimeter probes. Connect the black (–) probe to the terminal block under the front body (**Figure 11-32, Page 11-32**).
6. Connect the red (+) probe to the light switch terminal with the brown and blue wires connected to it. See **following NOTE.**

NOTE: Vehicles with headlights only will not be equipped with a brown wire.

7. With the light switch in the on position, the reading should be between 11 and 13 volts DC.
8. If the reading is incorrect, check the following items:
 - Battery voltage. See **Test Procedure 1 – Batteries / Voltage Check on page 11-16.**
 - Continuity of all ground terminal block wires. See **Test Procedure 16 – Wire Continuity on page 11-30.**
 - Voltage limiter. See **Test Procedure 20 – Voltage Limiter on page 11-37.**

For Turf 2 vehicle:

- Check the continuity of the yellow wire from the inline fuse holder to the light switch.
- Check the continuity of the fuse in the inline fuse holder on the yellow wire connected to the negative post of battery number 4.

For Carryall 6, TransPorter, Villager 6, and Villager 8 vehicles:

- Check the continuity of the red wire from the fuse block to the positive post of battery number 4.
- Check the continuity of the accessory fuse (located in the fuse block under the seat).

All vehicles:

9. If the light switch readings are incorrect, and the wires, fuse, and voltage limiter are operating correctly replace the light switch. See **Light Switch Removal, Section 12, Page 12-21.**

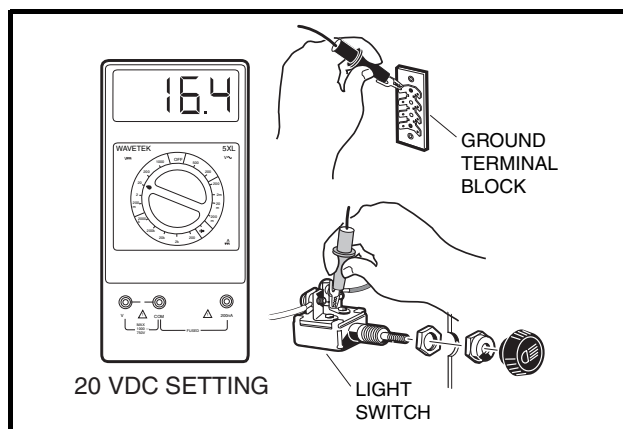


Figure 11-32 Light Switch Test

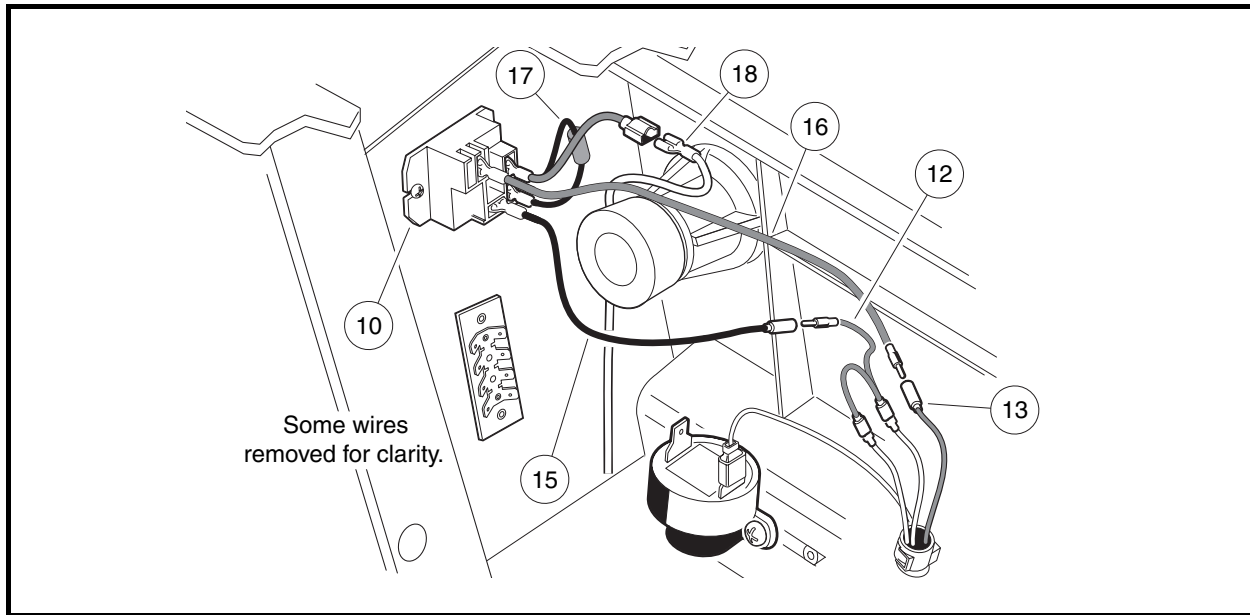


Figure 11-33 Brake Light Relay Test

TEST PROCEDURE 19 – BRAKE LIGHT RELAY

See General Warning, Section 10, Page 10-1.

1. Inspect the brake light relay for proper operation. See following NOTE.

NOTE: The aid of an assistant will be required to inspect the brake light relay for proper operation.

- 1.1. With the key switch in the OFF position and the key removed, press the brake pedal while an assistant observes the brake lights. The brake lights should not function when the key switch is in the OFF position.
- 1.2. Insert the key and turn it to the ON position. With the key switch in the ON position, the brake lights should illuminate when the brake pedal is pressed.
- 1.3. Set the park brake by pressing the brake pedal firmly and tilting the park brake portion of the pedal forward with your foot. The brake lights should not illuminate with the park brake engaged.
2. If the brake lights operate exactly as described in step 1, the brake light relay is operating correctly.
3. If the brake lights do not illuminate when the key switch is ON and the brake pedal is pressed, proceed to step 8.
4. If the brake lights illuminate when the brake pedal is pressed and the key switch is in the OFF position, the brake light relay has failed closed or the blocking diode has failed closed.
5. Disable the vehicle before performing steps 6 and 7.
 - 5.1. Place the Forward/Reverse handle in the NEUTRAL position, and chock the wheels.
 - 5.2. Disconnect the battery cables as instructed. See **WARNING “To avoid unintentionally starting...”** in General Warning, Section 10, Page 10-1.
 - 5.3. Remove the center dash assembly. See **step 2 of Key Switch Removal, Section 12, Page 12-1.**
6. Test the relay for the failed closed condition.
 - 6.1. Remove the voltage suppressor wires (17) from the relay coil terminals (**Figure 11-33, Page 11-33**).
 - 6.2. Remove the two wires (15 and 16) from the relay contact terminals.

Test Procedure 19 – Brake Light Relay, Continued:

- 6.3. Set a multimeter to 200 ohms. Place the black (–) probe of the multimeter on the relay terminal marked COM (common). Place the red (+) probe on the relay terminal marked NO (normally open). The multimeter should indicate no continuity. If the multimeter indicates continuity, the relay has failed closed.
- 6.4. If the relay has failed closed, replace the relay. **See Brake Light Relay Removal, Section 12, Page 12-20.**
7. Test the blocking diode for the failed closed condition.
 - 7.1. Access the component mounting plate by removing the seat or rear access panel (depending on vehicle model).
 - 7.2. Remove the blocking diode by disconnecting it from the solenoid coil and the red wire.
 - 7.3. Set a multimeter to the diode test function (→|←). Place the black (–) probe of the multimeter on the terminal on the opposite side of the white band indicator on the diode (**Figure 11-34, Page 11-34**). Place the red (+) probe on the terminal on the same side of the diode as the white band. The multimeter should indicate an overlimit with no tone emitted. If any other reading is indicated by the multimeter, replace the blocking diode.
 - 7.4. Place the red (–) probe of the multimeter on the terminal on the opposite side of the white band indicator on the diode (**Figure 11-35, Page 11-34**). Place the black (+) probe on the terminal on the same side of the diode as the white band. The multimeter should indicate approximately 546 mV. If the reading is not approximately 546 mV, replace the blocking diode.

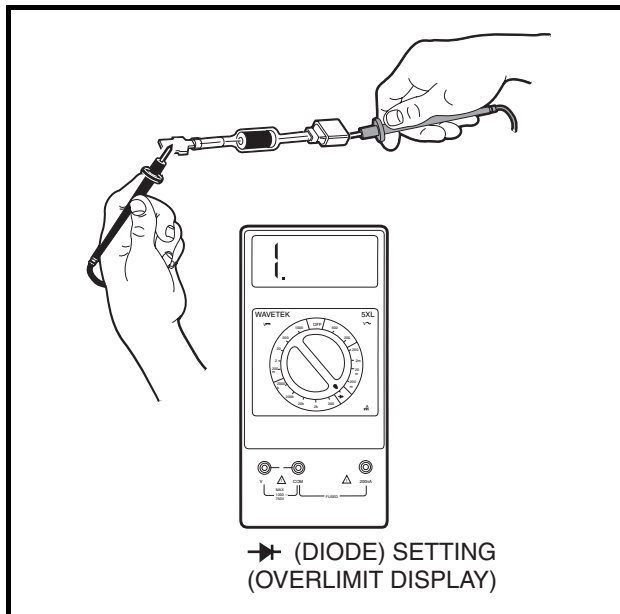


Figure 11-34 Blocking Diode Test

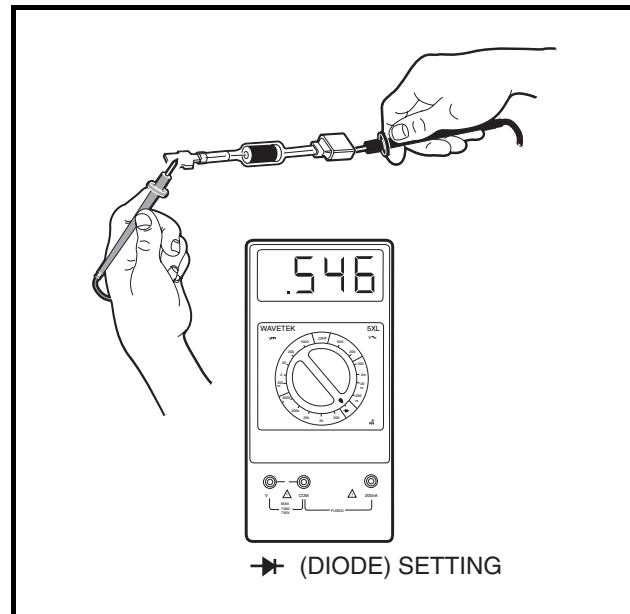


Figure 11-35 Blocking Diode Test – Probes Reversed

8. Bypass the brake light relay.
 - 8.1. Disable the vehicle before proceeding with step 8.
 - 8.1.1. Place the Forward/Reverse handle in the NEUTRAL position, and chock the wheels.
 - 8.1.2. Disconnect the battery cables as instructed. **See WARNING “To avoid unintentionally starting...” in General Warning, Section 10, Page 10-1.**
 - 8.1.3. Remove the center dash assembly. **See step 2 of Key Switch Removal, Section 12, Page 12-1.**

- 8.2. Locate the red jumper wire (12) in the area behind the center dash panel (**Figure 11-33, Page 11-33**).
- 8.3. Disconnect the red jumper wire (12) from the black wire (15).
- 8.4. Disconnect the brown wire (16) from the brown wire (13).
- 8.5. Bypass the relay by connecting the red jumper wire (12) to the brown wire (13) as shown (**Figure 11-33, Page 11-33**).
9. Connect the battery cables, positive (+) cable first.
10. With the relay bypassed, inspect the brake lights for proper operation. **See following NOTE.**

NOTE: The aid of an assistant will be required to inspect the brake light relay for proper operation.

- 10.1. With the key switch in the OFF position and the key removed, press the brake pedal while an assistant observes the brake lights. The brake lights should illuminate, regardless of the key switch position (ON or OFF).
11. If the brake lights do not operate with the relay bypassed, there is most-likely a problem in the brake light circuit other than the brake light relay. Restore the wiring to the original configuration (not bypassed), and proceed to step 14 for additional test procedures.
12. Test the voltage suppressor wire assembly.
 - 12.1. Disconnect the voltage suppressor assembly (17) from the relay coil terminals (**Figure 11-33, Page 11-33**).
 - 12.2. Set a multimeter to the diode test function (→+). Place the black (-) probe of the multimeter on the voltage suppressor red wire (25) (**Figure 11-36, Page 11-35**). Place the red (+) probe on the blue wire (26). The multimeter should indicate an overlimit with no tone emitted.
 - 12.3. Reverse the multimeter probes and observe the multimeter. The multimeter should continue to indicate an overlimit with no tone emitted.
 - 12.4. If a tone is emitted (indicating a closed circuit) then the voltage suppressor has failed closed and should be replaced.

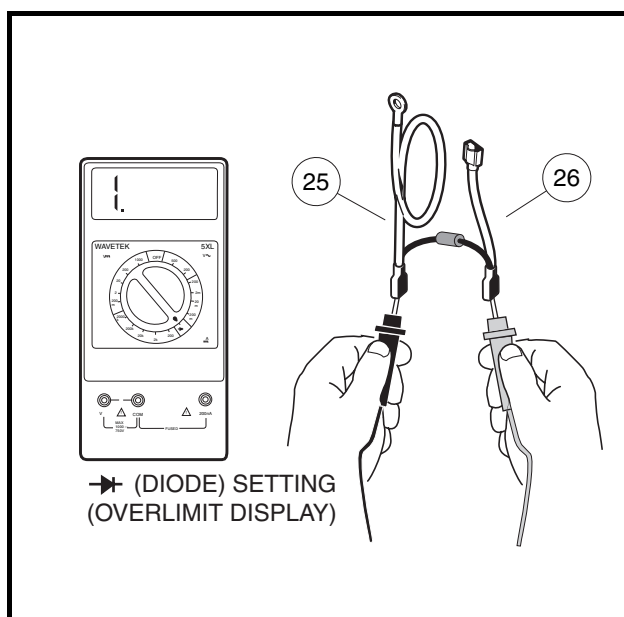


Figure 11-36 Voltage Suppressor Test

Test Procedure 19 – Brake Light Relay, Continued:

13. Test the brake light relay coil.

13.1. Remove the voltage suppressor wire assembly (17) from the relay (10) coil terminals (**Figure 11-37, Page 11-36**).

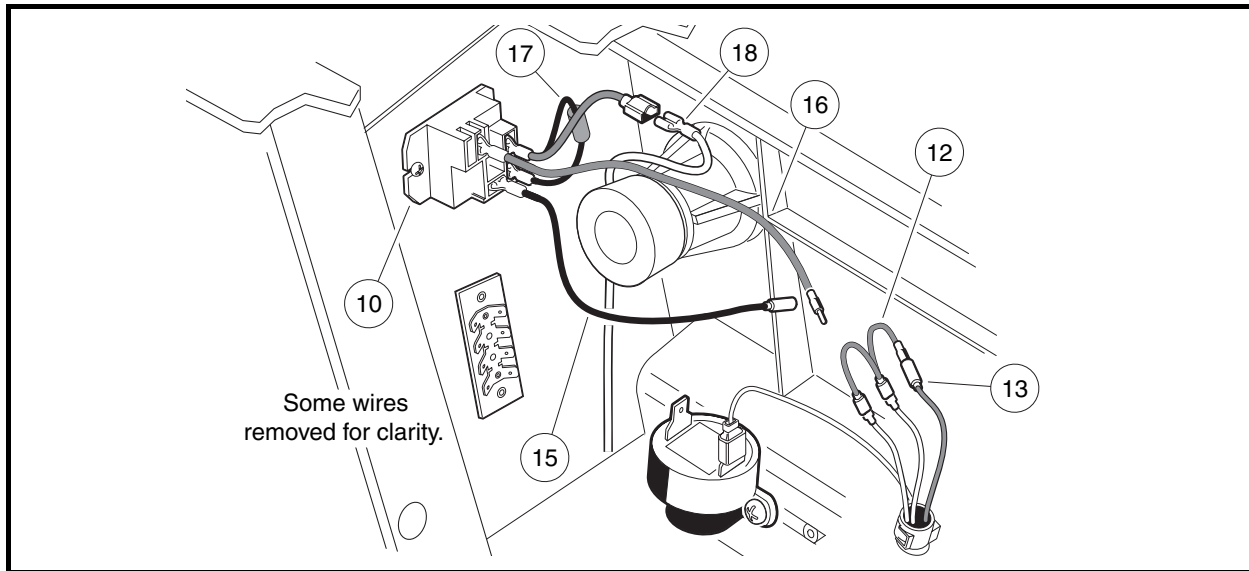


Figure 11-37 Bypassed Brake Light Relay

13.2. Set a multimeter to 20k ohms. Place the black (-) probe of the multimeter on one of the relay coil terminals (**Figure 11-38, Page 11-36**). Place the red (+) probe on the other relay coil terminal. The coil resistance should be between 2.07k and 2.82k ohms. If the reading is incorrect, replace the relay. **See Brake Light Relay Removal, Section 12, Page 12-20.**

13.3. Restore the wiring to the original configuration (not bypassed).

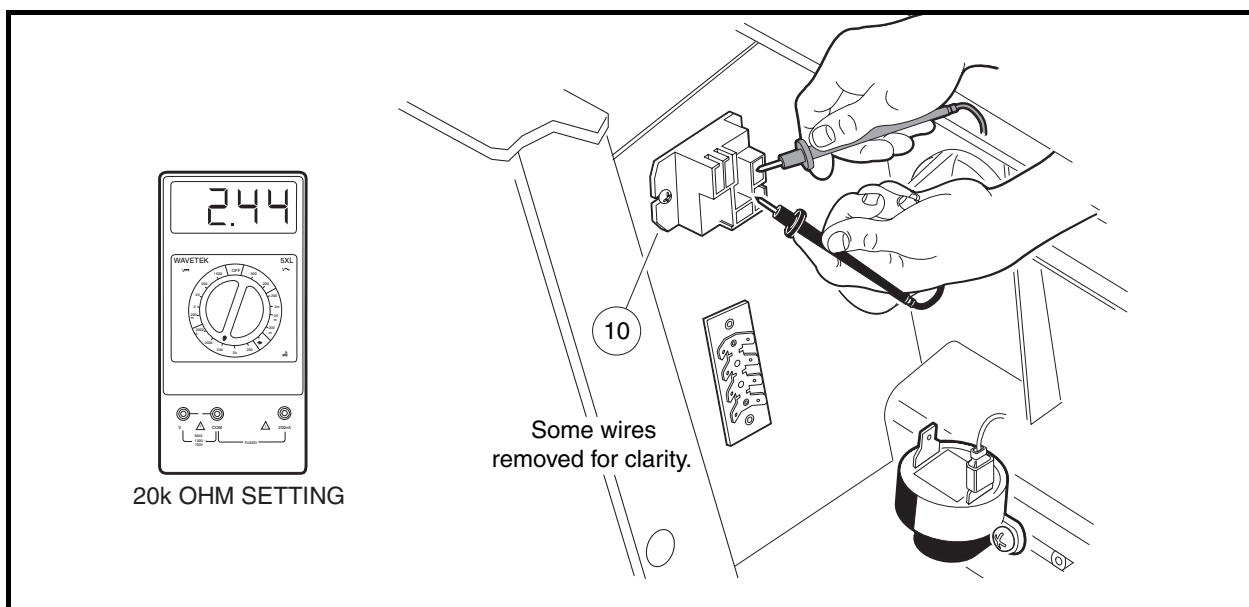


Figure 11-38 Brake Light Relay Coil Test

14. If a problem was not detected in the previous steps, check the following items:

- Battery voltage. **See Test Procedure 1 – Batteries / Voltage Check on page 11-16.**
- Continuity of all ground terminal block wires. **See Test Procedure 16 – Wire Continuity on page 11-30.**
- Voltage limiter. **See Test Procedure 20 – Voltage Limiter on page 11-37.**
- Taillight sockets. **See Test Procedure 22 – Taillight Bulb Socket on page 11-39.**
- Check taillight bulbs for continuity.
- Brake pedal limit switch. **See Test Procedure 24 – Brake Pedal Limit Switch on page 11-40.**
- Park brake pedal limit switch. **See Test Procedure 25 – Park Brake Pedal Limit Switch on page 11-41.**

For Turf 2 vehicle:

- Check the continuity of the yellow wire from the inline fuse holder to the light switch.
- Check the continuity of the fuse in the inline fuse holder on the yellow wire connected to the negative post of battery number 4.

For Carryall 6, TransPorter, Villager 6, and Villager 8 vehicles:

- Check the continuity of the red wire from the fuse block to the positive post of battery number 4.
- Check the continuity of the accessory fuse (located in the fuse block).

TEST PROCEDURE 20 – VOLTAGE LIMITER

See General Warning, Section 10, Page 10-1.

1. Place the Forward/Reverse handle in the NEUTRAL position, and chock the wheels.
2. Disconnect the battery cables as instructed. **See WARNING “To avoid unintentionally starting...” in General Warning, Section 10, Page 10-1.**
3. Remove the center dash assembly. **See step 2 of Key Switch Removal, Section 12, Page 12-1.**
4. Connect the battery cables, positive (+) cable first.
5. Using a multimeter set to 20 volts DC, place alligator clips on multimeter probes. Connect the black (–) probe to the terminal block under the front body (**Figure 11-32, Page 11-32**).
6. Connect the red (+) probe to the negative (–) post of battery number 4. To locate battery number 4, refer to the battery configuration figure. **See Figure 10-1, Section 10, Page 10-2.**
7. The voltage reading should be 15-17 volts.
8. Pull the light switch knob. Lights should illuminate and voltage should be 11-13 volts. If reading does not drop from 15-17 volts to 11-13 volts, replace the voltage limiter. **See Voltage Limiter Removal, Section 12, Page 12-17.**

TEST PROCEDURE 21 – VOLTAGE AT TAILLIGHT SOCKET (VEHICLES WITH TAIL-LIGHTS)

See General Warning, Section 10, Page 10-1.

1. Make sure the light switch is turned off before proceeding.
2. Check voltage at the taillight socket.
 - 2.1. Remove the taillight lens and remove the light bulb from the socket (**Figure 11-39, Page 11-39**).
 - 2.2. Using a multimeter set to 20 volts DC, place an alligator clip on the multimeter black probe. Connect the black (–) probe to the ground terminal (where the black wire is attached) on the back of the taillight assembly. **See following CAUTION.**

CAUTION

- **Do not allow the multimeter probe to touch the wire contact (+) and the metal housing (–) of the light bulb socket assembly at the same time. An electrical short circuit could occur which could blow the fuse or cause wire damage.**
- 2.3. To test the brake light circuit, place the red (+) probe on wire contact connected to the 18-gauge red wire.
 - 2.4. To test the taillight circuit, place the red (+) probe on wire contact connected to the 18-gauge brown wire.
 - 2.5. To test taillights, place light switch in the ON position and turn the key switch to the ON position. The reading should be approximately 12 volts.
 - 2.6. To test brake lights, place the light switch in the OFF position, place the key switch in the ON position, and press the brake pedal. The reading should be approximately 12 volts.
3. If a problem was detected in the previous steps, check the following items:
 - Battery voltage. **See Test Procedure 1 – Batteries / Voltage Check on page 11-16.**
 - Continuity of all ground terminal block wires. **See Test Procedure 16 – Wire Continuity on page 11-30.**
 - Voltage limiter. **See Test Procedure 20 – Voltage Limiter on page 11-37.**
 - Check taillight bulbs for continuity.
 - Brake pedal limit switch. **See Test Procedure 24 – Brake Pedal Limit Switch on page 11-40.**
 - Park brake pedal limit switch. **See Test Procedure 25 – Park Brake Pedal Limit Switch on page 11-41.**

For Turf 2 vehicle:

- Check the continuity of the yellow wire from the inline fuse holder to the light switch.
- Check the continuity of the fuse in the inline fuse holder on the yellow wire connected to the negative post of battery number 4.

For Carryall 6, TransPorter, Villager 6, and Villager 8 vehicles:

- Check the continuity of the red wire from the fuse block to the positive post of battery number 4.
- Check the continuity of the accessory fuse (located in the fuse block under the seat).

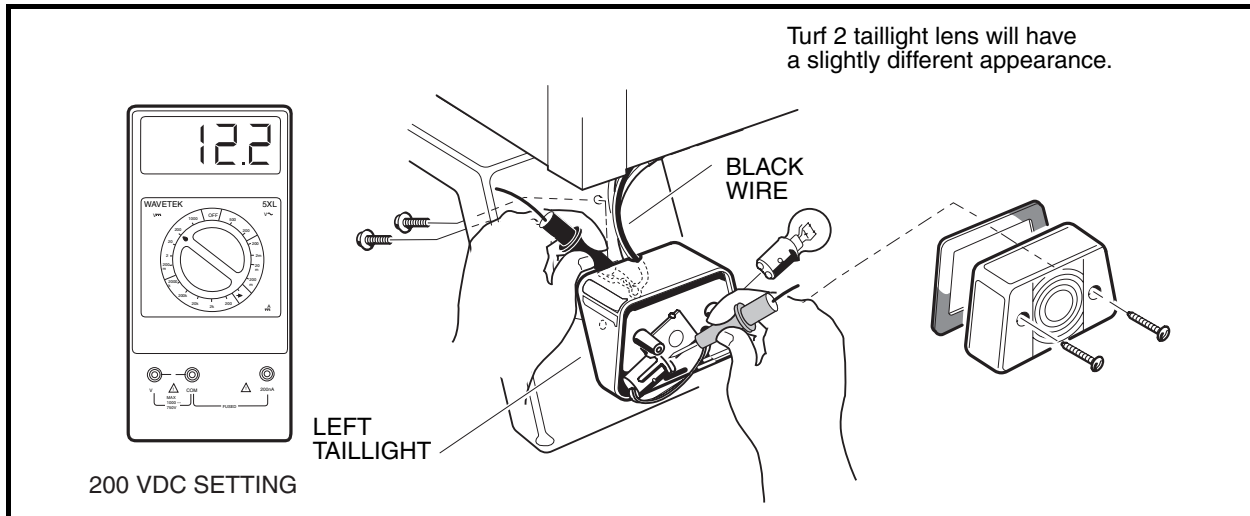


Figure 11-39 Taillight Socket Voltage Test

TEST PROCEDURE 22 – TAILLIGHT BULB SOCKET

See General Warning, Section 10, Page 10-1.

1. Inspect wires at the light bulb socket. Make sure wires are securely fastened to the contacts inside the socket (**Figure 11-39, Page 11-39**).
2. Inspect the socket housing to make sure there is no corrosion on the contacts or inside the housing.
3. Inspect the light bulb and make sure there is no corrosion on the bulb contacts.

TEST PROCEDURE 23 – VOLTAGE AT HEADLIGHT SOCKET

See General Warning, Section 10, Page 10-1.

1. Make sure the light switch is turned off before proceeding.
2. Check voltage at the headlight socket.
 - 2.1. Inspect wires at the headlight socket. Make sure wires are securely fastened to the contacts inside the socket.
 - 2.2. Disconnect the wire harness from the headlight (**Figure 11-40, Page 11-39**).

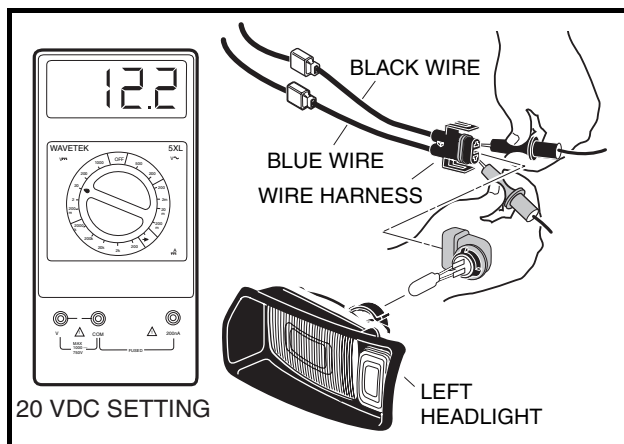


Figure 11-40 Headlight Socket Voltage Test

Test Procedure 23 – Voltage at Headlight Socket, Continued:

- 2.3. Set a multimeter to 20 volts DC. Place the black (–) probe into the black wire terminal of the wire harness. Place the red (+) probe into the blue wire terminal.
 - 2.4. Turn the key switch to the ON position and pull the light switch to the on position. If the multimeter indicates approximately 12 volts, replace the headlight bulb.
 - 2.5. If there is no voltage reading at the wire harness, check the continuity of the 16-gauge blue wire from the headlight to the light switch.
 - 2.6. Check continuity of the 16-gauge black wire from the headlight to the ground terminal.
3. If a problem was detected in the previous steps, check the following items:
- Battery voltage. **See Test Procedure 1 – Batteries / Voltage Check on page 11-16.**
 - Continuity of all ground terminal block wires. **See Test Procedure 16 – Wire Continuity on page 11-30.**
 - Voltage limiter. **See Test Procedure 20 – Voltage Limiter on page 11-37.**

For Turf 2 vehicle:

- Check the continuity of the yellow wire from the inline fuse holder to the light switch.
- Check the continuity of the fuse in the inline fuse holder on the yellow wire connected to the negative post of battery number 4.

For Carryall 6, TransPorter, Villager 6, and Villager 8 vehicles:

- Check the continuity of the red wire from the fuse block to the positive post of battery number 4.
- Check the continuity of the accessory fuse (located in the fuse block under the seat).

TEST PROCEDURE 24 – BRAKE PEDAL LIMIT SWITCH**See General Warning, Section 10, Page 10-1.**

1. Place the Forward/Reverse handle in the NEUTRAL position, and chock the wheels.
2. Disconnect the battery cables as instructed. **See WARNING “To avoid unintentionally starting...” in General Warning, Section 10, Page 10-1.**
3. Set a multimeter to 200 ohms and place alligator clips on the multimeter probes. Place the probes onto the two terminal screws on the limit switch located under the floorboard (**Figure 11-41, Page 11-41**).
4. With the brake pedal released, the multimeter should indicate no continuity (**Figure 11-41, Page 11-41**).
5. With the brake pedal pressed, the multimeter should indicate continuity (**Figure 11-42, Page 11-41**).
6. If the readings are incorrect, check continuity of the brake pedal limit switch wires.
7. Make sure the limit switch bracket is properly adjusted.
8. If wire continuity is correct and the switch continuity readings are incorrect, replace the switch. **See Brake Pedal Limit Switch Removal, Section 12, Page 12-18.**

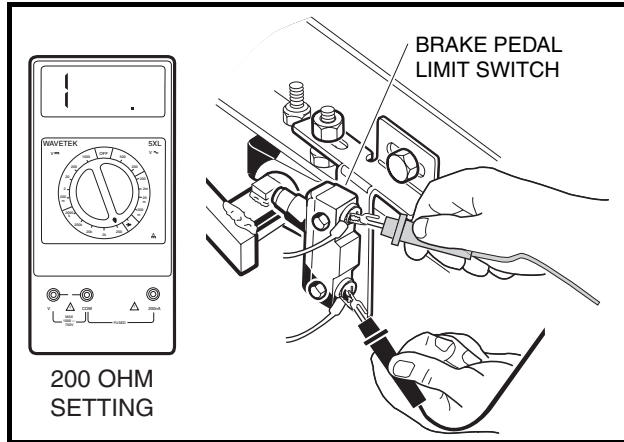


Figure 11-41 Brake Light Limit Switch Test – Brake Pedal Up

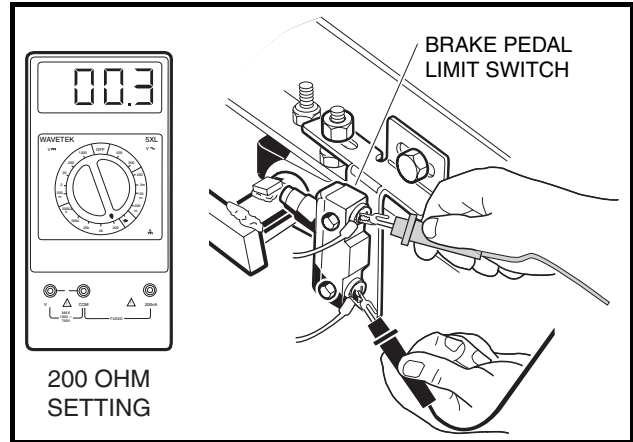


Figure 11-42 Brake Light Limit Switch Test – Brake Pedal Down

TEST PROCEDURE 25 – PARK BRAKE PEDAL LIMIT SWITCH

See General Warning, Section 10, Page 10-1.

1. Place the Forward/Reverse handle in the NEUTRAL position, and chock the wheels.
2. Disconnect the battery cables as instructed. See **WARNING “To avoid unintentionally starting...”** in General Warning, Section 10, Page 10-1.
3. Set a multimeter to 200 ohms and place alligator clips on the multimeter probes. Place the probes onto the two terminal screws on the limit switch located on the brake pedal (**Figure 11-43, Page 11-41**).
4. With the park brake pedal released, the multimeter should indicate no continuity (**Figure 11-43, Page 11-41**).

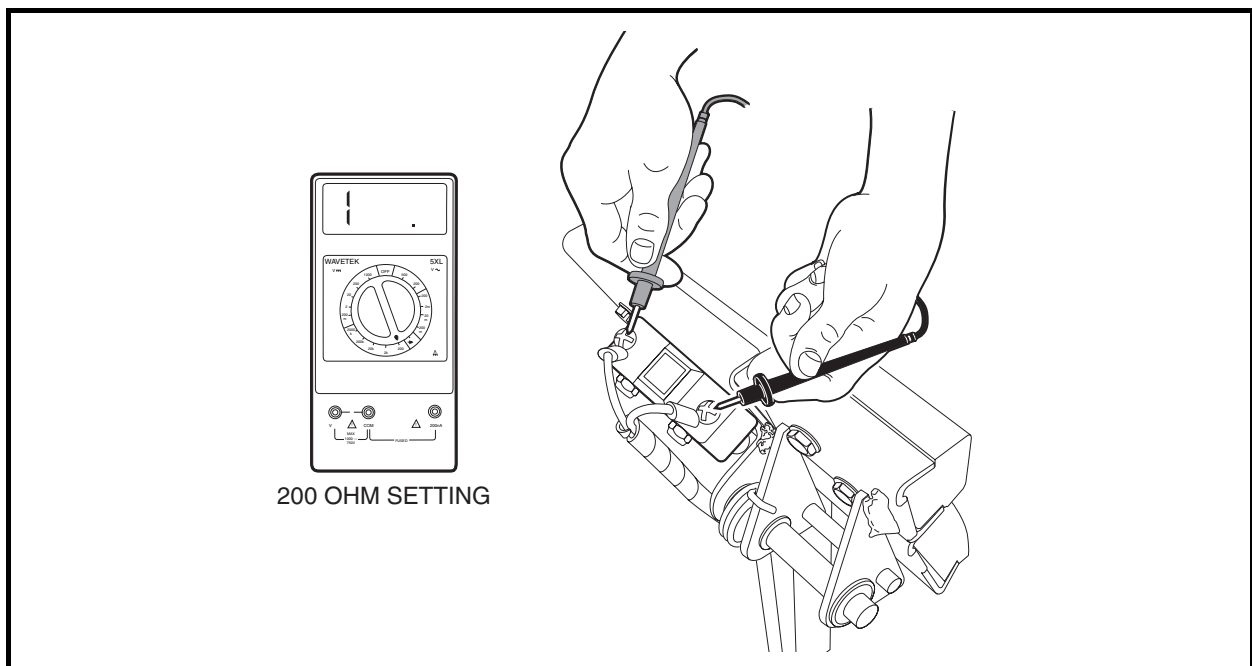


Figure 11-43 Park Brake Pedal Limit Switch Test – Park Brake Not Engaged

Test Procedure 25 – Park Brake Pedal Limit Switch, Continued:

5. With the park brake pedal engaged and locked, the multimeter should indicate continuity (**Figure 11-44, Page 11-42**).
6. If the readings are incorrect, check continuity of the park brake pedal limit switch wires.
7. Make sure the limit switch is properly adjusted.
8. If wire continuity is correct and the switch continuity readings are incorrect, replace the switch. **See Park Brake Pedal Limit Switch Removal, Section 12, Page 12-19.**

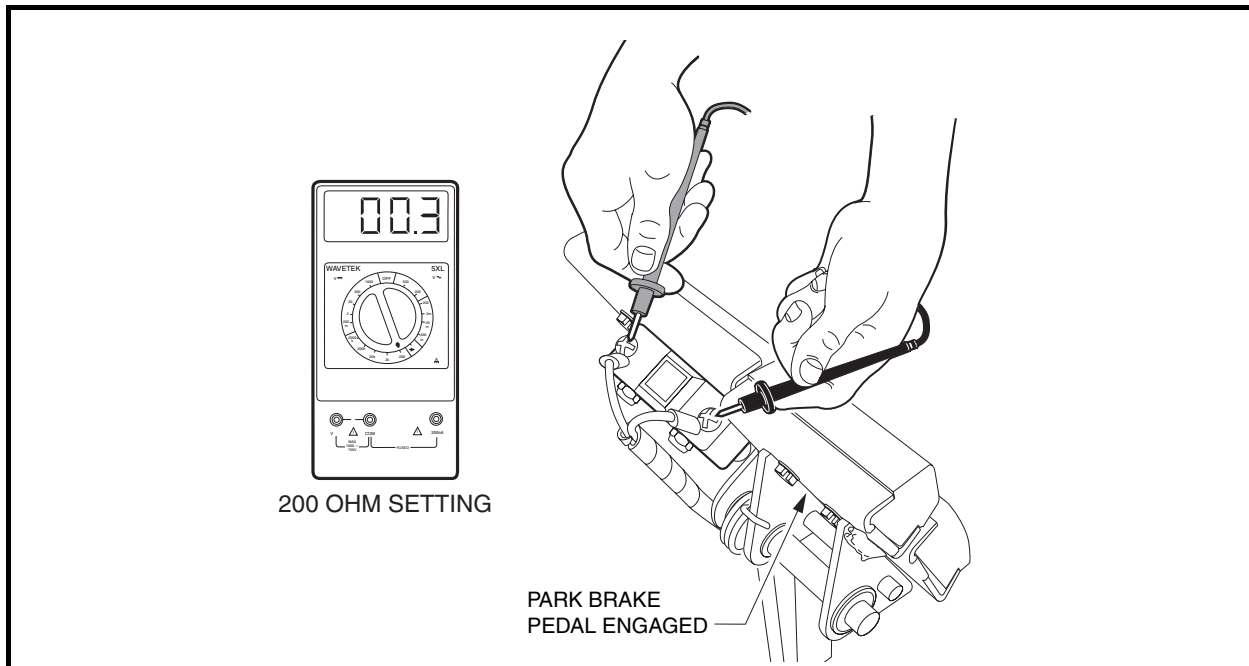


Figure 11-44 Park Brake Pedal Limit Switch Test – Park Brake Engaged

TEST PROCEDURE 26 – HORN SWITCH

See General Warning, Section 10, Page 10-1.

1. Place the Forward/Reverse handle in the NEUTRAL position, and chock the wheels.
2. Disconnect the battery cables as instructed. **See WARNING “To avoid unintentionally starting...” in General Warning, Section 10, Page 10-1.**
3. Disconnect the two-pin connector at the horn button from the wire harness.
4. Set a multimeter to 200 ohms. Place the probes into the two terminal plug holes in the horn switch wire harness (**Figure 11-45, Page 11-43**).
5. The multimeter should indicate no continuity. With the horn button pressed, the multimeter should indicate continuity.
6. If the readings are incorrect, replace the horn switch. **See Horn Switch Removal, Section 12, Page 12-24.**

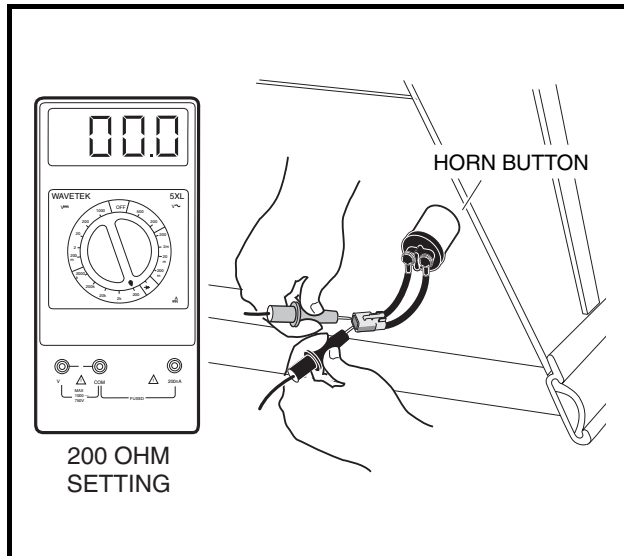


Figure 11-45 Horn Switch Test

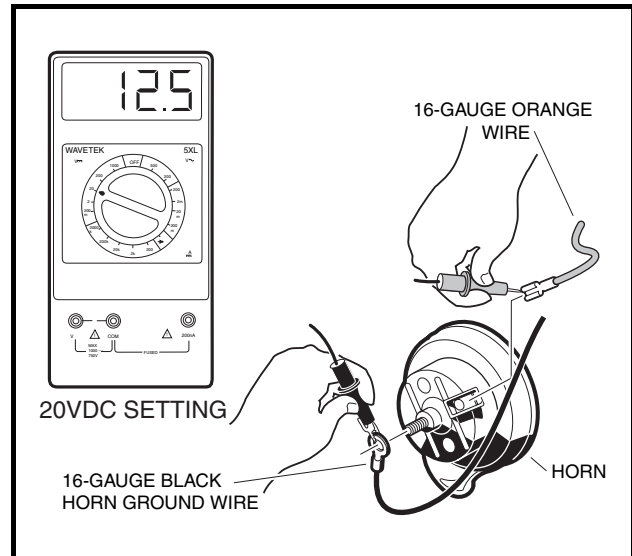


Figure 11-46 Horn Voltage Test

TEST PROCEDURE 27 – VOLTAGE AT HORN

See General Warning, Section 10, Page 10-1.

NOTE: Perform Test Procedure 26 – Horn Switch before performing the following test procedure.

1. Place the Forward/Reverse handle in the NEUTRAL position, and chock the wheels.
2. Disconnect the battery cables as instructed. See **WARNING “To avoid unintentionally starting...”** in **General Warning, Section 10, Page 10-1.**
3. Remove the center dash assembly. See **step 2 of Key Switch Removal, Section 12, Page 12-1.**
4. Disconnect the wires from the horn terminals.
5. Set a multimeter to 20 volts DC and place alligator clips on the multimeter probes. Connect the black (–) probe to the black horn ground wire (**Figure 11-46, Page 11-43**).
6. Connect the red (+) probe to the orange horn wire.
7. Connect the battery cables, positive (+) cable first.
8. The multimeter should indicate zero volts DC.
9. Press the horn button. The reading should be 15-17 volts DC.
10. If the readings are incorrect, check the continuity of the wires, the horn button, and fuse. If the readings are correct, replace the horn. See **Horn Removal, Section 12, Page 12-23.**

TEST PROCEDURE 28 – BATTERY CONDITION INDICATOR

See General Warning, Section 10, Page 10-1.

1. Place the Forward/Reverse handle in the NEUTRAL position, and chock the wheels.
2. Disconnect the battery cables as instructed. See **WARNING “To avoid unintentionally starting...”** in **General Warning, Section 10, Page 10-1.**
3. Remove the center dash assembly. See **step 2 of Key Switch Removal, Section 12, Page 12-1.**
4. Disconnect the wires from the battery condition indicator.

Test Procedure 28 – Battery Condition Indicator, Continued:

5. Set a multimeter to 200 volts DC. Place an alligator clip on the black (–) probe. Connect the black (–) probe to the 18-gauge black wire terminal. Place an alligator clip on the red (+) probe. Place the red (+) probe on the red wire.
6. Connect the battery cables, positive (+) cable first.
7. With the Forward/Reverse switch in the NEUTRAL position, turn the key switch to the ON position.
8. The multimeter should indicate 48 volts (full battery voltage). If the multimeter does not indicate full battery voltage, check the continuity of the black and red wires that power the battery condition indicator.
9. If the multimeter indicates full battery voltage, and the battery condition indicator does not function, replace the battery condition indicator. **See Battery Condition Indicator Removal, Section 12, Page 12-3.**

TEST PROCEDURE 29 – HOUR METER**See General Warning, Section 10, Page 10-1.**

1. Inspect the hour meter for proper operation.
 - 1.1. Remove the seat and note the reading on the hour meter.
 - 1.2. Drive the vehicle at a safe speed in a location where the accelerator pedal can remain pressed for at least 6 minutes. **See following NOTE.**
 - 1.3. In order for the reading on the hour meter to increment, the solenoid must be activated for 6 minutes or more.
 - 1.4. Bring the vehicle to a stop on a flat surface and firmly engage the park brake.
 - 1.5. Place the Forward/Reverse switch in the NEUTRAL position and remove the key from the key switch.
 - 1.6. Remove the seat and compare the reading on the hour meter to the reading noted in step 1.1.
 - 1.7. If the reading is higher than the reading noted in step 1.1, the hour meter is operating correctly.
 - 1.8. If the reading is the same as the reading noted in step 1.1, the hour meter is not receiving the required operating voltage, or the hour meter has failed.
2. Check the voltage to the hour meter.
 - 2.1. Place the Forward/Reverse handle in the NEUTRAL position, and remove the key from the key switch.
 - 2.2. Chock the wheels.
 - 2.3. Remove the seat.
 - 2.4. Remove the red (25) and yellow (26) wires from the hour meter (**Figure 11-47, Page 11-45**).
 - 2.5. Set a multimeter to 200 volts DC. Place an alligator clip on the black (–) probe. Connect the black (–) probe to the 18-gauge red wire terminal (25). Place an alligator clip on the red (+) probe. Place the red (+) probe on the 18-gauge yellow wire terminal (26).
 - 2.6. The multimeter should indicate zero volts. If the multimeter indicates full battery voltage, the accelerator pedal limit switch or MCOR limit switch is out of adjustment.
 - 2.7. Make sure that the alligator clips are firmly secured to the hour meter wires.
 - 2.8. Install the seat with the multimeter probe wires routed so that they will emerge from the back, passenger side of the seat.
 - 2.9. Move the wheel chocks.
 - 2.10. Have a technician monitor the multimeter while an assistant drives the vehicle. **See following WARNING.**

⚠ WARNING

- The vehicle operator should not monitor the multimeter while the vehicle is in motion. A technician can monitor the multimeter while traveling as a passenger in the vehicle. Failure to heed this warning could result in severe personal injury or death.

- 2.11. While the accelerator pedal is pressed, the multimeter should indicate 48 volts DC (full battery voltage).
- 2.12. If the multimeter does not indicate full battery voltage while the accelerator pedal is pressed, check the continuity of the red (25) and yellow (26) wires and wire terminals.
- 2.13. If the multimeter indicates full battery voltage, but the hour meter does not increment, the hour meter has failed. **See Hour Meter Removal, Section 12, Page 12-25.**

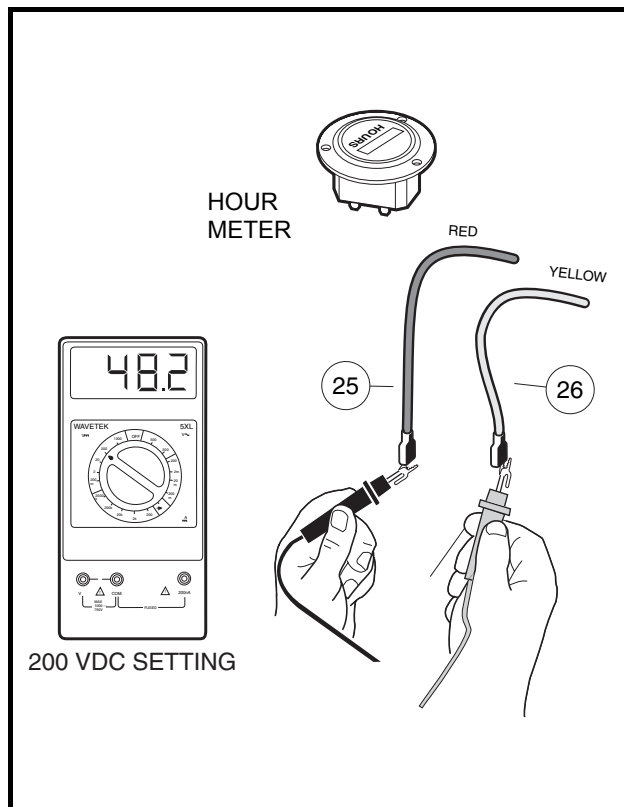


Figure 11-47 Hour Meter Voltage Test

COMMUNICATION DISPLAY MODULE (CDM)

The CDM can be used to retrieve from the onboard computer four important items of information that can be useful in troubleshooting the PowerDrive System 48 vehicle. To access one of these items, the item's corresponding Function Code must be selected on the CDM. This is done by pressing the Function Button until the desired function code is displayed in the window (**Figure 11-48, Page 11-46**). Releasing the button when the desired code is displayed will display the data. Function codes and corresponding data are as follows:

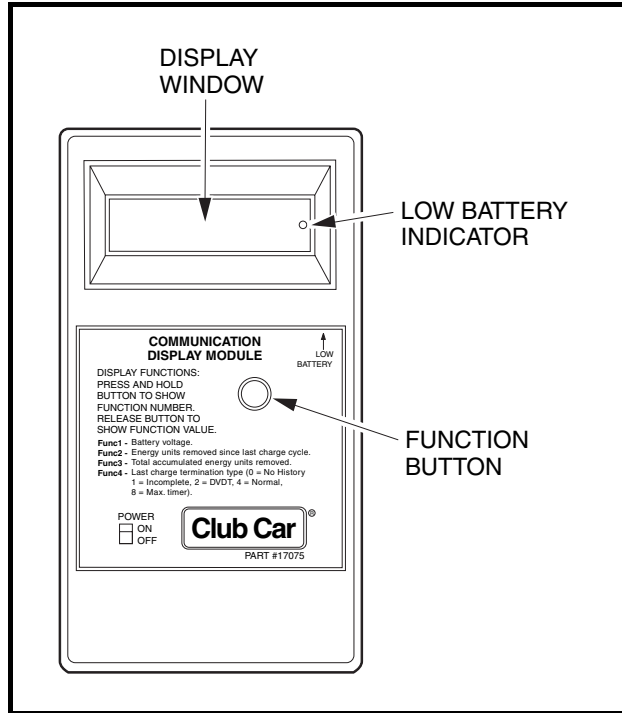


Figure 11-48 CDM

- **F1 – Battery voltage:**

This displays the battery pack's current state of charge. A reading of less than 48 volts indicates that the batteries need to be charged. If a reading of less than 48 volts is obtained immediately after a charge cycle, there may be a problem in the charge circuit.

- **F2 – Energy units removed since last charge cycle:**

If the display reads over 75 (the vehicle battery warning light should be illuminated), the vehicle batteries need to be recharged before being used again. This data can be used to make sure all vehicles in a fleet receive equal usage on a short-term basis.

- **F3 – Total accumulated energy units removed since initial vehicle start-up:**

This information is most useful in making sure that all vehicles in a fleet receive equal usage over long periods of time.

- **F4 – Last charge termination type (1 = incomplete, 2 = DVDT, 4 = normal, 8 = max. timer):**

A **1**, **2**, **4**, or **8** will be displayed.

1 – Indicates the last charge cycle was incomplete and the batteries were not fully charged. Batteries should be charged again at the earliest opportunity.

2 – Indicates a back-up charge program was employed by the OBC to complete the charge cycle. A DVDT charge may be displayed the first few times a new set of batteries is charged, and the first time a set of batteries is charged after the batteries have been disconnected and reconnected. A problem may exist if persistent DVDT readings are obtained.

4 – Indicates the last charge cycle was normal.

8 – Indicates the charger ran for sixteen hours and shut itself off without completing the charge cycle. This means there may be a problem in the charge circuit.

The CDM also has a low battery indicator, which illuminates when CDM batteries are weak and need to be replaced. Weak batteries in the CDM may cause the CDM to register inaccurate information or no information.

USING THE CDM TO RETRIEVE DATA FROM THE ONBOARD COMPUTER

1. Turn the CDM ON.
2. Position CDM on seat bottom so it is aligned directly with the battery warning light. Ensure CDM infrared LED receiver is pointed at battery warning light and there is a clear path between them. **See following NOTE.**

NOTE: *If, by positioning CDM on seat bottom, the CDM is unable to collect the data stream from the onboard computer, hold CDM approximately 6 inches (15.2 cm) from battery warning light.*

3. Wait approximately 30 seconds for a value to appear in the display window.
4. If a value does not appear in the display window after 30 seconds:
 - 4.1. Adjust aim of CDM.
 - 4.2. Drive vehicle a short distance to ensure OBC is not in powerdown mode.
 - 4.3. Check for weak batteries in CDM.
 - 4.4. If reading is still not obtained, go to the CDM Troubleshooting Guide on page 11-47.

Once a value has been obtained in the display window, the CDM may be removed from its receiving position and the data reviewed. The CDM will hold the values for F1, F2, F3, and F4 until the CDM is turned OFF or it receives another line of data from the same or another onboard computer. Use the following procedure to review the data stored in the CDM:

- The value currently displayed will be F1 (battery voltage).
- To view F2, press and hold the button on the CDM. When “Func 2” appears in the display window, release the button. The value for F2 will then be displayed.
- To view F3, press and hold the button on the CDM until “Func 3” appears in the display window. Release the button. The value for F3 will be displayed.
- To view F4, press and hold the button on the CDM until “Func 4” appears in the display window. Release the button. The value for F4 will be displayed. **See following NOTE.**

NOTE: *The values of all four functions can be recalled by pressing and releasing the CDM button.*

CDM TROUBLESHOOTING GUIDE

Use the chart on the following page as a starting point for troubleshooting problems with communication between the CDM and onboard computer. Contact your Club Car representative for more comprehensive information.

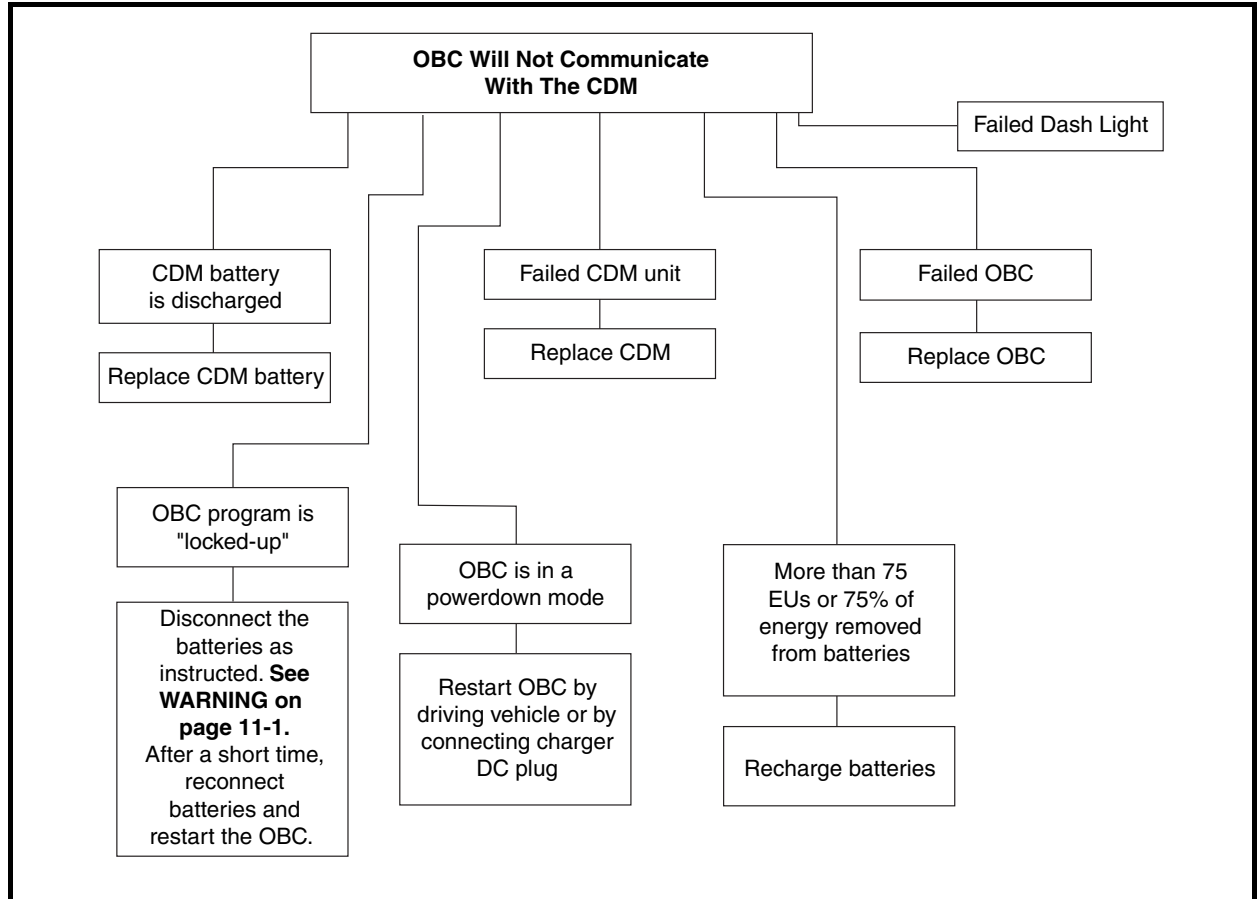


Figure 11-49 Flow Chart – CDM Troubleshooting Guide

SECTION 12 – ELECTRICAL COMPONENTS

⚠ DANGER

- See General Warning, Section 10, Page 10-1.

⚠ WARNING

- See General Warning, Section 10, Page 10-1.

KEY SWITCH

See General Warning, Section 10, Page 10-1.

Testing the Key Switch

See Test Procedure 2, Section 11, Page 11-16.

Key Switch Removal

1. Disconnect the battery cables as instructed. **See WARNING “To avoid unintentionally starting...” in General Warning, Section 10, Page 10-1.**
2. Remove the center dash panel.
 - 2.1. Remove the plastic cap (1) covering the mounting screw (2) on each side of the center dash panel (3) (**Figure 12-1, Page 12-1**).
 - 2.2. Loosen, but do not remove, the screw (2) on each side of the center dash panel (3).
 - 2.3. Insert screwdriver at the top center of the dash between dash and cowl brace. Gently pry center dash out from under edge of cowl brace.

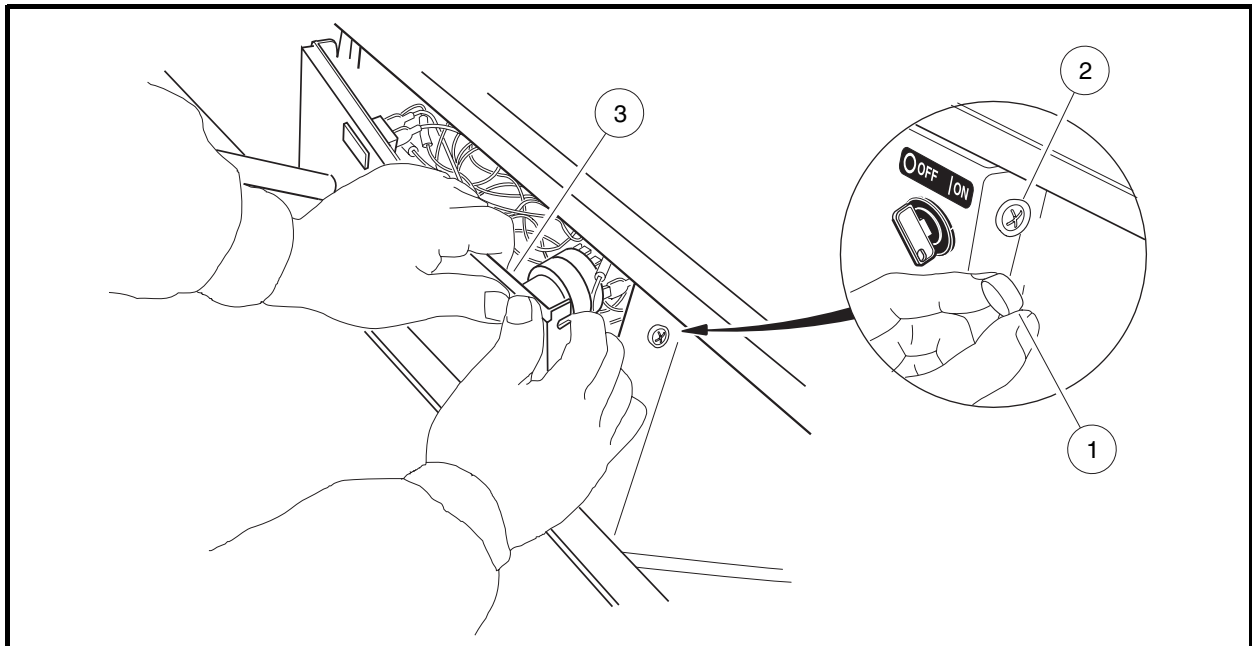


Figure 12-1 Dash Removal

Key Switch Removal, Continued:

- 2.4. Pull center dash out approximately 1 inch (2.5 cm) from the frame and then bend the top right corner of the center dash panel inward while pulling the top of the panel out and down. **See following NOTE.**

NOTE: Bending the top right corner of the center dash inward during removal will prevent the terminals (7) on the back of the key switch from touching the metal frame around the dash (**Figure 12-1, Page 12-1**).

- 2.5. Slide center dash panel up steering column by snapping top out and then rotating the panel out and up.
3. Disconnect the wires from the key switch. Do not allow wires to touch.
4. From the back of the dash panel, push down on the retaining tabs surrounding the key switch (4) and remove the key switch cap (8). Hold the key switch and remove the switch retaining nut (6) from the outside of the dash panel (**Figure 12-2, Page 12-2**).

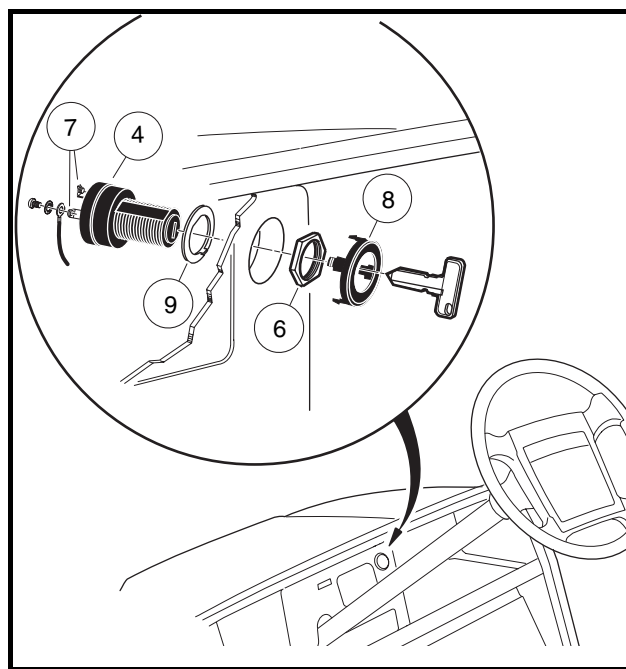


Figure 12-2 Key Switch

Key Switch Installation

1. Position the key switch and flat washer (9) in the center dash, then install and tighten the switch retaining nut (6) to 40 in-lb (4.5 N·m). Install key switch cap (8) in center dash (**Figure 12-2, Page 12-2**).
2. Using the wiring diagram, connect the wires to the key switch terminals and tighten the terminal screws to 7 in-lb (0.8 N·m). **See Wiring Diagrams, Section 11, Page 11-2.** Coat the terminals with Battery Terminal Protector Spray (CCI P/N 1014305).
3. Install center dash by reversing removal procedure. Make sure key switch terminals (7) do not touch frame and that the center dash panel is properly seated and snapped into place (**Figure 12-2, Page 12-2**).
4. Connect the battery cables, positive (+) cable first. Tighten battery terminals to 110 in-lb (12.4 N·m) and coat terminals with Battery Terminal Protector Spray (CCI P/N 1014305) to minimize corrosion.

BATTERY CONDITION INDICATOR

See General Warning, Section 10, Page 10-1.

Testing the Battery Condition Indicator

See Test Procedure 28, Section 11, Page 11-43.

Battery Condition Indicator Removal

1. Disconnect the battery cables as instructed. See **WARNING “To avoid unintentionally starting...”** in **General Warning, Section 10, Page 10-1.**
2. Remove the center dash assembly. See **step 2 of Key Switch Removal on page 12-1.**
3. Remove the red wire from terminal 1 of the battery condition indicator.
4. Remove the black wire from terminal 2 of the battery condition indicator.
5. Use a small flat-head screwdriver to gently pry the push nuts securing the battery condition indicator to the center dash assembly.
6. Remove the battery condition indicator from the center dash assembly.

Battery Condition Indicator Installation

1. Insert the battery condition indicator into the hole in the center dash assembly.
2. Secure the battery condition indicator with two push nuts.
3. Connect the black wire to terminal 2 of the battery condition indicator.
4. Remove the red wire to terminal 1 of the battery condition indicator.
5. Install the center dash assembly.
6. Connect the battery cables, positive (+) cable first. Tighten battery terminals to 110 in-lb (12.4 N·m) and coat terminals with Battery Terminal Protector Spray (CCI P/N 1014305) to minimize corrosion.

FORWARD/REVERSE SWITCH

See General Warning, Section 10, Page 10-1.

DANGER

- Turn the key to OFF, put the Forward/Reverse handle in NEUTRAL, disconnect the battery cables as shown and discharge the controller as instructed. See **WARNING “To avoid unintentionally starting...”** in **General Warning, Section 10, Page 10-1.** Failure to do so may cause the vehicle to run over you, resulting in severe injury or death.

Testing the Forward/Reverse Switch

See Test Procedure 5, Section 11, Page 11-19.

Forward/Reverse Switch Inspection

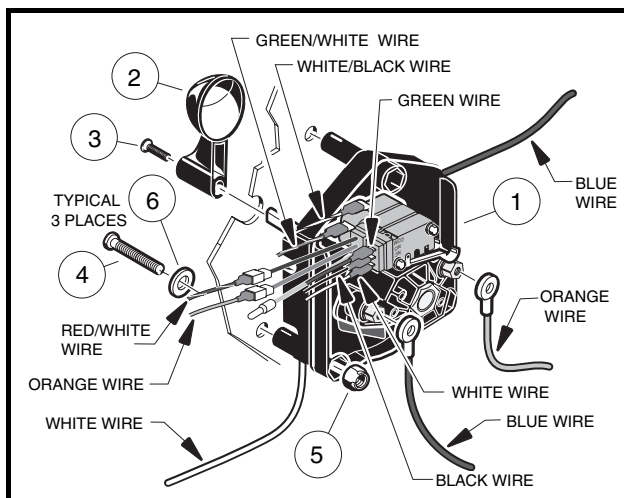
Visually inspect rotor and contacts; be sure contacts are in good condition. If they are not, replace the Forward/Reverse switch. If the switch is hard to turn or sticks, a light spray of WD-40® may be applied to the contacts and shaft. See following **WARNING.** If severe arcing has occurred, check Forward/Reverse anti-arcing limit switch for proper operation. See **Test Procedure 3, Section 11, Page 11-17.**

Forward/Reverse Switch Inspection, Continued:**⚠ WARNING**

- Do not grease contacts. This could cause the Forward/Reverse switch to malfunction or burn.

Forward/Reverse Switch Removal

1. Disconnect the battery cables as instructed. **See WARNING “To avoid unintentionally starting...” in General Warning, Section 10, Page 10-1.**
2. Remove the Forward/Reverse handle mounting screw (3) and handle (2) (**Figure 12-3, Page 12-4**).
3. Disconnect 18-gauge wires from limit switches. Remove two 6-gauge wires from back of Forward/Reverse switch.
4. Remove the screws (4), plastic washers (6) (if present), and nuts (5) that mount the Forward/Reverse switch to the body.
5. Pull the Forward/Reverse switch away from the body. Remove the 6-gauge wires from the front of the Forward/Reverse switch and then remove switch from the battery compartment for ease of service.

**Figure 12-3 Forward/Reverse Switch Wiring****Forward/Reverse Switch Installation**

1. Connect the 6-gauge wires to the front of the Forward/Reverse switch and tighten nuts to 45 in-lb (5.1 N·m). **See following WARNING.**
2. Secure Forward/Reverse switch to vehicle body by using existing hardware, and tighten screws:
 - 64 in-lb (7.2 N·m) for Carryall 1 vehicles
 - 33 in-lb (3.7 N·m) for all other vehicles
3. Connect the two 6-gauge wires to the back of the Forward/Reverse switch and tighten the screws to 27 in-lb (3.0 N·m).
4. Connect the 18-gauge wires to the limit switches. **See following WARNING and CAUTION.**
5. Place handle (2) on the Forward/Reverse switch. Tighten screw (3) to 14 in-lb (1.6 N·m) (**Figure 12-3, Page 12-4**).

⚠ WARNING

- Make sure wires are properly connected to Forward/Reverse switch. If wires are not properly connected, the vehicle may operate in an unexpected manner, resulting in property damage, severe injury or death. See Wiring Diagrams, Section 11, Page 11-2.

CAUTION

- Be sure the wires are routed so the wire from the Forward/Reverse rotor does not pull on other wires when the Forward/Reverse handle is shifted.

6. Connect the battery cables, positive (+) cable first. Tighten battery terminals to 110 in-lb (12.4 N·m) and coat terminals with Battery Terminal Protector Spray (CCI P/N 1014305) to minimize corrosion.

FORWARD/REVERSE LIMIT SWITCHES

The Forward/Reverse anti-arcing limit switch, reverse buzzer limit switch, and half-speed reverse limit switch are located on the Forward/Reverse switch and are activated by a cam on the Forward/Reverse switch rotor (Figure 12-4, Page 12-5).

Testing the Limit Switches

- Forward/Reverse Anti-Arcing Limit Switch: See Test Procedure 3, Section 11, Page 11-17.
- Reverse Buzzer Limit Switch: See Test Procedure 14, Section 11, Page 11-29.
- Half-Speed Reverse Limit Switch: See Test Procedure 12, Section 11, Page 11-27.

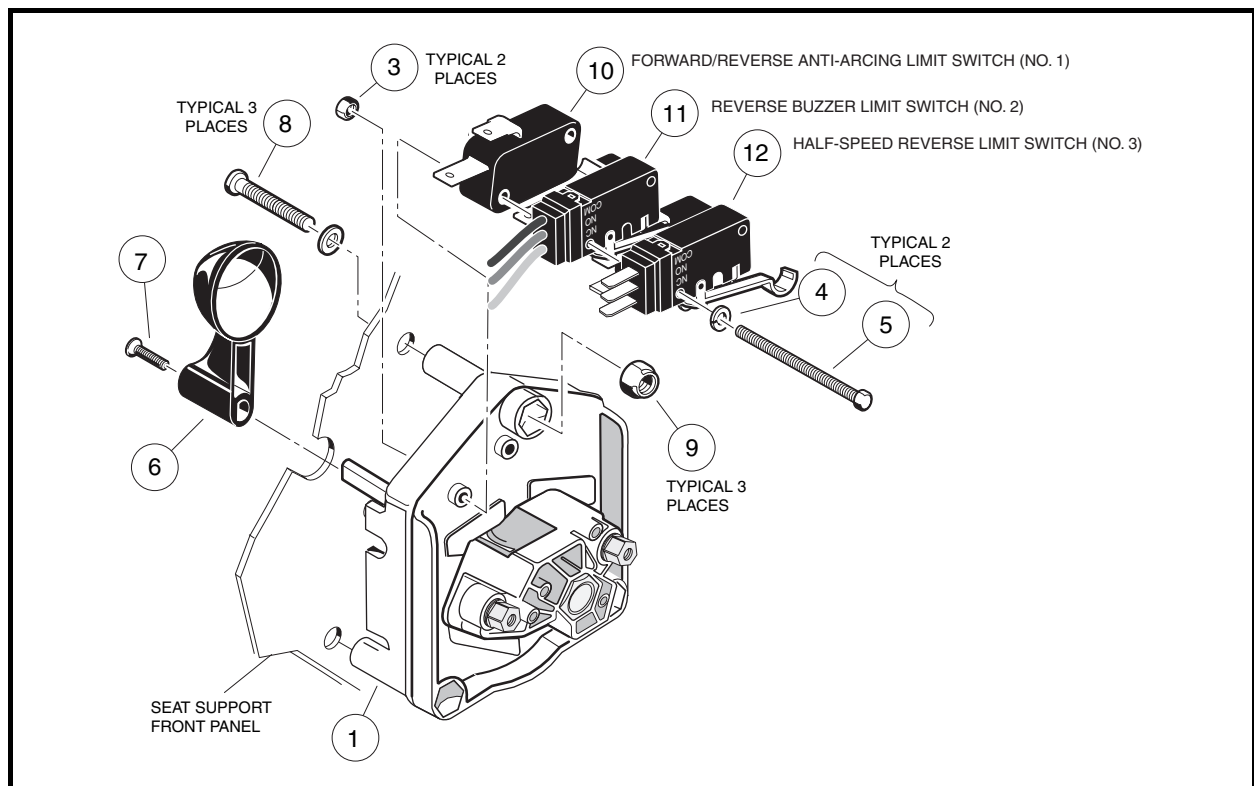


Figure 12-4 Forward/Reverse Switch

Limit Switch Removal

1. Disconnect the battery cables as instructed. **See WARNING “To avoid unintentionally starting...” in General Warning, Section 10, Page 10-1.**
2. Remove all three limit switches from Forward/Reverse switch by removing two screws (5), lockwashers (4), and nuts (3). Label each wire prior to disconnecting wire terminals from each switch (**Figure 12-4, Page 12-5**).

Limit Switch Installation

1. Install in reverse order of disassembly. Insert labeled wires onto limit switch terminals as designated. Tighten screws to 5 in-lb (0.6 N·m). **See following CAUTION.** If wires were not labeled during removal, refer to the wiring diagram for proper wiring. **See Wiring Diagrams, Section 11, Page 11-2.**

CAUTION

- **Do not overtighten the retaining nuts. If the nuts are overtightened, limit switches could be damaged.**
2. Connect the battery cables, positive (+) cable first. Tighten battery terminals to 110 in-lb (12.4 N·m) and coat terminals with Battery Terminal Protector Spray (CCI P/N 1014305) to minimize corrosion.
 3. After installation, be sure when the rotor is turned, the actuator arm of each switch is pressed and released per chart on next page. If not correct, inspect the Forward/Reverse rotor and limit switches for damage.

FORWARD/REVERSE HANDLE POSITION	ANTI-ARCING LIMIT SWITCH	HALF SPEED LIMIT SWITCH	REVERSE BUZZER LIMIT SWITCH
FORWARD	Activated	Released	Released
NEUTRAL	Released	Released	Released
REVERSE	Activated	Activated	Activated

HALF-SPEED RESISTOR – TO HALF-SPEED REVERSE LIMIT SWITCH

The half-speed resistor assembly is connected to the half-speed reverse limit switch on the Forward/Reverse switch (**Figure 12-4, Page 12-5**).

Testing the Half-speed Reverse Resistor

See Test Procedure 13, Section 11, Page 11-28.

Half-speed Resistor Removal

1. Disconnect the battery cables as instructed. **See WARNING “To avoid unintentionally starting...” in General Warning, Section 10, Page 10-1.**
2. Disconnect the black and white wires on the no. 3 limit switch (**Figure 12-4, Page 12-5**).
3. Cut electrical tape at both ends of wire conduit and pull wire assembly with resistor out of wire conduit.
4. Use an 1/8-inch (3 mm) tip flat blade screwdriver to remove the rubber gasket from the plug housing (**Figure 12-5, Page 12-7**).
5. Place the flat blade of the screwdriver against the wedge lock at the recessed area and pry wedge lock from plug housing (**Figure 12-5, Page 12-7**).

6. Insert screwdriver into terminal under the clip and gently raise the clip and pull wire from housing (**Figure 12-5, Page 12-7**).

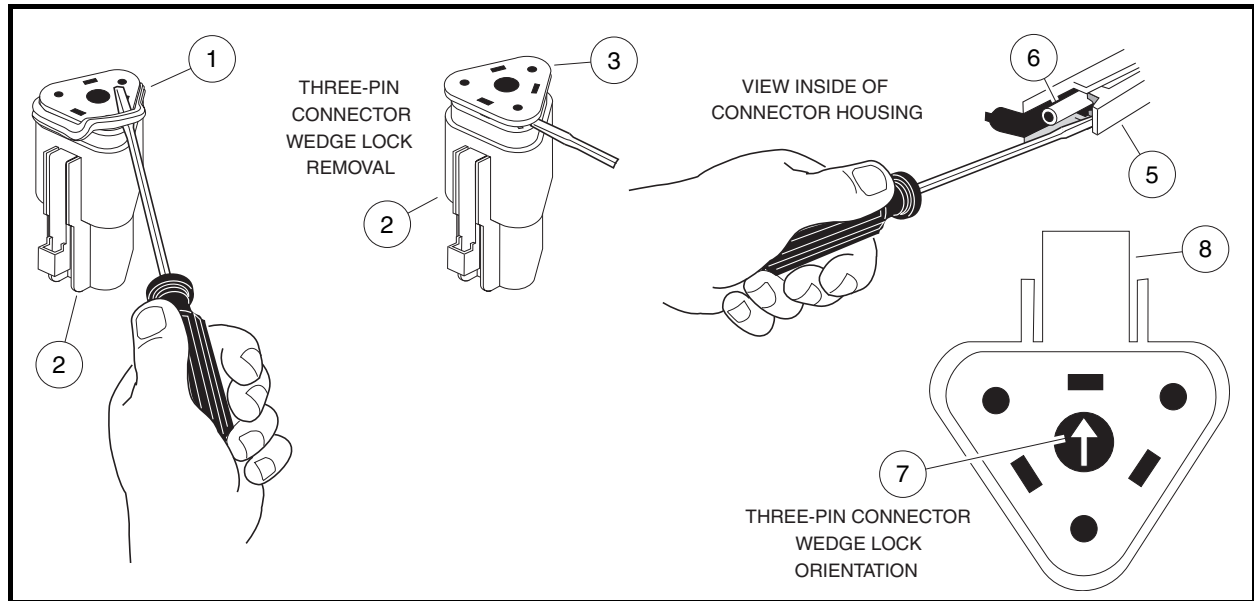


Figure 12-5 Terminal Plug Housing

Half-Speed Resistor Installation

1. Installation is reverse of removal. Make sure black/white wire is pushed securely into terminal plug housing and locked into place.
2. If using a three-pin connector, make sure wedge lock is positioned correctly with arrow on wedge lock pointing toward housing clip (**Figure 12-5, Page 12-7**).
3. Connect the battery cables, positive (+) cable first. Tighten battery terminals to 110 in-lb (12.4 N·m) and coat terminals with Battery Terminal Protector Spray (CCI P/N 1014305) to minimize corrosion.

REVERSE BUZZER

See General Warning, Section 10, Page 10-1.

The reverse buzzer is mounted on the back of the center dash panel, under the front body. An additional buzzer is mounted on the rear fender of the Carryall 6 and TransPorter vehicles and on the frame next to the rear fender on Villager 6 and 8 vehicles.

Testing the Reverse Buzzer

See Test Procedure 15, Section 11, Page 11-29.

Front Mounted Reverse Buzzer Removal

1. Disconnect the battery cables as instructed. See **WARNING “To avoid unintentionally starting...” in General Warning, Section 10, Page 10-1**.
2. Remove center dash. See **step 2 of Key Switch Removal on page 12-1**.
3. Disconnect the 18-gauge red and orange wires from reverse buzzer.
4. Remove the two screws from the reverse buzzer. Remove the reverse buzzer from the center dash panel.

Rear Mounted Reverse Buzzer Removal – Carryall 6, Villager 6 and 8 and Trans-Porter

1. Disconnect the battery cables as instructed. **See WARNING “To avoid unintentionally starting...” in General Warning, Section 10, Page 10-1.**
2. **Carryall 6 and TransPorter vehicles:** Remove two 1/4-inch x 4-inch bolts and nuts that secure bed to frame. Raise bed and secure prop rod in bed frame.
3. Disconnect the 18-gauge red and orange wires from the reverse buzzer and remove buzzer from vehicle.

Reverse Buzzer Installation

1. Install the reverse buzzer in the reverse order of removal. Install red wire to positive (+) terminal and orange wire to negative (–) terminal on buzzer. Tighten screws to 4 in-lb (0.45 N·m).
2. Connect the battery cables, positive (+) cable first. Tighten battery terminals to 110 in-lb (12.4 N·m) and coat terminals with Battery Terminal Protector Spray (CCI P/N 1014305) to minimize corrosion.

SOLENOID

See General Warning, Section 10, Page 10-1.

General Information

The solenoid is located on the electrical component mounting plate (**Figure 12-7, Page 12-9**).

The solenoid has two sets of electrical connectors: two 5/16-inch posts (power contact posts) and two terminals (activating coil connections) (**Figure 12-6, Page 12-8**).

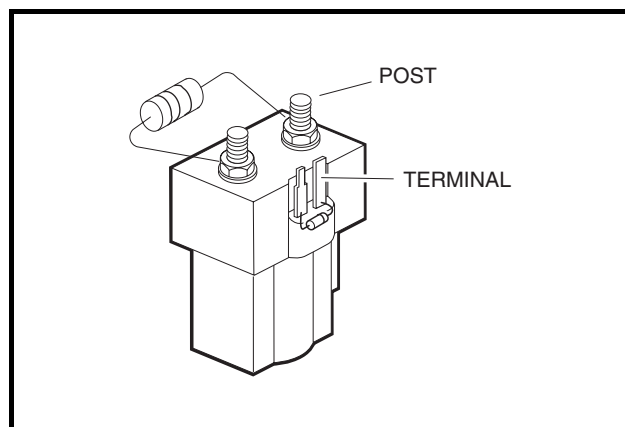


Figure 12-6 Diode Removal

Testing the Solenoid

See Test Procedure 6, Section 11, Page 11-20.

Solenoid Removal

1. Disconnect the battery cables as instructed. **See WARNING “To avoid unintentionally starting...” in General Warning, Section 10, Page 10-1.**
2. Disconnect all wires from solenoid. Remove resistor assembly (14) (**Figure 12-7, Page 12-9**).
3. Remove the two thread-rolling screws (10) and remove the solenoid (17).

Solenoid Installation

1. Install the solenoid onto the mounting plate and tighten screws (10) to 50 in-lb (5.7 N-m).
2. Connect wires to the solenoid. **See Wiring Diagrams, Section 11, Page 11-2.** Tighten hex nut (5) to 60 in-lb (6.7 N-m) (**Figure 12-7, Page 12-9**).
3. Install the resistor as shown in the appropriate wiring diagram. **See Wiring Diagrams, Section 11, Page 11-2.**
4. Connect the battery cables, positive (+) cable first. Tighten battery terminals to 110 in-lb (12.4 N-m) and coat terminals with Battery Terminal Protector Spray (CCI P/N 1014305) to minimize corrosion.

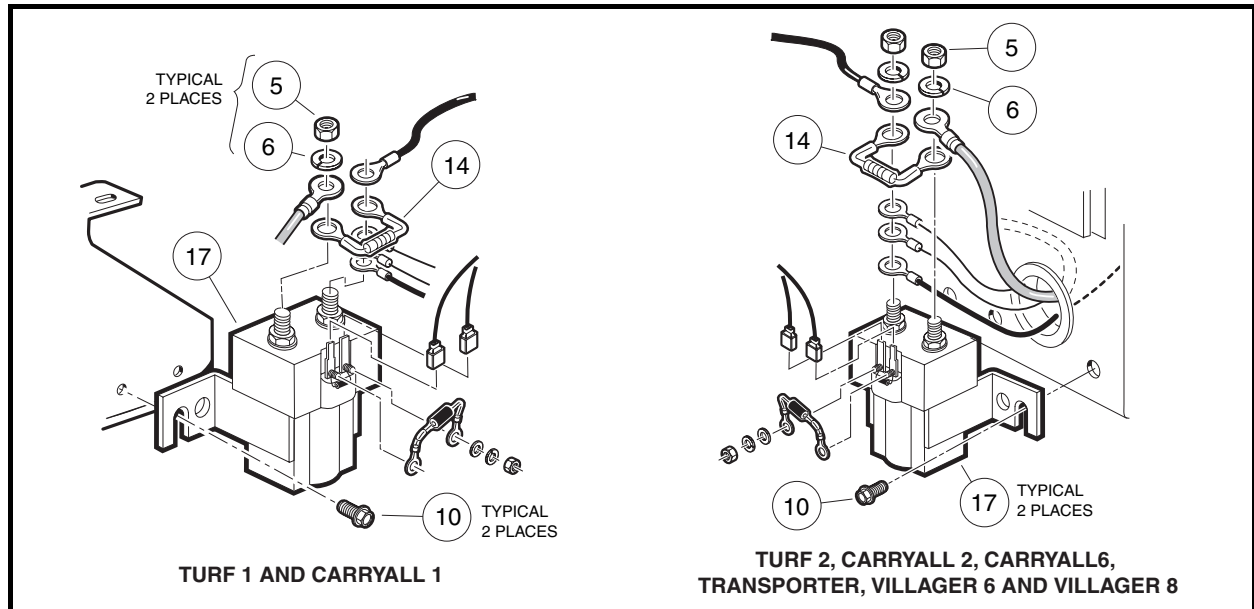


Figure 12-7 Solenoid Removal and Installation

DIODE – SOLENOID

A diode is placed across the solenoid activating coil to allow the field to collapse and prevent limit switch failures. If limit switches are failing, the diode should be checked.

Testing the Diode

See Test Procedure 4, Section 11, Page 11-18.

Diode Removal

The diode assembly is connected to the two small terminals (activating coil connections) on the solenoid.

1. Disconnect the battery cables as instructed. **See WARNING “To avoid unintentionally starting...” in General Warning, Section 10, Page 10-1.**
2. Remove the two small wire terminals from the solenoid.
3. The diode must be checked and found to be functioning correctly **before** the activating coil resistance can be accurately measured. The diode can **only** be tested using a continuity test light (CCI P/N 1011273).
 - 3.1. Place the probe end of the tester on the small terminal of the solenoid marked positive (+) and clip the wire on the other small activating coil terminal of the solenoid (**Figure 12-8, Page 12-10**). The tester should illuminate, indicating continuity.
 - 3.2. Reverse the positions of the probe and clip. The tester should not illuminate. If any other reading is obtained, the diode must be replaced. If the diode is functioning correctly, proceed to step 5.

Diode Removal, Continued:

- To remove the diode, carefully clip the two leads where they attach to the solenoid terminals (**Figure 12-8, Page 12-10 and Figure 12-9, Page 12-10**). See following **NOTE**.

NOTE: The diode must be functioning correctly before checking the resistance of the activating coil. In the case of a failed diode, the diode must be removed before the coil resistance can be checked.

- Place red (+) probe of the multimeter on the positive (+) solenoid terminal. Place the black (–) probe on the other small solenoid terminal. A reading of 180 to 190 ohms should be obtained. If not, replace the solenoid.
- If a failed diode was removed, replace the diode by installing a new diode assembly (CCI P/N 1014948), making sure that the red ring terminal of the replacement diode is connected to the positive (+) solenoid terminal.

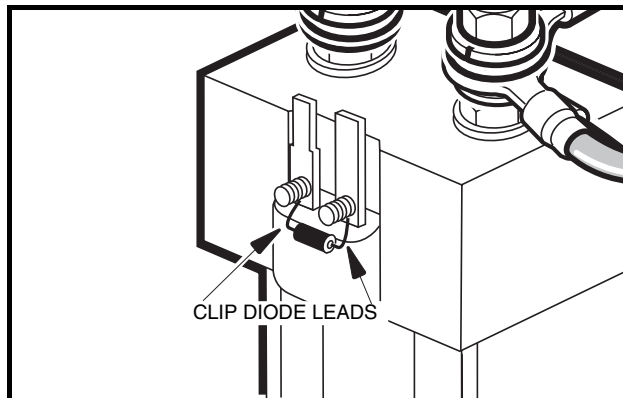


Figure 12-8 Diode Removal

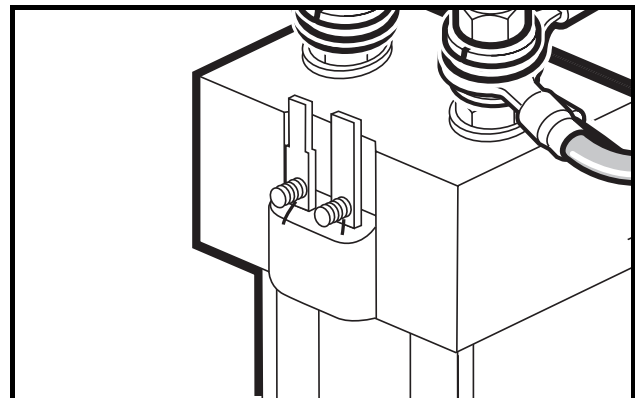


Figure 12-9 Solenoid with Diode Removed

RESISTOR – SOLENOID

A 250-ohm resistor is placed across the contacts to keep the capacitors in the solid state speed controller charged. This reduces arcing on the contacts of the solenoid. Whenever a solenoid fails or the 250-ohm resistor is discolored or changed in appearance, the resistor should be checked.

Testing the Resistor

See **Test Procedure 6, Section 11, Page 11-20**.

Resistor Removal

- Disconnect the battery cables as instructed. See **WARNING “To avoid unintentionally starting...”** in **General Warning, Section 10, Page 10-1**.
- Remove the two large nuts and lockwashers that attach the resistor to the solenoid.
- Remove the resistor from the solenoid.

Resistor Installation

- Install in reverse order of removal. Tighten large nuts attaching resistor to solenoid to 60 in-lb (6.7 N·m). See **Wiring Diagrams, Section 11, Page 11-2**.
- Connect the battery cables, positive (+) cable first. Tighten battery terminals to 110 in-lb (12.4 N·m) and coat terminals with Battery Terminal Protector Spray (CCI P/N 1014305) to minimize corrosion.

ONBOARD COMPUTER (OBC)

See General Warning, Section 10, Page 10-1.

Testing the Onboard Computer

See Test Procedure 9, Section 11, Page 11-26.

Onboard Computer Removal

1. Disconnect the battery cables as instructed. See **WARNING “To avoid unintentionally starting...”** in **General Warning, Section 10, Page 10-1.**
2. Disconnect 10-gauge black wire (23) from the back of charger receptacle (21) (**Figure 12-10, Page 12-11**).
3. Disconnect the gray wire (from OBC) at the fuse housing (9), leaving the sense lead fuse inserted into housing on the gray lead (3) from the charger receptacle (**Figure 12-10, Page 12-11**).

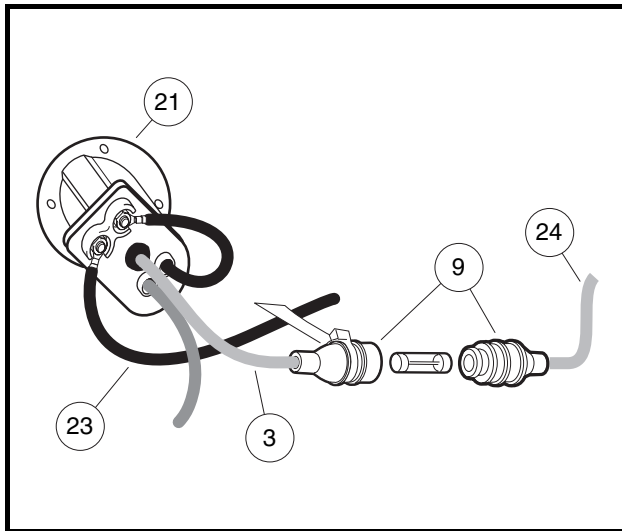


Figure 12-10 Charger Receptacle Wiring

4. Remove the 18-gauge red and yellow wires on the solenoid.
5. Disconnect 6 and 10-gauge black wires from B- terminal of the controller (11) (**Figure 12-11, Page 12-12 or Figure 12-12, Page 12-12**).
6. Disconnect the three-pin connector (18) at the OBC (15) (**Figure 12-11, Page 12-12 or Figure 12-12, Page 12-12**).
7. Loosen, but do not remove, two 1/4 thread-rolling screws (10) holding OBC to the component mounting plate (1) (**Figure 12-11, Page 12-12 or Figure 12-12, Page 12-12**).
8. **Turf 1 and Carryall 1 vehicles:** Slide the OBC to the left and remove OBC from mounting plate.

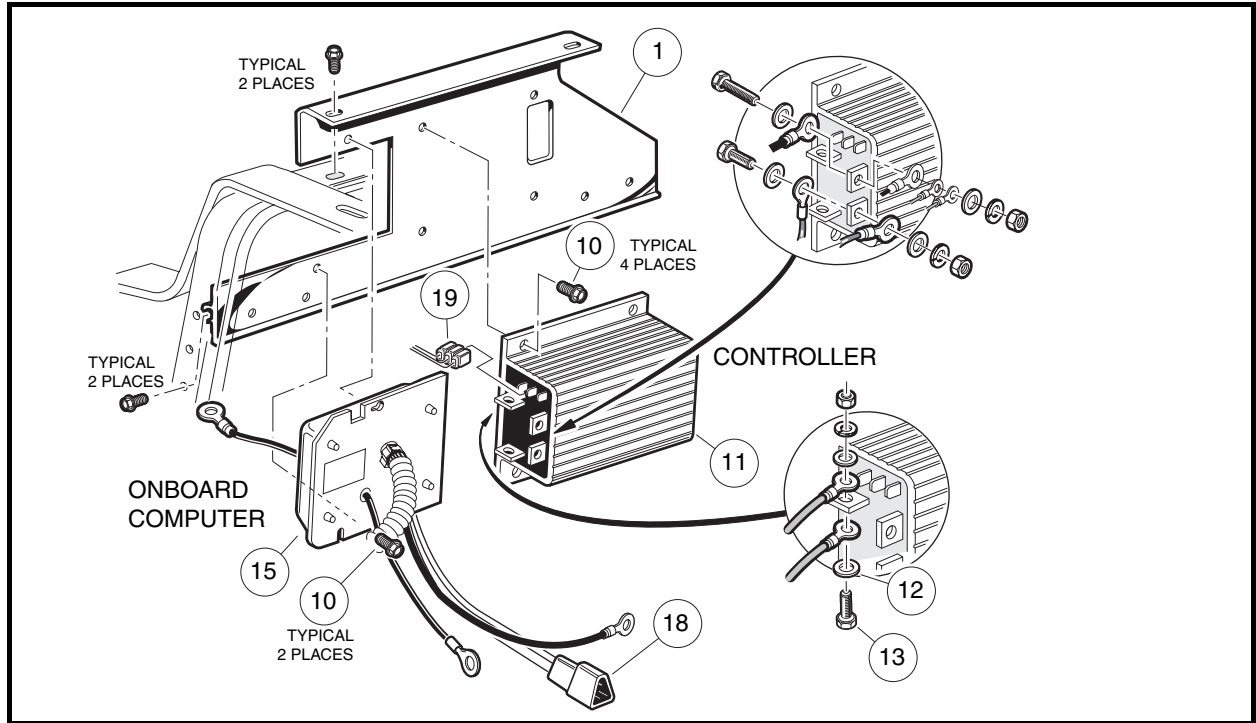


Figure 12-11 Controller and Onboard Computer – Turf 1 and Carryall 1 Vehicles

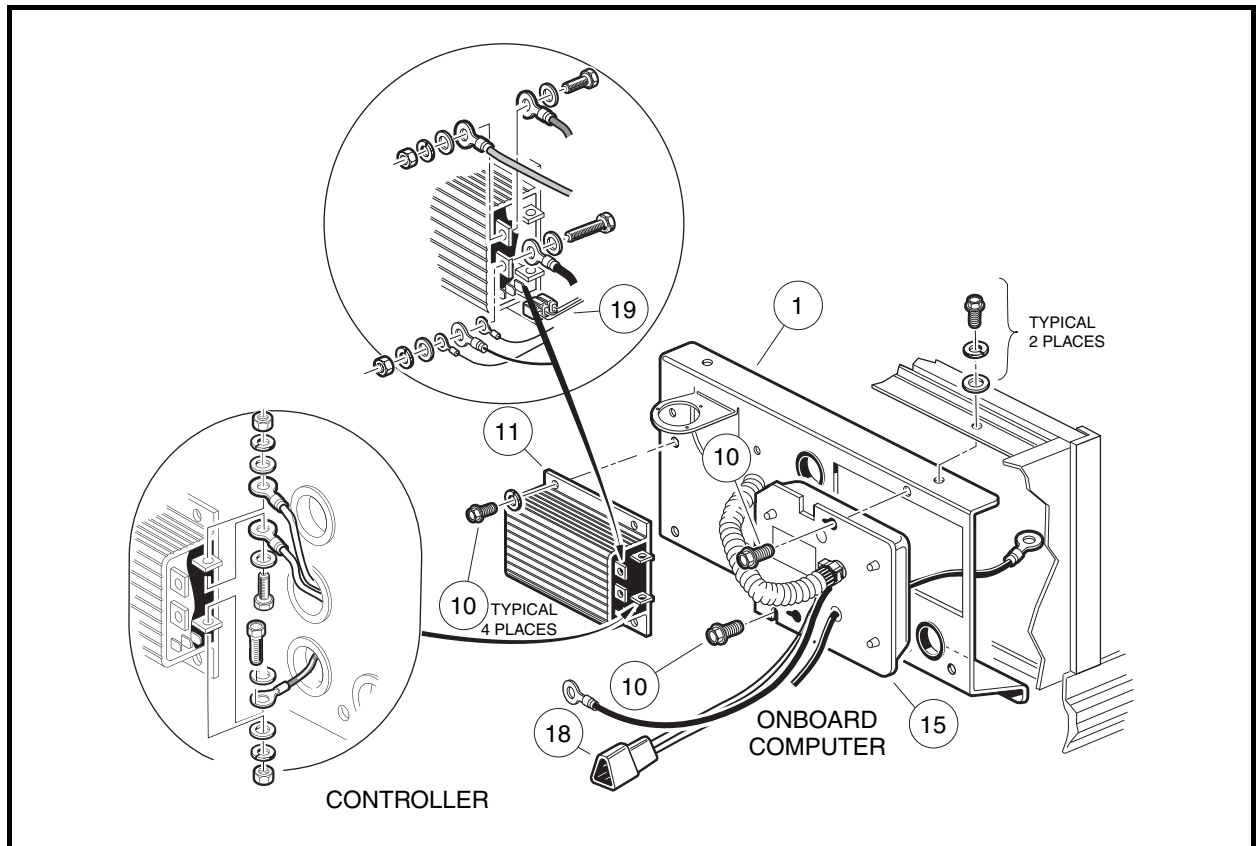


Figure 12-12 Controller and Onboard Computer – Turf 2, Carryall 2 and 6, Villager 6 and 8, and TransPorter Vehicles

Onboard Computer Installation

1. Install the OBC in reverse order of removal. Tighten 1/4 thread-rolling screws (10) to 50 in-lb (5.6 N·m) (**Figure 12-11, Page 12-12 or Figure 12-12, Page 12-12**). Tighten the nut securing the 10-gauge black wire to the receptacle fuse link to 23 in-lb (2.6 N·m).
2. Connect the battery cables, positive (+) cable first. Tighten battery terminals to 110 in-lb (12.4 N·m) and coat terminals with Battery Terminal Protector Spray (CCI P/N 1014305) to minimize corrosion.

SOLID STATE SPEED CONTROLLER

See General Warning, Section 10, Page 10-1.

Testing the Speed Controller

See Test Procedure 8, Section 11, Page 11-24.

Speed Controller Removal

1. Disconnect the battery cables as instructed. See **WARNING “To avoid unintentionally starting...” in General Warning, Section 10, Page 10-1**.
2. Remove all 6-gauge wires connected to the controller (11) (**Figure 12-11, Page 12-12 or Figure 12-12, Page 12-12**).
3. Unplug the three 18-gauge wires (19) plugged into the controller.
4. Remove the four 1/4 thread-rolling screws (10) holding the controller to the mounting plate (1).
5. Remove the controller from the vehicle.

Speed Controller Installation

1. Install in reverse order of disassembly. Tighten 1/4 thread-rolling screws (10) holding controller to mounting plate to 50 in-lb (5.6 N·m) (**Figure 12-11, Page 12-12 or Figure 12-12, Page 12-12**). Connect wires to terminals and tighten to 120 in-lb (13.6 N·m).
2. Connect the battery cables, positive (+) cable first. Tighten battery terminals to 110 in-lb (12.4 N·m) and coat terminals with Battery Terminal Protector Spray (CCI P/N 1014305) to minimize corrosion.

CHARGER RECEPTACLE

See General Warning, Section 10, Page 10-1.

NOTE: Carryall 6 and TransPorter vehicles are equipped with onboard chargers and therefore not equipped with charger receptacles.

The charger cord, plug, and receptacle are wear items and should be inspected daily. Visually inspect them for cracks, loose connections, and frayed wiring; they must be replaced when worn or damaged. If charger plug or receptacle show signs of corrosion or the plug is difficult to insert or remove, the receptacle contacts and plug terminals should be cleaned with a good electrical contact cleaner or lightly sprayed with WD-40® brand spray lubricant. The plug should then be inserted and removed several times to ensure ease of insertion, ease of removal, and good electrical contact. **See DC Cord in the appropriate battery charger maintenance and service manual for DC cord removal and installation. See following NOTE.**

NOTE: If the warning tag has been damaged or removed from the DC cord, have it replaced immediately.

Testing the Charger Receptacle

See Test Procedure 11, Section 11, Page 11-27.

See also the appropriate battery charger maintenance and service manual.

Charger Receptacle Inspection

Inspect the receptacle for cracks, loose connections, and frayed wiring.

Charger Receptacle Removal

NOTE: Disassembly of the charger receptacle, for the purpose of removal or installation, is not recommended.

1. Disconnect the battery cables as instructed. See **WARNING “To avoid unintentionally starting...”** in **General Warning, Section 10, Page 10-1.**
2. Remove the 10-gauge red wire (4) from the positive (+) post of battery no. 1 (**Figure 12-13, Page 12-14**).
3. Remove 10-gauge black OBC wire (5) from charger receptacle assembly.
4. Disconnect the gray wire (9) from the receptacle at the yellow fuse holder.
5. Remove the four screws (1) that secure the charger receptacle bezel (7) to the receptacle backing plate (8) and to the vehicle body.
6. Move the receptacle assembly toward the front of the vehicle and tilt receptacle upwards in order for the receptacle to pass through the hole in the vehicle body.

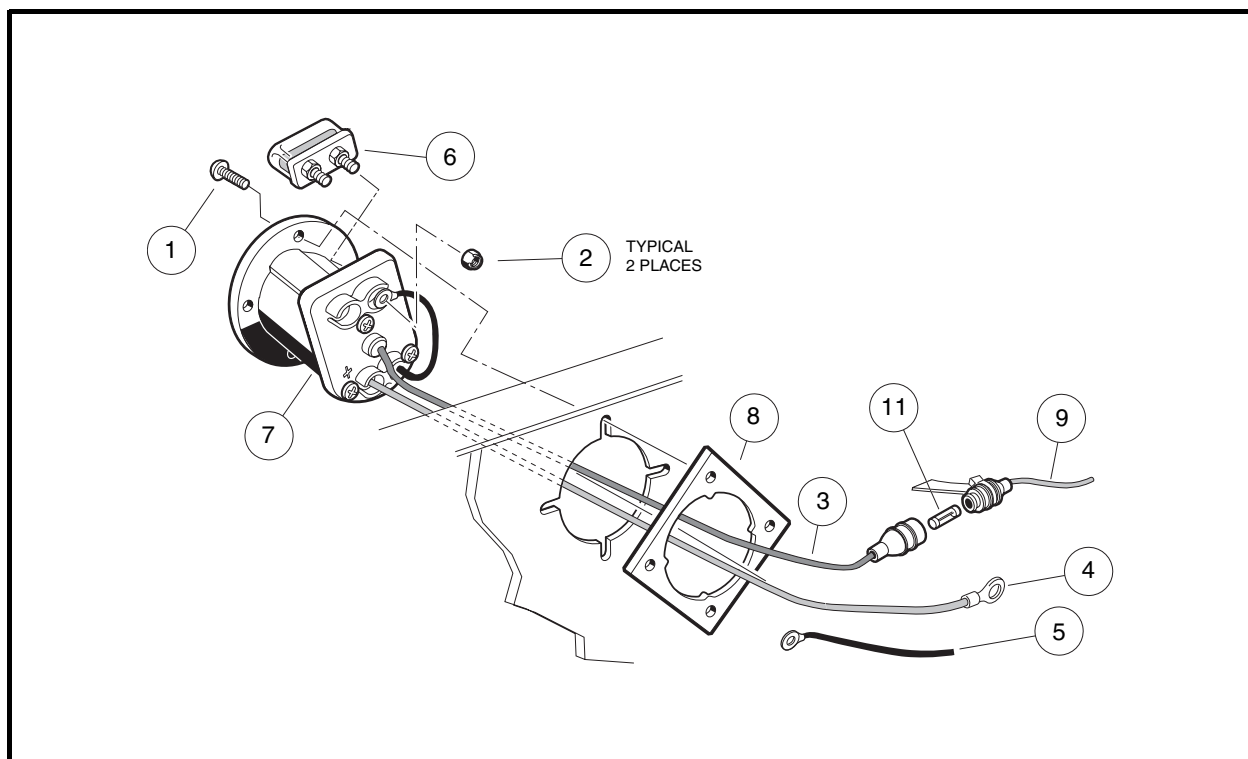


Figure 12-13 Charger Receptacle

Charger Receptacle Installation

1. Insert the 10-gauge red wire (4) and the 18-gauge gray wire (3) through the hole in the vehicle body and the receptacle backing plate (8) (**Figure 12-13, Page 12-14**).
2. Insert receptacle into vehicle body.
3. Install the four screws (1) that secure the receptacle assembly to the vehicle body and receptacle backing plate (8). Tighten screws to 16 in-lb (1.8 N·m).
4. Connect 18-gauge gray wire (9) to yellow fuse holder. Make sure fuse (11) is installed in fuse holder.
5. Connect the 10-gauge black wire (5) to the receptacle fuse link (6) on the charger receptacle assembly (**Figure 12-13, Page 12-14**). Tighten to 23 in-lb (2.6 N·m).
6. Connect the 10-gauge red wire (4) to the positive (+) post of battery no. 1. **See following WARNING.**

⚠ WARNING

- Do not bypass the sense lead fuse (11) on the receptacle wire (3) (**Figure 12-13, Page 12-14**).
7. Connect the battery cables, positive (+) cable first. Tighten battery terminals to 110 in-lb (12.4 N·m) and coat terminals with Battery Terminal Protector Spray (CCI P/N 1014305) to minimize corrosion.

RECEPTACLE FUSE LINK

The fuse link on the 48-volt Club Car electric vehicle should not blow under normal operating conditions; however, if the fuse link has blown, the vehicle will not charge and the fuse must be replaced. The fuse link (6) is mounted on top of the charger receptacle in the battery compartment (**Figure 12-13, Page 12-14**). **See DANGER on page 10-1, Section 10.**

Receptacle Fuse Link Removal

1. Remove the fuse link (6) from the charger receptacle (7) by removing the two nuts (2) and washers used to secure the 10-gauge black wire (5) from the computer and the 10-gauge black wire to the receptacle (**Figure 12-13, Page 12-14**).
2. Remove the fuse link (6) from the charger receptacle.

Receptacle Fuse Link Installation

1. Insert the two fuse link mounting posts into the mounting holes in the charger receptacle.
2. Place the two 10-gauge black wires in their original positions on the fuse link mounting posts. Tighten to 23 in-lb (2.6 N·m).
3. Install nuts (2) on fuse link mounting posts and tighten to 23 in-lb (2.6 N·m) (**Figure 12-13, Page 12-14**).

MOTOR CONTROLLER OUTPUT REGULATOR (MCOR)

See General Warning, Section 10, Page 10-1.

Testing the MCOR

See Test Procedure 7, Section 11, Page 11-21.

MCOR Removal

1. Disconnect the battery cables as instructed. **See WARNING “To avoid unintentionally starting...” in General Warning, Section 10, Page 10-1.**

MCOR Removal, Continued:

2. Place chocks at rear wheels and lift the front of the vehicle with a chain hoist or floor jack. Place jack stands under the round tube crossmember of the frame to support vehicle. **See WARNING “Lift only one end...” in General Warning, Section 10, Page 10-2.**
3. Disconnect the two-pin and three-pin connectors (1) from the MCOR (2) (**Figure 12-14, Page 12-16**).
4. Remove the hex-head screws (3) connecting the MCOR to the frame I-beam.
5. Remove the MCOR from vehicle.
6. Push the drive bar (4) into the hole in the I-beam to disengage it from the accelerator pivot rod (5).

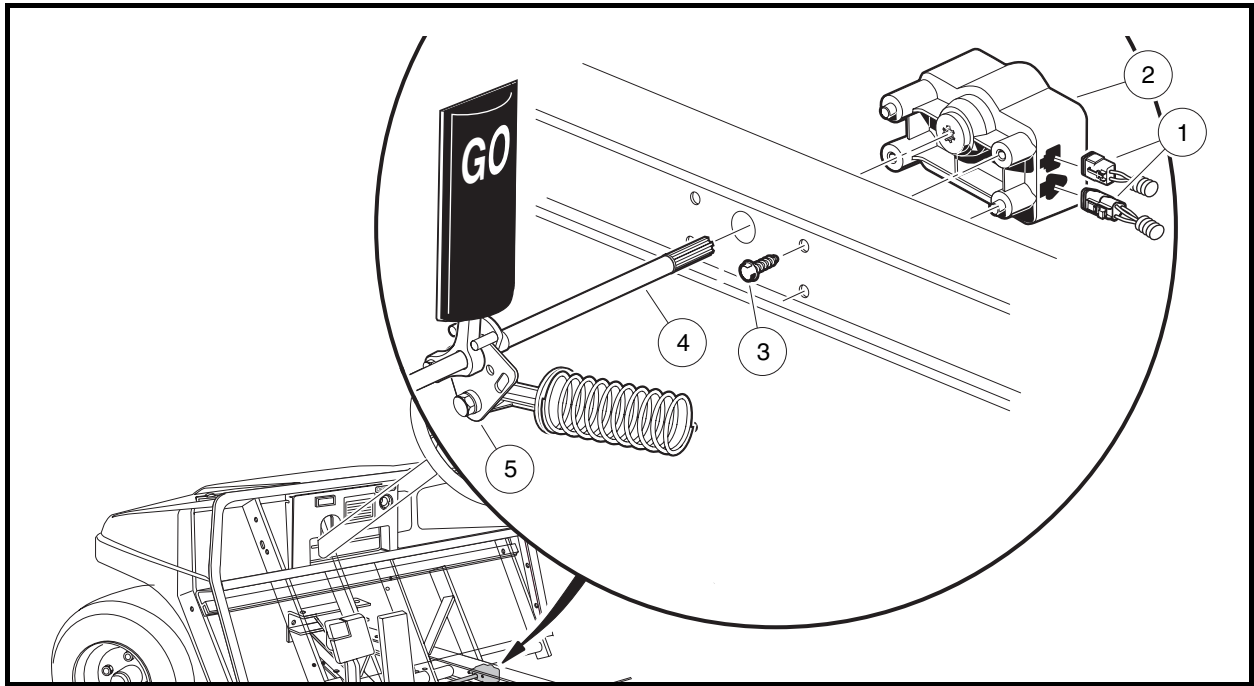


Figure 12-14 Motor Controller Output Regulator (MCOR) Mounting

MCOR Installation

1. Lift the wire conduit above the access hole in the passenger side I-beam, then insert the splined end of the drive bar (4) through the hole in the passenger-side I-beam as shown (**Figure 12-14, Page 12-16**).
2. Place the opposite end of the drive bar on the short extension of the pivot rod, with accelerator pedal positioned between the two pins.
3. Place the MCOR (2) onto the splined end of the drive bar (**Figure 12-14, Page 12-16**). **See following NOTE.**

NOTE: The MCOR is keyed to ensure correct positioning on the drive bar.

4. Insert the alignment pins on the MCOR into the holes in the I-beam as shown.
5. Secure the MCOR to the frame I-beam with two hex-head screws (3). Tighten screws to 23 in-lb (2.6 N·m).
6. Connect the two-pin and three-pin connectors (1) from the wire harness to the MCOR.
7. Connect the battery cables, positive (+) cable first. Tighten battery terminals to 110 in-lb (12.4 N·m) and coat terminals with Battery Terminal Protector Spray (CCI P/N 1014305) to minimize corrosion.

VOLTAGE LIMITER

See General Warning, Section 10, Page 10-1.

Testing the Voltage Limiter

See Test Procedure 20, Section 11, Page 11-37.

Voltage Limiter Removal

1. Disconnect the battery cables as instructed. **See WARNING “To avoid unintentionally starting...” in General Warning, Section 10, Page 10-1.**
2. Remove the nut securing the 10-gauge black wire from the voltage limiter to the B– terminal on the speed controller and remove the wire.
3. Remove the two 1/4-inch quick disconnect terminals from the voltage limiter to the ground terminal block.
4. Note the routing of the voltage limiter wiring and the location of the wire ties securing the wiring.
5. Remove the two nuts (14) securing the voltage limiter (12) to the I-beam (**Figure 12-15, Page 12-17**).
6. Remove the voltage limiter (12) and the thermal pad (13) from the vehicle.

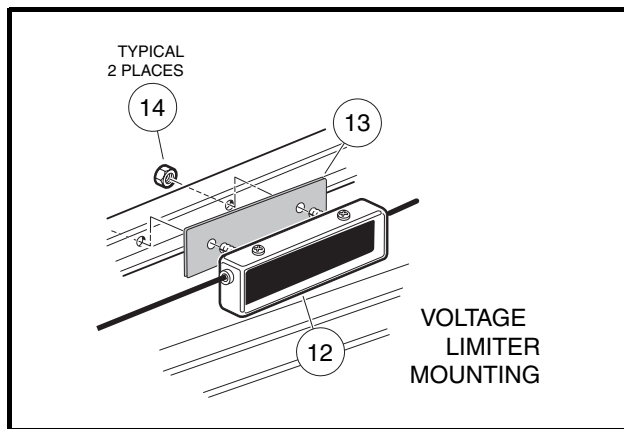


Figure 12-15 Voltage Limiter

Voltage Limiter Installation

1. Place the thermal pad (13) on the two voltage limiter mounting studs as shown (**Figure 12-15, Page 12-17**).
2. Install the voltage limiter on the inboard side of the I-beam. Insert the mounting studs through the mounting holes. Install a locknut (3) on each stud and tighten the voltage limiter to 65 in-lb (7.3 N·m).
3. Route the wiring from the voltage limiter in the same manner as the voltage limiter that was removed.
4. Secure the voltage limiter wiring with wire ties in the locations noted in step 4 of Voltage Limiter Removal.
5. Connect the two 1/4-inch quick disconnect terminals to the ground terminal block.
6. Connect the voltage limiter 10-gauge black wire to the B– terminal on the speed controller. Tighten the nut on the B– terminal to 10 ft-lb (13.6 N·m).
7. Connect the battery cables, positive (+) cable first. Tighten battery terminals to 110 in-lb (12.4 N·m) and coat terminals with Battery Terminal Protector Spray (CCI P/N 1014305) to minimize corrosion.

BRAKE PEDAL LIMIT SWITCH

See General Warning, Section 10, Page 10-1.

Testing the Brake Pedal Limit Switch

See Test Procedure 24, Section 11, Page 11-40.

Brake Pedal Limit Switch Removal

1. Disconnect the battery cables as instructed. See **WARNING “To avoid unintentionally starting...”** in General Warning, Section 10, Page 10-1.
2. Remove the two wires from the brake pedal limit switch (2) (**Figure 12-16, Page 12-18**).
3. Remove the nut (7), washer (8), and screw (6) from the limit switch bracket (1).
4. Remove the nut (5) from the limit switch bracket.
5. Remove the limit switch and bracket from the vehicle.

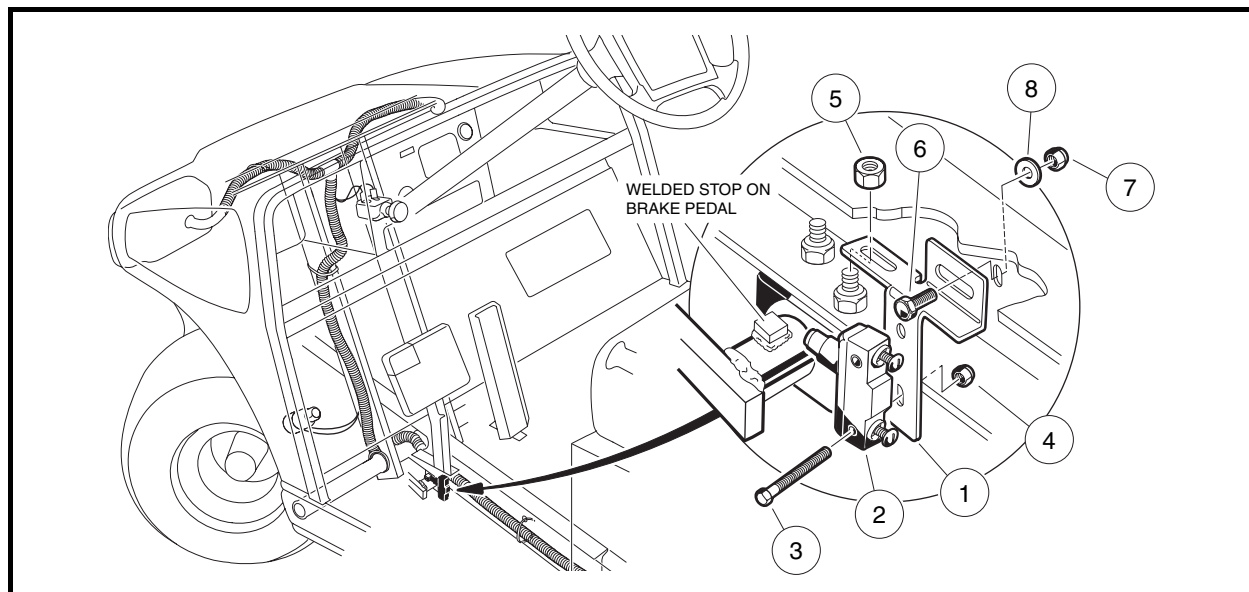


Figure 12-16 Brake Pedal Limit Switch

Brake Pedal Limit Switch Installation

1. Install in the reverse order of removal, leaving the screw (6) and nut (5) loose (**Figure 12-16, Page 12-18**).
2. Adjust the limit switch bracket by sliding the bracket to the front or rear of the vehicle as required. When properly adjusted:
 - The limit switch plunger should be activated when the brake pedal is not pressed.
 - The limit switch plunger should not be activated only when the brake pedal is pressed.
3. With the limit switch bracket adjusted as described in the previous step, tighten the nut (5) and locknut (7) to 40 in-lb (4.5 N·m).
4. Connect wires to limit switch terminals and tighten the electrical connections to 10 in-lb (1.1 N·m).
5. Connect the battery cables, positive (+) cable first. Tighten battery terminals to 110 in-lb (12.4 N·m) and coat terminals with Battery Terminal Protector Spray (CCI P/N 1014305) to minimize corrosion.

PARK BRAKE PEDAL LIMIT SWITCH

See General Warning, Section 10, Page 10-1.

Testing the Park Brake Pedal Limit Switch

See Test Procedure 25, Section 11, Page 11-41.

Park Brake Pedal Limit Switch Removal

1. Disconnect the battery cables as instructed. See **WARNING “To avoid unintentionally starting...”** in **General Warning, Section 10, Page 10-1.**
2. Remove the pad from the brake pedal by removing the four no. 10 screws and sliding the pad to the right.
3. Remove the screws (2) securing the wire terminals to the park brake switch (3) (**Figure 12-17, Page 12-19**).
4. Remove the hex nuts (5) and machine screws (4) securing the limit switch to the brake pedal and remove the switch.

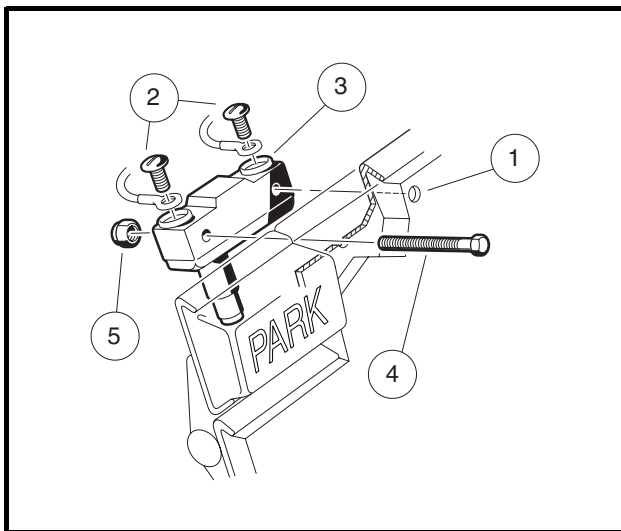


Figure 12-17 Park Brake Limit Switch

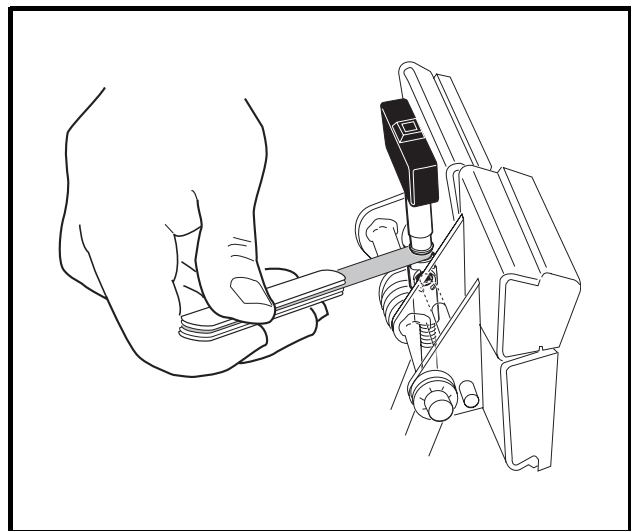


Figure 12-18 Park Brake Limit Switch Gap Adjustment

Park Brake Pedal Limit Switch Installation

1. Secure the switch to the park brake pedal with locknuts (5) and hex-head machine screws (4) (**Figure 12-17, Page 12-19**). Set the gap between the switch and the top of the park brake rod to no more than 0.030 of an inch (0.762 mm) (**Figure 12-18, Page 12-19**). Tighten the mounting hardware to 10 in-lb. (1.1 N·m).
2. Connect the 16-gauge orange/white wire to the NC (normally closed) terminal and the 16-gauge brown wire to the COM (common) terminal. Tighten screws to 10 in-lb (1.1 N·m).
3. Install pad on brake pedal, and tighten the screws until the pad is secure.
4. Connect the battery cables, positive (+) cable first. Tighten battery terminals to 110 in-lb (12.4 N·m) and coat terminals with Battery Terminal Protector Spray (CCI P/N 1014305) to minimize corrosion.

BRAKE LIGHT RELAY

See General Warning, Section 10, Page 10-1.

Testing the Brake Light Relay

See Test Procedure 19, Section 11, Page 11-33.

Brake Light Relay Removal

1. Disconnect the battery cables as instructed. See **WARNING “To avoid unintentionally starting...”** in **General Warning, Section 10, Page 10-1.**
2. Remove the front body. See **Front Body Removal in Section 4 of the appropriate maintenance and service manual.**
3. Remove the two voltage suppressor wires (11) from the coil terminals of the brake light relay (12) (**Figure 12-19, Page 12-20**).
4. Remove the two wires from the contact terminals of the brake light relay.
5. Remove the two nuts (15), two screws (13), and two washers (14) from the brake light relay (12).
6. Remove the brake light relay from the vehicle.

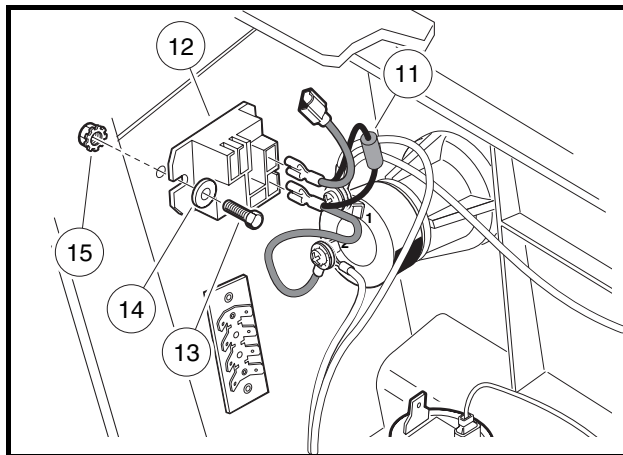


Figure 12-19 Brake Light Relay

Brake Light Relay Installation

1. Secure the brake light relay (12) to the vehicle frame as shown with two screws (13), two washers (14), and two nuts (15) (**Figure 12-19, Page 12-20**). Tighten nuts to 30 in-lb (3.4 N·m)
2. Connect the two wires from the voltage suppressor (11) to the coil terminals on the brake light relay (12) as shown.
3. Connect the two brake light wires to the COM (common) and NO (normally open) terminals of the brake light relay.
4. Install the front body. See **Front Body Installation in Section 4 of the appropriate maintenance and service manual.**
5. Install the center dash panel in the reverse order of removal. Be sure the key switch terminals cannot touch the frame and that the panel is properly seated and snapped in place.
6. Connect the battery cables, positive (+) cable first. Tighten battery terminals to 110 in-lb (12.4 N·m) and coat terminals with Battery Terminal Protector Spray (CCI P/N 1014305) to minimize corrosion.

LIGHT SWITCH

See General Warning, Section 10, Page 10-1.

Testing the Light Switch

See Test Procedure 18, Section 11, Page 11-32.

Light Switch Removal

1. Disconnect the battery cables as instructed. See **WARNING “To avoid unintentionally starting...”** in **General Warning, Section 10, Page 10-1.**
2. Loosen the set screw locking the light switch knob (1) to the shaft (**Figure 12-20, Page 12-21**).
3. Remove center dash panel. See **step 2 of Key Switch Removal on page 12-1.**
4. Disconnect the wires from the light switch.
5. Remove the outer nut (2) from the switch (**Figure 12-20, Page 12-21**).
6. Remove the light switch (3) from the center dash.

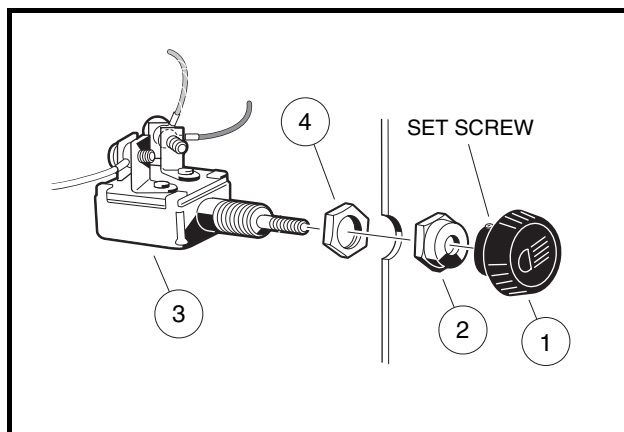


Figure 12-20 Light Switch

Light Switch Installation

1. Connect the wires to the light switch. See the appropriate wiring diagram in Section 11, starting on page 11-2.
2. Thread the check nut (4) onto the switch until an equal number of threads show on both sides. Insert the switch through the center dash and install the nut on the outside of the dash. Tighten the nut to 14 in-lb (1.6 N·m) (**Figure 12-20, Page 12-21**).
3. Push the light switch shaft in. Screw the knob onto the end of the shaft until the knob touches the outer nut. Then turn the knob in the opposite direction until the headlight beams on the knob are horizontal to the ground. Tighten the set screw to lock the knob to the shaft.
4. Install the center dash in the reverse order of removal. Be sure the key switch terminals cannot touch the frame and that the panel is properly seated and snapped in place.
5. Connect the battery cables, positive (+) cable first. Tighten battery terminals to 110 in-lb (12.4 N·m) and coat terminals with Battery Terminal Protector Spray (CCI P/N 1014305) to minimize corrosion.

BATTERY WARNING LIGHT

See General Warning, Section 10, Page 10-1.

Testing the Battery Warning Light

See Test Procedure 10, Section 11, Page 11-27.

Battery Warning Light Removal

1. Disconnect the battery cables as instructed. **See WARNING “To avoid unintentionally starting...” in General Warning, Section 10, Page 10-1.**
2. Remove center dash panel. **See step 2 of Key Switch Removal on page 12-1.**
3. Disconnect the brown wire at the quick disconnect terminal and remove the orange/white wire from the key switch.
4. Press the two retaining tabs (11) and remove the light from the center dash (**Figure 12-21, Page 12-22**).

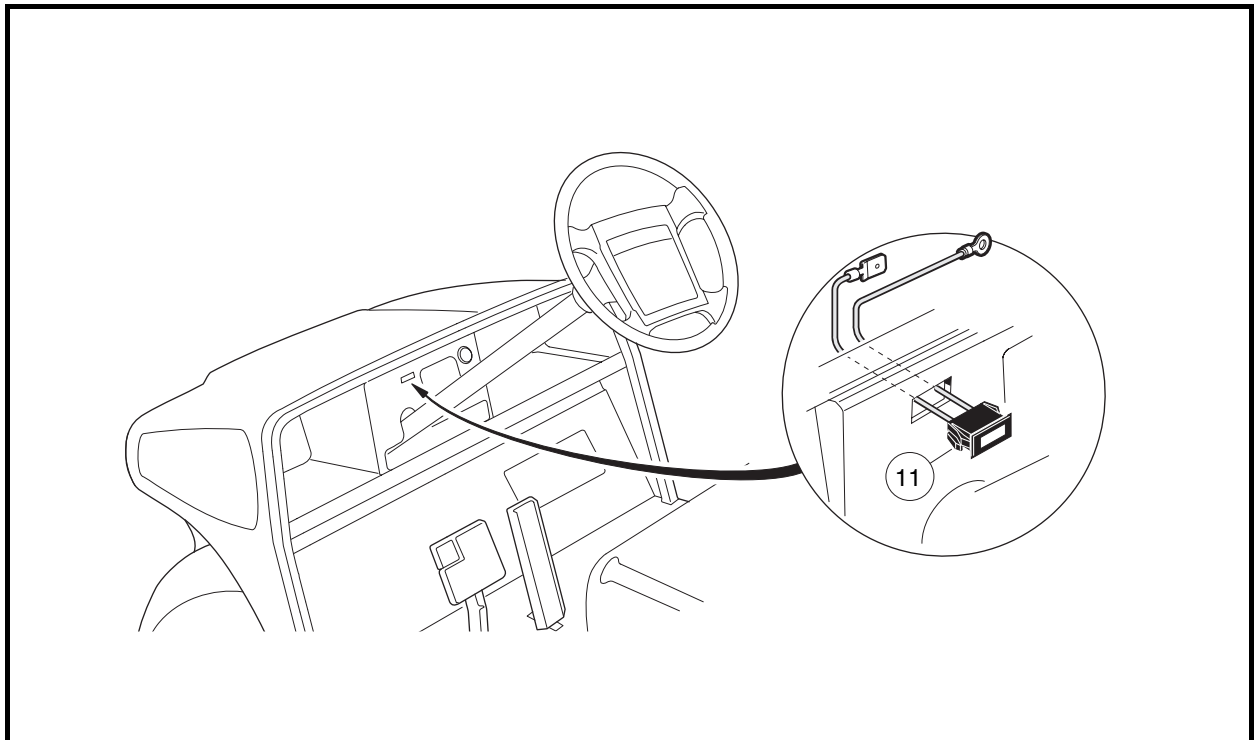


Figure 12-21 Battery Warning Light

Battery Warning Light Installation

1. Install in reverse order of removal.
2. Connect the battery cables, positive (+) cable first. Tighten battery terminals to 110 in-lb (12.4 N·m) and coat terminals with Battery Terminal Protector Spray (CCI P/N 1014305) to minimize corrosion.

HORN

See General Warning, Section 10, Page 10-1.

Testing the Horn

See Test Procedure 27, Section 11, Page 11-43.

Horn Removal

1. Disconnect the battery cables as instructed. See **WARNING “To avoid unintentionally starting...”** in **General Warning, Section 10, Page 10-1.**
2. Remove center dash panel. See **step 2 of Key Switch Removal on page 12-1.**
3. Disconnect the orange wire (1) from the horn (2) (**Figure 12-22, Page 12-23**).
4. Remove the hex nut (3), lockwasher (4), and the black wire (5) from the mounting stud on the front of the horn.
5. Remove the horn from the vehicle.

Horn Installation

1. Install the orange wire onto the horn. Slip the black wire ring terminal onto the mounting stud.
2. Install the horn stud through the mounting bracket (6). Install the lockwasher and nut onto the mounting stud and tighten the horn to 8 ft-lb (10.8 N·m) (**Figure 12-22, Page 12-23**). See following **NOTE**.

NOTE: Shoulder portion of hex nut (3) fits into horn bracket (6).

3. Connect the battery cables, positive (+) cable first. Tighten battery terminals to 110 in-lb (12.4 N·m) and coat terminals with Battery Terminal Protector Spray (CCI P/N 1014305) to minimize corrosion.

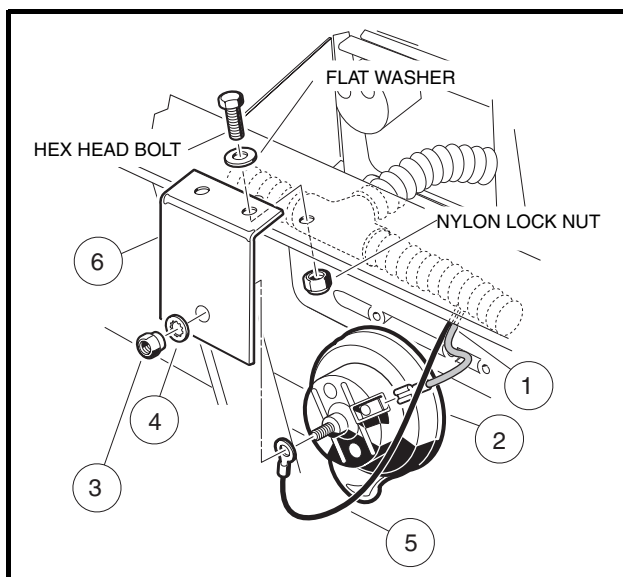


Figure 12-22 Horn

HORN SWITCH

See General Warning, Section 10, Page 10-1.

Testing the Horn Switch

See Test Procedure 26, Section 11, Page 11-42.

Horn Switch Removal

1. Disconnect the battery cables as instructed. See **WARNING “To avoid unintentionally starting...”** in **General Warning, Section 10, Page 10-1.**
2. Unscrew the rubber cap (1) from the horn switch (2) (**Figure 12-23, Page 12-24**).
3. Disconnect the horn wires at the two-pin connector on the horn switch beneath the floorboard.
4. Remove the horn switch from beneath the floorboard.

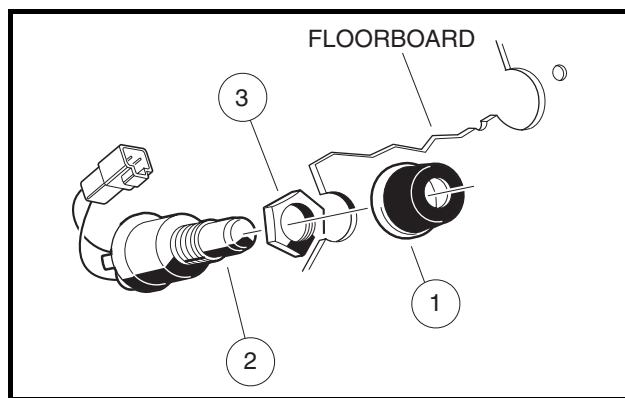


Figure 12-23 Horn Switch

Horn Switch Installation

1. Install the jam nut (3) until it makes contact with the body of the horn switch (**Figure 12-23, Page 12-24**).
2. Insert the horn switch into the hole from beneath the floorboard. Screw the rubber cap onto the switch from above the floorboard until the push-button tip of the switch extends through the hole in the rubber cap. Tighten the jam nut to 22 in-lb (2.5 N·m).
3. Connect the wire harness at the connector on the horn switch.
4. Connect the battery cables, positive (+) cable first. Tighten battery terminals to 110 in-lb (12.4 N·m) and coat terminals with Battery Terminal Protector Spray (CCI P/N 1014305) to minimize corrosion.

HOUR METER

See General Warning, Section 10, Page 10-1.

Testing the Hour Meter

See Test Procedure 29, Section 11, Page 11-44.

Hour Meter Removal

1. Turn the key switch to the OFF position, place the Forward/Reverse switch in the NEUTRAL position, and engage the park brake.
2. Remove the seat to allow access to the component mounting plate.
3. Locate the hour meter (1) on the component mounting plate and remove the two wires (16 and 17) connected to the terminals on the bottom of the meter (**Figure 12-24, Page 12-25**).
4. Remove the three screws (15) securing the hour meter to the component mounting plate.
5. Remove the hour meter from the vehicle.

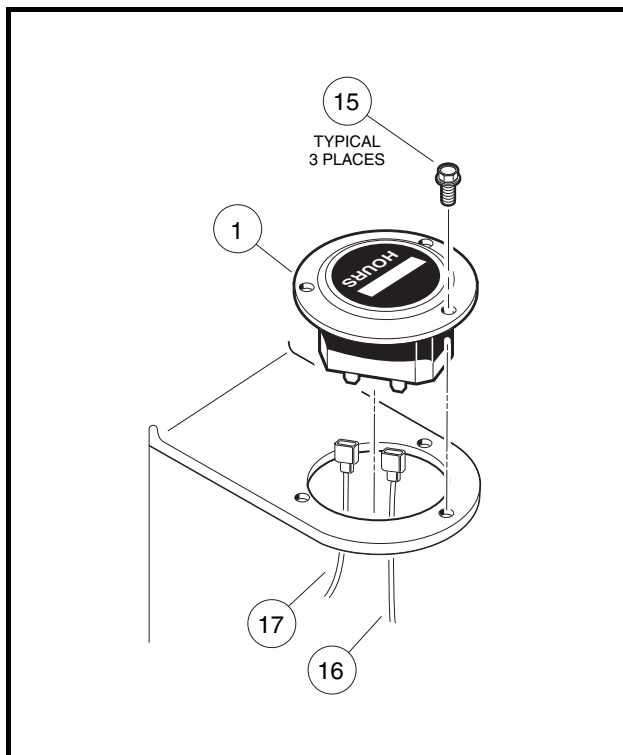


Figure 12-24 Hour Meter

Hour Meter Installation

1. Insert the hour meter (1) into the mounting location on the component mounting plate (**Figure 12-24, Page 12-25**).
2. Secure the meter to the component mounting plate with three screws (15).
3. Connect the two wires (16 and 17) to the terminals on the bottom of the meter. **See following NOTE.**

NOTE: The red wire must be connected to the positive (+) terminal for the hour meter to function.

4. Install the seat.

SECTION 13 – BATTERIES

⚠ DANGER

- See General Warning, Section 10, Page 10-1.

⚠ WARNING

- See General Warning, Section 10, Page 10-1.

GENERAL INFORMATION

The batteries supplied with an electric Club Car vehicle are different from those supplied with an automobile. The outward appearances of these two types of batteries are similar, but the operating characteristics are very different. The Club Car electric vehicle battery is a deep-cycle battery, and the automotive battery is a “starting, lighting and ignition” (SLI) battery. They should never be substituted for one another.

BATTERY REPLACEMENT

See General Warning, Section 10, Page 10-1.

⚠ WARNING

- To prevent electrolyte leakage from the battery vents, batteries must be kept in an upright position. Tipping a battery beyond a 45° angle in any direction can allow a small amount of electrolyte to leak out the vent hole. Do not exceed this 45° angle when lifting, carrying, or installing batteries. Battery acid can cause severe personal injury to skin or eyes, and can damage clothing.
1. Before removing batteries, note the orientation of the batteries and the connecting wires. Disconnect the battery cables as instructed. **See WARNING “To avoid unintentionally starting...” in General Warning, Section 10, Page 10-1.** Remove remaining wires and batteries. **See Wiring Diagrams, Section 11, Page 11-2.**
 2. Visually inspect the new batteries for any damage that may have occurred in transit.
 3. If the battery cables are to be reused, inspect them for broken or frayed wires, damaged terminals, or worn insulation. Remove any corrosion on the connectors. A solution of baking soda and water (1 cup (237 mL) baking soda per 1 gallon (3.8 L) of water) does an excellent job of neutralizing and removing the corrosion. Be careful not to allow the baking soda solution to enter the battery.
 4. Check and clean the battery rack and hold-downs. The nuts and bolts on the hold-downs may corrode. It is therefore advised they be cleaned periodically and replaced as necessary.
 5. Install batteries in the proper orientation (**Figure 13-1, Page 13-2**). Install battery hold-downs. The hold-downs should be tight enough so batteries do not move while vehicle is in motion, but not so tight as to crack or buckle battery case. Tighten to 40 in-lb (4.5 N·m), alternating between hold-down bolts.

Battery Replacement, Continued:

6. Install wires in proper sequence (**Figure 13-1, Page 13-2**). Install black wire to negative (–) post of battery no. 6 last. Make sure all connections are tight. Tighten to 110 in-lb (12.4 N-m). Coat all terminals with Battery Terminal Protector Spray (CCI P/N 1014305) to minimize future corrosion.
7. Give the batteries a full charge prior to operation. This ensures all the batteries are fully charged and the cells are equalized prior to use.

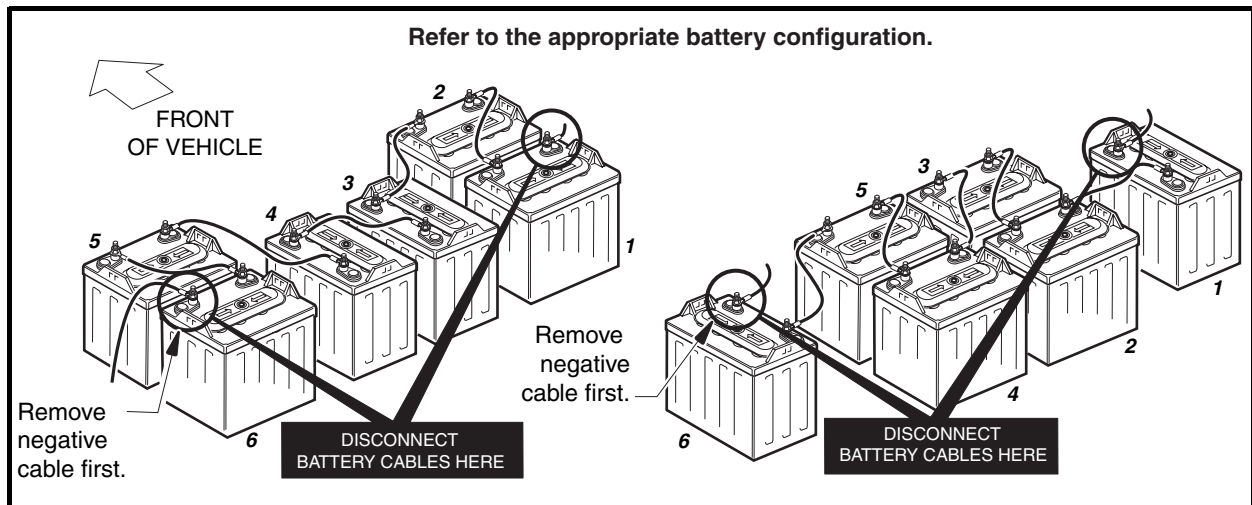


Figure 13-1 Battery Configuration

BATTERY CARE

See General Warning, Section 10, Page 10-1.

PREVENTIVE MAINTENANCE

To keep batteries in sound operating condition, follow these steps on a regular basis.

1. Any corrosion build-up on or around batteries should be removed immediately. Terminal connections should be clean and tight. Any frayed or worn wires should be replaced. After all cables have been connected, coat all terminals with Battery Terminal Protector Spray (CCI P/N 1014305) to help prevent future corrosion.
2. Batteries should be clean and free of corrosion. Wash tops and terminals of batteries with a solution of baking soda and water (1 cup (237 mL) baking soda per 1 gallon (3.8 L) of water). Rinse solution off batteries. Do not allow this solution to enter the batteries. Be sure terminals are tight. Let the terminals dry and then coat them with Battery Terminal Protector Spray (CCI P/N 1014305). **See Self-Discharge on page 13-3.**
3. Maintain proper electrolyte level. **See Electrolyte Level below.**
4. Batteries should be properly charged every day they are used. Check the batteries periodically to see that they are in a full state of charge. **See Battery Charging on page 13-4.**
5. Keep hold-downs tight. **See Vibration Damage on page 13-4.**

SELF-DISCHARGE

Contaminants on dirty batteries can provide a path for a small current draw that can slowly discharge batteries, thus wasting valuable energy. To prevent self-discharge, batteries should always be kept clean.

Hot weather also has an effect on a battery's self-discharge rate. The higher the temperature, the quicker a set of batteries will discharge. In hotter climates, batteries should be checked more often. When storing batteries, keep in a cool place. **See Battery Storage on page 13-12.**

ELECTROLYTE LEVEL

CAUTION

- **Do not allow battery acid from battery caps or hydrometer to drip onto the front or rear body of the vehicle. Battery acid will cause permanent damage. Wash immediately.**

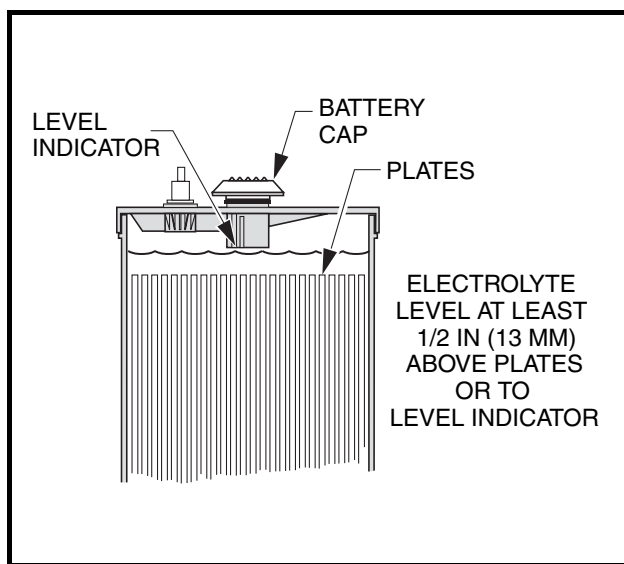


Figure 13-2 Battery Electrolyte Level

Add water only after charging unless the electrolyte is below the level of the plates. If the electrolyte level is below the level of the plates, add just enough water to cover the plates and then charge the batteries. After charging, fill with water to the level indicator. Filling a battery to the level indicator before charging will result in overfilling because the electrolyte level will rise during charging and some of the electrolyte may bubble out of the cap. This reduces the battery's capacity and corrodes the metal parts around it.

The electrolyte level should be checked weekly to be sure electrolyte is at its proper level (**Figure 13-2, Page 13-3**). Never allow the electrolyte level to fall below the tops of the plates because this will cause the exposed part of the plate to become permanently inactive. For best results, use a battery watering gun to add water to batteries. Check the electrolyte level more frequently in hot weather or when batteries are old.

MINERAL CONTENT

For the longest battery life, use distilled water in batteries. However, if tap water is to be used, be sure the mineral contents are below these levels:

IMPURITY	ALLOWABLE CONTENT (PARTS PER MILLION)
Suspended matter	Trace
Total solids	100.0
Calcium and Magnesium Oxides	40.0
Iron	5.0
Ammonia	8.0
Organic matter	50.0
Nitrates	10.0
Nitrites	5.0
Chloride	5.0

VIBRATION DAMAGE

The battery hold-downs should always be tight enough to keep the battery from bouncing. Battery life may be severely shortened if the battery hold-downs are too loose. Battery hold-downs should be tightened to 40 in-lb (4.5 N-m). Excessive vibration causes the plates to shed prematurely and shortens the life of the battery. It may also cause acid to leak out of the vent caps and corrosion to build up on surrounding metal parts. The acid which is lost reduces the capacity of the battery and cannot be replaced. Battery hold-downs should NOT be so tight as to crack or buckle the battery case. This may cause leaks, which would dry out a cell or cause internal short circuits. **See Battery Replacement on page 13-1.**

BATTERY CHARGING

See General Warning, Section 10, Page 10-1.

The charger supplied with the Club Car electric vehicle resolves the most common problems associated with battery charging. Undercharging and overcharging are prevented provided the charger is allowed to shut off by itself. Also, all cells are automatically given an equalization charge at low current, which prolongs battery life. Batteries should never be left in a discharged state, as this too affects the internal components and can reduce the capacity of the battery. The batteries should be charged every day they are used. However, the batteries should not be charged if they have not been used.

CHARGER SHUTS OFF AFTER 16 HOURS

This may be due to 1) new batteries, 2) hard use, or 3) cold temperatures. A catch-up charge may be necessary when these conditions are present. On those days when all or some of the vehicles do not get used, check the batteries for state of charge. Any battery with a specific gravity lower than 1.250 will need a catch-up charge. If the problem continues after a catch-up charge has been performed, check the battery charger. **See the appropriate battery charger maintenance and service manual.**

DEEP-DISCHARGE

Never discharge batteries to the point the vehicle will no longer operate. This will considerably shorten the cycle life of the batteries, and may permanently damage the batteries. It is possible the batteries will not accept a charge if they are completely discharged. The deeper the discharge, the harder it is on the batteries. For this reason, it is recommended that Club Car electric vehicle batteries be charged after each use (provided the charge cycle will not be interrupted and the charger will be allowed to shut off automatically). Placing the batteries on charge after each use reduces the depth of discharge and prolongs battery life.

EARLY EXCESSIVE DISCHARGING

When vehicle batteries are new, they do not reach their full capacity until they have been used and recharged 20 to 50 times. If they are excessively discharged early in their life, their effective service life will be shortened. It is advisable to limit the use of any vehicle with new batteries for at least the first four weeks and then gradually increase their range.

INCOMING AC SERVICE

Make sure the incoming AC line service is sufficient. If circuit breakers are tripping, fuses blow during the night or the charger does not give the required starting rate when sound batteries are put on charge, an AC line problem exists. The electrical service to the vehicle storage facility should be sufficient to deliver adequate voltage and current to each charger with all the chargers turned on. If not, consult your local power company or electrical contractor. **See the appropriate battery charger maintenance and service manual.**

FLEET ROTATION

Rotate vehicle usage. It is very hard on batteries if the last vehicles in at night are the first ones out in the morning. Spread the workload evenly, giving all vehicles the same amount of use. This will keep your fleet in balance and will not overwork certain sets of batteries. **See following NOTE.**

NOTE: When vehicles are being rotated, the Club Car CDM (Communication Display Module) can be a very helpful service tool. Monitoring the value of function 3 with the CDM simplifies vehicle usage scheduling. **See Communication Display Module (CDM), Section 11, Page 11-45.**

NUMBERING VEHICLES AND CHARGERS

Return the vehicles to the same charger each night if possible. If the vehicles are put in a storage facility at random and a vehicle dies while in use and testing shows the batteries are sound, then the problem is most likely with the charger. However, finding the problem charger may prove to be quite time consuming. Numbering the vehicles and the chargers and returning each vehicle to its designated charger each night can significantly reduce the amount of time spent troubleshooting a problem.

BATTERY TROUBLESHOOTING CHART

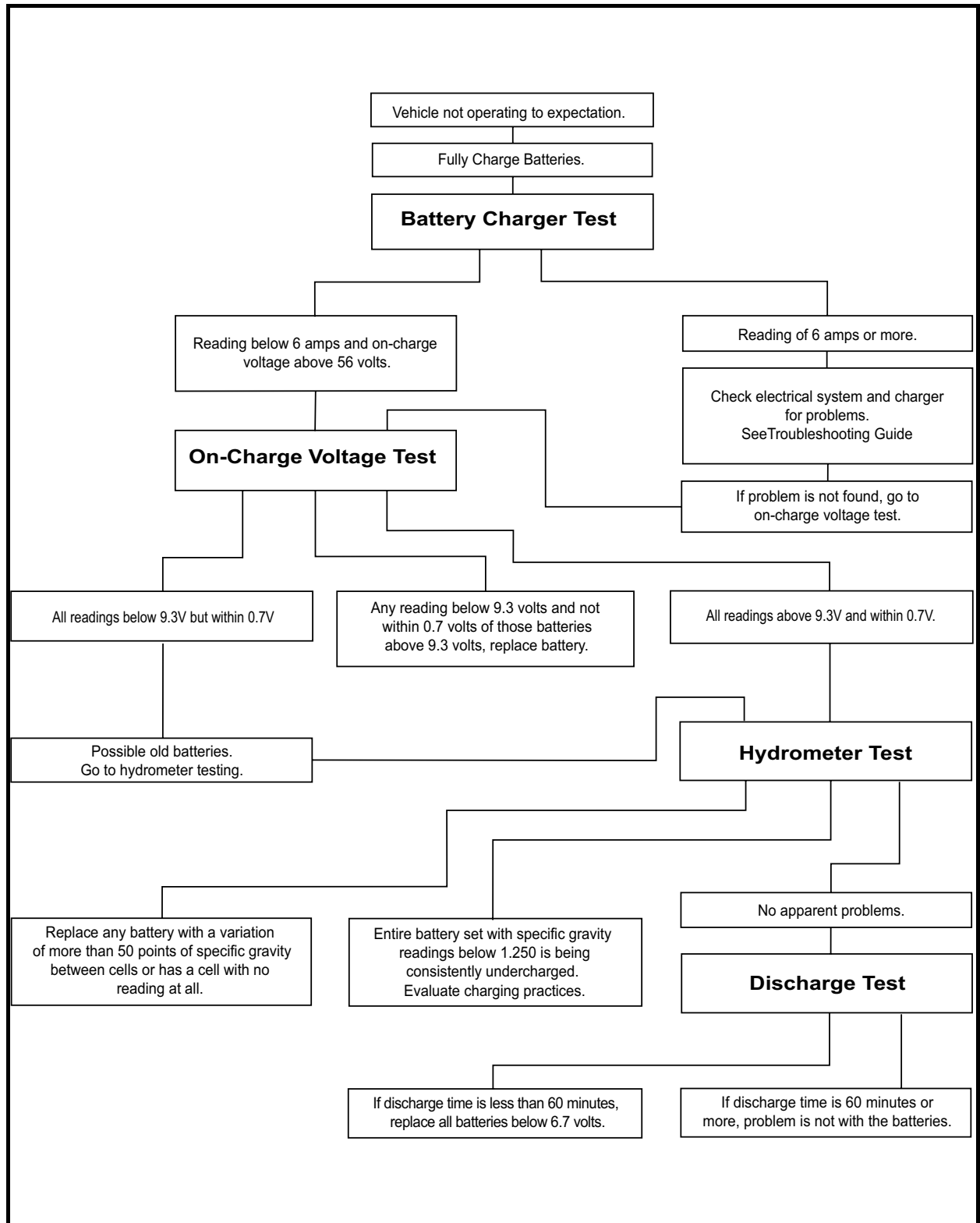


Figure 13-3 Battery Troubleshooting Chart

BATTERY TESTING

See General Warning, Section 10, Page 10-1.

Four tests have been developed to help diagnose problems with batteries that have not performed as expected. Because each test becomes progressively more detailed and time-consuming, begin with the first test and follow through with the other tests until the problem has been identified as outlined in the Battery Troubleshooting Chart (**Figure 13-3, Page 13-6**).

BATTERY CHARGER TEST

The easiest way to monitor the condition of a vehicle's batteries is simply to observe the reading on the battery charger ammeter at the end of the charge cycle. After a full charge, disconnect the charger DC plug, wait 20 to 30 seconds and reconnect the charger DC plug. The ammeter needle will jump to 15 amps or more and then taper to below 6 amps within 10 to 20 minutes, indicating sound, fully charged batteries.

Continued poor performance may indicate a problem in the vehicle electrical system, brakes, or battery charger. If the problem is not found in the vehicle or charging system, proceed to the on-charge voltage test. Batteries that remain at 8 amps or higher should be tested further using the on-charge voltage test.

ON-CHARGE VOLTAGE TEST

When the batteries are fully charged, disconnect the charger DC plug. Wait 20 to 30 seconds and reconnect the DC plug to restart the charger. After 5 minutes, use a multimeter to check and record the voltage of the battery set as well as the individual batteries. Set the multimeter to 200 volts DC. Place the red (+) probe on the positive (+) post of battery no. 1 and the black (-) probe on the negative (-) post of battery no. 6 (**Figure 13-1, Page 13-2**). Record reading. Then set multimeter to 20 volts DC and place the red (+) probe on the positive (+) post and the black (-) probe on the negative (-) post of each battery. Record the readings.

The on-charge voltage for the set should be between 56.0 volts and 63.0 volts depending on the age and state of charge of the batteries being tested. If individual batteries read above 9.3 volts and are within 0.7 volts of each other, go to the hydrometer test. If any battery reads below 9.3 volts and not within 0.7 volts of those batteries above 9.3 volts, replace battery. If readings are below 9.3 volts but within 0.7 volts of each other, the batteries are old. Old batteries may have enough capacity left to last several more months. Go to hydrometer test. **See Battery Troubleshooting Chart on page 13-6 and the examples on the following pages.**

HYDROMETER TEST

A hydrometer measures the specific gravity of the battery's electrolyte. The higher the specific gravity, the higher the state of charge of the batteries. A fully charged battery should read between 1.250 and 1.280 at 80 °F (26.7 °C). Never add acid to batteries to obtain a higher specific gravity.

Performing the Hydrometer Test

1. Be sure batteries have sufficient electrolyte to cover plates by approximately 1/2 inch (13 mm) and are fully charged prior to beginning test. If water must be added, recharge the batteries before performing the hydrometer test.
2. Remove the vent cap. Using a battery thermometer (CCI P/N 1011767), record electrolyte temperature of the no. 2 cell.
3. Squeeze the rubber bulb of the hydrometer and insert into the cell. Slowly release the bulb, drawing electrolyte up into the glass tube of the hydrometer.
4. When the float rises off the bottom, adjust the electrolyte level so that the float rides free of the bottom but does not strike the top of the glass tube. Remove the hydrometer from the cell and release the pressure from the bulb.

Performing the Hydrometer Test, Continued:

5. Hold the hydrometer vertically, ensuring that the float is not touching the sides of the barrel. Hold the hydrometer at eye level and read the scale at the level of electrolyte (**Figure 13-4, Page 13-8**).
6. Record the reading and return the electrolyte to the cell from which it was taken. Replace vent cap.
7. Repeat steps 2 through 6 on all cells.

Hydrometer Calibration

Most hydrometers are calibrated to read correctly at 80 °F (26.7 °C). The readings obtained as described above must be corrected for temperature. For each 10 °F (5.6 °C) above 80 °F (26.7 °C), add 0.004 to the reading. For each 10 °F (5.6 °C) below 80 °F (26.7 °C), subtract 0.004 from the reading.

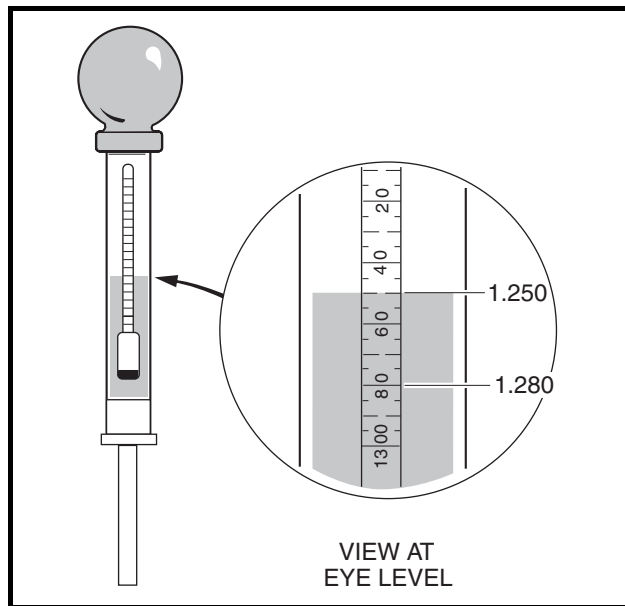


Figure 13-4 Hydrometer

Interpreting the Results of the Hydrometer Test

The approximate state of charge can be determined from the following table:

SPECIFIC GRAVITY (TEMPERATURE CORRECTED)	APPROXIMATE STATE OF CHARGE
1.250-1.280	100%
1.220-1.240	75%
1.190-1.210	50%
1.160-1.180	25%

If the difference between the cells is 0.020 or more, the low cell should be suspected. It may require a catch-up charge or it may be a weak cell. When the variations between cells reach 0.050 or more, the battery with the low cell should be replaced.

VEHICLE NO.	BATTERY NO.	ELECTROLYTE TEMPERATURE	CORRECTION FACTOR	CORRECTED SPECIFIC GRAVITY				REQUIRED ACTION
				CELL 1	CELL 2	CELL 3	CELL 4	
12	1	20 °F (-6.6 °C)	- 0.024	1.275 - 0.024 = 1.251	1.280 - 0.024 = 1.256	1.280 - 0.024 = 1.256	1.280 - 0.024 = 1.256	Sound battery - fully charged
35	6	90 °F (32.2 °C)	+ 0.004	1.155 + 0.004 = 1.159	1.165 + 0.004 = 1.169	1.160 + 0.004 = 1.164	1.165 - 0.004 = 1.169	Discharged battery - recharge
54	3	50 °F (10 °C)	- 0.012	1.260 - 0.012 = 1.248	1.200 - 0.012 = 1.188	1.270 - 0.012 = 1.258	1.270 - 0.012 = 1.258	Bad no. 2 cell
69	5	80 °F (26.7 °C)	0.000	1.250 - 0 = 1.250	1.255 - 0 = 1.255	1.230 - 0 = 1.230	1.250 - 0 = 1.250	Weak no. 3 cell - catch-up charge
38	2	100 °F (37.8 °C)	+ 0.008	1.200 + 0.008 = 1.208	1.180 + 0.008 = 1.188	1.170 + 0.008 = 1.178	1.180 + 0.008 = 1.188	Discharged battery - recharge and recheck
22	4	80 °F (26.7 °C)	0.000	1.240 - 0 = 1.240	1.245 - 0 = 1.245	Float does not rise	1.250 - 0 = 1.250	No.3 cell dead - replace battery

DISCHARGE TEST

If the previous tests have failed to identify the problem, conduct a discharge test. The discharge test comes closest to simulating actual vehicle operating conditions by continuously drawing current from the batteries until voltage drops to 42.0 volts.

The discharge test is the hardest test on the batteries and the most time-consuming to perform. Use the battery discharge tester (CCI P/N 101831901).

Performing the Discharge Test

1. Be sure the batteries are fully charged and that the electrolyte level is correct in all cells.
2. Connect the tester probes to the positive (+) post of battery no.1 and negative (-) post of battery no. 6 (Figure 13-5, Page 13-9).

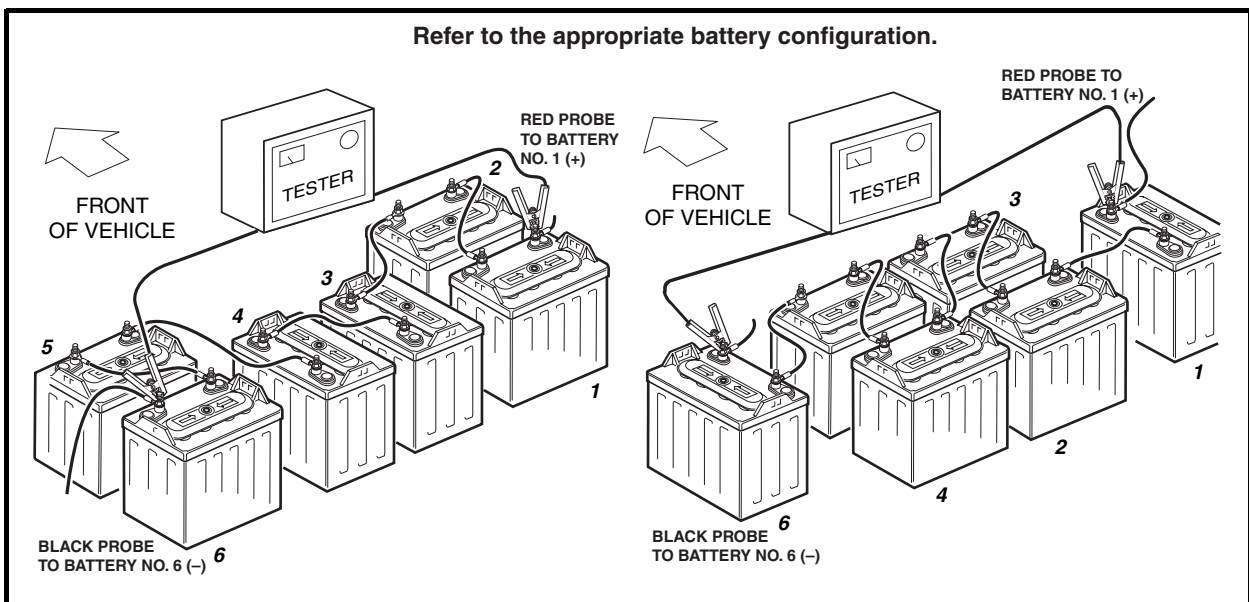


Figure 13-5 Battery Discharge Test

Performing the Discharge Test, Continued:

3. Check and record the electrolyte temperature of the battery packs. Check cell no. 2 (second cell from positive post) in each battery.
4. Reset discharge machine and turn the tester ON.
5. When the batteries have been discharging for approximately 60 minutes, set the discharge machine to function 3 and check battery set voltage. Check voltage every 10 minutes throughout the rest of the test. As soon as the battery set voltage reaches 0.5 volts above the shut-off point (42.0 volts), use a multimeter to measure individual battery voltages. Measure and record the voltage of each battery to the nearest 0.01 volt. **See following NOTE.**

NOTE: The tester will shut off automatically when shut-off voltage is reached.

Interpreting Discharge Test Results

1. If discharge time is 60 minutes or higher, the problem is not with the batteries.
2. If discharge times are low (less than 60 minutes), replace batteries below 6.7 volts.

BATTERY VOLTAGES						BATTERY CONDITION
1	2	3	4	5	6	
7.00 V	7.00 V	7.00 V	7.00 V	7.00 V	7.00 V	Excellent
7.07 V	7.07 V	7.22 V	6.50 V	7.07 V	7.07 V	Battery no. 4 is near end of useful life
7.20 V	7.20 V	6.67 V	7.33 V	6.27 V	7.33 V	Battery nos. 3 and 5 are near end of useful life

3. In general, battery sets that discharge in less than 60 minutes at 78 °F (25.6 °C) on the discharge test will typically not hold a charge for an entire work shift. However, discharge time is dependent on the electrolyte temperature. The table shown gives the discharge times, at various temperatures, of a set of batteries that delivers 62 minutes at 80 °F (26.7 °C).

ELECTROLYTE TEMPERATURE	DISCHARGE TIME TO SHUT-OFF POINT	ELECTROLYTE TEMPERATURE	DISCHARGE TIME TO SHUT-OFF POINT
40-49 °F (4-9 °C)	40 Minutes	85-89 °F (29-32 °C)	64 Minutes
50-59 °F (10-15 °C)	45 Minutes	89-99 °F (32-37 °C)	66 Minutes
60-64 °F (16-18 °C)	50 Minutes	100-109 °F (38-43 °C)	68 Minutes
65-69 °F (18-21 °C)	54 Minutes	110-119 °F (43-48 °C)	70 Minutes
70-74 °F (21-23 °C)	57 Minutes	120-129 °F (49-54 °C)	72 Minutes
75-79 °F (24-26 °C)	60 Minutes	130-150 °F (54-66 °C)	74 Minutes
80-84 °F (27-29 °C)	62 Minutes	*****	*****

BATTERY TROUBLESHOOTING EXAMPLES

The following information represents a few examples of troubleshooting battery problems.

Example 1

Vehicle no. 68 was suspected of having a bad battery due to its performance. As a result, the battery charger test was performed. After a full charge, the battery charger ammeter read 8.0 amps. Next, the on-charge voltage test was performed and the following results were recorded:

BATTERY NO.	1	2	3	4	5	6
On-Charge Voltage	10.15 V	10.60 V	9.80* V	10.16 V	10.56 V	10.61 V

*Battery no. 3 appears suspect. Battery nos. 1 and 4 are also suspect. Next, a hydrometer test should be conducted on all batteries.

Hydrometer test results:

CELL NUMBER	BATTERY NUMBER					
	1	2	3	4	5	6
Cell 1 (Positive Post)	1.200*	1.265	1.300	1.250	1.280	1.260
Cell 2	1.285	1.275	1.290	1.270	1.295	1.265
Cell 3	1.265	1.270	1.275	1.265	1.280	1.275
Cell 4 (Negative Post)	1.275	1.270	1.285	1.265	1.275	1.275

*After the hydrometer test, it appears that battery no. 1 is the problem. Next, the discharge test was performed.

Discharge test results:

BATTERY NO.	1	2	3	4	5	6
Discharge Voltage	5.44* V	7.33 V	7.73 V	7.15 V	7.43 V	7.41 V

*After a discharge test which lasted 45 minutes, battery no. 1 is clearly shown to be the problem. Battery no. 4 should be watched a little more closely but appears to be okay. Battery no. 1 should be replaced with a battery that has about the same age and usage as the other batteries in the set.

Example 2

Vehicle no. 70 was also suspected of having a bad battery due to its performance. The battery charger test showed 7.0 amps after a full charge. After confirming there were no problems with the electrical system, charger or brakes, the on-charge voltage was recorded as follows:

BATTERY NO.	1	2	3	4	5	6
On-Charge Voltage	10.48 V	9.77* V	10.53 V	10.57 V	10.55 V	10.33 V

*Battery no. 2 was immediately suspected as the problem. After checking battery no. 2 with a hydrometer, it was discovered that the negative (–) post cell was completely dead. Battery no. 2 should be replaced with a battery that has the same age and usage as the other batteries in the set.

BATTERY STORAGE

See General Warning, Section 10, Page 10-1.

When storing batteries during the off-season or when maintaining a replacement stock, follow these guidelines:

1. Keep the batteries clean and free of corrosion. **See Battery Care on page 13-2.**
2. Batteries that are in vehicles for winter storage should be left disconnected in the vehicles if the batteries are not going to be connected to a charger.
3. Fully charge the batteries prior to storage.
4. Store in a cool, dry place. The colder the area in which the batteries are stored, the less the batteries will self-discharge. Batteries stored at 0 °F (-17.8 °C) will discharge very little over a four-month period. Batteries stored at 80 °F (26.7 °C) will have to be recharged every few weeks.
5. 48-volt Club Car electric vehicles and compatible battery chargers are designed to be left connected, with AC power to the charger ON, during off-season storage. The PowerDrive storage charge feature will automatically charge the batteries as needed throughout the storage period.

CHARGING A BATTERY PACK THAT HAS LOW VOLTAGE

See the appropriate battery charger maintenance and service manual.

SECTION 14 – POWERDRIVE BATTERY CHARGER

Refer to the appropriate battery charger maintenance and service manual.

SECTION 15 – MOTOR

▲ DANGER

- See General Warning, Section 10, Page 10-1.

▲ WARNING

- See General Warning, Section 10, Page 10-1.

GENERAL INFORMATION

All PowerDrive electric vehicles are equipped with PowerDrive System 48 electrical systems which utilize 48-volt DC, series-wound, reversible traction motors. If the motor should require major repair, it should be sent to a qualified motor repair shop; however, there are many minor repairs that can be made by a trained technician.

EXTERNAL MOTOR TESTING

The following tests can be performed using a multimeter or continuity tester without disassembling the motor. See following NOTE.

NOTE: Tag the motor wires for identification before disconnecting.

TEST PROCEDURE 1 – INTERNAL SHORT CIRCUITS

See General Warning, Section 10, Page 10-1.

1. Disconnect the battery cables as instructed. See WARNING “To avoid unintentionally starting...” in General Warning, Section 10, Page 10-1.
2. Disconnect wires from terminals on motor using two wrenches to prevent the posts from turning.
3. Set a multimeter to 200 ohms. Place the black (–) probe on the motor housing. Scratch through the paint to ensure a good connection. Place the red (+) probe on the A1, A2, S1, and S2 terminals respectively. Multimeter should indicate no continuity between the motor housing and all individual terminals. If readings are incorrect, the motor will need to be removed from the vehicle and repaired by a qualified technician. See Motor Removal on page 15-2.
 - 3.1. An incorrect reading from the A1 or A2 terminal indicates three possible problems: a grounded A1 or A2 terminal, a grounded wire in the brush area, or a grounded armature/commutator. An incorrect reading for the S1 or S2 terminal indicates a possible grounded S1 or S2 terminal or field coil.

TEST PROCEDURE 2 – ARMATURE CIRCUIT OPEN

See General Warning, Section 10, Page 10-1.

1. Disconnect the battery cables as instructed. See WARNING “To avoid unintentionally starting...” in General Warning, Section 10, Page 10-1.

Test Procedure 2 – Armature Circuit Open, Continued:

2. Disconnect the wires from the A1 and A2 terminals on the motor using two wrenches to prevent posts from turning. Set a multimeter to 200 ohms and place the red (+) probe on the A1 motor terminal and black (-) probe on the A2 motor terminal. The multimeter should indicate continuity. If the reading is incorrect, a possible open or poor contact in a brush assembly and/or open armature windings may be the cause. The motor will need to be removed from the vehicle and repaired by a qualified technician. **See Motor Removal on page 15-2.**

TEST PROCEDURE 3 – FIELD CIRCUIT OPEN**See General Warning, Section 10, Page 10-1.**

1. Disconnect the battery cables as instructed. **See WARNING “To avoid unintentionally starting...” in General Warning, Section 10, Page 10-1.**
2. Disconnect the wires from the S1 and S2 terminals on the motor using two wrenches to prevent the posts from turning. Set a multimeter to 200 ohms and place the red (+) probe on the S1 terminal and the black (-) probe on the S2 terminal. The multimeter should indicate continuity. If the reading is incorrect, a possible open field coil or bad connections at the terminals may be the cause. The motor will need to be removed from the vehicle and repaired by a qualified technician. **See Motor Removal on page 15-2.**

MOTOR**See General Warning, Section 10, Page 10-1.****Motor Removal**

1. Disconnect the battery cables as instructed. **See WARNING “To avoid unintentionally starting...” in General Warning, Section 10, Page 10-1.**
2. Disconnect wires from terminals on motor using two wrenches to prevent the posts from turning. Label the wires to ensure proper reconnection.

For Villager vehicles, follow steps 3 through 8. For all other vehicles proceed to step 9:

3. Slightly loosen all the lug nuts on both rear wheels.
4. Place floor jack under transaxle and raise rear of vehicle (**Figure 15-1, Page 15-3**) then place jack stands under frame crossmember between the spring mount and the side stringer, just forward of each rear wheel. Lower the vehicle to let the jack stands support the vehicle (**Figure 15-2, Page 15-3**). **See following WARNING.**

 WARNING

- **Lift only one end of the vehicle at a time. Use a suitable lifting device (chain hoist or hydraulic floor jack) with 1000 lb. (454 kg) minimum lifting capacity. Do not use lifting device to hold vehicle in raised position. Use approved jack stands of proper weight capacity to support the vehicle and chock the wheels that remain on the floor. When not performing a test or service procedure that requires movement of the wheels, lock the brakes.**

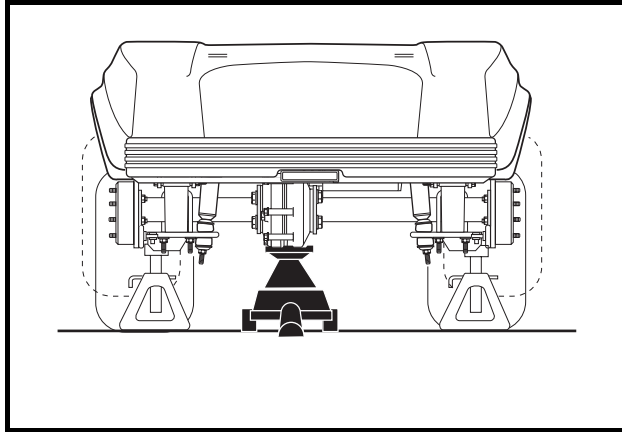


Figure 15-1 Lift Vehicle with Floor Jack

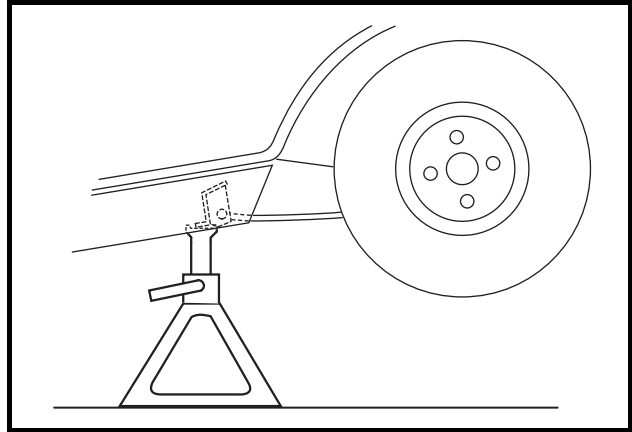


Figure 15-2 Vehicle Supported on Jack Stands

5. Remove both rear wheels.
6. Remove the nut, cup washer, and bushing from the bottom side of the shock absorber. Compress the shock absorber (pushing upwards) to move it out of the way (**Figure 15-3, Page 15-3**).
7. Remove the nuts and bolts mounting the rear leaf springs to the shackles.
8. To gain easier access to the motor, lower the transaxle as low as it will go. If more room is needed, remove the jack from beneath the transaxle and allow the springs to rest on the floor (**Figure 15-3, Page 15-3**).

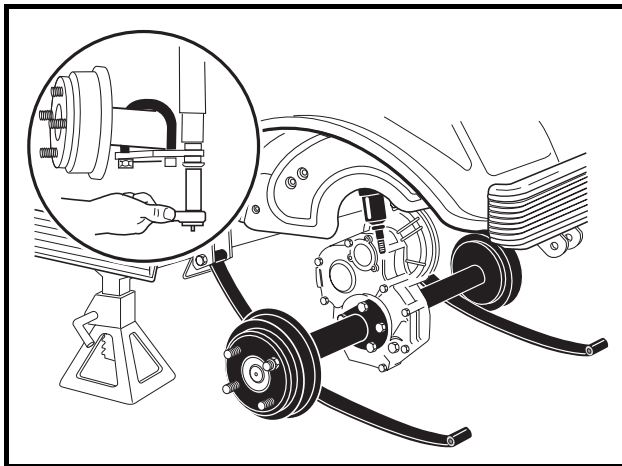


Figure 15-3 Transaxle Removal

9. Remove the four bolts that mount the motor to the transaxle (**Figure 15-18, Page 15-13**). See following **CAUTION**.

⚠ CAUTION

- Do not position fingers under motor when sliding motor off of the input shaft. Fingers may get pinched when motor disengages.

10. Carefully slide the motor away from the transaxle until the motor spline disengages the input shaft and remove the motor from the vehicle.

Motor Disassembly

1. Before beginning disassembly, place match marks on the motor end shield and stator shell, then place the motor in a vice with wooden blocks as shown (**Figure 15-4, Page 15-4**).
2. Remove the four bolts (8) securing the end shield (10) to the stator shell (2).
3. Remove the two screws (9) attaching the end shield to the bearing retainer.
4. Slide the armature (17) out of the opposite end of the stator shell (2).
5. Remove the two screws (11) attaching the brush rigging (12) to the stator shell (2) (**Figure 15-7, Page 15-7**).
6. Mark the brush terminal posts (A1 and A2) (27, 28) to identify their positions in the stator shell. Remove the nuts (6) and flat washers (5) (**Figure 15-7, Page 15-7**). From the outside, push the posts through the stator shell wall into the interior of the stator shell.
7. Carefully remove the brush rigging and the terminal posts from the stator shell.
8. To remove brush springs (14) from the rigging, lift the spring extensions out and over the brush mounts and then slide the springs off their mounting tabs (**Figure 15-5, Page 15-4**).

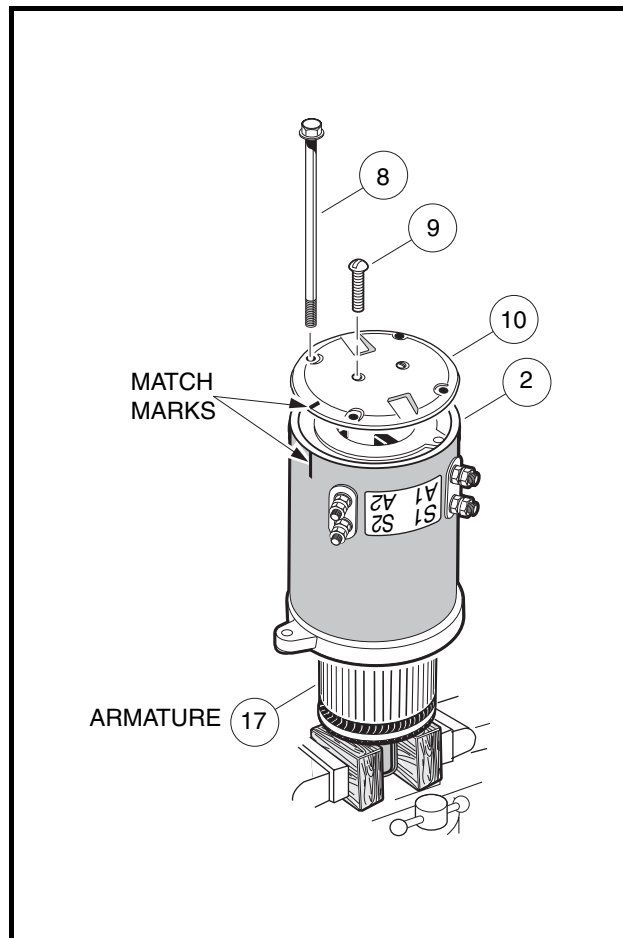


Figure 15-4 Motor Disassembly

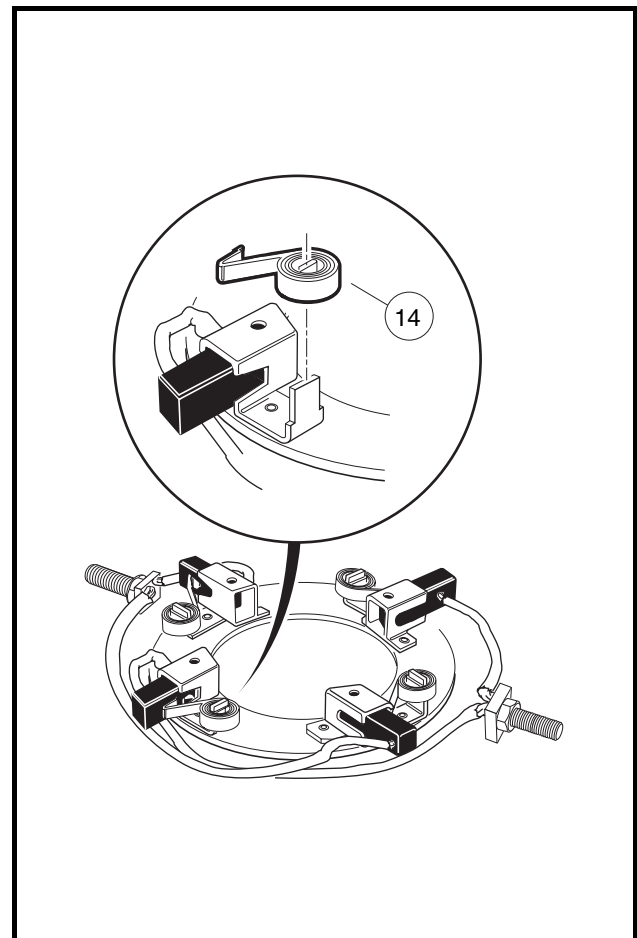


Figure 15-5 Brush Spring Removal

MOTOR COMPONENT TESTING AND INSPECTION

See General Warning, Section 10, Page 10-1.

ARMATURE

Visual Inspection

Disassemble the motor and carefully inspect the armature for the following characteristics:

- Burned, charred or cracked insulation
- Improperly cured varnish
- Thrown solder
- Flared armature windings
- Damaged armature core laminations
- Worn, burned or glazed commutators
- Dirty or oily commutators
- Raised commutator bars
- Worn armature bearing or shaft

A dirty or oily commutator should be cleaned and wiped dry. Abnormalities identified during the inspection can help determine original cause of failure. Slight roughness of the commutator can be polished smooth with 400 grit or finer sandpaper. **See following CAUTION and NOTE.**

CAUTION

- **Do not use emery cloth to polish the commutator. Particles of emery are conductive and may short-circuit the commutator bars. Do not use oil or lubricants on the commutator or brushes.**

NOTE: Oil on the commutator may indicate a faulty transaxle input shaft oil seal.

Armature Ground Test

CAUTION

- **Do not submerge the armature in solvent.**

NOTE: Before testing the armature, wipe it clean with a clean cloth. Remove any carbon dust and metal particles from between the commutator bars.

1. With a multimeter set to 200 ohms, place one probe on the commutator and the other on the armature core. The multimeter should indicate no continuity (**Figure 15-6, Page 15-6**). If the reading is incorrect, replace the armature.

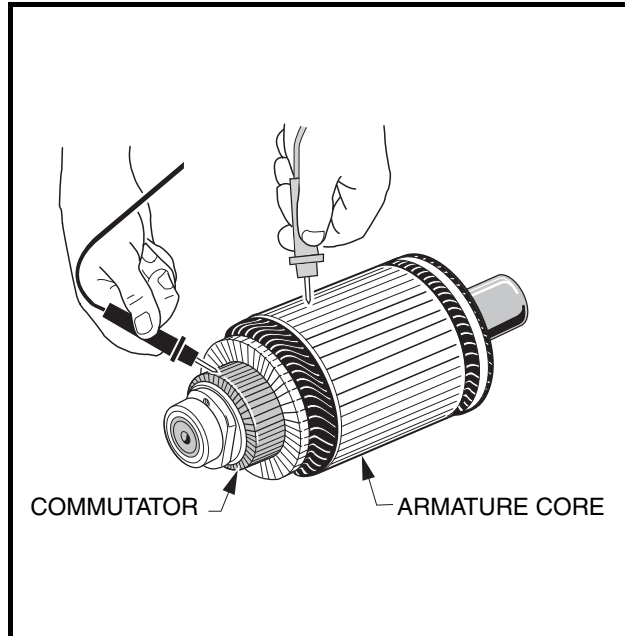


Figure 15-6 Armature

FIELD WINDINGS INSPECTION

Burned or scorched insulation on the field windings indicates the motor has overheated due to overloads or grounded or shorted coil windings. If the insulation on the field windings is scorched, replace the motor or the stator shell assembly.

MOTOR COMPONENTS

1. Inspect the insulators (4 and 7) for cracks or other damage (**Figure 15-7, Page 15-7**).
2. Inspect the brushes (13) for damage or excessive wear. Replace brushes if required. **See following NOTE.**
3. Inspect the brush springs (14) (**Figure 15-7, Page 15-7**). Replace springs that are discolored from heat (light gold or blue tinted). Replace springs which apply a force of less than 16 oz. (**Figure 15-8, Page 15-8**). **See following CAUTION.**

CAUTION

- **When checking brush spring tension, do not over-extend the spring. Using excessive force will damage the spring.**

NOTE: When installing new brushes, remove and replace brushes one at a time. This method ensures the terminals and brushes will be properly positioned in the rigging. Refer to Motor Assembly for brush installation. **See Motor Assembly on page 15-10.**

When replacing brushes, replace all four brushes. Never replace only two.

Install the brushes in the same rigging 180° apart from each other.

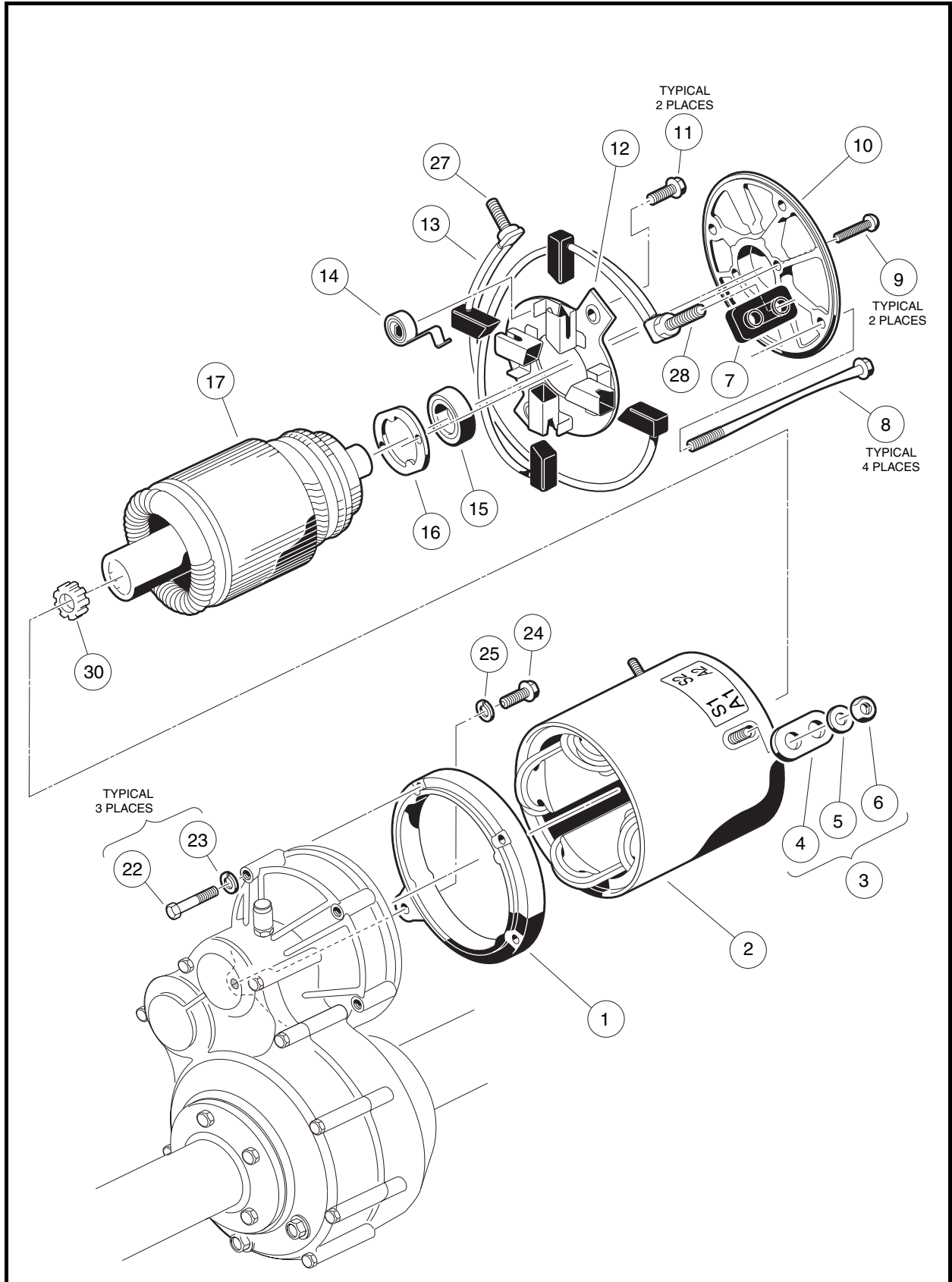


Figure 15-7 Motor

BEARING INSPECTION

1. Using a clean cloth, wipe the carbon dust off the bearing. Inspect the bearing by spinning it by hand and checking for both axial (A) and radial (B) play (**Figure 15-9, Page 15-8**).
2. Replace the bearing if it is noisy, does not spin smoothly, or has excessive play. Check the bearing and replace if rusted, worn, cracked, or if there is an abnormal color change in the metal of the bearing. Do not remove the bearing from the armature shaft unless it is to be replaced.

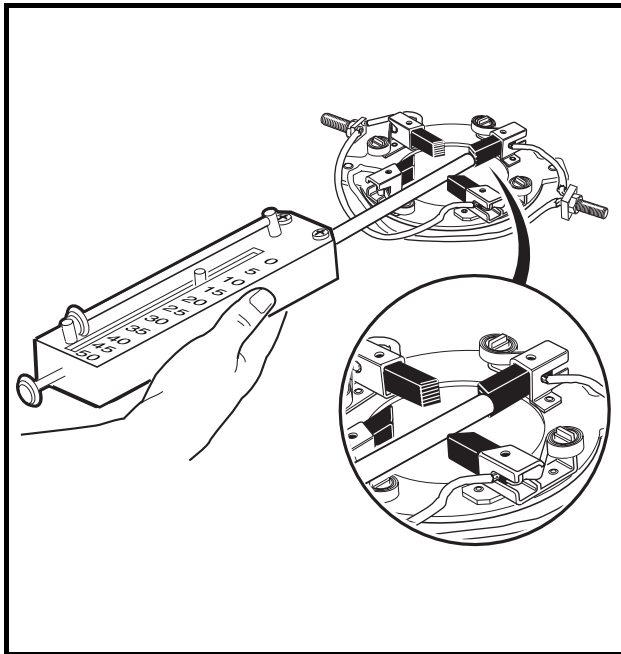


Figure 15-8 Brush Spring Tension Test

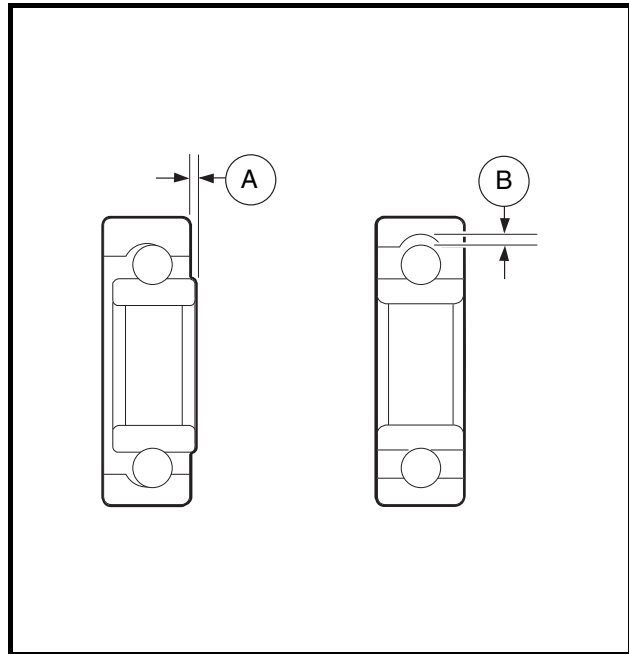


Figure 15-9 Bearing Inspection

BEARING REMOVAL

1. Place the wedge attachment tool (CCI P/N 1012812) between the bearing (15) and the armature (17) (**Figure 15-7, Page 15-7**). Make sure the wedge attachment tool is supporting the inner race of the bearing. If a press is not available, secure a bearing puller (CCI P/N 1012811) to the bearing and pull the bearing off of the end of the armature shaft. Support the shaft so it will not drop when the bearing is removed (**Figure 15-10, Page 15-9**). Discard the bearing.

BEARING INSTALLATION

1. Press a new bearing (15) onto the armature (**Figure 15-7, Page 15-7**). Use an arbor press that exerts pressure on the inner race only. **See following NOTE.**

NOTE: Make sure the bearing retainer (16) is positioned on the armature shaft before the bearing is pressed onto the armature (**Figure 15-7, Page 15-7**).

An arbor with an outside diameter of less than 5/8 inch (16 mm) should be used to press the bearing onto the armature.

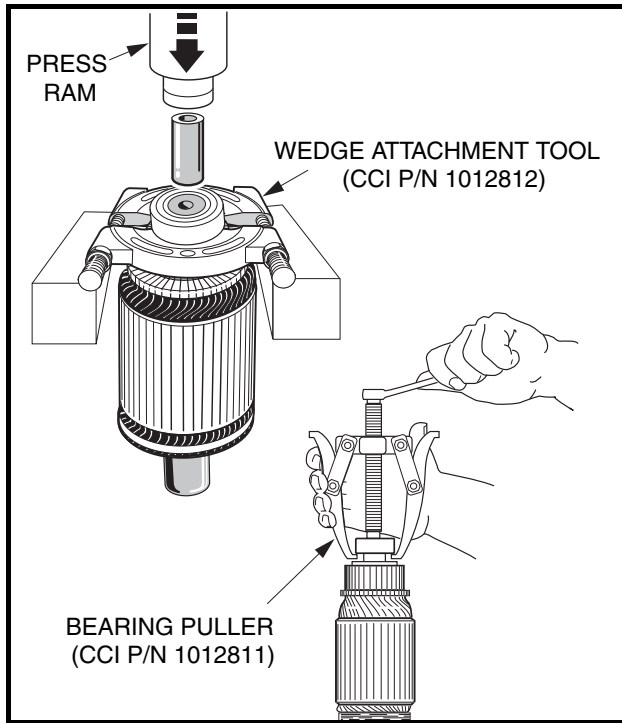


Figure 15-10 Bearing Removal

RECONDITIONING THE MOTOR

See General Warning, Section 10, Page 10-1.

Motor reconditioning must be performed by a qualified motor repair technician. The use of proper tools and procedures is absolutely essential for successful motor reconditioning.

Motor Specifications

Any rework must be performed by a qualified technician. Motor service specifications are listed in the following table.

ITEM	SERVICE LIMIT
Commutator diameter (minimum)	2.625 in. (66.675 mm)
Commutator concentric with armature shaft within	0.001 in. (0.0254 mm)
Limit depth of cut when machining commutator	0.005 in. (0.127 mm)
Bar to bar runout should not exceed	0.002 in. (0.00508 mm)
If undercut of segment insulator is less than 0.016 inch (0.406 mm), then it should be undercut to	0.031 in. (0.8 mm)
Machined face of commutator	8-16 microinches (203.2-406.4 nm)
Field coil resistance (PowerDrive System 48, 3.10 hp)	0.0204 ohms

MOTOR ASSEMBLY

See General Warning, Section 10, Page 10-1.

1. If the bearing has been removed, replace the bearing. See **Bearing Installation on page 15-8.**
2. Install the brushes. See following **NOTE.**

NOTE: When installing new brushes, remove and replace brushes one at a time. This method ensures the terminals and brushes will be properly positioned in the rigging.

When replacing brushes, replace all four brushes. Never replace only two.

Install the brushes in the same rigging 180° apart from each other.

- 2.1. With brush rigging facing down and held slightly above stator shell, insert the two terminal posts through the insulators in the stator shell wall at the A1 and A2 positions. Insert the brush holder screws through the holes in the brush rigging and into the threaded holes in the mounting bracket (**Figure 15-11, Page 15-10**). Tighten the screws to 20 in-lb (2.3 N·m).
- 2.2. One at a time, push brush spring extensions back from brushes and slide the brushes back until they are completely retracted into their mounting slots. Then position the brush springs against the sides of the brushes so that spring pressure will hold them in the retracted position (**Figure 15-5, Page 15-4**).
- 2.3. Slide the armature, bearing end first, into the stator shell. Make sure the brushes are held back while positioning the armature for proper commutator/brush contact. Release the brushes and place the springs outside the brushes so the brushes are being held against the commutator. See following **CAUTION.**

CAUTION

- If the motor is being assembled with the armature standing on end as the commutator is positioned, make sure the brushes are held back. Do not allow the brushes to support the weight of the stator shell. The brushes can be easily damaged by this weight.

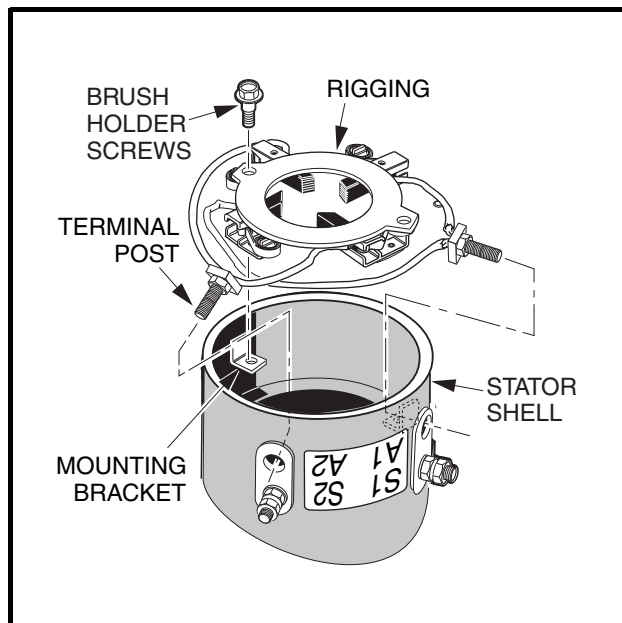


Figure 15-11 Brush Installation

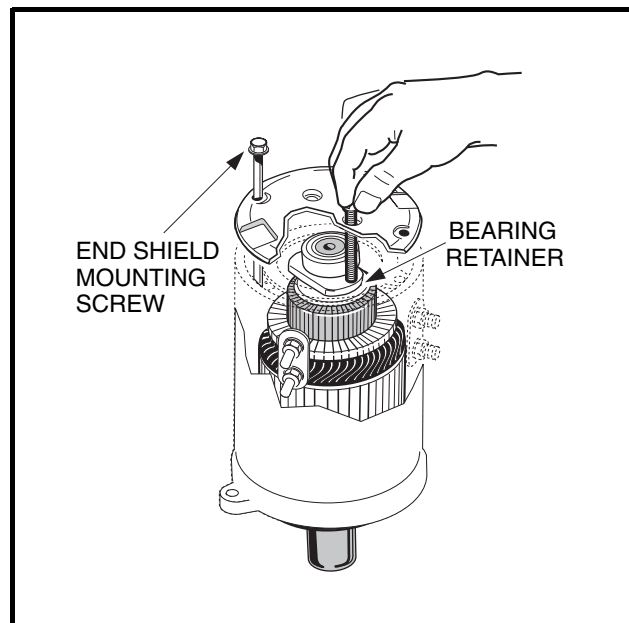


Figure 15-12 End Shield Installation

3. Install the end shield onto the stator shell.

3.1. Attach the end shield (10) to bearing retainer (16) by aligning the two holes in the bearing retainer with the two mating holes in the end shield and installing the screws (9) (**Figure 15-7, Page 15-7**). Tighten the screws to 17 in-lb (1.9 N·m). **See following NOTE.**

NOTE: Use a long screw with the same thread specifications as the mounting screws to maintain hole alignment while starting the first mounting screw (**Figure 15-12, Page 15-10**)

3.2. Align the match marks on the end shield and the stator shell, then install the four screws (8) (**Figure 15-7, Page 15-7**). Tighten the screws to 90 in-lb (10 N·m).

4. Make sure the armature turns freely. If it does not turn freely, disassemble the motor to find the problem. Make sure the bearing is properly seated in the end shield when assembling the motor.

MOTOR INSTALLATION

See General Warning, Section 10, Page 10-1.

1. Clean the transaxle input shaft.

- 1.1. Spray the input shaft thoroughly with CRC® Brakleen™ or equivalent brake cleaner degreaser.
- 1.2. Wipe input shaft with a clean cloth.
- 1.3. Inspect the grooves of the input shaft and remove any remaining debris.
- 1.4. Repeat steps 1.1 through 1.3 until input shaft is clean.

2. Lubricate the transaxle input shaft.

- 2.1. Squeeze approximately 1/2 inch (1.3 cm) of moly-teflon lubricant (CCI P/N 102243403) from tube onto a putty knife as shown (**Figure 15-13, Page 15-11**).
- 2.2. Rotate wheels to rotate input shaft.
- 2.3. Apply motor coupling grease evenly to the rotating input shaft starting at approximately 1/8 inch (3.1 mm) from the end of the shaft and working back toward the transaxle (away from the end of the shaft) (**Figure 15-14, Page 15-11**).

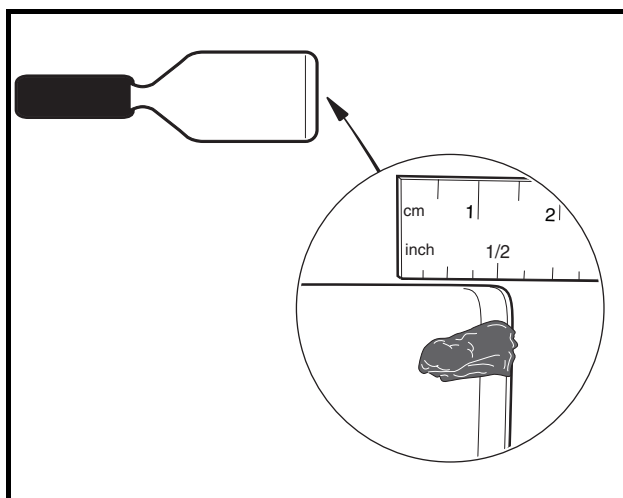


Figure 15-13 Grease on Putty Knife

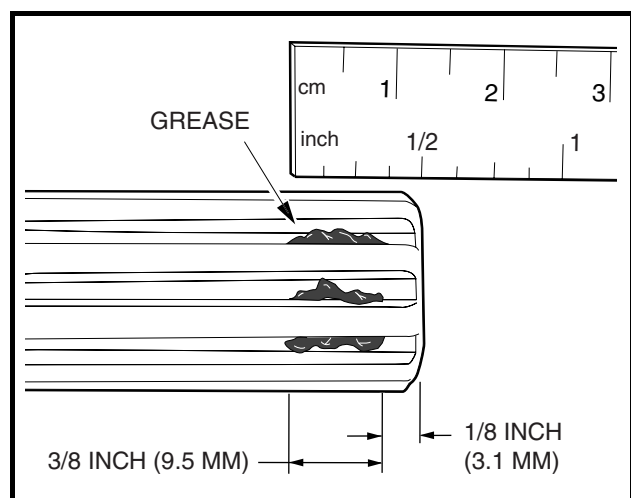


Figure 15-14 Application of Grease to Input Shaft Grooves

Test Procedure 3 – Field Circuit Open, Continued:

- 2.4. The grease should be evenly distributed in the grooves to a width of approximately 3/8 inch (9.5 mm).
 - 2.5. Use a flat screwdriver to clean the grease out of one of the grooves to allow air to escape when the motor is pushed onto the input shaft.
 - 2.6. Check the chamfer and end of the input shaft to ensure these areas are completely clean of grease as shown (**Figure 15-15, Page 15-12**).
3. Install the molded bumper.
 - 3.1. With the flat side toward the bottom of the coupling, install the molded bumper (30) into the motor coupling (**Figure 15-7, Page 15-7**). **See following NOTE.**

NOTE: The motor coupling and the new molded bumper must be new and free of grease and debris.

- 3.2. Ensure that the installed bumper is seated at the bottom of the coupling.
4. Install motor on transaxle.
 - 4.1. Slide the motor coupling onto the transaxle input shaft. **See following NOTE.**

NOTE: The coupling will push any excess grease on the input shaft along the shaft toward the transaxle.

When the motor is pushed onto the input shaft, the motor adapter ring (1) will not bottom out against the transaxle housing (**Figure 15-7, Page 15-7**). There will be approximately 1/16 inch (1.6 mm) gap between the motor adapter ring and transaxle housing as shown (**Figure 15-16, Page 15-12**).

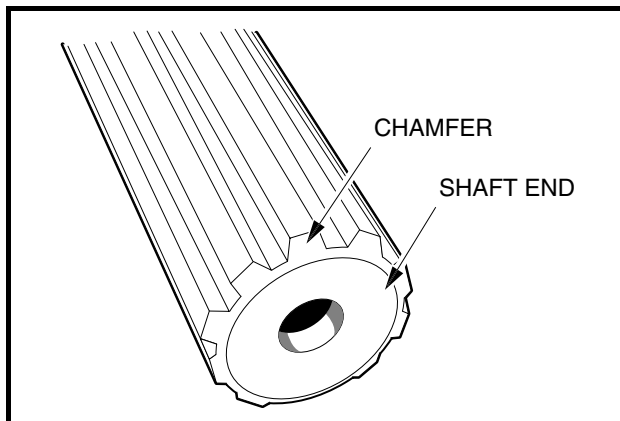


Figure 15-15 Clean Chamfer and Input Shaft End

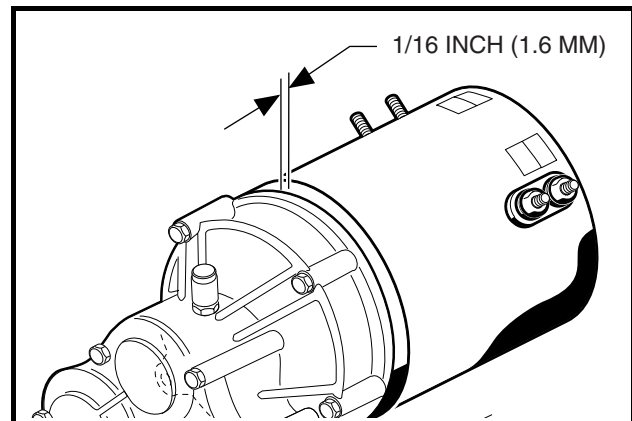


Figure 15-16 Gap at Motor and Transaxle

- 4.2. Loosely install four motor bolts and washers that secure the motor to the transaxle. Do not tighten.
- 4.3. Begin finger-tightening the bolts (1 and 2) in the sequence indicated (**Figure 15-18, Page 15-13**). Continue tightening by hand until the motor is seated in the transaxle housing. **See following CAUTION and NOTE.**

CAUTION

- Make sure the motor is properly seated in the transaxle housing.

NOTE: Failure to install and tighten the motor mounting bolts in the proper sequence and to the proper tightness may result in motor noise during operation.

- 4.4. Tighten the bolt (24) inserted through the tab to 155 in-lb (17.5 N·m) (**Figure 15-17, Page 15-13**).
- 4.5. Tighten the center bolt (2) to 65 in-lb (7.3 N·m) (**Figure 15-18, Page 15-13**).

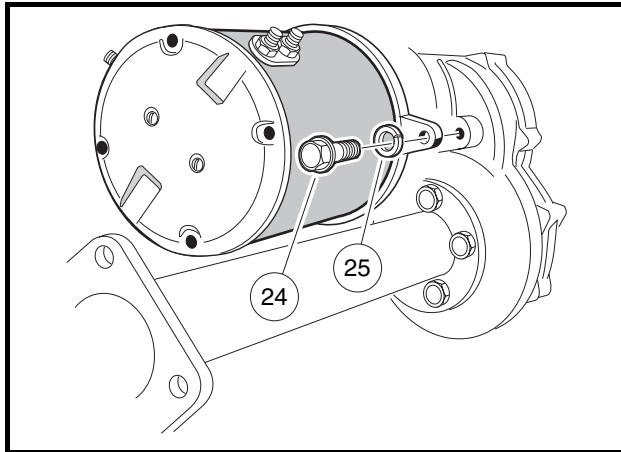


Figure 15-17 Motor Installation

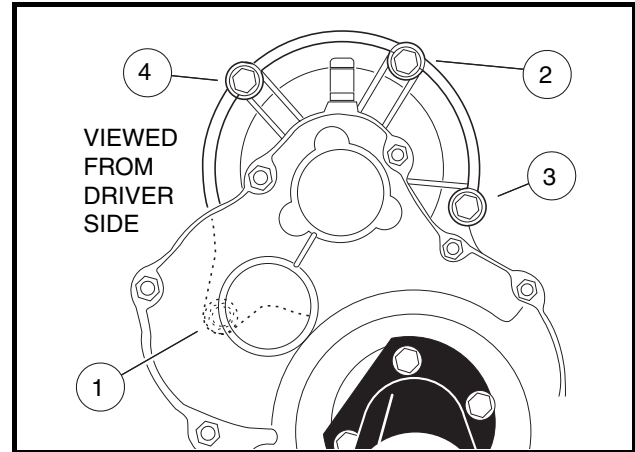


Figure 15-18 Motor Mount

- 4.6. Tighten the right bolt (3) to 65 in-lb (7.3 N·m).
- 4.7. Tighten the left bolt (4) to 65 in-lb (7.3 N·m).
- 4.8. Install the motor wires, making sure they are connected to the correct motor terminals and that the terminal orientation is correct. **See Wiring Diagrams, Section 11, Page 11-2.** Tighten the terminal retaining nuts to 65 in-lb (7.3 N·m).

For Villager vehicles, follow steps 5 through 9. For all other vehicles proceed to step 10:

5. If using a chain hoist, lower the vehicle and guide the leaf springs into the shackles. If using a floor jack, raise the transaxle until the leaf springs can be guided into the shackles.
6. Insert the mounting bolts through the spring shackles and the bushings in the leaf spring eyes and install locknuts. Tighten the bolts to 23 ft-lb. (31 N·m). **See Section 9 – Rear Suspension in the appropriate maintenance and service manual.**
7. Install the shock absorbers. Tighten nut until rubber bushing expands to the diameter of the cup washer.
8. Install the wheels and finger-tighten the lug nuts.
9. Lift vehicle and remove jack stands. Lower vehicle to the floor and tighten lug nuts, using a crisscross pattern, to 55 ft-lb (74.6 N·m).
10. Connect the batteries, positive (+) cable first. Tighten battery terminals to 110 in-lb (12.4 N·m) and coat terminals with Battery Terminal Protector Spray (CCI P/N 1014305) to minimize corrosion.
11. Inspect the vehicle for proper operation. **See following WARNING.**

⚠ WARNING

- **Make sure that the vehicle operates in the forward direction when the Forward/Reverse switch is in the FORWARD position.**
- **Make sure that the vehicle operates in the reverse direction when the Forward/Reverse switch is in the REVERSE position. The reverse buzzer will sound as a warning when the Forward/Reverse switch is in REVERSE.**
- **Make sure that the vehicle does not operate when the Forward/Reverse switch is in the NEUTRAL position.**

SECTION 16 – TRANSAXLE (TYPE G)

▲ DANGER

- See General Warning, Section 10, Page 10-1.

▲ WARNING

- See General Warning, Section 10, Page 10-1.

LUBRICATION

See General Warning, Section 10, Page 10-1.

There are two plugs located on the lower half of the transaxle housing. The upper plug (21) (as viewed when the vehicle is on a level surface) is used as a lubricant level indicator (**Figure 16-5, Page 16-3**). When the vehicle is parked on a level surface, the lubricant level should be even with the bottom of the hole. The lower plug (22) is for draining the lubricant. When draining the lubricant, the upper plug should be removed so the lubricant will drain faster. Be sure the drain plug is installed before filling. **See following NOTE.**

***NOTE:** Recycle or dispose of used oil or lubricant in accordance with local, state, and federal regulations.*

AXLE BEARING AND SHAFT

See General Warning, Section 10, Page 10-1.

AXLE SHAFT

Axle Shaft and Oil Seal Removal

1. Disconnect the battery cables as instructed. **See WARNING “To avoid unintentionally starting...” in General Warning, Section 10, Page 10-1.**
2. Place chocks at the front wheels. Loosen lug nuts on rear wheels and lift the rear of the vehicle with a chain hoist or floor jack. Place jack stands under the axle tubes to support the vehicle. **See WARNING “Lift only one end...” in General Warning, Section 10, Page 10-2.**
3. Remove the rear wheel and brake drum. **See Section 6 – Wheel Brake Assemblies and Section 8 – Wheels and Tires in the appropriate maintenance and service manual.**
4. Use 90° internal snap ring pliers to remove the internal retaining ring (6) from the axle tube (**Figure 16-5, Page 16-3**). **See also Figure 16-1, Page 16-2.**
5. Remove the axle, retaining ring, and bearing assembly by pulling the axle straight out of the housing.
6. If necessary, remove the axle oil seal and adapter ring.
 - 6.1. Use a bearing puller (CCI P/N 1016417) to remove the axle seal and adapter ring from the axle tube (**Figure 16-2, Page 16-2**). **See following CAUTION and NOTE.**

CAUTION

- **Do not scar or damage the inside surfaces of the tube when removing the oil seal and adapter ring. A damaged tube might have to be replaced.**

Axle Shaft and Oil Seal Removal, Continued:

NOTE: Do not discard the adapter ring. If the adapter ring is lost or damaged, the axle tube will have to be replaced.

- 6.2. Use a press to separate the axle oil seal (15) from the adapter ring (39) (**Figure 16-3, Page 16-2**). Retain the adapter ring and discard the oil seal.
7. Inspect the axle shaft assembly to be sure the bearing and collar have not slipped and are still seated against the shoulder on the axle shaft.
8. Inspect bearing (5) (**Figure 16-5, Page 16-3**). If the bearing in a Type G transaxle is worn or damaged, the entire axle shaft assembly (1 or 2) must be replaced.

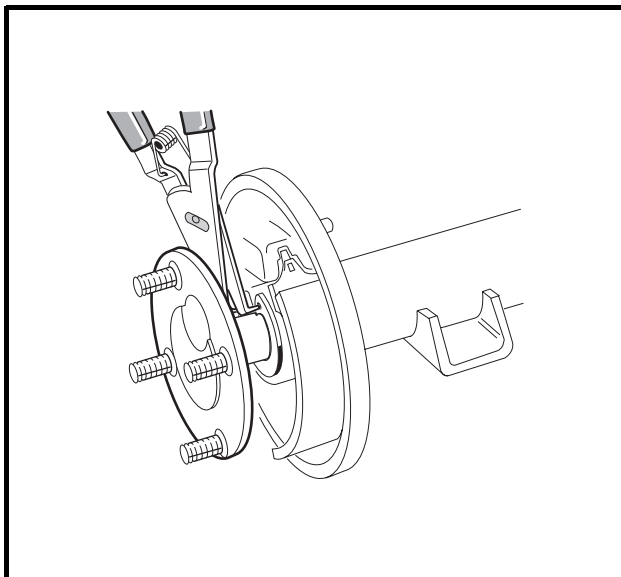


Figure 16-1 Axle Tube

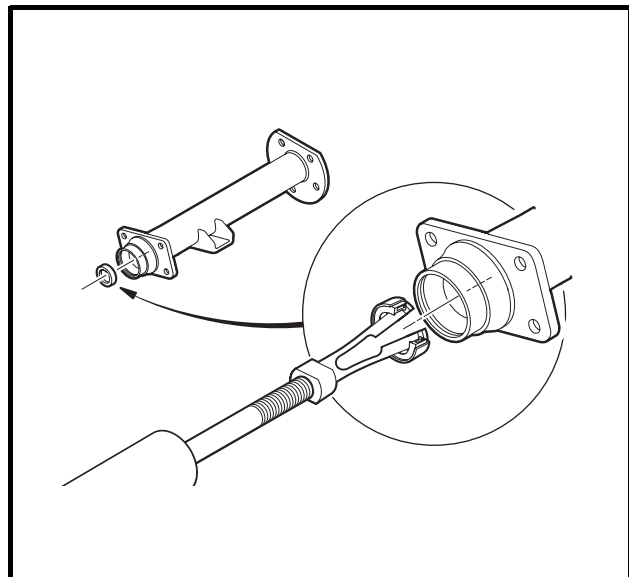


Figure 16-2 Axle Seal and Adapter Ring Removal

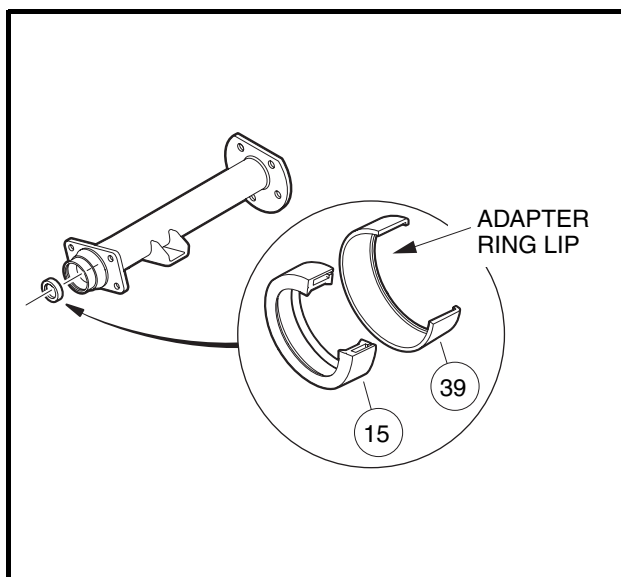


Figure 16-3 Axle Seal and Adapter Ring

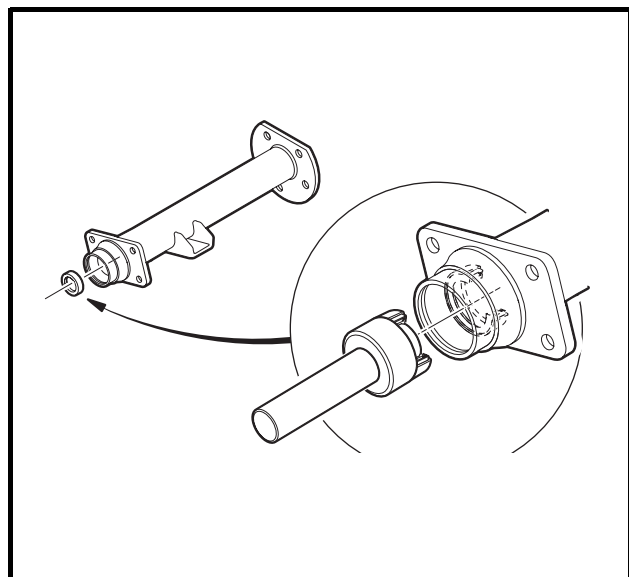


Figure 16-4 Axle Seal and Adapter Ring Installation

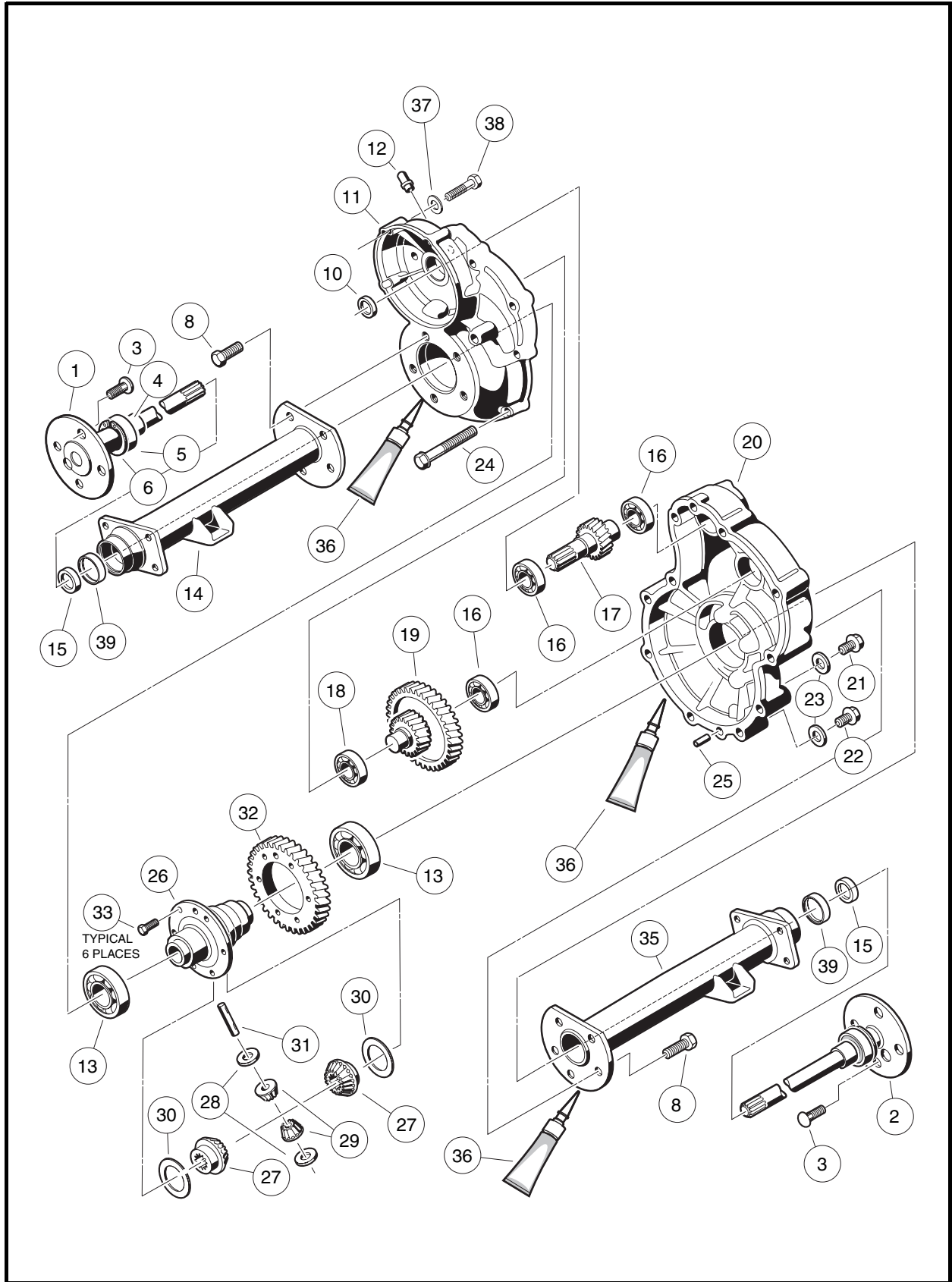


Figure 16-5 Transaxle – Type G

Axle Shaft and Oil Seal Installation

1. If previously removed, install a new oil seal.
 - 1.1. Clean seal seat in the adapter ring (39) (**Figure 16-3, Page 16-2**).
 - 1.2. Place a new seal (15) in the adapter ring with the seal lip facing toward the adapter ring lip (**Figure 16-3, Page 16-2**). Use an axle seal tool (CCI P/N 1014162) and mallet to tap it in until it seats firmly in position (**Figure 16-3, Page 16-2**). A hydraulic press may also be used with the axle seal tool.
 - 1.3. Clean adapter ring seat(s) in the axle tube (14 or 35) (**Figure 16-5, Page 16-3**).
 - 1.4. Apply Loctite[®] 603 to the outer diameter of the adapter ring.
 - 1.5. Place the oil seal and adapter ring assembly into the axle tube with the seal lip facing away from the bearing (**Figure 16-4, Page 16-2**). Use an axle seal tool (CCI P/N 1014162) and mallet to tap it in until it seats firmly in position. **See following CAUTION.**

CAUTION

- **Clean any residual oil from the exposed end of the axle shaft and from the oil seal area prior to installing the axle shaft to prevent oil from coming in contact with brakes.**
2. Install the rear axle into the transaxle. **See following NOTE.**
 - 2.1. Insert the shaft, splined end first, through the seal and into the axle tube. Be careful not to damage the seal on the inside of the axle tube hub. Advance the shaft through to the bearing on the shaft, then rotate it to align the shaft splines with the splined bore of the differential side gear (27) (**Figure 16-5, Page 16-3**). Continue advancing the shaft until the bearing on the axle is firmly seated within the axle tube hub seat.
 - 2.2. Use a pair of snap ring pliers to install the retaining ring (6) inside axle tube hub so that it seats against the axle bearing assembly and into the machined slot in the inside wall of the axle tube hub (**Figure 16-5, Page 16-3**). **See following NOTE.**
- NOTE:** *If the retaining ring (6), axle bearing (5), or sleeve (4) must be replaced, the entire axle shaft assembly (1 or 2) must be replaced (**Figure 16-5, Page 16-3**).*
- 2.3. Place a 1/4 to 3/8-inch (6 to 10 mm) diameter rod against the retaining ring and tap lightly at four to five locations around the retaining ring to ensure it is properly seated. **See following WARNING.**

WARNING

- **Be sure the retaining ring is properly seated in its groove. If the ring is not properly installed, the axle assembly will separate from the transaxle and damage the axle assembly and other components. Loss of vehicle control could result, causing severe personal injury or death.**
3. If a new oil seal was installed, allow 24 hours before operating the vehicle to allow the Loctite 603 to fully cure.

AXLE BEARING

Do not remove the axle bearing (5) from a Type G transaxle. If bearing is worn or damaged, the entire axle assembly (1 or 2) must be replaced (**Figure 16-5, Page 16-3**).

TRANSAXLE

See General Warning, Section 10, Page 10-1.

TRANSAXLE REMOVAL

1. Disconnect the battery cables as instructed. See **WARNING “To avoid unintentionally starting...”** in **General Warning, Section 10, Page 10-1.**
2. Place chocks at the front wheels and slightly loosen lug nuts on both rear wheels.
3. Place a floor jack under the transaxle and raise the rear of the vehicle. Position jack stands under the frame crossmember between the spring mount and the side stringer, just forward of each rear wheel. Lower the vehicle to let the jack stands support the vehicle (**Figure 16-6, Page 16-5**). See **WARNING “Lift only one end of the vehicle...”** in **General Warning, Section 10, Page 10-1.**
4. Remove the rear wheels, then thread one lug nut onto a stud on each rear hub. This will keep the brake drums on the hubs.
5. Remove the bow tie pins (1), brake cable clevis pins (2), and cable retaining E-clips (3). Disconnect the brake cables (4) (**Figure 16-7, Page 16-5**).

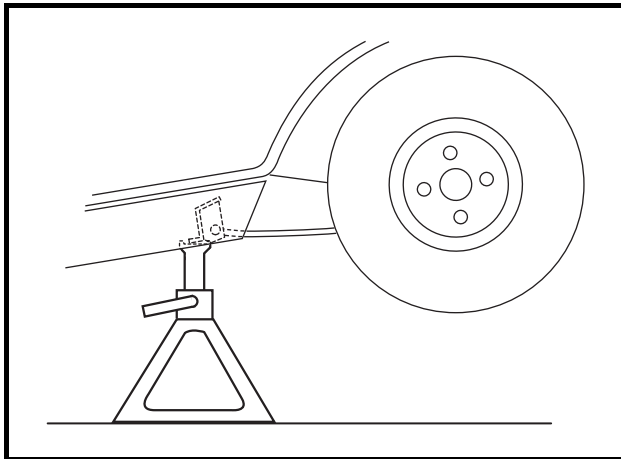


Figure 16-6 Vehicle Supported on Jack Stands

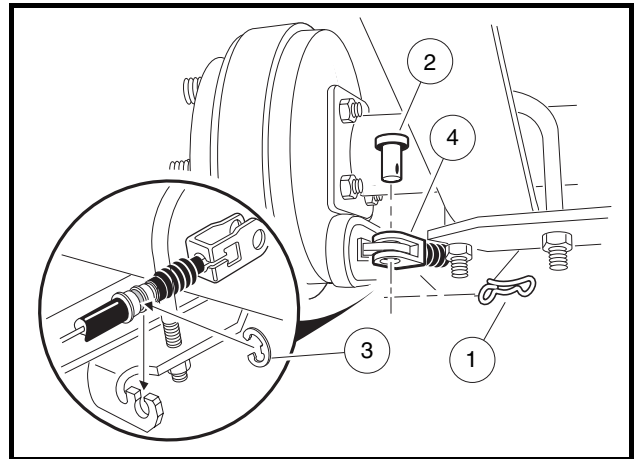


Figure 16-7 Brake Cables

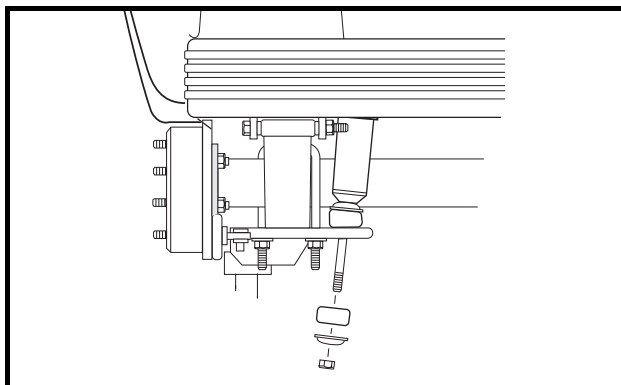


Figure 16-8 Disconnect Shocks

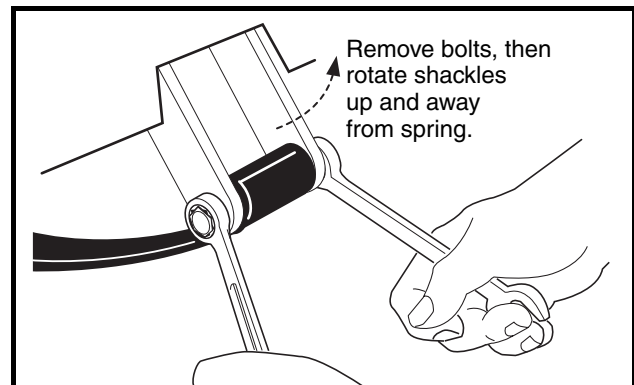


Figure 16-9 Shackles

6. Disconnect the shock absorbers from their lower mounts (**Figure 16-8, Page 16-5**).
7. Disconnect the four motor wires. Use two wrenches to prevent the post from turning.
8. With a floor jack supporting the transaxle, remove lower spring shackle nuts and bolts. Position shackles so they are clear of springs (**Figure 16-9, Page 16-5**).

Transaxle Removal, Continued:

9. If a chain hoist was used to raise the vehicle, lift the vehicle high enough to permit easy access and clearance for removal of the motor. If a floor jack was used to raise the vehicle, lower the transaxle enough to permit easy access and clearance for removal of the motor.
10. Remove the three motor mounting bolts (**Figure 16-11, Page 16-6**) and the motor positioning bolt (**Figure 16-12, Page 16-7**) mounting the motor to the transaxle. **See following CAUTION.**

⚠ CAUTION

- Do not position fingers under motor when sliding motor off of the input shaft. Fingers may get pinched when motor disengages.

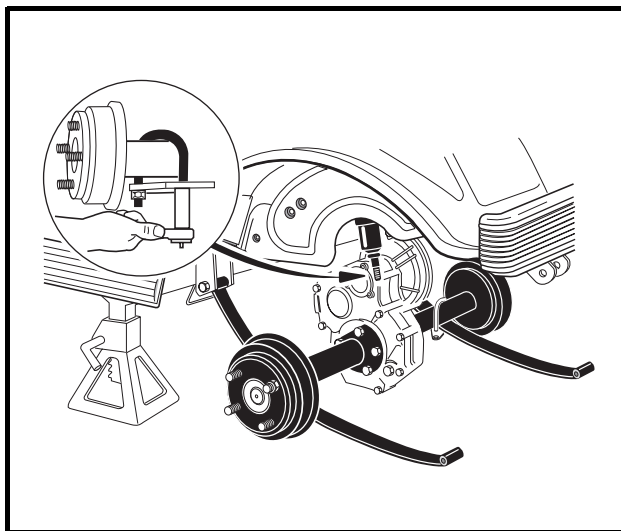


Figure 16-10 Leaf Springs

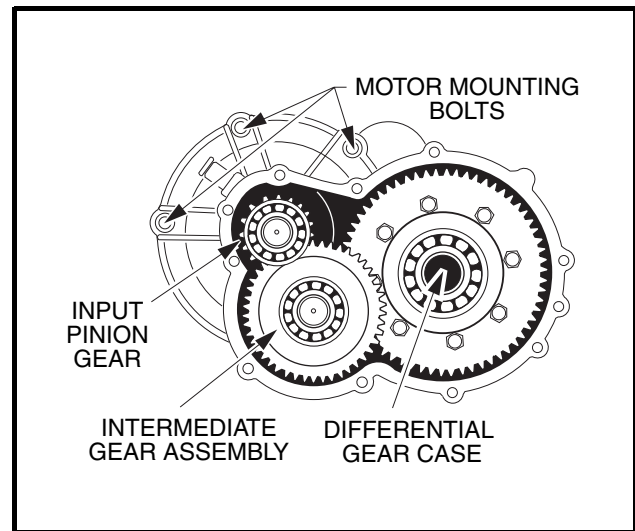


Figure 16-11 Motor Mounting Bolts

11. Carefully remove the motor from the transaxle. Slide the motor away from the transaxle until the motor spline becomes disengaged from the input shaft, then lift motor out. **See preceding WARNING.**
12. If a floor jack was used, pull floor jack from beneath the transaxle and allow the springs to rest on the floor.
13. Remove the U-bolts attaching the transaxle to the leaf springs (**Figure 16-10, Page 16-6**).
14. Carefully lift each end of the transaxle off its positioning pin (on the leaf spring) and slide the transaxle to the rear and out of the vehicle.
15. Drain the lubricant from the transaxle and remove the axle shafts. **See Axle Shaft and Oil Seal Removal on page 16-1. See following NOTE.**

NOTE: *Recycle or dispose of used oil or lubricant in accordance with local, state, and federal regulations.*

16. Remove the brake assemblies if required. **See Section 6 – Wheel Brake Assemblies in the appropriate maintenance and service manual.**

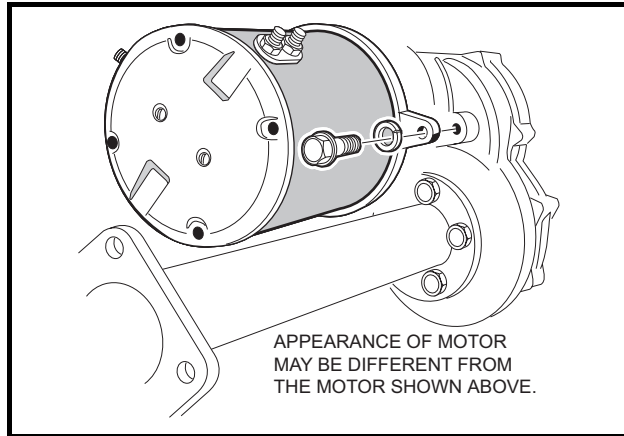


Figure 16-12 Motor Positioning Bolt

TRANSAXLE DISASSEMBLY, INSPECTION, AND ASSEMBLY

See General Warning, Section 10, Page 10-1.

TRANSAXLE DISASSEMBLY AND INSPECTION

1. To detach axle tubes (14 and 35) from the transaxle housing, remove the bolts (8) (**Figure 16-5, Page 16-3**).
2. Remove 11 bolts (24) that hold housing together.
3. Pull the halves of the housing (11 and 20) apart. If necessary, tap lightly on the spline of the input pinion (17). **See following CAUTION.**

CAUTION

- To prevent damage to the housing mating seal surfaces, use caution when separating halves.

4. Remove input pinion gear (17) by pulling gear out while rocking intermediate gear assembly (19). Lift intermediate gear assembly and differential gear case unit out simultaneously (**Figure 16-5, Page 16-3**). **See following CAUTION.**

CAUTION

- Do not damage gears. Use extreme care when handling them.

5. Use a bearing puller or arbor press to remove bearings (16) from the input pinion gear. If the oil seal (10) is damaged, replace it (**Figure 16-5, Page 16-3**). **See also Figure 16-13, Page 16-8. See following CAUTION.**

CAUTION

- Do not reuse bearings after removing them. Replace bearings with new ones.

6. To disassemble the intermediate gear assembly, press off together the bearing (16) and the gear (19) (**Figure 16-5, Page 16-3**). **See also Figure 16-13, Page 16-8.**

Transaxle Disassembly and Inspection, Continued:

7. Press the bearing (18) off the intermediate gear assembly (**Figure 16-5, Page 16-3**).

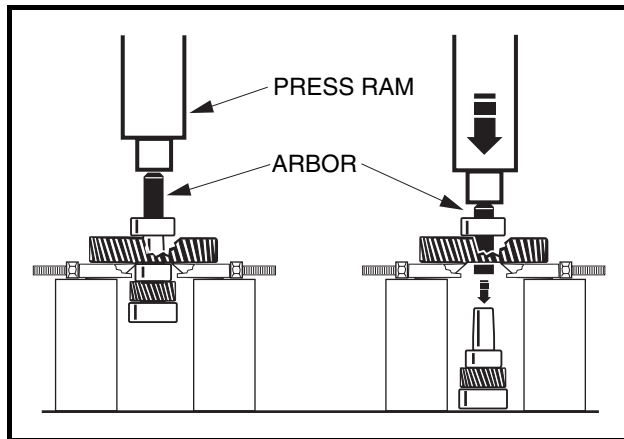


Figure 16-13 Intermediate Gear Assembly

8. Disassemble the differential gear case:
- 8.1. Remove the hex bolts (33) and the ring gear (32) from the differential case (**Figure 16-5, Page 16-3**).
 - 8.2. Remove the ring gear.
 - 8.3. Separate the differential gear case housing. If necessary, install two of the hex bolts (removed previously in step 8.1) into the differential gear unit and, while holding the unit slightly above the work area, lightly tap the bolt heads (**Figure 16-14, Page 16-8**). Remove the two bolts.

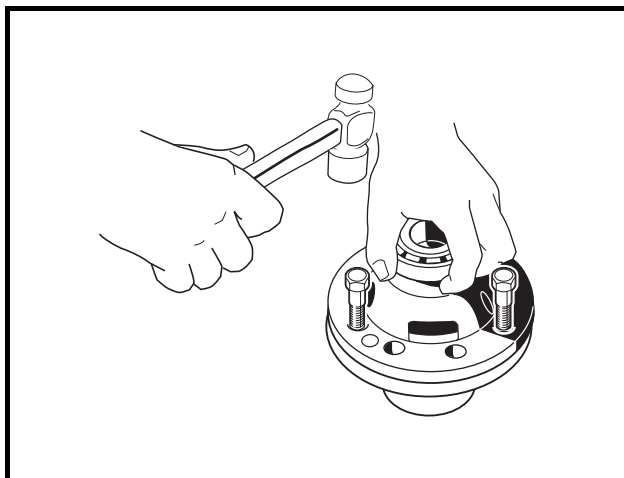


Figure 16-14 Separate Housing

- 8.4. Remove the differential pin (31) by pushing pin through differential gear case from one side (**Figure 16-5, Page 16-3**). See also **Figure 16-15, Page 16-9**.
- 8.5. Remove the idler gears and thrust plates (1 and 2) (**Figure 16-16, Page 16-9**).

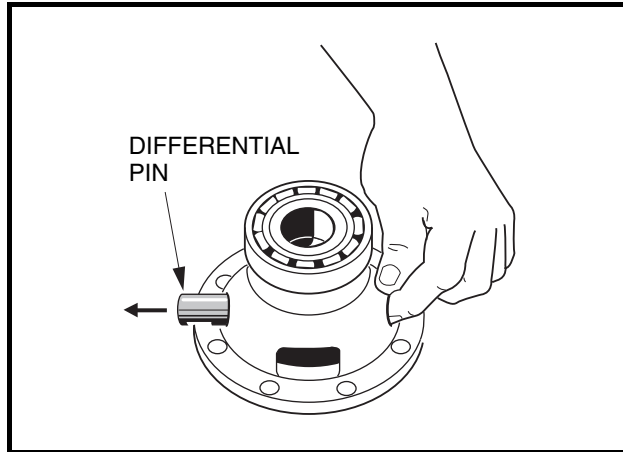


Figure 16-15 Differential Pin

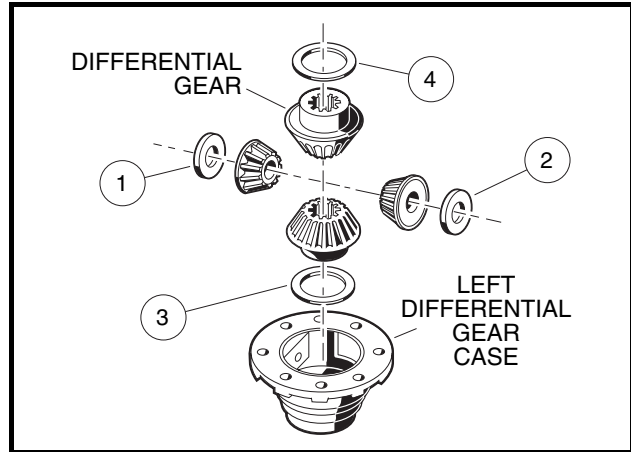


Figure 16-16 Left Differential

8.6. Remove the differential gears and thrust plates (3 and 4).

8.7. Inspect the bearings (13) of the differential case (26) and replace them if they are damaged (Figure 16-5, Page 16-3). To remove them, press them off. **See following CAUTION.**

CAUTION

- Do not reuse bearings after removing them. Replace bearings with new ones.

9. Inspect parts for wear or damage. Any worn or damaged parts should be replaced. **See following NOTE.**

NOTE: Damaged or worn gears should be replaced as sets.

TRANSAXLE ASSEMBLY

CAUTION

- Do not press against the bearing outer race.
- The housing and all parts must be wiped clean and dry before reassembly.

1. If bearings (13) were removed during disassembly, install new bearings using an arbor press (Figure 16-5, Page 16-3).
2. Assemble the differential gear case.
 - 2.1. Install the pin (31) (Figure 16-5, Page 16-3). Apply a small amount of oil to all thrust plates and to both ends of the pin.
 - 2.2. Install the hex bolts (33) and output gear (32). Tighten bolts to 58 ft-lb (78.6 N·m).
3. Press a new bearing (18) onto the intermediate gear assembly (Figure 16-5, Page 16-3).
4. Press new bearing (16) onto input pinion gear (17).
5. Apply grease to the lip of the new oil seal (10) and install the seal using a transaxle pinion seal tool (CCI P/N 1014161). The lip of the oil seal should face the inside of the transaxle housing. Make sure the seal is firmly seated.
6. Install the differential assembly, the intermediate gear assembly, and the input pinion gear simultaneously. Be sure all bearings are seated properly in the housing. Rotate the input shaft to check for smooth gear operation (Figure 16-11, Page 16-6).

Transaxle Assembly, Continued:

7. Install both dowel pins (25) in the transaxle housing (20) **(Figure 16-5, Page 16-3)**.
8. Install left half of transaxle housing:
 - 8.1. Place a 1/8-inch (3 mm) bead of Three Bond liquid gasket on mating surface of housing.
 - 8.2. Install left half of transaxle housing (20) **(Figure 16-5, Page 16-3)**.
 - 8.3. Install eleven bolts (24) in the case housing and tighten to 19 ft-lb (25.7 N·m). Type G transaxles have no shims or gasket.
 - 8.4. Install axle tube (14 and 35) with bolts (8) **(Figure 16-5, Page 16-3)**. Tighten the bolts to 37 ft-lb (50.2 N·m).
9. Install the brake assemblies as instructed. **See Section 6 – Wheel Brake Assemblies in the appropriate maintenance and service manual.**
10. Apply a small amount of grease to the lip of the oil seal (15) **(Figure 16-5, Page 16-3)**. **See following CAUTION.**

 CAUTION

- **Clean any residual oil from the exposed end of the axle shaft and from the oil seal area prior to installing the axle shaft to prevent oil from coming in contact with brakes.**

11. Install the rear axle onto the transaxle.
 - 11.1. Insert the splined end of the axle shaft into the axle tube. Be careful not to damage the seal on the inside of the axle tube hub. Advance the shaft through to the bearing on the shaft, and rotate it to align the shaft splines with the splined bore of the differential gear. Continue advancing the shaft until the bearing on the axle is firmly seated within the axle tube hub seat.
 - 11.2. Using 90° internal snap ring pliers (0.090 tip) (CCI P/N 1012560), attach the internal retaining ring into the axle tube hub so that it seats against the axle bearing assembly and into the machined slot in the inside wall of the axle tube hub **(Figure 16-5, Page 16-3)**.
 - 11.3. Place a 1/4 to 3/8-inch (6 to 10 mm) diameter rod against the retaining ring and tap lightly at four or five locations to ensure it is properly seated. **See following WARNING.**

 WARNING

- **Be sure retaining ring is properly seated in its groove. If ring is not properly installed, the axle assembly will separate from the transaxle and damage the axle assembly and other components. Loss of vehicle control could result in severe personal injury or death.**
12. Make sure the drain plug (22) is installed in the transaxle and tightened to 23 ft-lb (31 N·m). Fill the transaxle, through the level indicator hole, with 22 ounces of SAE 30 API Class SE, SF, or SG oil (a higher grade may also be used). Install and tighten the level indicator plug (21) to 23 ft-lb (31 N·m).

TRANSAXLE INSTALLATION

See General Warning, Section 10, Page 10-1.

1. If using a chain hoist, raise the vehicle and place transaxle in position on the jack stands. If using a floor jack, lower the jack stands to their lowest settings and place the transaxle in position on the jack stands.
2. Align the center hole in the saddle of the transaxle with the pilot bolt in the leaf spring assembly.

3. Install the two U-bolts, jounce bumper mount (if required), and spacers, lockwashers, and nuts. Tighten the nuts to 25 ft-lb (34 N·m). Tighten the U-bolt nuts so an equal amount of thread is visible on each leg of the bolt.
4. Install the motor. **See Section 15 – Motor.**
5. If using a chain hoist, lower the vehicle while guiding the leaf springs into the rear spring shackles. If using a floor jack, raise the differential while guiding the leaf springs into the rear spring shackles. Then raise the jack stands to support the transaxle.
6. Connect the four motor wires. Tighten the retaining nuts to 65 in-lb (7.3 N·m). Use two wrenches to prevent the posts from turning. **See following NOTE.**

NOTE: *If the motor wires were not tagged when disconnected, refer to the wiring diagram for proper connection. See Wiring Diagrams, Section 11, Page 11-2.*

7. Insert bolts through the spring shackles and bushings in the leaf spring eyes. Secure bolts with locknuts. Tighten to 15 ft-lb (20.3 N·m).
8. Connect the brake cables using new bow tie pins (1) (**Figure 16-7, Page 16-5**).
9. Install the shock absorbers. Tighten shock absorber retaining nuts until the rubber bushings expand to the same size as the cup washers.
10. Install the rear wheels and finger-tighten the lug nuts.
11. Lift the vehicle and remove the jack stands.
12. Lower vehicle and tighten the lug nuts, using a crisscross pattern, to 55 ft-lb (74.6 N·m).
13. Inspect the vehicle to check for proper operation. **See following WARNING.**

⚠ WARNING

- **Make sure that the vehicle operates in the forward direction when the Forward/Reverse switch is in the FORWARD position.**
- **Make sure that the vehicle operates in the reverse direction when the Forward/Reverse switch is in the REVERSE position. The reverse buzzer will sound as a warning when the Forward/Reverse switch is in REVERSE.**
- **Make sure that the vehicle does not operate when the Forward/Reverse switch is in the NEUTRAL position.**

A**armature, motor**

see motor, armature

B**batteries** 13-1

see also battery charger

care 13-2

charging 13-4

deep discharge 13-5

electrolyte

adding water (mineral content) 13-4

level 13-3

excessive early discharging 13-5

fleet rotation 13-5

hydrometer calibration 13-8

maintenance, preventive 13-2

see also batteries, electrolyte

replacement 13-1

self-discharge 13-3

storage 13-12

testing 11-16, 13-7

discharge test 13-9

interpreting test results 13-10

hydrometer test 13-7

interpreting test results 13-8

on-charge voltage test 13-7

troubleshooting examples 13-11

vibration damage 13-4

battery charger

16 hour shut-off 13-4

AC service, incoming 13-5

numbering vehicles and chargers 13-5

receptacle testing 11-27

battery condition indicator

installation 12-3

removal 12-3

testing 11-43

battery warning light

installation 12-22

removal 12-22

testing 11-27

bearing, axle

see transaxle, type g, axle bearing

bearing, motor

see motor, bearing

brake light relay

installation 12-20

removal 12-20

testing 11-33

brake pedal limit switch

installation 12-18

removal 12-18

testing 11-40

C**CDM**

see communication display module

charger receptacle

fuse link 12-15

installation 12-15

removal 12-15

installation 12-15

removal 12-14

testing 11-27

communication display module (CDM) 11-45

retrieving data from 11-47

troubleshooting 11-47

condition indicator, battery

see battery condition indicator

D**diode, solenoid** 12-9

removal 12-9

testing 11-18

drive motor

see motor

E**electric motor**

see motor

electrical system 11-1

circuits

circuit testing 11-15

F**forward/reverse limit switch** 12-5

installation 12-6

removal 12-6

testing 11-17

forward/reverse limit switch, half-speed

testing 11-27

forward/reverse switch

inspection 12-3

installation 12-4

removal 12-4

testing 11-19

H**half-speed resistor**

installation 12-7

removal 12-6
 testing 11-28

headlight
 socket testing 11-39

horn
 installation 12-23
 removal 12-23
 testing 11-43

horn switch
 installation 12-24
 removal 12-24
 testing 11-42

hour meter
 installation 12-25
 removal 12-25
 testing 11-44

I

inspection
 motor
 armature 15-5
 armature ground test 15-5
 bearing 15-8
 field windings 15-6
 motor components 15-6
 transaxle, type g 16-7

K

key switch
 installation 12-2
 removal 12-1
 testing 11-16

L

light switch
 installation 12-21
 removal 12-21
 testing 11-32

light, battery warning
 see battery warning light

limit switch, brake pedal
 see brake pedal limit switch

limit switch, park brake pedal
 see park brake pedal limit switch

limiter, voltage
 see voltage limiter

lubrication
 periodic lubrication schedule 10-5
 transaxle, type g 16-1

M

maintenance
 batteries 13-2
 periodic lubrication schedule 10-5
 periodic service schedule 10-3

meter, hour
 see hour meter

motor 15-1
 armature ground test 15-5
 armature inspection 15-5
 assembly 15-10
 bearing
 inspection 15-8
 installation 15-8
 removal 15-8
 component inspection 15-6
 disassembly 15-4
 field winding inspection 15-6
 installation 15-11
 reconditioning 15-9
 removal 15-2
 service specifications 15-9
 testing
 see test procedures, motor

motor controller output regulator (MCOR)
 installation 12-16
 removal 12-15
 testing 11-21, 12-15

O

onboard computer (OBC)
 installation 12-13
 removal 12-11
 retrieving data from 11-47
 testing 11-26

P

park brake pedal limit switch
 installation 12-19
 removal 12-19
 testing 11-41

periodic lubrication schedule 10-5
periodic service schedule 10-3

R

receptacle
 see charger receptacle

relay, brake light
 see brake light relay

resistor, solenoid 12-10
 installation 12-10

- removal 12-10
 testing 11-20
- reverse buzzer** 12-7
 see also electrical system, circuits, reverse buzzer
 circuit testing 11-29, 11-30
 installation 12-8
 removal 12-7
 testing 11-29
- reverse buzzer limit switch**
 testing 11-29
- S**
- service schedule**
 see periodic service schedule
 see also periodic lubrication schedule
- socket, headlight**
 see headlight
- socket, taillight**
 see taillight
- solenoid** 12-8
 see also diode, solenoid
 see also resistor, solenoid
 installation 12-9
 removal 12-8
 testing 11-18, 11-20
- speed controller**
 installation 12-13
 removal 12-13
 testing 11-24
- switch, headlight**
 see light switch
- switch, horn**
 see horn switch
- switch, limit, brake pedal**
 see brake pedal limit switch
- switch, limit, park brake pedal**
 see park brake pedal limit switch
- T**
- taillight**
 socket testing 11-38, 11-39
- test procedures**
 1 – batteries/voltage check 11-16
 2 – key switch 11-16
 3 – forward/reverse limit switch 11-17
 4 – solenoid activating coil 11-18
 5 – forward/reverse switch 11-19
 6 – solenoid contacts 11-20
 7 – MCOR 11-21
 8 – speed controller 11-24
 9 – onboard computer lockout circuit 11-26
 10 – battery warning light 11-27
 11 – charger receptacle 11-27
 12 – half-speed reverse limit switch 11-27
 13 – half-speed reverse resistor 11-28
 14 – reverse buzzer limit switch 11-29
 15 – reverse buzzer wire connections 11-29
 16 – wire continuity 11-30
 17 – battery voltage supply 11-30
 18 – light switch 11-32
 19 – brake light relay 11-33
 20 – voltage limiter 11-37
 21 – voltage at taillight socket 11-38
 22 – taillight bulb socket 11-39
 23 – voltage at headlight socket 11-39
 24 – brake pedal limit switch 11-40
 25 – park brake pedal limit switch 11-41
 26 – horn switch 11-42
 27 – voltage at horn 11-43
 28 – battery condition indicator 11-43
 29 – hour meter 11-44
- test procedures, motor**
 1 – internal short circuits 15-1
 2 – armature circuit open 15-1
 3 – field circuit open 15-2
 armature ground test 15-5
- transaxle, type g**
 assembly 16-9
 axle bearing 16-4
 axle shaft
 installation 16-4
 removal 16-1
 disassembly 16-7
 inspection 16-7
 installation 16-10
 lubrication 16-1
 oil seal
 installation 16-4
 removal 16-1
 removal 16-5
- troubleshooting**
 battery troubleshooting examples 13-11
 communication display module (CDM) 11-47
 troubleshooting guide 11-12
- V**
- voltage limiter**
 installation 12-17
 removal 12-17
 testing 11-37

W

warning light, battery

see battery warning light

water level

see batteries, electrolyte level

Your Comments Are Appreciated

Please select your category:

Distributor/Dealer

Technician

Individual Owner

Golf Course Superintendent

Other: _____

In order to help us better serve you, please rate this publication in the following categories:

	Poor	Fair	Average	Good	Excellent
1. Ease of Understanding	<input type="checkbox"/>	<input type="checkbox"/>	<input type="checkbox"/>	<input type="checkbox"/>	<input type="checkbox"/>
2. Ease of Finding Information	<input type="checkbox"/>	<input type="checkbox"/>	<input type="checkbox"/>	<input type="checkbox"/>	<input type="checkbox"/>
3. Clarity of Illustrations	<input type="checkbox"/>	<input type="checkbox"/>	<input type="checkbox"/>	<input type="checkbox"/>	<input type="checkbox"/>
4. Index Usability	<input type="checkbox"/>	<input type="checkbox"/>	<input type="checkbox"/>	<input type="checkbox"/>	<input type="checkbox"/>
5. Troubleshooting Chart Usability	<input type="checkbox"/>	<input type="checkbox"/>	<input type="checkbox"/>	<input type="checkbox"/>	<input type="checkbox"/>

Comments/Suggestions:

Please fax a copy of this page to (706) 228-2662.

Thank You!
Club Car Technical Publications Department



Club Car, Inc.
P.O. Box 204658
Augusta, GA 30917-4658
USA

Web www.clubcar.com
Phone 1.706.863.3000
1.800.ClubCar
Int'l +1 706.863.3000
Fax 1.706.863.5808