

G20A MULTI-PASSENGER SERVICE MANUAL SUPPLEMENT

FOREWORD

This Supplement Service Manual has been prepared to introduce new service and new data for the G20A Multi-Passenger vehicle. For complete information on service procedures, it is necessary to use this Supplement Service Manual together with following manuals:

**G14A/G14E
SERVICE MANUAL**

**G16A/G16E
SERVICE MANUAL SUPPLEMENT**

**G20A
SERVICE MANUAL SUPPLEMENT
1999 by Yamaha Motor Manufacturing
Corporation of America
1st edition, August 1999
Printed in U.S.A.
P/N/ LIT-19616-00-00**

INTRODUCTION

This manual has been written by Yamaha Motor Manufacturing Corporation of America for use by Authorized Yamaha dealers and their qualified mechanics. It is not possible to put an entire mechanic's education into a manual, so it is assumed that persons using this book to perform maintenance and repairs on Yamaha golf cars have a basic understanding of the mechanical concepts and procedures inherent to these products. Without such knowledge, attempted repairs or service to this golf car may render it unfit to use and/or unsafe.

Yamaha Motor Manufacturing Corporation of America is continually striving to further improve all models manufactured by the company. Modifications are therefore inevitable and will, where applicable, appear in future editions of this manual.

**TECHNICAL SERVICE DEPT
GOLF CAR SALES GROUP
YAMAHA MOTOR
MANUFACTURING CORP OF
AMERICA**

HOW TO USE THIS MANUAL

Read This Important Information!

Particularly important information in this manual is distinguished by the following notations:



The Safety Alert Symbol means **ATTENTION! BE ALERT! YOUR SAFETY IS INVOLVED!**

! WARNING

Failure to follow WARNING instructions could result in severe injury or death to golf car occupants, a bystander, or a person inspecting or repairing the golf car.

CAUTION

This message describes special precautions that must be taken to avoid damage to the golf car.

NOTE:

This message provides additional key information.

MANUAL FORMAT























All of the procedures in this manual are organized in a sequential, step-by-step format. The information has been compiled to provide the mechanic with an easy to read, handy reference that contains comprehensive explanations of all disassembly, repair, assembly, and inspection operations.

In this revised format, the condition of a faulty component will precede an arrow symbol and the course of action required will follow the symbol, e.g.,

- Bearings
Pitting/Damage → Replace.

EXPLODED DIAGRAM

Each chapter provides exploded diagrams before each disassembly section for ease of identifying correct disassembly and assembly procedures.

<p>①</p> <p>GEN INFO</p>  <p>ICON #1</p>	<p>②</p> <p>INSP ADJ</p>  <p>ICON #2</p>	
<p>③</p> <p>CHAS</p>  <p>ICON #3</p>	<p>④</p> <p>POWR TR</p>  <p>ICON #4</p>	
<p>⑤</p> <p>ENG</p>  <p>ICON #5</p>	<p>⑥</p> <p>CARB</p>  <p>ICON #6</p>	
<p>⑦</p> <p>ELEC</p>  <p>ICON #7</p>	<p>⑧</p> <p>TRBL SHTG</p> <p>?</p> <p>ICON #8</p>	
<p>⑨</p> <p>SPEC</p>  <p>ICON #9</p>		
<p>⑩</p>  <p>ICON #10</p>	<p>⑪</p>  <p>ICON #11</p>	
<p>⑫</p>  <p>ICON #12</p>	<p>⑬</p>  <p>ICON #13</p>	
<p>⑭</p>  <p>ICON #14</p>	<p>⑮</p>  <p>ICON #15</p>	
<p>⑯</p>  <p>ICON #16</p>	<p>⑰</p>  <p>ICON #17</p>	
<p>⑱</p> 	<p>⑲</p> 	<p>⑳</p>  <p>ICON #18 thru #20</p>
<p>㉑</p> 	<p>㉒</p> 	<p>㉓</p>  <p>ICON #21 thru #23</p>

Symbol Identification

Symbols ① to ⑨ are designed as thumb tabs to indicate the contents within a chapter.

- ① General information
- ② Periodic inspection and adjustment
- ③ Chassis
- ④ Power train
- ⑤ Engine overhaul
- ⑥ Carburetion
- ⑦ Electrical
- ⑧ Troubleshooting
- ⑨ Specifications

Symbols ⑩ to ⑯ are used to identify specifications within the text.

- ⑩ Filling fluid
- ⑪ Lubricant
- ⑫ Special tool
- ⑬ Tightening torque
- ⑭ Wear limit, clearance
- ⑮ Engine speed
- ⑯ Ω , V, A

Symbols ⑰ to ⑳ are used in the exploded diagrams to indicate the grade and location of lubricant.

- ⑰ Apply locking agent
- ⑱ Apply engine oil
- ⑲ Apply gear oil
- ⑳ Apply molybdenum disulfide oil
- ㉑ Apply wheel bearing grease
- ㉒ Apply lightweight lithium soap base grease
- ㉓ Apply molybdenum disulfide grease

INDEX









GENERAL INFORMATION	(Refer to G16A/E Service Manual Supplement)	
		GEN INFO 1
PERIODIC INSPECTION AND ADJUSTMENT	(Refer to G16A/E Service Manual Supplement)	
		INSP ADJ 2
CHASSIS	(Refer to G14A, G14E Service Manual)	
		CHAS 3
POWER TRAIN	(Refer to G16A/E Service Manual Supplement)	
		POWR TR 4
ENGINE OVERHAUL	(Refer to G16A/E Service Manual Supplement)	
		ENG 5
CARBURETION	(Refer to G16A/E Service Manual Supplement)	
		CARB 6
ELECTRICAL	(Refer to G16A/E Service Manual Supplement)	
		ELEC 7
TROUBLESHOOTING	(Refer to G14A, G14E Service Manual)	?
		TRBL SHTG 8
SPECIFICATIONS		
		SPEC 9

TABLE OF CONTENTS

**CHAPTER 2 – PERIODIC INSPECTION
AND ADJUSTMENT
MAINTENANCE CHART 2-1**

**CHAPTER 9 – SPECIFICATIONS
SPECIFICATIONS 9-1
GENERAL SPECIFICATIONS 9-1
CABLE/WIRE ROUTING for G20A 9-10
EMISSION CONTROL SYSTEM 9-12
WIRING DIAGRAM 9-13**

PERIODIC INSPECTION AND ADJUSTMENT

PERIODIC MAINTENANCE

Regular maintenance is most important for best performance and safe operation.

⚠ WARNING

Be sure to turn off the main switch and apply the parking brake when you perform maintenance unless otherwise specified.

FOR G20A

C - CHECK CA - CHECK AND ADJUST R - REPLACE S - SERVICE CL - CLEAN AND LUBRICATE L - LUBRICATE

	Remarks	Pre-Operation	20 Rounds 20 hours 100 miles 160 kms (Every month)	125 rds 125 hrs 600 mls 1000 kms (Every 6 months)	250 rds 250 hrs 1200 mls 2000 kms (Every year)	500 rds 500 hrs 2500 mls 4000 kms (Every 2 years)	1000 rds 1000 hrs 5000mls 8000 kms (Every 4 years)
PRE-OPERATION CHECKS	Check engine oil	C	C	C			
	Check air cooling duct	C	C	C	C	C	C
	Check fuel lines for leakage	C	C	C	C	C	C
	Check fuel level	C	C	C	C	C	C
	Check for looseness and corrosion of battery terminals and hold downs	C	C	C	C	C	C
	Check brake pedal freeplay and adjust if necessary	C	CA	CA	CA	CA	CA
	Check steering operation	C	C	C	C	C	
	Check tire pressure, tread depth, tire surface for damage	C	CA	CA	CA	CA	CA
	Check body and chassis for damage	C	C	C	C	C	C
	Check tightness of all bolts, nuts, and screws	C	C	C	C	C	C
	Check reverse buzzer operation	C	C	C	C	C	C
EVERY MONTH	Check fuel filter for clogging		C	C	C	C	C
	Check wear of drive belt		C	C	C	C	C
	Check operation of Forward / Reverse shifting		C	C	C	C	C
	Clean / Lube pedal control area		CL				
EVERY 6 MONTHS	Wash pre-filter, check air cleaner element			S	S	S	S
	Check spark plug and plug cap condition** / Check compression			C	C	C	C
	Check shock absorbers for oil leaks and damaged springs			C	C	C	

**Related to emission control system.

PERIODIC INSPECTION AND ADJUSTMENT



C - CHECK CA - CHECK AND ADJUST R - REPLACE S - SERVICE CL - CLEAN AND LUBRICATE L - LUBRICATE

	Remarks	Pre-Operation	20 Rounds 20 hours 100 miles 160 kms (Every month)	125 rds 125 hrs 600 mls 1000 kms (Every 6 months)	250 rds 250 hrs 1200 mls 2000 kms (Every year)	500 rds 500 hrs 2500 mls 4000 kms (Every 2 years)	1000 rds 1000 hrs 5000mls 8000 kms (Every 4 years)
EVERY YEAR	Replace engine oil				R	R	R
	Adjust throttle cables,** choke cable, check carburetor throttle shaft for wear**				CA	CA	CA
	Check starter V-belt for damage and tension				C	C	C
	Check drive belt for slippage, wear or scratches				C	C	C
	Check sliding sheave and ramp shoes; Grease secondary sheave bearing.				CL	CL	CL
	Grease primary sheave				L	L	L
	Check operation of speed limiter				C	C	C
	Apply battery terminal protectant				S	S	S
	Check wiring connections and insulation				C	C	C
	Check shoe lining thickness and rear axle bearing play				C	C	C
	Check kingpin play, seal, and cap / Adjust wheel alignment				CA	CA	CA
	Check wheel nut tightness, front wheel bearing play				C	C	C
	Check gear box oil level and leakage				C	C	C
	Check operation and adjust pedal stop if necessary				CA	CA	CA
EVERY 2 YEARS	Check brushes for wear and commutator for dirt					C	S
EVERY 4 YEARS	Replace fuel filter and fuel hoses						R
	Check tightness of cylinder head / Adjust valves						CA
	Replace gear box oil						R
	Check for grease leakage; adjust gearbox if necessary						CA

**Related to emission control system.



SPECIFICATIONS

GENERAL SPECIFICATIONS

Item	Model
	G20A
Model Code: Frame Serial Number	JR8 JR8-000101 ~
Dimensions: Overall Length Overall Width Overall Height (Steering height) Height of Floor Wheelbase Tread: Front Rear Min. Ground Clearance	128.0 in (3250 mm) 47.2 in (1200 mm) 46.8 in (1190 mm) 11.8 in (300 mm) 97.8 in (2483 mm) 34.3 in (870 mm) 38.6 in (980 mm) 3.8 in (97 mm)
Weight: Dry Weight (without battery)	855 lb (388 kg)
Performance: Maximum Speed Minimum Turning Radius Seating Capacity	12 mph (19 km/h) 167.0 in (4.24 m) 4 persons



MAINTENANCE SPECIFICATIONS FOR G20A

ENGINE

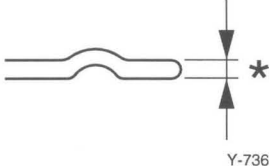
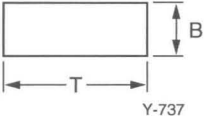
Item	G20A
Description Engine Type Number of Cylinder Displacement Bore x Stroke Compression Ratio Compression Pressure (at sea level) Starting System Ignition System Lubrication System	Forced air cooled 4-stroke OHV gasoline Single 301 cm ³ 78 x 63 mm (3.07 x 2.48 in) 8.1 : 1 Standard: 1,150 kPa (11.5 kg/cm ² , 164 psi) Minimum: 1,000 kPa (10.0 kg/cm ² , 142 psi) Starter TCI Magneto Wet sump
Cylinder Head: Combustion Chamber Volume (With spark plug) Head Gasket Thickness  Y-736	32.6 ~ 32.8 *0.20 ~ 0.23 mm (0.0078 ~ 0.009 in)
Cylinder: Material Bore Size Taper/Limit Out of Round/Limit	Cast iron sleeved aluminum (crankcase) 78 mm (3.07 in) 0.02 mm (0.0008 in)/0.15 mm (0.006 in) 0.02 mm (0.0008 in)/0.15 mm (0.006 in)
Piston: Piston-to-Cylinder Clearance < Limit > Oversize: 1 2 Piston Pin Outside Diameter Piston Pin-to-Piston Clearance < Limit >	0.03 ~ 0.05 mm (0.0012 ~ 0.0020 in) < 0.1 mm (0.004 in) > 0.25 mm (0.01 in) 0.50 mm (0.02 in) 19.995 ~ 20.000 mm (0.7872 ~ 0.7874 in) 0.004 ~ 0.020 mm (0.0002 ~ 0.0008 in) < 0.07 mm (0.003 in) >
Piston Ring: Top Ring Type Dimensions (B x T) End Gap (Installed) < Limit > Side Clearance (Installed) < Limit >  Y-737	Barrel 1.5 x 3.5 mm (0.059 x 0.137 in) 0.2 ~ 0.4 mm (0.008 ~ 0.016 in) < 1.0 mm (0.04 in) > 0.04 ~ 0.08 mm (0.0015 ~ 0.003 in) < 0.1 mm (0.004 in) >
Engine Oil: Recommended Oil Oil Change Quantity Oil Capacity	YAMALUBE 4 cycle oil or SAE10 W30 type SE, SF, or SG 1.0 U.S. qt (0.9 L, 0.19 Imp gal) 1.16 U.S. qt (1.0 L, 0.24 Imp gal)

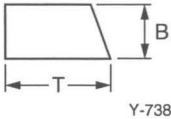
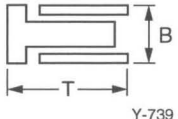
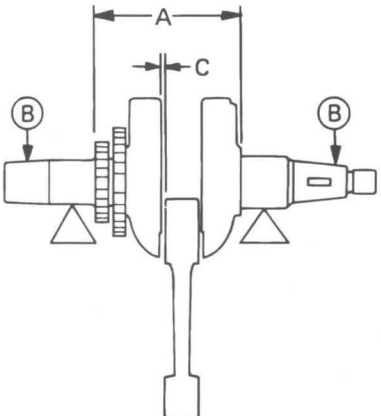
Item	G20A
<p>2nd Ring: Type Dimensions (B x T) End Gap (Installed) < Limit > Side Clearance < Limit > (Installed)</p>  <p>Oil Ring: Dimensions (B x T) End Gap (Installed)</p> 	<p>Taper 1.5 x 3.5 mm (0.059 x 0.137 in) 0.2 ~ 0.4 mm (0.008 ~ 0.016 in) < 1.0 mm (0.04 in) > 0.03 ~ 0.07 mm (0.0012 ~ 0.0028 in) < 0.1 mm (0.004 in) ></p> <p>2.5 x 2.80 mm (0.098 x 0.116 in) 0.2 ~ 0.7 mm (0.008 ~ 0.028 in)</p>
<p>Small End Bearing: Type</p>	<p>None</p>
<p>Big End Bearing: Type</p>	<p>None</p>
<p>Crankshaft: Crankshaft Assembly Width "A" Crankshaft Deflection "B" Connecting Rod Big End Side Clearance "C"</p>  <p>Crank Pin Outside Diameter Crank Pin Type Crank Oil Seal Type (Both) x Q'ty</p>	<p>104.0 ~ 105.4 mm (4.094 ~ 4.149 in) 0.05 mm (0.0020 in) 0.2 ~ 0.65 mm (0.008 ~ 0.025 in)</p> <p>35.97 ~ 35.98 mm (1.416 ~ 1.417 in) Solid crankshaft SD 35 50 8 x 2 pc</p>
<p>Camshaft: Drive Method Cam Cap Inside Diameter Camshaft Outside Diameter Shaft-to-Cap Clearance < Limit ></p>	<p>Gear drive 16.00 ~ 16.05 mm (0.630 ~ 0.632 in) 15.90 ~ 15.97 mm (0.626 ~ 0.628 in) 0.03 ~ 0.05 mm (0.0011 ~ 0.0020 in)/ < 0.15 mm (0.0059 in) ></p>

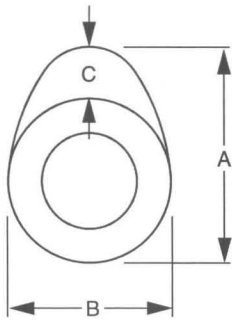
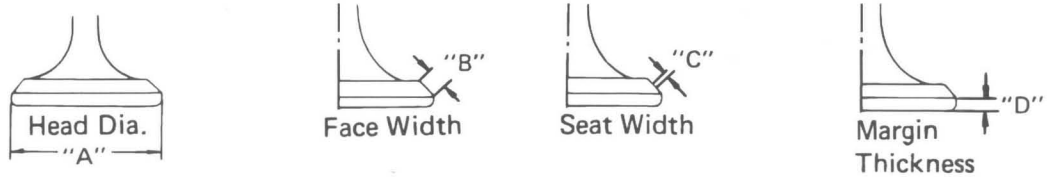
Item	G20A
<p>Cam Dimensions:</p> <p>Intake "A" "B" "C"</p> <p>Exhaust "A" "B" "C"</p>  <p style="text-align: right;">Y-741</p>	<p>32.495 ~ 32.595 mm (1.279 ~ 1.283 in) 26.029 ~ 26.129 mm (1.024 ~ 1.028 in) 6.495 ~ 6.595 mm (0.255 ~ 0.259 in)</p> <p>32.495 ~ 32.595 mm (1.279 ~ 1.283 in) 26.029 ~ 26.129 mm (1.024 ~ 1.028 in) 6.495 ~ 6.595 mm (0.255 ~ 0.259 in)</p>
<p>Rocker Arm/Rocker Arm Shaft:</p> <p>Arm Inside Diameter</p> <p>Shaft Outside Diameter</p> <p>Arm-to-Shaft Clearance</p>	<p>12.00 ~ 12.02 mm (0.472 ~ 0.473 in) 11.90 ~ 11.99 mm (0.469 ~ 0.472 in) 0.01 ~ 0.07 mm (0.0004 ~ 0.0028 in)</p>
<p>Valve, Valve Seat, Valve Guide:</p> <p>Valve Clearance (Cold) IN. EX.</p> <p>Valve Dimensions:</p>  <p style="text-align: right;">Y-742</p> <p>"A" Head Diameter IN. EX.</p> <p>"B" Face Width IN. EX.</p> <p>"C" Seat Limit Width IN. EX.</p> <p>"D" Margin Thickness Limit IN. EX.</p>	<p>0.1 mm (0.004 in) 0.1 mm (0.004 in)</p> <p>0.1 mm (0.004 in) 27 mm (1.062 in) 2.6 mm (0.102 in) 1.6 mm (0.088 in) 1.0 mm (0.0393 in) 1.0 mm (0.0393 in) 1.2 mm (0.047 in) 1.0 mm (0.0393 in)</p>
<p>Valve Spring Free Length < Limit ></p> <p>Spring Tilt</p> <p>Spring Force IN. EX.</p>	<p>36.2 mm < 35.0 mm > 2.5° or 1.6 mm 7.0 kg 9.0 kg</p>
<p>Throttle Cable Freeplay:</p> <p>Cable 1</p> <p>Cable 2</p> <p>Choke Cable Freeplay</p>	<p>0.2 ~ 0.5 mm (0.008 ~ 0.020 in) 0.5 mm (0.020 in) 1.0 mm (0.040 in) ></p>



Item	G20A
Carburetor: Model/Maker I.D. Mark Venturi Diameter (Ven. T.) Main Jet (M.J.) Main Air Jet (M.A.J.) Pilot Jet (P.J.) Pilot Air Jet (P.A.J.) Throttle Valve (Th.V.) Valve Seat (V.S.) By-pass (1) (B.P. 1) By-pass (2) (B.P. 2) By-pass (3) (B.P. 3) Pilot Outlet (P.O.) Pilot Screw (P.S.) Float Height (F.H.)	BV26-18-47/MIKUNI JN6-01 ø18 #86.3 ø1.6 #61.3 ø0.9 #150 ø1.2 ø0.7 ø0.7 ø1.0 ø1.0 1-1/2 turn out 16.5 ~ 17.5 mm (0.65 ~ 0.69 in)
Fuel Pump: Manufacturer/Type	MIKUNI/DF-52-205 (Diaphragm)
Fuel Tank: Recommended Fuel Fuel Rating P.O.N (#1) Fuel Tank Capacity Fuel Tank Material/Color	Unleaded regular gasoline MIN. 87 octane 23.0 L (20.2 Imp qt, 6.1 US gal) Polyethylene/Natural

TRANSMISSION

Item	G20A
Transmission: Type Primary Reduction Ratio Primary Spring: Secondary Spring: Outside Diameter x Wire Diameter No. of Turns/Free Length Twist Angle (Preload setting) Torque Cam Angle Sheave Center to Center Distance Sheave Off-Set V-belt Width and Outer Line Length V-belt Wear Limit	V-belt automatic centrifugal engagement 3.1 : 1 ~ 0.8 : 1 None 59 x 4.5 mm (2.32 x 0.18 in) 7.25/100.5±1.5 mm (3.95±0.059 in) 30° (B-3) 37.5° 270.5 mm 24.3 mm 31 x 1,010 mm (1.22 x 39.76 in) 27 mm (1.06 in)

MAINTENANCE SPECIFICATIONS FOR G20A



Item	G20A
Differential/Reduction Gear: Secondary Reduction System Secondary Reduction Ratio: Forward Reverse Differential Type Lubricant/Capacity	Helical gear 11.34 : 1 15.25 : 1 Bevel gear SAE 90 gear oil/420 cc (0.09 Imp qt, 0.44 US qt)
Governor: Type Adjustment Factory Speed Setting	Oil bath flyweight Screw with lock nut 19 km/h (12 mph)

ELECTRICAL

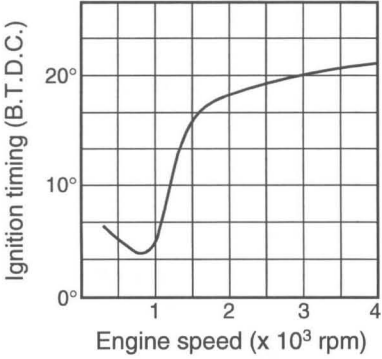
Item	G20A
Voltage:	12V Negative ground
Ignition System: Type Model/Manufacturer Dynamic Timing	T.C.I. JR8/YAMAHA 23° B.T.D.C. at 3,000 r/min
Ignition Advance Curve: <div style="text-align: center;">  <p>Y-780</p> </div>	
Ignition: Primary Winding Resistance Secondary Winding Resistance	0.9 ~ 1.5Ω ± 20% at 20°C (68°F) (Coil base to terminal) 10.5 ~ 12.9 kΩ ± 20% at 20°C (68°F) (High tension cord to terminal)

TIGHTENING TORQUE

ENGINE (FOR G20A)

Part to be tightened	Part name	Thread size	Tightening torque			Remarks
			Nm	m·kg	ft·lb	
Spark Plug		M14 x P1.25	20	2.0	14	
Air Shroud	Bolt	M6 x P1.0	8	0.8	5.8	
Cylinder Head	Bolt	M10 x P1.25	50	5.0	36	
Cylinder Head Cover	Bolt	M6 x P1.0	11	1.1	8	
Valve Adjuster Locknut	Nut	M5 x P0.5	7	0.7	5.1	
Connecting Rod Cap	Nut	M8 x P1.25	20	2.0	14	With oil splasher
Cylinder x Exhaust Pipe	Nut	M8 x P1.25	16	1.6	12	
Exhaust Pipe x Bracket	Bolt	M8 x P1.25	16	1.6	12	
Exhaust Bracket x Rear Arm	Bolt	M8 x P1.25	16	1.6	12	
Carburetor x Joint	Nut	M6 x P1.0	6.5	0.65	5	
Flywheel	Nut	M18 x P1.5	120	12.0	87	
Crankcase x Engine Bracket	Bolt	M10 x P1.25	35	3.5	25	
Engine Bracket x Rear Arm	Nut	M8 x P1.25	26	2.6	19	
Crankcase Cover, 8 mm	Bolt	M8 x P1.25	26	2.6	19	
Crankcase Cover, 10 mm	Bolt	M10 x P1.25	38	3.8	27	
Crankcase Drain Plug	Bolt	M12 x P1.5	20	2.0	14	

[Cylinder Head Tightening Sequence]

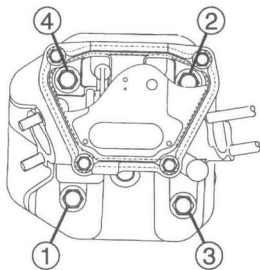

Y-726

[Crankcase Cover Tightening Sequence]

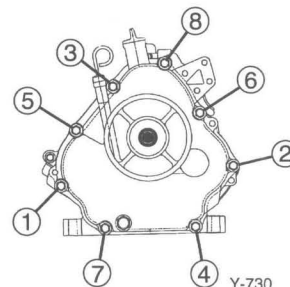

Y-730



POWER TRAIN

Part to be tightened	Part name	Thread size	Tightening torque			Remarks
			Nm	m·kg	ft·lb	
For G20A						
Primary Sheave x Engine	Bolt	1/2-20UNF-2A	75	7.5	54	
Secondary Sheave x Input Shaft	Castle nut	M12 x P1.25	65	6.5	47	
Transmission Case x Rear Arm	Bolt	M8 x P1.25	23	2.3	17	
Rear Axle Housing x Rear Arm	Bolt	M10 x P1.25	64	6.4	46	
Rear Arm Connecting Rod	Nut	M12 x P1.50	90	9.0	65	
Transmission Cover 1 and	Bolt	5/16-18UNF-2B	20	2.0	14	First
Transmission Cover 2			25	2.5	18	Final
Differential Case x Ring Gear	Bolt	M8 x P1.25	55	5.5	40	



CABLE/WIRE ROUTING FOR G20A

- | | |
|---------------------|-----------------------------------|
| ① Choke cable | ⑥ Brake cables |
| ② Main switch wire | ⑦ Negative lead |
| ③ Pilot lamp wire | ⑧ Positive lead |
| ④ Stop switch wire | ⑨ Lead wires to starter generator |
| ⑤ Accelerator cable | ⑩ T.C.I. unit wire lead |

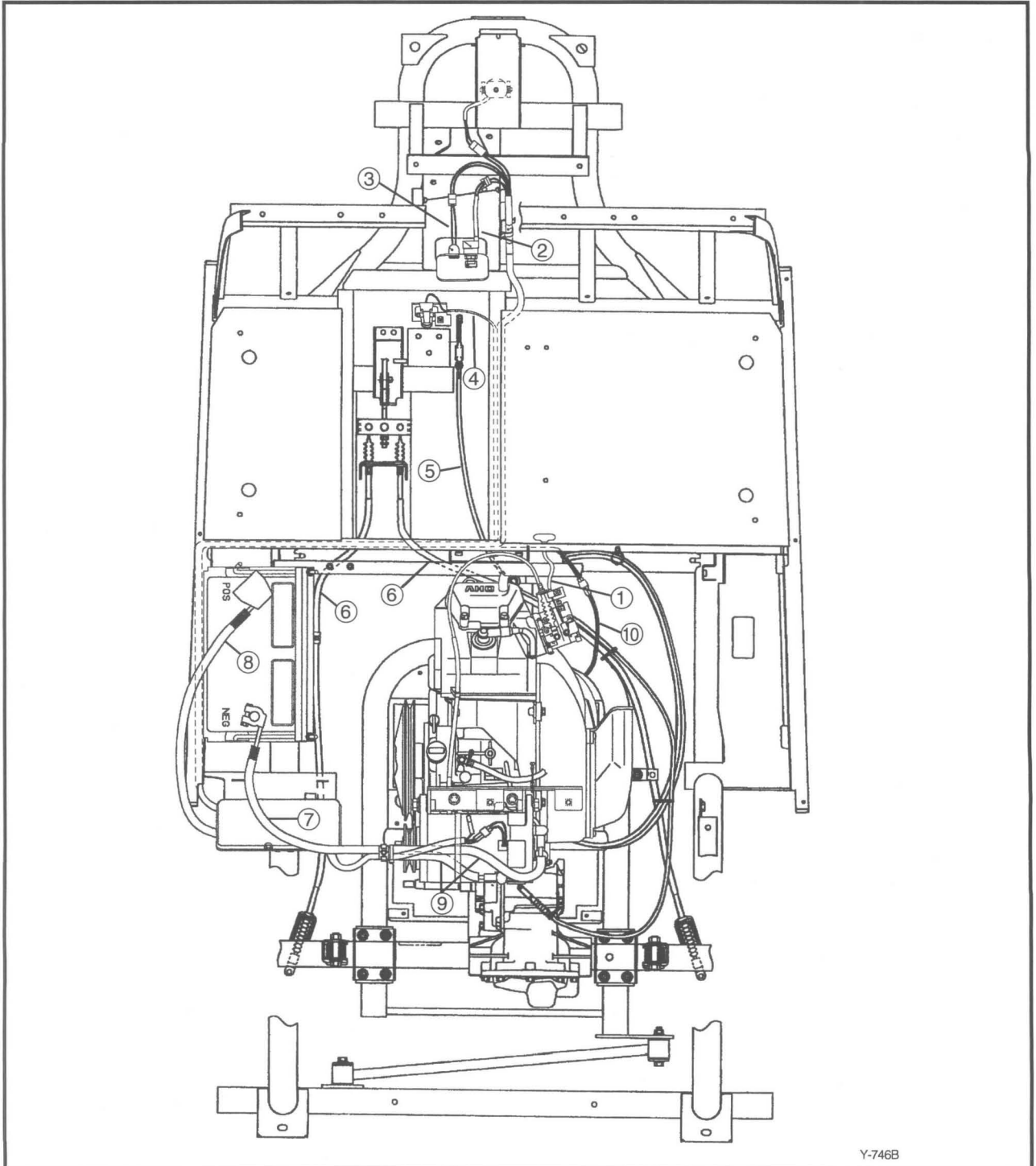

Y-746B

- ① Back-up buzzer switch lead
- ② Solenoid relay
- ③ Shift cables
- ④ Voltage regulator
- ⑤ Starter generator leads
- ⑥ Fuse
- ⑦ Stop relay
- ⑧ Fuel hose to fuel tank
- ⑨ Fuel hose to carburetor
- ⑩ Pulse hose to crankcase
- ⑪ T.C.I. wire lead
- ⑫ Oil warning switch lead

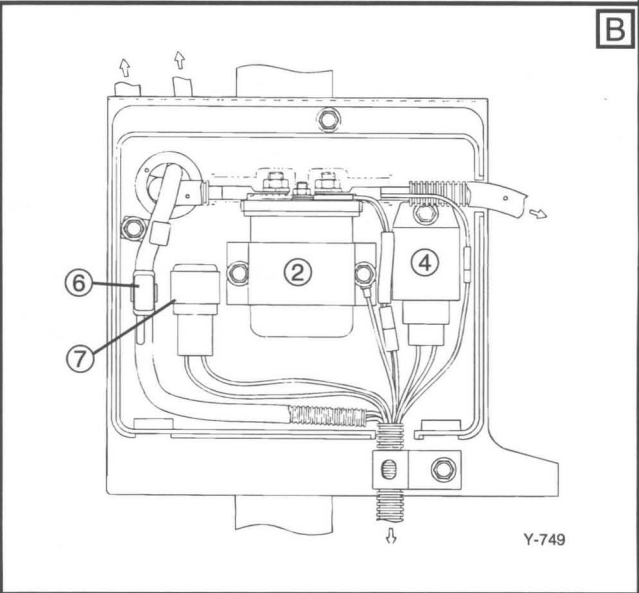
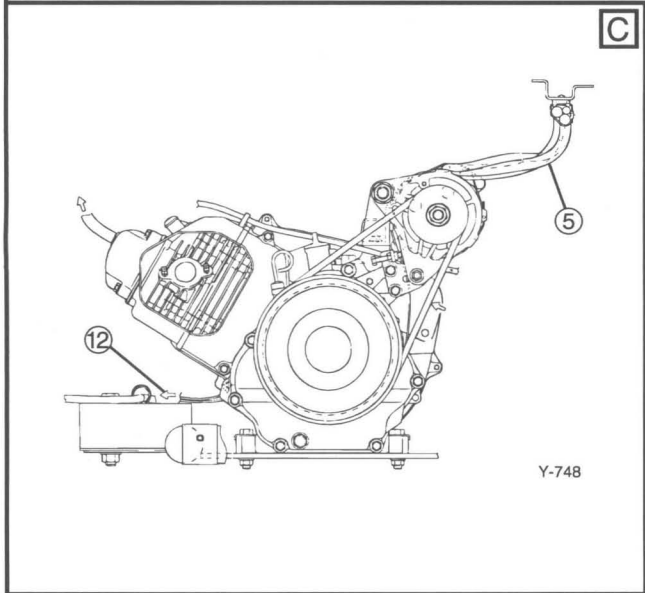
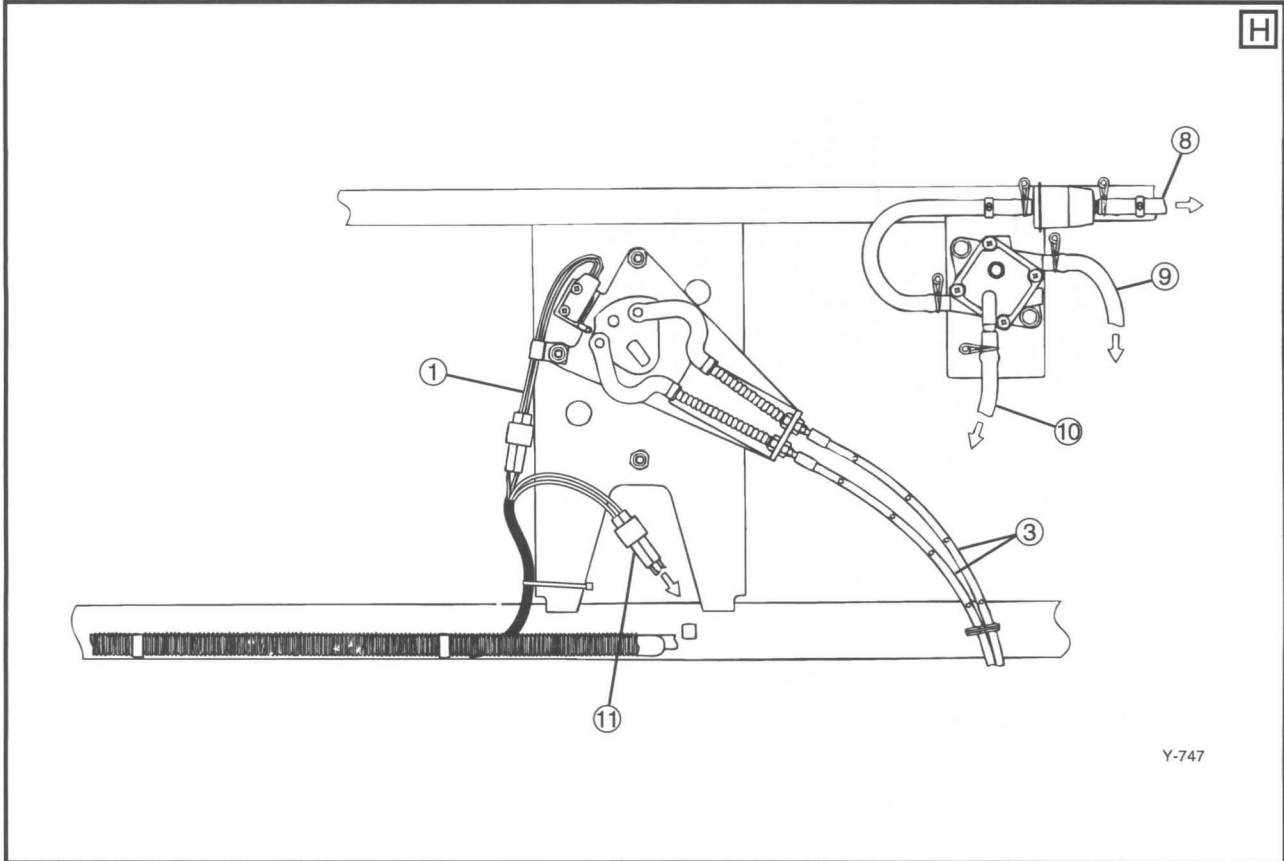

**EMISSION CONTROL SYSTEM COMPONENTS**

- ① Air cleaner
- ② Crankcase breather hose
- ③ Engine
- ④ Carburetor
- ⑤ TCI Magneto
- ⑥ Exhaust

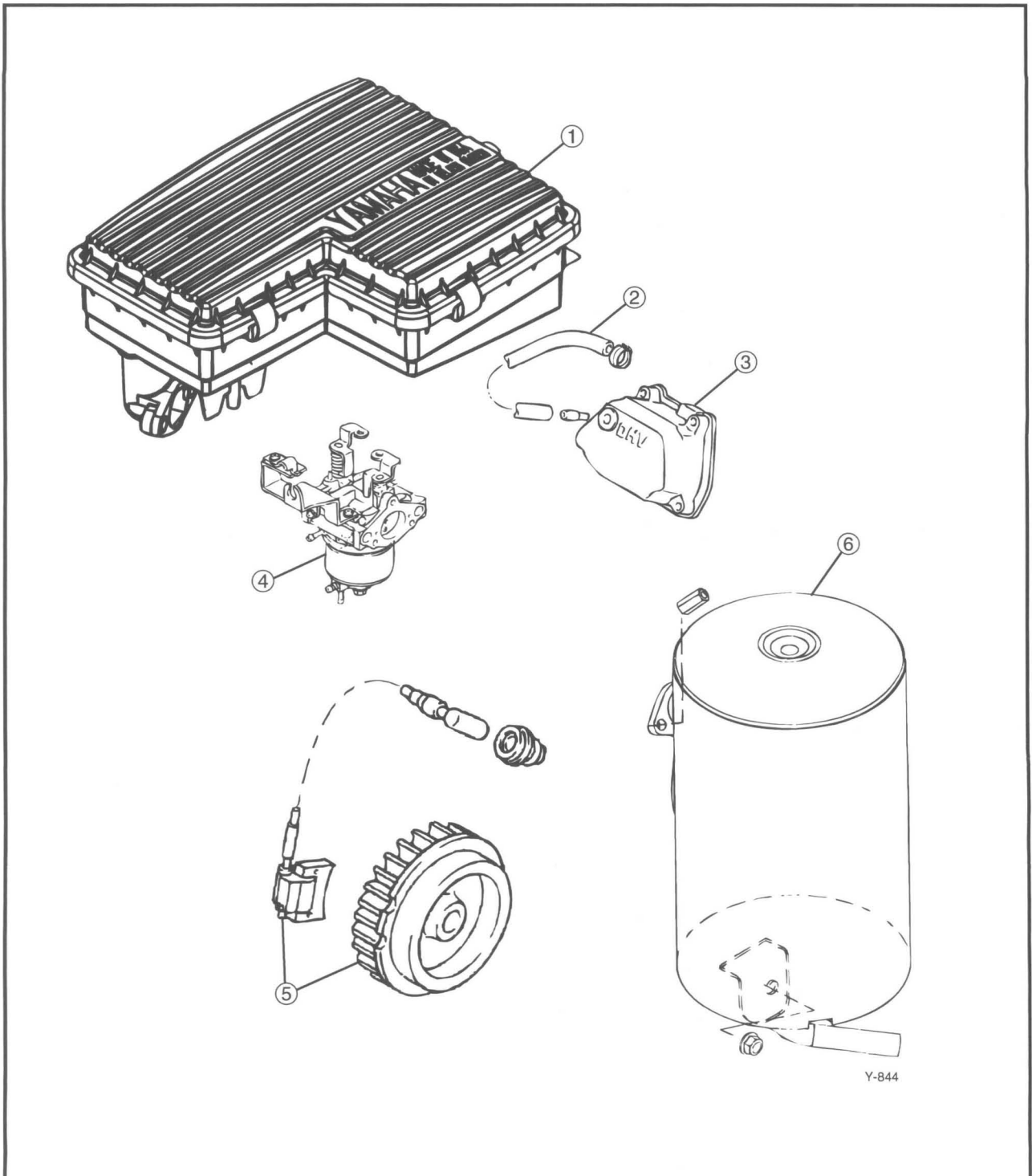

Y-844

WIRING DIAGRAM
FOR G20A

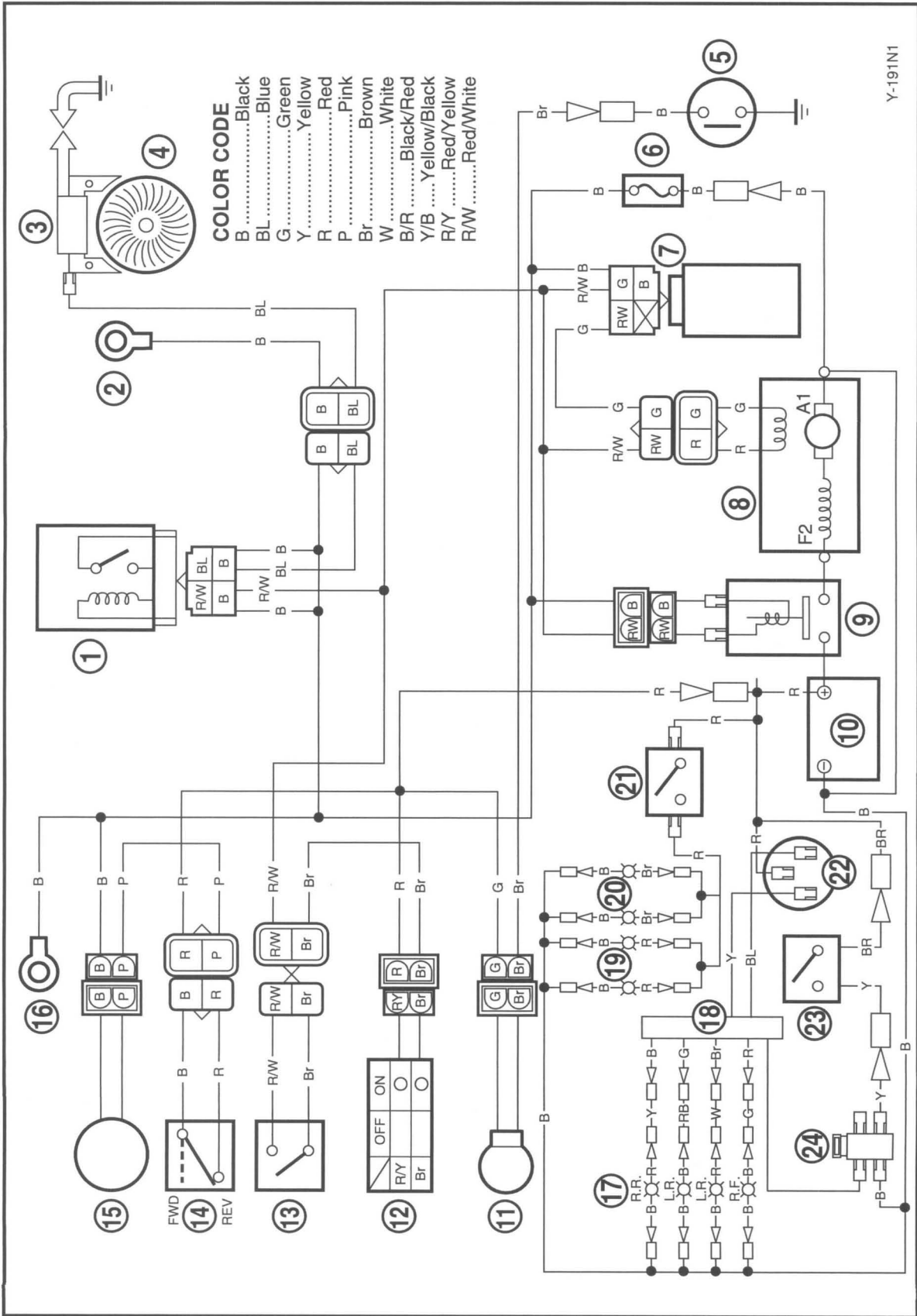

- ① Engine stop relay
- ② Engine ground
- ③ Pickup
- ④ Rotor
- ⑤ Oil level gauge
- ⑥ Blade fuse (10A)
- ⑦ Voltage regulator
- ⑧ Starter generator
- ⑨ Relay
- ⑩ Battery
- ⑪ Pilot lamp (12V, 3.4W)
- ⑫ Main switch
- ⑬ Accelerator stop switch
- ⑭ Back switch
- ⑮ Buzzer
- ⑯ Body ground
- ⑰ Signal lights
- ⑱ Turn signal lever
- ⑲ Head lights
- ⑳ Tail lights
- ㉑ Head light switch
- ㉒ Flasher unit
- ㉓ Brake light switch
- ㉔ Brake light sensor