

YAMAHA

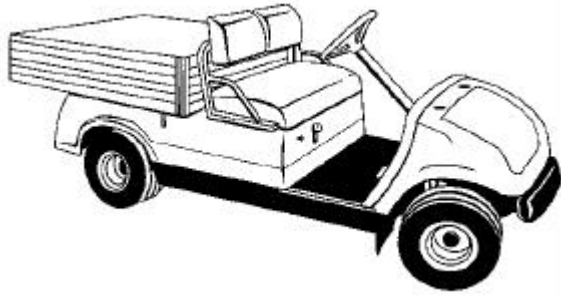

PARTS CATALOG

1997 G11AR

1998 G11AS

1999 G11AT

2000 G11AU

2001 G11AW

(JR31) U.S.A., CANADA, EUROPE, OTHERS

MARCH 2000

10JR3-100E4

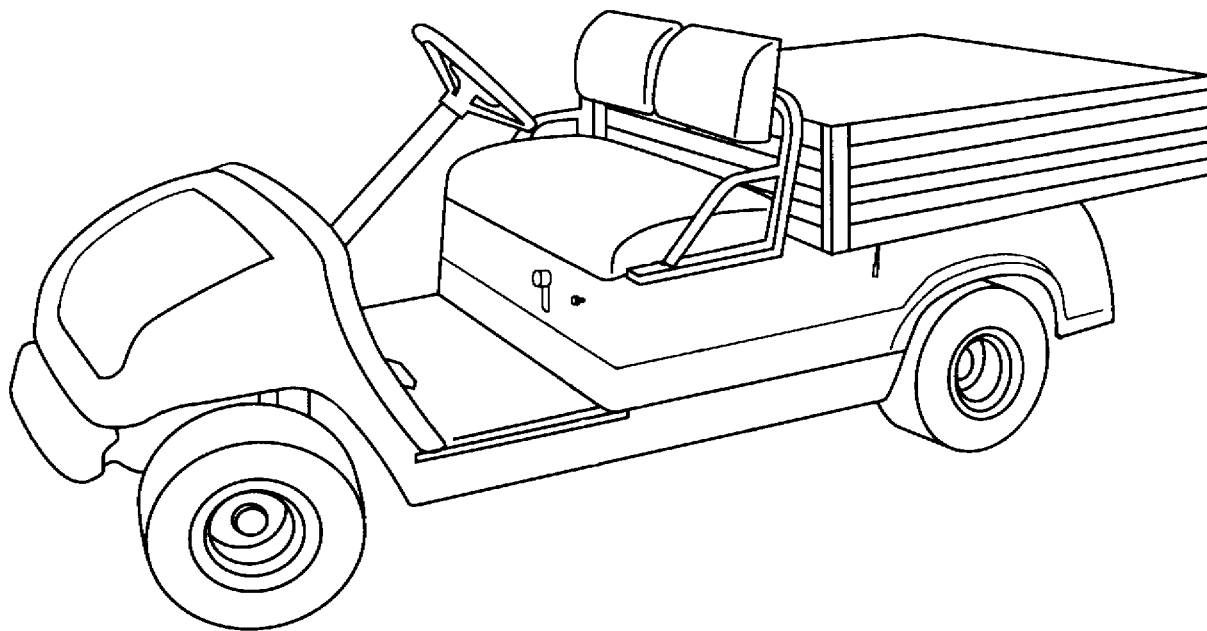

FOREWARD

This Parts Catalogue is related to the parts for the model(s) shown in the frame below. When you are ordering replacement parts, please refer to this Parts Catalogue and quote both part numbers and part names correctly.

G11A (JR31)

1. Modifications or additions which have been made after issue of the Parts Catalogue will be announced in the Yamaha Parts News. it is advisable that you make necessary corrections to the Parts Catalogue according to the Yamaha Parts News.

2. Abbreviations
The following abbreviations are used in this Parts Catalogue.

- "UR" Use specified part number.
- "UN" Use as many as needed.
- "AP" Alternate parts.
- "LM" Local Made (Parts need to be ordered locally)
- "F#" Frame Number (Applicable machine number)

3. Parts, which are to be supplied in an assembly, are listed with a dot (.) in front of the part name as shown below.

EXAMPLE
 CARBURETOR ASSY
 .JET, PILOT
 .NOZZLE, MAIN

4. Number of component for assembly
 The numeral appearing to the right of each component part indicates the quantity of parts for each assembly unit.

EXAMPLE

PART NO.	DESCRIPTION	Q'TY	REMARKS
2F5-83310-60	FRONT FLASHER LIGHT ASSY	2	
115-83311-60	.BULB (6V-18W)	1	

5. Applicable colors of graphics are represented in the "REMARKS" as shown below.

PART NO.	DESCRIPTION	Q'TY	REMARKS
2N4-24110-00-X5	FUEL TANK COMP.	1	MAXIM RED
3J1-24240-10	.GRAPHIC, FUEL TANK	1	for MXR

6. Applicable Serial No. and Color Code

① Frame Serial No. JR3-000101 ~
② Engine Serial No. JR3-000101 ~

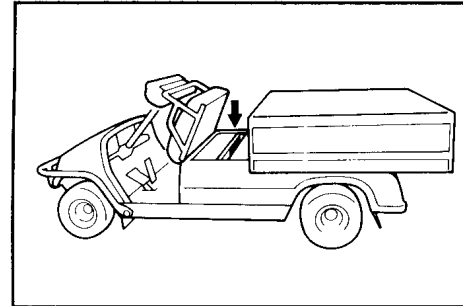

① Frame Serial No. JR3-300101 ~
② Engine Serial No. JR3-300101 ~

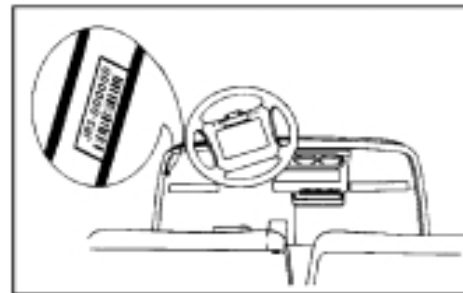

7. Note that the illustrations are for reference in finding parts numbers, not to be used for assembling. When assembling, please use the applicable service manual.

8. The asterisk (*) before a reference number indicates modification items after the first edition.

FIG. 1 ENGINE ASSEMBLY

REF NO.	PART NUMBER	DESCRIPTION	QTY	REMARKS
1	JR3-19001-00-00	ENGINE ASSEMBLY	1	

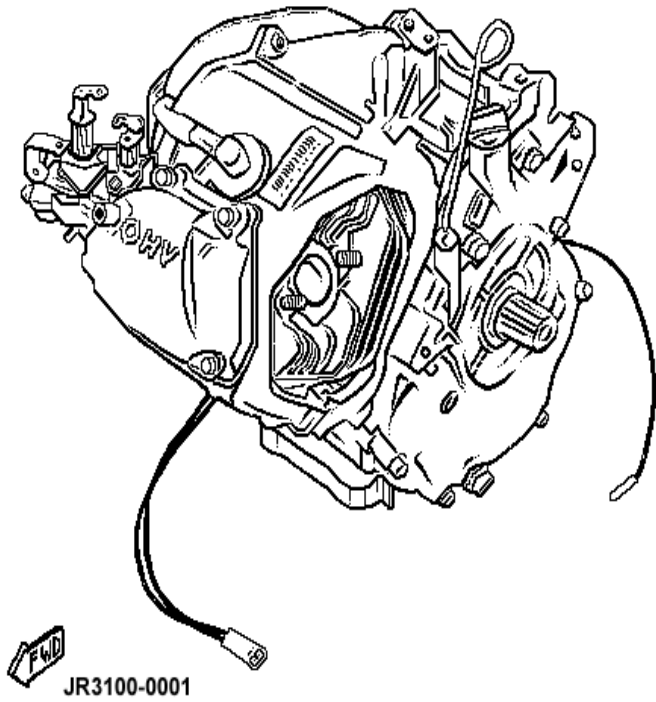

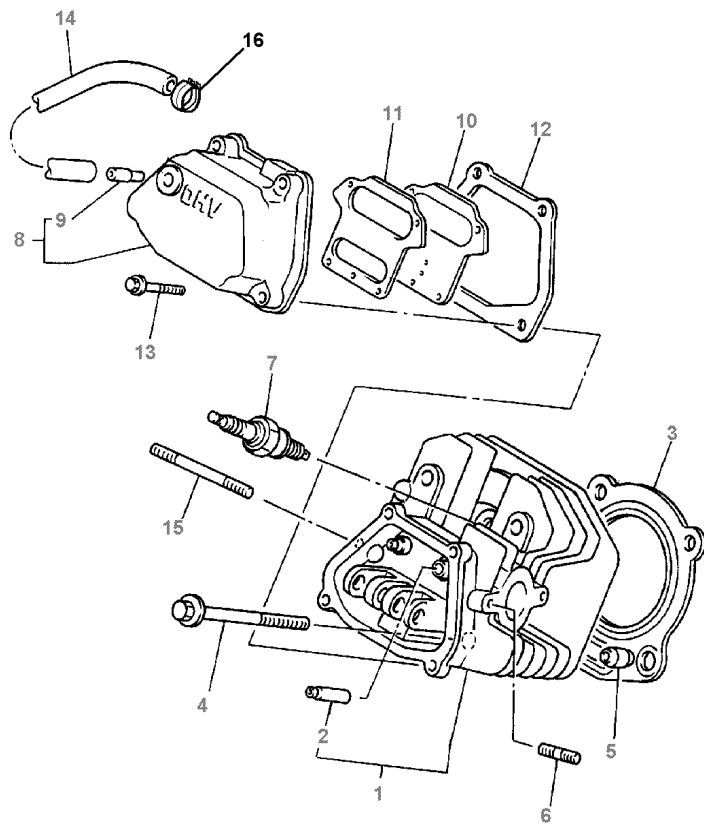

FIG. 2 CYLINDER HEAD

REF NO.	PART NUMBER	DESCRIPTION	QTY	REMARKS
1	JN6-11102-00-00	HEAD, CYLINDER	1	
2	JN6-11133-10-00	.GUIDE, VALVE	2	
3	JN6-11181-00-00	GASKET, CYLINDER HEAD	1	
4	95817-10070-00	BOLT, FLANGE	4	
5	99530-14016-00	PIN, DOWEL A	2	
6	95617-08618-00	BOLT, STUD	2	
7	NGK-BPR2E-S0-00	PLUG, SPARK	1	STD, U.S.
	94702-00348	PLUG, SPARK	1	STD, EUROPE
	NGK-BPR4E-S0-00	PLUG, SPARK	1	AP, U.S.
	94702-00343	PLUG, SPARK	1	AP, EUROPE
8	JN6-11191-01-00	COVER, CYLINDER	1	
9	JN6-11116-00-00	.JOINT, BREATHER	1	
10	JN6-11168-00-00	COVER, BREATHER	1	
11	JN6-11169-00-00	GASKET, BREATHER	1	
12	JN6-11193-00-00	GASKET, HEAD COVER	1	
13	95817-06030-00	BOLT, FLANGE	4	
14	JN6-E1166-00-00	PIPE, BREATHER	1	
15	95617-08710-00	BOLT, STUD	2	
16	90467-13847-00	CLAMP	2	



JN7010-6011

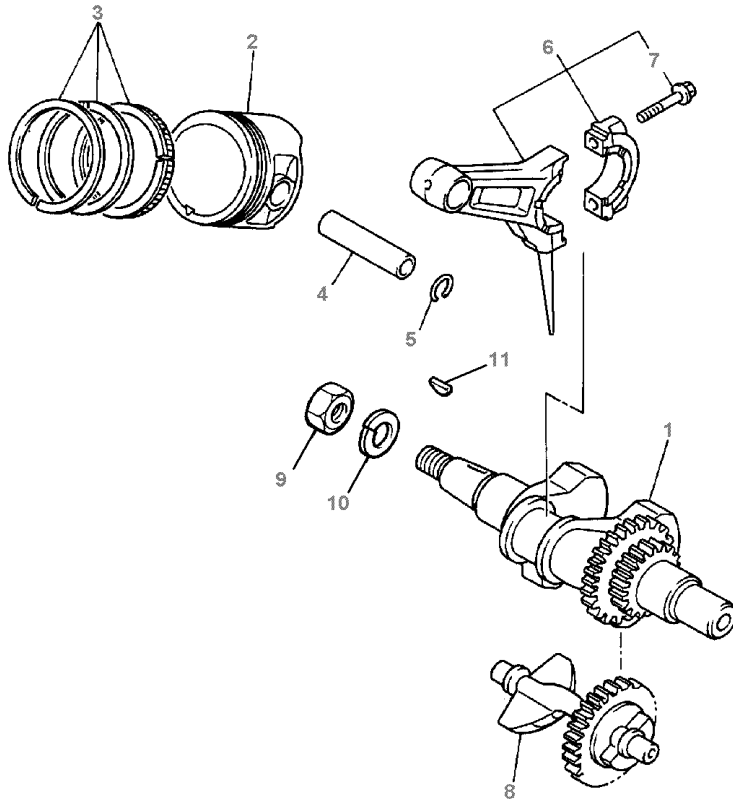
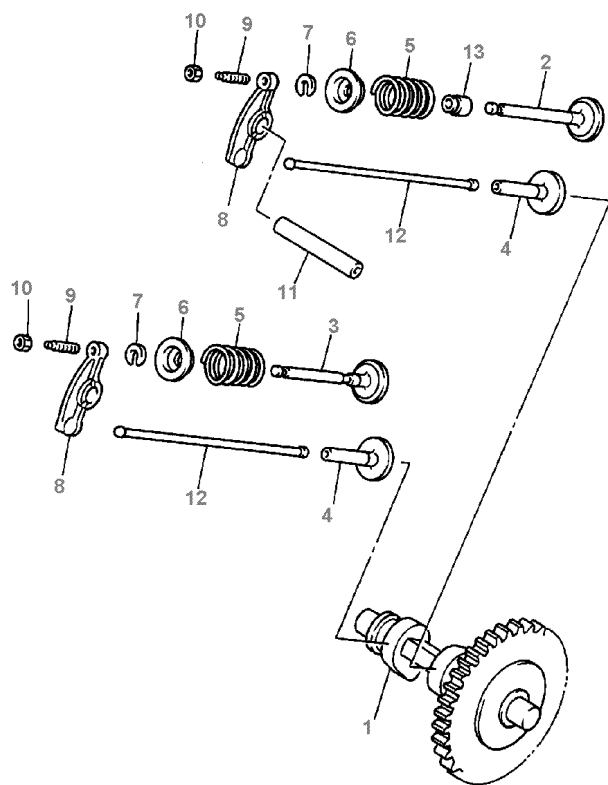

FIG. 3 CRANKSHAFT / PISTON

REF NO.	PART NUMBER	DESCRIPTION	QTY	REMARKS
1	JN6-11400-00-00	CRANK ASSY.	1	
2	JN6-11631-00-A0	PISTON, (STD)	1	STD
	JN6-11635-00-00	PISTON, (0.25mm O/S)	1	AP
	JN6-11636-00-00	PISTON (0.50mm O/S)	1	AP
3	JN6-11610-00-00	PISTON RING SET, STD.	1	STD
	JN6-11610-10-00	PISTON RING SET, (0.25mm O/S)	1	AP
	JN6-11610-20-00	PISTON RING SET, (0.50mm O/S)	1	AP
4	447-11633-00-00	PIN, PISTON	1	
5	93450-21053-00	CIRCLIP	2	
6	JN6-11650-00-00	CONNECTING ROD ASSY	1	
7	JN6-11654-00-00	.BOLT, CONNECTING ROD	2	
8	JN6-11454-00-00	WEIGHT, 1	1	
9	95317-18600-00	NUT, HEX.	1	
10	90201-18620-00	WASHER, PLAIN	1	
11	90280-04052-00	KEY, WOODRUFF	1	

FIG. 4 CAMSHAFT / VALVE



REF NO.	PART NUMBER	DESCRIPTION	QTY	REMARKS
1	JN6-12171-00-00	SHAFT, CAM 1	1	
2	JN6-12111-01-00	VALVE, INTAKE	1	
3	JN6-12121-00-00	VALVE, EXHAUST	1	
4	JN6-12153-00-00	LIFTER, VALVE	2	
5	90501-264A9-00	SPRING, COMPRESSION	2	
6	J38-12117-01-00	RETAINER, VALVE SPRING	2	
7	J38-12118-00-00	LOCK, VALVE SPRING	2	
8	JN6-12151-00-00	ARM, VALVE ROCKER	2	
9	22F-12159-00-00	SCREW, VALVE	2	
10	90170-05302-00	NUT, HEX.	2	
11	J38-12156-00-00	SHAFT, ROCKER	1	
12	JN6-12154-00-00	ROD, VALVE PUSH	2	
13	5H0-12119-00-00	SEAL, VALVE STEM	1	

 JN7010-6030

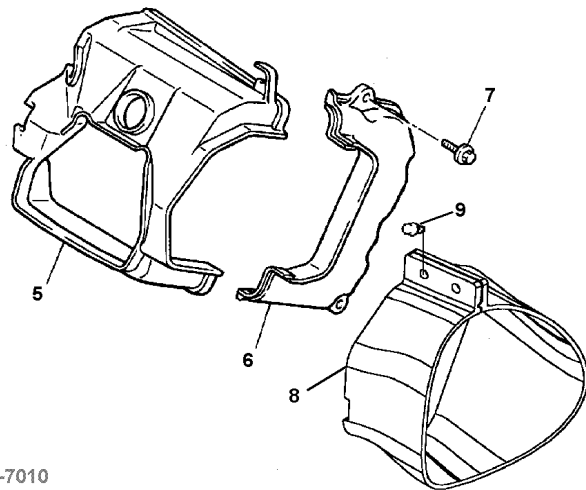
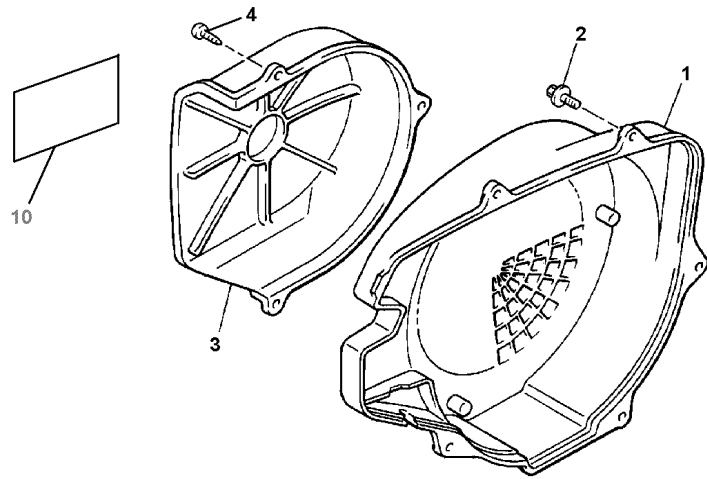

JR3100-7010

FIG. 5 AIR SHROUD / FAN

REF NO.	PART NUMBER	DESCRIPTION	QTY	REMARKS
1	JN6-12621-00-00	CASE, FAN 1	1	
2	95817-06020-00	BOLT, FLANGE	5	
3	JN6-12616-00-00	COVER, FAN CASE	1	
4	97707-60520-00	SCREW, PAN HEAD	3	
5	JN6-12651-00-00	AIR SHROUD, CYLINDER 1	1	
6	JN6-12652-00-00	AIR SHROUD, CYLINDER 2	1	
7	95817-06020-00	BOLT, FLANGE	2	
8	JN6-E2691-00-00	DUCT, 1	1	
9	90269-08813-00	RIVET	2	
10	JR3-2179V-03-00	PLATE, EPA / CALIF.	1	UR, U.S. MODEL

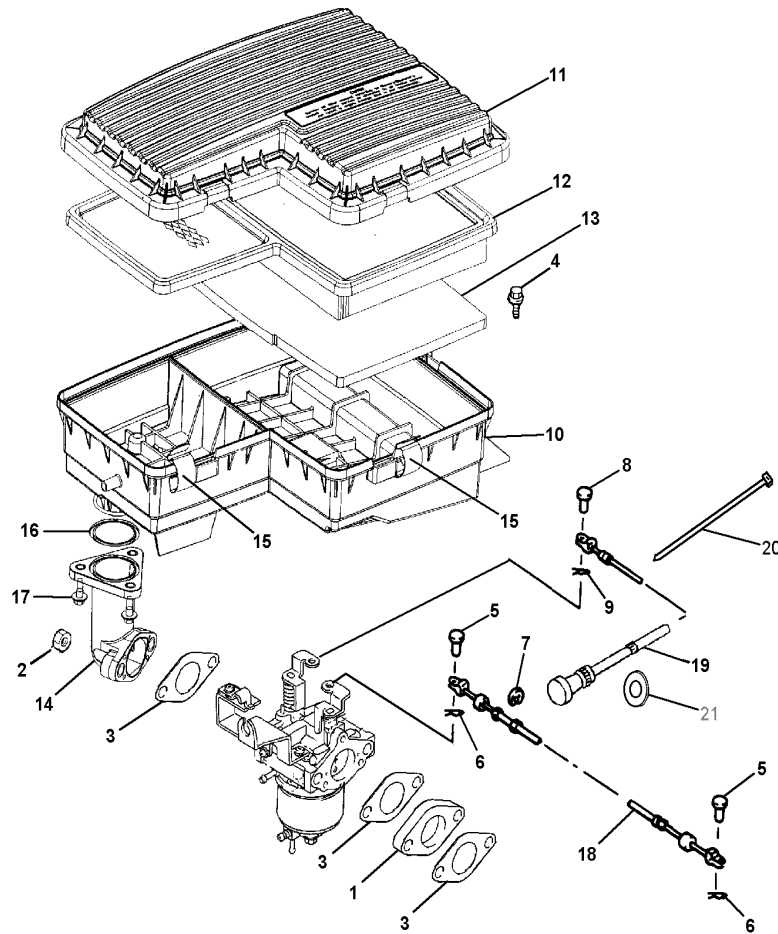

 JR3100-7110

FIG. 6 INTAKE

REF NO.	PART NUMBER	DESCRIPTION	QTY	REMARKS
1	JN6-13595-00-00	JOINT	1	
2	95707-08500-00	NUT, FLANGE	2	
3	JN6-13567-00-00	GASKET	3	
4	90119-06920-00	BOLT, HEX HEAD W/WASHER	2	
5	91790-05010-00	PIN, CYL. HEAD	2	
6	90468-10050-00	CLIP	2	
7	99080-07600-00	CIRCLIP (E)	1	
8	91790-05010-00	PIN, CYL. HEAD	1	
9	90468-10050-00	CLIP	1	
10	JN6-E4411-02-00	CASE, AIR FILTER	1	
11	JN6-E4412-01-00	CAP, CASE 1	1	
12	JN6-E4450-01-00	ELEMENT ASSY.	1	
13	JN6-E445E-00-00	FILTER, 1	1	
14	JN6-E3586-01-00	JOINT, CARBURETOR	1	
15	JN6-E4424-00-00	CLIP, CAP FIT	5	
16	93210-398D6-00	O-RING	1	
17	90105-06862-00	BOLT, FLANGE	3	
18	JN6-F6312-01-00	WIRE, THROTTLE	1	
19	JN6-F6331-00-00	WIRE, STARTER	1	
20	90464-31827-00	CLAMP	1	
21	90201-118N2-00	WASHER, PLAIN	1	

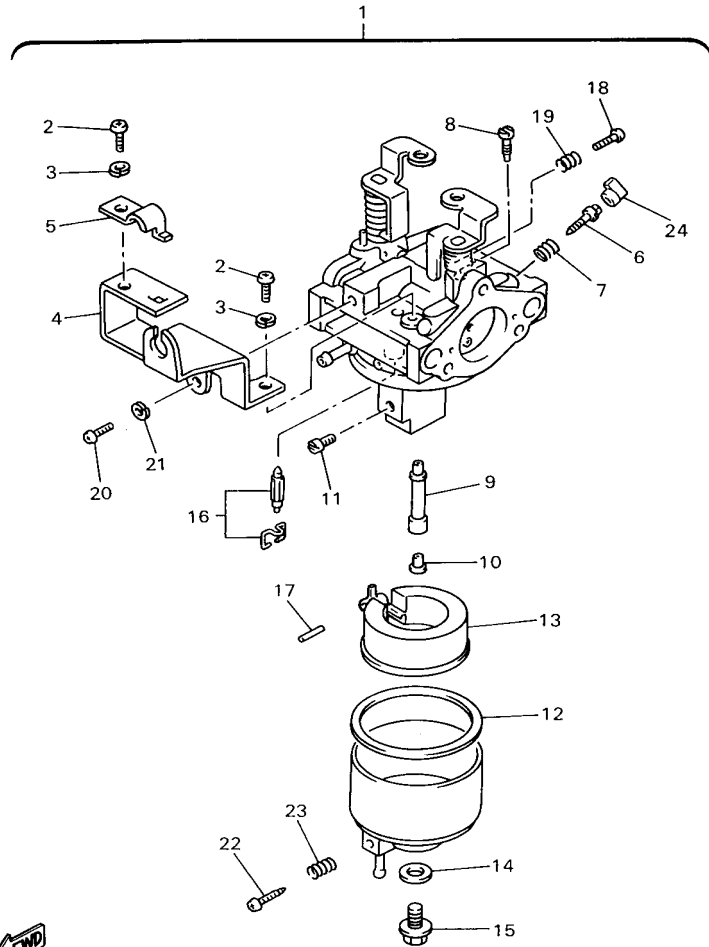

JR2010-7060

FIG. 7 CARBURETOR

REF NO.	PART NUMBER	DESCRIPTION	QTY	REMARKS
1	JN6-14101-14-00	CARBURETOR ASSY.	1	UR, F# JR3-100701~
2	98507-05100-00	.SCREW, PAN HEAD	2	
3	92990-05100-00	.WASHER	2	
4	JN6-14291-00-00	.BRACKET 1	1	
5	J10-14227-00-00	.WASHER	1	
6	7LV-14211-00-00	.SCREW, PILOT ADJUSTING	1	
7	73A-14212-00-00	.SPRING, PILOT ADJUSTING	1	
8	620-1414J-24-00	.JET, PILOT	1	(#61.3)
9	JN6-1495H-3B-00	.NOZZLE, MAIN	1	
10	73A-1414G-00-00	.PIPE, MAIN BLEED	1	
11	3G2-1423E-33-00	.JET, MAIN	1	(#83.8)
12	796-14184-00-00	.GASKET, FLOAT CHAMBER	1	
13	JN6-14185-00-00	.FLOAT	1	
14	127-14198-00-00	.GASKET	1	
15	7R1-14162-00-00	.BOLT, HOLDING	1	
16	JN5-14150-00-00	.NEEDLE ASSY	1	
17	22F-14186-00-00	.PIN, FLOAT	1	
18	1WG-14922-00-00	.SCREW, THROTTLE	1	
19	73A-14212-10-00	.SPRING	1	
20	98507-04010-00	.SCREW, PAN HEAD	1	
21	92990-05100-00	.WASHER	1	
22	7E1-14191-00-00	.PLUG, DRAIN	1	
23	73A-14212-00-00	.SPRING	1	
24	7LV-14118-00-00	.CAP	1	
	1K7-14197-01-00	.VENT HOSE	1	F# JR3-100701~

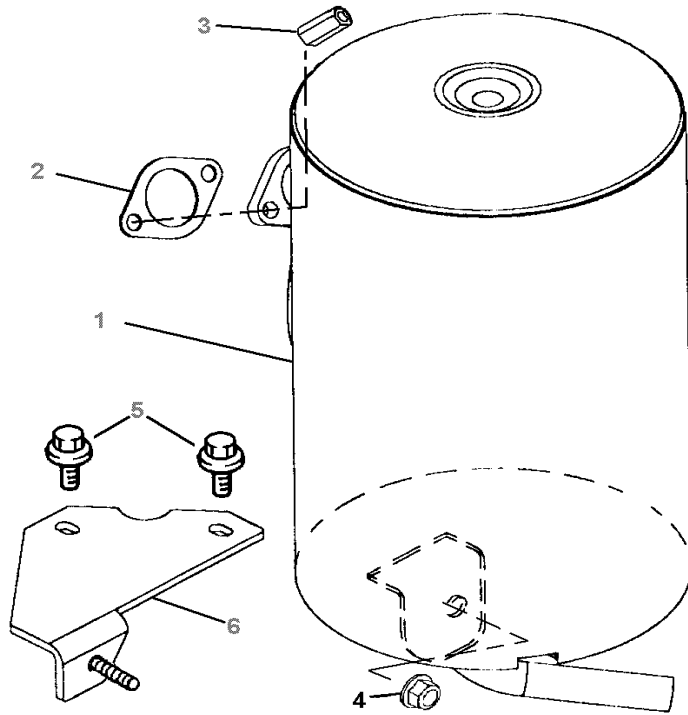

JN6100-6021

FIG. 8 EXHAUST

REF NO.	PART NUMBER	DESCRIPTION	QTY	REMARKS
1	JN6-E4710-00-00	MUFFLER ASSEMBLY	1	
2	7KY-14613-01-00	GASKET, EXHAUST 1	1	
3	90179-08879-00	NUT	2	
4	90185-08841-00	NUT, U-FLANGE	1	
5	90119-08825-00	BOLT, HEX HEAD W/WASHER	2	
6	JN6-F1435-10-00	BRACKET, MUFFLER	1	

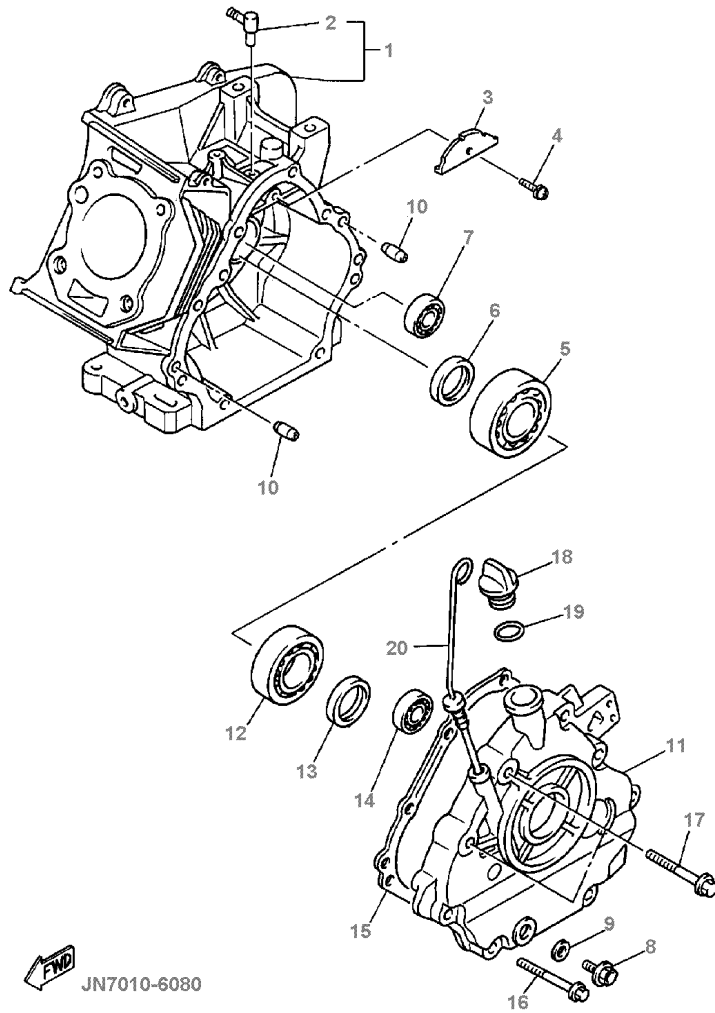
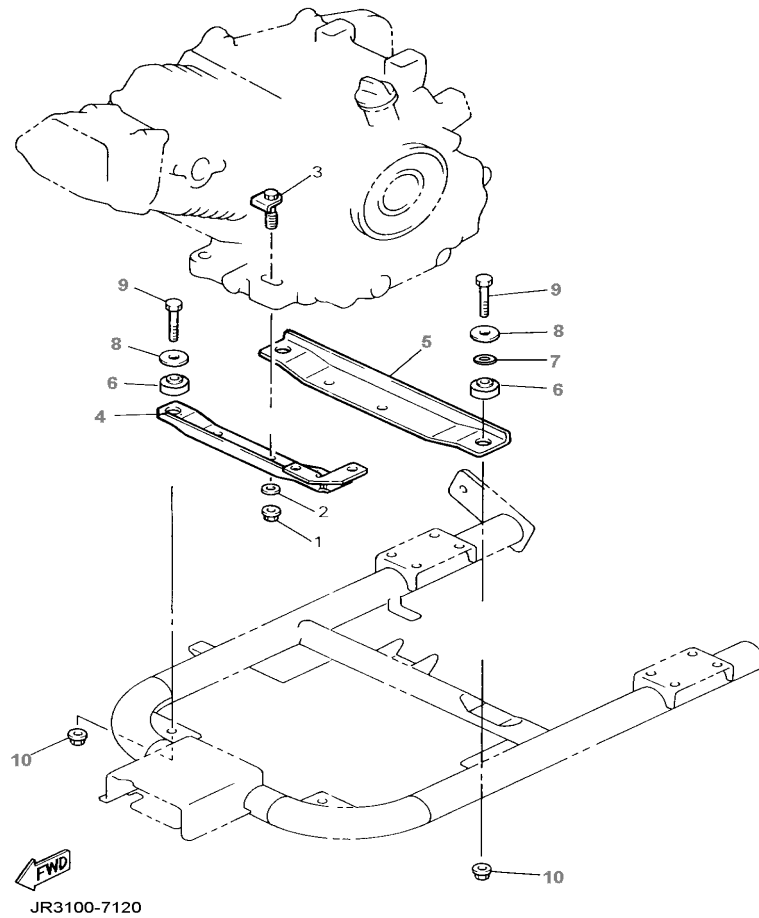

FIG. 9 CRANKCASE

REF NO.	PART NUMBER	DESCRIPTION	QTY	REMARKS
1	JN6-15100-02-00	CRANKCASE ASSY	1	
2	JN6-15155-00-00	.NOZZLE, 3	1	
3	JN6-15123-00-00	PLATE, BAFFLE	1	
4	90159-06107-00	SCREW, W/WASHER	1	
5	93306-30709-00	BEARING	1	
6	93102-35191-00	SEAL, OIL	1	
7	93306-20211-00	BEARING	1	
8	90340-12097-00	PLUG, STRAIGHT	1	
9	812-11198-00-00	GASKET	1	
10	91808-16023-00	PIN, DOWEL A	2	
11	JN6-15411-00-00	COVER, CRANKCASE	1	
12	93306-20716-00	BEARING	1	
13	93102-35191-00	SEAL, OIL	1	
14	93306-20211-00	BEARING	1	
15	JN6-15451-02-00	GASKET, CRANKCASE	1	
16	95817-08045-00	BOLT, FLANGE	6	
17	95817-10050-00	BOLT, FLANGE	2	
18	796-15363-01-00	PLUG, OIL	1	
19	93210-22344-00	O-RING	1	
20	J38-15361-00-00	GAUGE, LEVEL	1	

FIG. 10 ENGINE MOUNT



REF NO.	PART NUMBER	DESCRIPTION	QTY	REMARKS
1	95607-10200-00	NUT, U-FLANGE	4	
2	92907-10200-00	WASHER, PLAIN	4	
3	JN6-F1481-00-00	BOLT, ENGINE	4	
4	JN6-F1411-00-00	BRACKET, ENGINE 1	1	
5	JN6-F1419-02-00	BRACKET, ENGINE 2	1	
6	JR3-F1459-00-00	SPACER	4	
7	92990-82000-00	WASHER, PLAIN	2	
8	90201-088K6-00	WASHER, PLAIN	4	
9	90101-08880-00	BOLT, HEX	4	
10	90179-08885-00	NUT, U-FLANGE	4	

FIG. 11 REAR ARM / SUSPENSION

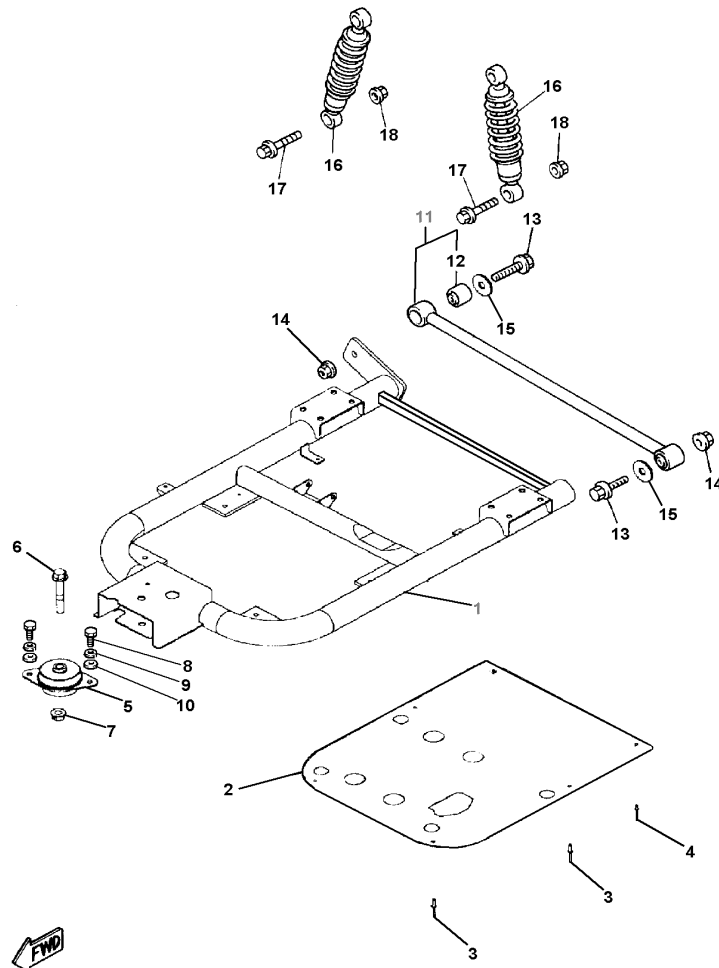

JR3100-7020

REF NO.	PART NUMBER	DESCRIPTION	QTY	REMARKS
1	JN6-F2110-01-00	REAR ARM COMP.	1	
2	JN6-F2128-01-00	COVER, 1	1	
3	90267-48850-00	RIVET, BLIND	4	
4	90267-40851-00	RIVET, BLIND	2	
5	JN6-F2123-01-00	BUSHING, 1	1	
6	90105-13864-00	BOLT, FLANGE	1	
7	90179-13878-00	NUT	1	
8	97017-10020-00	BOLT, HEX. HEAD	2	
9	92907-10100-00	WASHER, LOCK	2	
10	92907-10600-00	WASHER, PLAIN	2	
11	JN6-F217G-00-00	ROD, CONNECTING ASSY.	1	
12	JN6-F2124-00-00	.BUSHING, 2	2	
13	95817-12065-00	BOLT, FLANGE	2	
14	95617-12200-00	NUT, U-FLANGE	2	
15	90201-12426-00	WASHER, PLAIN	2	
16	JJ3-F2210-00-00	SHOCK ABSORBER	2	
17	95807-10055-00	BOLT, FLANGE	4	
18	95607-10200-00	NUT, U-FLANGE	4	

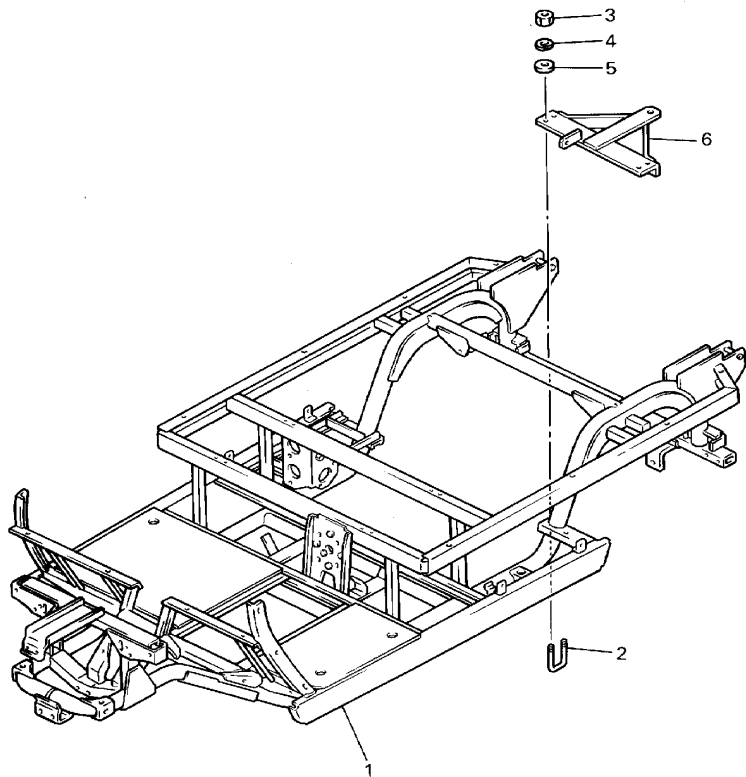

JJ3110-6110

FIG. 12 FRAME

REF NO.	PART NUMBER	DESCRIPTION	QTY	REMARKS
1	JR3-F2501-00-00	FRAME COMP.	1	
2	90109-10862-00	BOLT	2	
3	90170-10847-00	NUT, HEX	4	
4	92907-10100-00	WASHER, SPRING	4	
5	92907-10200-00	WASHER, PLAIN	4	
6	JJ3-F722B-02-00	BAR, TOW	1	

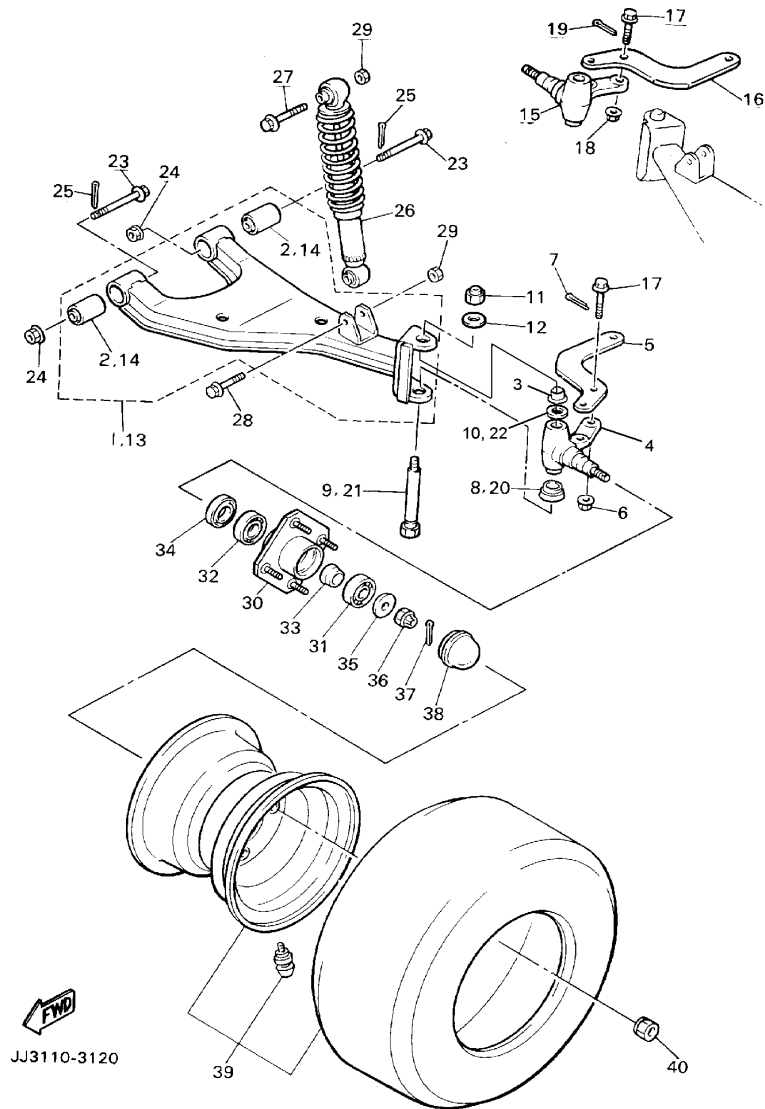
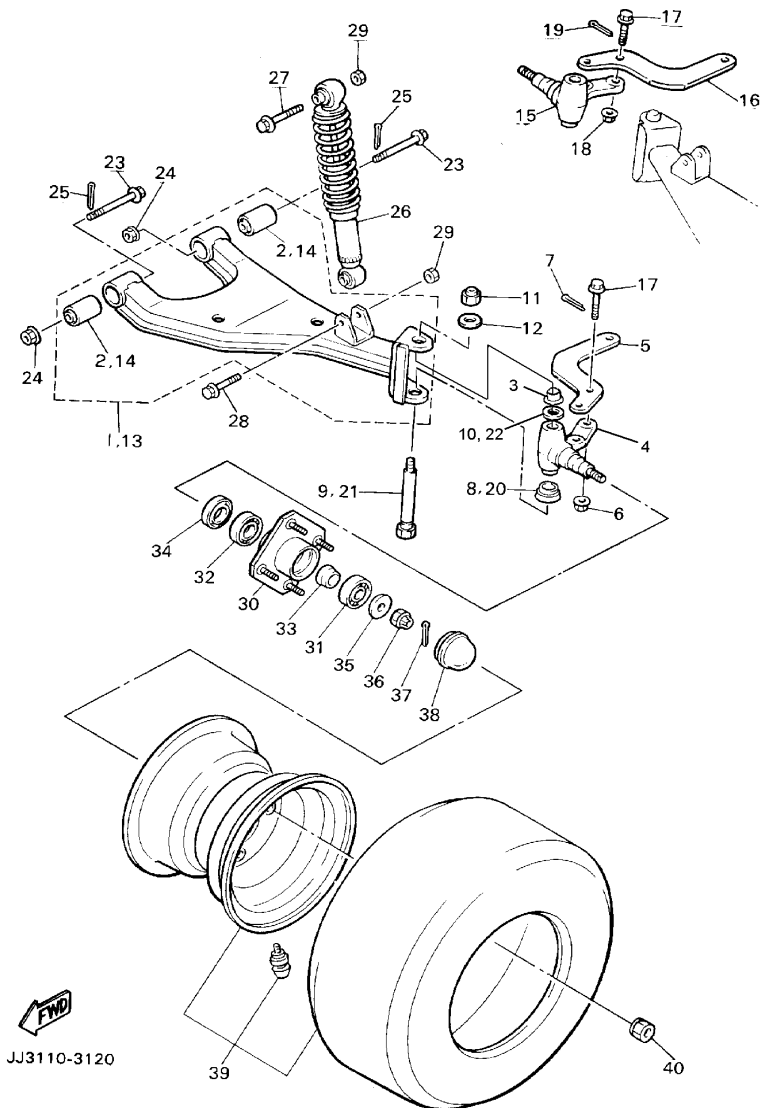

FIG. 13 FRONT SUSPENSION / WHEEL

REF NO.	PART NUMBER	DESCRIPTION	QTY	REMARKS
1	JR3-F3570-10-00	FRONT LOWER ARM, LEFT	1	
2	JN6-F3526-00-00	.BUSHING, ARM	2	
3	90384-15825-00	BUSH, BIMETAL	2	UR, F# JR3-100701~
4	JR3-F3501-00-00	KNUCKLE, STEERING LEFT	1	
5	JN3-F3512-00-00	ARM, KNUCKLE	1	
6	95617-10200-00	NUT, U-FLANGE	2	
7	91490-25020-00	PIN, SPLIT	2	
8	J38-23527-00-00	SEAL, DUST 1	1	
9	JJ3-F3516-00-00	PIN, STEERING KNUCKLE	1	
10	90201-156J2-00	WASHER, PLAIN	1	
11	95607-12200-00	NUT, U-FLANGE	2	
12	92907-12300-00	WASHER	2	
13	JR3-F3580-00-00	FRONT LOWER ARM, RIGHT	1	
14	JN6-F3526-00-00	.BUSHING, ARM	2	
15	JR3-F3502-00-00	KNUCKLE, STEERING RIGHT	1	
16	JN3-F3512-00-00	ARM, KNUCKLE	1	
17	90105-10360-00	BOLT, FLANGE	4	
18	95607-10200-00	NUT, U-FLANGE	2	
19	91490-25020-00	PIN, SPLIT	2	
20	J38-23527-00-00	SEAL, DUST 1	1	
21	JJ3-F3516-00-00	PIN, STEERING KNUCKLE	1	
22	90201-156J2-00	WASHER, PLAIN	1	
23	90105-10357-00	BOLT, FLANGE	4	
24	95607-10200-00	NUT, SELF-LOCKING	4	
25	91401-25020-00	PIN, SPLIT	4	
26	JJ3-F3350-00-00	SHOCK ABSORBER ASSY	2	
27	97007-10065-00	BOLT	2	

FIG. 13 FRONT SUSPENSION / WHEEL



JJ3110-3120

REF NO.	PART NUMBER	DESCRIPTION	QTY	REMARKS
28	97017-10050-00	BOLT	2	
29	95617-10100-00	NUT, U	4	
30	JG5-WF511-00-00	HUB	2	
31	93306-204X0-00	BEARING	2	
32	93306-005Y3-00	BEARING	2	
33	90387-241M7-00	COLLAR	2	
34	93102-30083-00	SEAL, OIL	2	
35	90209-32271-00	WASHER	2	
36	95607-14100-00	NUT, U	2	
37	91490-25020-00	PIN, SPLIT	2	
38	JN6-F5118-00-00	COVER, HUB DUST	2	
39	JN6-F5100-11-00	FR. WHEEL ASSY	2	
40	90179-12262-00	NUT	8	

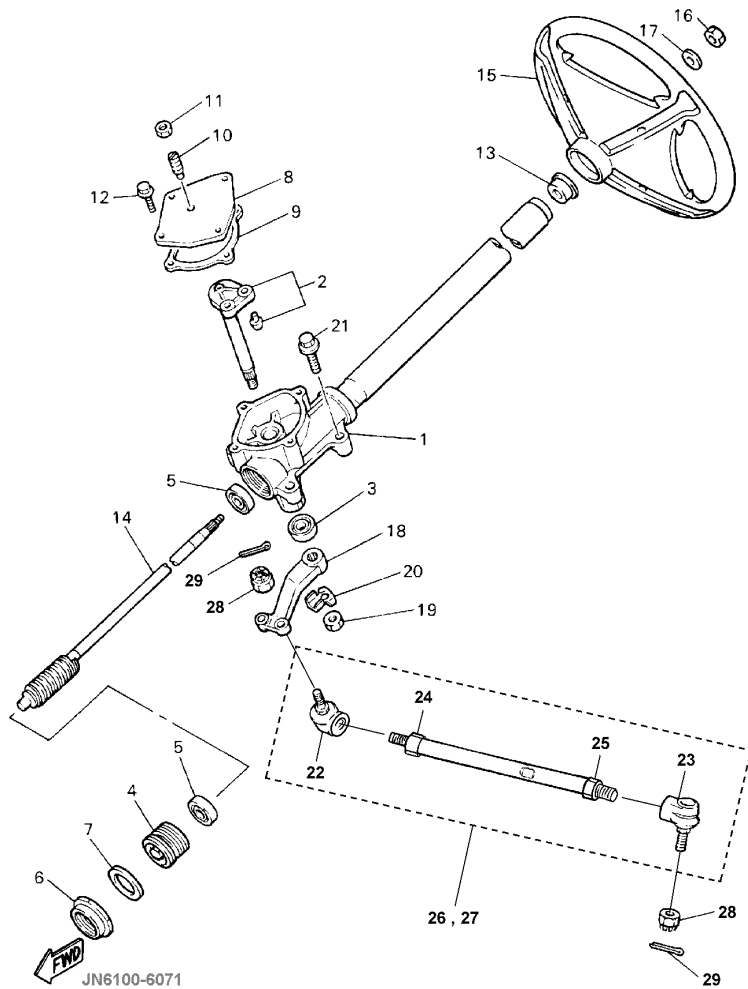

FIG. 14 STEERING

REF NO.	PART NUMBER	DESCRIPTION	QTY	REMARKS
1	JG5-F3811-00-00	COLUMN, STEERING	1	
2	J38-23816-00-00	ARM, PITMAN	1	
3	93102-22314-00	SEAL, OIL	1	
4	J55-F3876-00-00	BOLT	1	
5	93332-000Y2-00	BEARING	2	
6	J10-23877-00-00	NUT	1	
7	J10-23444-00-00	WASHER	1	
8	JN3-F3818-00-00	COVER, STEERING	1	
9	J38-23462-01-00	SEAL, STEERING	1	
10	J10-23459-00-00	BOLT	1	
11	90170-08024-00	NUT, HEX.	1	
12	95817-06020-00	BOLT, FLANGE	4	
13	JN3-F3814-00-00	HOLDER, HANDLE	1	
14	J10-23840-00-00	STEERING SHAFT	1	
15	JN3-F3838-00-00	WHEEL, STEERING	1	
16	95617-12100-00	NUT, SELF-LOCKING	1	
17	92907-12200-00	WASHER, PLAIN	1	
18	J38-23826-01-00	ARM, IDLER	1	
19	95707-16300-00	NUT, NYLON	1	
20	90215-16252-00	WASHER, TONGUE	1	
21	90105-100A4-00	BOLT, FLANGE	4	
22	JN6-F3845-00-00	UNIVERSAL JOINT	2	
23	JN6-F3841-00-00	UNIVERSAL JOINT	2	
24	95607-10200-00	NUT, (RH THREAD)	2	
25	90170-12054-00	NUT, (LH THREAD)	2	
26	JN3-F3850-11-00	TIE ROD ASSY, RIGHT	1	
27	JN3-F3830-11-00	TIE ROD ASSY, LEFT	1	

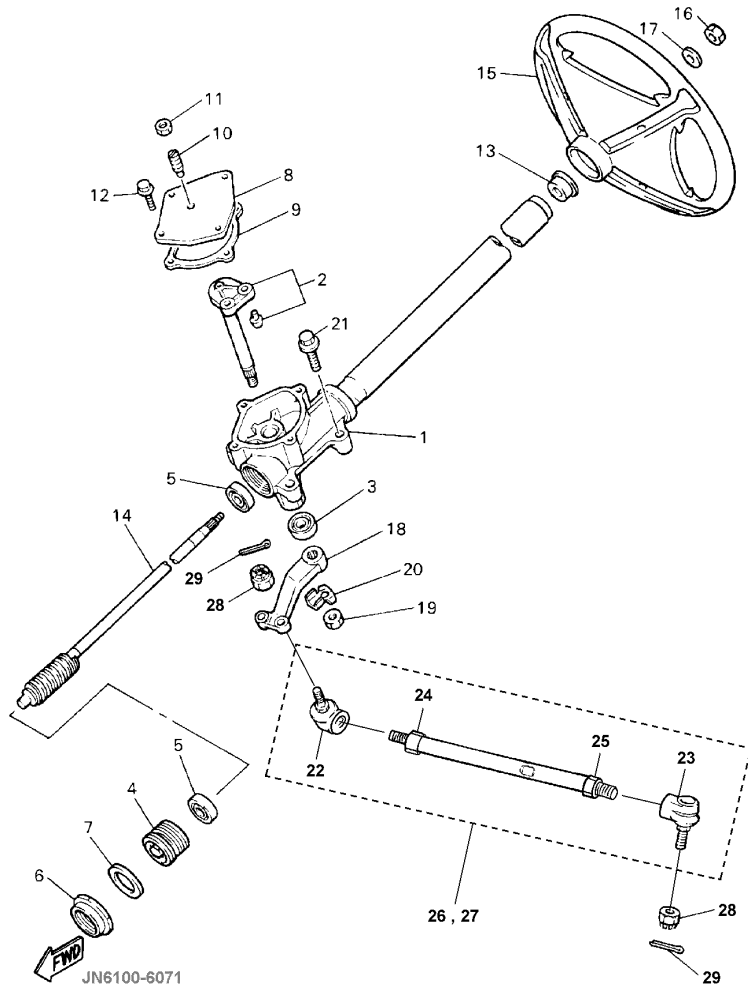

FIG. 14 STEERING

REF NO.	PART NUMBER	DESCRIPTION	QTY	REMARKS
28	95607-10200-00	NUT, U-FLANGE	4	
29	91490-25020-00	PIN, SPLIT	4	

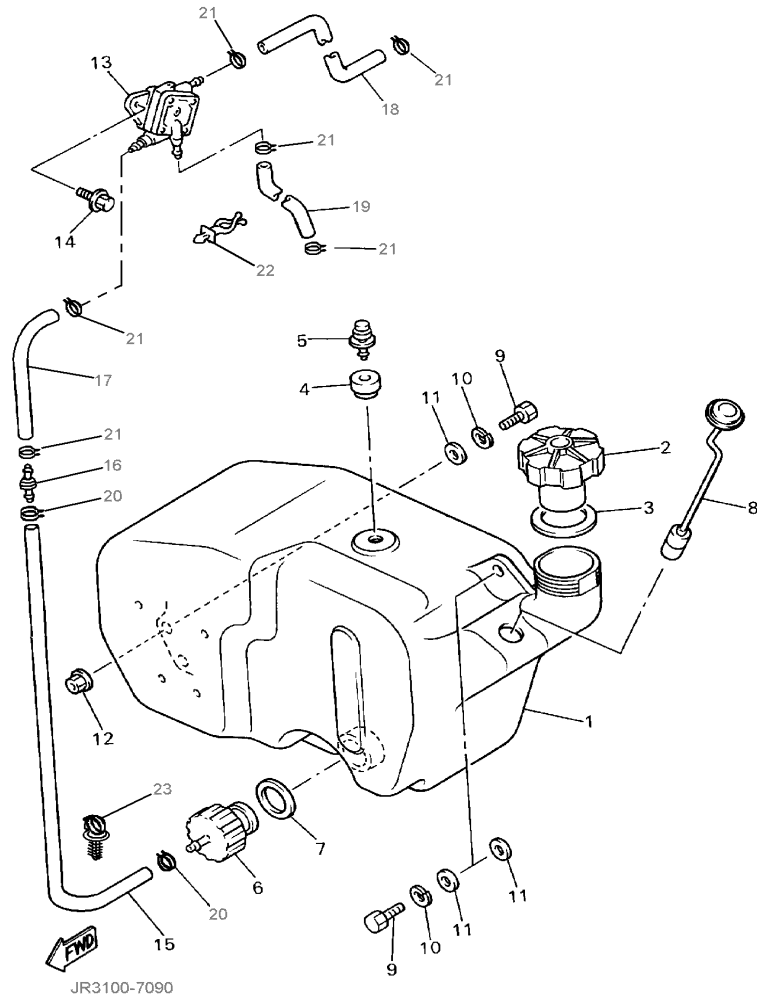

FIG. 15 FUEL TANK

REF NO.	PART NUMBER	DESCRIPTION	QTY	REMARKS
1	J55-F4111-11-00	TANK, FUEL	1	
2	J24-24620-01-00	BODY CAP ASSY	1	
3	J10-24612-00-00	GASKET, CAP	1	
4	J10-21773-00-00	GROMMET	1	
5	J24-24460-01-00	RELEASE VALVE ASSY.	1	
6	8R4-24560-00-00	FILTER ASSY.	1	
7	8F3-24564-00-00	GASKET	1	
8	J38-85710-02-00	FUEL LEVEL GAUGE ASSY.	1	
9	97007-08025-00	BOLT	3	
10	92907-08100-00	WASHER, SPRING	3	
11	90201-086A3-00	WASHER, PLATE	4	
12	95617-08200-00	NUT, SELF-LOCKING	2	
13	JN6-F4410-00-00	FUEL PUMP ASSY.	1	
14	95817-06016-00	BOLT, FLANGE	2	
15	JR3-F4312-00-00	PIPE 2	1	
16	JR3-F4461-00-00	PIPE, JOINT	1	
17	JN6-F4311-00-00	PIPE, FUEL	1	
18	JN6-F4313-00-00	PIPE 3	1	
19	JR3-F4314-00-00	PIPE 4	1	
20	90467-12845-00	CLIP	2	
21	90467-10846-00	CLIP	6	
22	90464-11816-00	CLAMP	1	
23	90464-12830-00	CLAMP	1	

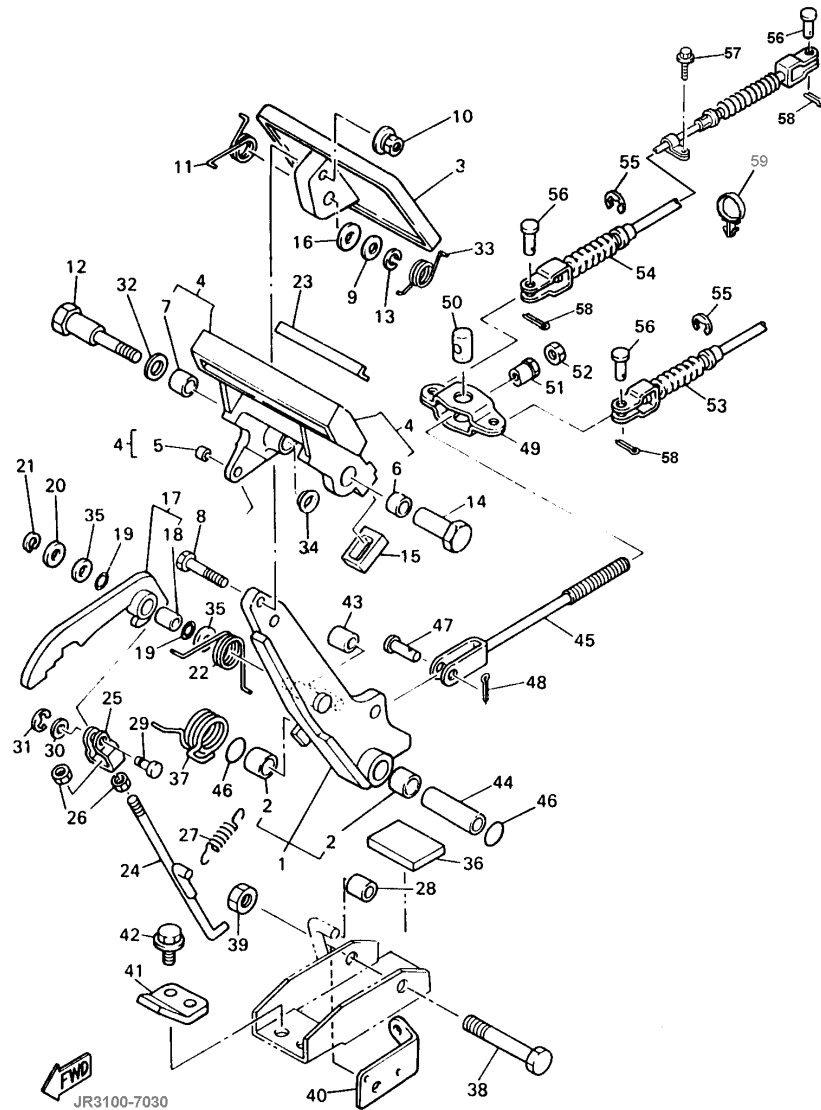

FIG. 16 BRAKE

REF NO.	PART NUMBER	DESCRIPTION	QTY	REMARKS
1	J46-27250-03-00	BRAKE ARM COMP	1	
2	90384-14080-00	.BUSH, BIMETAL FORMED	2	
3	J10-27211-00-00	PEDAL, BRAKE	1	
4	J17-25670-01-00	PARKING PEDAL COMP.	1	
5	90384-05163-00	.BUSH, BIMETAL	1	
6	90384-12164-00	.BUSH, BIMETAL	1	
7	90380-12051-00	.BUSH, SOLID	1	
8	90101-06555-00	BOLT, HEX.	1	
9	J55-27226-00-00	WASHER, LINK	1	
10	90179-06387-00	NUT	1	
11	90508-23542-00	SPRING,TORSION	1	
12	90109-08669-00	BOLT	1	
13	92907-08100-00	WASHER, SPRING	1	
14	90179-08378-00	NUT	1	
15	J17-25679-01-00	DAMPER	2	
16	92907-08200-00	WASHER, PLAIN	1	
17	J17-W2561-02-00	SECTOR, PARKING BRAKE	1	
18	90384-10162-00	.BUSH, BIMETAL	1	
19	J17-27221-00-00	SEAL, SHAFT	2	
20	92907-10600-00	WASHER, PLAIN	1	
21	99080-07600-00	CIRCLIP (E)	1	
22	90508-14548-00	SPRING, TORSION	1	
23	J17-25672-01-00	PAD, PARKING	1	
24	J17-27231-03-00	ROD, BRAKE	1	
25	J17-27232-00-00	END, ROD 1	1	
26	95317-06700-00	NUT, HEX.	2	
27	90506-08526-00	SPRING,TENSION	1	

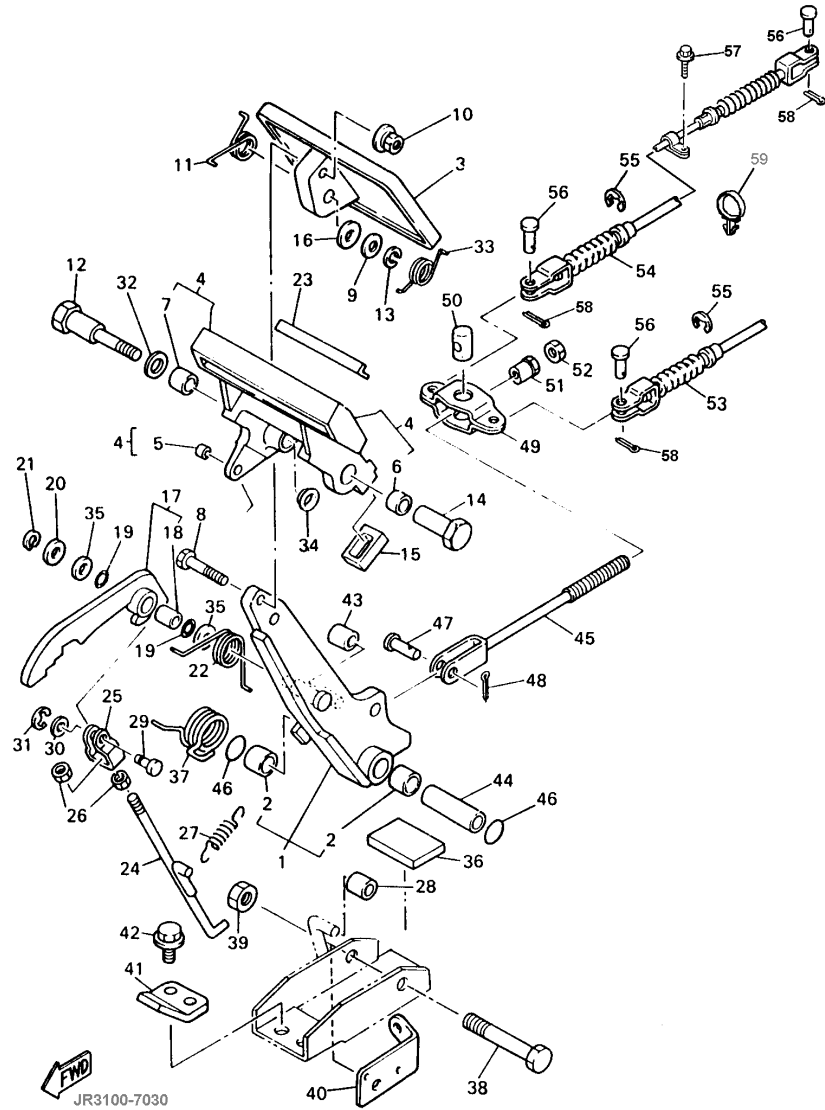

FIG. 16 BRAKE

REF NO.	PART NUMBER	DESCRIPTION	QTY	REMARKS
28	J17-25673-00-00	DAMPER, BRAKE	1	
29	J17-27228-00-00	PIN, LINK JOINT	1	
30	92907-05600-00	WASHER, PLAIN	1	
31	99080-04600-00	CIRCLIP (E)	1	
32	90201-123F2-00	WASHER, PLAIN	1	
33	90508-26557-00	SPRING, TORSION	1	
34	90380-12105-00	BUSH, SOLID	1	
35	90201-104G8-00	WASHER, PLAIN	2	
36	JN3-F7245-00-00	PAD, BRAKE PEDAL	1	
37	90508-405A9-00	SPRING, TORSION	1	
38	90101-10447-00	BOLT, HEX.	1	
39	95617-10200-00	NUT, U-FLANGE	1	
40	J55-2252M-00-00	BRACKET, 3	1	
41	J17-27246-00-00	NAIL, BRAKE	1	
42	95807-08020-00	BOLT, FLANGE	2	
43	J17-25673-00-00	DAMPER, BRAKE	1	
44	90387-107F8-00	COLLAR	1	
45	J20-25685-00-00	ROD	1	
46	93210-132A8-00	O-RING	2	
47	91701-10022-00	PIN	1	
48	91490-30020-00	PIN, SPLIT	1	
49	J10-25681-00-00	EQUALIZER, BRAKE	1	
50	90249-14129-00	PIN	1	
51	90179-08261-00	NUT	1	
52	95317-08700-00	NUT, HEX.	1	
53	JJ3-F6341-01-00	WIRE, BRAKE 1	1	
54	JJ3-F6351-02-00	WIRE, BRAKE 2	1	

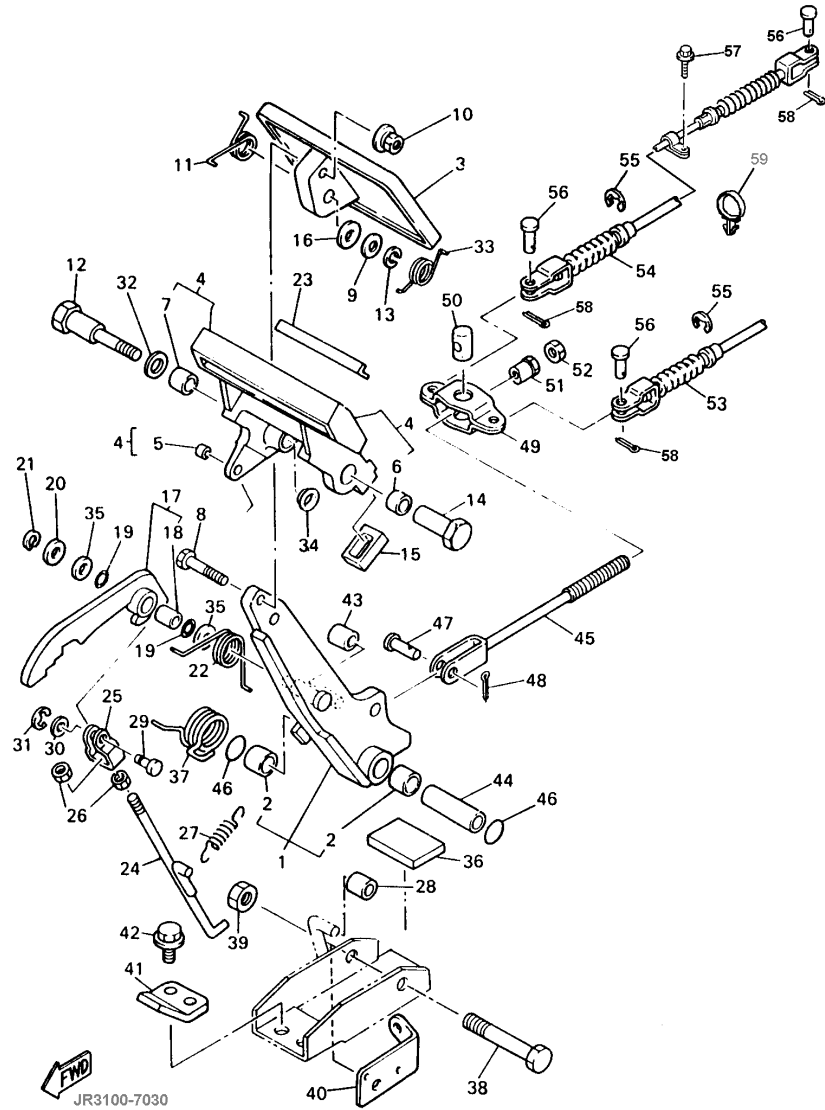
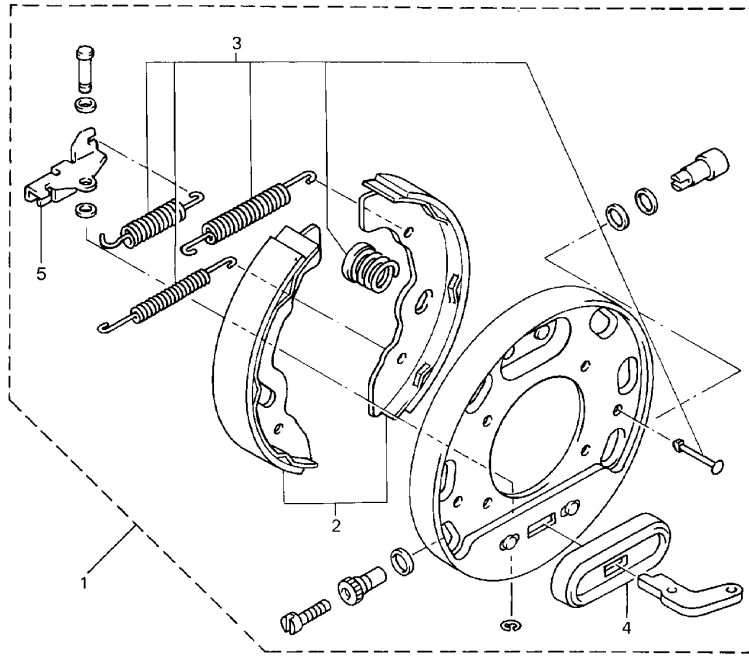

FIG. 16 BRAKE

REF NO.	PART NUMBER	DESCRIPTION	QTY	REMARKS
55	99001-09600-00	CIRCLIP (E)	4	
56	91701-08018-00	PIN	4	
57	95817-06016-00	BOLT, FLANGE	2	
58	91490-25020-00	PIN,SPLIT	4	
59	90464-19815-00	CLAMP	1	

FIG. 17 BRAKE 2



REF NO.	PART NUMBER	DESCRIPTION	QTY	REMARKS
1	JN6-F7280-00-00	BACKING PLATE, (RH)	1	(FOR RIGHT WHEEL ONLY)
2	JN3-F5340-00-00	.SHOE, BRAKE SET	1	(FOR ONE WHEEL)
3	JG5-F819G-00-00	.REPAIR PARTS KIT	1	
4	JG5-F7286-00-00	.COVER, DUST	1	
5	JN6-F722F-00-00	.LEVER ADJUSTER (RH)	1	

 JN4100-5061

FIG. 18 BRAKE 3

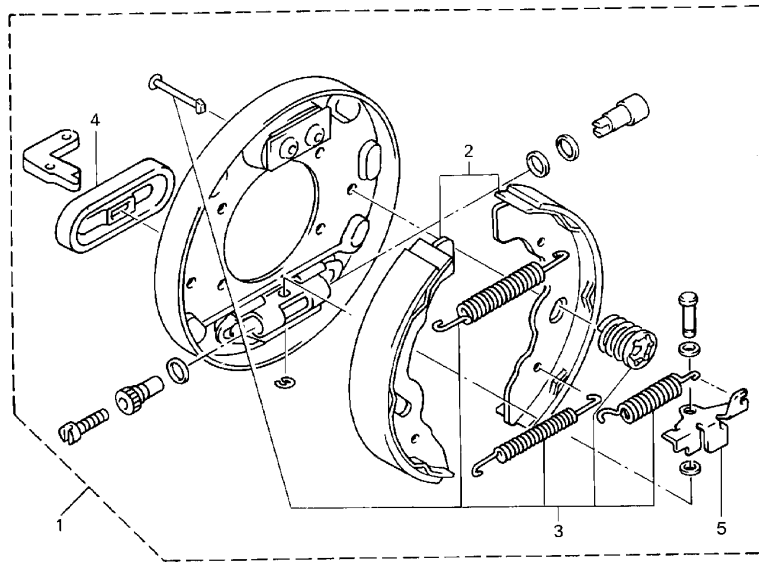

REF NO.	PART NUMBER	DESCRIPTION	QTY	REMARKS
1	JN6-F7290-00-00	BACKING PLATE, (LH)	1	(FOR LEFT WHEEL ONLY)
2	JN3-F5330-00-00	.SHOE, BRAKE SET	1	(FOR ONE WHEEL)
3	JG5-F819G-00-00	.REPAIR PARTS KIT	1	
4	JG5-F7286-00-00	.COVER, DUST	1	
5	JN6-F722E-00-00	.LEVER ADJUSTER (LH)	1	



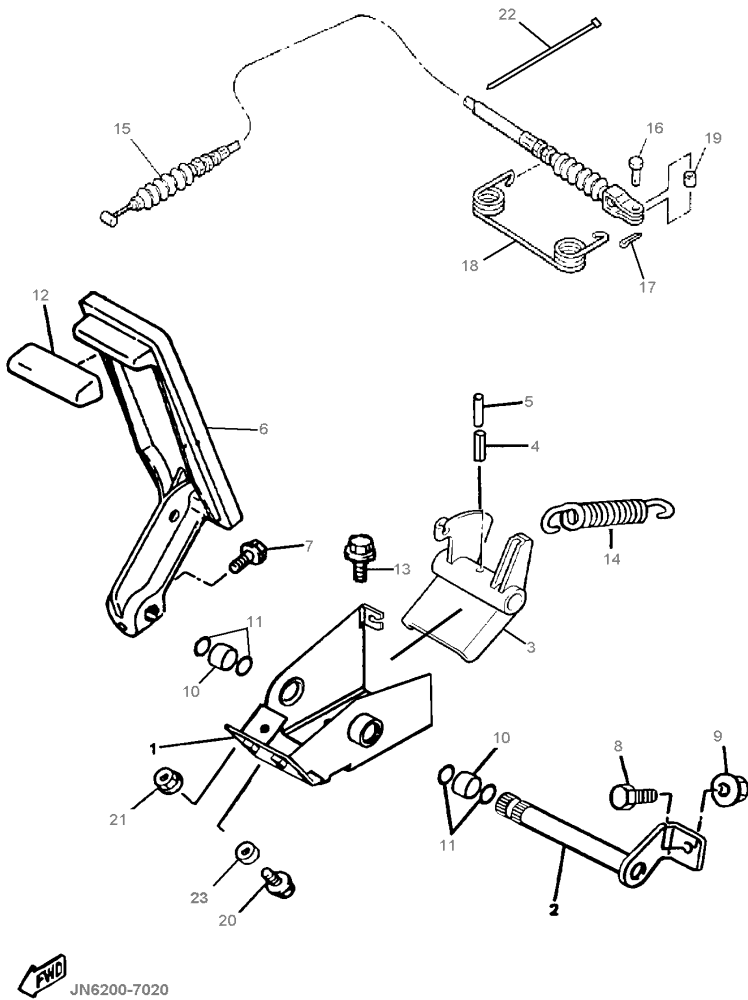
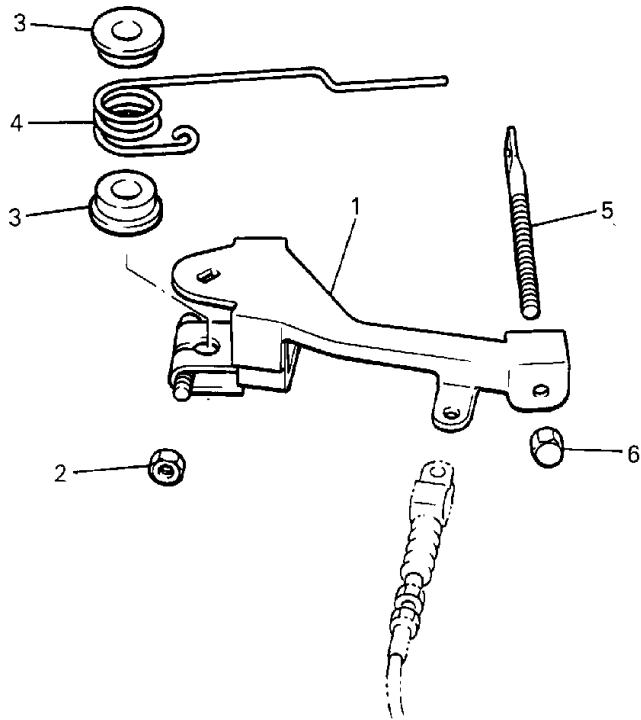

FIG. 19 ACCELERATOR

REF NO.	PART NUMBER	DESCRIPTION	QTY	REMARKS
1	JN6-F7874-01-00	BRACKET, PEDAL	1	
2	J17-27853-01-00	SHAFT, PEDAL	1	
3	J38-27872-00-00	ARM, ACCELERATOR	1	
4	91609-60028-00	PIN, SPRING	1	
5	91609-35028-00	PIN, SPRING	1	
6	JF3-27871-01-00	PEDAL, ACCELERATOR	1	
7	95817-06025-00	BOLT, FLANGE	1	
8	90106-08040-00	BOLT, RD. HEX	1	
9	95707-08500-00	NUT, FLANGE	1	
10	90384-14080-00	BUSH, BIMETAL	2	
11	93210-14104-00	O-RING	4	
12	JN3-F7854-00-00	COVER, PEDAL	1	
13	95817-08016-00	BOLT, HEX. H	3	
14	90506-26282-00	SPRING, TENSION	1	
15	JJ3-F6311-00-00	WIRE, THROTTLE	1	
16	91790-05012-00	PIN	1	
17	90468-10050-00	CLIP	1	
18	90508-16460-00	SPRING, TORSION	1	
19	90560-05001-00	SPACER	1	
20	95817-06025-00	BOLT, FLANGE	1	
21	95707-06500-00	NUT, FLANGE	1	
22	90601-200U1-00	BAND	1	
23	90387-068T4-00	COLLAR	1	



JN6100-6131

FIG. 20 GOVERNOR

REF NO.	PART NUMBER	DESCRIPTION	QTY	REMARKS
1	J38-27951-00-00	LEVER, SPEED	1	
2	95317-06600-00	NUT, HEX.	1	
3	90386-08141-00	BUSH	2	
4	90508-40678-00	SPRING, TORSION	1	
5	J38-27959-00-00	SCREW, ADJUSTING	1	
6	95607-06200-00	NUT, U-FLANGE	1	
7	JN3-G6555-00-00	BRACKET 2	1	
8	90105-08859-00	BOLT, FLANGE	1	

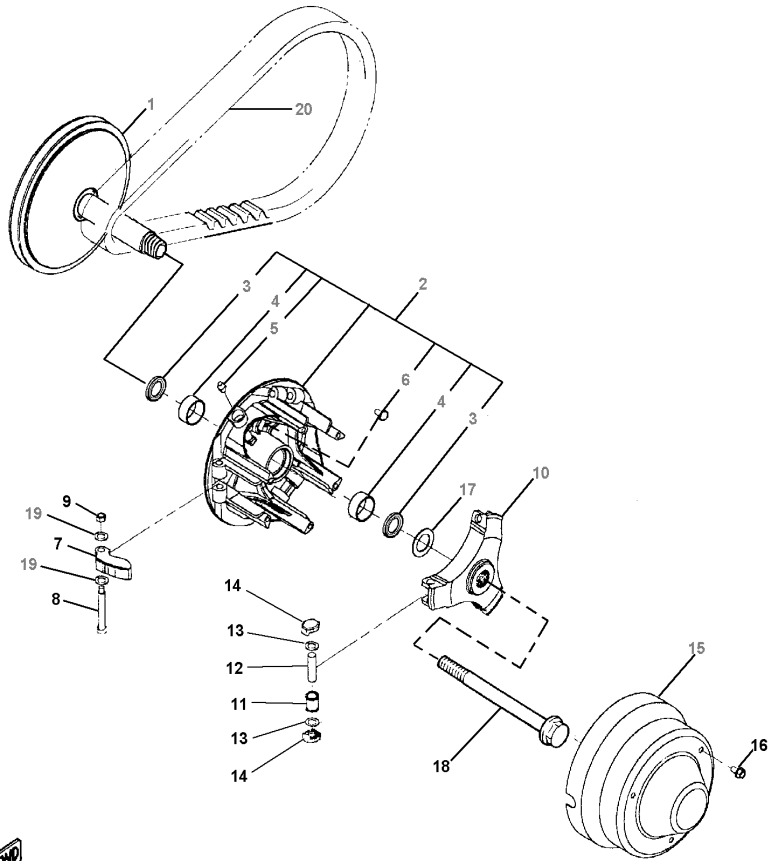

 JN6100-6140

FIG. 21 PRIMARY CLUTCH

REF NO.	PART NUMBER	DESCRIPTION	QTY	REMARKS
	JN6-G6201-00-00	PRIMARY CLUTCH ASSEMBLY	1	SEE NOTE "A"
1	JN6-G6210-00-00	PRIMARY FIXED SHEAVE	1	
2	JN6-G6220-00-00	PRIMARY SLIDING SHEAVE	1	
3	93101-28831-00	.SEAL, OIL	2	
4	90384-27823-00	.BUSH, BIMETAL	2	
5	93700-06810-00	.NIPPLE, GREASE	1	
6	90338-04840-00	.PLUG	3	
7	JN6-G6232-00-00	WEIGHT, 1	3	
8	90109-06860-00	BOLT	3	
9	90185-06834-00	NUT, SELF-LOCKING	3	
10	JN6-G6251-00-00	SPIDER	1	
11	JN6-G6258-01-00	COLLAR, ROLLER	3	
12	93610-358A3-00	PIN, DOWEL	3	
13	90201-098J1-00	WASHER, PLAIN	6	
14	JN6-G6253-00-00	SLIDER	6	
15	JN6-G6231-00-00	CAP	1	
16	90105-06861-00	BOLT, FLANGE	3	
17	90201-228K5-00	WASHER, PLAIN	1	
18	JN6-G6249-00-00	BOLT	1	
19	JN6-G621F-00-00	SHIM, THRUST	6	
20	J55-G6241-00-00	BELT	1	

NOTE "A": Assembly includes all parts except REF. Numbers 15, 16, 18 and 20 (the cap, 3 flange bolts for cap, the main bolt for the Primary Clutch assembly and the Belt).

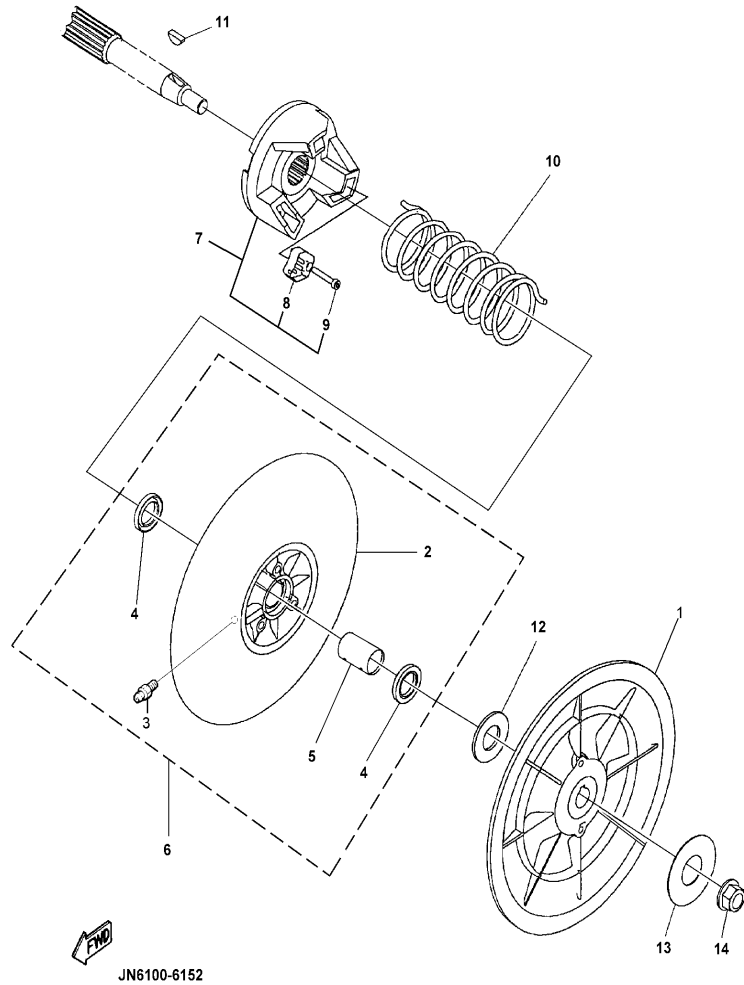
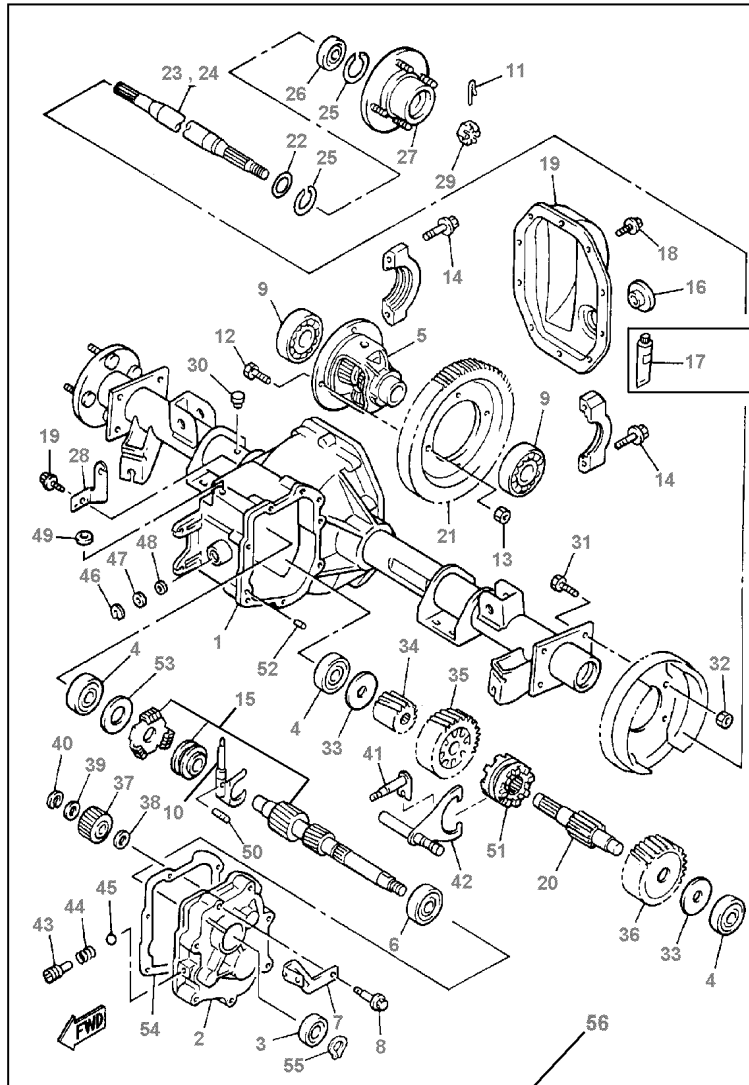

FIG. 22 SECONDARY SHEAVE

REF NO.	PART NUMBER	DESCRIPTION	QTY	REMARKS
1	JN6-G6260-00-00	SECONDARY FIXED SHEAVE	1	
2	JN6-G6271-02-00	SECONDARY SLIDING SHEAVE	1	
3	93700-06809-00	.NIPPLE, GREASE	1	
4	93109-20069-00	.SEAL, OIL	2	
5	90384-20143-00	BUSHING	1	
6	JN6-G6270-01-KT	SECONDARY SLIDING SHEAVE KIT	1	SEE NOTE "A"
7	JN6-G6280-00-00	SECONDARY SPRING SEAT	1	
8	JN6-E7688-00-00	.SHOE, RAMP	3	
9	90110-04834-00	.BOLT, HEX. SOCKET	3	
10	90508-45844-00	SPRING, TORSION	1	L=100.5mm±1.5
11	90202-20130-00	WASHER, PLAIN	1	
12	90280-05022-00	KEY, WOODRUFF	1	
13	90201-12588-00	WASHER, PLAIN	1	
14	95617-12200-00	NUT, U-FLANGE	1	

NOTE "A": Secondary sheave kit includes oil seals, bushing, and grease nipple.



JR2010-6222

FIG. 23 TRANSMISSION 1

REF NO.	PART NUMBER	DESCRIPTION	QTY	REMARKS
1	JR3-G6290-00-00	CASE ASSY	1	
2	JN3-G6313-00-00	COVER, TRANSMISSION	1	
3	93102-25868-00	SEAL, OIL	1	
4	93306-303Y6-00	BEARING	3	
5	JN6-G6410-00-00	DIFFERENTIAL ASSY.	1	
6	93306-005Y4-00	BEARING	1	
7	JN6-G6555-00-00	BRACKET, 2	1	
8	90105-08859-00	BOLT, FLANGE	7	
9	93306-007Y0-00	BEARING	2	
10	JN3-G633E-00-00	BAR, 1	1	
11	91490-25030-00	PIN, SPLIT	2	
12	90101-10854-00	BOLT, HEX.	4	
13	90170-10840-00	NUT, HEX.	4	
14	90105-10840-00	BOLT, FLANGE	4	
15	JR3-G6320-00-00	SHAFT, INPUT ASSY.	1	
16	JN3-G6432-00-00	STOPPER	1	
17	ACC-QUICK-GS-KT	SEALANT	1	
18	90101-08856-00	BOLT, HEX.	11	
19	JN3-G6314-00-00	COVER, TRANSMISSION	1	
20	JN3-G633G-00-00	SHAFT	1	
21	JN3-G6355-00-00	GEAR, PRIMARY	1	
22	93101-31836-00	SEAL, OIL	2	
23	JR3-G6511-00-00	SHAFT, RR. AXLE	1	
24	JR3-G6512-00-00	SHAFT, RR. AXLE	1	
25	93420-52806-00	CIRCLIP	4	
26	93306-205X2-00	BEARING	2	
27	JR3-G6514-00-00	HUB, RR. AXLE	2	

FIG. 23 TRANSMISSION 1

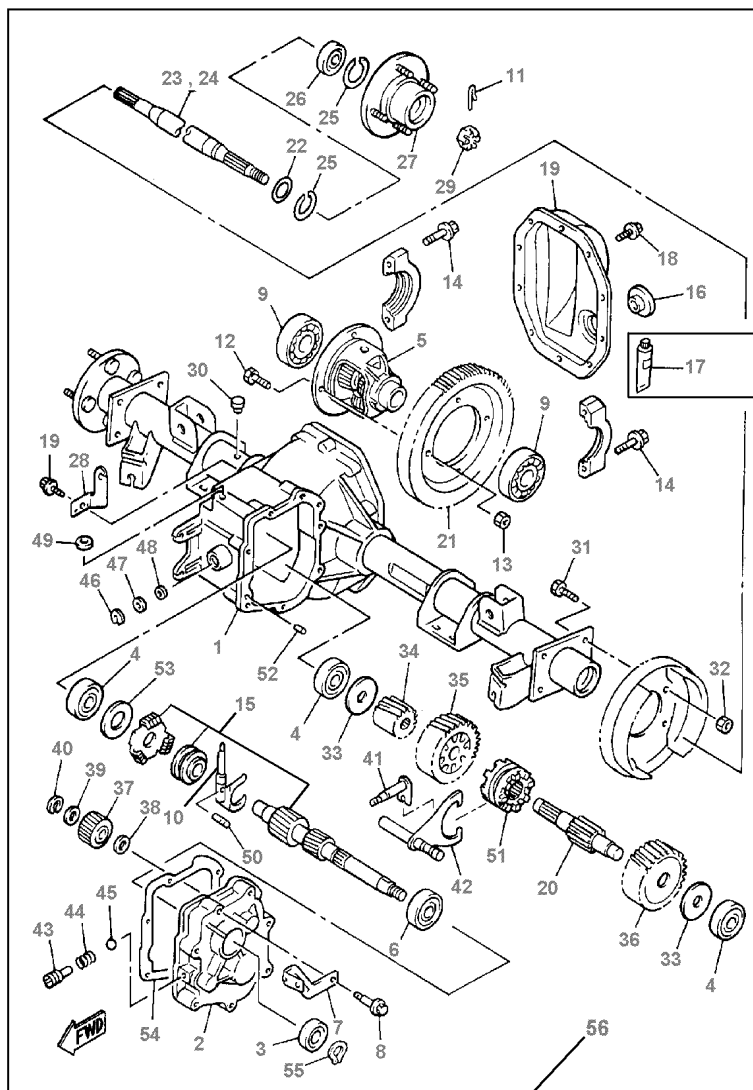

JR2010-6222

REF NO.	PART NUMBER	DESCRIPTION	QTY	REMARKS
28	JN3-G6556-00-00	BRACKET, 3	1	
29	90185-19842-00	NUT, SELF-LOCKING	2	
30	JH7-G5619-00-00	CAP	1	
31	90101-08855-00	BOLT, HEX.	8	
32	90170-08841-00	NUT, HEX.	8	
33	90201-178H8-00	WASHER, PLAIN	2	
34	JN3-G6316-00-00	GEAR, PINION	1	
35	JR3-G6326-00-00	GEAR, WHEEL 1	1	
36	JN3-G6327-00-00	GEAR, WHEEL 2	1	
37	JN3-G6356-00-00	GEAR, IDLER	1	
38	90201-208H9-00	WASHER, PLAIN	1	
39	90201-208J0-00	WASHER, PLAIN	1	
40	93440-20813-00	CIRCLIP	1	
41	JN3-G638A-00-00	BAR, SHIFT 1	1	
42	JN6-G638E-00-00	BAR, SHIFT 2	1	
43	90113-08803-00	BOLT, SET	1	
44	90501-10852-00	SPRING, COMPRESSION	1	
45	93500-06826-00	BALL	1	
46	93410-12822-00	CIRCLIP	1	
47	90202-12807-00	WASHER, PLAIN	1	
48	93104-11829-00	SEAL, OIL	1	
49	93109-10820-00	SEAL, OIL	1	
50	JN3-G6249-00-00	BOLT	1	
51	JN3-G6153-00-00	COLLAR, GUIDE	1	
52	93606-10842-00	PIN, DOWEL	2	
53	JN3-G6344-00-00	SHIM	1	0.76mm (0.030in)
	JN3-G6344-10-00	SHIM	1	0.90mm (0.035in)

FIG. 23 TRANSMISSION 1

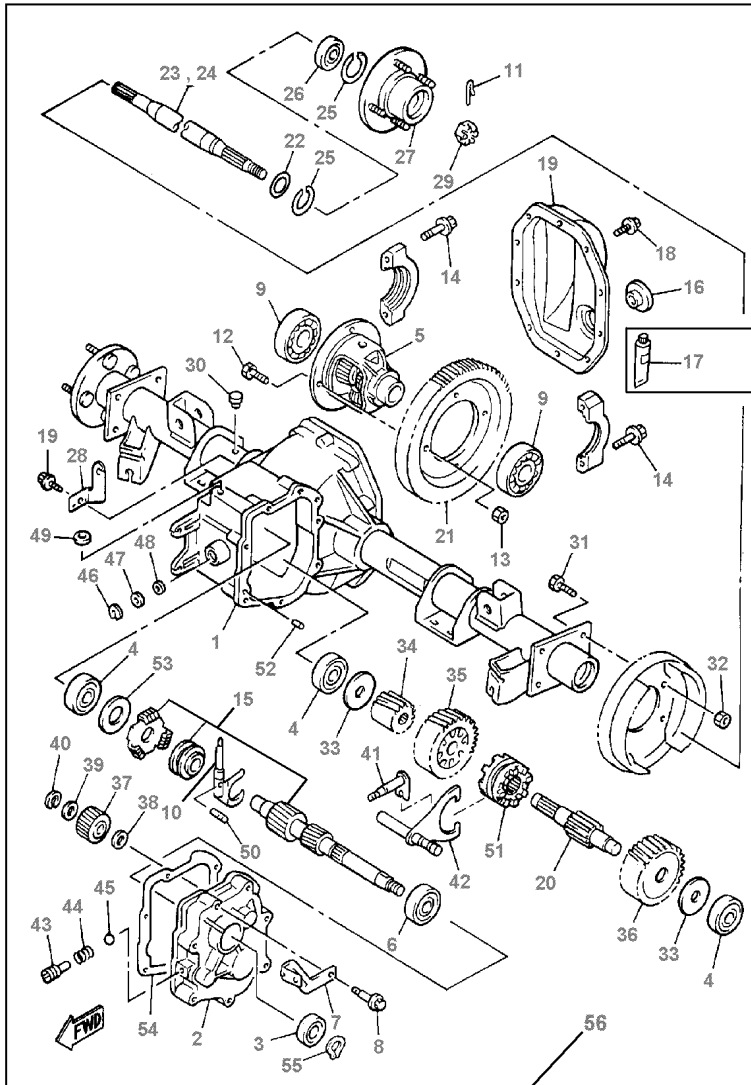

JR2010-6222

REF NO.	PART NUMBER	DESCRIPTION	QTY	REMARKS
	JN3-G6344-20-00	SHIM	1	1.0mm (0.040in)
	JN3-G6344-30-00	SHIM	1	1.14mm (0.045in)
	JN3-G6344-40-00	SHIM	1	1.27mm (0.050in)
	JN3-G6344-50-00	SHIM	1	1.39mm (0.055in)
	JN3-G6344-60-00	SHIM	1	1.52mm (0.060in)
	JN3-G6344-70-00	SHIM	1	1.65mm (0.065in)
	JN3-G6344-80-00	SHIM	1	0.38mm (0.015in)
54	JN3-G6319-00-00	GASKET	1	
55	93410-25017-00	CIRCLIP	1	
56	JR3-G6300-01-00	TRANSAXLE ASSEMBLY	1	

FIG. 24 REAR AXLE MOUNT / WHEEL

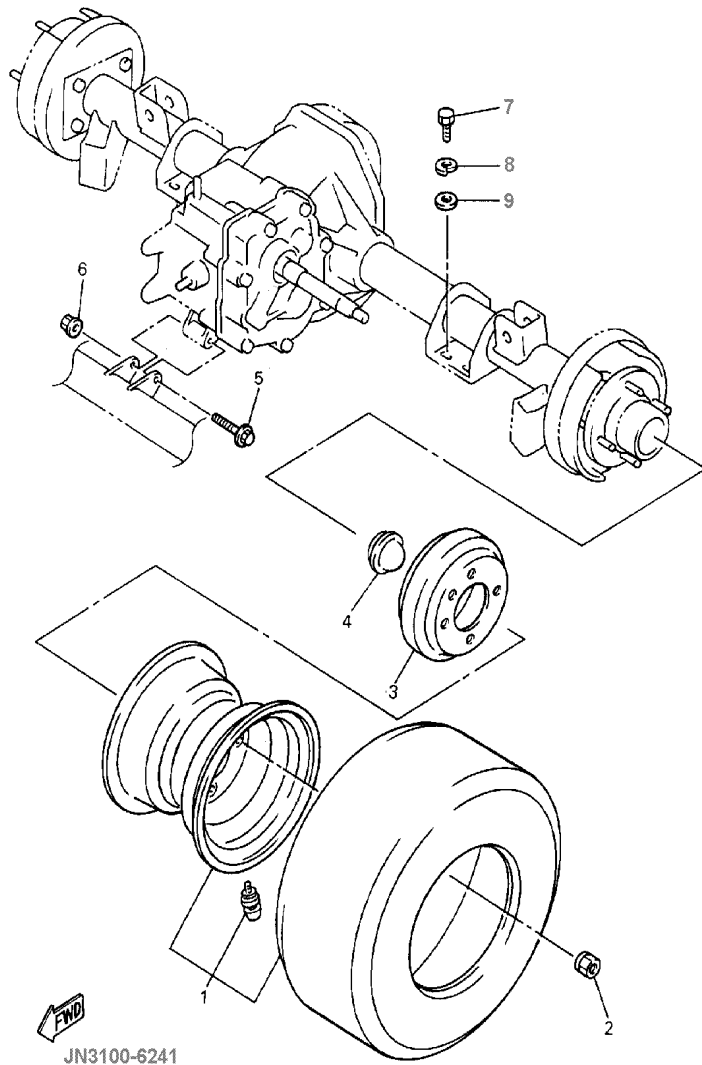

REF NO.	PART NUMBER	DESCRIPTION	QTY	REMARKS
1	JR3-F5300-00-00	WHEEL ASSY.	2	
2	90179-12262-00	NUT	8	
3	J55-G6521-00-00	DRUM	2	
4	JN6-F5118-00-00	COVER, HUB DUST	2	
5	95817-08075-00	BOLT, FLANGE	1	
6	95707-08500-00	NUT, FLANGE	1	
7	97017-10020-00	BOLT	8	
8	92907-10100-00	WASHER, LOCK	8	
9	90201-102G9-00	WASHER	8	

FIG. 25 SHIFTER / CABLES

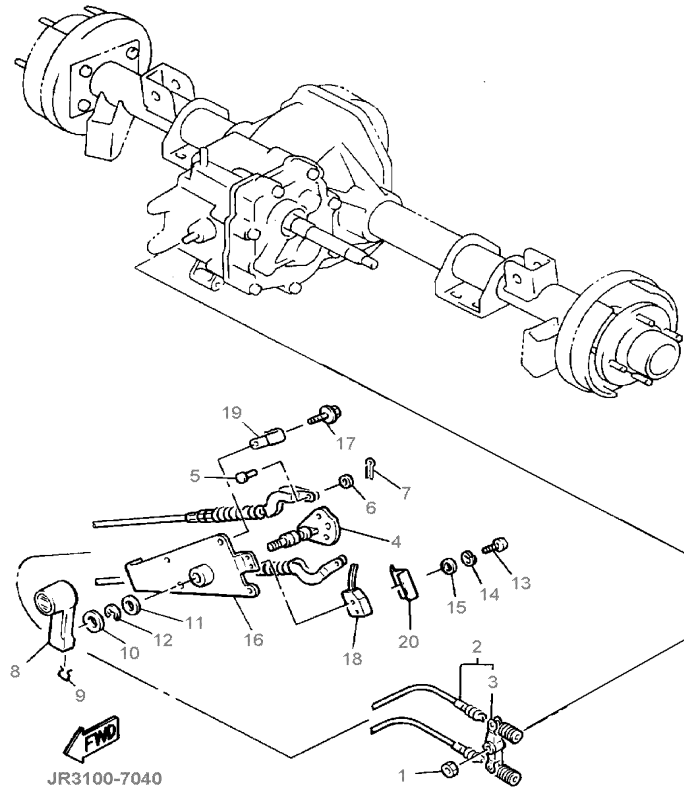

REF NO.	PART NUMBER	DESCRIPTION	QTY	REMARKS
1	95617-08100-00	NUT, U	1	
2	JJ3-G8330-010-00	CABLE, SHIFT	2	
3	J55-G6383-00-00	.LEVER, SHIFT 2	1	
4	JF2-46382-00-00	LEVER, SHIFT 1	1	
5	91702-06014-00	PIN	2	
6	92907-06600-00	WASHER, PLAIN	2	
7	91490-20025-00	PIN, SPLIT	2	
8	JN3-G6381-00-00	KNOB, SHIFT	1	
9	JN3-G6376-00-00	SPRING SET	1	
10	90201-201L9-00	WASHER, PLAIN	1	
11	90201-19551-00	WASHER, PLAIN	1	
12	99009-19400-00	CIRCLIP (S)	1	
13	98507-04016-00	SCREW, PANHEAD	2	
14	92907-04100-00	WASHER, LOCK	2	
15	92907-04600-00	WASHER	2	
16	JN3-G6372-00-00	BRACKET, SHIFT	1	
17	95817-06016-00	BOLT, FLANGE	4	
18	JN3-82617-00-00	SWITCH	1	
19	90465-06038-00	CLAMP	1	
20	JJ3-G6394-00-00	JOINT	1	

FIG. 26 BUMPER

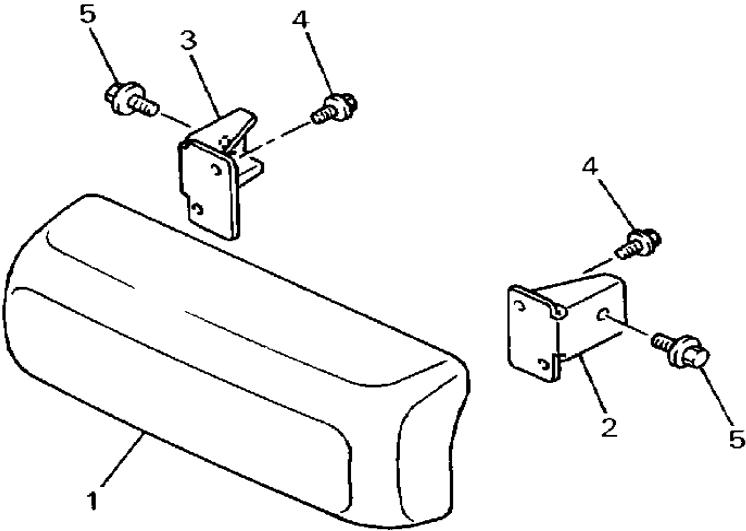

REF NO.	PART NUMBER	DESCRIPTION	QTY	REMARKS
1	JN3-K7510-02-00	FRONT BUMPER COMP.	1	
2	JN3-K8164-00-00	STAY, FR. BUMPER	1	
3	JN3-K8165-00-00	STAY, FR. BUMPER	1	
4	95817-06016-00	BOLT, FLANGE	4	
5	95817-08016-00	BOLT, FLANGE	2	

 JR3100-7050

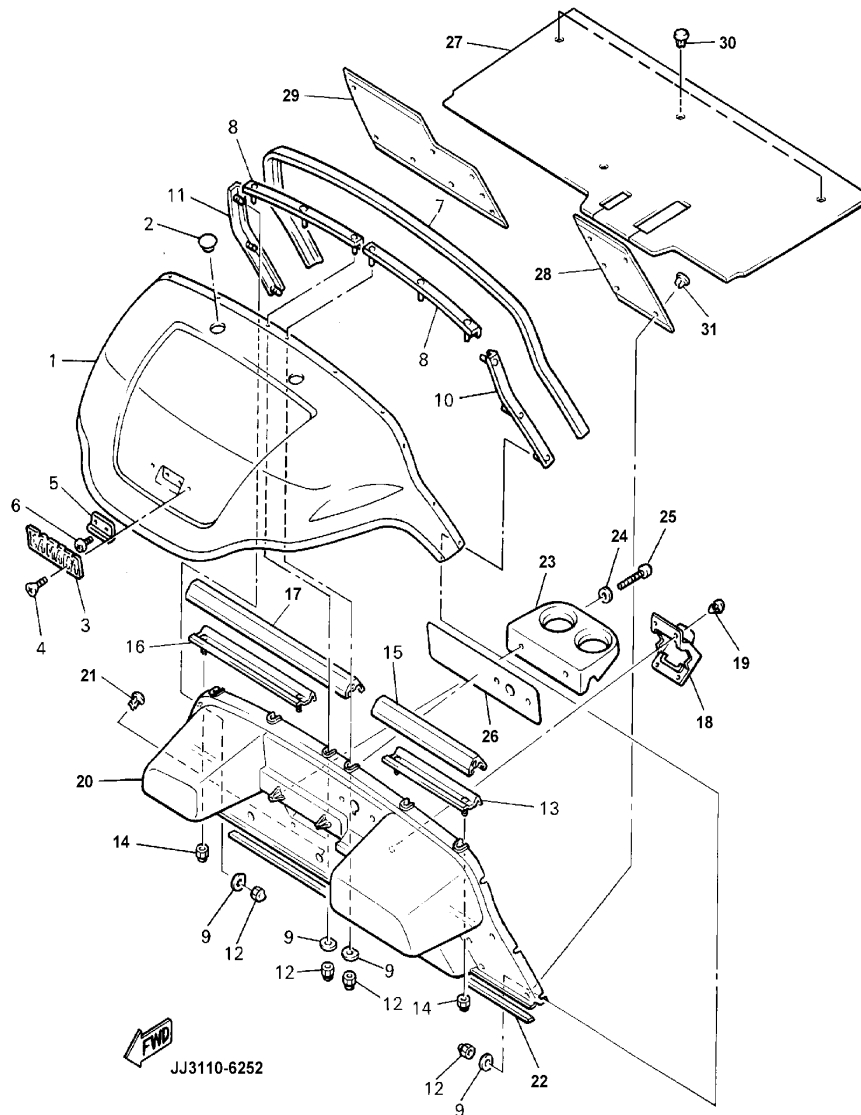
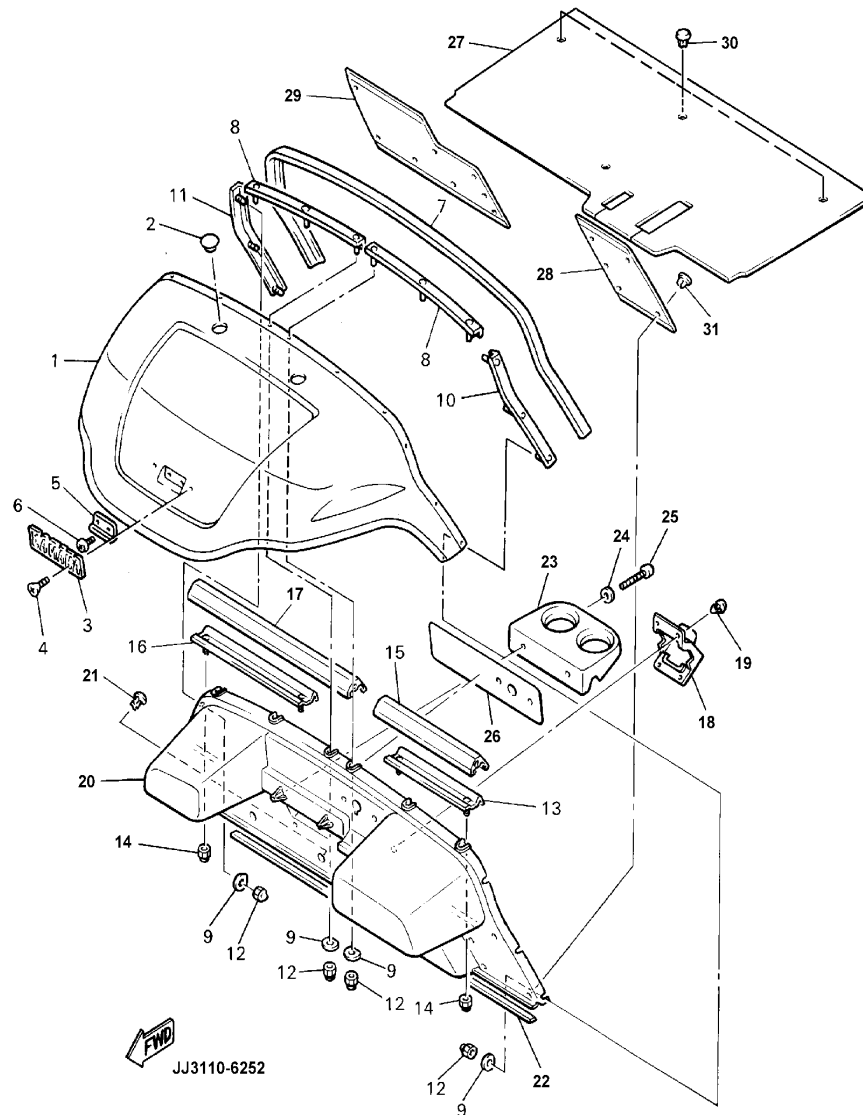

FIG. 27 BODY

REF NO.	PART NUMBER	DESCRIPTION	QTY	REMARKS
1	JN3-K8115-20-00	COWL, FRONT	1	GRAY
2	JN3-K818E-00-00	CAP, PROTECTOR	2	
3	JN6-F4161-00-00	EMBLEM, 1	1	
4	90162-04002-00	SCREW, OVAL C	2	
5	JF2-K811G-00-00	BOLT, COWL FITTING	1	
6	98980-06016-00	SCREW, BINDING	2	
7	JF2-K811V-00-00	PROTECTOR, 1	1	
8	JF2-K8261-02-00	PLATE, BODY PROTECTOR	2	
9	JN3-K8117-00-00	PLATE, 1	12	
10	JF2-K8262-01-00	PLATE, BODY PROTECTOR	1	
11	JF2-K8263-01-00	PLATE, BODY PROTECTOR	1	
12	90185-06836-00	NUT, SELF-LOCKING	12	
13	JF2-K8264-00-00	PLATE, BODY PROTECTOR	1	
14	95607-06200-00	NUT, U-FLANGE	24	
15	JF2-K811W-00-00	PROTECTOR 2	1	
16	JF2-K8265-00-00	PLATE, BODY PROTECTOR	1	
17	JF2-K811X-00-00	PROTECTOR 3	1	
18	JF2-78273-00-00	COVER, HOLE 1	1	
19	90269-11042-00	RIVET	4	
20	JF2-K8114-02-00	PANEL, FRONT	1	SEE NOTE "A"
21	90269-08069-00	RIVET	3	
22	JN3-K815G-00-00	SEAL, FRONT STORAGE	1	
23	JF2-K835E-00-00	HOLDER, BEVERAGE	1	
24	90201-060A3-00	WASHER, PLATE	2	
25	97707-60130-00	SCREW, TAPPING	2	
26	JJ3-K7761-00-00	LABEL, WARNING 1	1	SEE NOTE "A"

NOTE "A": When replacing "Panel Front JF2-K8114-02-00" you should also replace "Label Warning 1 JJ3-K7761-00-00".

FIG. 27 BODY



REF NO.	PART NUMBER	DESCRIPTION	QTY	REMARKS
27	JN6-K8233-00-00	MAT, MAIN FLOOR 3	1	
28	JN6-K8231-00-00	MAT, MAIN FLOOR 1	1	
29	JN6-K8232-00-00	MAT, MAIN FLOOR 2	1	
30	90269-08813-00	RIVET	4	
31	90267-63047-00	RIVET, BLIND	9	

FIG. 28 BODY 2

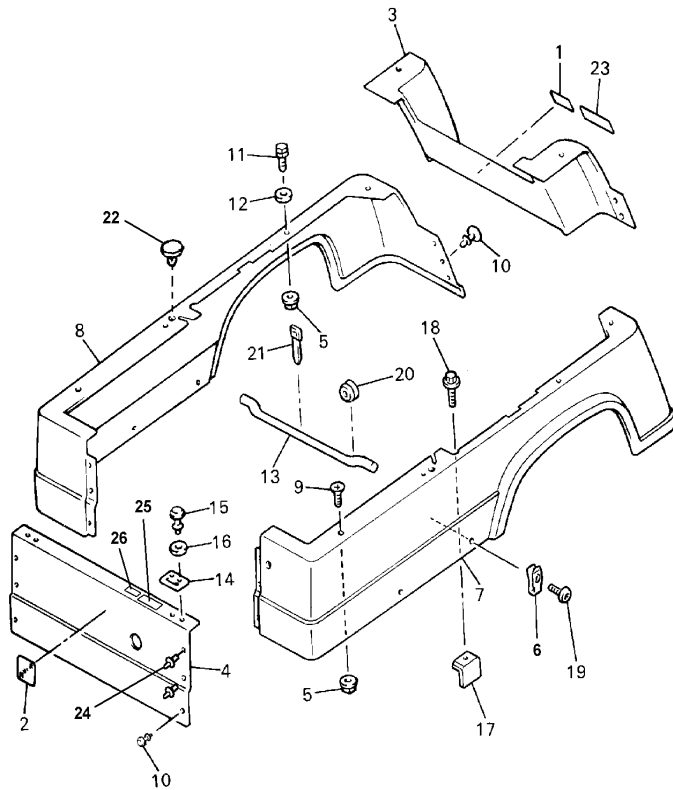

JJ3110-6262

REF NO.	PART NUMBER	DESCRIPTION	QTY	REMARKS
1	JJ3-K7765-00-00	LABEL, WARNING 5	1	SEE NOTE "A"
2	JN3-K7741-00-00	INDICATOR 1	1	SEE NOTE "B"
3	JJ3-K8142-11-00	PANEL, REAR BODY	1	SEE NOTE "A"
4	JJ3-K8141-10-00	PANEL, INTERMEDIATE BODY	1	SEE NOTE "B"
5	90183-06810-00	NUT, SPRING	10	
6	90183-06811-00	NUT, SPRING	4	
7	JJ3-K8111-12-00	PANEL, BODY SHELL	1	
8	JJ3-K8112-12-00	PANEL, BODY SHELL	1	
9	90151-06040-00	SCREW, COUNTERSUNK	2	
10	90267-62841-00	RIVET, BLIND	6	
11	90119-06929-00	BOLT, WITH WASHER	8	
12	90201-065F3-00	WASHER, PLATE	8	
13	JJ3-K8226-00-00	ROD, SEAT STOPPER	1	
14	JJ3-K8427-01-00	HINGE, SEAT 2	2	
15	90267-64834-00	RIVET, BLIND	4	
16	90201-08681-00	WASHER, PLATE	4	
17	JJ3-K814H-00-00	HOOK, BODY LOCK	2	
18	90119-08903-00	BOLT, WITH WASHER	2	
19	90110-06200-00	BOLT, HEXAGON SOCKET HEAD	4	
20	90480-13018-00	GROMMET	1	
21	90464-10814-00	CLAMP	1	
22	JJ3-K8167-01-00	BUMPER, RUBBER 1	2	
23	JJ3-K7768-00-00	LABEL, WARNING 8	1	SEE NOTE "A"

NOTE "A": When replacing "Panel Rear Body JJ3-K8142-11-00" you must also replace "Label Warning 5 JJ3-K7765-00-00", and "Label Warning 8 JJ3-K7768-00-00".

NOTE "B": When replacing "Panel Intermediate Body JJ3-K8141-10-00" you must also replace "Indicator 1 JN3-K7741-00-00".

FIG. 28 BODY 2

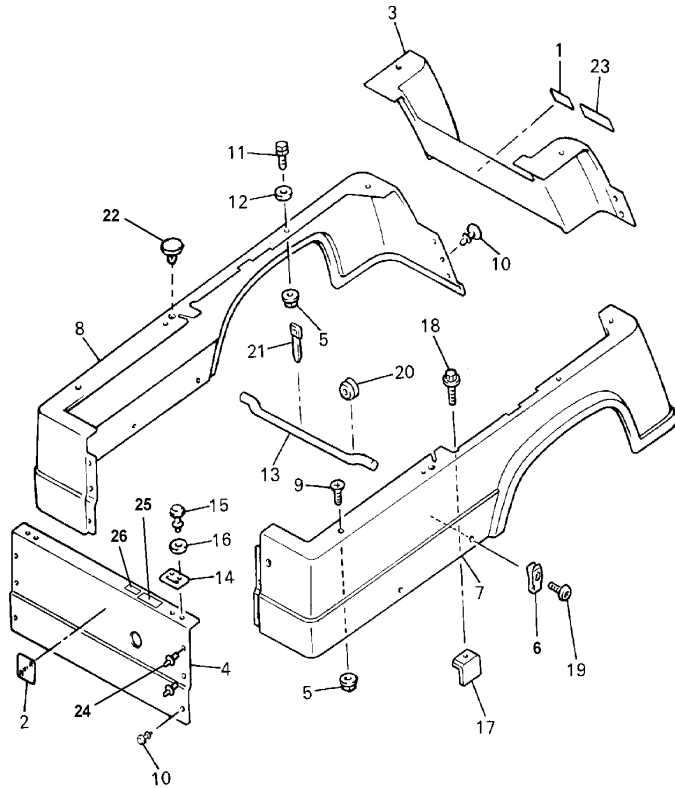

REF NO.	PART NUMBER	DESCRIPTION	QTY	REMARKS
24	90267-36853-00	RIVET, BLIND	4	
25	JR3-F4236-00-00	MARK 2	1	UR, F# JR3-100500~JR3-101000
	JR3-F4236-10-00	MARK 2	1	UR, F# JR3-200101~JR3-201000
25	JR3-F4236-00-00	MARK 2	1	UR, F# JR3-100500~JR3-101000
	JR3-F4236-10-00	MARK 2	1	UR, F# JR3-200101~JR3-201000
	JR3-F4236-20-00	MARK 2	1	UR, F# JR3-300101~
26	JR3-F4236-10-00	MARK 5	1	UR, F# JR3-200101~JR3-201000

 JJ3110-6262

FIG. 29 BODY FITTING

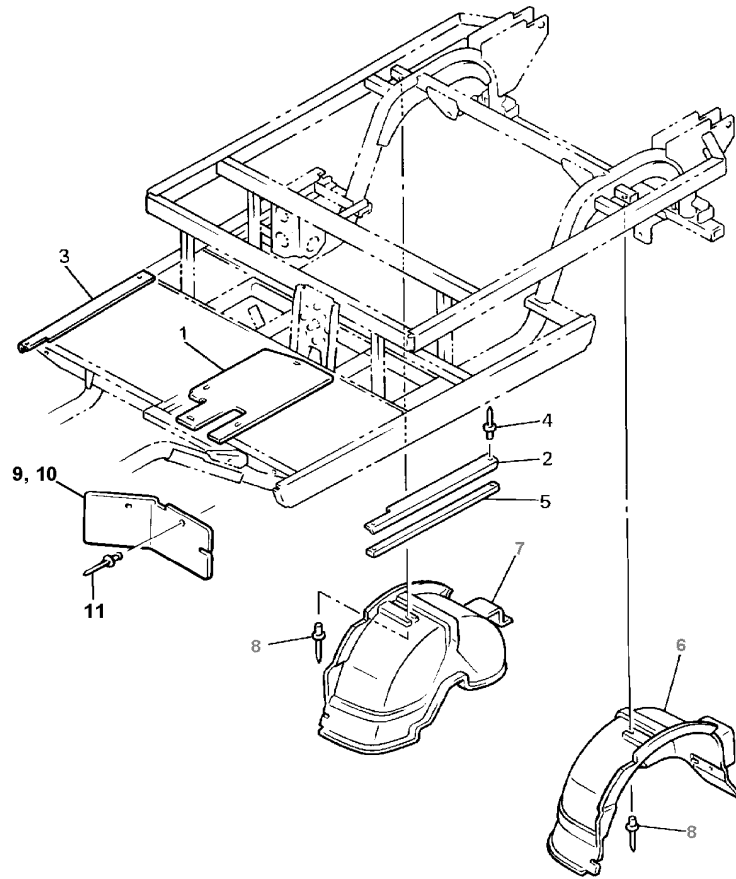

REF NO.	PART NUMBER	DESCRIPTION	QTY	REMARKS
1	JN6-K8271-00-00	SERVICE LID	1	
2	JF2-K8215-10-00	PLATE, SIDE TRIM	1	
3	JF2-K821F-10-00	PLATE, SIDE TRIM	1	
4	90267-48154-00	RIVET, BLIND	4	
5	JJ3-K8124-00-00	REINFORCEMENT 4	2	
6	JJ3-K8191-00-00	PANEL, REAR FENDER 1	1	
7	JJ3-K8192-00-00	PANEL, REAR FENDER 2	1	
8	90267-48101-00	RIVET, BLIND	6	
8	JF2-K8187-00-00	FLAP, FRONT FENDER LEFT	1	F# JR3-100101~
9	JF2-K8189-00-00	FLAP, FRONT FENDER RIGHT	1	F# JR3-100101~
10	90267-48831-00	RIVET, BLIND	4	F# JR3-100101~



JR3100-7060

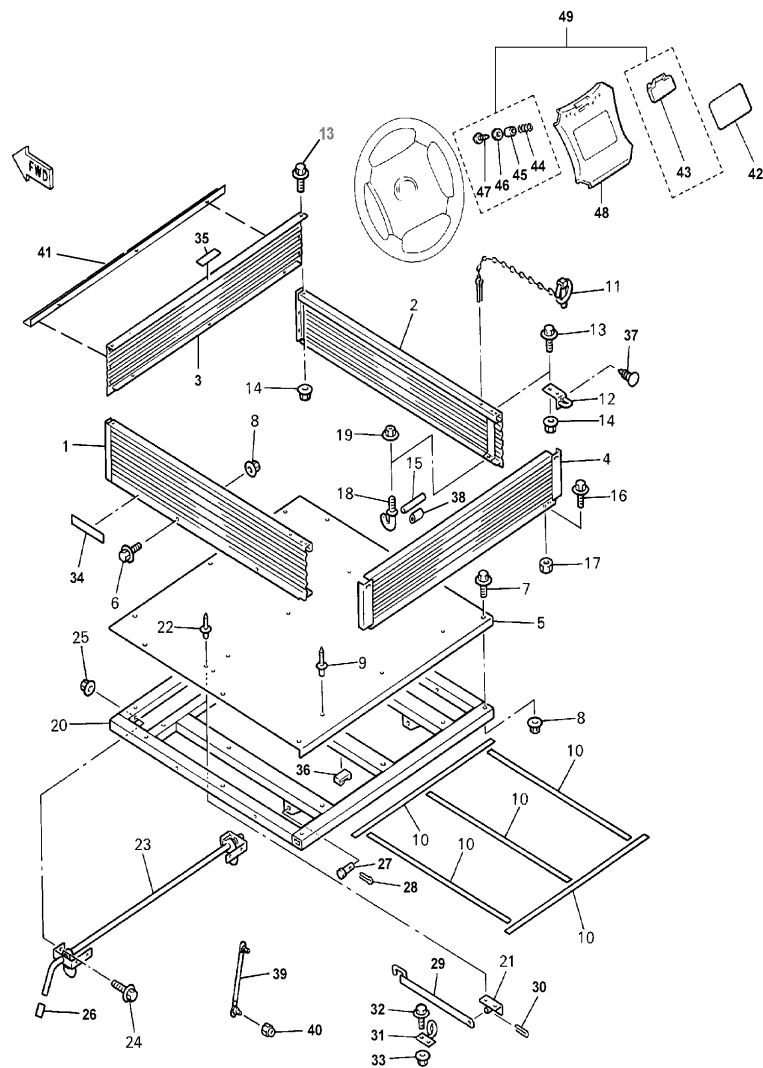

JJ3110-6284

FIG. 30 CARRIER

REF NO.	PART NUMBER	DESCRIPTION	QTY	REMARKS
1	JJ3-K810F-00-00	SIDE PANEL COMP. (LH)	1	SEE NOTE "A"
2	JJ3-K810G-00-00	SIDE PANEL COMP. (RH)	1	
3	JJ3-K7782-00-00	PANEL, DASH 2	1	SEE NOTE "B"
4	JJ3-K810N-00-00	REAR STORAGE LID COMP.	1	
5	JJ3-K8117-00-00	PLATE 1	1	
6	90119-08038-00	BOLT, WITH WASHER	19	
7	90119-08925-00	BOLT, WITH WASHER	2	
8	95617-08200-00	NUT, SELF-LOCKING	21	
9	90267-64844-00	RIVET, BLIND	6	
10	JJ3-K821A-00-00	PAD, BODY MOUNTING 1	5	
11	JR3-K8156-00-00	STOPPER, LOCK	2	F# JR3-100950~
12	JJ3-K8317-00-00	RING, HOOK	2	
13	90119-06908-00	BOLT, WITH WASHER	6	
14	95607-06200-00	NUT, SELF-LOCKING	6	
15	JJ3-K8384-00-00	BOLT	2	
16	97017-06020-00	BOLT	4	
17	95380-06700-00	NUT	4	
18	JJ3-K8385-00-00	BOLT 2	2	
19	95617-08200-00	NUT, SELF-LOCKING	2	
20	JJ3-K818N-00-00	BED, BOX	1	
21	JJ3-K8376-00-00	SUPPORT 2	1	
22	90267-64844-00	RIVET, BLIND	2	
23	JJ3-K8380-03-00	LOCK ASSY	1	
24	958107-08020-00	BOLT, FLANGE	6	
25	95617-08200-00	NUT, SELF-LOCKING	6	
26	JJ3-K818M-00-00	CAP, PROTECTOR END 4	1	
27	90240-13808-00	PIN, CLEVIS	2	

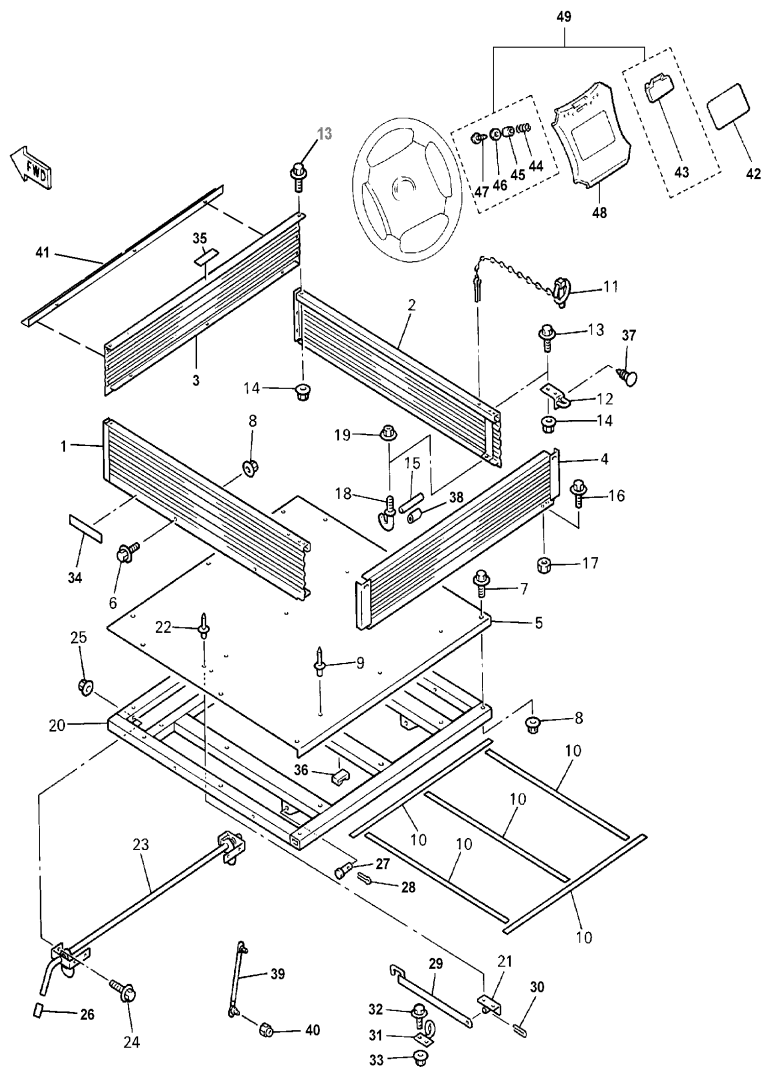

JJ3110-6284

FIG. 30 CARRIER

REF NO.	PART NUMBER	DESCRIPTION	QTY	REMARKS
28	91490-30030-00	PIN, COTTER	2	
29	JJ3-K8158-01-00	ROD, INSPECTION LID	1	
30	91490-20025-00	PIN, COTTER	1	
31	JJ3-K8369-00-00	PIN, LEVER	1	
32	90119-06908-00	BOLT, WITH WASHER	2	
33	95607-06200-00	NUT, SELF-LOCKING	2	
34	JJ3-K7764-01-00	LABEL, WARNING 4	1	SEE NOTE "A"
35	JJ3-K7766-01-00	LABEL, WARNING 6	1	SEE NOTE "B"
36	JJ3-K815H-00-00	DAMPER, LOCK	1	
37	90338-05830-00	PLUG	4	
38	JR3-K8316-00-00	DAMPER	2	
39	JJ3-K7588-00-00	DAMPER 1	1	
40	95617-08200-00	NUT, SELF-LOCKING	2	
41	JR3-K8323-00-00	BRACKET, 1	1	F# JR3-100501~
42	JN3-K7762-01-00	LABEL, WARNING 2	1	SEE NOTE "C"
43	JN6-K8358-00-00	HOLDER 2	1	
44	90502-10013-00	SPRING, CONICAL	2	
45	90387-046N7-00	COLLAR	2	
46	90201-044H9-00	WASHER, PLAIN	2	
47	97707-40625-00	SCREW, PAN HEAD	2	
48	JN3-K8357-00-00	HOLDER 1	1	SEE NOTE "C"
49	JN6-K8358-00-KT	INFORMATION HOLDER KIT	1	SEE NOTE "D"

NOTE "A": When replacing "Side Panel Comp (LH) JJ3-K810F-00-00" you must also replace "Label Warning 4 JJ3-K7764-01-00".

NOTE "B": When replacing "Panel Dash 2 JJ3-K7782-00-00" you must also replace "Label Warning 6 JJ3-K7766-01-00".

NOTE "C": When replacing "Holder 1 JN3-K8357-00-00" you must also replace "Label Warning 2 JN3-K7762-01-00".

NOTE "D": Includes 43, 44, 45, 46, 47

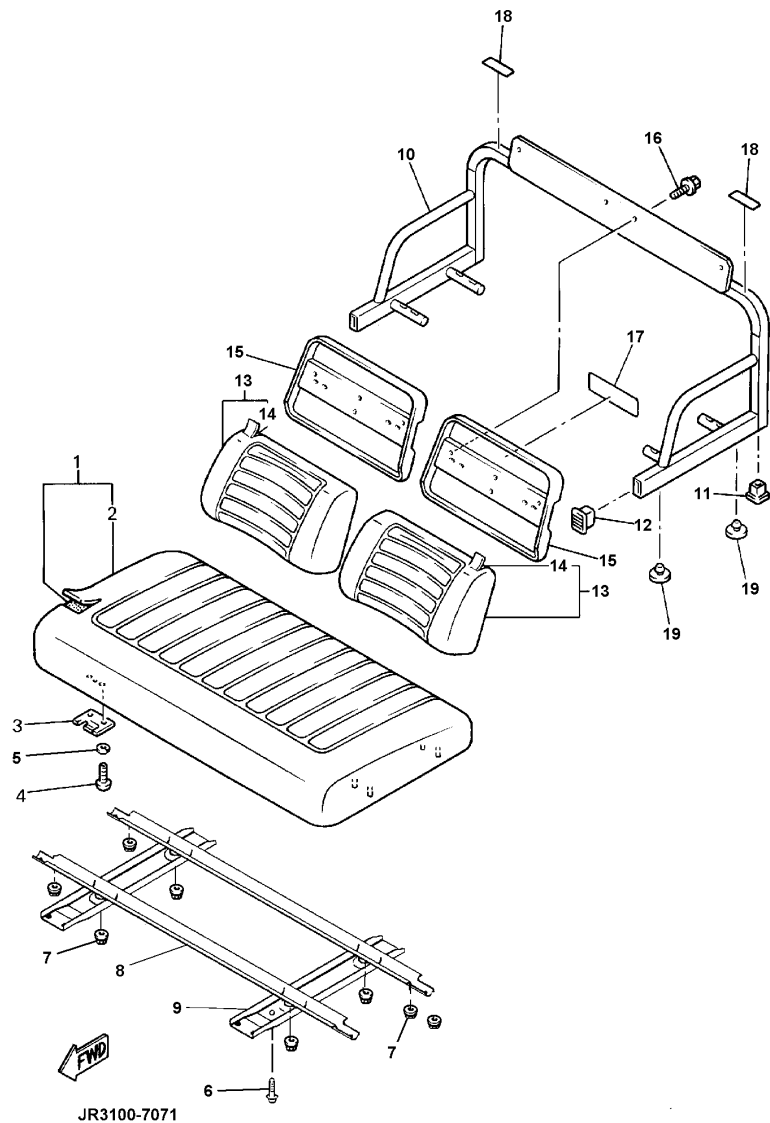

FIG. 31 SEAT

REF NO.	PART NUMBER	DESCRIPTION	QTY	REMARKS
1	JN6-K8401-10-00	CUSHION SEAT	1	UR, F# JR3-300101~
2	JN6-K8404-09-00	.COVER, SEAT	1	
	JN6-K8404-10-00	.COVER, SEAT	1	UR, F# JR3-300101~
3	JN3-K8426-01-00	HINGE, SEAT MALE	2	UR, F# JR3-100500~
4	97095-05012-00	BOLT, HEX	4	F# ~JR3-100499
	90111-06810-00	BOLT, BUTTON	4	F# JR3-100500~
5	92990-05100-00	WASHER, LOCK	4	F# ~JR3-100499
	90204-06870-00	WASHER, LOCK	4	F# JR3-100500~
6	90167-04815-00	SCREW, PAN HEAD	4	
7	90185-08839-00	NUT, SELF-LOCKING	12	
8	JN6-K8121-00-00	REINFORCEMENT 1	2	
9	JN6-K8122-01-00	REINFORCEMENT 2	2	UR, SEE NOTE "A" F# JR3-100500~
10	JJ3-K8420-20-00	SEAT ASSY 2	1	SEE NOTE "B"
11	JJ3-K818E-00-00	CAP, PROTECTOR END 1	2	
12	JJ3-K8139-00-00	CAP, END	2	
13	JR3-K8402-00-00	SEAT SUB ASSY, BACK	2	
14	JR3-K841G-09-00	.COVER, SEAT BACK 2	2	
15	JJ3-K8413-00-00	COVER, SEAT BACK	2	SEE NOTE "C"
16	90119-06915-00	BOLT, WITH WASHER	4	
17	JJ3-K7762-00-00	LABEL, WARNING 2	1	SEE NOTE "C"
18	JJ3-K7763-00-00	LABEL, WARNING 3	2	SEE NOTE "B"
19	JJ3-K8433-00-00	DAMPER, SEAT SUPPORT	4	

NOTE "A": For early units up to and including F# JR3-100499, you must also use REF Numbers 3 (JN3-K8426-01-00, Hinge, Seat Male), 4 (90111-06810-00, Bolt Button) and 5 (90204-06870-00, Washer, Lock).

NOTE "B": When replacing "Seat Assy 2 JJ3-K8420-20-00" you must also replace "Label Warning 3 JJ3-K7763-00-00".

NOTE "C": When replacing the LS "Cover Seat Back JJ3-K8413-00-00" you must also replace "Label Warning 2 JJ3-K7762-00-00".

FIG. 32 STARTER GENERATOR

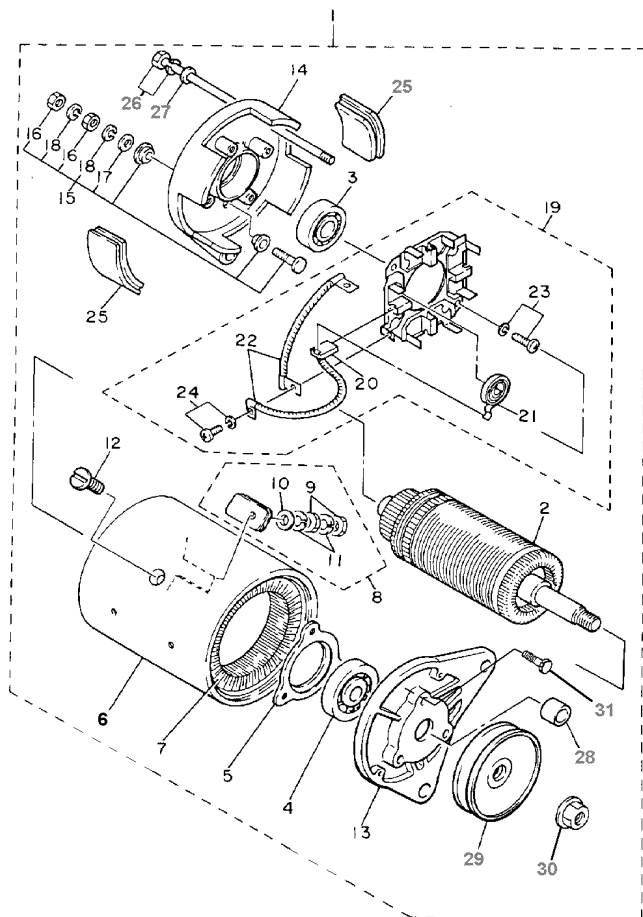

REF NO.	PART NUMBER	DESCRIPTION	QTY	REMARKS
1	JN6-H1100-01-00	STARTER GENERATOR	1	
2	JN3-H1150-00-00	.ARMATURE ASSY	1	
3	93306-20226-00	.BEARING 1 (6202 SD)	1	
4	J10-81158-10-00	.BEARING 2 (6203 SD)	1	
5	J10-81159-10-00	.HOLDER, BEARING	1	
6	JN6-H1110-10-00	.STATOR ASSY	1	
7	JN6-H1160-10-00	.FIELD COIL ASSY	1	
8	J10-81148-10-00	.SCREW 4	2	
9	95380-06600-00	.NUT	4	
10	92990-06600-00	.WASHER, WAVE	2	
11	92995-06100-00	.WASHER, WAVE	4	
12	J10-81146-10-00	.SCREW 2	4	
13	J38-81165-10-00	.BRACKET, STARTER GENERATOR 1	1	
14	J10-81166-10-00	.BRACKET, STARTER GENERATOR 2	1	
15	J10-81147-10-00	.SCREW 3	2	
16	95380-06600-00	.NUT	4	
17	92990-06600-00	.WASHER, WAVE	2	
18	92995-06100-00	.WASHER, WAVE	4	
19	JF2-81119-00-00	.BRUSH HOLDER ASSY	1	
20	JF2-81111-00-00	.BRUSH	4	
21	J38-81113-10-00	.SPRING, BRUSH	4	
22	J10-81115-10-00	.WIRE, LEAD	2	
23	98507-05016-00	.SCREW, PAN HEAD	2	
24	98580-04010-00	.SCREW, PAN HEAD	4	
25	J10-81129-10-00	.COVER, BRUSH	4	
26	J10-81145-10-00	.SCREW 1	2	
27	92990-06600-00	.WASHER, PLAIN	2	

 JN6100-6231

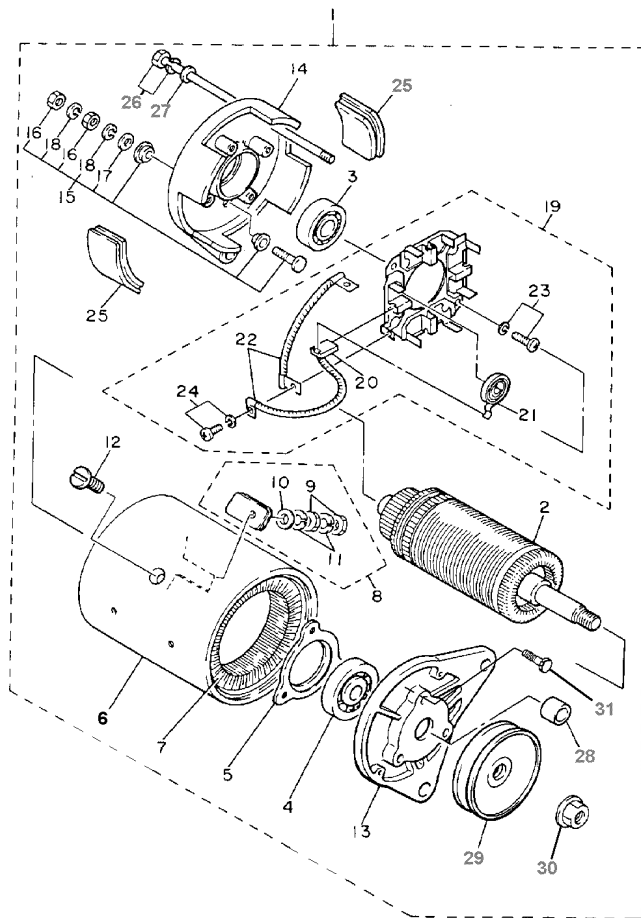
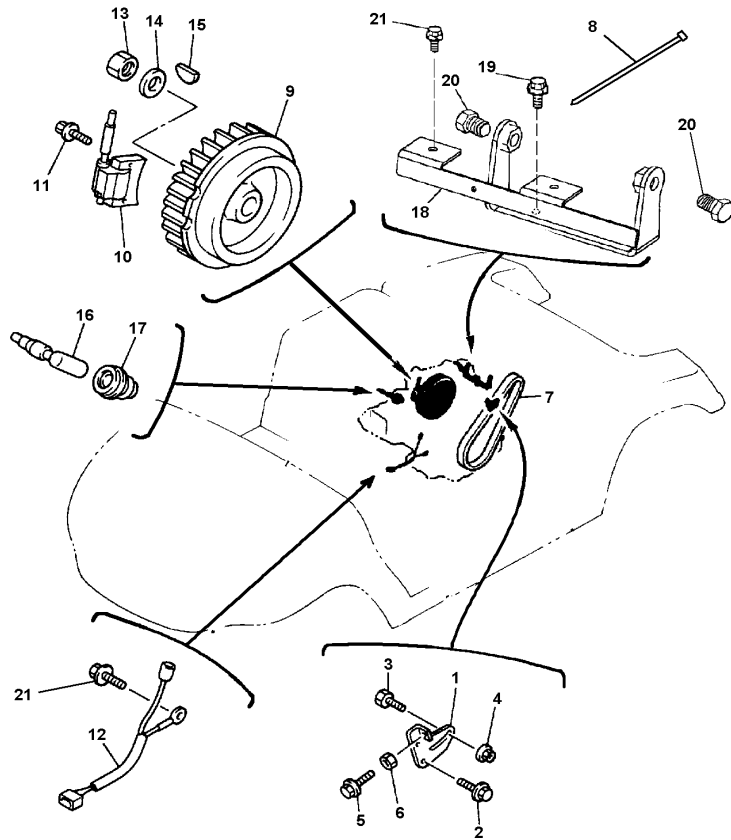

FIG. 32 STARTER GENERATOR

REF NO.	PART NUMBER	DESCRIPTION	QTY	REMARKS
28	JN3-H1661-00-00	.SPACER	1	
29	JN3-H1161-00-00	.PULLEY	2	
30	90179-16889-00	.NUT, FLANGE	1	
31	98507-05018-00	.SCREW	3	



JN6100-6231



FWD
JR3100-7100

FIG. 33 ELECTRICAL 1

REF NO.	PART NUMBER	DESCRIPTION	QTY	REMARKS
1	JN6-H1170-00-00	TENSIONER ASSY.	1	
2	95817-08020-00	BOLT, FLANGE	2	
3	90109-087A5-00	BOLT	1	
4	95707-08500-00	NUT, FLANGE	1	
5	90107-06035-00	BOLT, HEX.	1	
6	95317-06600-00	NUT, HEX.	1	
7	JN6-H1173-00-00	BELT	1	
8	90464-09823-00	CLAMP	1	
9	JN6-85650-00-00	ROTOR ASSY.	1	
10	JN6-85640-00-00	T.C.I. UNIT	1	
11	95817-06025-00	BOLT, FLANGE	2	
12	JN6-82318-00-00	WIRE, SUB-LEAD	1	
13	95307-18600-00	NUT, HEX.	1	
14	90201-18620-00	WASHER, PLAIN	1	
15	90280-04052-00	KEY, WOODRUFF	1	
16	85G-82370-20-00	PLUG CAP ASSY	1	
17	JE8-82372-00-00	SEAL, PLUG CAP	1	
18	JN6-H1171-00-00	BRACKET, STARTER GENERATOR	1	
19	95817-08020-00	BOLT, FLANGE	2	
20	95817-12025-00	BOLT, FLANGE	2	
21	95817-06016-00	BOLT, FLANGE	3	

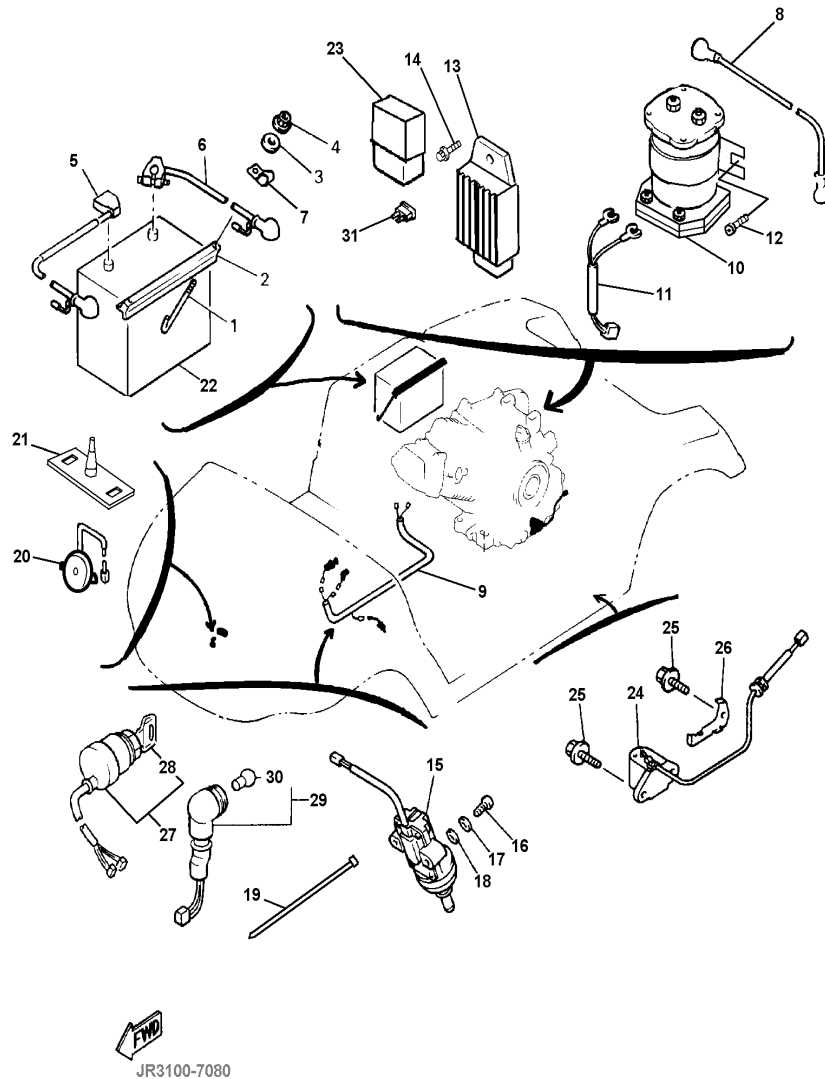
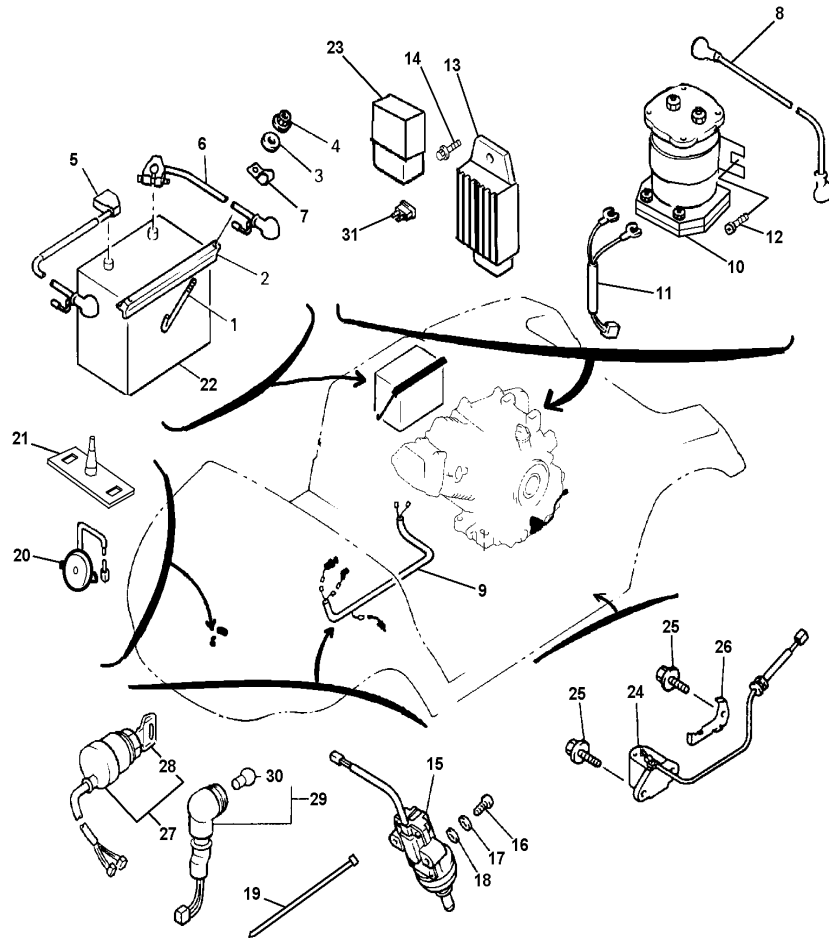

FIG. 34 ELECTRICAL 2

REF NO.	PART NUMBER	DESCRIPTION	QTY	REMARKS
1	JN3-H2133-00-00	SCREW, FITTING	2	
2	J55-H2136-00-00	PLATE, BATTERY	1	
3	92907-06200-00	WASHER, PLAIN	2	
4	95707-06500-00	NUT, FLANGE	2	
5	JR3-H2115-00-00	WIRE, PLUS LEAD	1	
6	JR3-H2116-00-00	WIRE, MINUS LEAD	1	
7	90461-08031-00	CLAMP	2	
8	JR3-H2117-00-00	WIRE, LEAD	1	
9	JR3-H2590-00-00	WIRE HARNESS	1	WITH FUSE
10	JR3-H1950-00-00	RELAY ASSY.	1	
11	JN6-H2105-00-00	HARNESS, WIRE	1	
12	90163-06005-00	SCREW, HEX. T	2	
13	JF2-81910-01-00	VOLTAGE REGULATOR	1	
14	95817-06016-00	BOLT, FLANGE	1	
15	JF7-82817-20-00	SWITCH, ACCELERATOR STOP	1	
16	98507-05025-00	SCREW, PAN HEAD	2	
17	92907-05100-00	WASHER, LOCK	2	
18	92907-05600-00	WASHER, PLATE	2	
19	90464-31827-00	CLAMP	6	
20	JR1-H3383-01-00	BUZZER	1	
21	JN6-H3386-00-00	STAY, BUZZER	1	
22	*	BATTERY ASSY.	1	LM
23	4U8-81950-02-00	RELAY ASSY.	1	
24	JN6-85720-12-00	OIL LEVEL GAUGE	1	
25	95817-06012-00	BOLT, FLANGE	4	
26	JN6-85724-00-00	CLAMP, OIL LEVEL	1	
27	JN8-82510-01-00	MAIN SWITCH	1	

FIG. 34 ELECTRICAL 2



REF NO.	PART NUMBER	DESCRIPTION	QTY	REMARKS
28	J44-82511-00-YY	.KEY, MAIN SWITCH	1	
29	JN6-83530-00-00	PILOT LAMP A	1	
30	123-83516-21-XX	.BULB, (12V-3.4W)	1	
31	42X-82151-00-00	FUSE (10A-BLADE)	1	

JR3100-7080